

MEMOBUS Ethernet Driver

1	System Configuration.....	3
2	Selection of External Device	5
3	Example of Communication Setting.....	6
4	Setup Items.....	26
5	Supported Device.....	30
6	Device Code and Address Code.....	32
7	Error Messages.....	33

Introduction

This manual describes how to connect the Display (GP3000 series) and the External Device (target PLC).

In this manual, the connection procedure will be described by following the below sections:

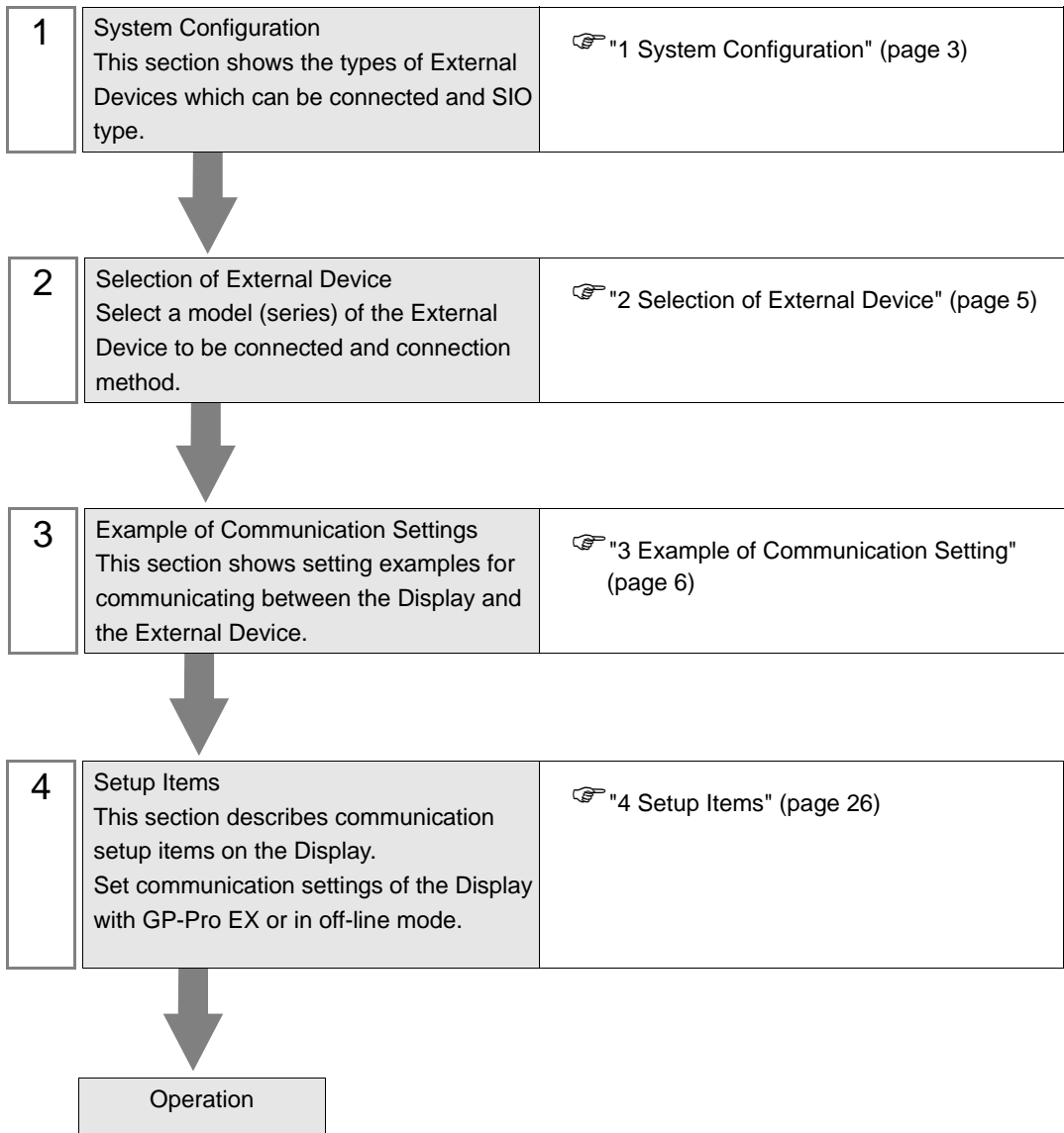

1 System Configuration

The system configuration in the case when the External Device of YASUKAWA Electric Corporation and the Display are connected is shown.

Series	CPU	Link I/F	Interface	Setting Example
MP900	MP920	Ethernet port on 218IF-01 (10BASE-5)	Ethernet (TCP)	Setting Example 1 (page 6)
			Ethernet (UDP)	Setting Example 2 (page 11)
MP2000	MP2300 MP2200	Ethernet port on 218IF-01	Ethernet (TCP)	Setting Example 3 (page 16)
			Ethernet (UDP)	Setting Example 4 (page 21)

■ Connection Configuration

- 1:1 Connection

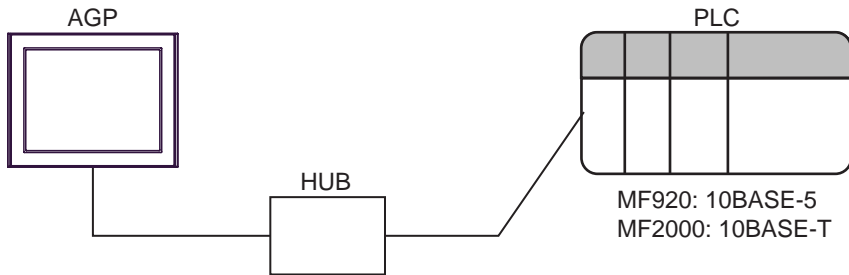

- 1:n Connection

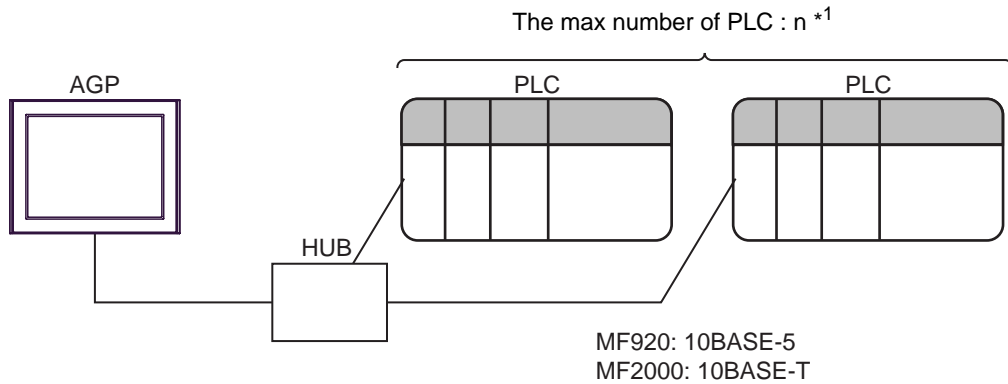

*1 The maximum 32 PLCs connection by UDP connection, the maximum 16 PLCs connection by TCP connection.

- n:1 Connection

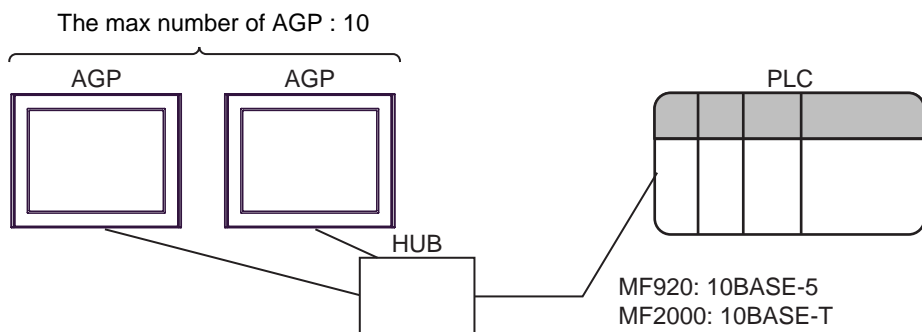

2 Selection of External Device

Select the External Device to be connected to the Display.

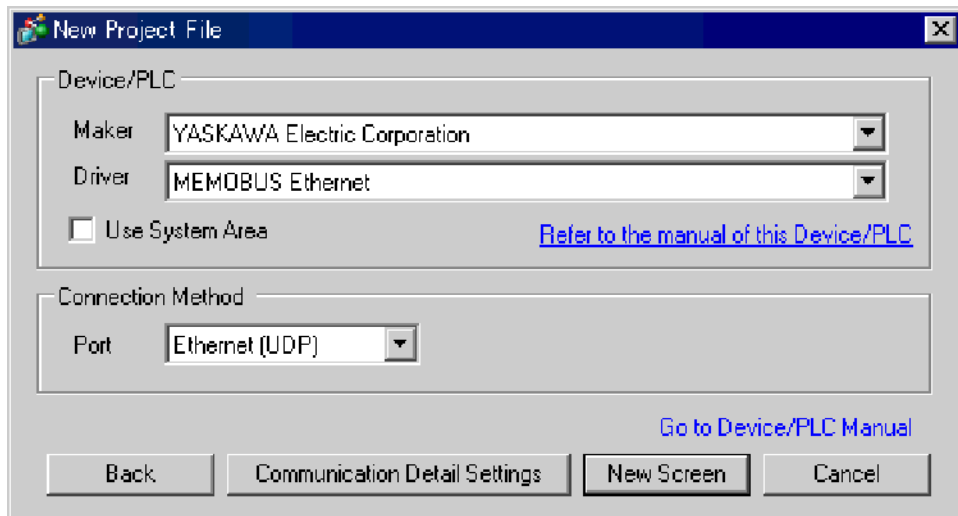

Setup Items	Setup Description
Maker	Select the maker of the External Device to be connected. Select "YASUKAWA Electric Corporation".
Driver	Select a model (series) of the External Device to be connected and connection method. Select "MEMOBUS Ethernet". Check the External Device which can be connected in "MEMOBUS Ethernet" in system configuration. ☞ "1 System Configuration" (page 3)
Use System Area	Check this option when you synchronize the system data area of Display and the device (memory) of External Device. When synchronized, you can use the ladder program of External Device to switch the display or display the window on the display. Cf. GP-Pro EX Reference Manual "Appendix 1.4 LS Area (only for direct access method)" This can be also set with GP-Pro EX or in off-line mode of Display. Cf. GP-Pro EX Reference Manual " 6.13.6 Setting Guide of [System Setting Window]■[Main Unit Settings] Settings Guide◆System Area Setting" Cf. GP3000 Series User Manual "4.3.6 System Area Setting"
Port	Select the Display port to be connected to the External Device.

3 Example of Communication Setting

Examples of communication settings of the Display and the External Device, recommended by Pro-face, are shown.

3.1 Setting Example 1

■ Settings of GP-Pro EX

◆ Communication Settings

To display the setting screen, select [Device/PLC Settings] from [System setting window] in workspace.

Device/PLC 1

Summary [Change Device/PLC](#)

Maker Driver Port

Text Data Mode [Change](#)

Communication Settings

Port No. Auto

Timeout (sec)

Retry

Wait To Send (ms)

Device-Specific Settings

Allowable No. of Device/PLCs 16 Unit(s)

No.	Device Name	Settings
1	PLC1	IP Address=192.168.001.001, Port No.=1024, Data Code=BINARY

◆ Device Setting

To display the setting screen, click  ([Setting]) of External Device you want to set from [Device-Specific Settings] of [Device/PLC Settings].

When you connect multiple External Device, click  from [Device-Specific Settings] of [Device/PLC Settings] to add another External Device.

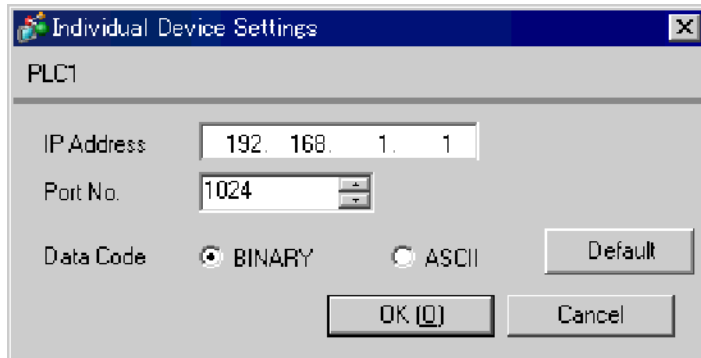

◆ Notes

- Check with a network administrator about IP address. Do not set the duplicate IP address.
- Set IP address on the External Device for IP address in Device-specific settings.
- You need to set IP address on the display in the off-line mode of the display.

■ Settings of External Device

Communication setting of communication module 218IF by ladder software. (Check the operation in MPE720 Version5.32)

◆ Ladder Software Setting

1 Start ladder software, make an order folder and a PLC folder in a root folder.

Select the connected PLC at the time of PLC folder making.

2 Click the right button of the PLC which select logon in the displayed menu.

NOTE

- Logon after confirming that a check does not begin [online] of a displayed menu.
- Refer to User's Manual of the PLC about a method of logon.

3 Double-click the [Definition folder]-[Module constitution] of the PLC folder, and display [Engineering Manager].

4 Select the rack classification and link I/F, the pull-down menu in [Controller] of [Engineering Manager].

Set the number corresponding to the slot number that a communication module uses.

Select the communication module, setting contents are displayed to [Module details] of [Engineering Manager].

5 Double-click the number part at No. in [Module details].

Double-click the slot number connecting the ethernet unit.

Setup Items		Setup Description
Transmission parameter	This Station IP address	PLC IP address
Connection parameter	My Port	PLC port No.
	DST. IP Address ^{*1}	GP-Pro EX IP address
	DST. Port ^{*1}	GP-Pro EX port No.
	Connection type	TCP
	Protocol type	expansion memobus
	Code	BIN

*1 When check the [Auto] of a port number by communication setting of the GP-ProEX, the IP address set "0.0.0.0" and the port number set "00000".

6 Double-click the "No.00", and set serial communication.

Use serial communication setting to forward communication setting and the ladder program to the PLC.

7 Save setting content and finish [Engineering Manager].

8 Make the communication ladder "high speed drawing".

 ◆ Ladder Program for Communication" (page 9)

9 DIP switch "INIT" of a communication module is ON and spend a power supply.

10 Forward communication setting and a ladder program to a communication module.

11 Logon the PLC at online and write in the data which transferred at flash memory.

12 Power supply of PLC is OFF and DIP switch of the INIT is OFF, after spend the power supply of PLC.

◆ Notes

- Check with a network administrator about IP address. Do not set the duplicate IP address.
- Please refer to the manual of the ladder software for more detail.

◆ Ladder Program for Communication

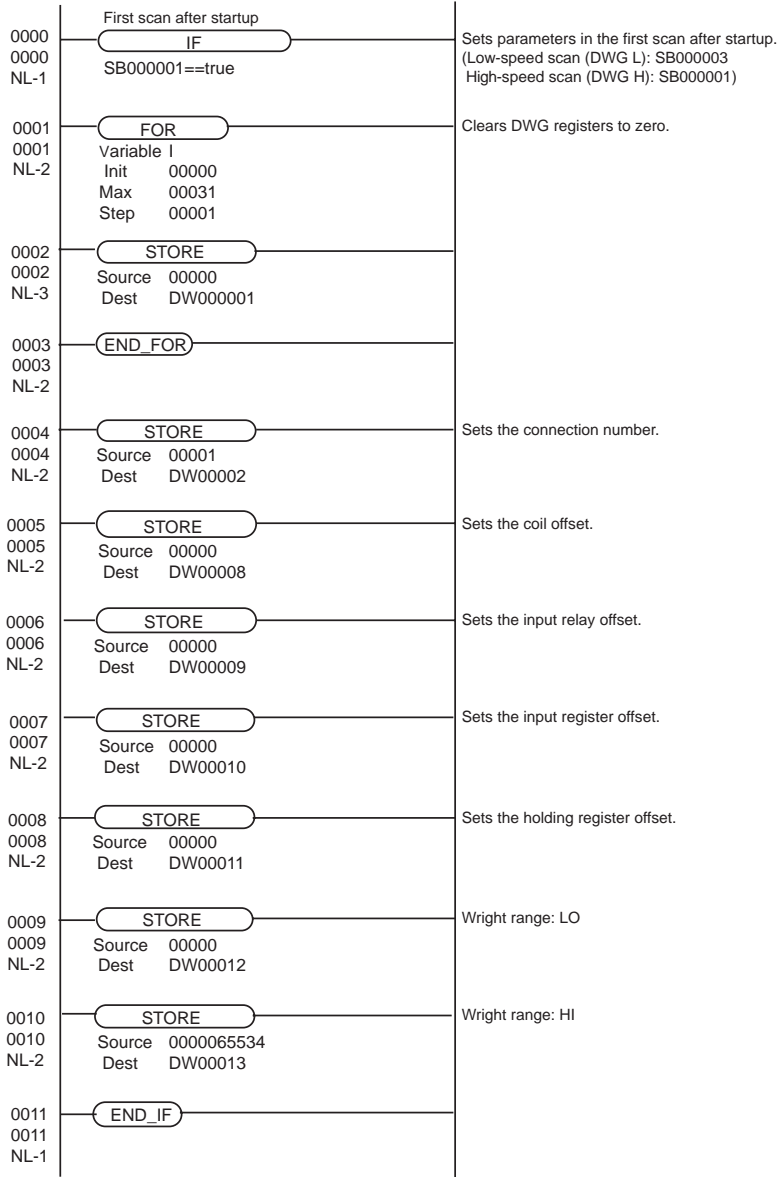

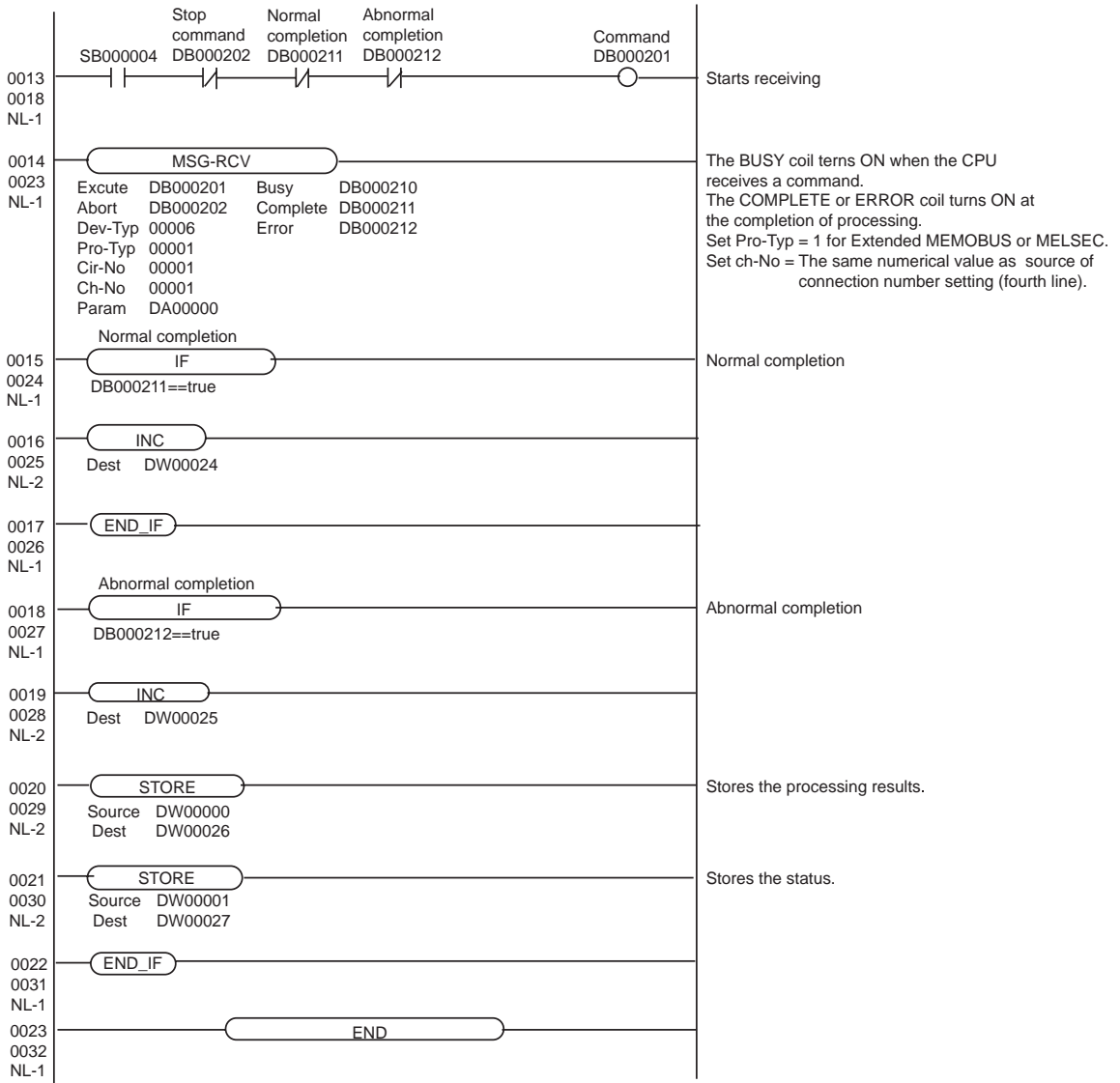

3.2 Setting Example 2

■ Settings of GP-Pro EX

◆ Communication Settings

To display the setting screen, select [Device/PLC Settings] from [System setting window] in workspace.

The screenshot shows the 'Device/PLC 1' settings window. It is divided into several sections:

- Summary:** Contains fields for 'Maker' (YASKAWA Electric Corporation), 'Driver' (MEMOBUS Ethernet), and 'Port' (Ethernet (UDP)). A 'Change Device/PLC' link is visible in the top right.
- Text Data Mode:** A dropdown menu is set to '1' with a 'Change' link next to it.
- Communication Settings:** Includes dropdown menus for 'Port No.' (1024), 'Timeout' (3 sec), 'Retry' (2), and 'Wait To Send' (0 ms). A 'Default' button is located to the right of the 'Wait To Send' field.
- Device-Specific Settings:** Shows 'Allowable No. of Device/PLCs' as 32 Unit(s) with a plus icon. Below is a table with columns 'No.', 'Device Name', and 'Settings'.

No.	Device Name	Settings
1	PLC1	IP Address=192.168.001.001,Port No.=1024,Data Code=BINARY

◆ Device Setting

To display the setting screen, click  ([Setting]) of External Device you want to set from [Device-Specific Settings] of [Device/PLC Settings].

When you connect multiple External Device, click  from [Device-Specific Settings] of [Device/PLC Settings] to add another External Device.

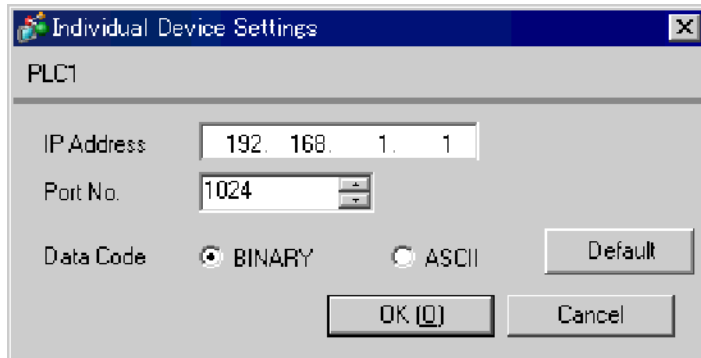

◆ Notes

- Check with a network administrator about IP address. Do not set the duplicate IP address.
- Set IP address on the External Device for IP address in Device-specific settings.
- You need to set IP address on the display in the off-line mode of the display.

■ Settings of External Device

◆ Ladder Software Setting

- 1 Start ladder software, make an order folder and a PLC folder in a root folder.
Select the connected PLC at the time of PLC folder making.
- 2 Click the right button of the PLC which select logon in the displayed menu.

NOTE

- Logon after confirming that a check does not begin [online] of a displayed menu.
- Refer to User's Manual of the PLC about a method of logon.

- 3 Double-click the [Definition folder]-[Module constitution] of the PLC folder, and display [Engineering Manager].
- 4 Select the rack classification and link I/F, the pull-down menu in [Controller] of [Engineering Manager].
Set the number corresponding to the slot number that a communication module uses.
Select the communication module, setting contents are displayed to [Module details] of [Engineering Manager].
- 5 Double-click the number part at No. in [Module details].
Double-click the slot number connecting the ethernet unit.

Setup Items		Setup Description
Transmission parameter	This Station IP address	PLC IP address
Connection parameter	My Port	PLC port No.
	DST. IP Address	GP-Pro EX IP address
	DST. Port	GP-Pro EX port No.
	Connection type	UDP
	Protocol type	expansion memobus
	Code	BIN

- 6 Double-click the "No.00", and set serial communication.
Use serial communication setting to forward communication setting and the ladder program to the PLC.
- 7 Save setting content and finish [Engineering Manager].
- 8 Make the communication ladder "high speed drawing".
☞ "◆ Ladder Program for Communication" (page 14)
- 9 DIP switch "INIT" of a communication module is ON and spend a power supply.
- 10 Forward communication setting and a ladder program to a communication module.
- 11 Logon the PLC at online and write in the data which transferred at flash memory.
- 12 Power supply of PLC is OFF and DIP switch of the INIT is OFF, after spend the power supply of PLC.

◆ Notes

- Check with a network administrator about IP address. Do not set the duplicate IP address.
- Please refer to the manual of the ladder software for more detail.

◆ Ladder Program for Communication

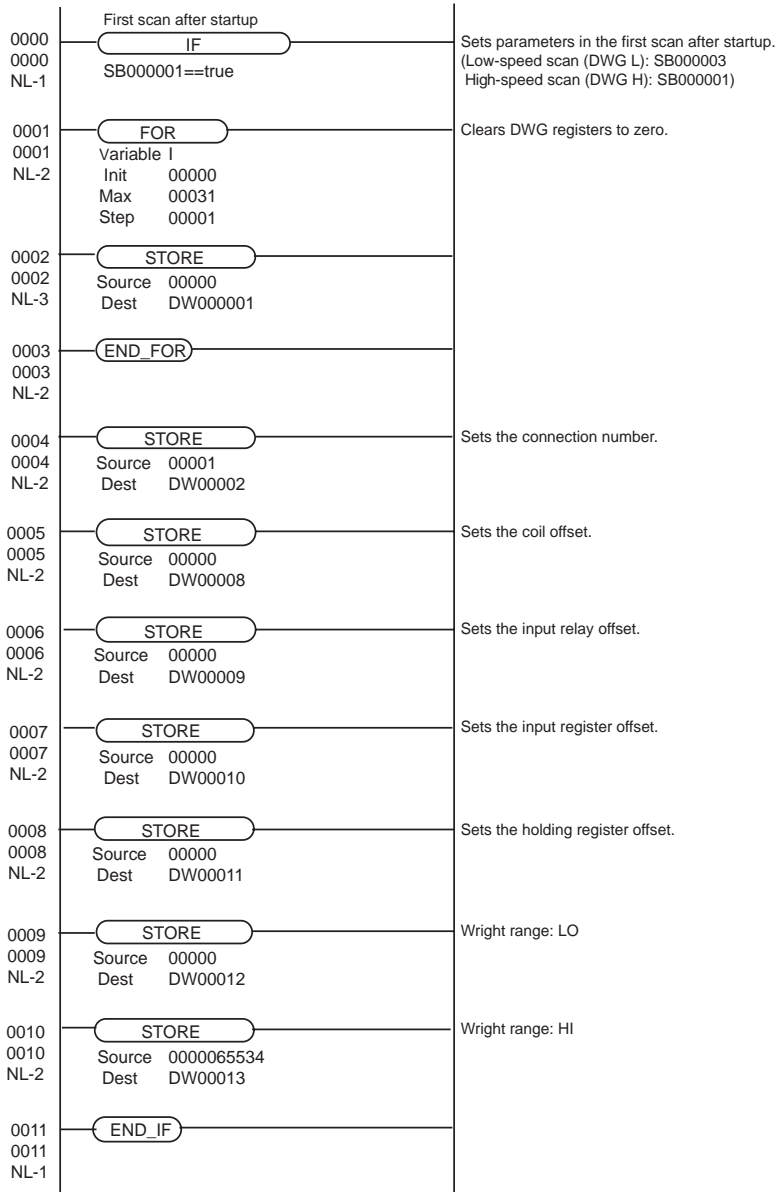

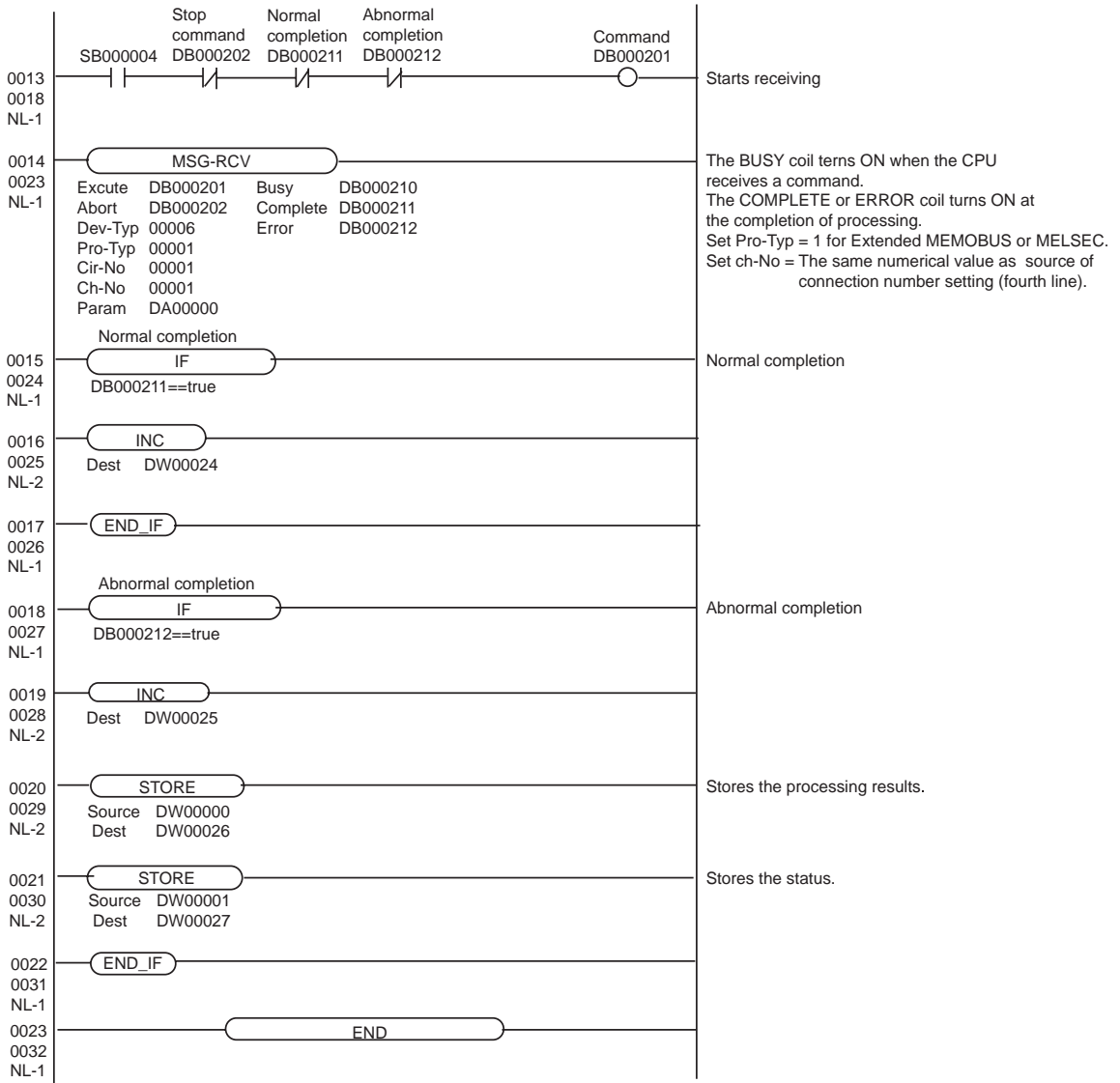

3.3 Setting Example 3

■ Settings of GP-Pro EX

◆ Communication Settings

To display the setting screen, select [Device/PLC Settings] from [System setting window] in workspace.

The screenshot shows the 'Device/PLC 1' settings window. It is divided into three main sections: Summary, Communication Settings, and Device-Specific Settings.

- Summary:** Contains fields for 'Maker' (YASKAWA Electric Corporation), 'Driver' (MEMOBUS Ethernet), and 'Port' (Ethernet (TCP)). A 'Change Device/PLC' link is visible in the top right.
- Text Data Mode:** A dropdown menu is set to '1' with a 'Change' button next to it.
- Communication Settings:** Includes 'Port No.' (1024) with an 'Auto' checkbox, 'Timeout' (3 sec), 'Retry' (0), and 'Wait To Send' (0 ms). A 'Default' button is located to the right of the 'Wait To Send' field.
- Device-Specific Settings:** Shows 'Allowable No. of Device/PLCs' as 16 Unit(s). Below this is a table with columns for 'No.', 'Device Name', and 'Settings'.

No.	Device Name	Settings
1	PLC1	IP Address=192.168.001.001,Port No.=1024,Data Code=BINARY

◆ Device Setting

To display the setting screen, click  ([Setting]) of External Device you want to set from [Device-Specific Settings] of [Device/PLC Settings].

When you connect multiple External Device, click  from [Device-Specific Settings] of [Device/PLC Settings] to add another External Device.

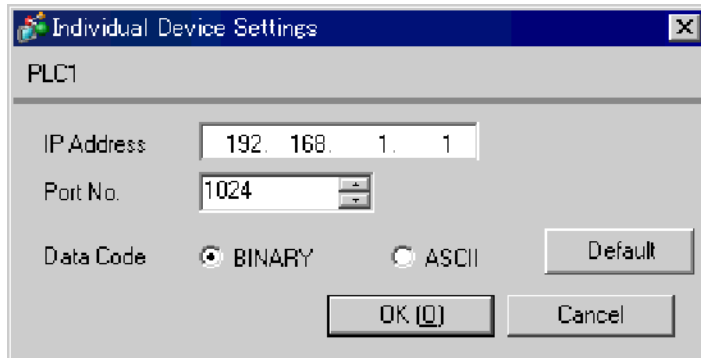

◆ Notes

- Check with a network administrator about IP address. Do not set the duplicate IP address.
- Set IP address on the External Device for IP address in Device-specific settings.
- You need to set IP address on the display in the off-line mode of the display.

■ Settings of External Device

◆ Ladder Software Setting

1 Start ladder software, make an order folder and a PLC folder in a root folder.

Select the connected PLC at the time of PLC folder making.

2 Click the right button of the PLC which select logon in the displayed menu.

NOTE

- Logon after confirming that a check does not begin [online] of a displayed menu.
- Refer to User's Manual of the PLC about a method of logon.

3 Double-click the [Definition folder]-[Module constitution] of the PLC folder, and display [Engineering Manager].

4 Select the rack classification and link I/F, the pull-down menu in [Controller] of [Engineering Manager].

Set the number corresponding to the slot number that a communication module uses.

Select the communication module, setting contents are displayed to [Module details] of [Engineering Manager].

5 Double-click the number part at No. in [Module details].

Double-click the slot number connecting the ethernet unit.

Setup Items		Setup Description
Transmission parameter	This Station IP address	PLC IP address
	My Port	PLC port No.
Connection parameter	DST. IP Address ^{*1}	GP-Pro EX IP address
	DST. Port ^{*1}	GP-Pro EX port No.
	Connection type	TCP
	Protocol type	expansion memobus
	Code	BIN

*1 When check the [Auto] of a port number by communication setting of the GP-ProEX, the IP address set "0.0.0.0" and the port number set "00000".

6 Double-click the "No.1", and set serial communication.

Use serial communication setting to forward communication setting and the ladder program to the PLC.

7 Save setting content and finish [Engineering Manager].

8 Make the communication ladder "high speed drawing".

 ◆ Ladder Program for Communication" (page 19)

9 DIP switch "INIT" of a communication module is ON and spend a power supply.

10 Forward communication setting and a ladder program to a communication module.

11 Logon the PLC at online and write in the data which transferred at flash memory.

12 Power supply of PLC is OFF and DIP switch of the INIT is OFF, after spend the power supply of PLC.

◆ Notes

- Check with a network administrator about IP address. Do not set the duplicate IP address.
- Please refer to the manual of the ladder software for more detail.

◆ Ladder Program for Communication

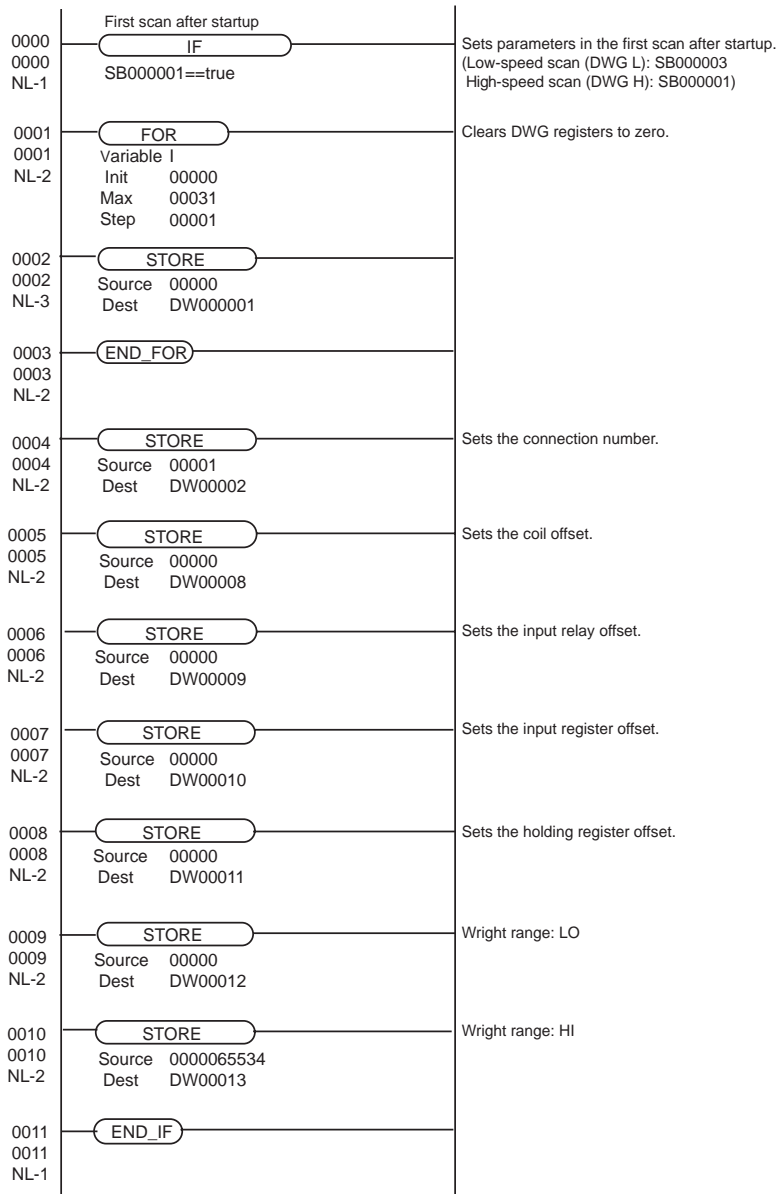

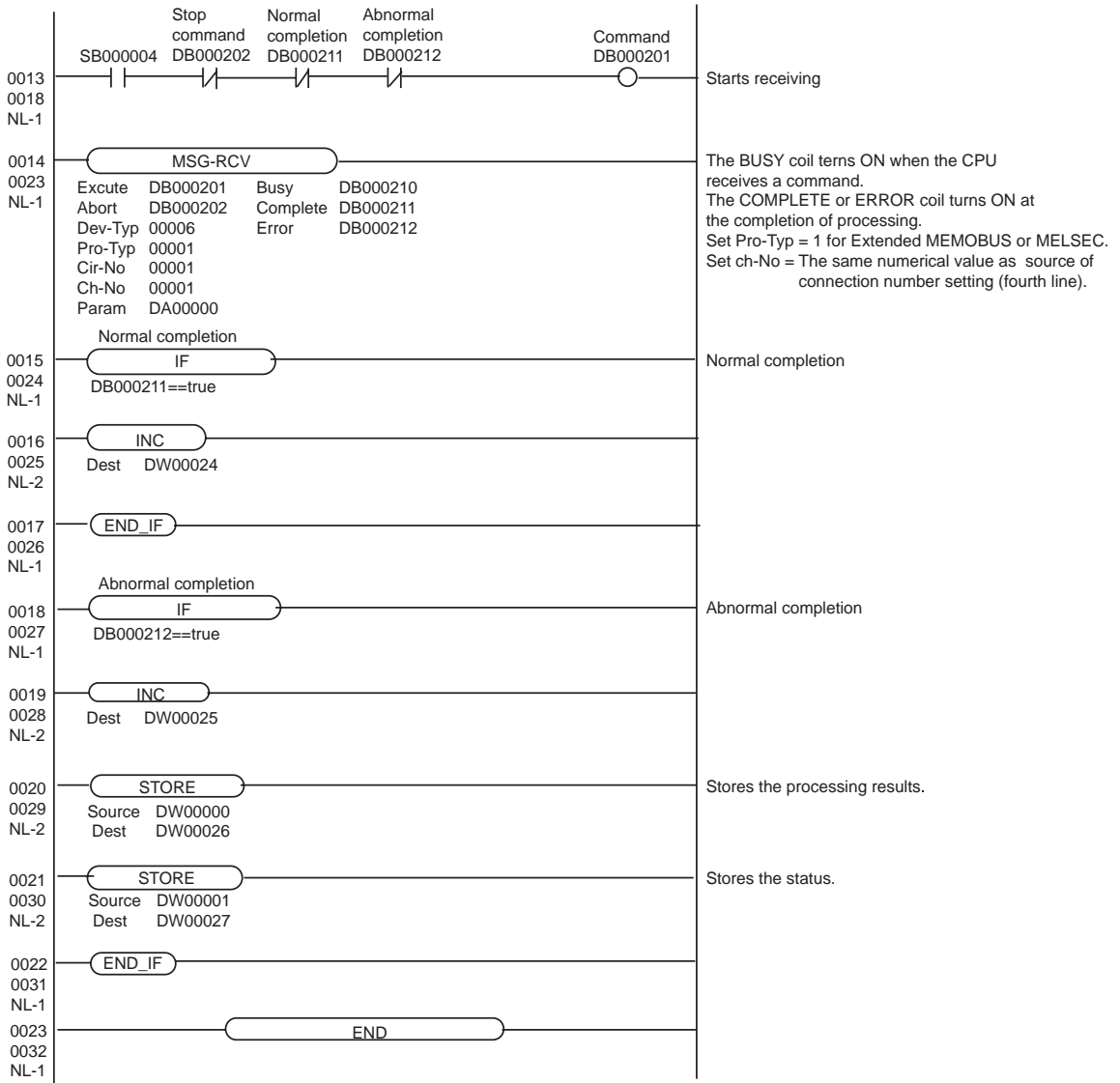

3.4 Setting Example 4

■ Settings of GP-Pro EX

◆ Communication Settings

To display the setting screen, select [Device/PLC Settings] from [System setting window] in workspace.

The screenshot shows the 'Device/PLC 1' settings window. It is divided into three main sections:

- Summary:** Contains fields for 'Maker' (YASKAWA Electric Corporation), 'Driver' (MEMOBUS Ethernet), and 'Port' (Ethernet (UDP)). There is a 'Change Device/PLC' link in the top right.
- Text Data Mode:** A dropdown menu set to '1' with a 'Change' link.
- Communication Settings:** Includes dropdown menus for 'Port No.' (1024), 'Timeout' (3 sec), 'Retry' (2), and 'Wait To Send' (0 ms). A 'Default' button is located to the right of the 'Wait To Send' field.
- Device-Specific Settings:** Shows 'Allowable No. of Device/PLCs' as 32 Unit(s) with a plus icon. Below is a table with columns 'No.', 'Device Name', and 'Settings'.

No.	Device Name	Settings
1	PLC1	IP Address=192.168.001.001,Port No.=1024,Data Code=BINARY

◆ Device Setting

To display the setting screen, click  ([Setting]) of External Device you want to set from [Device-Specific Settings] of [Device/PLC Settings].

When you connect multiple External Device, click  from [Device-Specific Settings] of [Device/PLC Settings] to add another External Device.

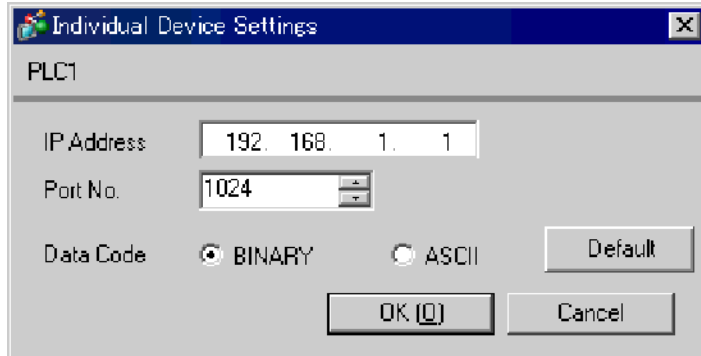

◆ Notes

- Check with a network administrator about IP address. Do not set the duplicate IP address.
- Set IP address on the External Device for IP address in Device-specific settings.
- You need to set IP address on the display in the off-line mode of the display.

■ Settings of External Device

◆ Ladder Software Setting

- 1 Start ladder software, make an order folder and a PLC folder in a root folder.
Select the connected PLC at the time of PLC folder making.
- 2 Click the right button of the PLC which select logon in the displayed menu.

NOTE

- Logon after confirming that a check does not begin [online] of a displayed menu.
- Refer to User's Manual of the PLC about a method of logon.

- 3 Double-click the [Definition folder]-[Module constitution] of the PLC folder, and display [Engineering Manager].
- 4 Select the rack classification and link I/F, the pull-down menu in [Controller] of [Engineering Manager].
Set the number corresponding to the slot number that a communication module uses.
Select the communication module, setting contents are displayed to [Module details] of [Engineering Manager].
- 5 Double-click the number part at No. in [Module details].
Double-click the slot number connecting the ethernet unit.

Setup Items		Setup Description
Transmission parameter	This Station IP address	PLC IP address
Connection parameter	My Port	PLC port No.
	DST. IP Address	GP-Pro EX IP address
	DST. Port	GP-Pro EX port No.
	Connection type	UDP
	Protocol type	expansion memobus
	Code	BIN

- 6 Double-click the "No.1", and set serial communication.
Use serial communication setting to forward communication setting and the ladder program to the PLC.
- 7 Save setting content and finish [Engineering Manager].
- 8 Make the communication ladder "high speed drawing".
☞ "◆ Ladder Program for Communication" (page 24)
- 9 DIP switch "INIT" of a communication module is ON and spend a power supply.
- 10 Forward communication setting and a ladder program to a communication module.
- 11 Logon the PLC at online and write in the data which transferred at flash memory.
- 12 Power supply of PLC is OFF and DIP switch of the INIT is OFF, after spend the power supply of PLC.

◆ Notes

- Check with a network administrator about IP address. Do not set the duplicate IP address.
- Please refer to the manual of the ladder software for more detail.

◆ Ladder Program for Communication

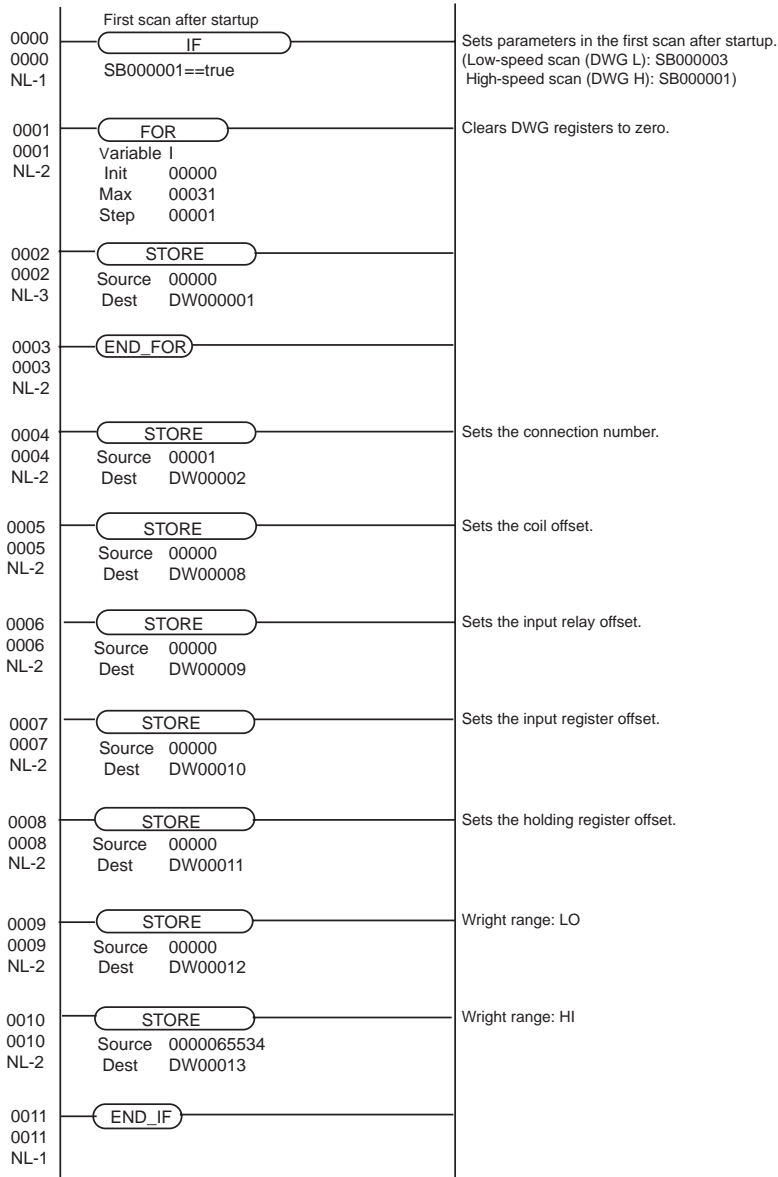

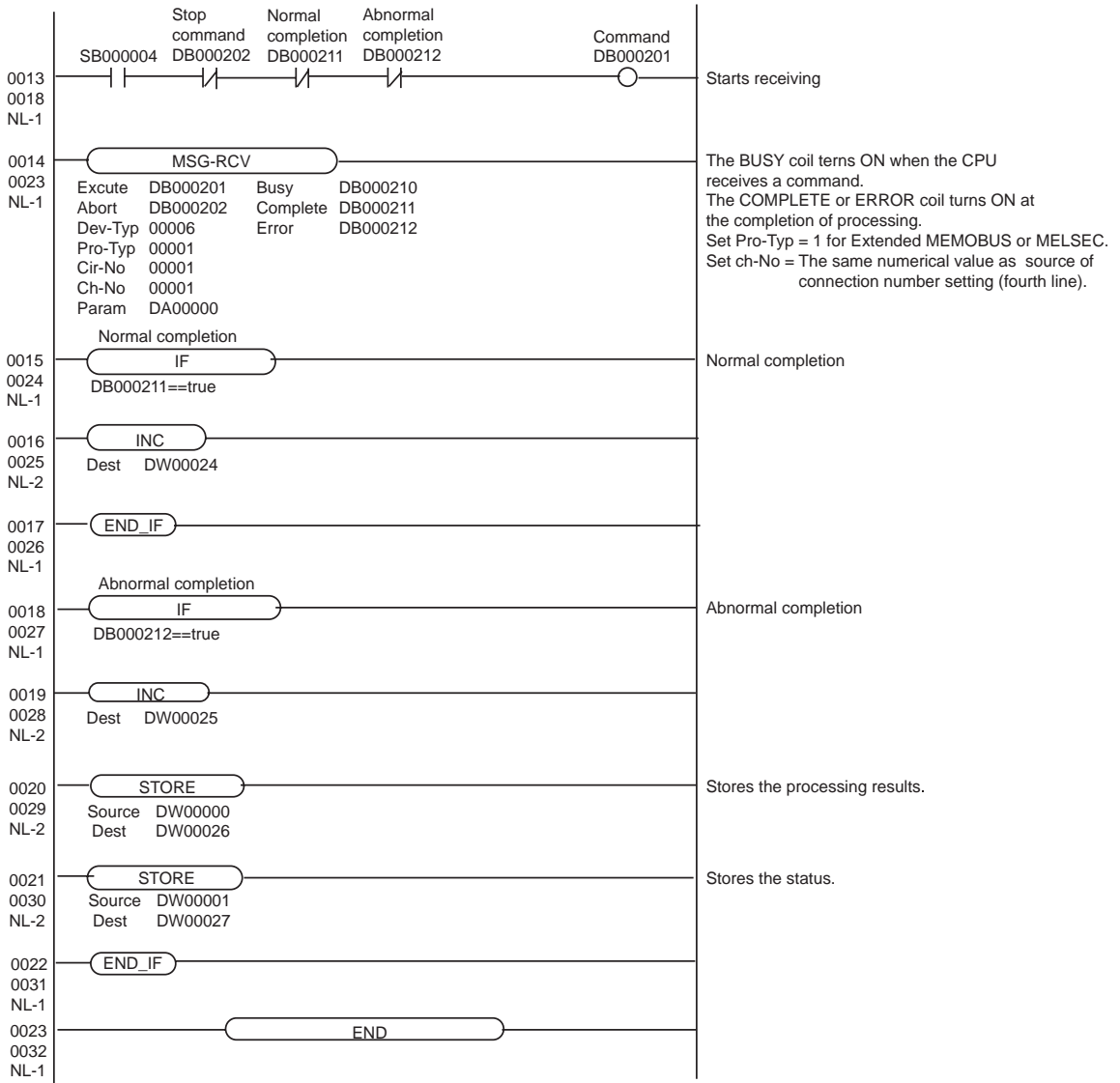

4 Setup Items

Set communication settings of the Display with GP-Pro EX or in off-line mode of the Display.

The setting of each parameter must be identical to that of External Device.

☞ "3 Example of Communication Setting" (page 6)

4.1 Setup Items in GP-Pro EX

■ Communication Settings

To display the setting screen, select [Device/PLC Settings] from [System setting window] in workspace.

Setup Items	Setup Description
Port No.	Enter a port number of the External Device, using 1024 to 65535. Check into [Auto], and a port number is set automatically. NOTE Set the [Auto], when select the [Ethernet (TCP)] in [Connection Method] only.
Timeout	Use an integer from 1 to 127 to enter the time (s) for which Display waits for the response from External Device.
Retry	In case of no response from the External Device, use an integer from 0 to 255 to enter how many times the Display retransmits the command.
Wait To Send	Use an integer from 0 to 255 to enter standby time (ms) for the Display from receiving packets to transmitting next commands.

◆ Device Setting

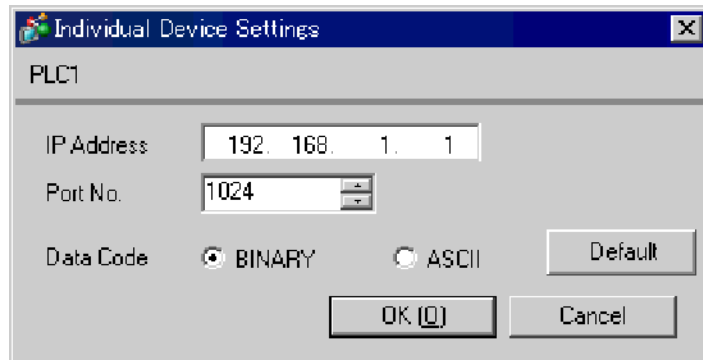

Setup Items	Setup Description
IP Address	Set IP address of the External Device. NOTE <ul style="list-style-type: none"> Check with a network administrator about IP address. Do not set the duplicate IP address.
Port No.	Enter a port number of the External Device, using 256 to 65534.
Data Code	Select the data format in communication with the PLC.

4.2 Setup Items in Off-Line Mode

NOTE • Please refer to GP3000 Series User Manual for more information on how to enter off-line mode or about operation.

Cf. GP3000 Series User Manual "Chapter 4 Settings"

◆ Communication Settings

To display the setting screen, touch [Device/PLC Settings] from [Peripheral Settings] in off-line mode. Touch the External Device you want to set from the displayed list.

Comm.	Device			
MEMOBUS Ethernet			[TCP]	Page 1/1
Port No.	<input type="radio"/> Fixed <input checked="" type="radio"/> Auto	1024	▼	▲
Timeout(s)		3	▼	▲
Retry		0	▼	▲
Wait To Send(ms)		0	▼	▲
	Exit		Back	2006/01/31 15:42:04

Setup Items	Setup Description
Port No.	Enter a port number of the GP-Pro EX. The port number that input is assigned without being concerned with select of "Fixed" "Auto" by UDP connection. Select either of "Fixed" "Auto" by TCP connection. Enter a port number of the GP-Pro EX with "1024-65535", when select "Fixed". Assign automatically without affecting the input value, when select "Auto".
Timeout	Use an integer from 1 to 127 to enter the time (s) for which Display waits for the response from External Device.
Retry	In case of no response from the External Device, use an integer from 0 to 255 to enter how many times the Display retransmits the command.
Wait To Send	Use an integer from 0 to 255 to enter standby time (ms) for the Display from receiving packets to transmitting next commands.

◆ Device Setting

To display the setting screen, touch [Device/PLC Settings] from [Peripheral Settings]. Touch the External Device you want to set from the displayed list, and touch [Device].

Comm.	Device			
MEMOBUS Ethernet		[TCP]	Page 1/1	
Device/PLC Name	PLC1 ▼			
IP Address	192	168	1	1
Port No.				1024 ▼ ▲
Data Code	<input checked="" type="radio"/> BINARY <input type="radio"/> ASCII			
Exit		Back		2006/01/31 15:42:07

Setup Items	Setup Description
Device/PLC Name	Select the External Device for device setting. Device name is a title of External Device set with GP-Pro EX.(Initial value [PLC1])
IP Address	Set IP address of the External Device. <div style="border: 1px solid black; padding: 2px; display: inline-block;">NOTE</div> <ul style="list-style-type: none"> Check with a network administrator about IP address. Do not set the duplicate IP address.
Port No.	Enter a port number of the External Device, using 256 to 65534.
Data Code	Select the data format in communication with the PLC.

5 Supported Device

Range of supported device address is shown in the table below. Please note that the actually supported range of the devices varies depending on the External Device to be used. Please check the actual range in the manual of your External Device.

 This address can be specified as system data area.

Device	Bit address	Word address	32 bits	Remarks
Coil	GMB00000 - GMB4095F	GMB0000 - GMB4095	L / H	
Input Relay	GIB00000 - GIB0FFFF	GIB0000 - GIB0FFF		*1
Input Register	-----	GIW0000 - GIW7FFF		Bit F *1
Holding Register	-----	GMW00000 - GMW65534		Bit F

*1 Write disable

The address of GP becomes the address which added an offset to the real address of the PLC.

Address relations of GP and PLC are as follows.

Device	Display on GP-Pro EX	Display on PLC
Coil (Bit device)	GMB00000 - GMB4095F	MB00000+Offset - MB4095F+Offset
Coil (Word device)	GMB0000 - GMB4095	MB0000+Offset - MB4095+Offset
Input Relay (Bit device)	GIB00000 - GIB0FFFF	IB00000+Offset - IB0FFFF+Offset
Input Relay (Word device)	GIB0000 - GIB0FFF	IB0000+Offset - IB0FFF+Offset
Input Register	GIW0000 - GIW7FFF	IW0000+Offset - IW7FFF+Offset
Holding Register	GMW00000 - GMW65534	MW00000+Offset - MW65534+Offset

e.g) When you specify "GMW00000" in GP-Pro EX, the address of "MW00000" to which offset value is added, is specified as the actual address in the External Device. Offset value is described as "Head REG" in the ladder software.

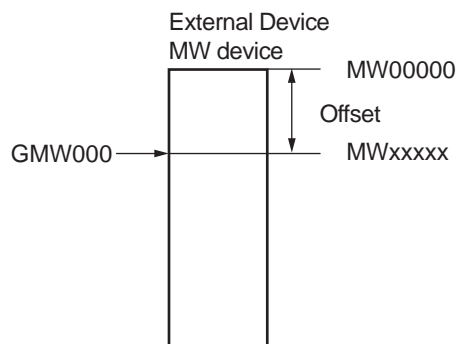

NOTE

- Please refer to the GP-Pro EX Reference Manual for system data area.
Cf. GP-Pro EX Reference Manual "Appendix 1.4 LS Area (only for direct access method)"
- Please refer to the precautions on manual notation for icons in the table.
 "Manual Symbols and Terminology"

6 Device Code and Address Code

Use device code and address code when you select "Device Type & Address" for the address type in data displays.

Device	Device Name	Device Code (HEX)	Address Code
Coil	GMB	0080	Word Address
Input Relay	GIB	0081	Word Address
Input Register	GIW	0001	Word Address
Holding Register	GMW	0000	Word Address

7 Error Messages

Error messages are displayed on the screen of Display as follows: "No. : Device Name: Error Message (Error Occurrence Area)". Each description is shown below.

Item	Description
No.	Error No.
Device Name	Name of External Device where error occurs. Device name is a title of External Device set with GP-Pro EX. (Initial value [PLC1])
Error Message	Displays messages related to the error which occurs.
Error Occurrence Area	Displays IP address or device address of External Device where error occurs, or error codes received from External Device. NOTE <ul style="list-style-type: none"> • IP address is displayed such as "IP address (Decimal): MAC address (Hex)". • Device address is displayed such as "Address: Device address". • Received error codes are displayed such as "Decimal [Hex]".

Display Examples of Error Messages

"RHAA035: PLC1: Error has been responded for device write command (Error Code: 2 [02H])"

NOTE • Please refer to the manual of External Device for more detail of received error codes.

■ Error Code Peculiar to PLC

The error code peculiar to PLC is as follows.

Error	Code cause
01	Function code error
02	Address error for coil, input relay and register
03	Number error for coil, input relay and register

