



# ROBO CYLINDER MODBUS SIO Driver

1	System Configuration.....	3
2	Selection of External Device .....	7
3	Example of Communication Setting.....	8
4	Setup Items .....	20
5	Cable Diagram .....	25
6	Supported Device.....	147
7	Device Code and Address Code.....	148
8	Error Messages.....	149

## Introduction

This manual describes how to connect the Display and the External Device (target PLC).

In this manual, the connection procedure will be described by following the below sections:

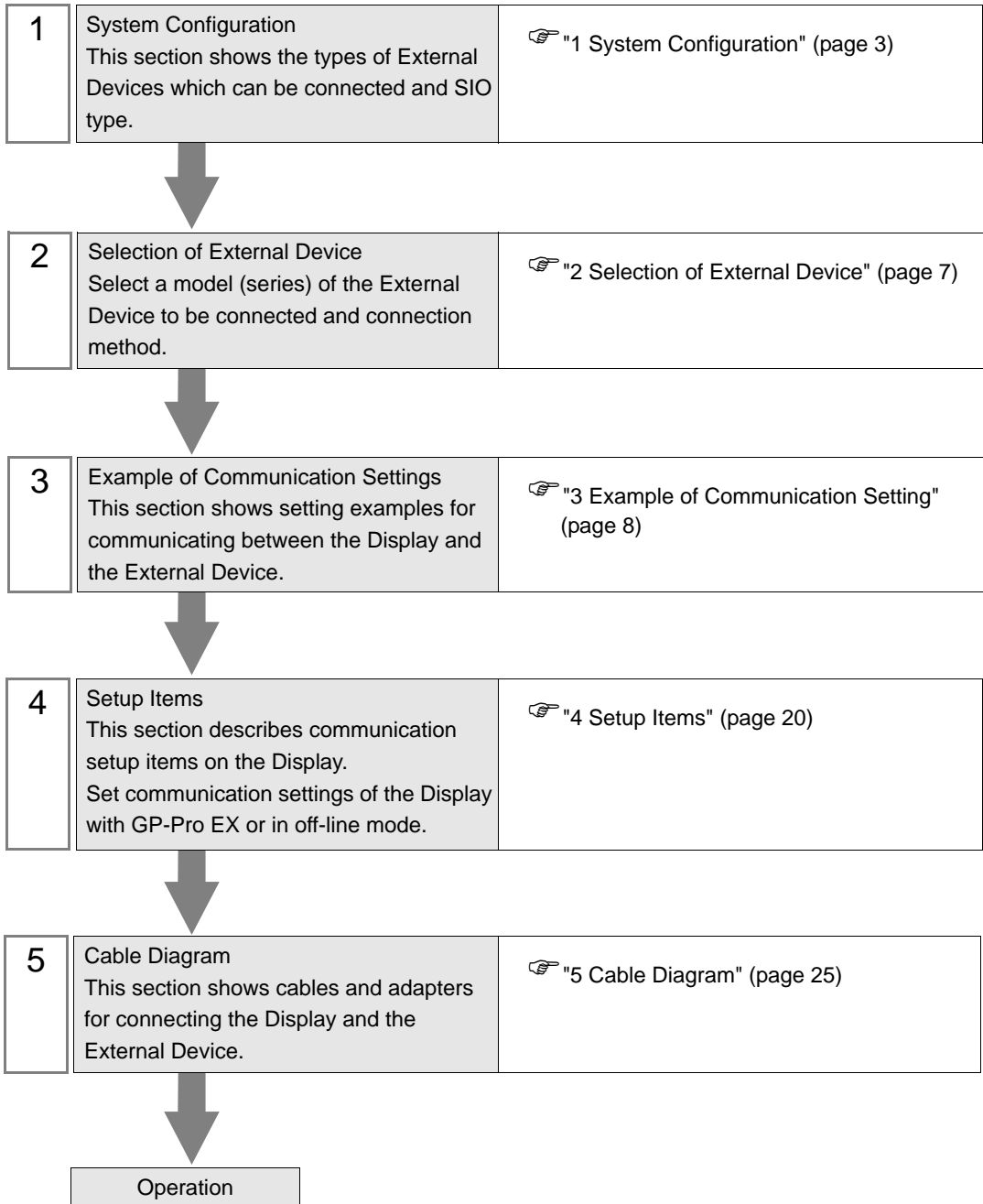

# 1 System Configuration

The system configuration in the case when the External Device of IAI Corporation and the Display are connected is shown.

Series	CPU	Link I/F	SIO Type	Setting Example	Cable Diagram	
PCON ACON SCON	PCON-□-□-□-□-□-□ ACON-□-□-□-□-□-□ SCON-□-□-□-□-□-□	SIO port	RS-232C	Setting Example 1 (page 8)	Cable Diagram 1 (page 25)	
			RS-422/485 (2 wire)	Setting Example 2 (page 10)	Cable Diagram 2 (page 27)	
		D-sub 9 pin connector on SIO converter (RC□-TU-SIO-□)	RS-232C	Setting Example 1 (page 8)	Cable Diagram 3 (page 37)	
		Mini-DIN 8 pin connector on SIO converter (RC□-TU-SIO-□)	RS-232C	Setting Example 1 (page 8)	Cable Diagram 4 (page 45)	
ERC2	ERC2-□-□-□-□-□-□-□-□-□-□ ERC2-□-□-□-□-□-□-□-□-□-□	Teach port	RS-232C	Setting Example 3 (page 12)	Cable Diagram 1 (page 25)	
			RS-422/485 (2 wire)	Setting Example 4 (page 14)	Cable Diagram 2 (page 27)	
		Cable on CPU	RS-422/485 (2 wire)	Setting Example 4 (page 14)	Cable Diagram 5 (page 53)	
			D-sub 9 pin connector on SIO converter (RC□-TU-SIO-□)	RS-232C	Setting Example 3 (page 12)	Cable Diagram 6 (page 64)
			Mini-DIN 8 pin connector on SIO converter (RC□-TU-SIO-□)	RS-232C	Setting Example 3 (page 12)	Cable Diagram 7 (page 81)
	ERC2-□-□-□-□-□-□-□-□-□-□	Cable on CPU	RS-232C	Setting Example 3 (page 12)	Cable Diagram 8 (page 98)	
			RS-422/485 (2 wire)	Setting Example 4 (page 14)	Cable Diagram 9 (page 99)	
		D-sub 9 pin connector on SIO converter (RC□-TU-SIO-□)	RS-232C	Setting Example 3 (page 12)	Cable Diagram 10 (page 112)	
		Mini-DIN 8 pin connector on SIO converter (RC□-TU-SIO-□)	RS-232C	Setting Example 3 (page 12)	Cable Diagram 11 (page 120)	

Series	CPU	Link I/F	SIO Type	Setting Example	Cable Diagram
ROBO NET*1	GateWayR RGW-SIO	Connector for network	RS-422/485 (2 wire)	Setting Example 5 (page 16)	Cable Diagram 12 (page 129)
		D-sub 9 pin connector on SIO converter (RC□-TU-SIO-□)	RS-232C	Setting Example 6 (page 18)	Cable Diagram 13 (page 134)
		Mini-DIN 8 pin connector on SIO converter (RC□-TU-SIO-□)	RS-232C	Setting Example 6 (page 18)	Cable Diagram 14 (page 140)

\*1 Support only the Gateway mode.

### ■ Connection Configuration

- 1:1 connection

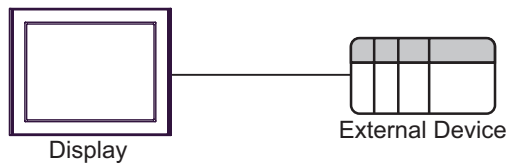

- 1:n connection (For use COM1 or COM2)

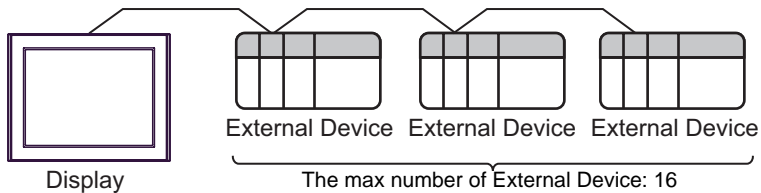

- 1:n connection (For use SIO converter)

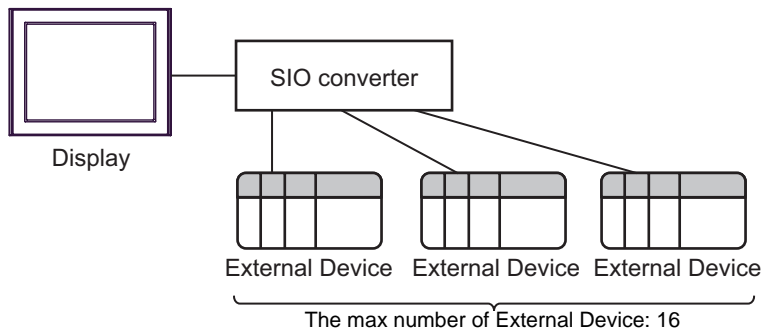

## ■ IPC COM Port

When connecting IPC with an External Device, the COM port used depends on the series and SIO type. Please refer to the IPC manual for details.

### Usable port

Series	Usable Port		
	RS-232C	RS-422/485(4 wire)	RS-422/485(2 wire)
PS-2000B	COM1 <sup>*1</sup> , COM2, COM3 <sup>*1</sup> , COM4	-	-
PS-3450A, PS-3451A, PS3000-BA, PS3001-BD	COM1, COM2 <sup>*1*2</sup>	COM2 <sup>*1*2</sup>	COM2 <sup>*1*2</sup>
PS-3650A, PS-3651A	COM1 <sup>*1</sup>	-	-
PS-3700A (Pentium®4-M) PS-3710A	COM1 <sup>*1</sup> , COM2 <sup>*1</sup> , COM3 <sup>*2</sup> , COM4	COM3 <sup>*2</sup>	COM3 <sup>*2</sup>
PS-3711A	COM1 <sup>*1</sup> , COM2 <sup>*2</sup>	COM2 <sup>*2</sup>	COM2 <sup>*2</sup>
PL-3000B, PL-3600T, PL-3600K, PL-3700T, PL-3700K, PL-3900T	COM1 <sup>*1*2</sup> , COM2 <sup>*1</sup> , COM3, COM4	COM1 <sup>*1*2</sup>	COM1 <sup>*1*2</sup>

\*1 The RI/5V can be switched. Use the IPC's switch to change if necessary.

\*2 Set up the SIO type with the DIP switch. Please set up as follows according to SIO type to be used.

### DIP switch setting: RS-232C

DIP switch	Setting	Description
1	OFF <sup>*1</sup>	Reserved (always OFF)
2	OFF	SIO type: RS-232C
3	OFF	
4	OFF	Output mode of SD (TXD) data: Always output
5	OFF	Terminal resistance (220Ω) insertion to SD (TXD): None
6	OFF	Terminal resistance (220Ω) insertion to RD (RXD): None
7	OFF	Short-circuit of SDA (TXA) and RDA (RXA): Not available
8	OFF	Short-circuit of SDB (TXB) and RDB (RXB): Not available
9	OFF	RS (RTS) Auto control mode: Disabled
10	OFF	

\*1 When using PS-3450A, PS-3451A, PS3000-BA and PS3001-BD, turn ON the set value.

## DIP switch setting: RS-422/485 (4 wire)

DIP switch	Setting	Description
1	OFF	Reserved (always OFF)
2	ON	SIO type: RS-422/485
3	ON	
4	OFF	Output mode of SD (TXD) data: Always output
5	OFF	Terminal resistance (220Ω) insertion to SD (TXD): None
6	OFF	Terminal resistance (220Ω) insertion to RD (RXD): None
7	OFF	Short-circuit of SDA (TXA) and RDA (RXA): Not available
8	OFF	Short-circuit of SDB (TXB) and RDB (RXB): Not available
9	OFF	RS (RTS) Auto control mode: Disabled
10	OFF	

## DIP switch setting: RS-422/485 (2 wire)

DIP switch	Setting	Description
1	OFF	Reserved (always OFF)
2	ON	SIO type: RS-422/485
3	ON	
4	OFF	Output mode of SD (TXD) data: Always output
5	OFF	Terminal resistance (220Ω) insertion to SD (TXD): None
6	OFF	Terminal resistance (220Ω) insertion to RD (RXD): None
7	ON	Short-circuit of SDA (TXA) and RDA (RXA): Available
8	ON	Short-circuit of SDB (TXB) and RDB (RXB): Available
9	ON	RS (RTS) Auto control mode: Enabled
10	ON	

## 2 Selection of External Device

Select the External Device to be connected to the Display.

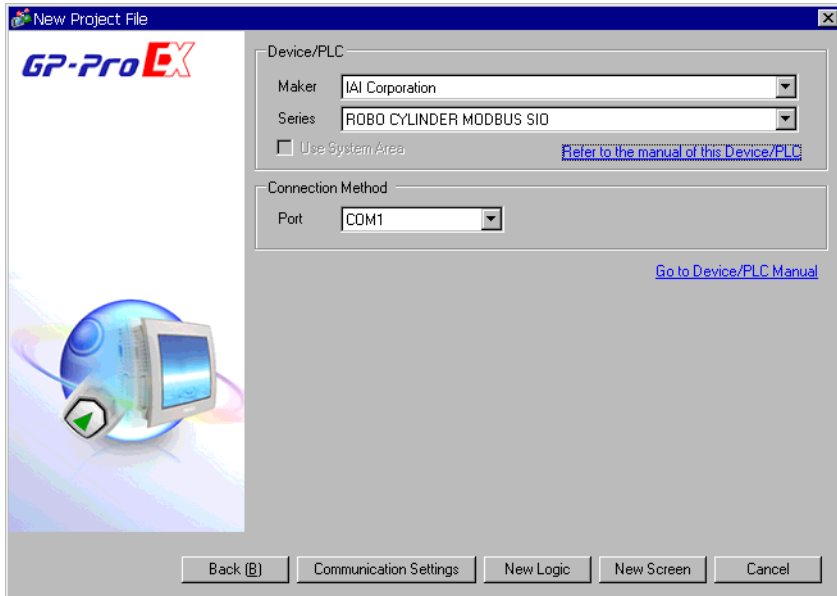

Setup Items	Setup Description
Maker	Select the maker of the External Device to be connected. Select "IAI Corporation."
Series	Select a model (series) of the External Device to be connected and connection method. Select "ROBO CYLINDER MODBUS SIO." Check the External Device which can be connected in "ROBO CYLINDER MODBUS SIO" in system configuration. ☞ "1 System Configuration" (page 3)
Use System Area	Check this option when you synchronize the system data area of Display and the device (memory) of External Device. When synchronized, you can use the ladder program of External Device to switch the display or display the window on the display. Cf. GP-Pro EX Reference Manual "LS Area (Direct Access Method Area)" This can also be set in GP-Pro EX or in the Display's off-line mode. Cf. GP-Pro EX Reference Manual "Display Unit (System Area) Settings Guide" Cf. Maintenance/Troubleshooting Manual "Main Unit - System Area Settings"
Port	Select the Display port to be connected to the External Device.

### 3 Example of Communication Setting

The following shows examples of communication settings of the Display and the External Device, which is recommended by Pro-face.

#### 3.1 Setting Example 1

##### ■ Setting of GP-Pro EX

##### ◆ Communication Settings

To display the setting screen, select [Device/PLC Settings] from [System setting window] in workspace.

The screenshot shows the 'Device/PLC 1' settings window. It includes a 'Summary' section with fields for 'Maker' (IAI Corporation), 'Series' (ROBO CYLINDER MODBUS SIO), and 'Port' (COM1). Below this is the 'Communication Settings' section with radio buttons for 'RS232C', 'RS422/485(2wire)', and 'RS422/485(4wire)'. Other settings include 'Speed' (38400), 'Data Length' (8), 'Parity' (NONE), 'Stop Bit' (1), 'Flow Control' (NONE), 'Timeout' (3 sec), 'Retry' (2), and 'Wait To Send' (2 ms). There is also a section for 'RI / VCC' with radio buttons for 'RI' and 'VCC'. At the bottom, there is a 'Device-Specific Settings' section with a table for 'Allowable Number of Devices/PLCs' (16) and a table for 'Number', 'Device Name', and 'Settings' (Axis No.=0).

##### ◆ Device Setting

To display the setting screen, click  ([Setting]) of External Device you want to set from [Device-Specific Settings] of [Device/PLC Settings].

When you connect multiple External Device, click  from [Device-Specific Settings] of [Device/PLC Settings] to add another External Device.

The screenshot shows the 'Individual Device Settings' dialog box for 'PLC1'. It has a text field for 'Axis No.' with the value '0'. Below the field is a note: 'Please input 62 for Axis No. when the node is Modbus Gateway mode of ROBONET. (This process sets "adrs" to "63".)'. There are 'Default', 'OK (O)', and 'Cancel' buttons.



## ■ Setting of External Device

Communication setting of External Device using MODE selector switch, Address switch and setting tool (PC Interface Software for RC) of External Device.

Please refer to the manual of the External Device for more details.

### ◆ Procedure

- 1 Set the MODE selector switch of External Device as follows.

MODE selector switch	Setting Value
Selector switch	MANU

- 2 Set the Address switch of External Device as follows.

Address switch	Setting Value
ADRS	0

- 3 Start up the setting tool.
- 4 Select [Teach mode1 (Safety speed effective/PIO start prohibition)] of a window to select manual operation mode.
- 5 Expand the axis number to be set from the tree view and click [Parameter].
- 6 Set [SIO Baudrate[bps]] of External Device as follows.

Setup Item	Setting Value
SIO Baudrate[bps]	38400

- 7 Select [Send to Controller] from the [Parameter] menu and send the set contents to the controller.

## 3.2 Setting Example 2

### ■ Setting of GP-Pro EX

#### ◆ Communication Settings

To display the setting screen, select [Device/PLC Settings] from [System setting window] in workspace.

#### ◆ Device Setting

To display the setting screen, click  ([Setting]) of External Device you want to set from [Device-Specific Settings] of [Device/PLC Settings].

When you connect multiple External Device, click  from [Device-Specific Settings] of [Device/PLC Settings] to add another External Device.

## ■ Setting of External Device

Communication setting of External Device using MODE selector switch, Address switch and setting tool (PC Interface Software for RC) of External Device.

Please refer to the manual of the External Device for more details.

### ◆ Procedure

- 1 Set the MODE selector switch of External Device as follows.

MODE selector switch	Setting Value
Selector switch	MANU

- 2 Set the Address switch of External Device as follows.

Address switch	Setting Value
ADRS	0

- 3 Start up the setting tool.
- 4 Select [Teach mode1 (Safety speed effective/PIO start prohibition)] of a window to select manual operation mode.
- 5 Expand the axis number to be set from the tree view and click [Parameter].
- 6 Set [SIO Baudrate[bps]] of External Device as follows.

Setup Item	Setting Value
SIO Baudrate[bps]	38400

- 7 Select [Send to Controller] from the [Parameter] menu and send the set contents to the controller.

### 3.3 Setting Example 3

#### ■ Setting of GP-Pro EX

##### ◆ Communication Settings

To display the setting screen, select [Device/PLC Settings] from [System setting window] in workspace.

##### ◆ Device Setting

To display the setting screen, click  ([Setting]) of External Device you want to set from [Device-Specific Settings] of [Device/PLC Settings].

When you connect multiple External Device, click  from [Device-Specific Settings] of [Device/PLC Settings] to add another External Device.

## ■ Setting of External Device

Communication setting of External Device using setting tool (PC Interface Software for RC) of External Device.  
Please refer to the manual of the External Device for more details.

### ◆ Procedure

- 1 Start up the setting tool.
- 2 Select [Teach mode1 (Safety speed effective/PIO start prohibition)] of a window to select manual operation mode.
- 3 Select [Controller Setup]-[Assign Axis Number] from [Setting] menu.
- 4 Set axis number of [Assign Axis Number] dialog box as follows, and click [OK].

Setup Item	Setting Value
New Assign Axis Number	0

- 5 Expand the axis number to be set from the tree view and click [Parameter].
- 6 Set [SIO Baudrate[bps]] of External Device as follows.

Setup Item	Setting Value
SIO Baudrate[bps]	38400

- 7 Select [Send to Controller] from the [Parameter] menu and send the set contents to the controller.

## 3.4 Setting Example 4

### ■ Setting of GP-Pro EX

#### ◆ Communication Settings

To display the setting screen, select [Device/PLC Settings] from [System setting window] in workspace.

#### ◆ Device Setting

To display the setting screen, click  ([Setting]) of External Device you want to set from [Device-Specific Settings] of [Device/PLC Settings].

When you connect multiple External Device, click  from [Device-Specific Settings] of [Device/PLC Settings] to add another External Device.

## ■ Setting of External Device

Communication setting of External Device using setting tool (PC Interface Software for RC) of External Device.  
Please refer to the manual of the External Device for more details.

### ◆ Procedure

- 1 Start up the setting tool.
- 2 Select [Teach mode1 (Safety speed effective/PIO start prohibition)] of a window to select manual operation mode.
- 3 Select [Controller Setup]-[Assign Axis Number] from [Setting] menu.
- 4 Set axis number of [Assign Axis Number] dialog box as follows, and click [OK].

Setup Item	Setting Value
New Assign Axis Number	0

- 5 Expand the axis number to be set from the tree view and click [Parameter].
- 6 Set [SIO Baudrate[bps]] of External Device as follows.

Setup Item	Setting Value
SIO Baudrate[bps]	38400

- 7 Select [Send to Controller] from the [Parameter] menu and send the set contents to the controller.

## 3.5 Setting Example 5

### ■ Setting of GP-Pro EX

#### ◆ Communication Settings

To display the setting screen, select [Device/PLC Settings] from [System setting window] in workspace.

#### ◆ Device Setting

To display the setting screen, click  ([Setting]) of External Device you want to set from [Device-Specific Settings] of [Device/PLC Settings].

When you connect multiple External Device, click  from [Device-Specific Settings] of [Device/PLC Settings] to add another External Device.



## ■ Setting of External Device

Communication setting of External Device using MODE switch, Axis address setting switch, User setting switches and setting tool (gateway parameter selection tool) of External Device.

Please refer to the manual of the External Device for more details.

### ◆ Procedure

- 1 Set the MODE switch of GateWayR unit as follows.

MODE switch	Setting Value
MODE	MANU

- 2 Set the Axis address setting switch of controller unit as follows.

Axis address setting switch	Setting Value
ADRS	0

- 3 Set the User setting switches of GateWayR unit as follows.

User setting switches	Setting Value
SW1	OFF
SW2	OFF
SW3	Always OFF
SW4	Always OFF

- 4 Start up the setting tool.

- 5 Click [Read].

- 6 Click [Yes] of [Confirmation] dialog box.

- 7 Click [OK] of [Information] dialog box.

- 8 Set the setup items as follows, and click [Write].

Setup Items	Setting Value
Baud Rate	38400
Axis Type	1

- 9 Click [Yes] of [Confirmation] dialog box, and restart.

- 10 Set the MODE switch of GateWayR unit as follows.

MODE Switch	Setting Value
MODE	AUTO

## 3.6 Setting Example 6

### ■ Setting of GP-Pro EX

#### ◆ Communication Settings

To display the setting screen, select [Device/PLC Settings] from [System setting window] in workspace.

Device/PLC 1

Summary [Change Device/PLC](#)

Maker: IAI Corporation Series: ROBO CYLINDER MODBUS SIO Port: COM1

Text Data Mode: 1 [Change](#)

Communication Settings

SIO Type:  RS232C  RS422/485(2wire)  RS422/485(4wire)

Speed: 38400

Data Length:  7  8

Parity:  NONE  EVEN  ODD

Stop Bit:  1  2

Flow Control:  NONE  ER(DTR/CTS)  XON/XOFF

Timeout: 3 (sec)

Retry: 2

Wait To Send: 2 (ms)

RI / VCC:  RI  VCC

In the case of RS232C, you can select the 9th pin to RI (Input) or VCC (5V Power Supply). If you use the Digital's RS232C Isolation Unit, please select it to VCC.

Default

Device-Specific Settings

Allowable Number of Devices/PLCs: 16

Number	Device Name	Settings
1	PLC1	Axis No.=62

#### ◆ Device Setting

To display the setting screen, click ([Setting]) of External Device you want to set from [Device-Specific Settings] of [Device/PLC Settings].

When you connect multiple External Device, click from [Device-Specific Settings] of [Device/PLC Settings] to add another External Device.

Individual Device Settings

PLC1

Axis No.: 62

Please input 62 for Axis No. when the node is Modbus Gateway mode of ROBONET. (This process sets "axis" to "63".)

Default

OK (O) Cancel

## ■ Setting of External Device

Communication setting of External Device using MODE switch, Axis address setting switch, User setting switches and setting tool (gateway parameter selection tool) of External Device.

Please refer to the manual of the External Device for more details.

### ◆ Procedure

- 1 Set the MODE switch of GateWayR unit as follows.

MODE switch	Setting Value
MODE	MANU

- 2 Set the Axis address setting switch of controller unit as follows.

Axis address setting switch	Setting Value
ADRS	0

- 3 Set the User setting switches of GateWayR unit as follows.

User setting switches	Setting Value
SW1	OFF
SW2	OFF
SW3	Always OFF
SW4	Always OFF

- 4 Start up the setting tool.

- 5 Click [Read].

- 6 Click [Yes] of [Confirmation] dialog box.

- 7 Click [OK] of [Information] dialog box.

- 8 Set the setup items as follows, and click [Write].

Setup Items	Setting Value
Baud Rate	38400
Axis Type	1

- 9 Click [Yes] of [Confirmation] dialog box, and restart.

- 10 Set the MODE switch of GateWayR unit as follows.

MODE Switch	Setting Value
MODE	AUTO

## 4 Setup Items

Set communication settings of the Display with GP-Pro EX or in off-line mode of the Display.

The setting of each parameter must be identical to that of External Device.

☞ "3 Example of Communication Setting" (page 8)

### 4.1 Setup Items in GP-Pro EX

#### ■ Communication Settings

To display the setting screen, select [Device/PLC Settings] from [System setting window] in workspace.

Device/PLC 1

Summary [Change Device/PLC](#)

Maker  Series  Port

Text Data Mode  [Change](#)

Communication Settings

SIO Type  RS232C  RS422/485(2wire)  RS422/485(4wire)

Speed

Data Length  7  8

Parity  NONE  EVEN  ODD

Stop Bit  1  2

Flow Control  NONE  ER(DTR/CTS)  XON/XOFF

Timeout  (sec)

Retry

Wait To Send  (ms)

RI / VCC  RI  VCC

In the case of RS232C, you can select the 9th pin to RI (Input) or VCC (5V Power Supply). If you use the Digital's RS232C Isolation Unit, please select it to VCC.

Device-Specific Settings

Allowable Number of Devices/PLCs

Number	Device Name	Settings
<input type="text" value="1"/>	<input type="text" value="PLC1"/>	<input type="text" value="Axis No.=0"/>

Setup Items	Setup Description
SIO Type	Select the SIO type to communicate with the External Device.
Speed	Select speed between the External Device and the Display.
Data Length	Display data length.
Parity	Select how to check parity.
Stop Bit	Select stop bit length.
Flow Control	Select the communication control method to prevent overflow of transmission and reception data.
Timeout	Use an integer from 1 to 127 to enter the time (s) for which the Display waits for the response from the External Device.
Retry	In case of no response from the External Device, use an integer from 0 to 255 to enter how many times the Display retransmits the command.
Wait To Send	Use an integer from 0 to 255 to enter standby time (ms) for the Display from receiving packets to transmitting next commands.
RI/VCC	You can switch RI/VCC of the 9th pin when you select RS232C for SIO type. It is necessary to change RI/5V by changeover switch of IPC when connect with IPC. Please refer to the manual of the IPC for more detail.

## ■ Device Setting

To display the setting screen, click  ([Setting]) of External Device you want to set from [Device-Specific Settings] of [Device/PLC Settings].

When you connect multiple External Device, click  from [Device-Specific Settings] of [Device/PLC Settings] to add another External Device.

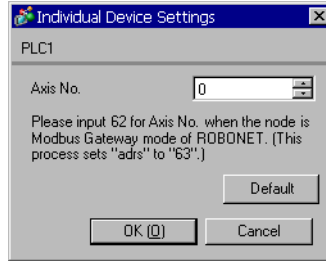

Setup Items	Setup Description
Axis No.	When the External Device is other than the ROBONET Modbus gateway mode, input any number from 0 to 15 in the axis number. When the External Device is the ROBONET Modbus gateway, input 62 in the axis number.

## 4.2 Setup Items in Off-Line Mode

**NOTE**

- Refer to the Maintenance/Troubleshooting manual for information on how to enter off-line mode or about the operation.
- Cf. Maintenance/Troubleshooting Manual "Off-line Mode"
- The number of the setup items to be displayed for 1 page in the off-line mode depends on the Display in use. Please refer to the Reference manual for details.

### ■ Communication Settings

To display the setting screen, touch [Device/PLC Settings] from [Peripheral Settings] in off-line mode. Touch the External Device you want to set from the displayed list.

Comm.	Device	Option		
ROBO CYLINDER MODBUS SIO		[COM1]	Page 1/1	
SIO Type	RS232C			
Speed	38400			
Data Length	8			
Parity	<input checked="" type="radio"/> NONE <input type="radio"/> EVEN <input type="radio"/> ODD			
Stop Bit	<input checked="" type="radio"/> 1 <input type="radio"/> 2			
Flow Control	NONE			
Timeout(s)		3	▼	▲
Retry		2	▼	▲
Wait To Send(ms)		2	▼	▲
Exit		Back		2007/12/19 21:46:22

Setup Items	Setup Description
SIO Type	Select the SIO type to communicate with the External Device. <b>IMPORTANT</b> To make the communication settings correctly, confirm the serial interface specifications of Display unit for [SIO Type]. We cannot guarantee the operation if a communication type that the serial interface does not support is specified. For details concerning the serial interface specifications, refer to the manual for Display unit.
Speed	Select speed between the External Device and the Display.
Data Length	Display data length.
Parity	Select how to check parity.
Stop Bit	Select stop bit length.
Flow Control	Select the communication control method to prevent overflow of transmission and reception data.

Continues to the next page.

Setup Items	Setup Description
Timeout (s)	Use an integer from 1 to 127 to enter the time (s) for which the Display waits for the response from the External Device.
Retry	In case of no response from the External Device, use an integer from 0 to 255 to enter how many times the Display retransmits the command.
Wait To Send (ms)	Use an integer from 0 to 255 to enter standby time (ms) for the Display from receiving packets to transmitting next commands.

## ■ Device Setting

To display the setting screen, touch [Device/PLC Settings] from [Peripheral Equipment Settings]. Touch the External Device you want to set from the displayed list, and touch [Device Settings].

Comm.	Device	Option		
ROBO CYLINDER MODBUS SIO		[COM1]	Page 1/1	
Device/PLC Name		[PLC1]		
Axis No.		[ 0 ]		
Please input 62 for Axis No. when the node is Modbus Gateway mode of ROBONET. (This process sets Adrs to 63.)				
Exit		Back		2007/12/19 21:46:26

Setup Items	Setup Description
Device/PLC name	Select the External Device to set. Device name is a title of the External Device set with GP-Pro EX. (Initial value [PLC1])
Axis No.	When the External Device is other than the ROBONET Modbus gateway mode, input any number from 0 to 15 in the axis number. When the External Device is the ROBONET Modbus gateway, input 62 in the axis number.

■ Option

To display the setting screen, touch [Device/PLC Settings] from [Peripheral Equipment Settings]. Touch the External Device you want to set from the displayed list, and touch [Option].

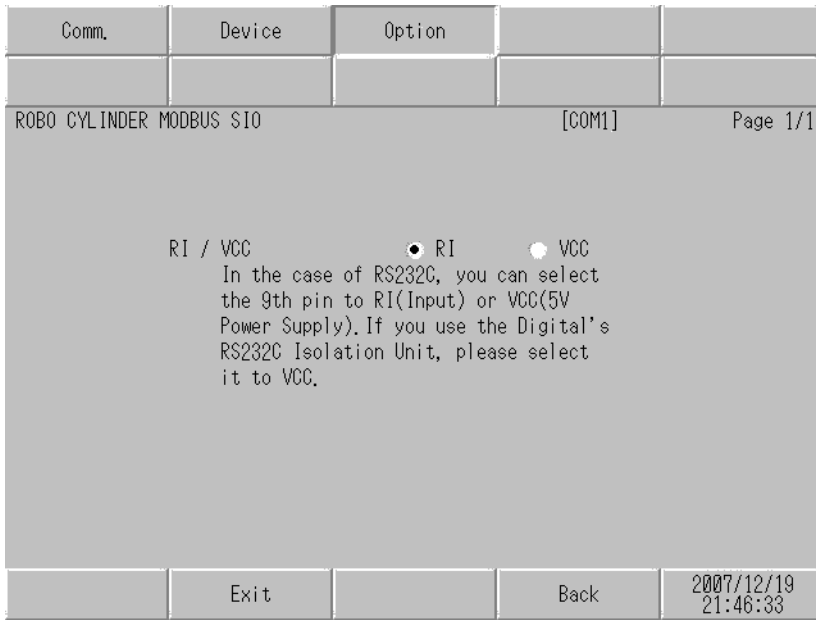

Setup Items	Setup Description
RI/VCC	Switches RI/VCC of the 9th pin. It is necessary to change RI/5V by changeover switch of IPC when connect with IPC. Please refer to the manual of the IPC for more detail.

**NOTE**

- GP-4100 series do not have the [Option] setting in the off-line mode.



## 5 Cable Diagram

The cable diagram shown below may be different from the cable diagram recommended by IAI Corporation.

Please be assured there is no operational problem in applying the cable diagram shown in this manual.

- The FG pin of the External Device body must be D-class grounded. Please refer to the manual of the External Device for more details.
- SG and FG are connected inside the Display. When connecting SG to the External Device, design the system not to form short-circuit loop.
- Connect the isolation unit, when communication is not stabilized under the influence of a noise etc.
- Make the External Device and 0V of SIO converter common.

Cable Diagram 1

Display (Connection Port)	Cable		Notes
GP3000 (COM1) ST (COM1) LT (COM1) IPC*1 PC/AT	1A	RS232C conversion unit by IAI Corporation RCB-CV-MW + Communication cable by IAI Corporation CB-RCA-SIO050	
GP-4105 (COM1)	1B	User-created cable + RS232C conversion unit by IAI Corporation RCB-CV-MW + Communication cable by IAI Corporation CB-RCA-SIO050	

\*1 Only the COM port which can communicate by RS-232C can be used.

 ■ IPC COM Port (page 5)

### NOTE

- RS232C conversion unit (RCB-CV-MW) and communication cable (CB-RCA-SIO050) are accessories of PC Interface Software (RCM-101-MW) by IAI Corporation.

1A)

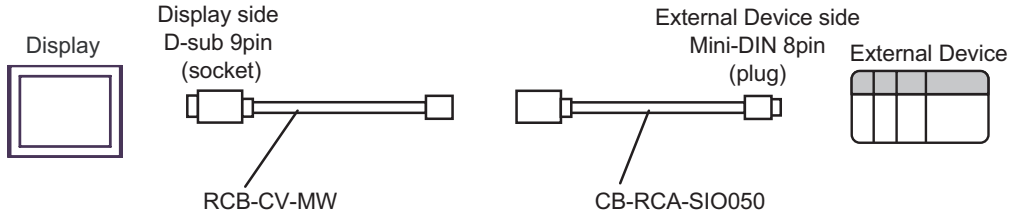

1B)

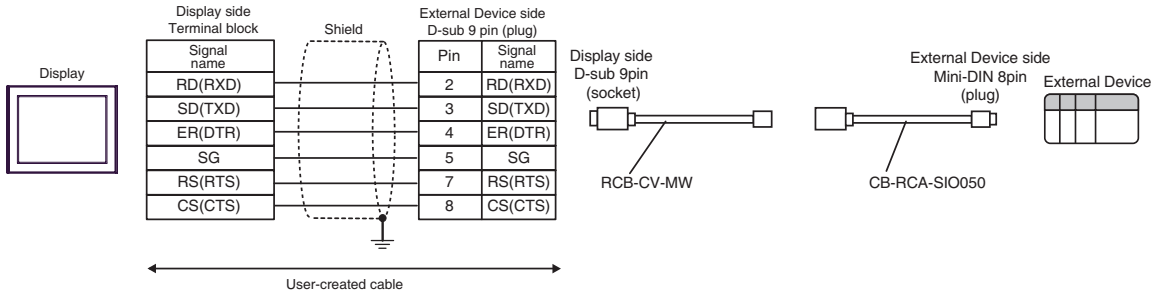

Cable Diagram 2

Display (Connection Port)	Cable		Notes
GP3000* <sup>1</sup> (COM1) AGP-3302B (COM2) ST* <sup>2</sup> (COM2) LT (COM1)	2A	COM port conversion adapter by Pro-face CA3-ADPCOM-01 + Terminal block conversion adapter by Pro-face CA3-ADPTRM-01 + User-created cable 1 + Junction by AMP* <sup>3</sup> 5-1473574-4 + Controller link cable by IAI Corporation CB-RCB-CTL002	Cable length: 100m or less
	2B	User-created cable 1 + Junction by AMP* <sup>3</sup> 5-1473574-4 + Controller link cable by IAI Corporation CB-RCB-CTL002	
GP3000* <sup>4</sup> (COM2)	2C	Online adapter by Pro-face CA4-ADPONL-01 + Terminal block conversion adapter by Pro-face CA3-ADPTRM-01 + User-created cable 1 + Junction by AMP* <sup>3</sup> 5-1473574-4 + Controller link cable by IAI Corporation CB-RCB-CTL002	
	2D	Online adapter by Pro-face CA4-ADPONL-01 + User-created cable 1 + Junction by AMP* <sup>3</sup> 5-1473574-4 + Controller link cable by IAI Corporation CB-RCB-CTL002	

continued to next page

Display (Connection Port)	Cable		Notes
IPC*5	2E	COM port conversion adapter by Pro-face CA3-ADPCOM-01 + Terminal block conversion adapter by Pro-face CA3-ADPTRM-01 + User-created cable 1 + Junction by AMP*3 5-1473574-4 + Controller link cable by IAI Corporation CB-RCB-CTL002	Cable length: 100m or less
	2F	User-created cable 1 + Junction by AMP*3 5-1473574-4 + Controller link cable by IAI Corporation CB-RCB-CTL002	
GP-4106 (COM1)	2G	User-created cable 1 + Junction by AMP*3 5-1473574-4 + Controller link cable by IAI Corporation CB-RCB-CTL002	
GP-4107 (COM1)	2H	User-created cable 1 + Junction by AMP*3 5-1473574-4 + Controller link cable by IAI Corporation CB-RCB-CTL002	

\*1 All GP3000 models except AGP-3302B

\*2 All ST models except AST-3211A and AST-3302B

\*3 When using more than one junction by AMP, user-created cable 2 is required.

\*4 All GP3000 models except GP-3200 series and AGP-3302B

\*5 Only the COM port which can communicate by RS-422/485 (2 wire) can be used.

 ■ IPC COM Port (page 5)

2A)

- 1:1 connection

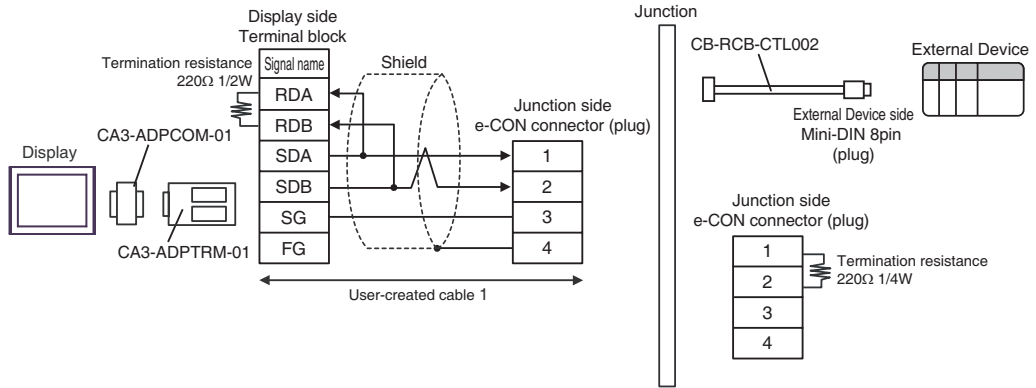

- 1:n connection

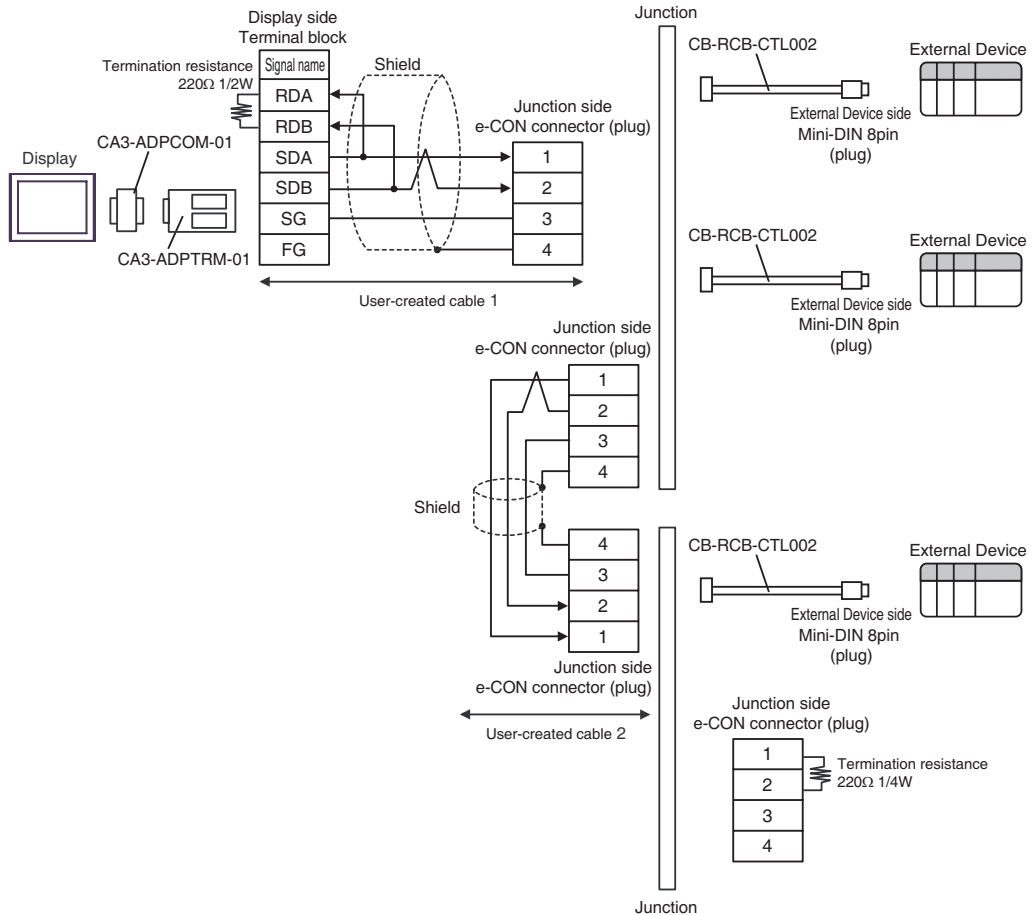

2B)

- 1:1 connection

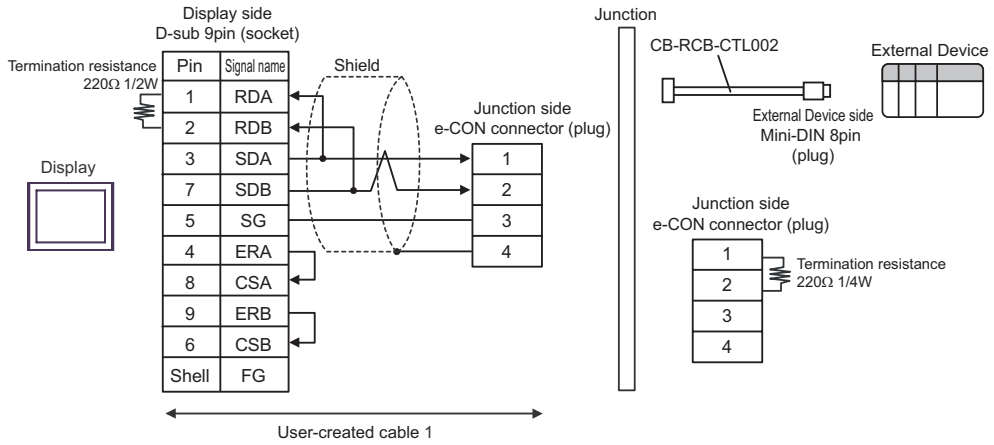

- 1:n connection

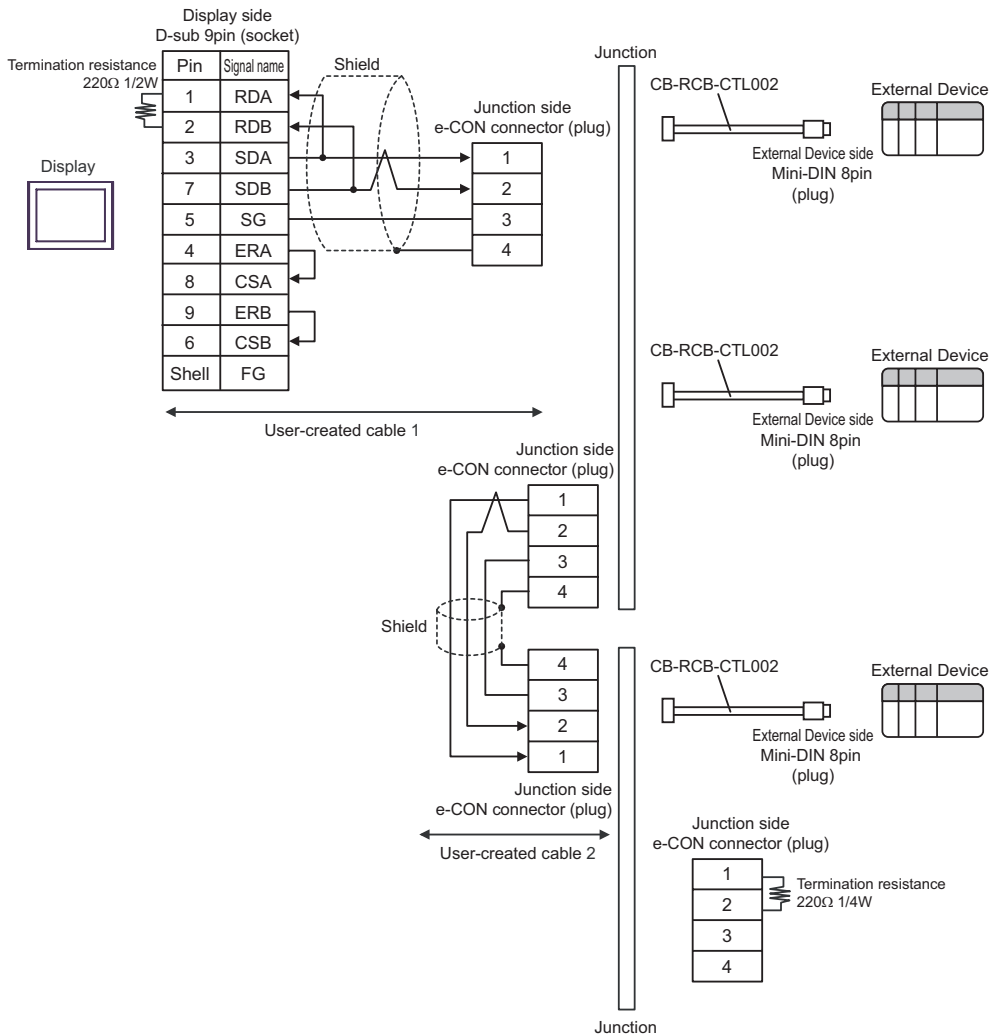

2C)

- 1:1 connection

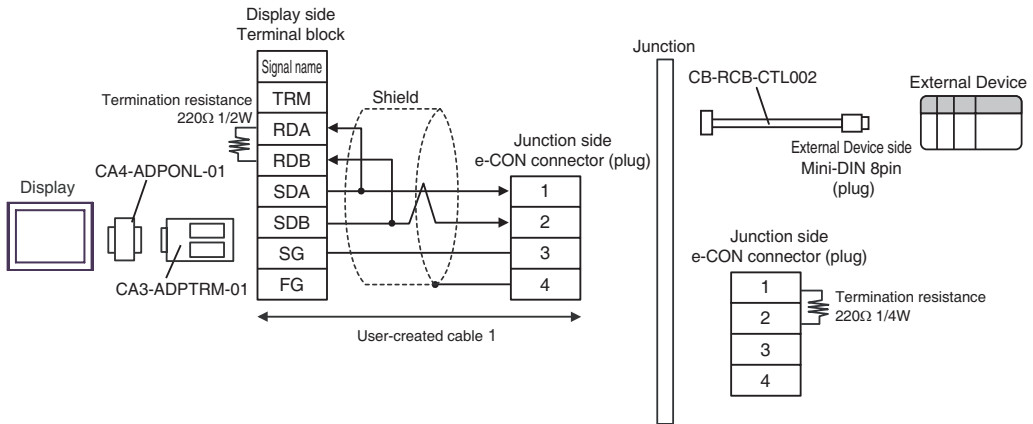

- 1:n connection

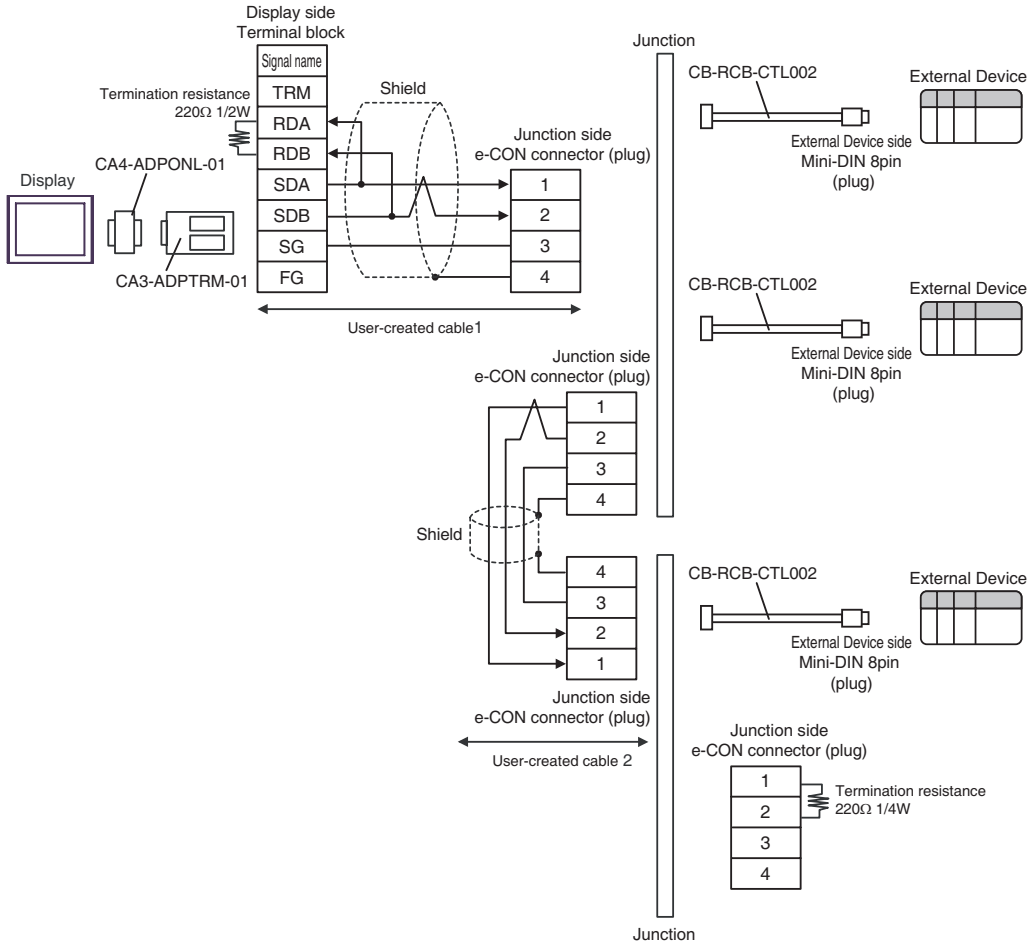

2D)

- 1:1 connection

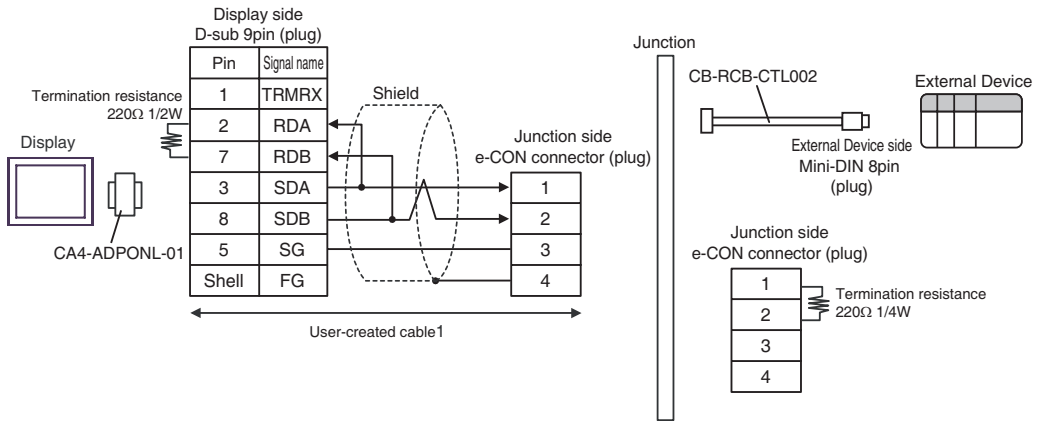

- 1:n connection

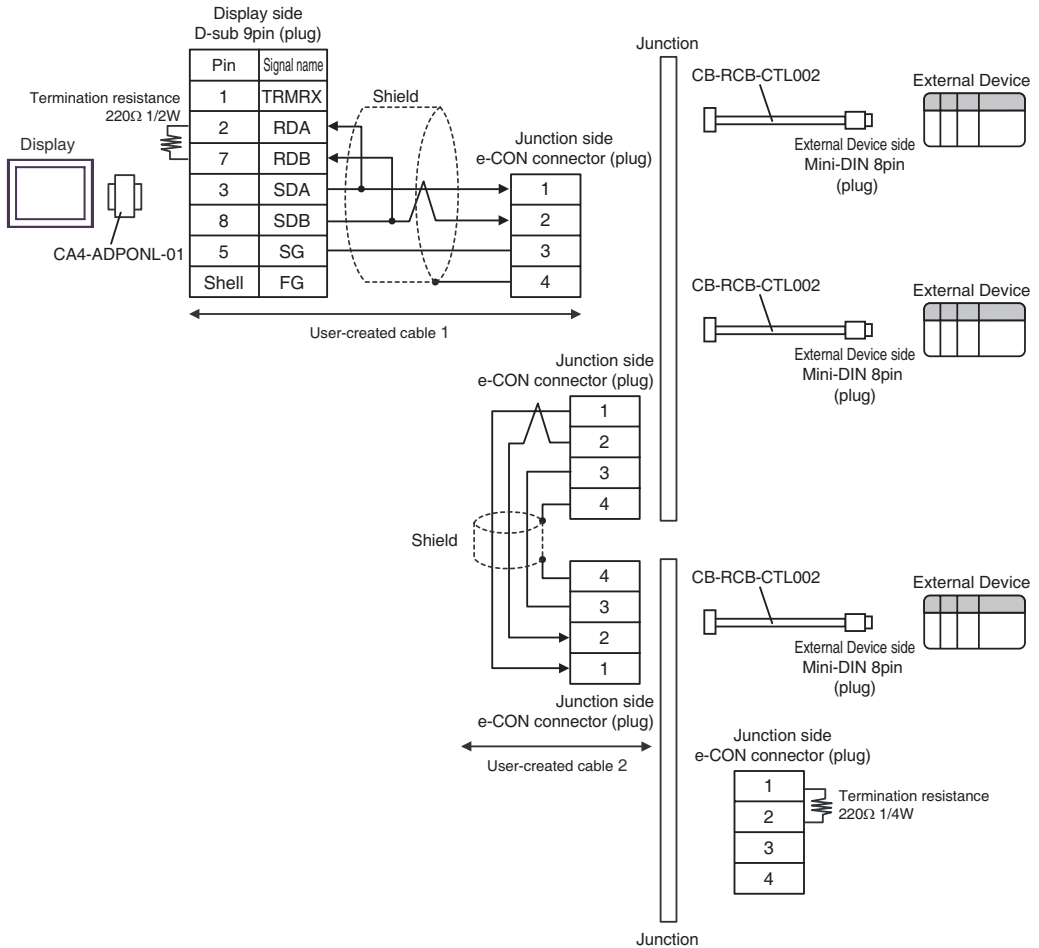



2E)

- 1:1 connection

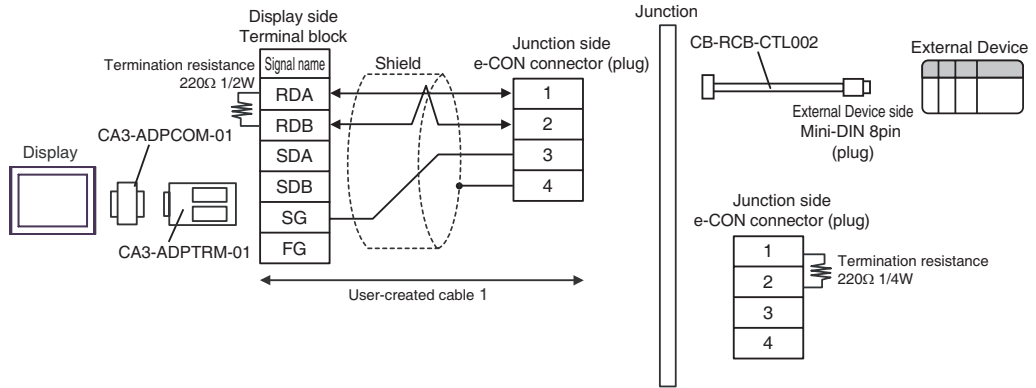

- 1:n connection

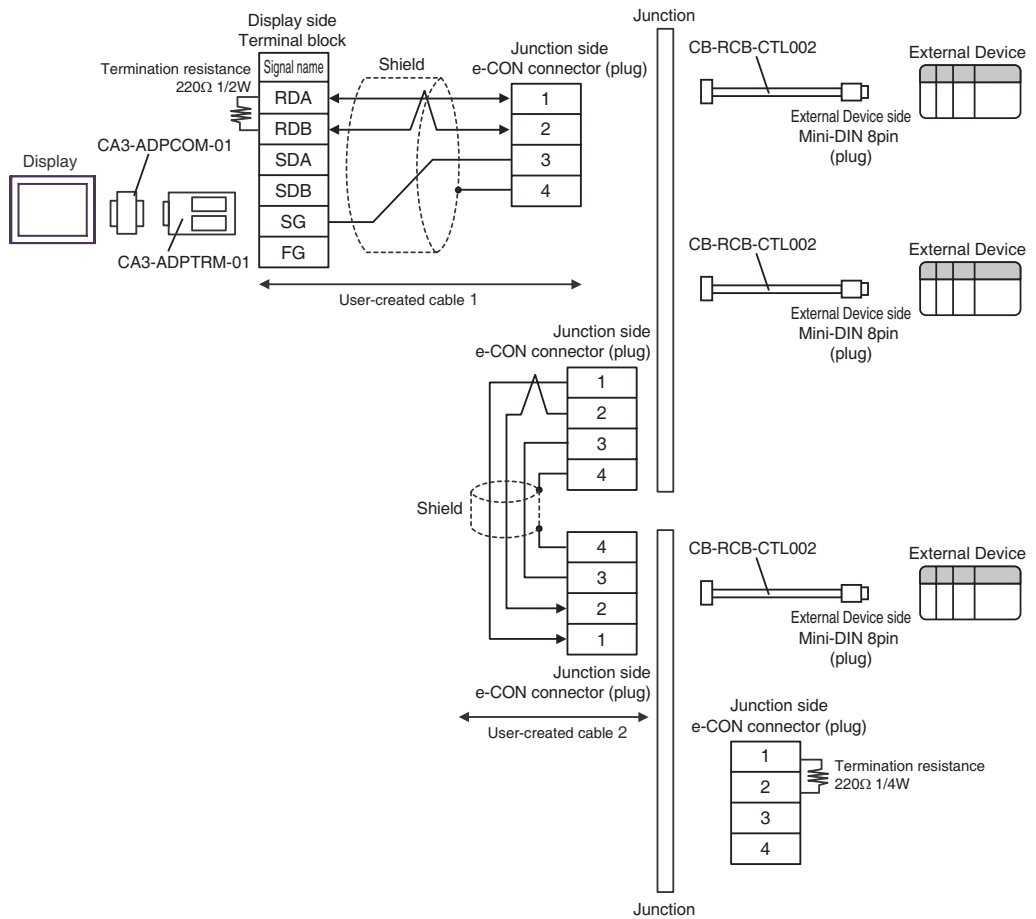

2F)

- 1:1 connection

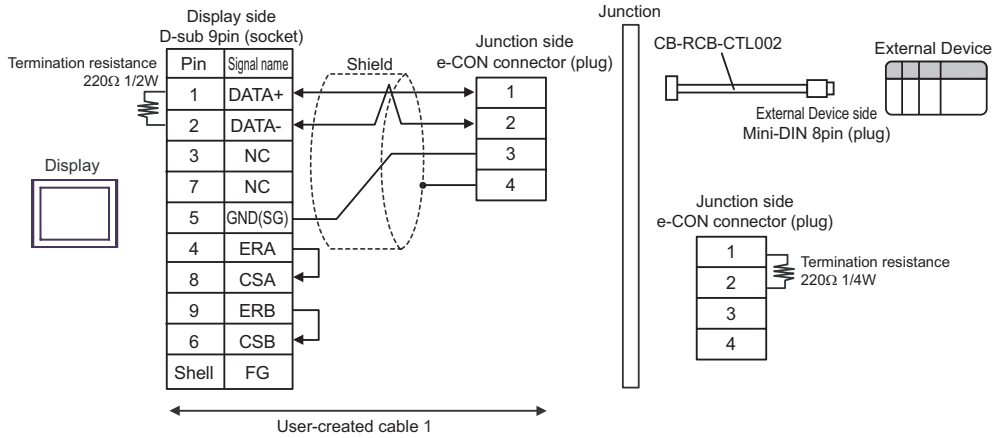

- 1:n connection

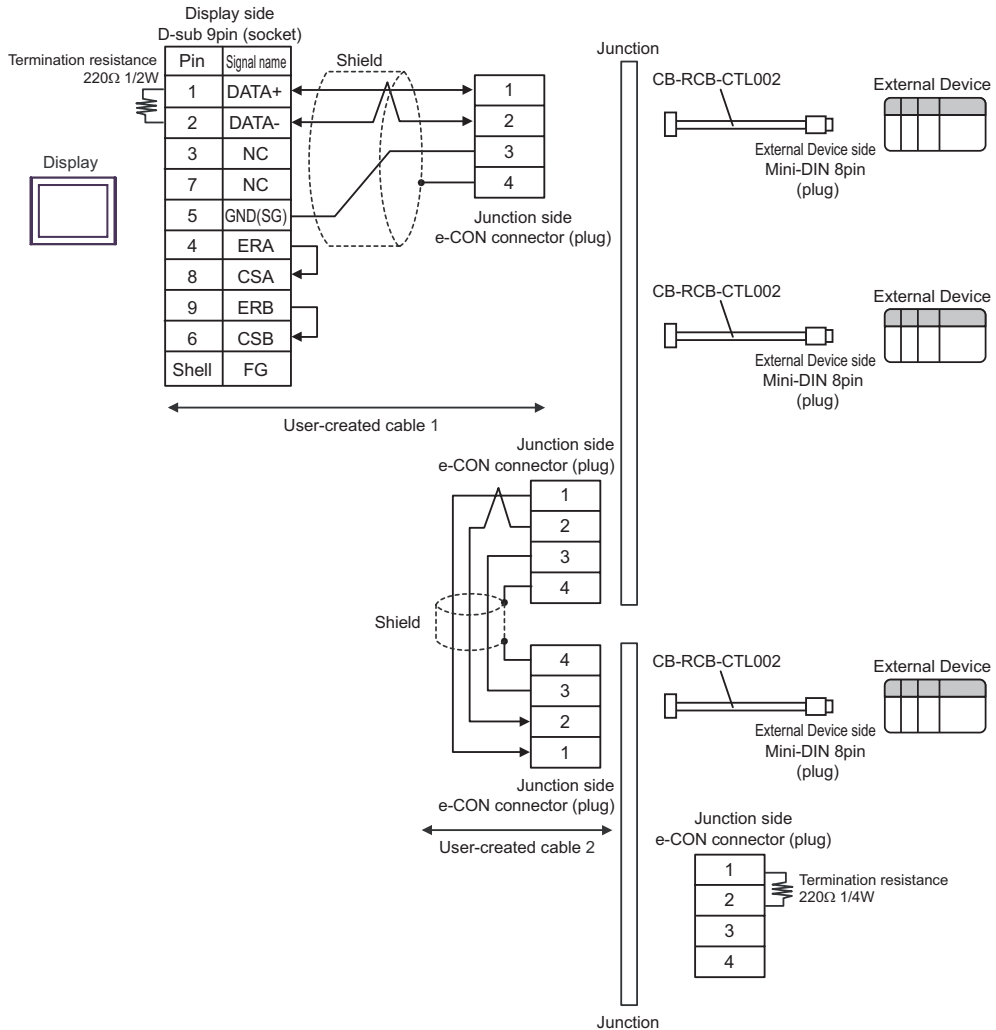

2G)

- 1:1 connection

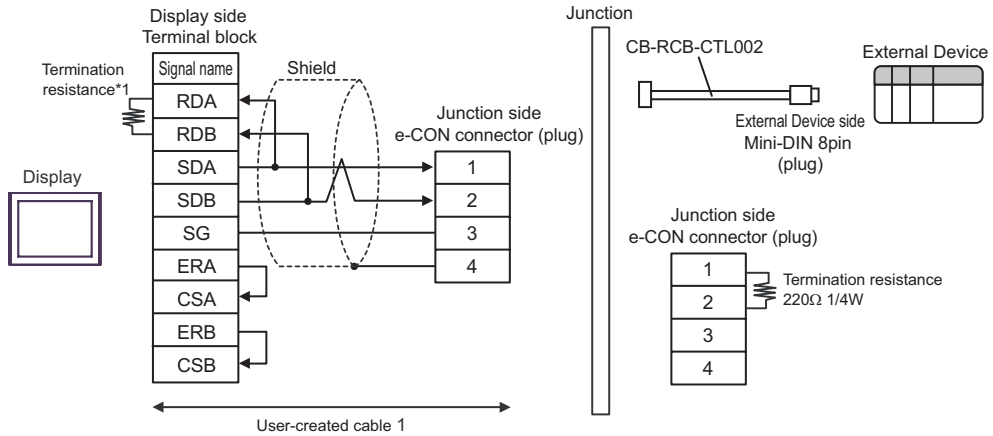

- 1:n connection

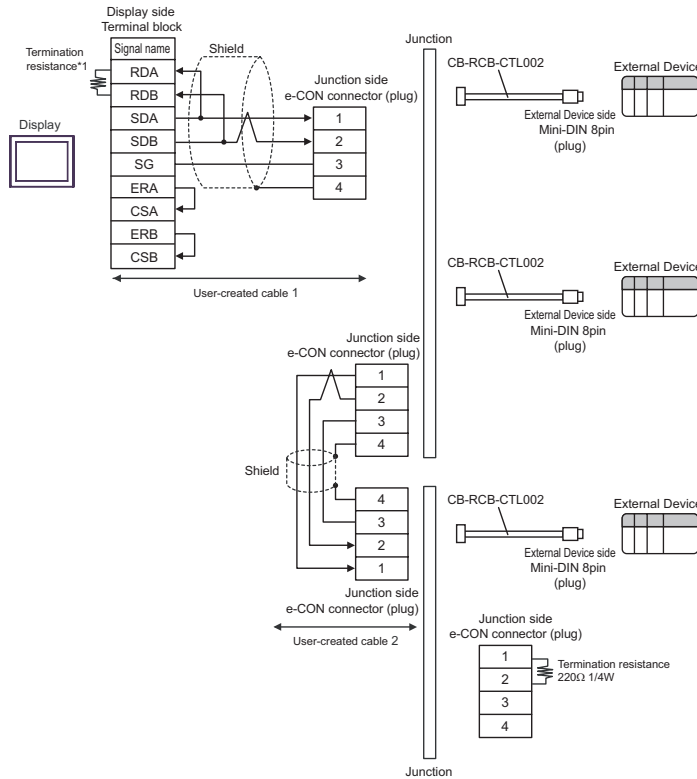

\*1 The resistance in the Display is used as the termination resistance. Set the value of the DIP Switch on the rear of the Display as shown in the table below.

DIP Switch No.	Set Value
1	OFF
2	OFF
3	OFF
4	ON

2H)

- 1:1 connection

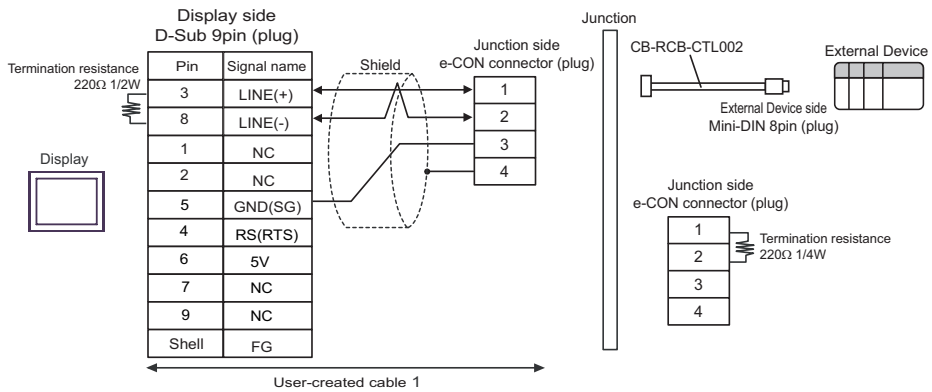

- 1:n connection

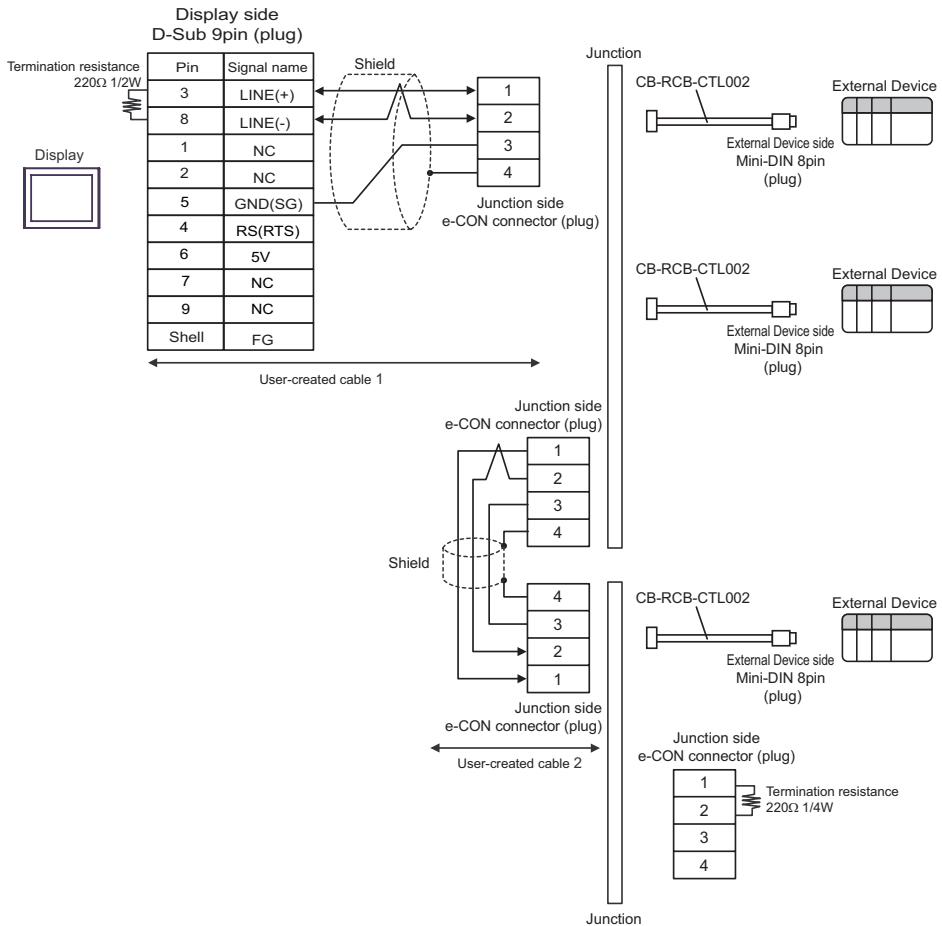

**IMPORTANT**

- The 5V output (Pin #6) on the GP-4107 is the power for the Siemens AG's PROFIBUS connector. Do not use it for other devices.

**NOTE**

- In COM on the GP-4107, the SG and FG terminals are isolated.

Cable Diagram 3

Display (Connection Port)	Cable		Notes
GP3000 (COM1) ST (COM1) LT (COM1) IPC*1 PC/AT	3A	User-created cable + SIO converter by IAI Corporation RC□-TU-SIO-□ + Controller link cable by IAI Corporation CB-RCB-CTL002	Cable length from Display to SIO converter: 15m or less  Cable length from SIO converter to External Device: 100m or less
	3B	User-created cable 1 + SIO converter by IAI Corporation RC□-TU-SIO-□ + User-created cable 2 + Junction by AMP*2 5-1473574-4 + Controller link cable by IAI Corporation CB-RCB-CTL002	
	3C	User-created cable 1 + SIO converter by IAI Corporation RC□-TU-SIO-□ + User-created cable 2 + Junction by AMP*2 5-1473574-4 + Controller link cable by IAI Corporation CB-RCB-CTL002	

continued to next page

Display (Connection Port)	Cable		Notes
GP-4105 (COM1)	3D	User-created cable + SIO converter by IAI Corporation RC□-TU-SIO-□ + Controller link cable by IAI Corporation CB-RCB-CTL002	Cable length from Display to SIO converter: 15m or less  Cable length from SIO converter to External Device: 100m or less
	3E	User-created cable 1 + SIO converter by IAI Corporation RC□-TU-SIO-□ + User-created cable 2 + Junction by AMP* <sup>2</sup> 5-1473574-4 + Controller link cable by IAI Corporation CB-RCB-CTL002	
	3F	User-created cable 1 + SIO converter by IAI Corporation RC□-TU-SIO-□ + User-created cable 2 + Junction by AMP* <sup>2</sup> 5-1473574-4 + Controller link cable by IAI Corporation CB-RCB-CTL002	

\*1 Only the COM port which can communicate by RS-232C can be used.

 ■ IPC COM Port (page 5)

\*2 When using more than one junction by AMP, user-created cable 3 is required.

3A)

- 1:1 connection

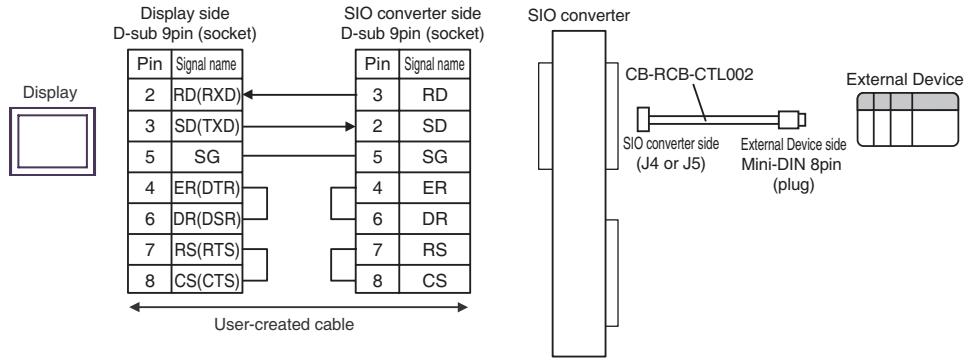

- 1:n connection

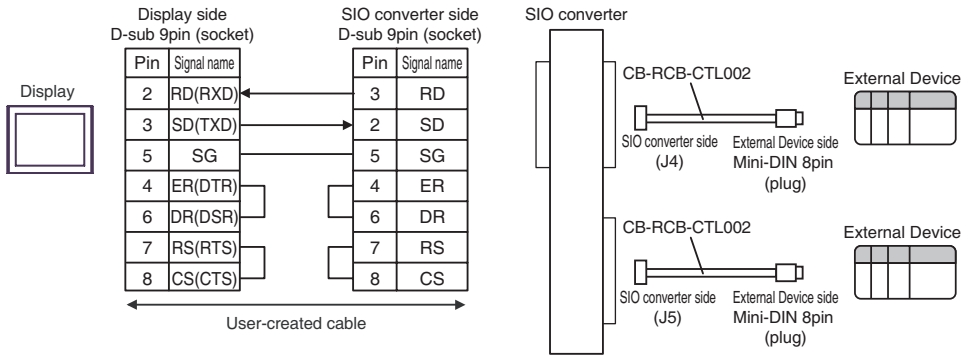

3B)

- 1:1 connection

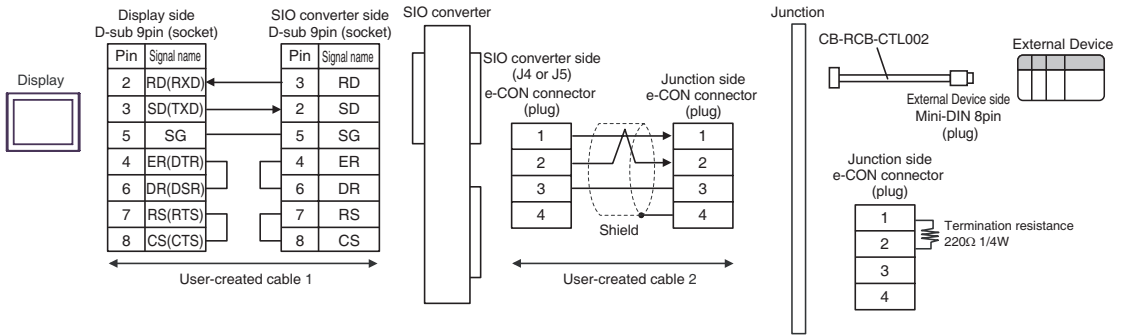

- 1:n connection

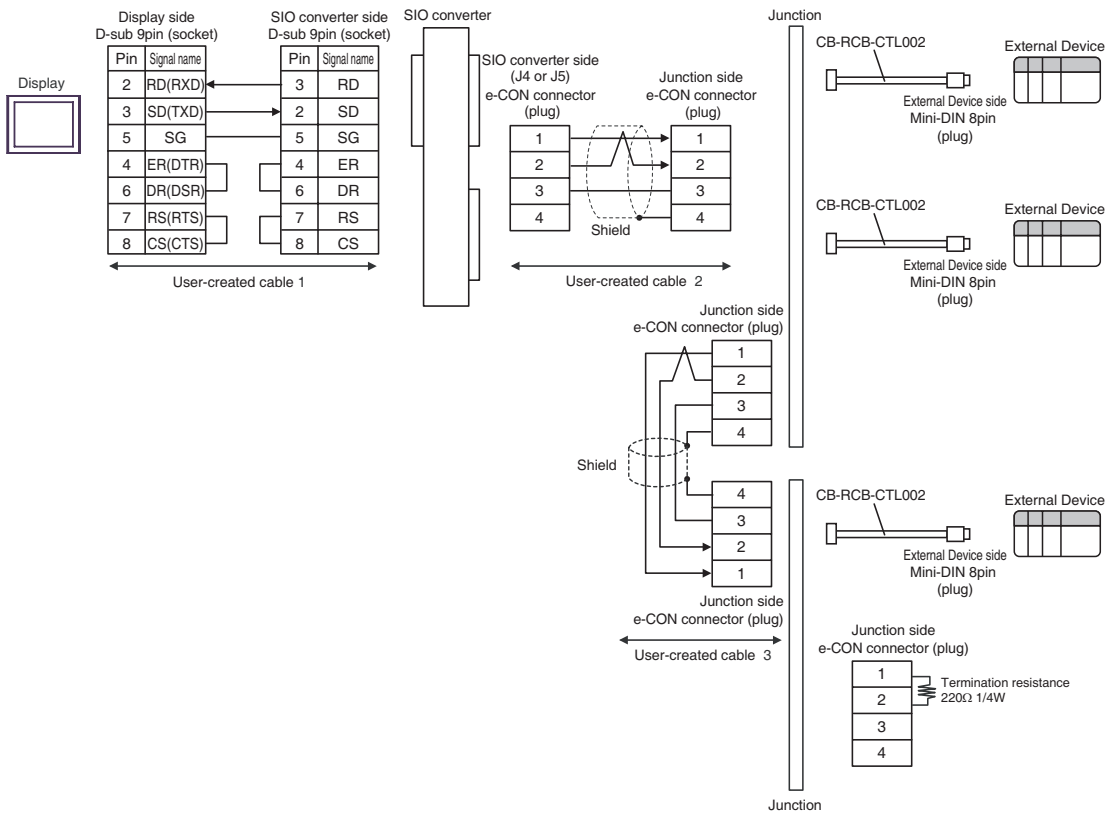



3C)

- 1:1 connection

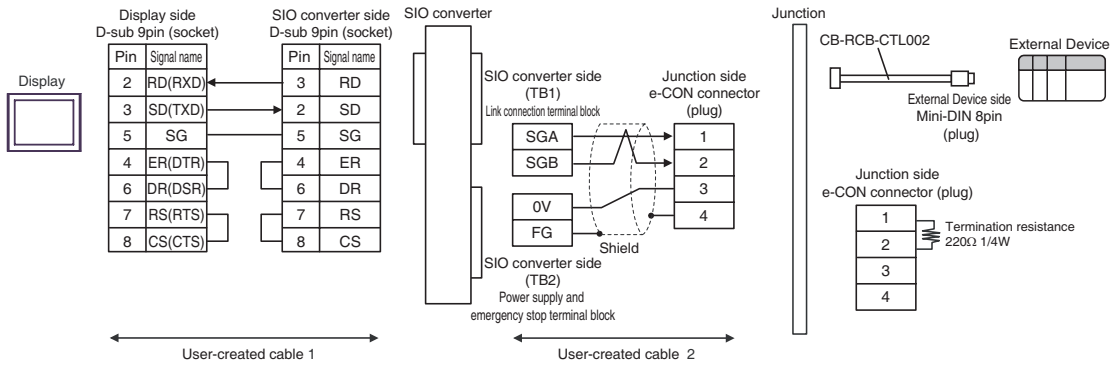

- 1:n connection

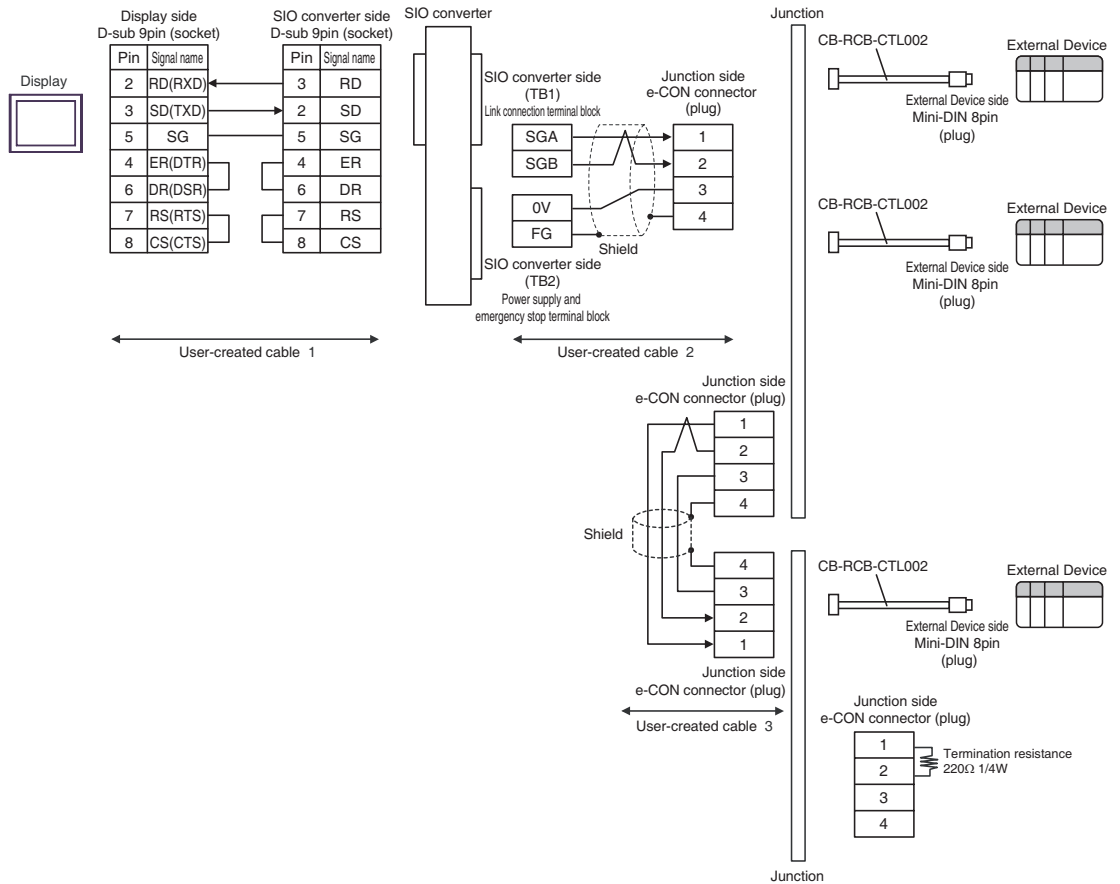

3D)

- 1:1 connection

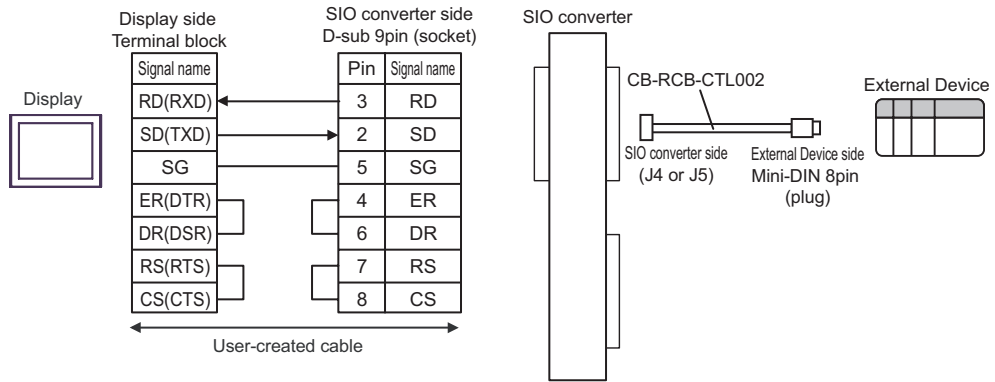

- 1:n connection

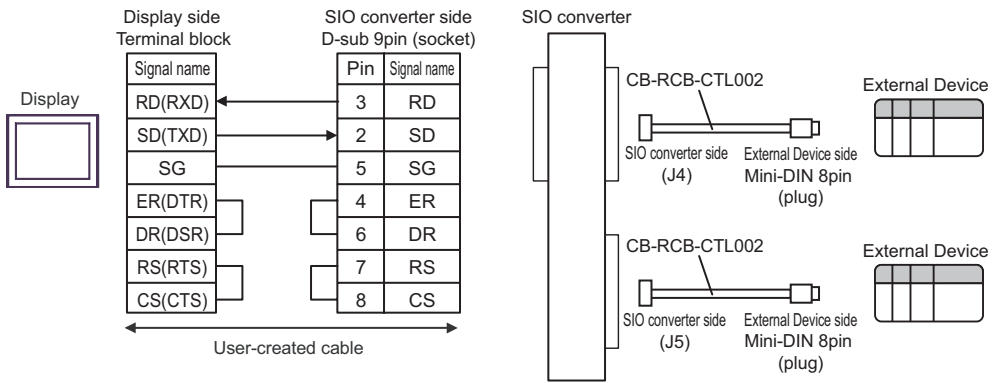

3E)

• 1:1 connection

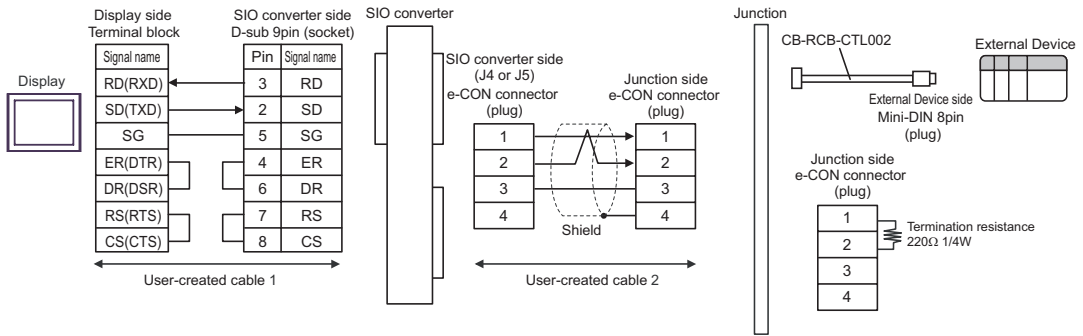

• 1:n connection

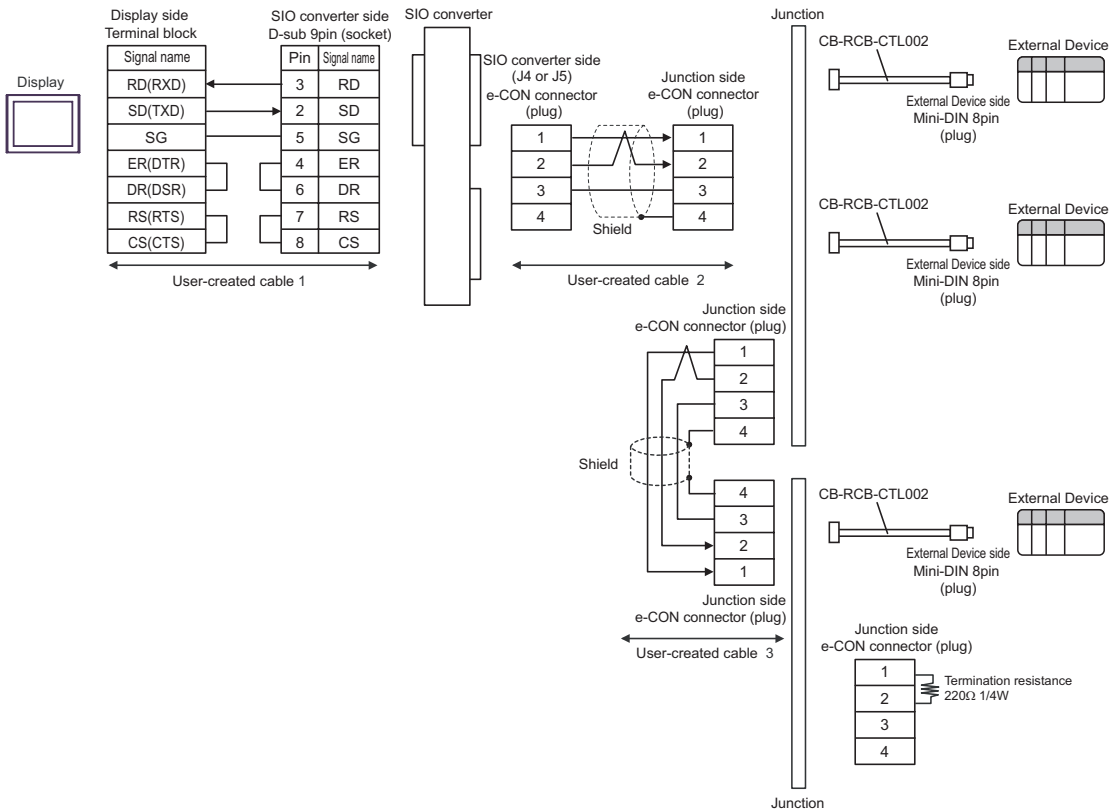

3F)

- 1:1 connection

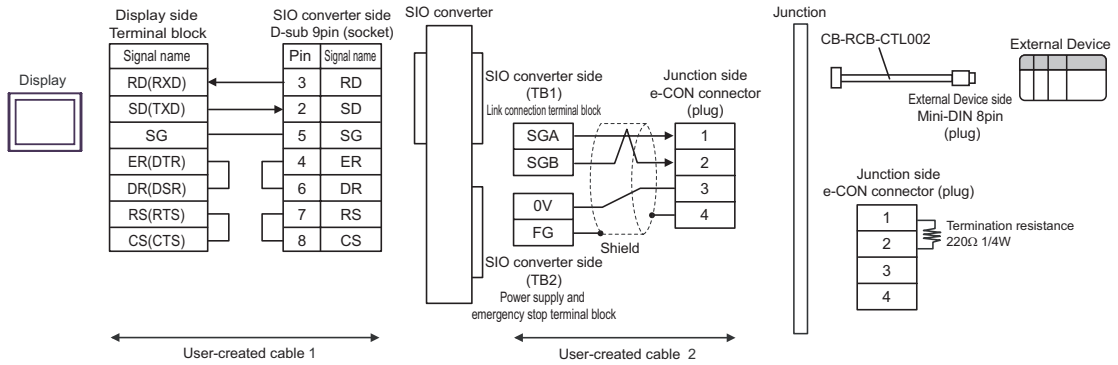

- 1:n connection

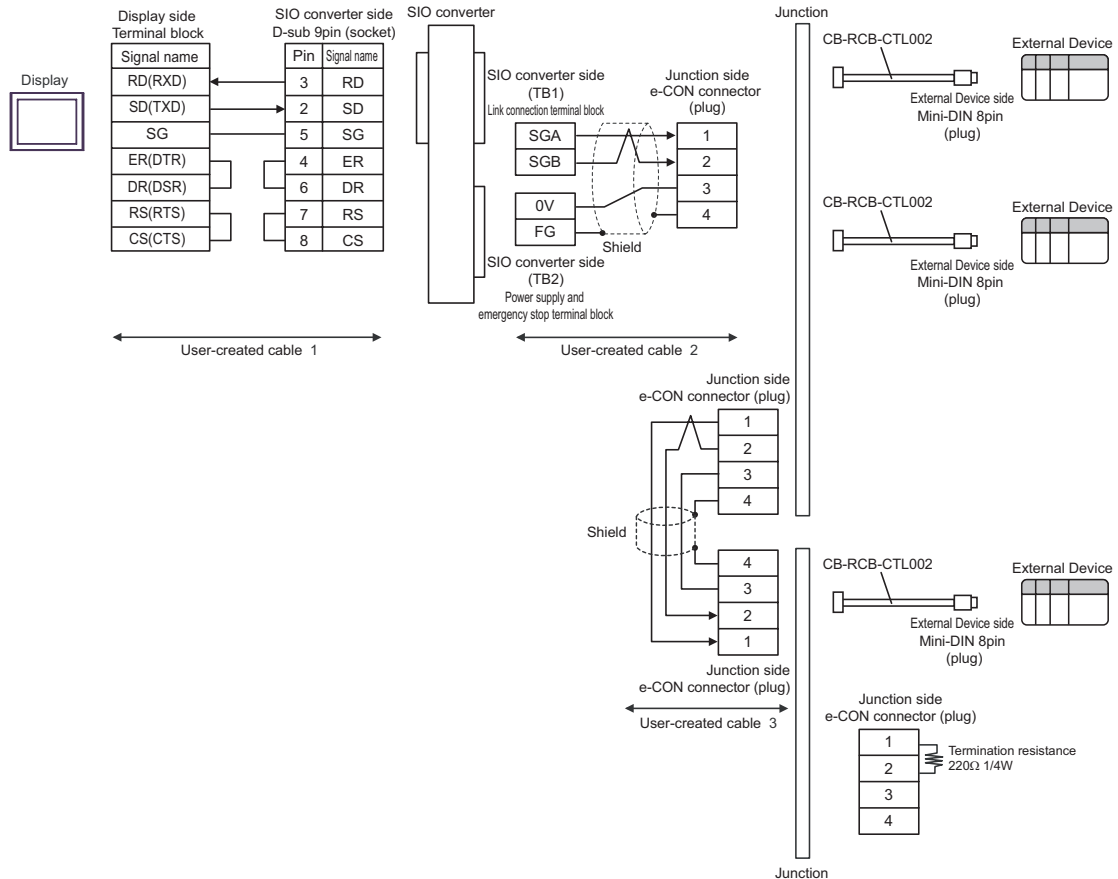

Cable Diagram 4

Display (Connection Port)	Cable		Notes
GP3000 (COM1) ST (COM1) LT (COM1) IPC*1 PC/AT	4A	RS232C conversion unit by IAI Corporation RCB-CV-MW + Communication cable by IAI Corporation CB-RCA-SIO050 + SIO converter by IAI Corporation RC□-TU-SIO-□ + Controller link cable by IAI Corporation CB-RCB-CTL002	Cable length from SIO converter to External Device: 100m or less
	4B	RS232C conversion unit by IAI Corporation RCB-CV-MW + Communication cable by IAI Corporation CB-RCA-SIO050 + SIO converter by IAI Corporation RC□-TU-SIO-□ + User-created cable 1 + Junction by AMP*2 5-1473574-4 + Controller link cable by IAI Corporation CB-RCB-CTL002	
	4C	RS232C conversion unit by IAI Corporation RCB-CV-MW + Communication cable by IAI Corporation CB-RCA-SIO050 + SIO converter by IAI Corporation RC□-TU-SIO-□ + User-created cable 1 + Junction by AMP*2 5-1473574-4 + Controller link cable by IAI Corporation CB-RCB-CTL002	

continued to next page

Display (Connection Port)	Cable		Notes
GP-4105 (COM1)	4D	User-created cable + RS232C conversion unit by IAI Corporation RCB-CV-MW + Communication cable by IAI Corporation CB-RCA-SIO050 + SIO converter by IAI Corporation RC□-TU-SIO-□ + Controller link cable by IAI Corporation CB-RCB-CTL002	Cable length from SIO converter to External Device: 100m or less
	4E	User-created cable + RS232C conversion unit by IAI Corporation RCB-CV-MW + Communication cable by IAI Corporation CB-RCA-SIO050 + SIO converter by IAI Corporation RC□-TU-SIO-□ + User-created cable 1 + Junction by AMP*2 5-1473574-4 + Controller link cable by IAI Corporation CB-RCB-CTL002	
	4F	User-created cable + RS232C conversion unit by IAI Corporation RCB-CV-MW + Communication cable by IAI Corporation CB-RCA-SIO050 + SIO converter by IAI Corporation RC□-TU-SIO-□ + User-created cable 1 + Junction by AMP*2 5-1473574-4 + Controller link cable by IAI Corporation CB-RCB-CTL002	

\*1 Only the COM port which can communicate by RS-232C can be used.

 ■ IPC COM Port (page 5)

\*2 When using more than one junction by AMP, user-created cable 2 is required.

**NOTE**

- RS232C conversion unit (RCB-CV-MW) and communication cable (CB-RCA-SIO050) are accessories of PC Interface Software (RCM-101-MW) by IAI Corporation.
- When connecting to 3 or more External Devices, use a junction by AMP.

4A)

- 1:1 connection

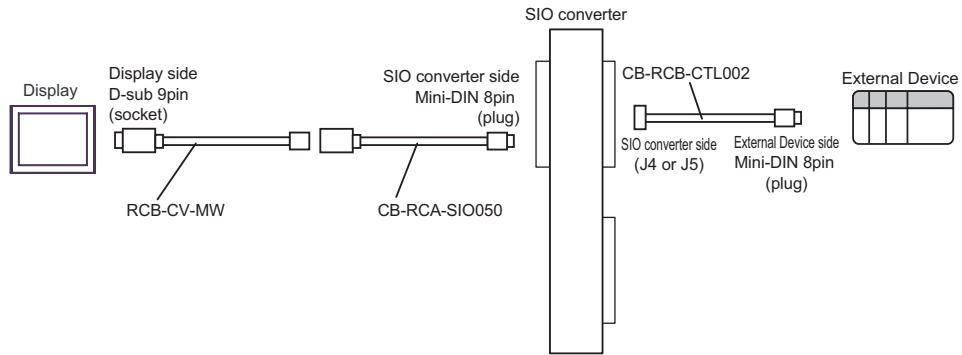

- 1:n connection

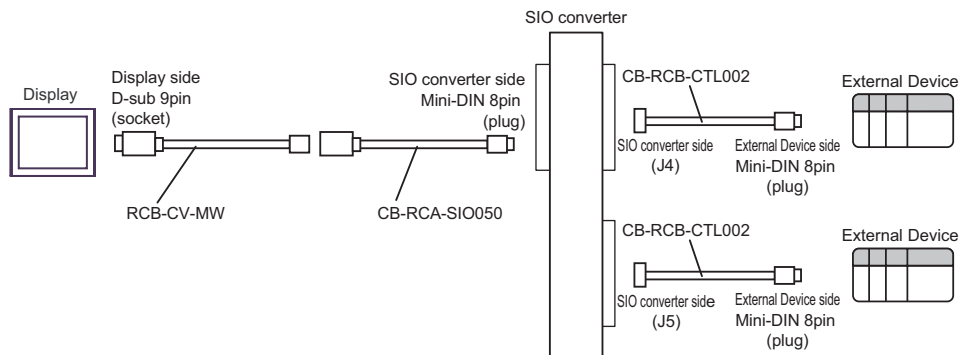

4B)

- 1:1 connection

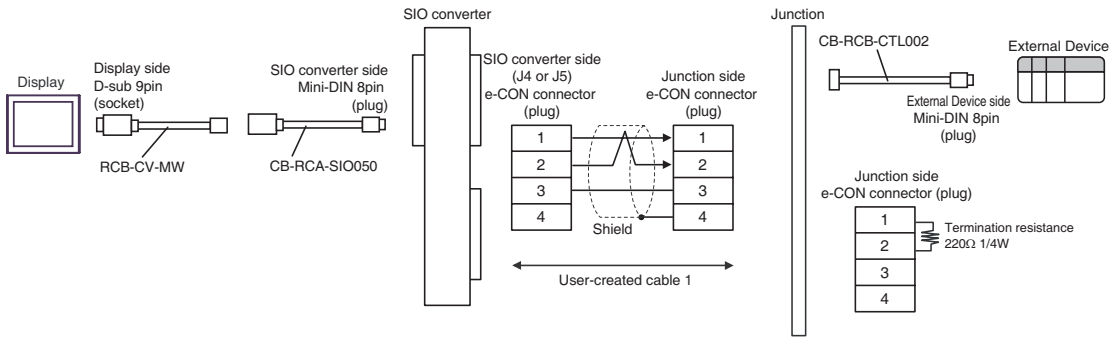

- 1:n connection

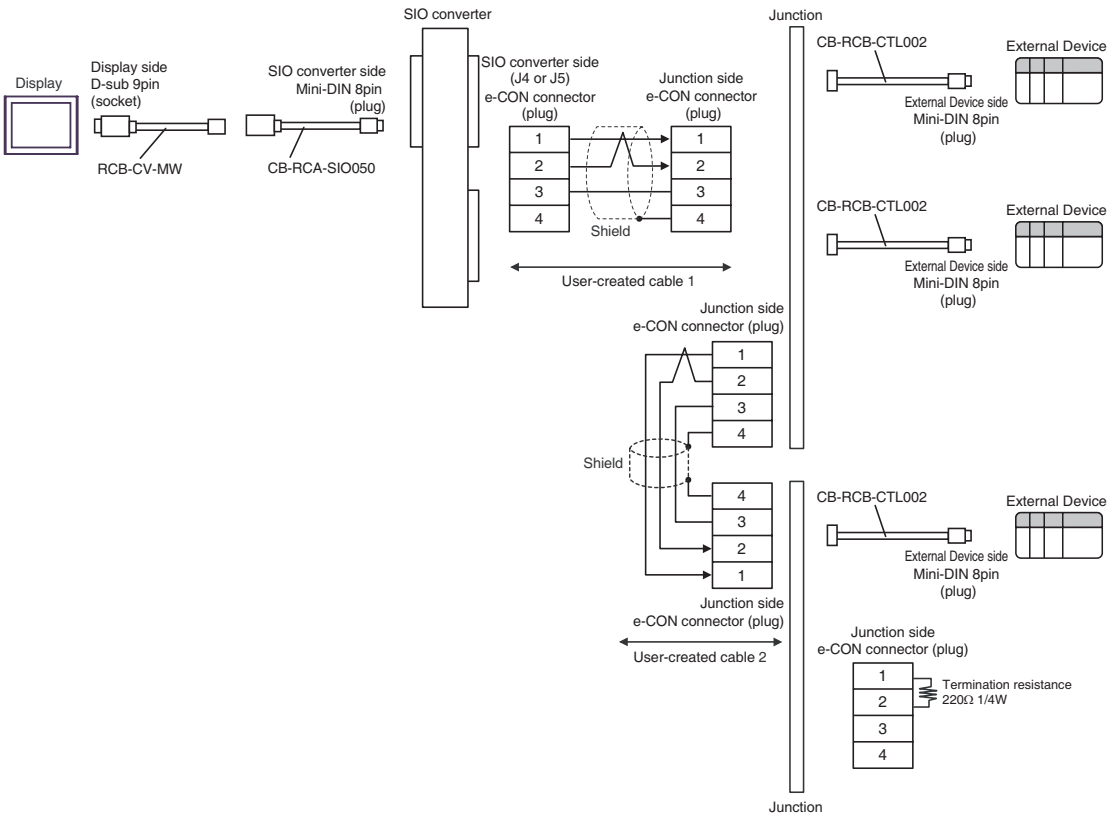



4C)

- 1:1 connection

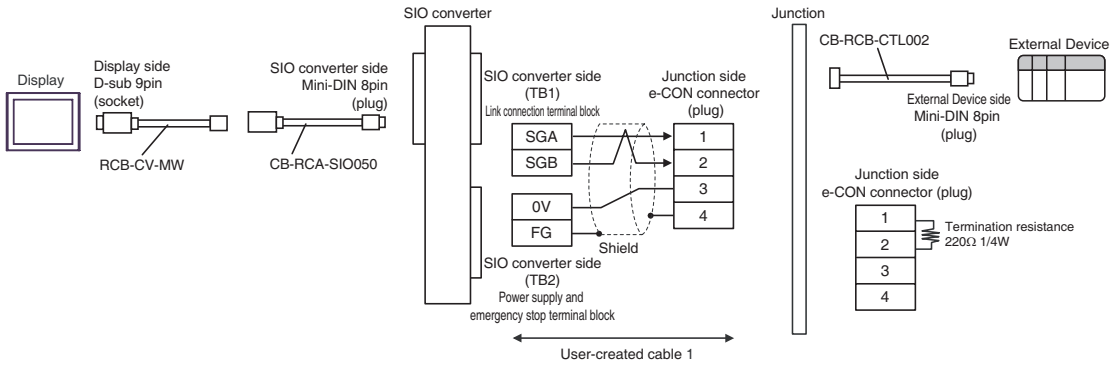

- 1:n connection

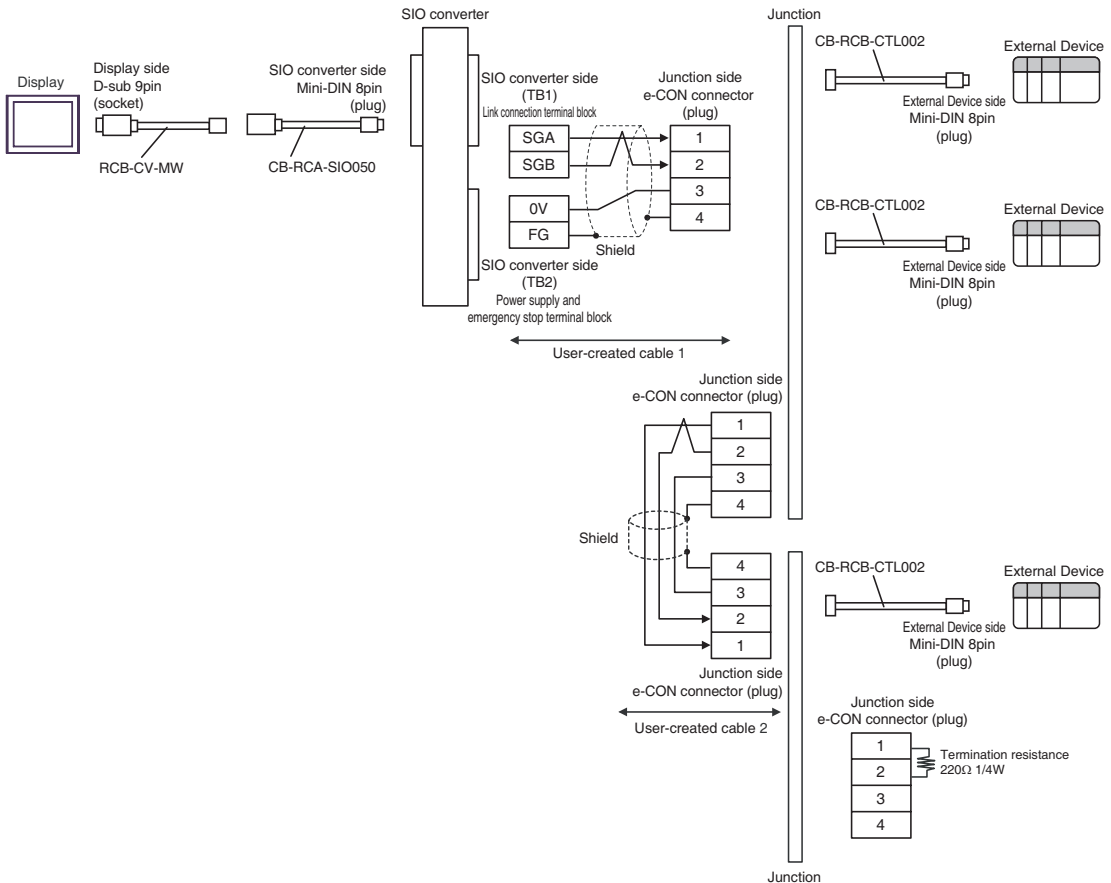

4D)

- 1:1 connection

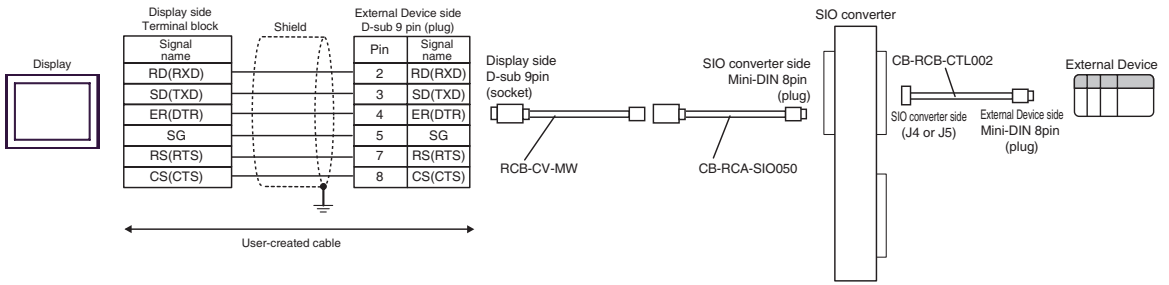

- 1:n connection

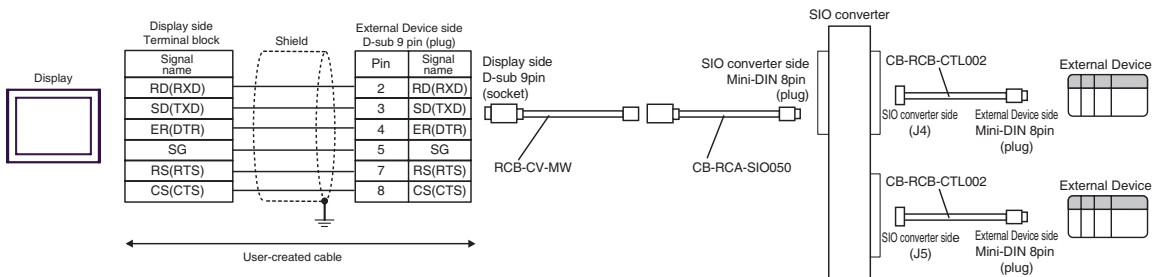

4E)

- 1:1 connection

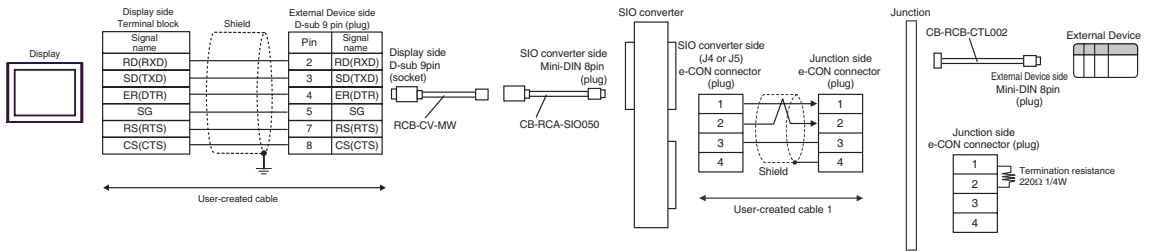

- 1:n connection

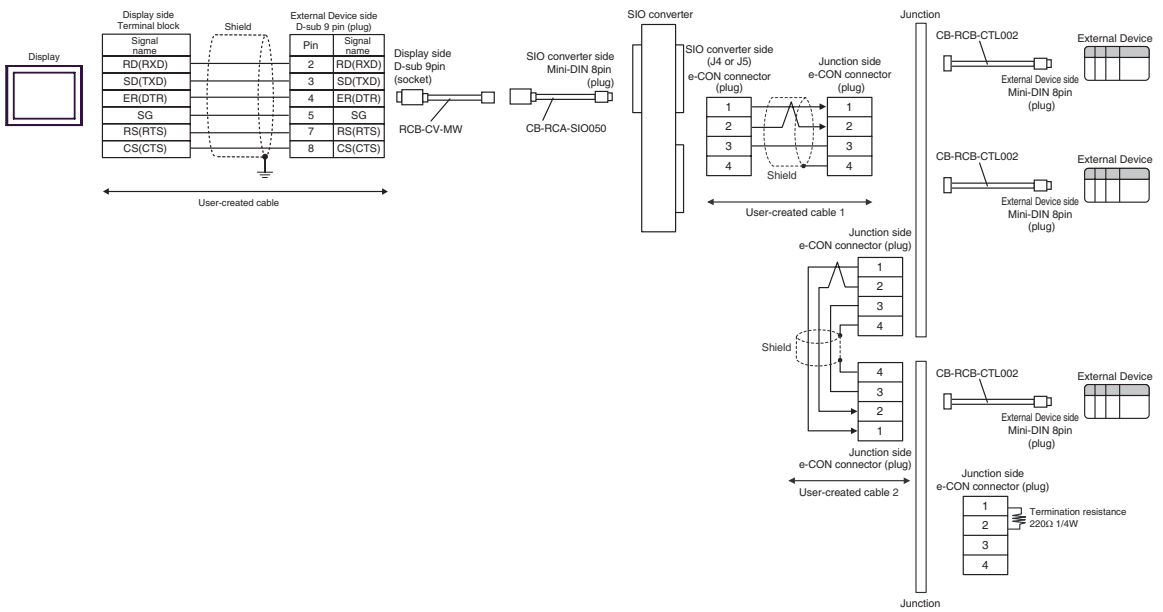

4F)

- 1:1 connection

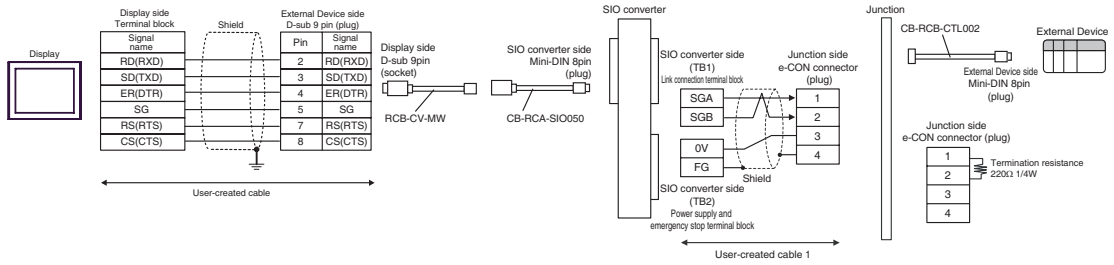

- 1:n connection

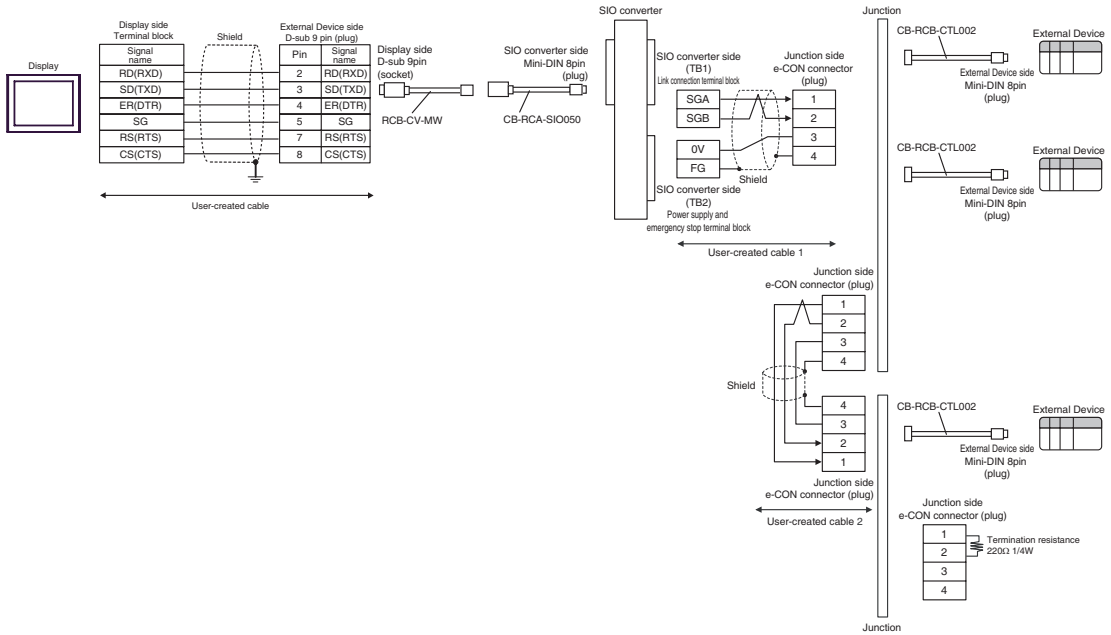

Cable Diagram 5

Display (Connection Port)	Cable		Notes
GP3000* <sup>1</sup> (COM1) AGP-3302B (COM2) ST* <sup>2</sup> (COM2) LT (COM1)	5A	COM port conversion adapter by Pro-face CA3-ADPCOM-01 + Terminal block conversion adapter by Pro-face CA3-ADPTRM-01 + User-created cable + Terminal block + Relay cable by IAI Corporation CB-ERC-PWBIO□□□ or CB-ERC-PWBIO□□□-RB	Cable length: 100m or less
	5B	User-created cable + Terminal block + Relay cable by IAI Corporation CB-ERC-PWBIO□□□ or CB-ERC-PWBIO□□□-RB	
GP3000* <sup>3</sup> (COM2)	5C	Online adapter by Pro-face CA4-ADPONL-01 + Terminal block conversion adapter by Pro-face CA3-ADPTRM-01 + User-created cable + Terminal block + Relay cable by IAI Corporation CB-ERC-PWBIO□□□ or CB-ERC-PWBIO□□□-RB	
	5D	Online adapter by Pro-face CA4-ADPONL-01 + User-created cable + Terminal block + Relay cable by IAI Corporation CB-ERC-PWBIO□□□ or CB-ERC-PWBIO□□□-RB	

continued to next page

Display (Connection Port)	Cable		Notes
IPC*4	5E	COM port conversion adapter by Pro-face CA3-ADPCOM-01 + Terminal block conversion adapter by Pro-face CA3-ADPTRM-01 + User-created cable + Terminal block + Relay cable by IAI Corporation CB-ERC-PWBIO□□□ or CB-ERC-PWBIO□□□-RB	Cable length: 100m or less
	5F	User-created cable + Terminal block + Relay cable by IAI Corporation CB-ERC-PWBIO□□□ or CB-ERC-PWBIO□□□-RB	
GP-4106 (COM1)	5G	User-created cable + Terminal block + Relay cable by IAI Corporation CB-ERC-PWBIO□□□ or CB-ERC-PWBIO□□□-RB	
GP-4107 (COM1)	5H	User-created cable + Terminal block + Relay cable by IAI Corporation CB-ERC-PWBIO□□□ or CB-ERC-PWBIO□□□-RB	

\*1 All GP3000 models except AGP-3302B

\*2 All ST models except AST-3211A and AST-3302B

\*3 All GP3000 models except GP-3200 series and AGP-3302B

\*4 Only the COM port which can communicate by RS-422/485 (2 wire) can be used.

 ■ IPC COM Port (page 5)

5A)

- 1:1 connection

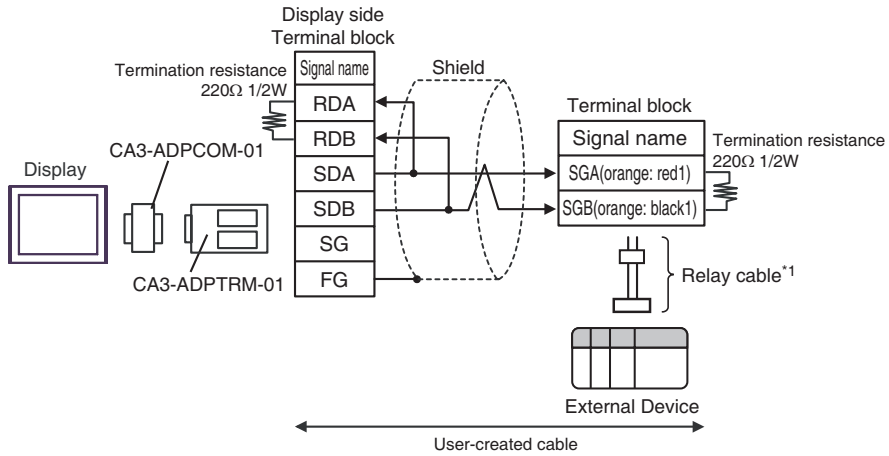

\*1 We recommend the IAI Corporation CB-ERC-PWBIO□□□□ or CB-ERC-PWBIO□□□□-RB as the relay cable.

- 1:n connection

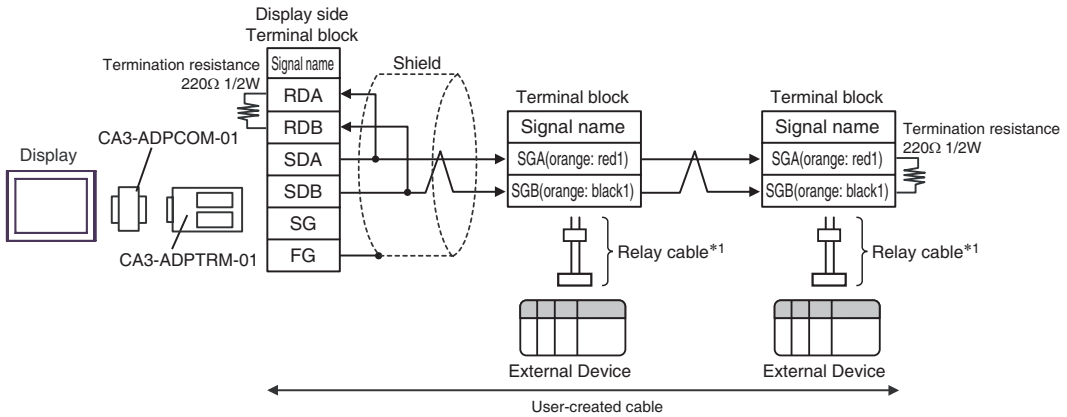

\*1 We recommend the IAI Corporation CB-ERC-PWBIO□□□□ or CB-ERC-PWBIO□□□□-RB as the relay cable.

5B)

- 1:1 connection

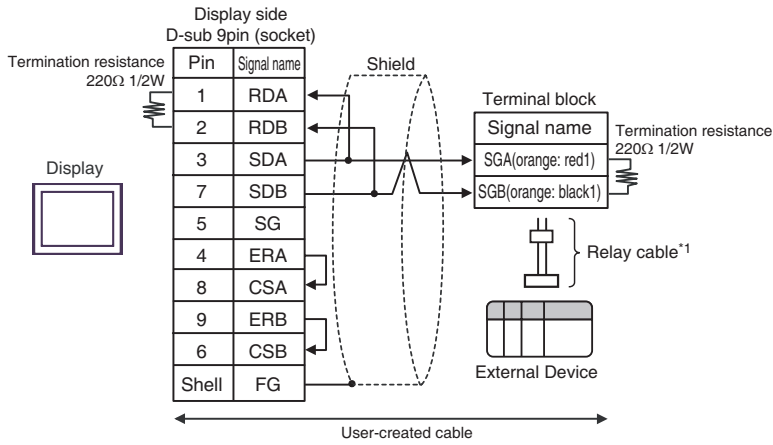

\*1 We recommend the IAI Corporation CB-ERC-PWBIO□□□□ or CB-ERC-PWBIO□□□□-RB as the relay cable.

- 1:n connection

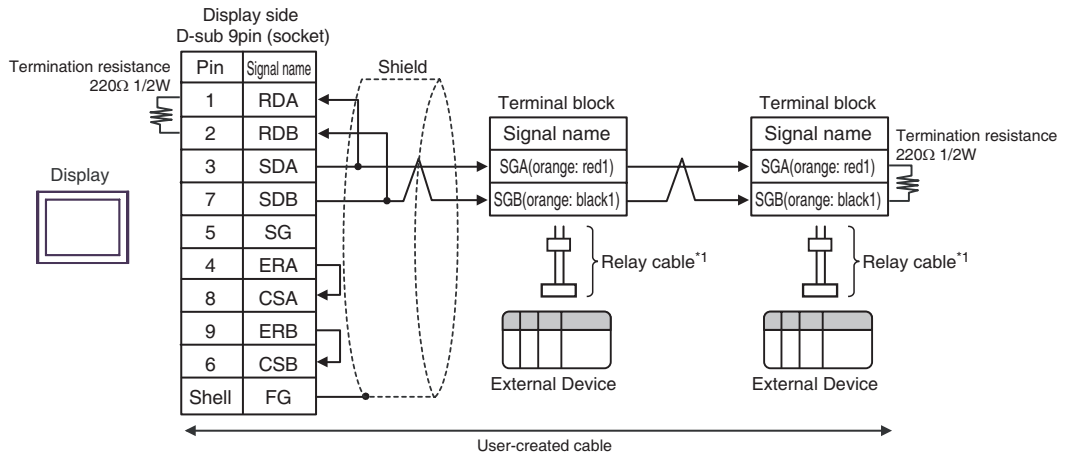

\*1 We recommend the IAI Corporation CB-ERC-PWBIO□□□□ or CB-ERC-PWBIO□□□□-RB as the relay cable.



5C)

- 1:1 connection

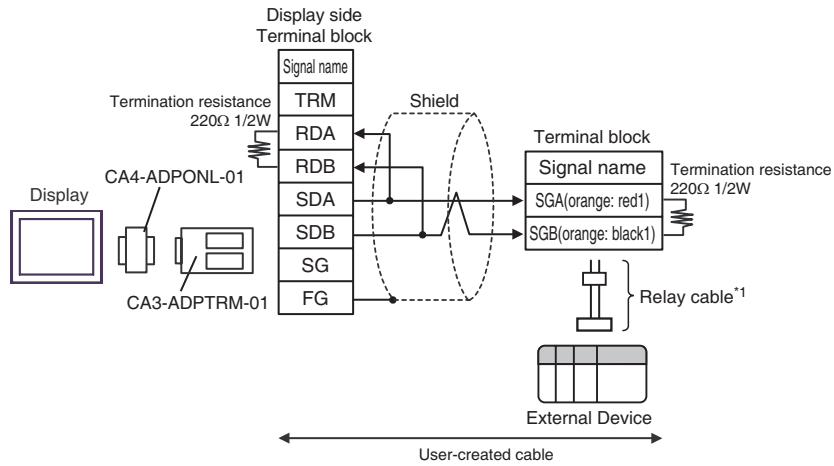

\*1 We recommend the IAI Corporation CB-ERC-PWBIO□□□□ or CB-ERC-PWBIO□□□□-RB as the relay cable.

- 1:n connection

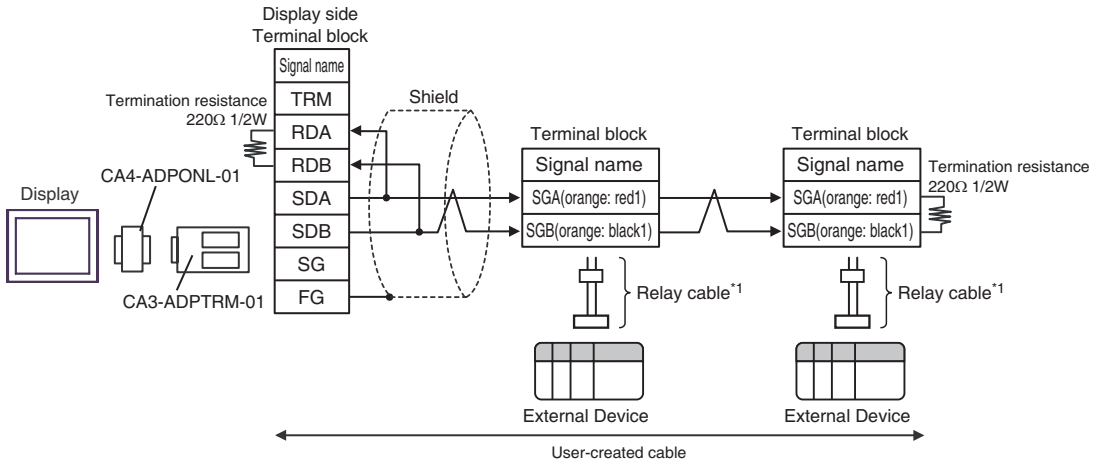

\*1 We recommend the IAI Corporation CB-ERC-PWBIO□□□□ or CB-ERC-PWBIO□□□□-RB as the relay cable.

5D)

- 1:1 connection

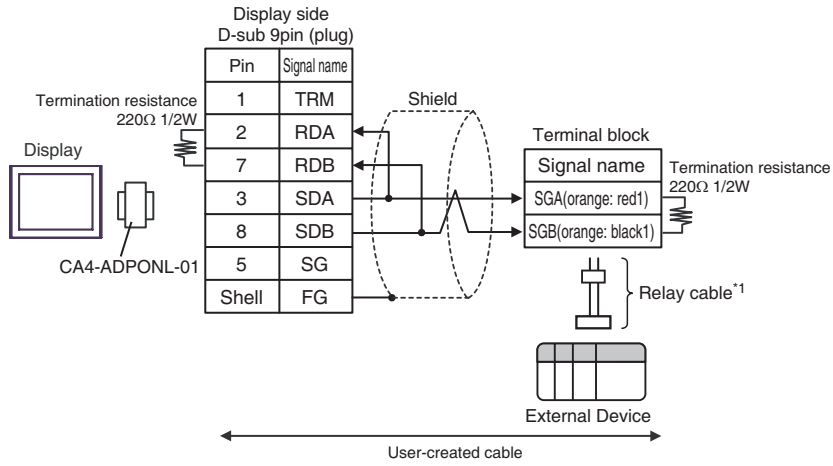

\*1 We recommend the IAI Corporation CB-ERC-PWBIO□□□ or CB-ERC-PWBIO□□□-RB as the relay cable.

- 1:n connection

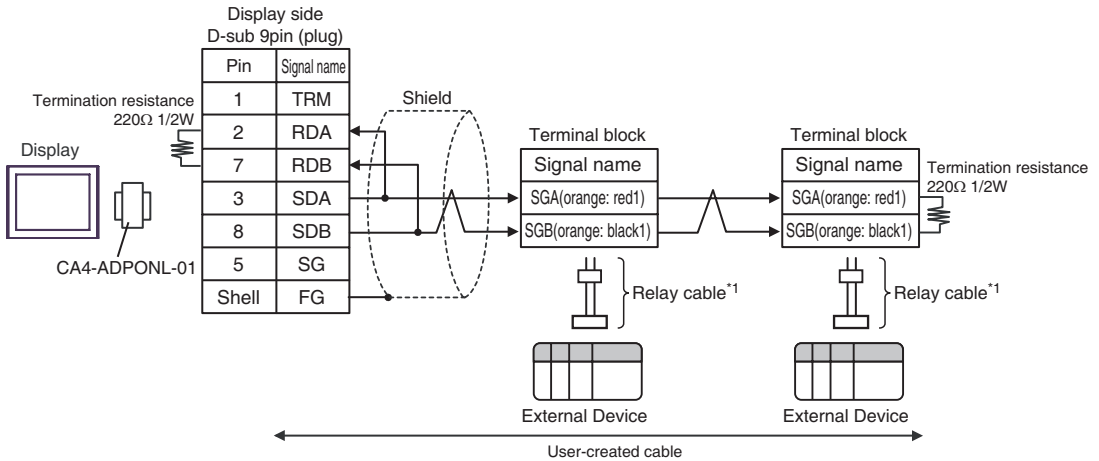

\*1 We recommend the IAI Corporation CB-ERC-PWBIO□□□ or CB-ERC-PWBIO□□□-RB as the relay cable.

5E)

- 1:1 connection

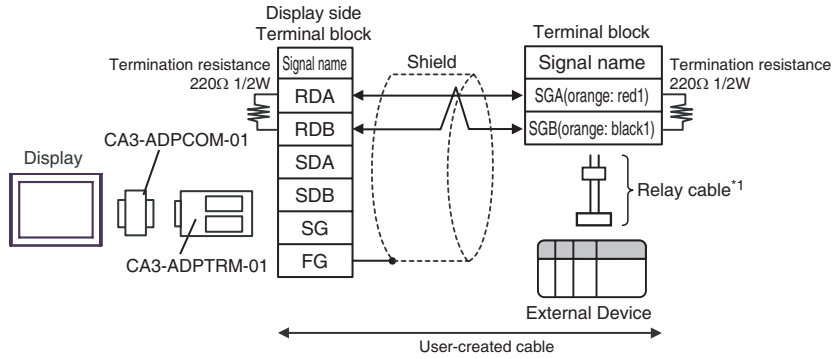

\*1 We recommend the IAI Corporation CB-ERC-PWBIO□□□□ or CB-ERC-PWBIO□□□□-RB as the relay cable.

- 1:n connection

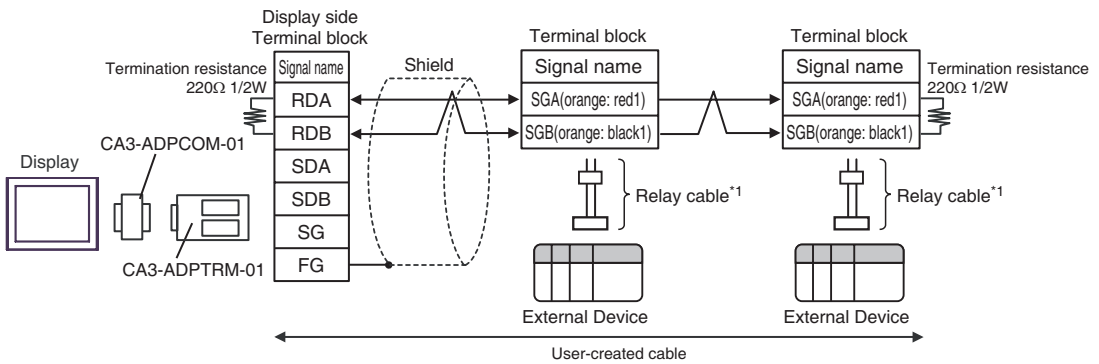

\*1 We recommend the IAI Corporation CB-ERC-PWBIO□□□□ or CB-ERC-PWBIO□□□□-RB as the relay cable.

5F)

- 1:1 connection

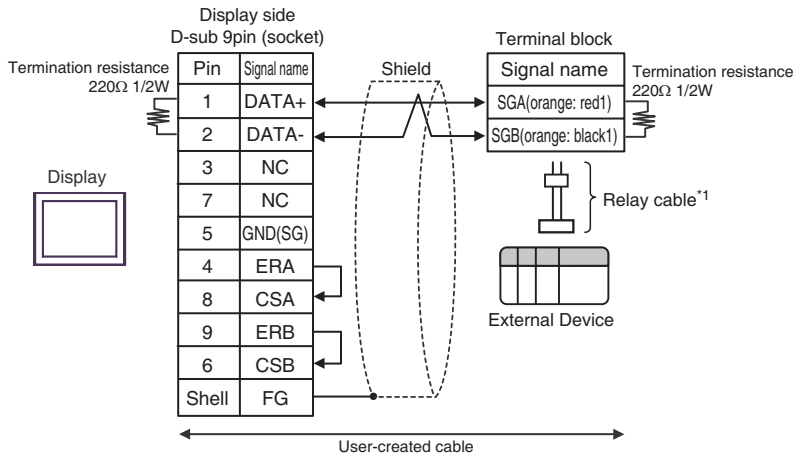

\*1 We recommend the IAI Corporation CB-ERC-PWBIO□□□ or CB-ERC-PWBIO□□□-RB as the relay cable.

- 1:n connection

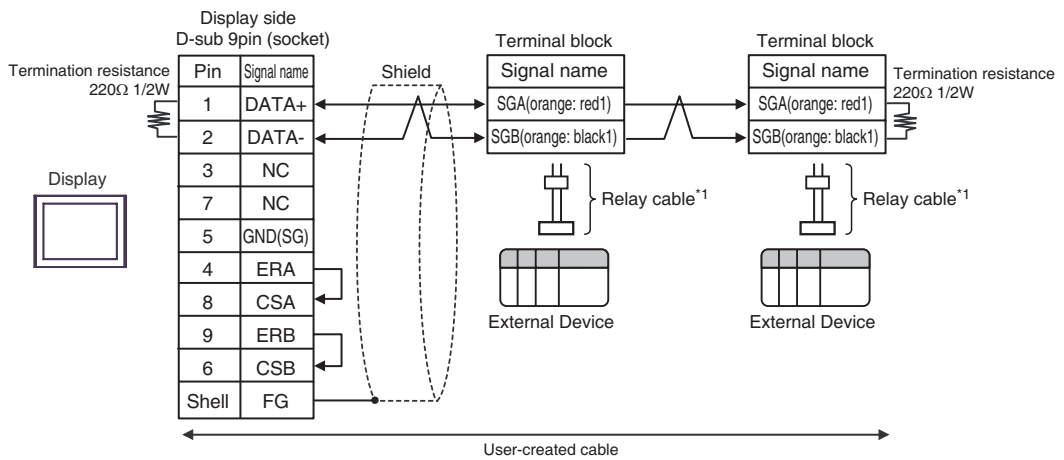

\*1 We recommend the IAI Corporation CB-ERC-PWBIO□□□ or CB-ERC-PWBIO□□□-RB as the relay cable.

5G)

- 1:1 connection

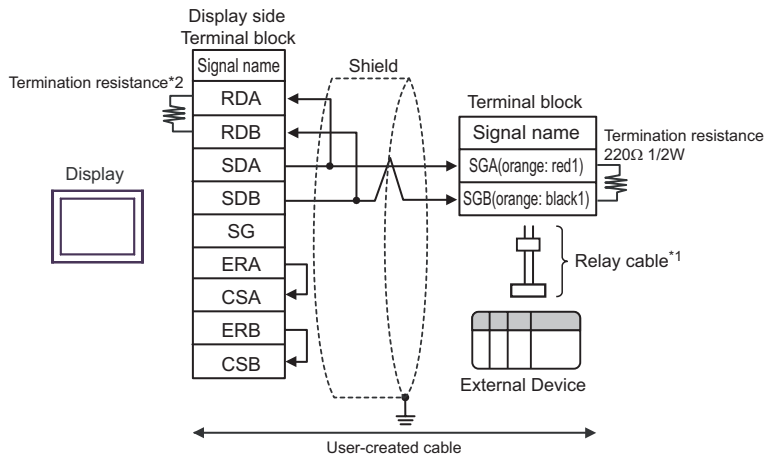

\*1 We recommend the IAI Corporation CB-ERC-PWBIO□□□□ or CB-ERC-PWBIO□□□□-RB as the relay cable.

\*2 The resistance in the Display is used as the termination resistance. Set the value of the DIP Switch on the rear of the Display as shown in the table below.

DIP Switch No.	Set Value
1	OFF
2	OFF
3	OFF
4	ON

- 1:n connection

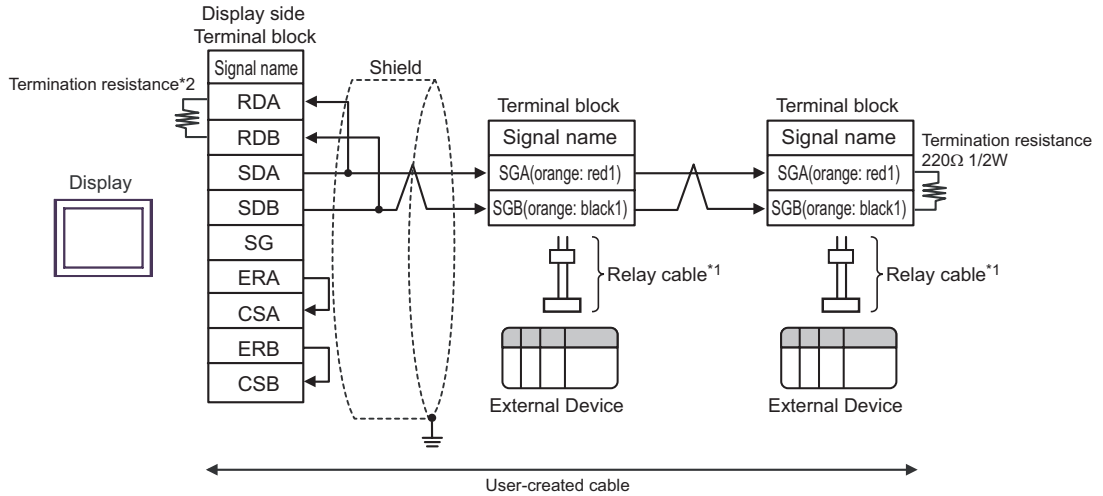

- \*1 We recommend the IAI Corporation CB-ERC-PWBIO□□□□ or CB-ERC-PWBIO□□□□-RB as the relay cable.
- \*2 The resistance in the Display is used as the termination resistance. Set the value of the DIP Switch on the rear of the Display as shown in the table below.

DIP Switch No.	Set Value
1	OFF
2	OFF
3	OFF
4	ON

5H)

- 1:1 connection

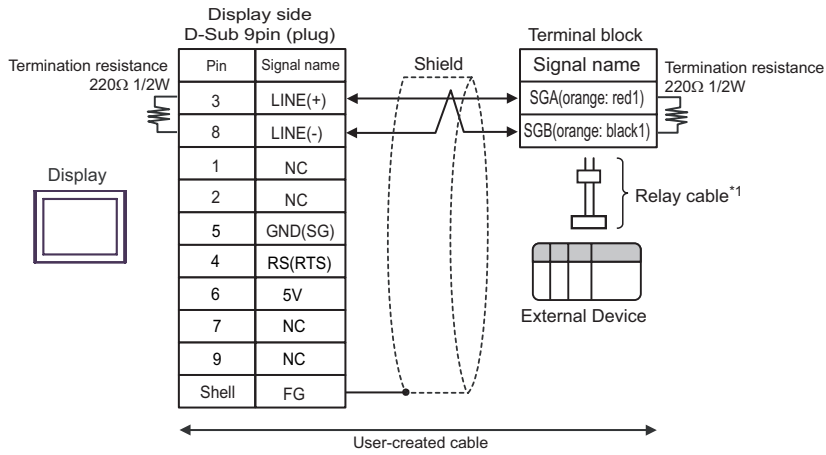

\*1 We recommend the IAI Corporation CB-ERC-PWBIO□□□□ or CB-ERC-PWBIO□□□□-RB as the relay cable.

- 1:n connection

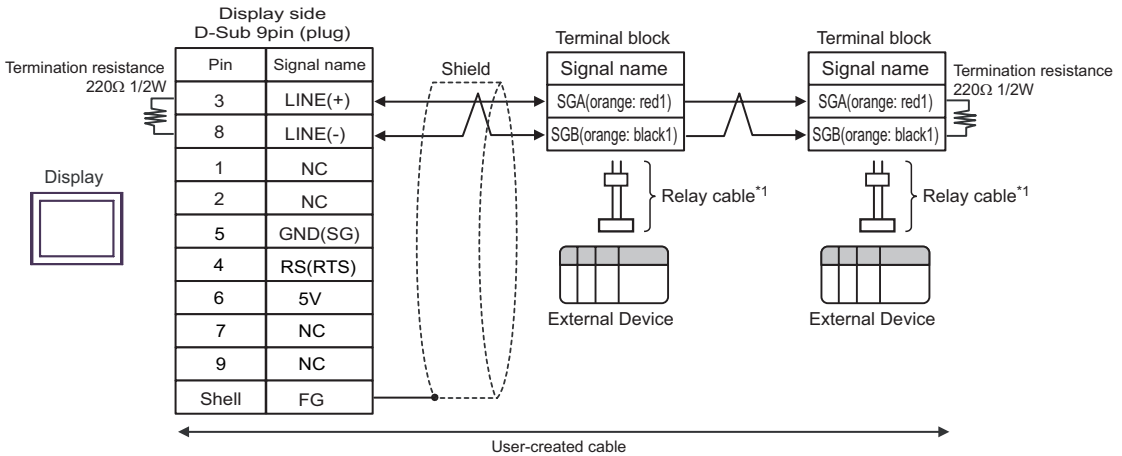

\*1 We recommend the IAI Corporation CB-ERC-PWBIO□□□□ or CB-ERC-PWBIO□□□□-RB as the relay cable.

**IMPORTANT**

- The 5V output (Pin #6) on the GP-4107 is the power for the Siemens AG's PROFIBUS connector. Do not use it for other devices.

**NOTE**

- In COM on the GP-4107, the SG and FG terminals are isolated.

Cable Diagram 6

Display (Connection Port)	Cable		Notes
GP3000 (COM1) ST (COM1) LT (COM1) IPC*1 PC/AT	6A	User-created cable 1 + SIO converter by IAI Corporation RC□-TU-SIO-□ + User-created cable 2 + Terminal block + Relay cable by IAI Corporation CB-ERC-PWBIO□□□ or CB-ERC-PWBIO□□□-RB	Cable length from Display to SIO converter: 15m or less  Cable length from SIO converter to External Device: 100m or less
	6B	User-created cable 1 + SIO converter by IAI Corporation RC□-TU-SIO-□ + User-created cable 2 + Relay cable by IAI Corporation CB-ERC-PWBIO□□□ or CB-ERC-PWBIO□□□-RB	
	6C	User-created cable 1 + SIO converter by IAI Corporation RC□-TU-SIO-□ + User-created cable 2 + Junction by AMP*2 5-1473574-4 + User-created cable 3 + Terminal block + Relay cable by IAI Corporation CB-ERC-PWBIO□□□ or CB-ERC-PWBIO□□□-RB	

continued to next page



Display (Connection Port)	Cable		Notes
GP3000 (COM1) ST (COM1) LT (COM1) IPC*1 PC/AT	6D	User-created cable 1 + SIO converter by IAI Corporation RC□-TU-SIO-□ + User-created cable 2 + Junction by AMP*2 5-1473574-4 + User-created cable 3 + Terminal block + Relay cable by IAI Corporation CB-ERC-PWBIO□□□ or CB-ERC-PWBIO□□□-RB	Cable length from Display to SIO converter: 15m or less  Cable length from SIO converter to External Device: 100m or less
	6E	User-created cable 1 + SIO converter by IAI Corporation RC□-TU-SIO-□ + User-created cable 2 + Insulated PIO terminal block by IAI Corporation RC□-TU-PIO-□ + Relay cable by IAI Corporation CB-ERC-PWBIO□□□-H6 or CB-ERC-PWBIO□□□-RB-H6	
GP-4105 (COM1)	6F	User-created cable 1 + SIO converter by IAI Corporation RC□-TU-SIO-□ + User-created cable 2 + Terminal block + Relay cable by IAI Corporation CB-ERC-PWBIO□□□ or CB-ERC-PWBIO□□□-RB	
	6G	User-created cable 1 + SIO converter by IAI Corporation RC□-TU-SIO-□ + User-created cable 2 + Relay cable by IAI Corporation CB-ERC-PWBIO□□□ or CB-ERC-PWBIO□□□-RB	

Display (Connection Port)	Cable		Notes
GP-4105 (COM1)	6H	User-created cable 1 + SIO converter by IAI Corporation RC□-TU-SIO-□ + User-created cable 2 + Junction by AMP*2 5-1473574-4 + User-created cable 3 + Terminal block + Relay cable by IAI Corporation CB-ERC-PWBIO□□□ or CB-ERC-PWBIO□□□-RB	Cable length from Display to SIO converter: 15m or less  Cable length from SIO converter to External Device: 100m or less
	6I	User-created cable 1 + SIO converter by IAI Corporation RC□-TU-SIO-□ + User-created cable 2 + Junction by AMP*2 5-1473574-4 + User-created cable 3 + Terminal block + Relay cable by IAI Corporation CB-ERC-PWBIO□□□ or CB-ERC-PWBIO□□□-RB	
	6J	User-created cable 1 + SIO converter by IAI Corporation RC□-TU-SIO-□ + User-created cable 2 + Insulated PIO terminal block by IAI Corporation RC□-TU-PIO-□ + Relay cable by IAI Corporation CB-ERC-PWBIO□□□-H6 or CB-ERC-PWBIO□□□-RB-H6	

\*1 Only the COM port which can communicate by RS-232C can be used.

 ■ IPC COM Port (page 5)

\*2 When using more than one junction by AMP, user-created cable 4 is required.

**NOTE**

- When connecting to 3 or more External Devices, use link connection terminal block or junction by AMP.

6A)

- 1:1 connection

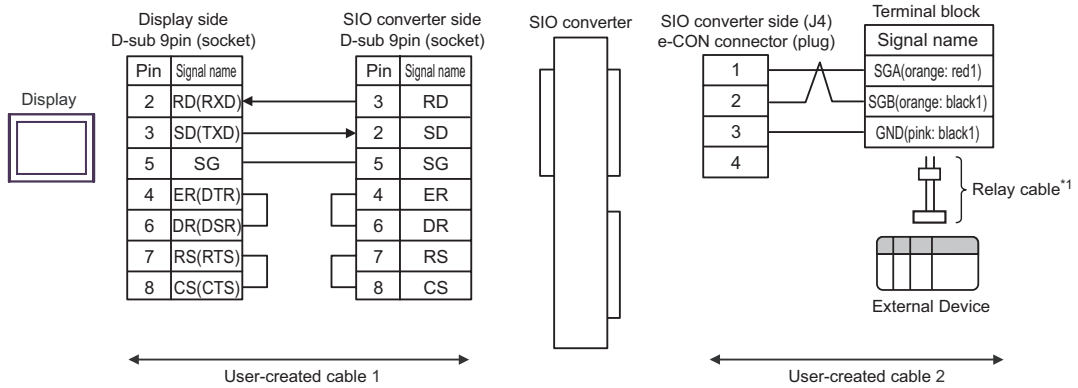

\*1 We recommend the IAI Corporation CB-ERC-PWBIO□□□□ or CB-ERC-PWBIO□□□□-RB as the relay cable.

- 1:n connection

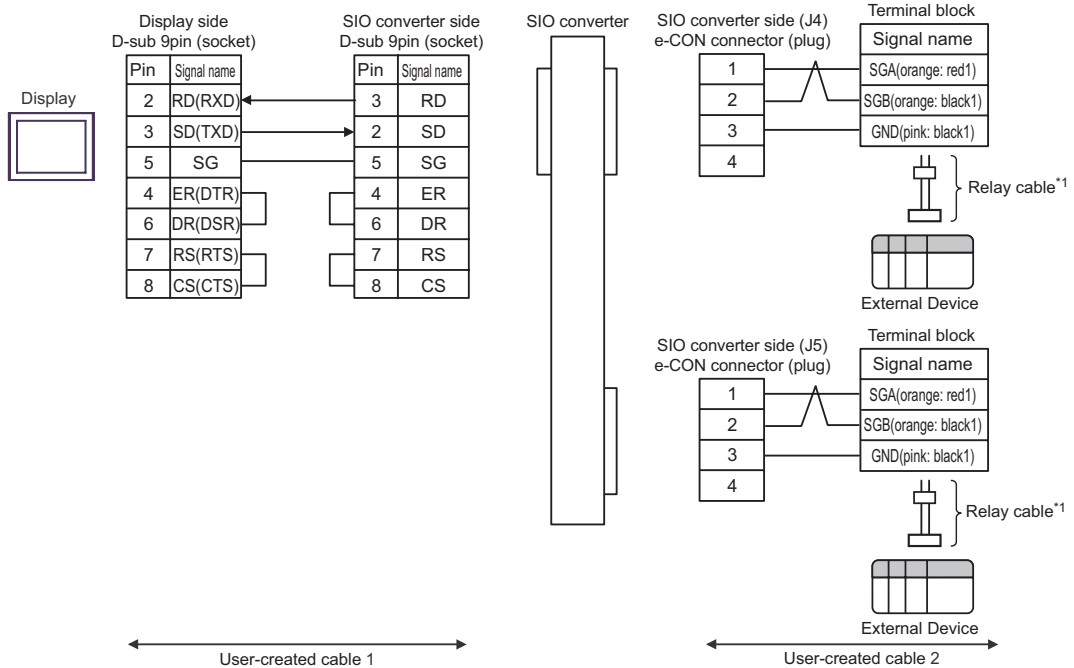

\*1 We recommend the IAI Corporation CB-ERC-PWBIO□□□□ or CB-ERC-PWBIO□□□□-RB as the relay cable.

6B)

- 1:1 connection

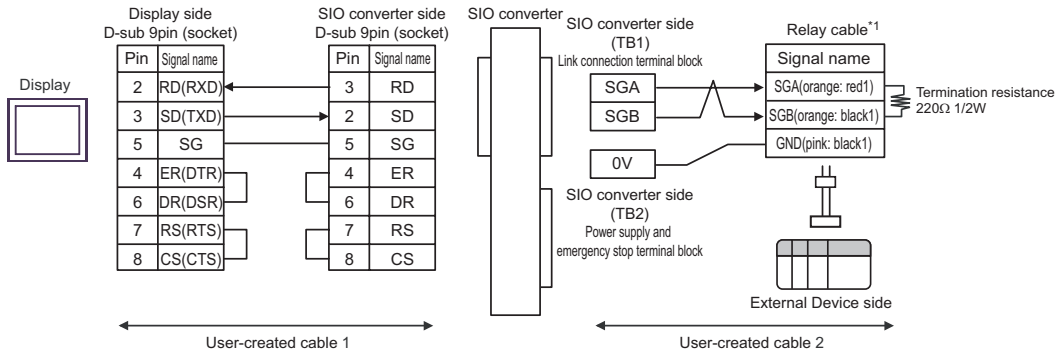

\*1 We recommend the IAI Corporation CB-ERC-PWBIO□□□□ or CB-ERC-PWBIO□□□□-RB as the relay cable.

- 1:n connection

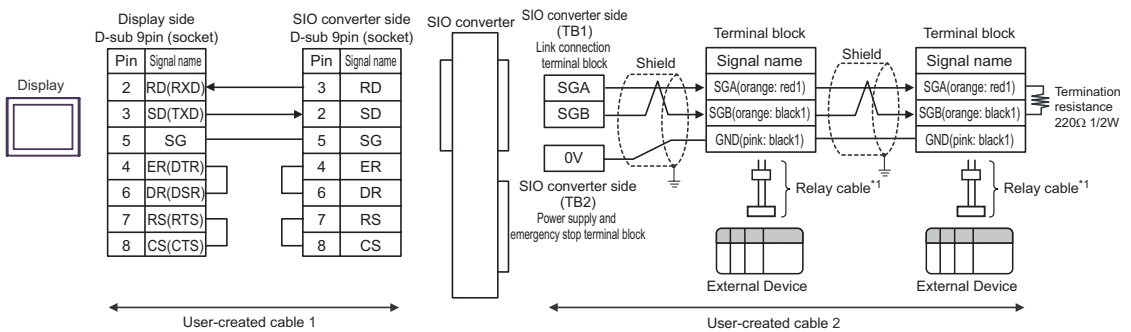

\*1 We recommend the IAI Corporation CB-ERC-PWBIO□□□□ or CB-ERC-PWBIO□□□□-RB as the relay cable.

**NOTE**

- When connecting to more than one equipment, connect the terminal block.

6C)

- 1:1 connection

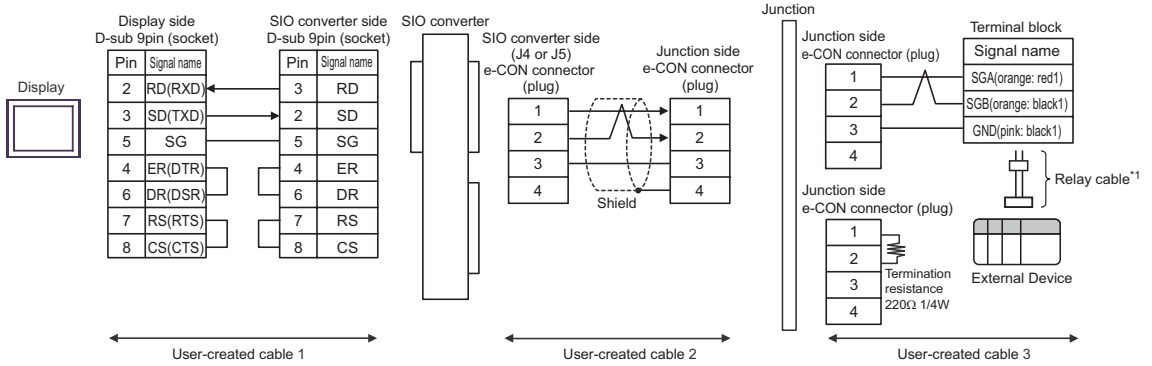

\*1 We recommend the IAI Corporation CB-ERC-PWBIO□□□□ or CB-ERC-PWBIO□□□□-RB as the relay cable.

• 1:n connection

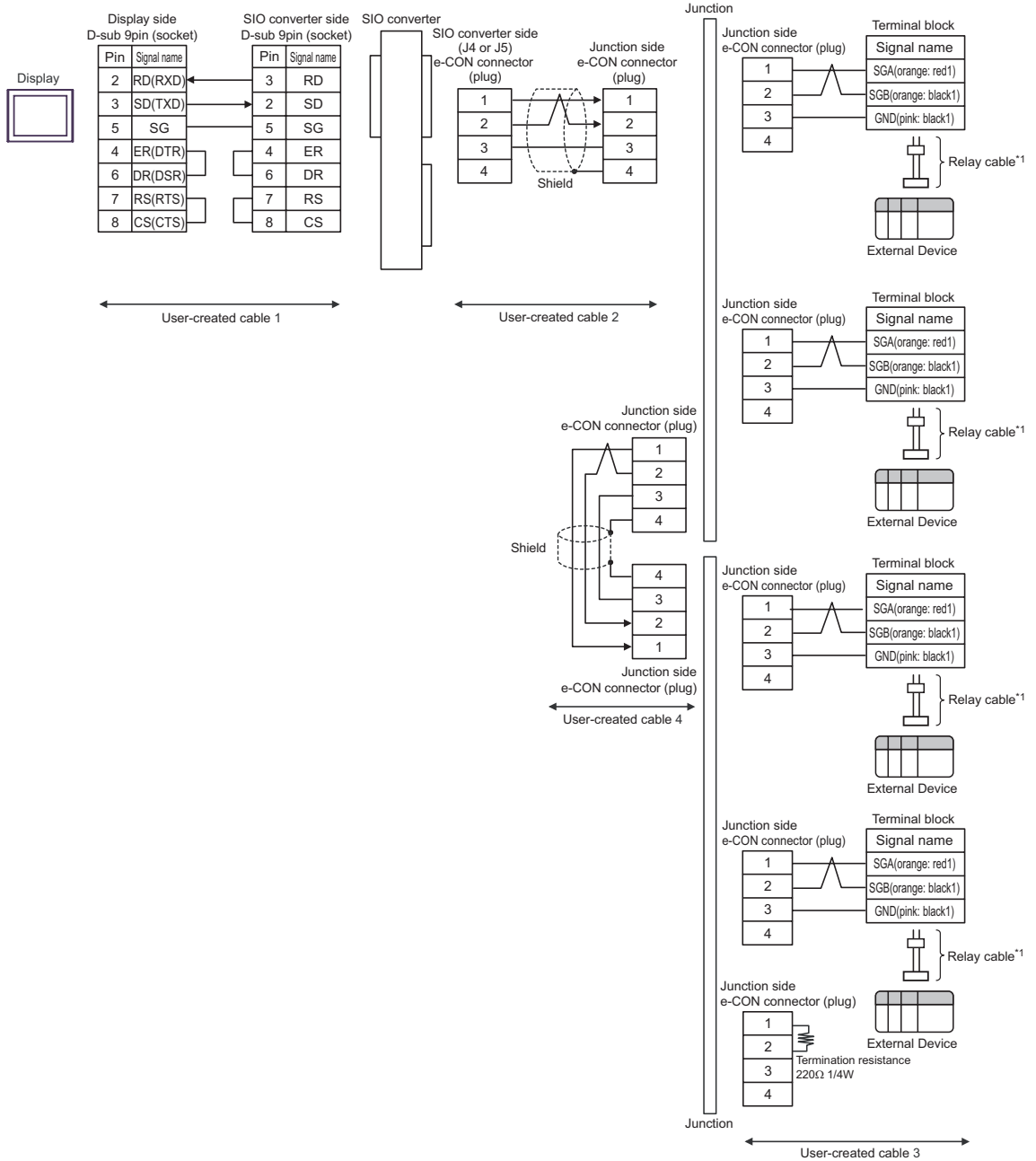

\*1 We recommend the IAI Corporation CB-ERC-PWBIO□□□□ or CB-ERC-PWBIO□□□□-RB as the relay cable.

6D)

- 1:1 connection

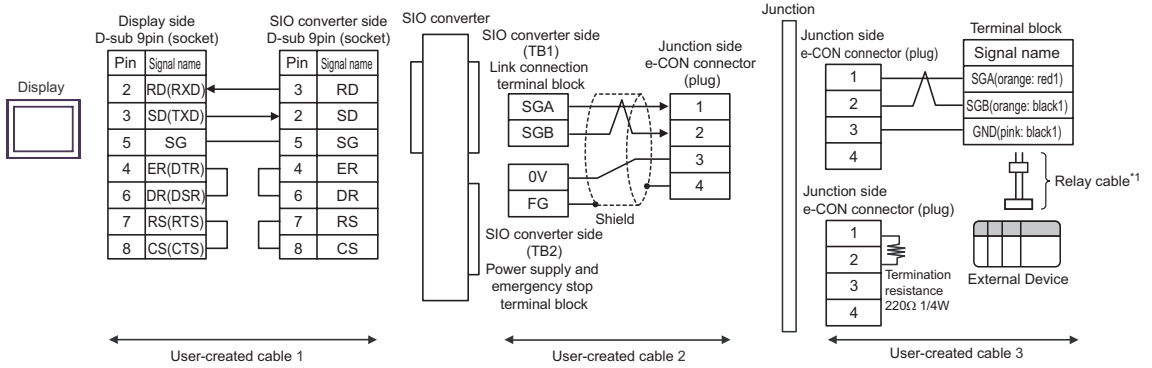

\*1 We recommend the IAI Corporation CB-ERC-PWBIO□□□ or CB-ERC-PWBIO□□□-RB as the relay cable.

• 1:n connection

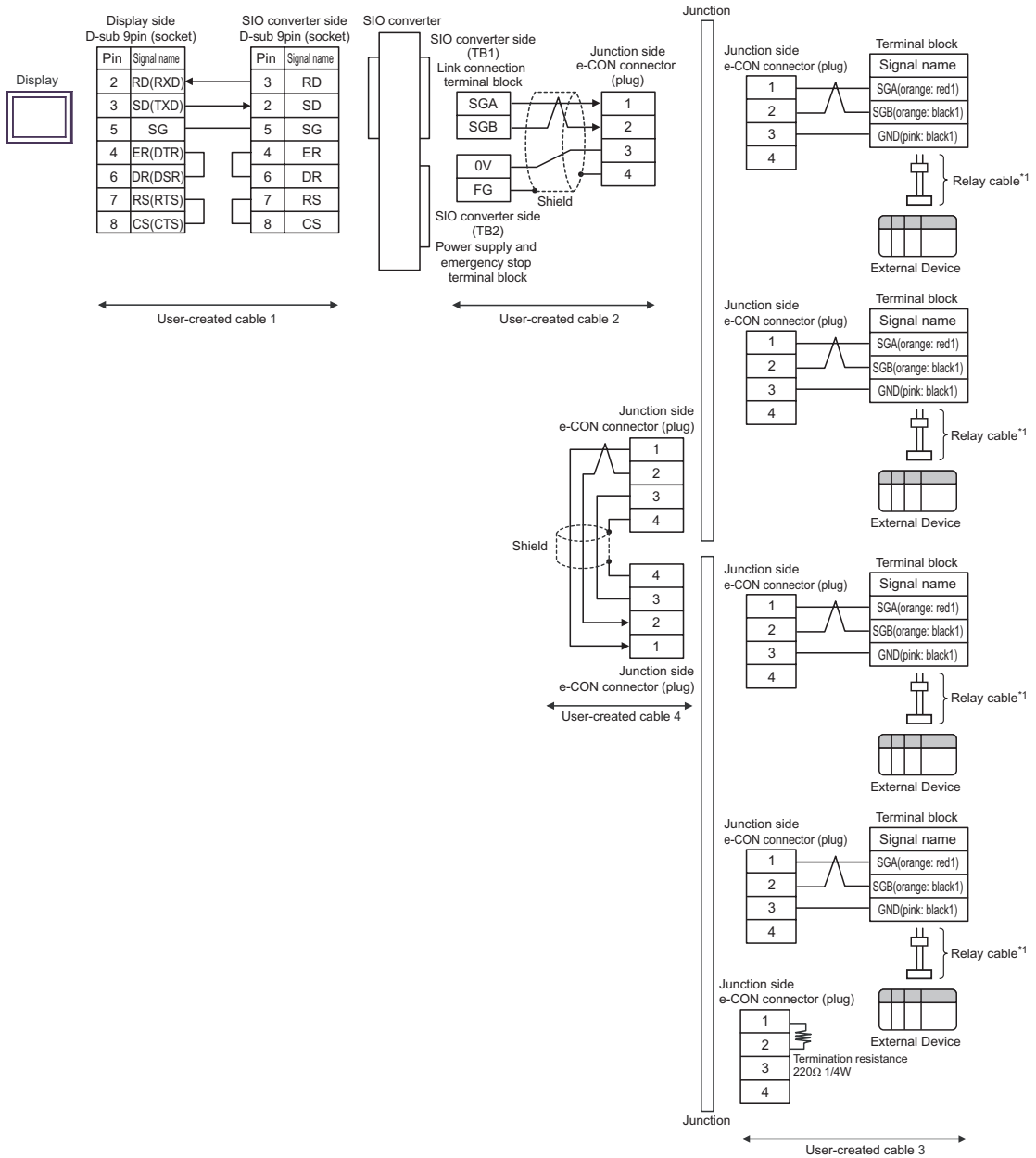

\*1 We recommend the IAI Corporation CB-ERC-PWBIO□□□□ or CB-ERC-PWBIO□□□□-RB as the relay cable.



6E)

- 1:1 connection

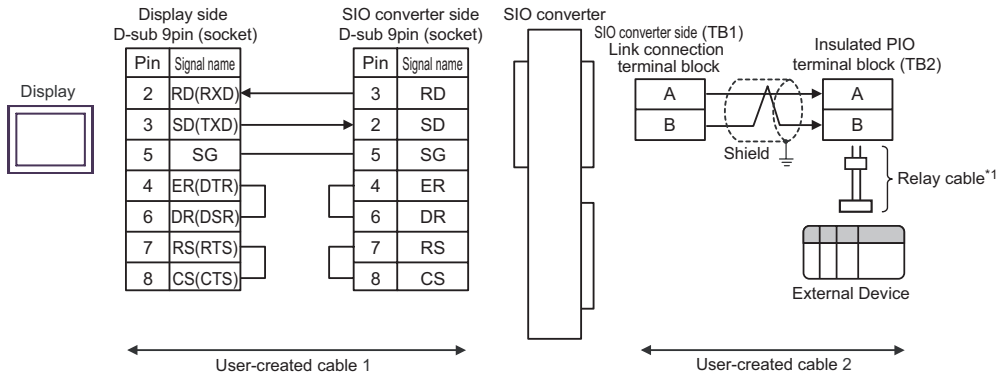

\*1 We recommend the IAI Corporation CB-ERC-PWBIO□□□-H6 or CB-ERC-PWBIO□□□-RB-H6 as the relay cable.

- 1:n connection

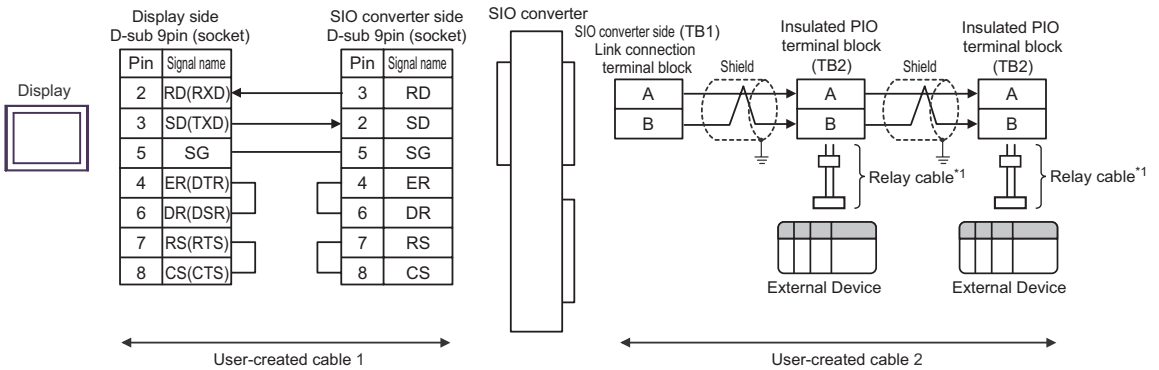

\*1 We recommend the IAI Corporation CB-ERC-PWBIO□□□-H6 or CB-ERC-PWBIO□□□-RB-H6 as the relay cable.

**NOTE**

- Set the termination resistance connection switch of the PIO terminal block on the end to RTON side.

6F)

- 1:1 connection

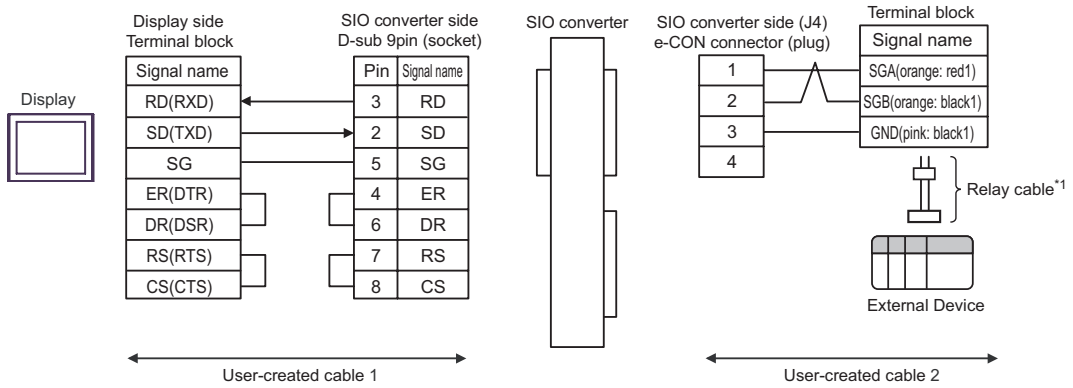

\*1 We recommend the IAI Corporation CB-ERC-PWBIO□□□□ or CB-ERC-PWBIO□□□□-RB as the relay cable.

- 1:n connection

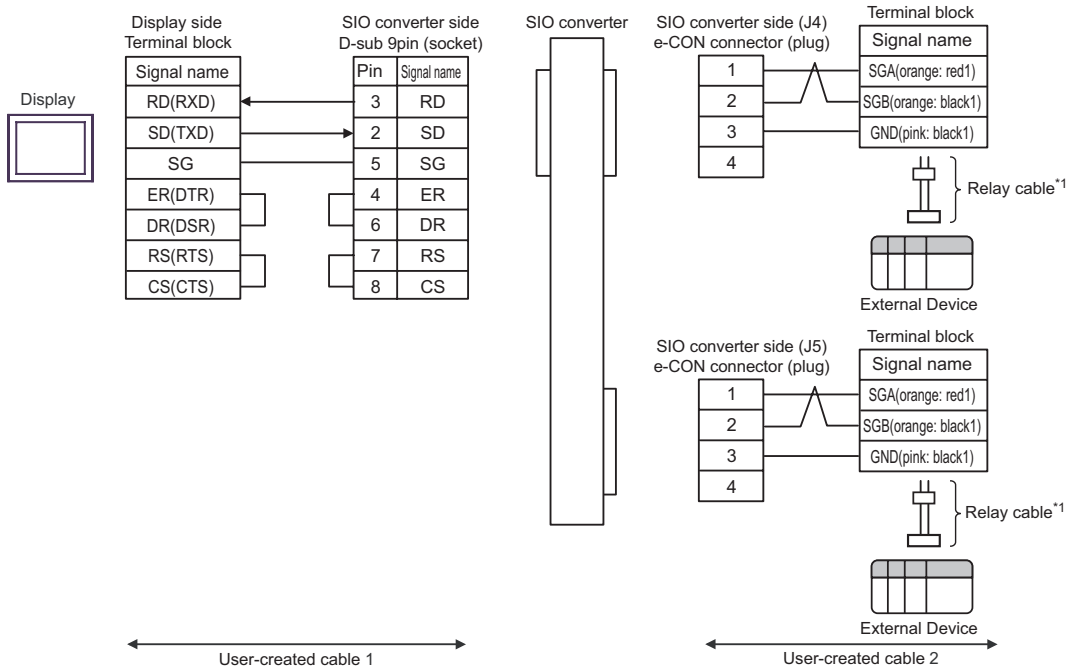

\*1 We recommend the IAI Corporation CB-ERC-PWBIO□□□□ or CB-ERC-PWBIO□□□□-RB as the relay cable.

6G)

- 1:1 connection

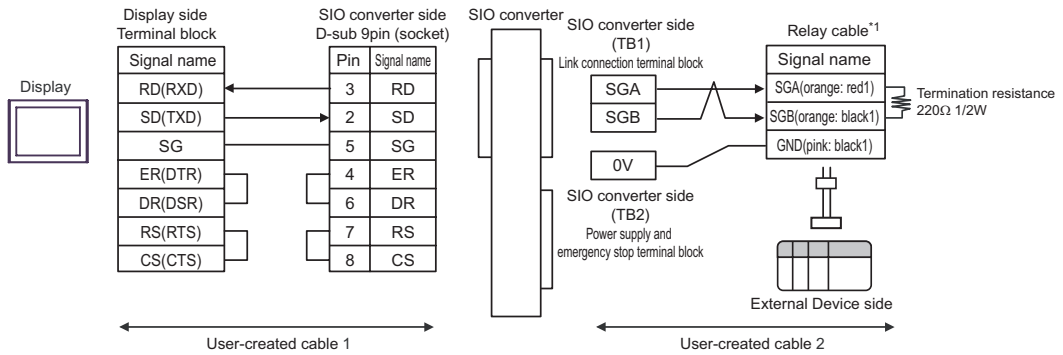

\*1 We recommend the IAI Corporation CB-ERC-PWBIO□□□□ or CB-ERC-PWBIO□□□□-RB as the relay cable.

- 1:n connection

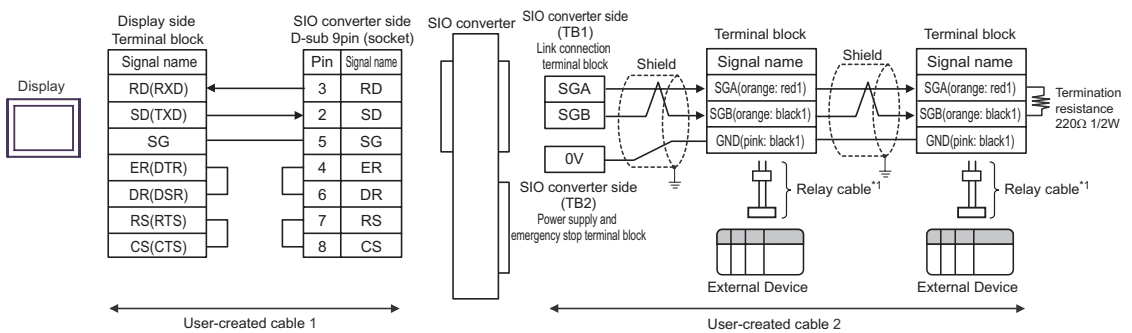

\*1 We recommend the IAI Corporation CB-ERC-PWBIO□□□□ or CB-ERC-PWBIO□□□□-RB as the relay cable.

**NOTE**

- When connecting to more than one equipment, connect the terminal block.

6H)

- 1:1 connection

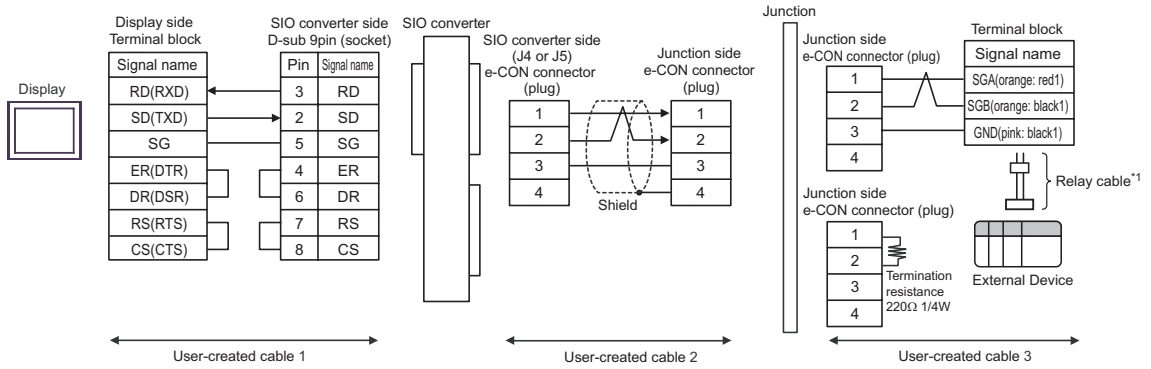

\*1 We recommend the IAI Corporation CB-ERC-PWBIO□□□□ or CB-ERC-PWBIO□□□□-RB as the relay cable.

• 1:n connection

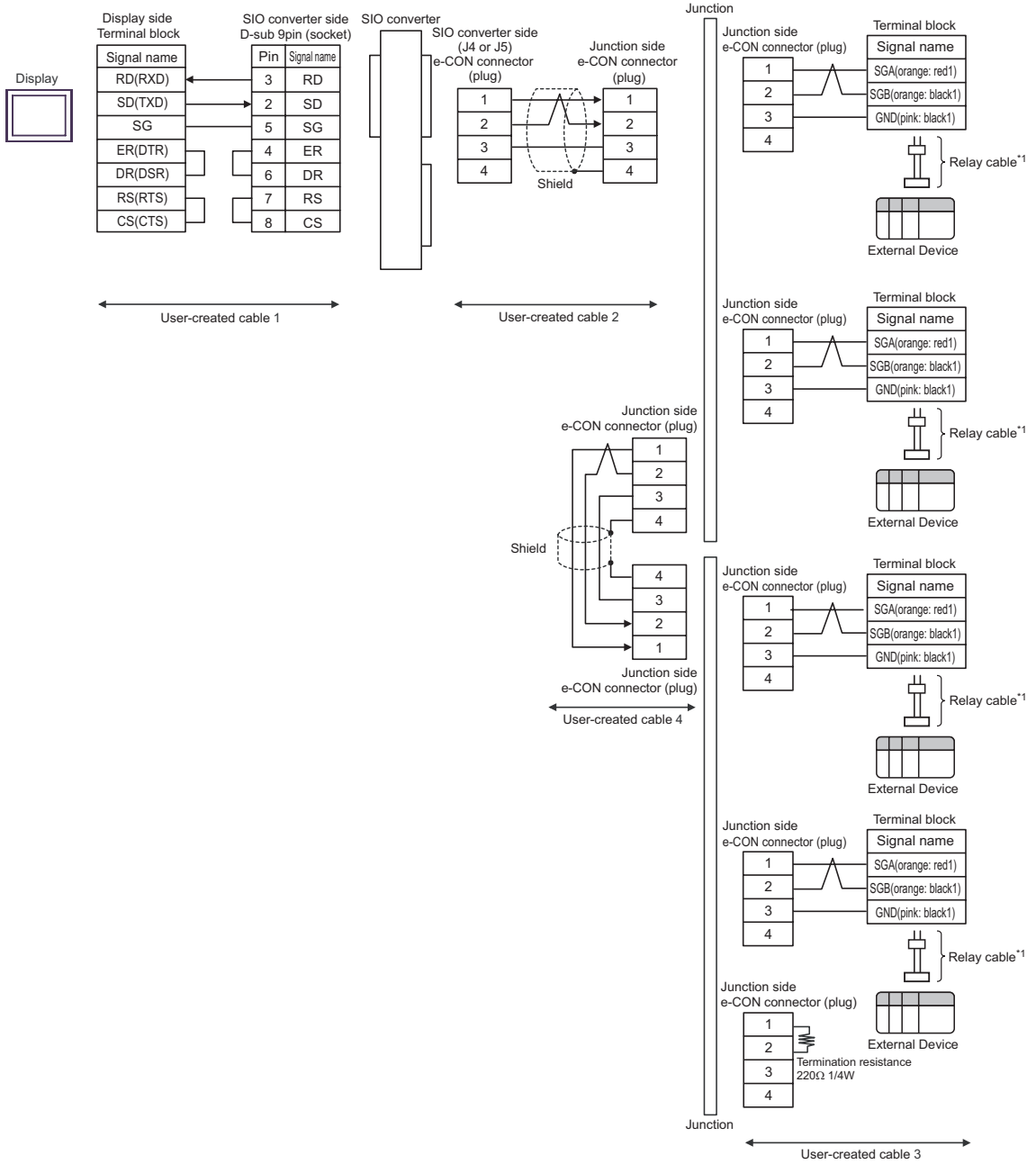

\*1 We recommend the IAI Corporation CB-ERC-PWBIO□□□□ or CB-ERC-PWBIO□□□□-RB as the relay cable.

6I)

- 1:1 connection

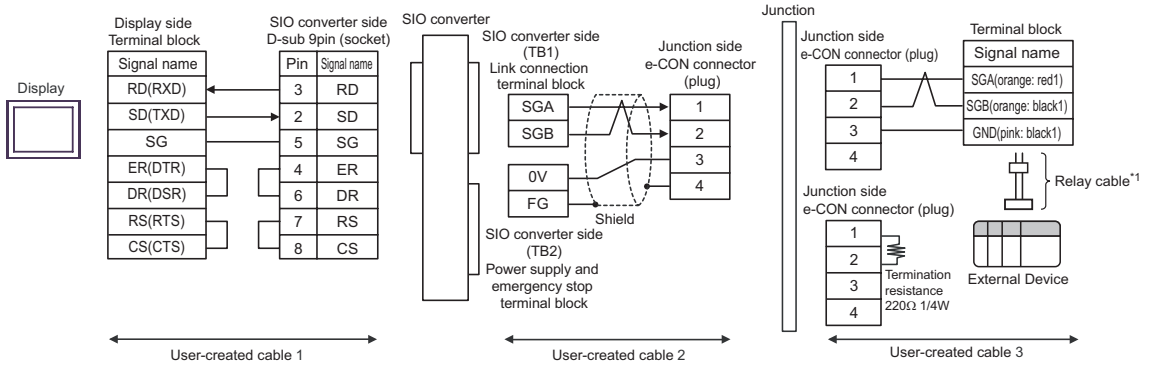

\*1 We recommend the IAI Corporation CB-ERC-PWBIO□□□□ or CB-ERC-PWBIO□□□□-RB as the relay cable.

• 1:n connection

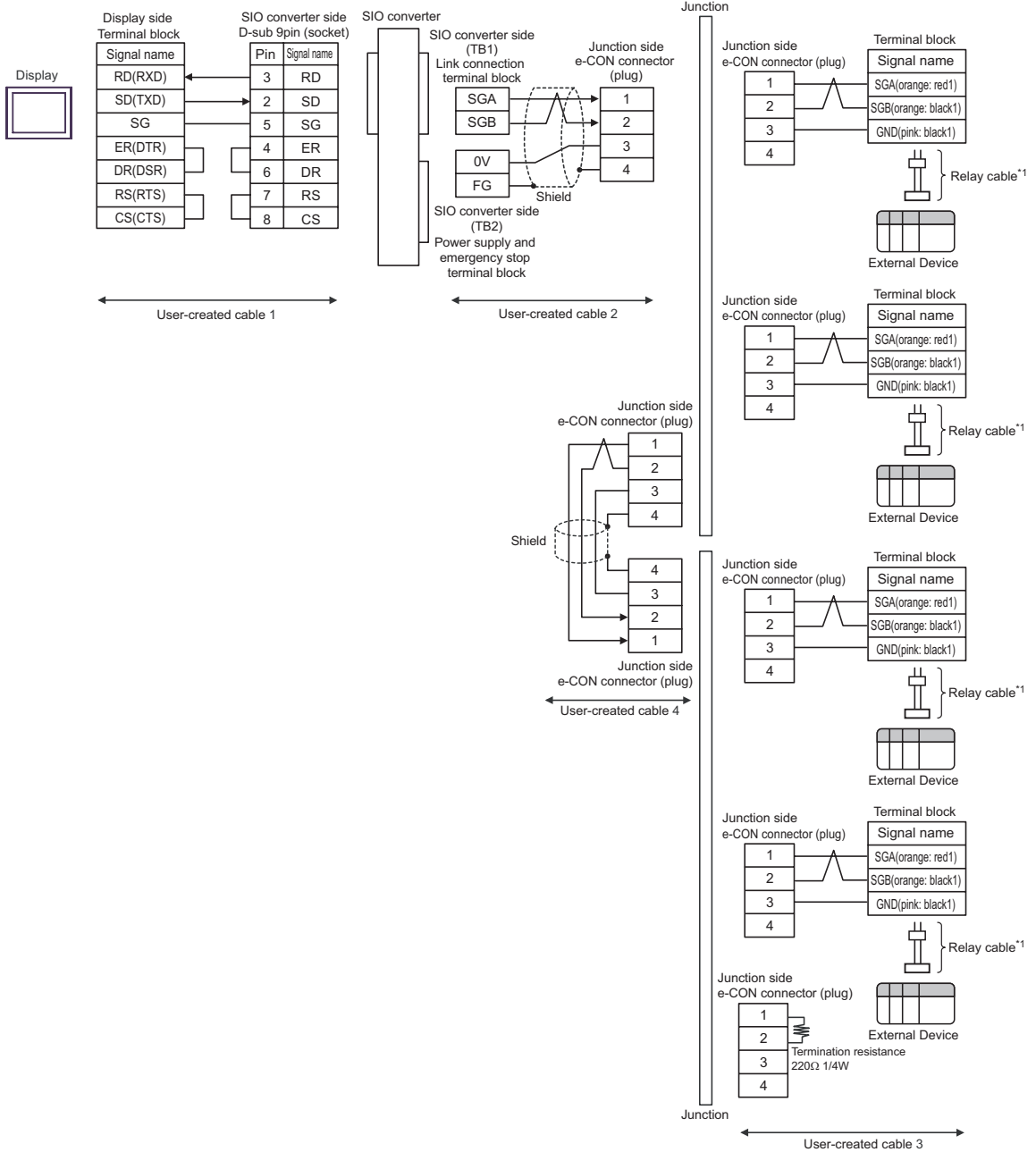

\*1 We recommend the IAI Corporation CB-ERC-PWBIO□□□□ or CB-ERC-PWBIO□□□□-RB as the relay cable.

6J)

- 1:1 connection

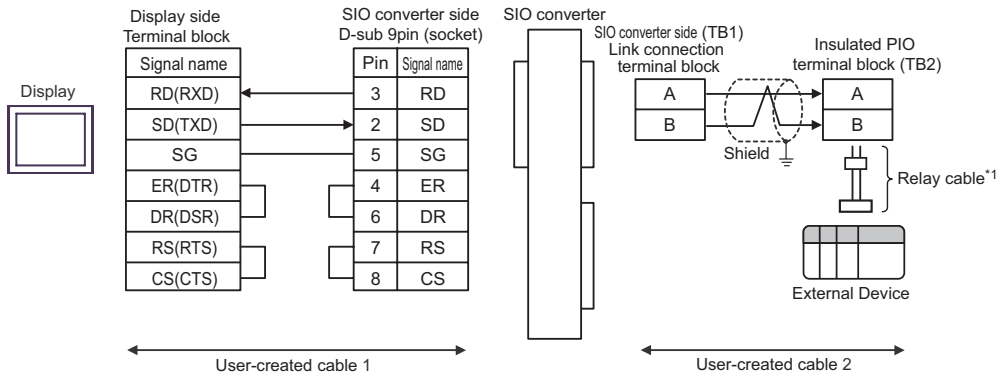

\*1 We recommend the IAI Corporation CB-ERC-PWBIO□□□-H6 or CB-ERC-PWBIO□□□-RB-H6 as the relay cable.

- 1:n connection

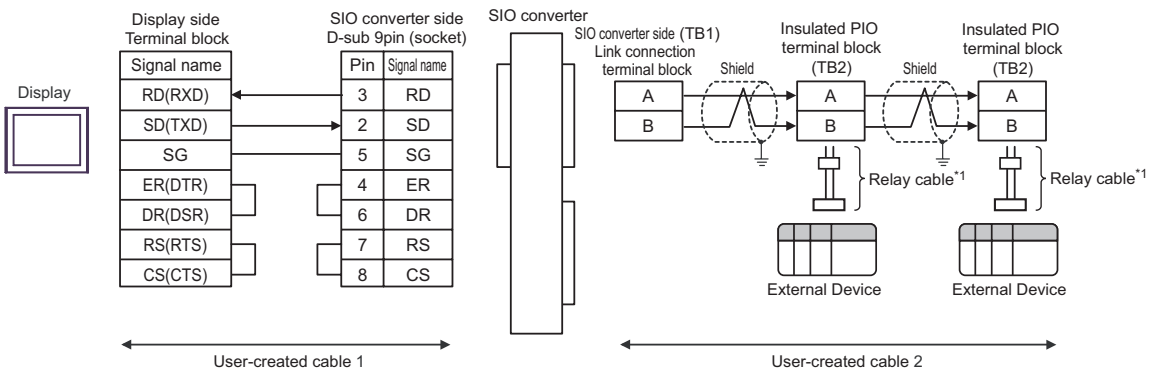

\*1 We recommend the IAI Corporation CB-ERC-PWBIO□□□-H6 or CB-ERC-PWBIO□□□-RB-H6 as the relay cable.

**NOTE** • Set the termination resistance connection switch of the PIO terminal block on the end to RTON side.



Cable Diagram 7

Display (Connection Port)	Cable		Notes
GP3000 (COM1) ST (COM1) LT (COM1) IPC*1 PC/AT	7A	RS232C conversion unit by IAI Corporation RCB-CV-MW + Communication cable by IAI Corporation CB-RCA-SIO050 + SIO converter by IAI Corporation RC□-TU-SIO-□ + User-created cable + Terminal block + Relay cable by IAI Corporation CB-ERC-PWBIO□□□ or CB-ERC-PWBIO□□□-RB	Cable length from SIO converter to External Device: 100m or less
	7B	RS232C conversion unit by IAI Corporation RCB-CV-MW + Communication cable by IAI Corporation CB-RCA-SIO050 + SIO converter by IAI Corporation RC□-TU-SIO-□ + User-created cable + Relay cable by IAI Corporation CB-ERC-PWBIO□□□ or CB-ERC-PWBIO□□□-RB	
	7C	RS232C conversion unit by IAI Corporation RCB-CV-MW + Communication cable by IAI Corporation CB-RCA-SIO050 + SIO converter by IAI Corporation RC□-TU-SIO-□ + User-created cable 1 + Junction by AMP*2 5-1473574-4 + User-created cable 2 + Terminal block + Relay cable by IAI Corporation CB-ERC-PWBIO□□□ or CB-ERC-PWBIO□□□-RB	

continued to next page

Display (Connection Port)	Cable		Notes
GP3000 (COM1) ST (COM1) LT (COM1) IPC*1 PC/AT	7D	RS232C conversion unit by IAI Corporation RCB-CV-MW + Communication cable by IAI Corporation CB-RCA-SIO050 + SIO converter by IAI Corporation RC□-TU-SIO-□ + User-created cable 1 + Junction by AMP*2 5-1473574-4 + User-created cable 2 + Terminal block + Relay cable by IAI Corporation CB-ERC-PWBIO□□□□ or CB-ERC-PWBIO□□□□-RB	Cable length from SIO converter to External Device: 100m or less
	7E	RS232C conversion unit by IAI Corporation RCB-CV-MW + Communication cable by IAI Corporation CB-RCA-SIO050 + SIO converter by IAI Corporation RC□-TU-SIO-□ + User-created cable + Insulated PIO terminal block by IAI Corporation RC□-TU-PIO-□ + Relay cable by IAI Corporation CB-ERC-PWBIO□□□□-H6 or CB-ERC-PWBIO□□□□-RB-H6	

continued to next page

Display (Connection Port)	Cable		Notes
GP-4105 (COM1)	7F	User-created cable + RS232C conversion unit by IAI Corporation RCB-CV-MW + Communication cable by IAI Corporation CB-RCA-SIO050 + SIO converter by IAI Corporation RC□-TU-SIO-□ + User-created cable + Terminal block + Relay cable by IAI Corporation CB-ERC-PWBIO□□□ or CB-ERC-PWBIO□□□-RB	Cable length from SIO converter to External Device: 100m or less
	7G	User-created cable + RS232C conversion unit by IAI Corporation RCB-CV-MW + Communication cable by IAI Corporation CB-RCA-SIO050 + SIO converter by IAI Corporation RC□-TU-SIO-□ + User-created cable + Relay cable by IAI Corporation CB-ERC-PWBIO□□□ or CB-ERC-PWBIO□□□-RB	

continued to next page

Display (Connection Port)	Cable		Notes
GP-4105 (COM1)	7H	User-created cable + RS232C conversion unit by IAI Corporation RCB-CV-MW + Communication cable by IAI Corporation CB-RCA-SIO050 + SIO converter by IAI Corporation RC□-TU-SIO-□ + User-created cable 1 + Junction by AMP*2 5-1473574-4 + User-created cable 2 + Terminal block + Relay cable by IAI Corporation CB-ERC-PWBIO□□□ or CB-ERC-PWBIO□□□-RB	Cable length from SIO converter to External Device: 100m or less
	7I	User-created cable + RS232C conversion unit by IAI Corporation RCB-CV-MW + Communication cable by IAI Corporation CB-RCA-SIO050 + SIO converter by IAI Corporation RC□-TU-SIO-□ + User-created cable 1 + Junction by AMP*2 5-1473574-4 + User-created cable 2 + Terminal block + Relay cable by IAI Corporation CB-ERC-PWBIO□□□ or CB-ERC-PWBIO□□□-RB	

continued to next page

Display (Connection Port)	Cable		Notes
GP-4105 (COM1)	7J	User-created cable + RS232C conversion unit by IAI Corporation RCB-CV-MW + Communication cable by IAI Corporation CB-RCA-SIO050 + SIO converter by IAI Corporation RC□-TU-SIO-□ + User-created cable + Insulated PIO terminal block by IAI Corporation RC□-TU-PIO-□ + Relay cable by IAI Corporation CB-ERC-PWBIO□□□-H6 or CB-ERC-PWBIO□□□-RB-H6	Cable length from SIO converter to External Device: 100m or less

\*1 Only the COM port which can communicate by RS-232C can be used.

 ■ IPC COM Port (page 5)

\*2 When using more than one junction by AMP, user-created cable 3 is required.

**NOTE**

- RS232C conversion unit (RCB-CV-MW) and communication cable (CB-RCA-SIO050) are accessories of PC Interface Software (RCM-101-MW) by IAI Corporation.
- When connecting to 3 or more External Devices, use link connection terminal block or junction by AMP.

7A)

- 1:1 connection

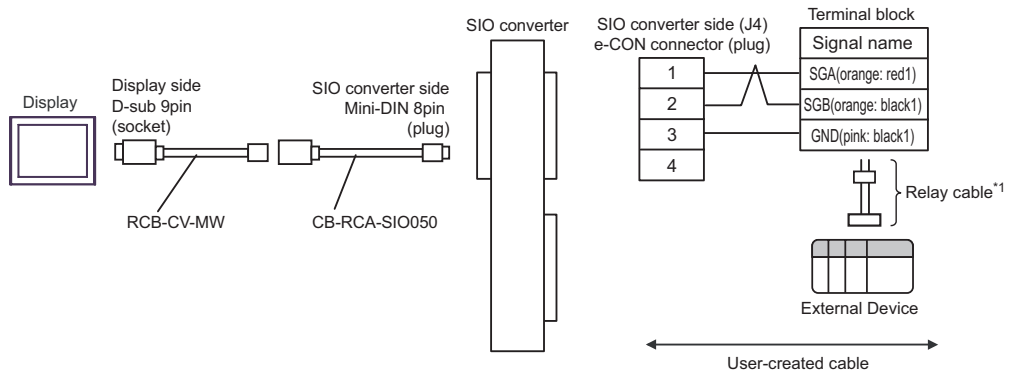

\*1 We recommend the IAI Corporation CB-ERC-PWBIO□□□□ or CB-ERC-PWBIO□□□□-RB as the relay cable.

- 1:n connection

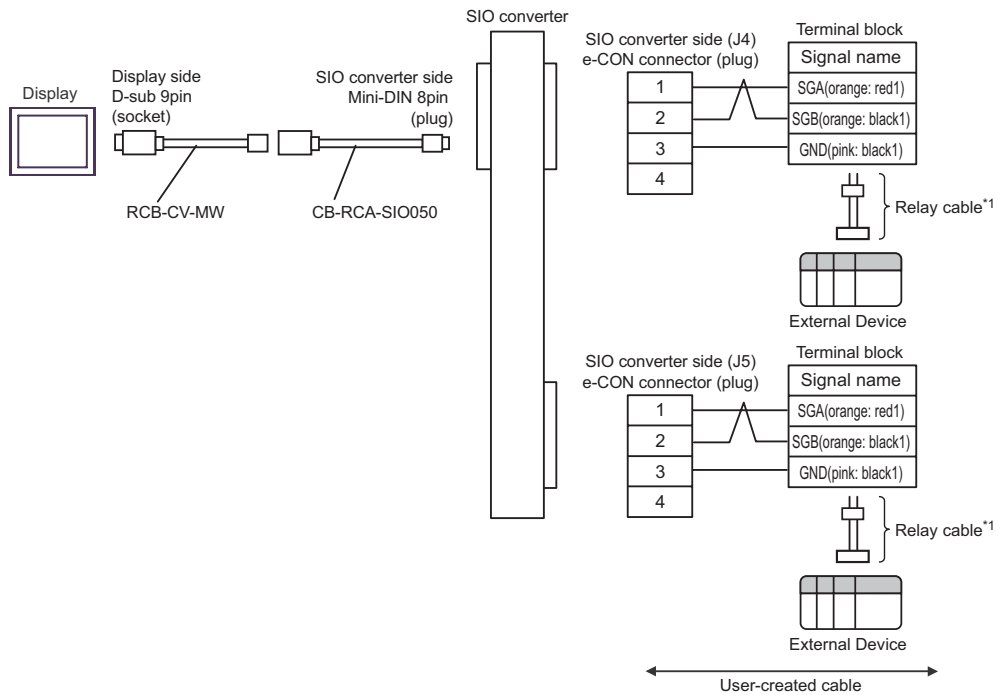

\*1 We recommend the IAI Corporation CB-ERC-PWBIO□□□□ or CB-ERC-PWBIO□□□□-RB as the relay cable.

7B)

- 1:1 connection

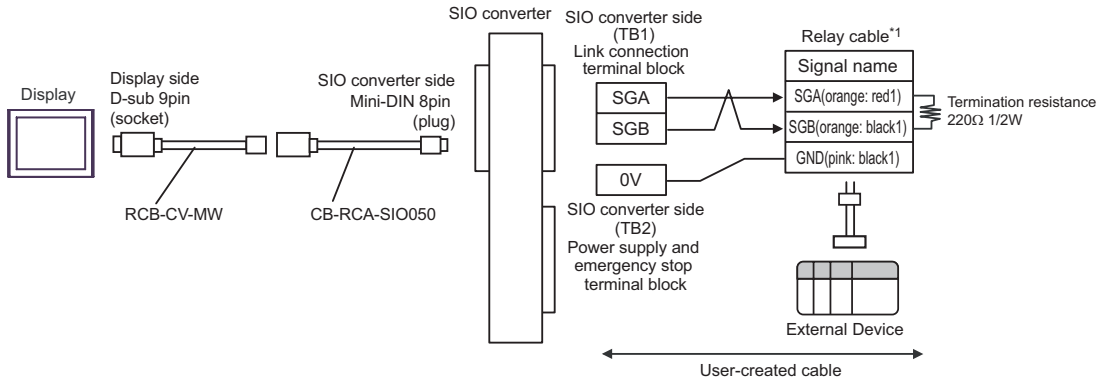

\*1 We recommend the IAI Corporation CB-ERC-PWBIO□□□□ or CB-ERC-PWBIO□□□□-RB as the relay cable.

- 1:n connection

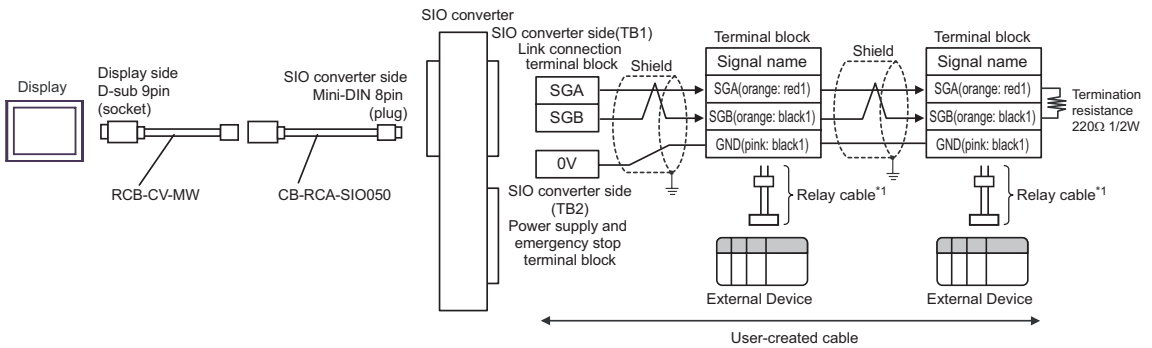

\*1 We recommend the IAI Corporation CB-ERC-PWBIO□□□□ or CB-ERC-PWBIO□□□□-RB as the relay cable.

**NOTE**

- When connecting to more than one equipment, connect the terminal block.

7C)

- 1:1 connection

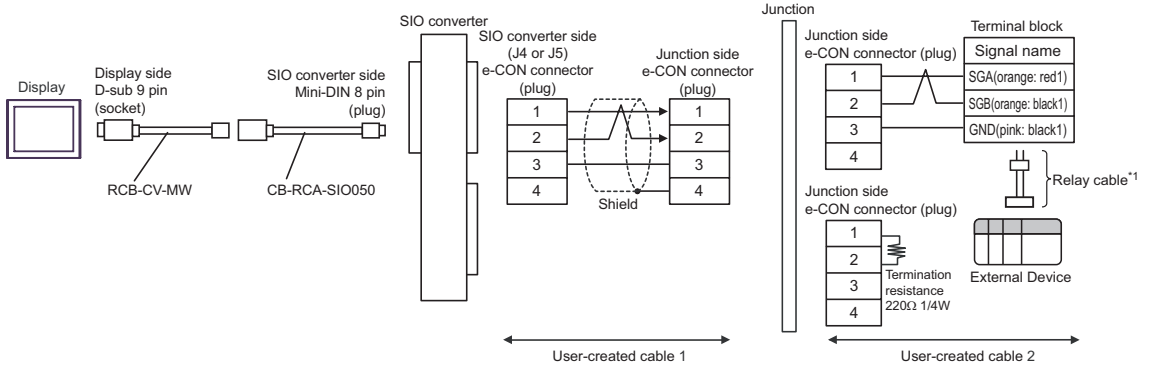

\*1 We recommend the IAI Corporation CB-ERC-PWBIO□□□□ or CB-ERC-PWBIO□□□□-RB as the relay cable.



- 1:n connection

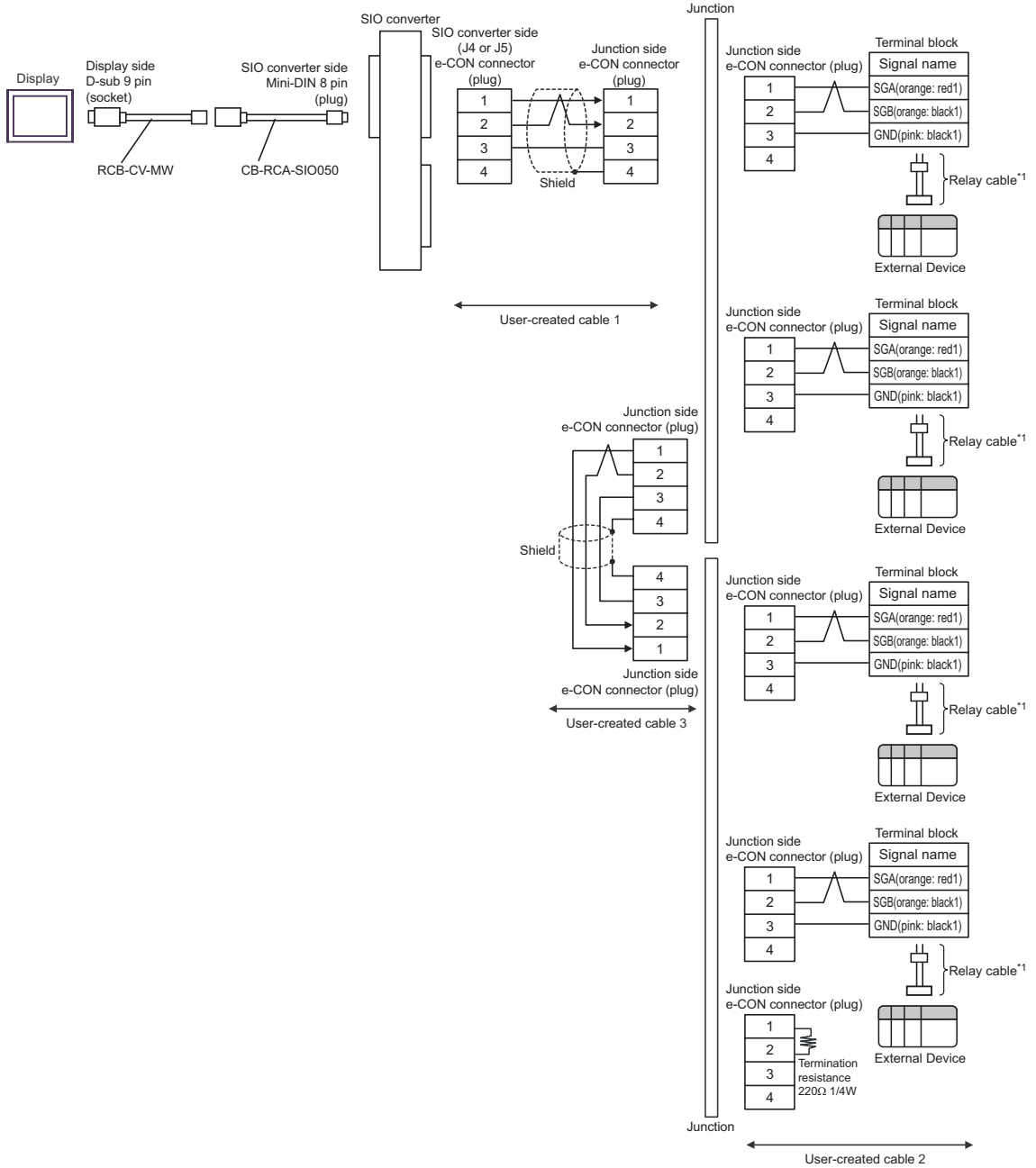

\*1 We recommend the IAI Corporation CB-ERC-PWBIO□□□□ or CB-ERC-PWBIO□□□□-RB as the relay cable.

7D)

- 1:1 connection

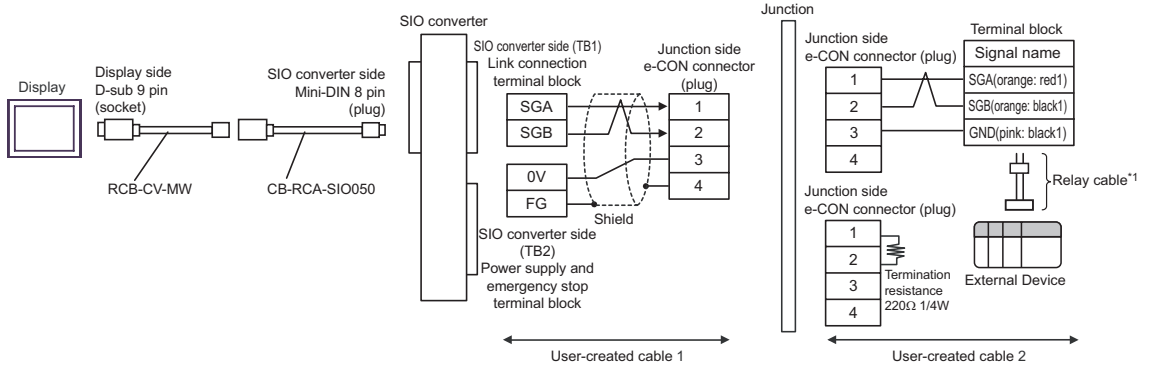

\*1 We recommend the IAI Corporation CB-ERC-PWBIO□□□□ or CB-ERC-PWBIO□□□□-RB as the relay cable.

- 1:n connection

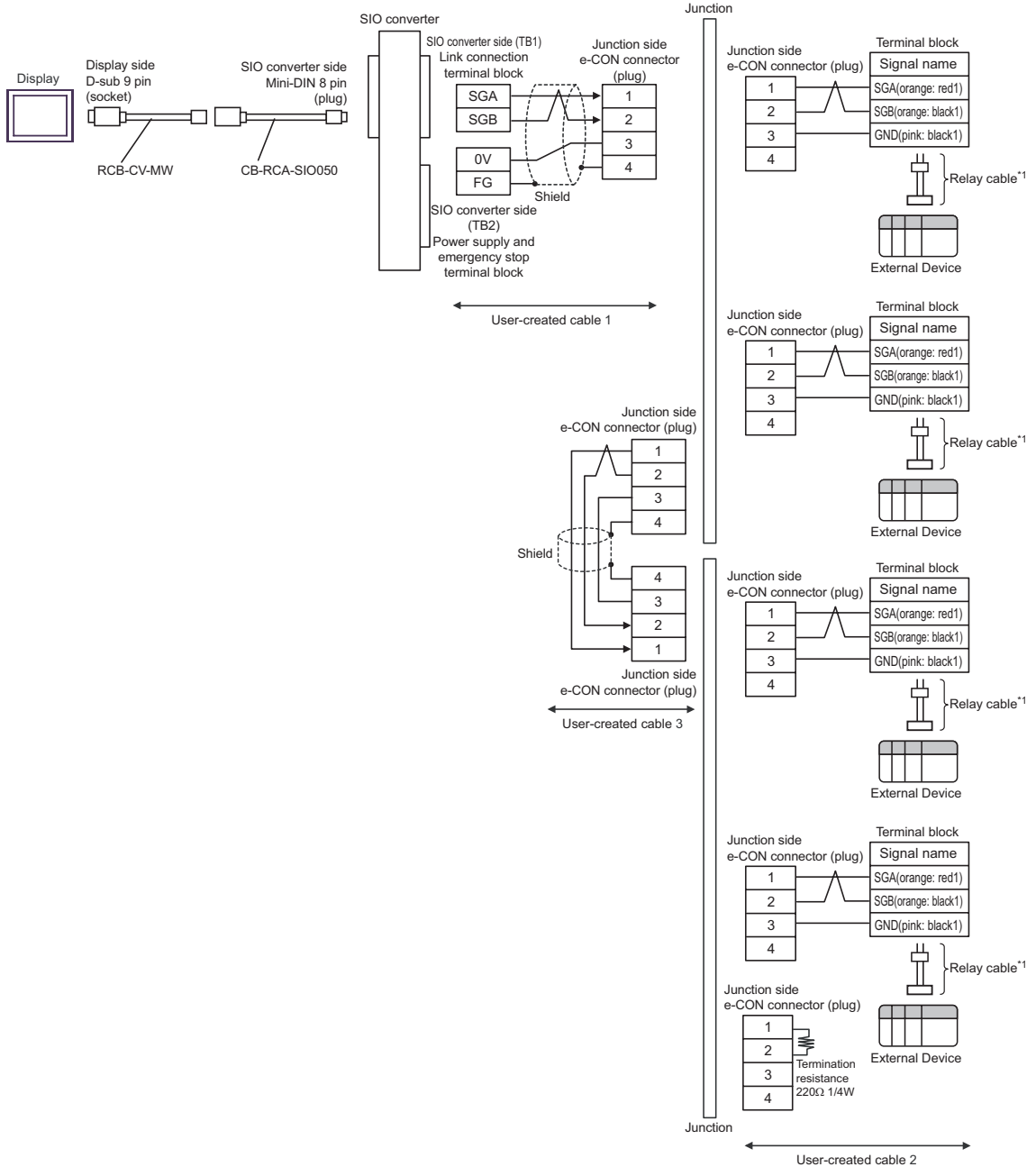

\*1 We recommend the IAI Corporation CB-ERC-PWBIO□□□□ or CB-ERC-PWBIO□□□□-RB as the relay cable.

7E)

- 1:1 connection

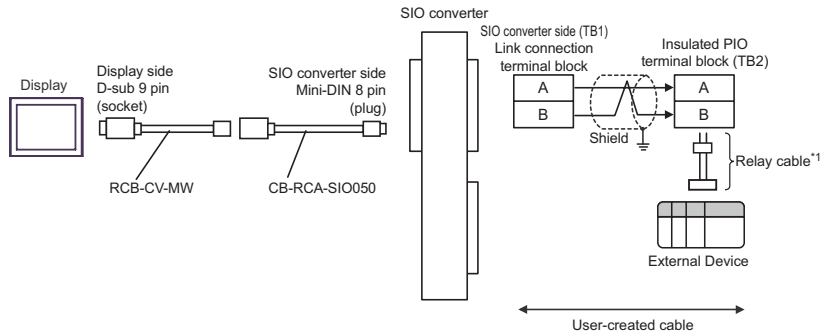

\*1 We recommend the IAI Corporation CB-ERC-PWBIO□□□-H6 or CB-ERC-PWBIO□□□-RB-H6 as the relay cable.

- 1:n connection

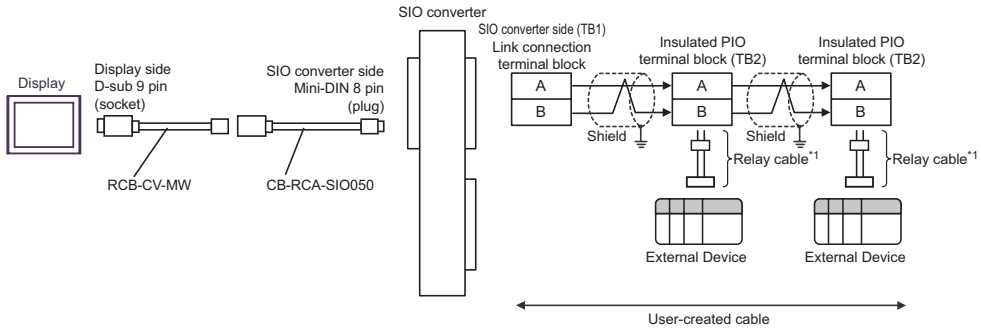

\*1 We recommend the IAI Corporation CB-ERC-PWBIO□□□-H6 or CB-ERC-PWBIO□□□-RB-H6 as the relay cable.

**NOTE**

- Set the termination resistance connection switch of the PIO terminal block on the end to RTON side.

7F)

- 1:1 connection

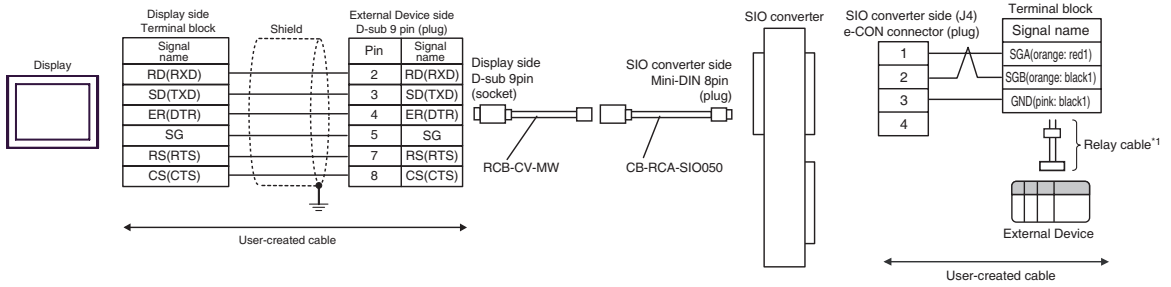

\*1 We recommend the IAI Corporation CB-ERC-PWBIO□□□□ or CB-ERC-PWBIO□□□□-RB as the relay cable.

- 1:n connection

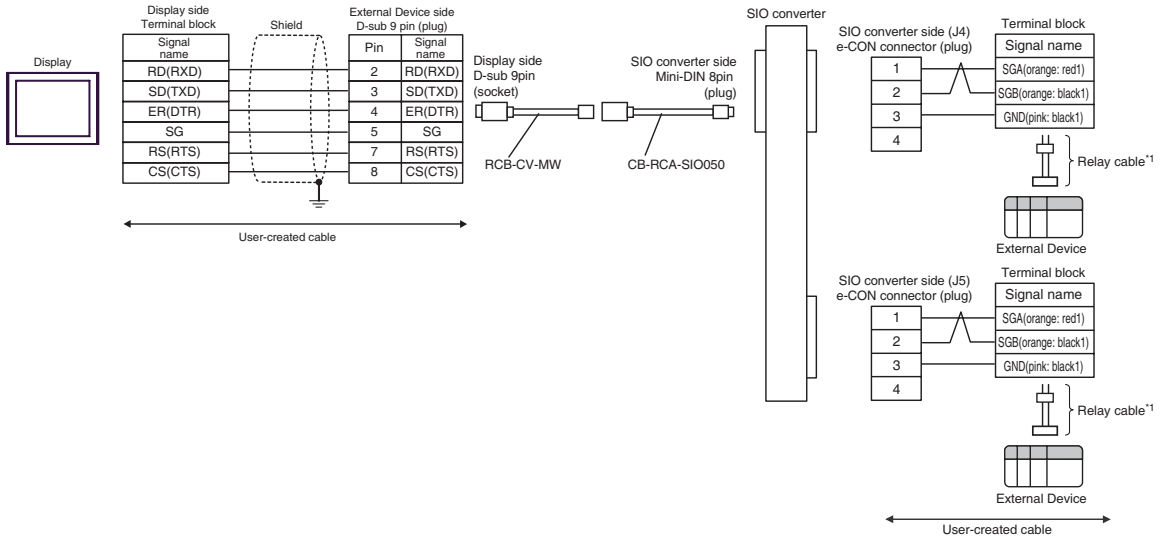

\*1 We recommend the IAI Corporation CB-ERC-PWBIO□□□□ or CB-ERC-PWBIO□□□□-RB as the relay cable.

7G)

- 1:1 connection

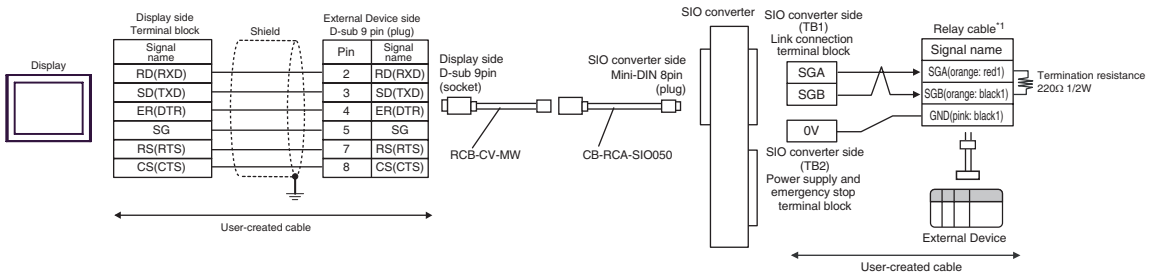

\*1 We recommend the IAI Corporation CB-ERC-PWBIO□□□□ or CB-ERC-PWBIO□□□□-RB as the relay cable.

- 1:n connection

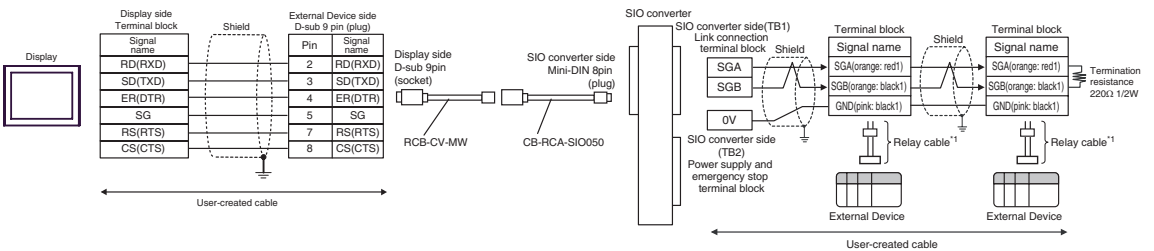

\*1 We recommend the IAI Corporation CB-ERC-PWBIO□□□□ or CB-ERC-PWBIO□□□□-RB as the relay cable.

**NOTE**

- When connecting to more than one equipment, connect the terminal block.

7H)

- 1:1 connection

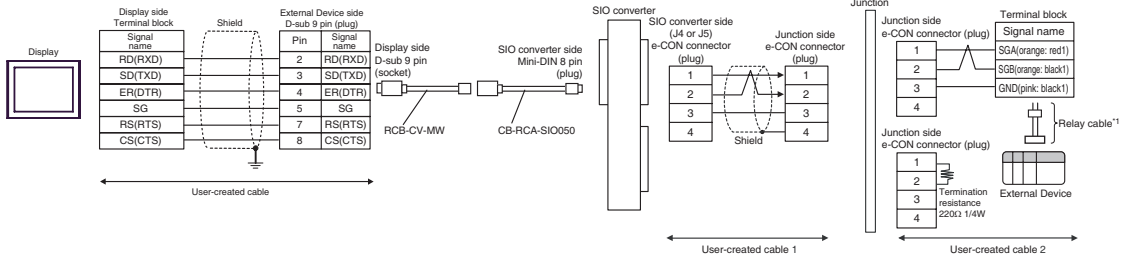

- \*1 We recommend the IAI Corporation CB-ERC-PWBIO□□□□ or CB-ERC-PWBIO□□□□-RB as the relay cable.

- 1:n connection

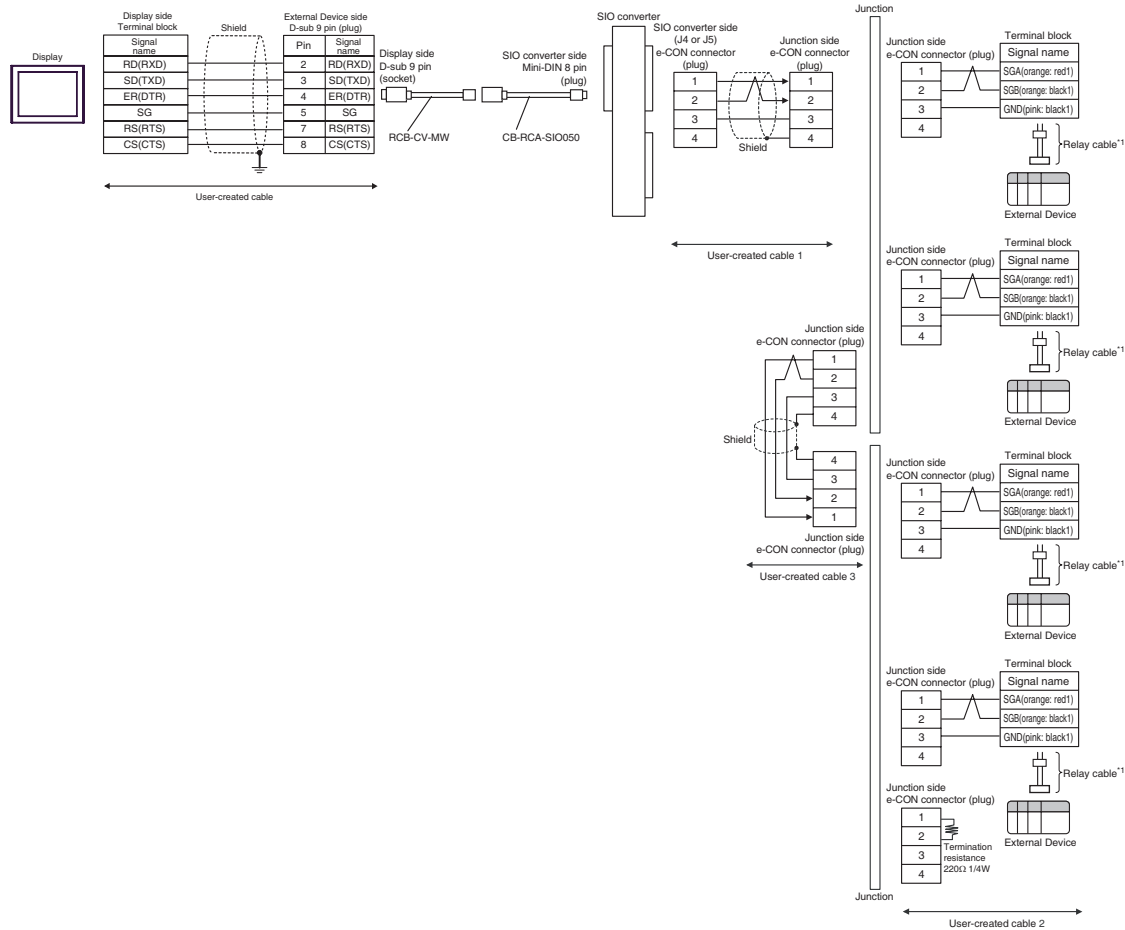

- \*1 We recommend the IAI Corporation CB-ERC-PWBIO□□□□ or CB-ERC-PWBIO□□□□-RB as the relay cable.

7I)

- 1:1 connection

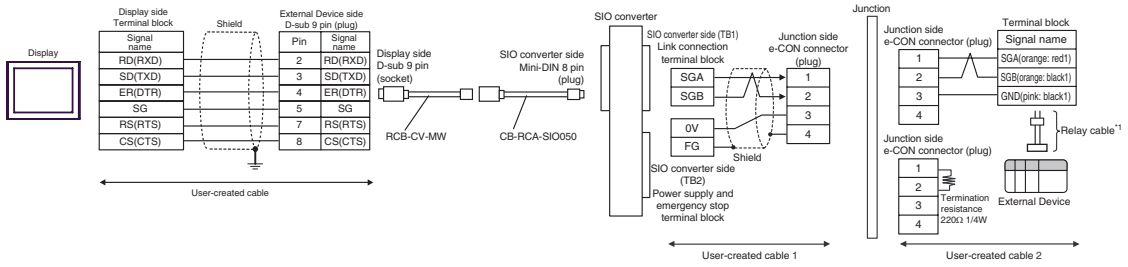

\*1 We recommend the IAI Corporation CB-ERC-PWBIO□□□□ or CB-ERC-PWBIO□□□□-RB as the relay cable.

- 1:n connection

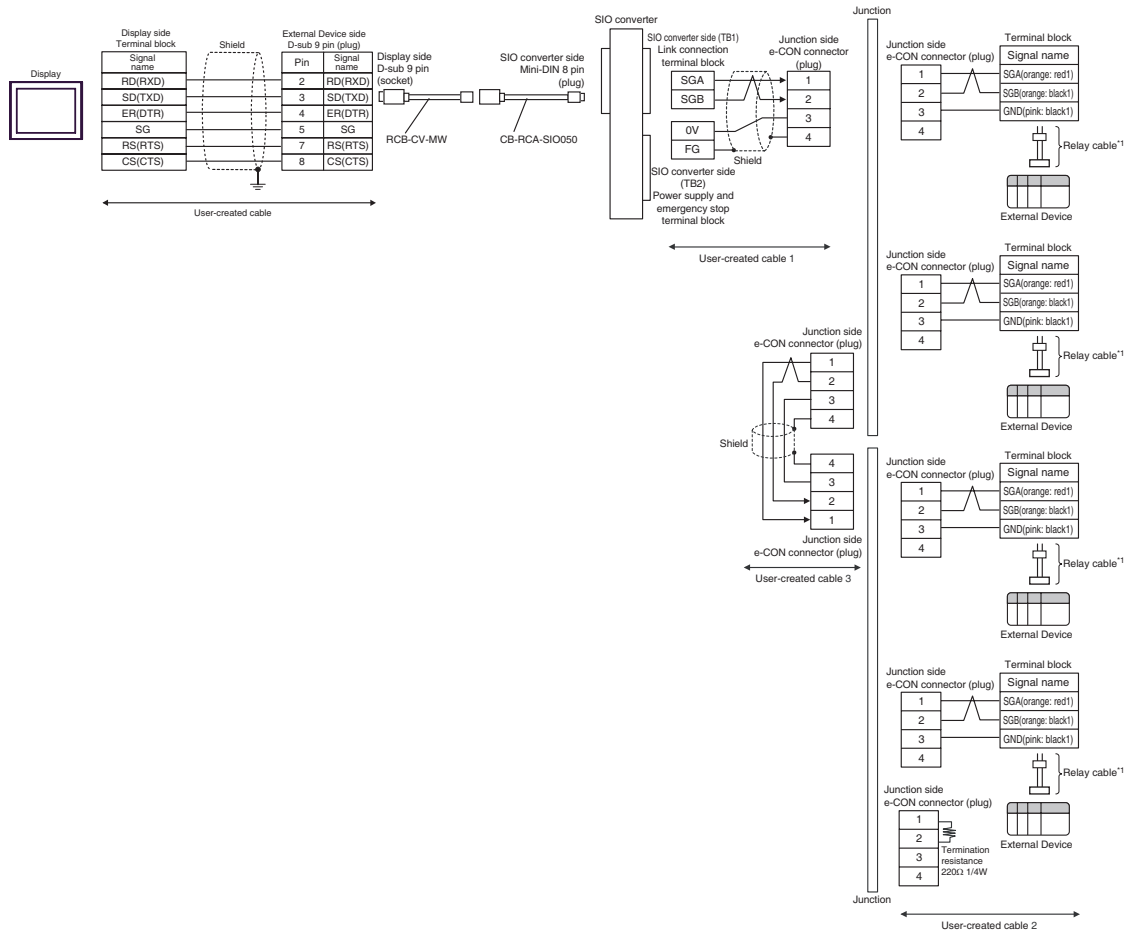

\*1 We recommend the IAI Corporation CB-ERC-PWBIO□□□□ or CB-ERC-PWBIO□□□□-RB as the relay cable.



7J)

- 1:1 connection

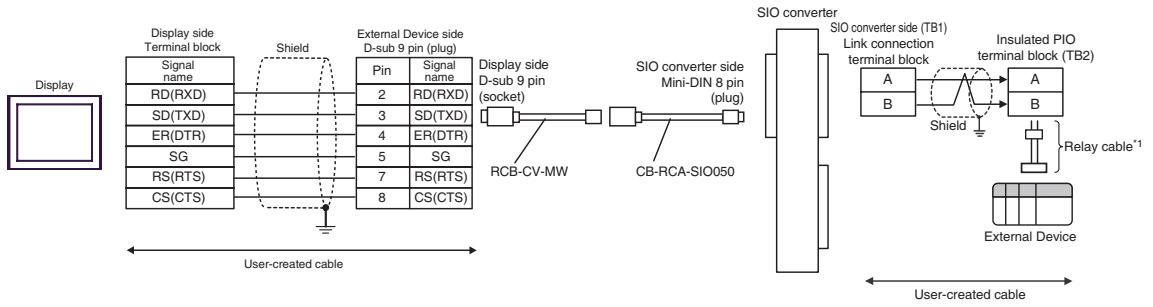

\*1 We recommend the IAI Corporation CB-ERC-PWBIO□□□-H6 or CB-ERC-PWBIO□□□-RB-H6 as the relay cable.

- 1:n connection

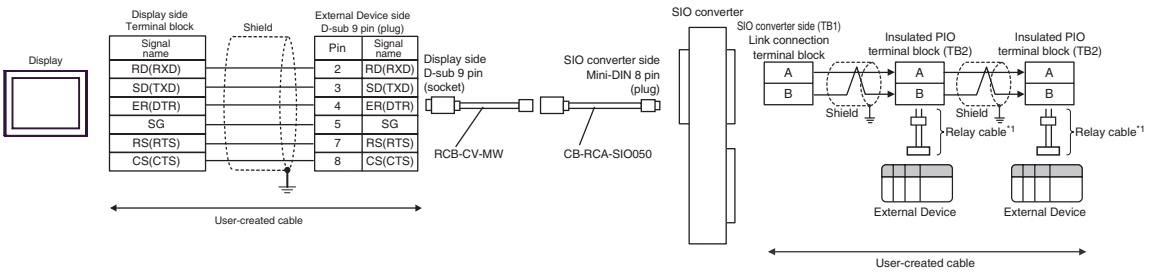

\*1 We recommend the IAI Corporation CB-ERC-PWBIO□□□-H6 or CB-ERC-PWBIO□□□-RB-H6 as the relay cable.

**NOTE**

- Set the termination resistance connection switch of the PIO terminal block on the end to RTON side.

Cable Diagram 8

Display (Connection Port)	Cable		Notes
GP3000 (COM1) ST (COM1) LT (COM1) IPC*1 PC/AT	8A	RS232C conversion unit by IAI Corporation RCB-CV-MW + Communication cable for PC connection by IAI Corporation CB-ERC2-SIO020 + Relay cable by IAI Corporation CB-ERC2-PWBIO□□□□ or CB-ERC2-PWBIO□□□□-RB	
GP-4105 (COM1)	8B	User-created cable + RS232C conversion unit by IAI Corporation RCB-CV-MW + Communication cable for PC connection by IAI Corporation CB-ERC2-SIO020 + Relay cable by IAI Corporation CB-ERC2-PWBIO□□□□ or CB-ERC2-PWBIO□□□□-RB	

\*1 Only the COM port which can communicate by RS-232C can be used.

☞ ■ IPC COM Port (page 5)

**NOTE** • RS232C conversion unit (RCB-CV-MW) and communication cable (CB-ERC2-SIO020) are accessories of PC Interface Software (RCM-101-MW) by IAI Corporation.

8A)

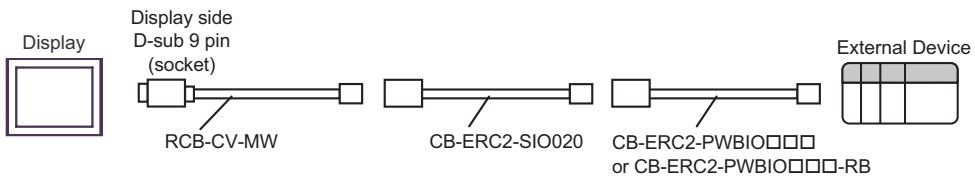

8B)

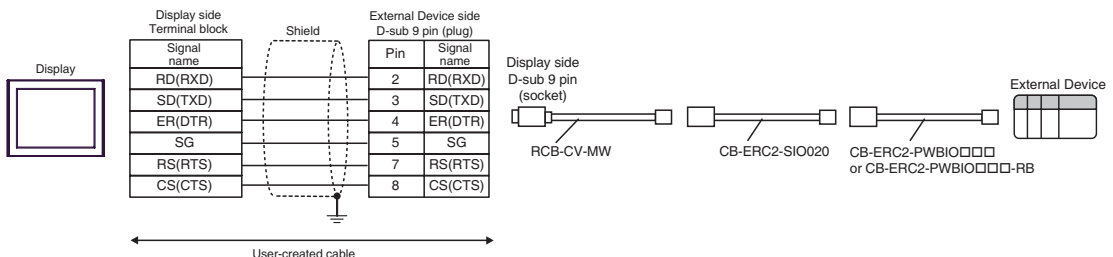

Cable Diagram 9

Display (Connection Port)	Cable		Notes
GP3000* <sup>1</sup> (COM1) AGP-3302B (COM2) ST* <sup>2</sup> (COM2) LT (COM1)	9A	COM port conversion adapter by Pro-face CA3-ADPCOM-01 + Terminal block conversion adapter by Pro-face CA3-ADPTRM-01 + User-created cable 1 + Junction by AMP* <sup>3</sup> 5-1473574-4 + Relay cable by IAI Corporation CB-ERC2-CTL001 + Relay cable by IAI Corporation CB-ERC2-PWBIO□□□ or CB-ERC2-PWBIO□□□-RB	Cable length: 100m or less
	9B	User-created cable 1 + Junction by AMP* <sup>3</sup> 5-1473574-4 + Relay cable by IAI Corporation CB-ERC2-CTL001 + Relay cable by IAI Corporation CB-ERC2-PWBIO□□□ or CB-ERC2-PWBIO□□□-RB	
GP3000* <sup>4</sup> (COM2)	9C	Online adapter by Pro-face CA4-ADPONL-01 + Terminal block conversion adapter by Pro-face CA3-ADPTRM-01 + User-created cable 1 + Junction by AMP* <sup>3</sup> 5-1473574-4 + Relay cable by IAI Corporation CB-ERC2-CTL001 + Relay cable by IAI Corporation CB-ERC2-PWBIO□□□ or CB-ERC2-PWBIO□□□-RB	

continued to next page

Display (Connection Port)	Cable		Notes
GP3000 <sup>*4</sup> (COM2)	9D	Online adapter by Pro-face CA4-ADPONL-01 + User-created cable 1 + Junction by AMP <sup>*3</sup> 5-1473574-4 + Relay cable by IAI Corporation CB-ERC2-CTL001 + Relay cable by IAI Corporation CB-ERC2-PWBIO□□□ or CB-ERC2-PWBIO□□□-RB	
IPC <sup>*5</sup>	9E	COM port conversion adapter by Pro-face CA3-ADPCOM-01 + Terminal block conversion adapter by Pro-face CA3-ADPTRM-01 + User-created cable 1 + Junction by AMP <sup>*3</sup> 5-1473574-4 + Relay cable by IAI Corporation CB-ERC2-CTL001 + Relay cable by IAI Corporation CB-ERC2-PWBIO□□□ or CB-ERC2-PWBIO□□□-RB	Cable length: 100m or less
	9F	User-created cable 1 + Junction by AMP <sup>*3</sup> 5-1473574-4 + Relay cable by IAI Corporation CB-ERC2-CTL001 + Relay cable by IAI Corporation CB-ERC2-PWBIO□□□ or CB-ERC2-PWBIO□□□-RB	

continued to next page

Display (Connection Port)	Cable		Notes
GP-4106 (COM1)	9G	User-created cable 1 + Junction by AMP <sup>*3</sup> 5-1473574-4 + Relay cable by IAI Corporation CB-ERC2-CTL001 + Relay cable by IAI Corporation CB-ERC2-PWBIO□□□ or CB-ERC2-PWBIO□□□-RB	Cable length: 100m or less
GP-4107 (COM1)	9H	User-created cable 1 + Junction by AMP <sup>*3</sup> 5-1473574-4 + Relay cable by IAI Corporation CB-ERC2-CTL001 + Relay cable by IAI Corporation CB-ERC2-PWBIO□□□ or CB-ERC2-PWBIO□□□-RB	

- \*1 All GP3000 models except AGP-3302B
- \*2 All ST models except AST-3211A and AST-3302B
- \*3 When using more than one junction by AMP, user-created cable 2 is required.
- \*4 All GP3000 models except GP-3200 series and AGP-3302B
- \*5 Only the COM port which can communicate by RS-422/485 (2 wire) can be used.  
 ■ IPC COM Port (page 5)

9A)

- 1:1 connection

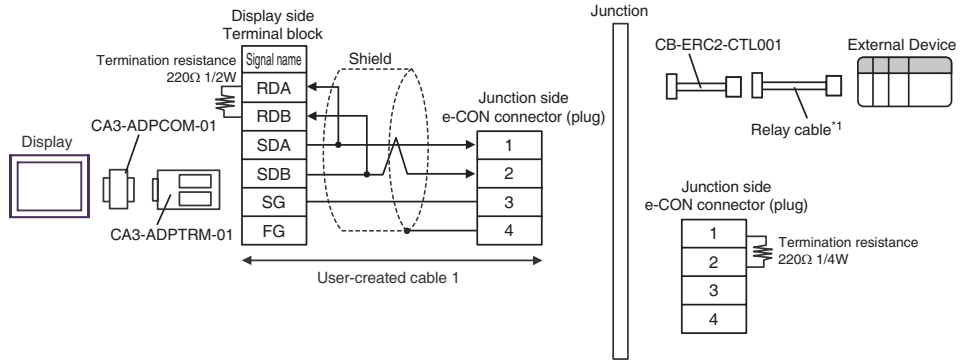

\*1 We recommend the IAI Corporation CB-ERC2-PWBIO□□□ or CB-ERC2-PWBIO□□□-RB as the relay cable.

- 1:n connection

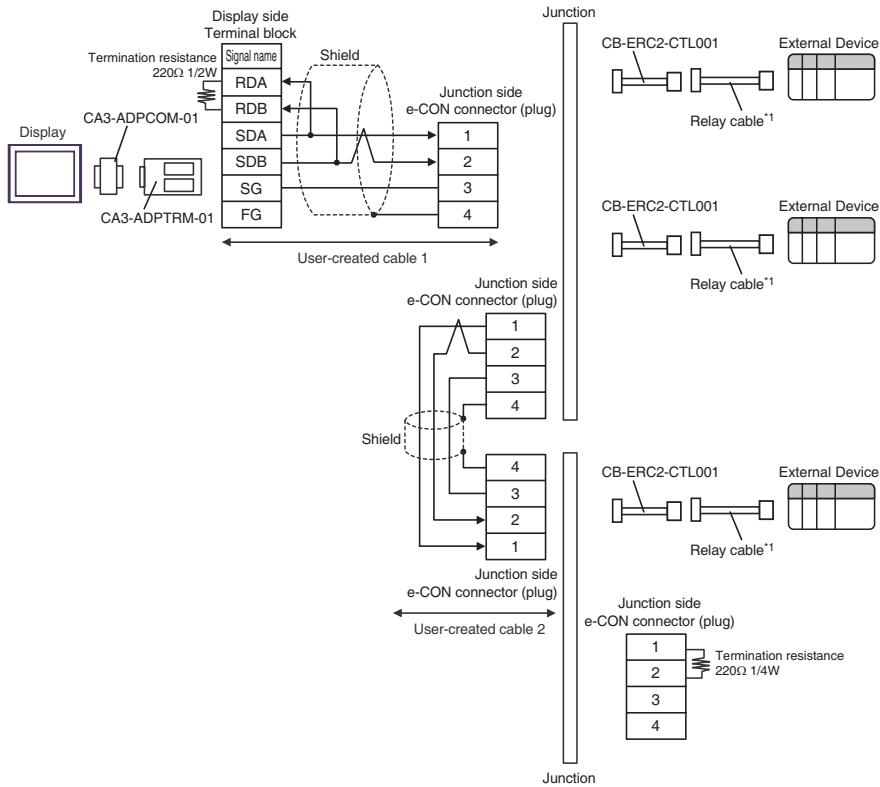

\*1 We recommend the IAI Corporation CB-ERC2-PWBIO□□□ or CB-ERC2-PWBIO□□□-RB as the relay cable.

9B)

- 1:1 connection

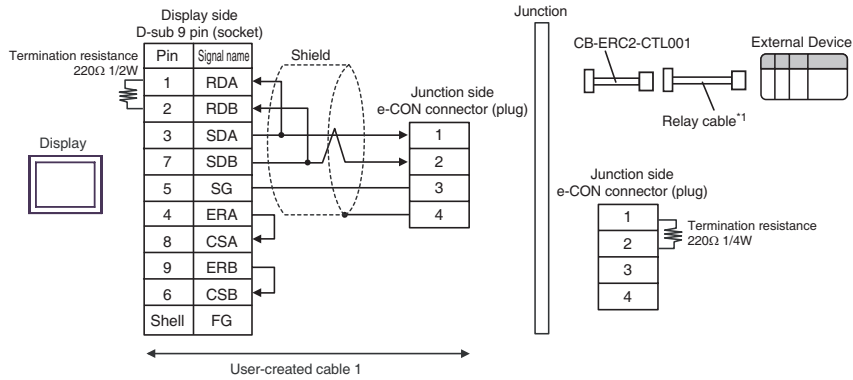

\*1 We recommend the IAI Corporation CB-ERC2-PWBIO□□□□ or CB-ERC2-PWBIO□□□□-RB as the relay cable.

- 1:n connection

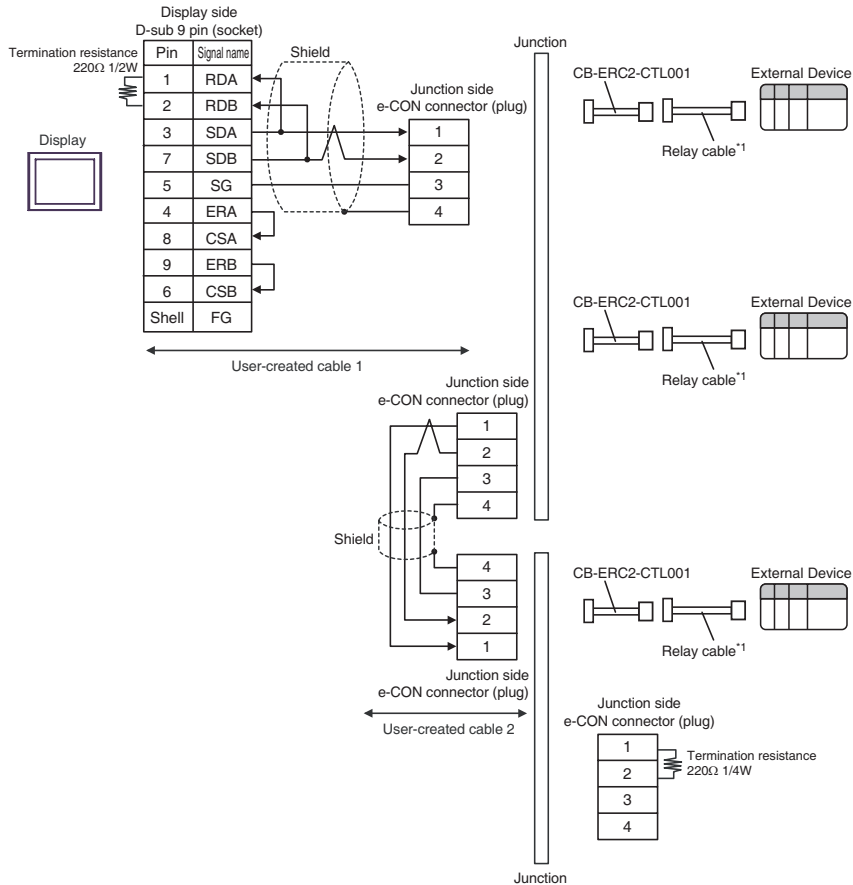

\*1 We recommend the IAI Corporation CB-ERC2-PWBIO□□□□ or CB-ERC2-PWBIO□□□□-RB as the relay cable.

9C)

- 1:1 connection

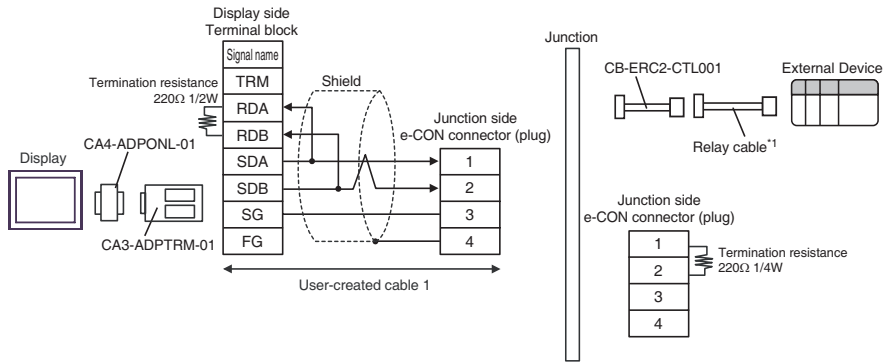

\*1 We recommend the IAI Corporation CB-ERC2-PWBIO□□□ or CB-ERC2-PWBIO□□□-RB as the relay cable.

- 1:n connection

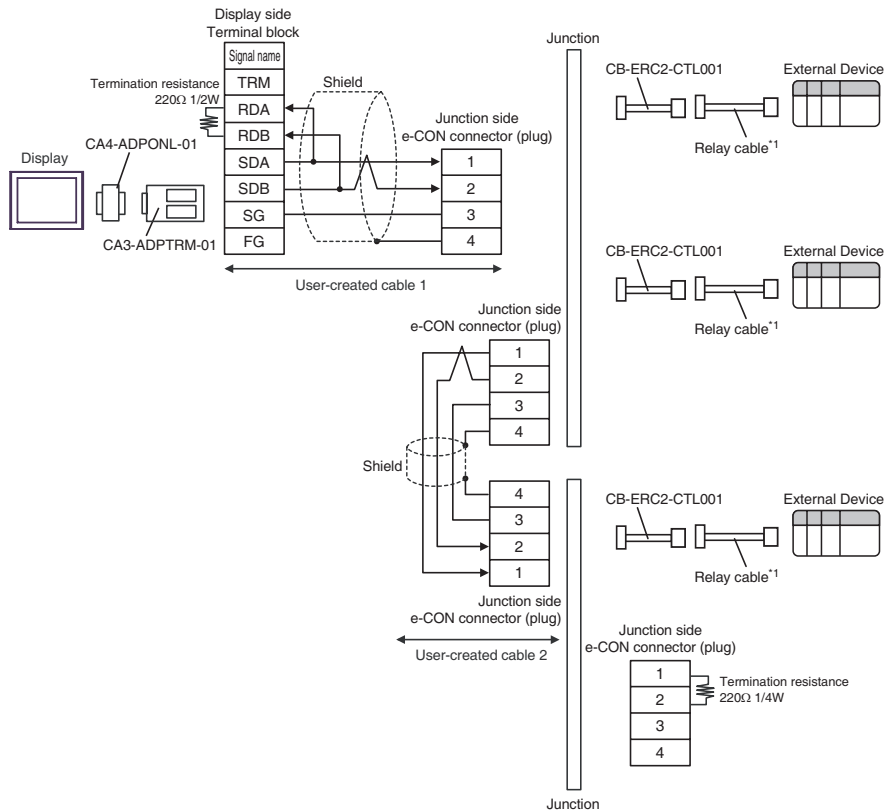

\*1 We recommend the IAI Corporation CB-ERC2-PWBIO□□□ or CB-ERC2-PWBIO□□□-RB as the relay cable.



9D)

- 1:1 connection

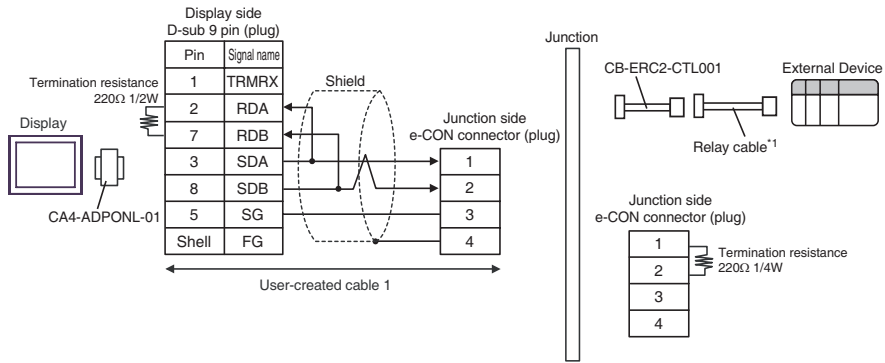

\*1 We recommend the IAI Corporation CB-ERC2-PWBIO□□□□ or CB-ERC2-PWBIO□□□□-RB as the relay cable.

- 1:n connection

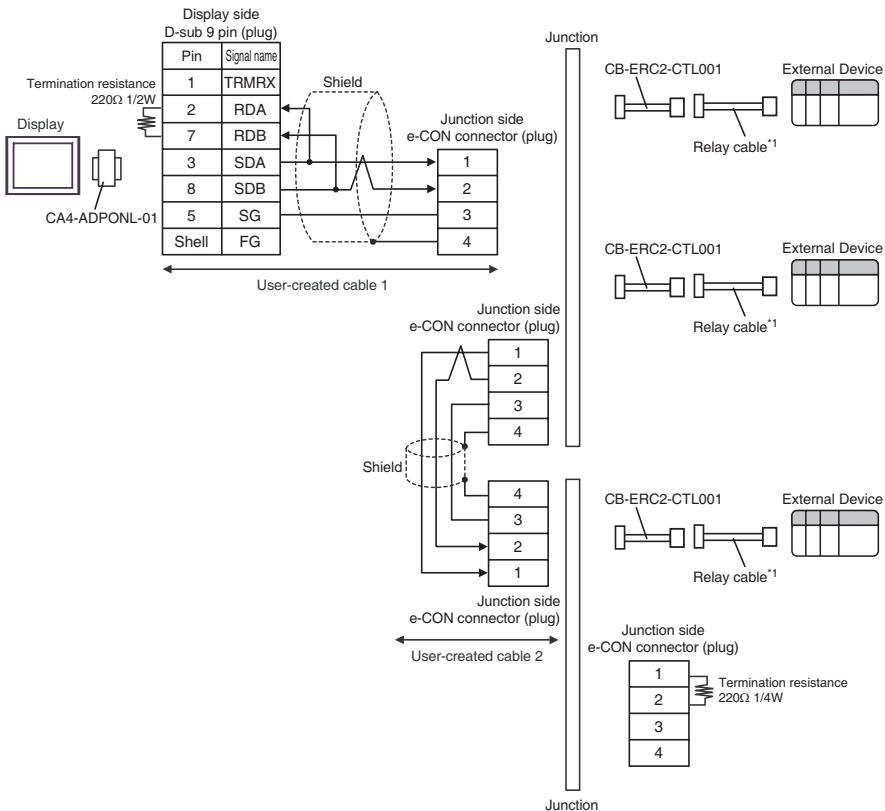

\*1 We recommend the IAI Corporation CB-ERC2-PWBIO□□□□ or CB-ERC2-PWBIO□□□□-RB as the relay cable.

9E)

- 1:1 connection

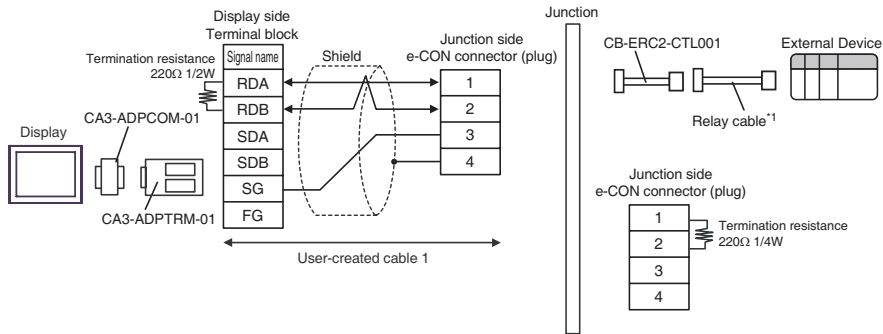

\*1 We recommend the IAI Corporation CB-ERC2-PWBIO□□□ or CB-ERC2-PWBIO□□□-RB as the relay cable.

- 1:n connection

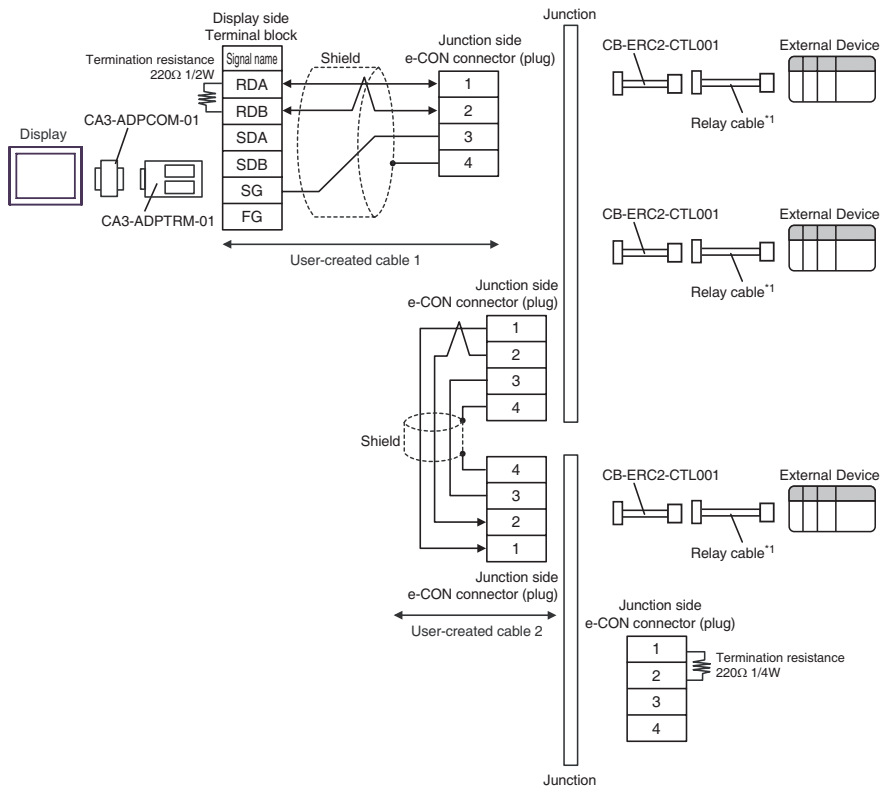

\*1 We recommend the IAI Corporation CB-ERC2-PWBIO□□□ or CB-ERC2-PWBIO□□□-RB as the relay cable.

9F)

- 1:1 connection

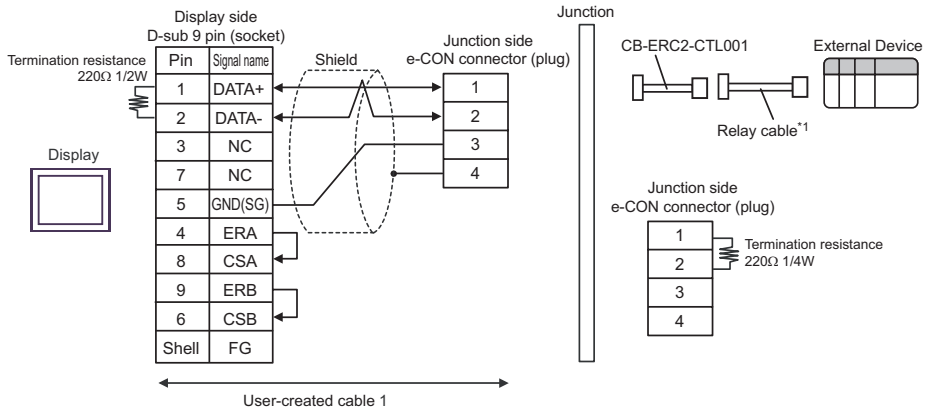

\*1 We recommend the IAI Corporation CB-ERC2-PWBIO□□□□ or CB-ERC2-PWBIO□□□□-RB as the relay cable.

- 1:n connection

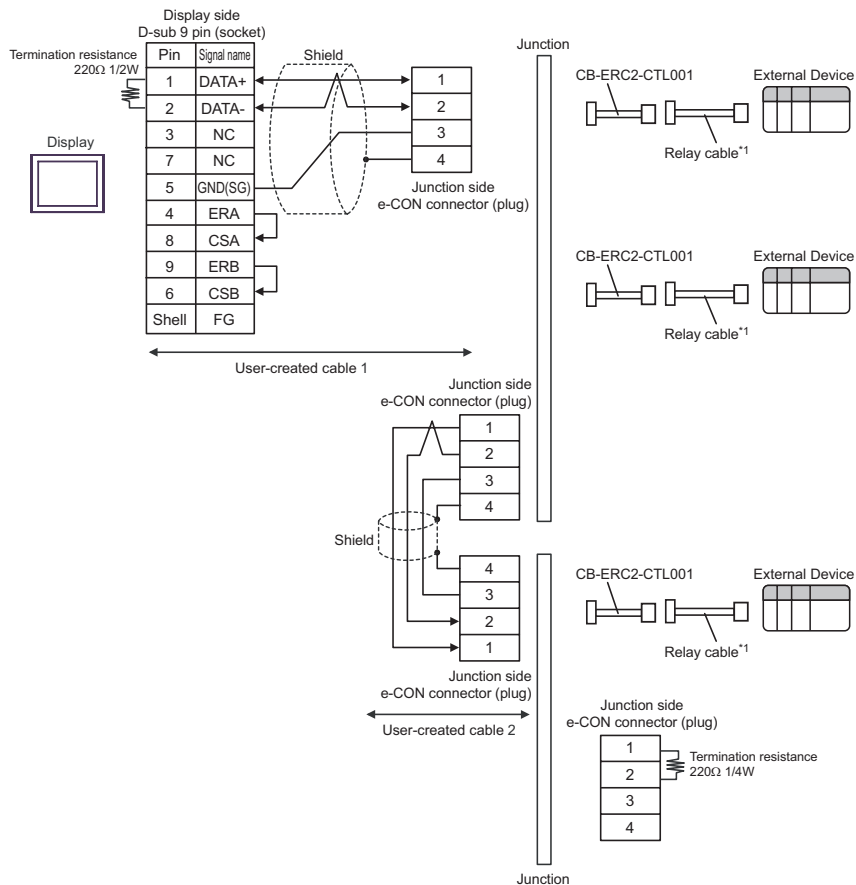

\*1 We recommend the IAI Corporation CB-ERC2-PWBIO□□□□ or CB-ERC2-PWBIO□□□□-RB as the relay cable.

9G)

- 1:1 connection

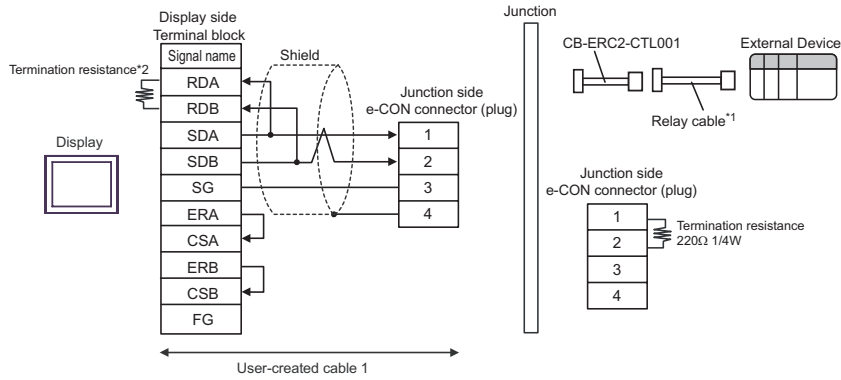

\*1 We recommend the IAI Corporation CB-ERC2-PWBIO□□□□ or CB-ERC2-PWBIO□□□□-RB as the relay cable.

\*2 The resistance in the Display is used as the termination resistance. Set the value of the DIP Switch on the rear of the Display as shown in the table below.

DIP Switch No.	Set Value
1	OFF
2	OFF
3	OFF
4	ON

- 1:n connection

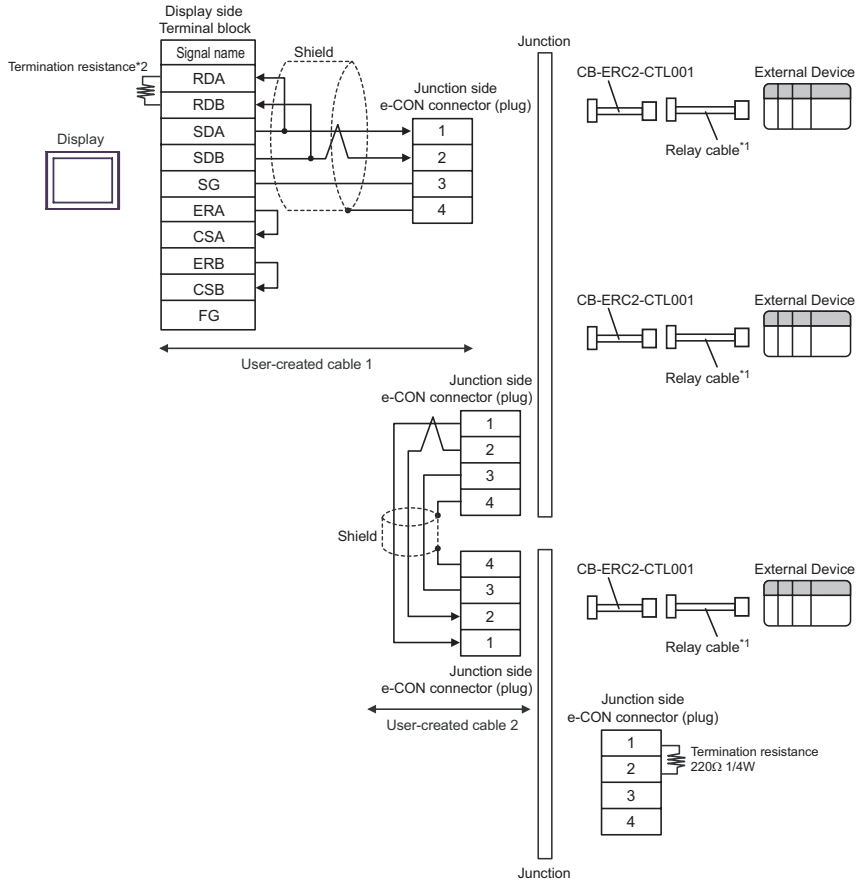

- \*1 We recommend the IAI Corporation CB-ERC2-PWBIO□□□□ or CB-ERC2-PWBIO□□□□-RB as the relay cable.
- \*2 The resistance in the Display is used as the termination resistance. Set the value of the DIP Switch on the rear of the Display as shown in the table below.

DIP Switch No.	Set Value
1	OFF
2	OFF
3	OFF
4	ON

9H)

- 1:1 connection

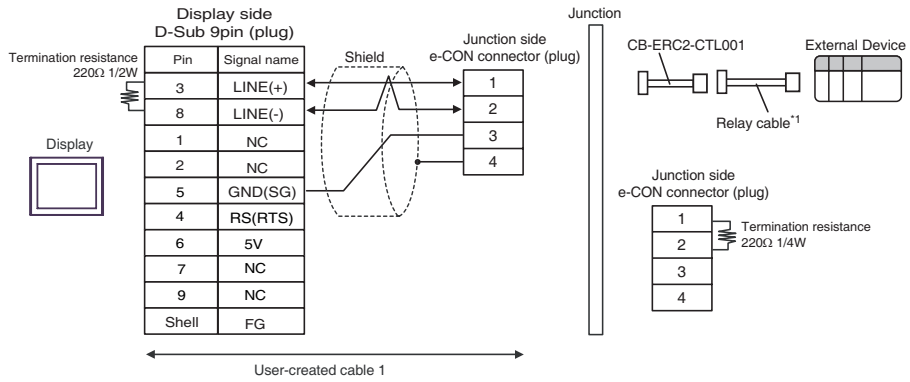

\*1 We recommend the IAI Corporation CB-ERC2-PWBIO□□□□ or CB-ERC2-PWBIO□□□□-RB as the relay cable.

• 1:n connection

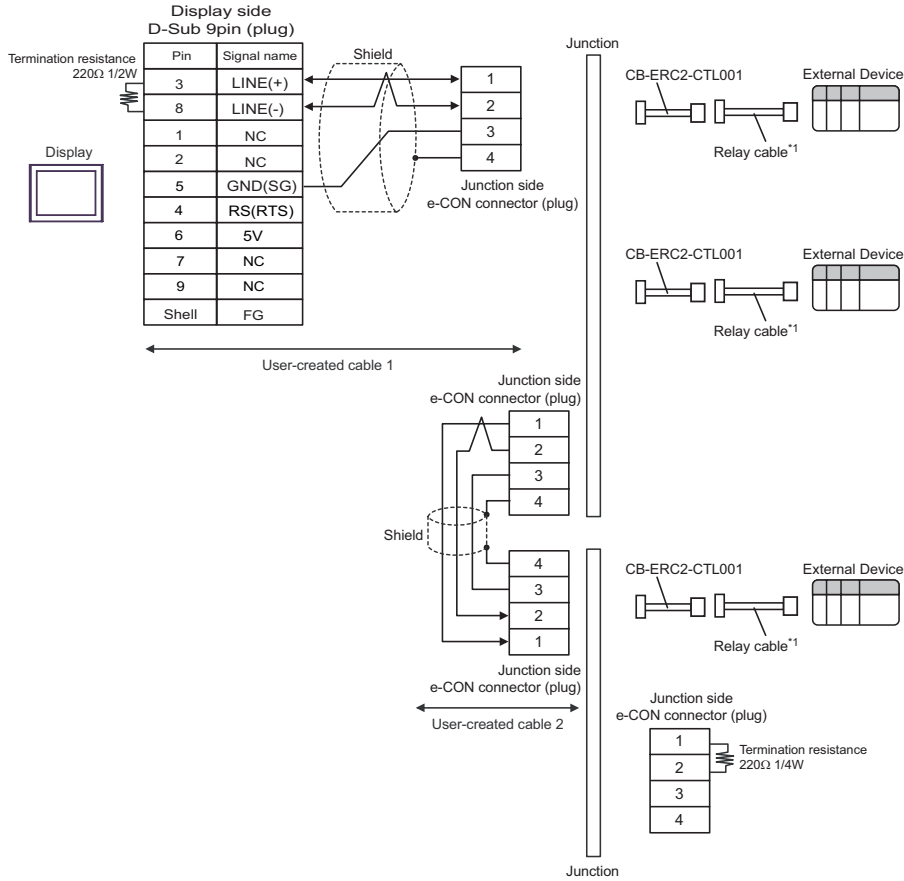

\*1 We recommend the IAI Corporation CB-ERC2-PWBIO□□□ or CB-ERC2-PWBIO□□□-RB as the relay cable.

**IMPORTANT** • The 5V output (Pin #6) on the GP-4107 is the power for the Siemens AG's PROFIBUS connector. Do not use it for other devices.

**NOTE** • In COM on the GP-4107, the SG and FG terminals are isolated.

Cable Diagram 10

Display (Connection Port)	Cable		Notes
GP3000 (COM1) ST (COM1) LT (COM1) IPC*1 PC/AT	10A	User-created cable + SIO converter by IAI Corporation RC□-TU-SIO-□ + Relay cable by IAI Corporation CB-ERC2-CTL001 + Relay cable by IAI Corporation CB-ERC2-PWBIO□□□ or CB-ERC2-PWBIO□□□-RB	Cable length from Display to SIO converter: 15m or less
	10B	User-created cable 1 + SIO converter by IAI Corporation RC□-TU-SIO-□ + User-created cable 2 + Junction by AMP*2 5-1473574-4 + Relay cable by IAI Corporation CB-ERC2-CTL001 + Relay cable by IAI Corporation CB-ERC2-PWBIO□□□ or CB-ERC2-PWBIO□□□-RB	
	10C	User-created cable 1 + SIO converter by IAI Corporation RC□-TU-SIO-□ + User-created cable 2 + Junction by AMP*2 5-1473574-4 + Relay cable by IAI Corporation CB-ERC2-CTL001 + Relay cable by IAI Corporation CB-ERC2-PWBIO□□□ or CB-ERC2-PWBIO□□□-RB	

continued to next page



Display (Connection Port)	Cable		Notes
GP-4105 (COM1)	10D	User-created cable + SIO converter by IAI Corporation RC□-TU-SIO-□ + Relay cable by IAI Corporation CB-ERC2-CTL001 + Relay cable by IAI Corporation CB-ERC2-PWBIO□□□ or CB-ERC2-PWBIO□□□-RB	Cable length from Display to SIO converter: 15m or less
	10E	User-created cable 1 + SIO converter by IAI Corporation RC□-TU-SIO-□ + User-created cable 2 + Junction by AMP*2 5-1473574-4 + Relay cable by IAI Corporation CB-ERC2-CTL001 + Relay cable by IAI Corporation CB-ERC2-PWBIO□□□ or CB-ERC2-PWBIO□□□-RB	
	10F	User-created cable 1 + SIO converter by IAI Corporation RC□-TU-SIO-□ + User-created cable 2 + Junction by AMP*2 5-1473574-4 + Relay cable by IAI Corporation CB-ERC2-CTL001 + Relay cable by IAI Corporation CB-ERC2-PWBIO□□□ or CB-ERC2-PWBIO□□□-RB	

\*1 Only the COM port which can communicate by RS-232C can be used.



\*2 When using more than one junction by AMP, user-created cable 3 is required.

**NOTE**

- When connecting to 3 or more External Devices, use link connection terminal block or junction by AMP.

10A)

- 1:1 connection

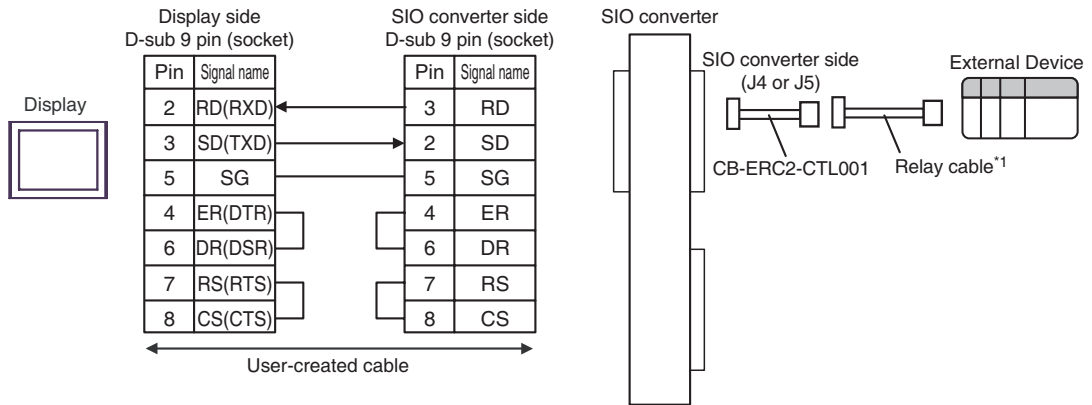

\*1 We recommend the IAI Corporation CB-ERC2-PWBIO□□□□ or CB-ERC2-PWBIO□□□□-RB as the relay cable.

- 1:n connection

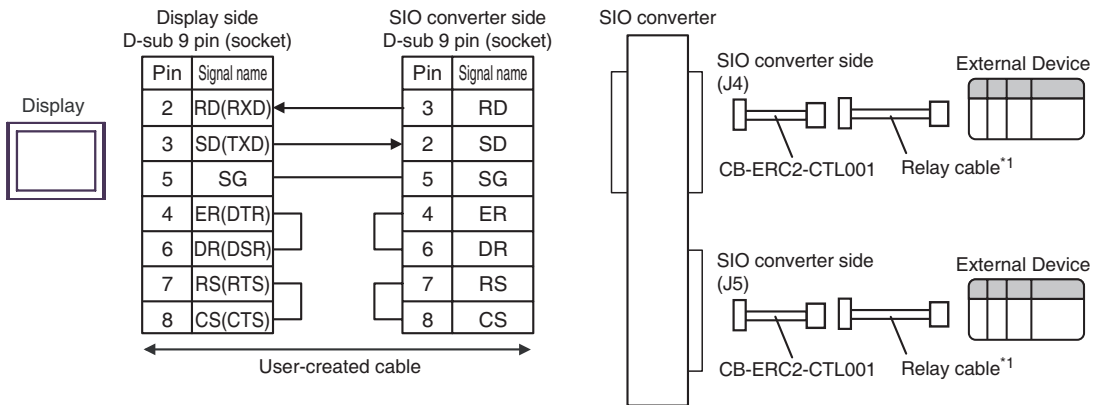

\*1 We recommend the IAI Corporation CB-ERC2-PWBIO□□□□ or CB-ERC2-PWBIO□□□□-RB as the relay cable.

10B)

- 1:1 connection

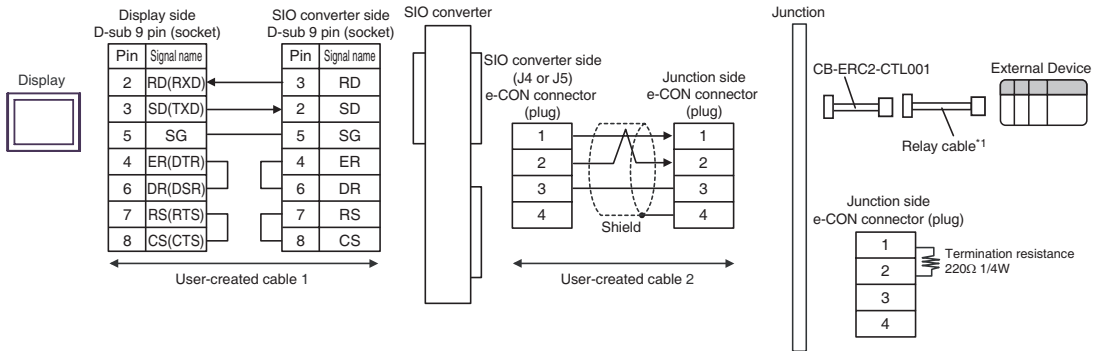

\*1 We recommend the IAI Corporation CB-ERC2-PWBIO□□□□ or CB-ERC2-PWBIO□□□□-RB as the relay cable.

- 1:n connection

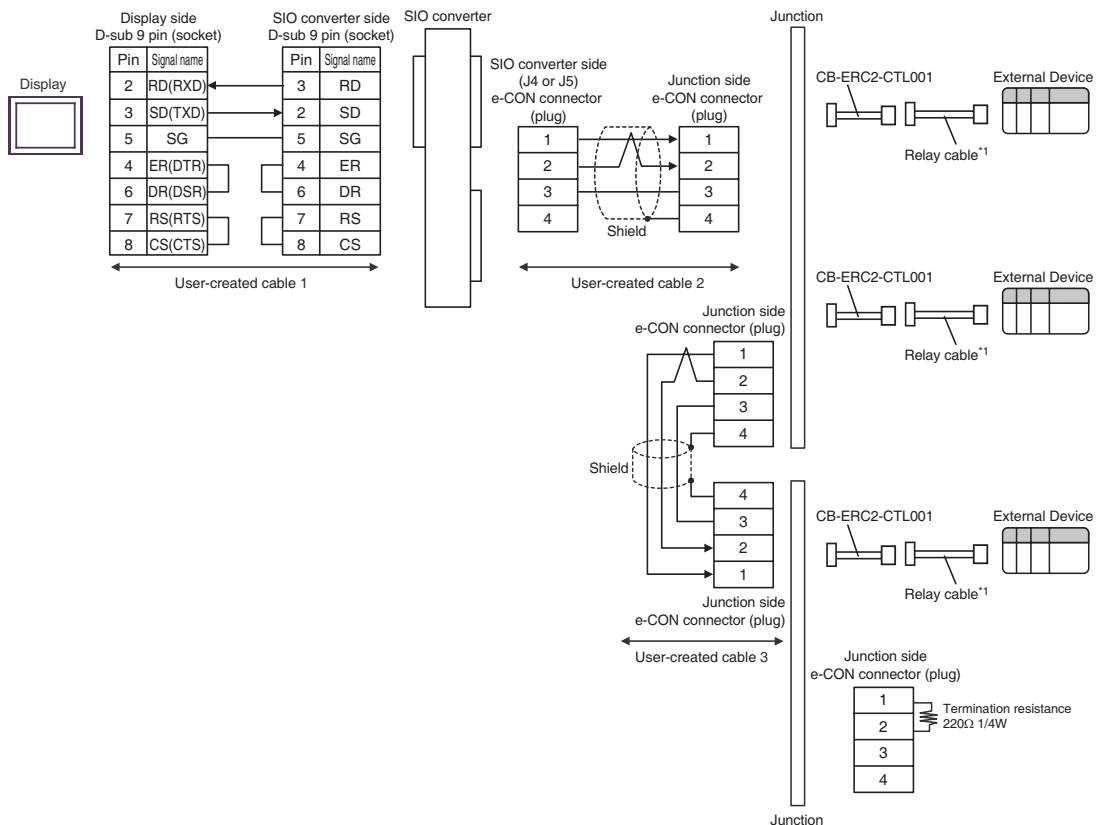

\*1 We recommend the IAI Corporation CB-ERC2-PWBIO□□□□ or CB-ERC2-PWBIO□□□□-RB as the relay cable.

10C)

• 1:1 connection

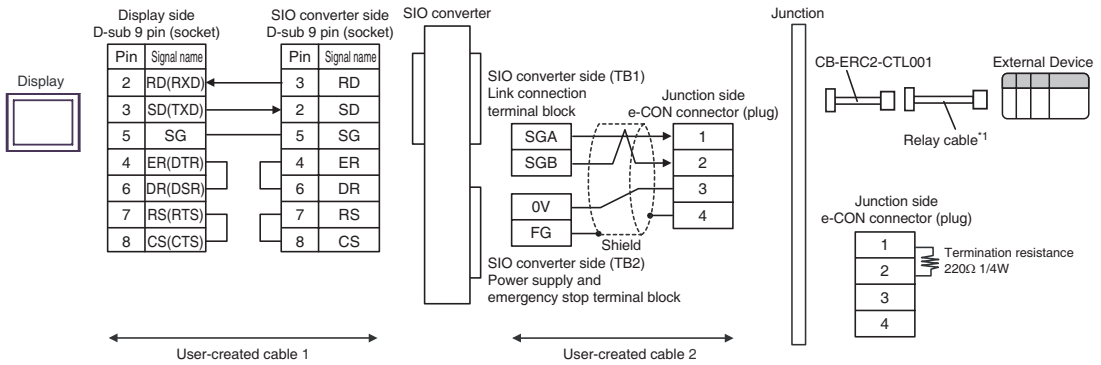

\*1 We recommend the IAI Corporation CB-ERC2-PWBIO□□□□ or CB-ERC2-PWBIO□□□□-RB as the relay cable.

• 1:n connection

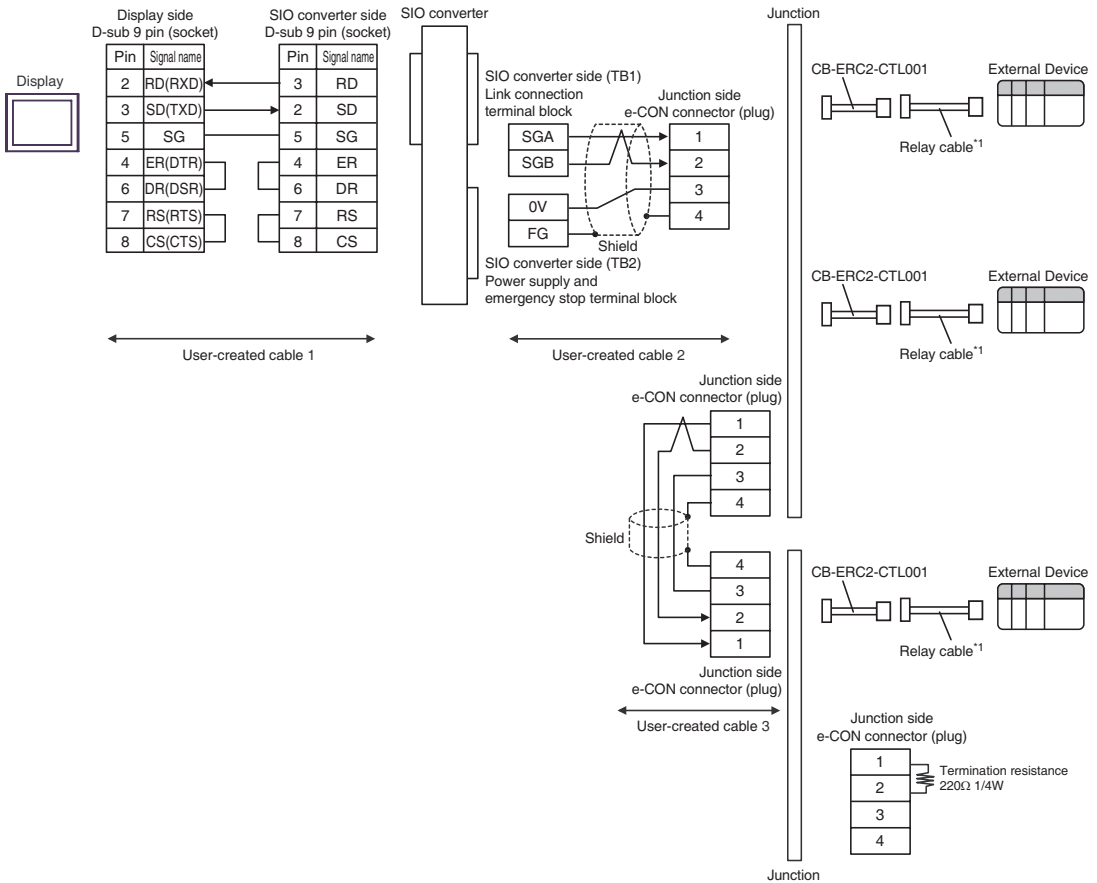

\*1 We recommend the IAI Corporation CB-ERC2-PWBIO□□□□ or CB-ERC2-PWBIO□□□□-RB as the relay cable.

10D)

- 1:1 connection

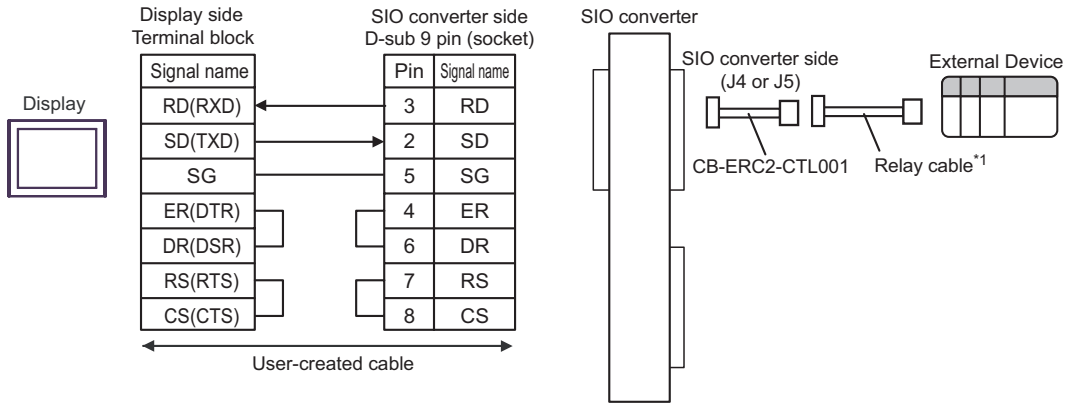

\*1 We recommend the IAI Corporation CB-ERC2-PWBIO□□□□ or CB-ERC2-PWBIO□□□□-RB as the relay cable.

- 1:n connection

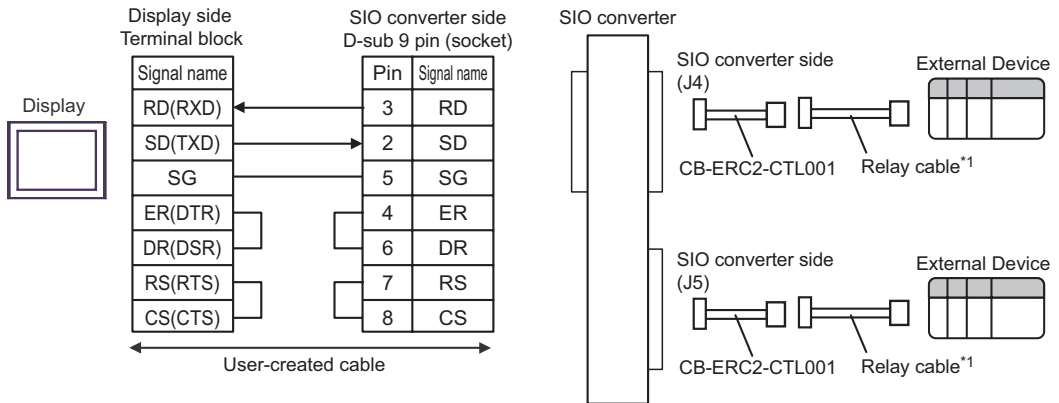

\*1 We recommend the IAI Corporation CB-ERC2-PWBIO□□□□ or CB-ERC2-PWBIO□□□□-RB as the relay cable.

10E)

- 1:1 connection

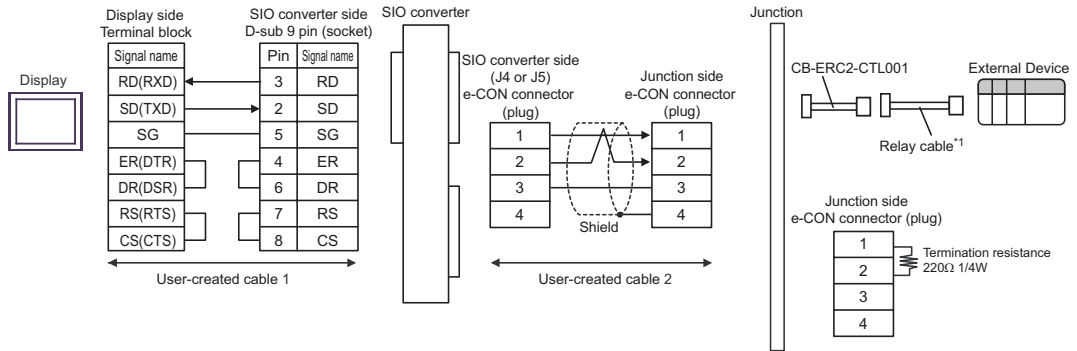

\*1 We recommend the IAI Corporation CB-ERC2-PWBIO□□□□ or CB-ERC2-PWBIO□□□□-RB as the relay cable.

- 1:n connection

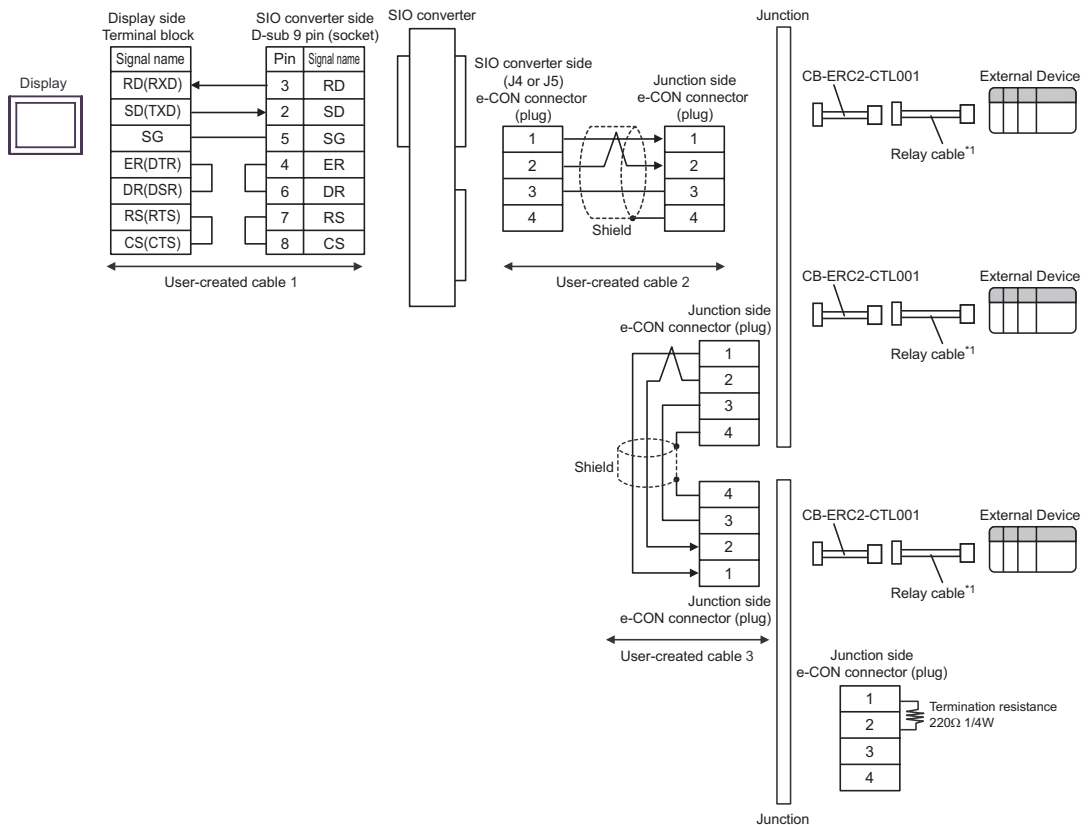

\*1 We recommend the IAI Corporation CB-ERC2-PWBIO□□□□ or CB-ERC2-PWBIO□□□□-RB as the relay cable.

10F)

• 1:1 connection

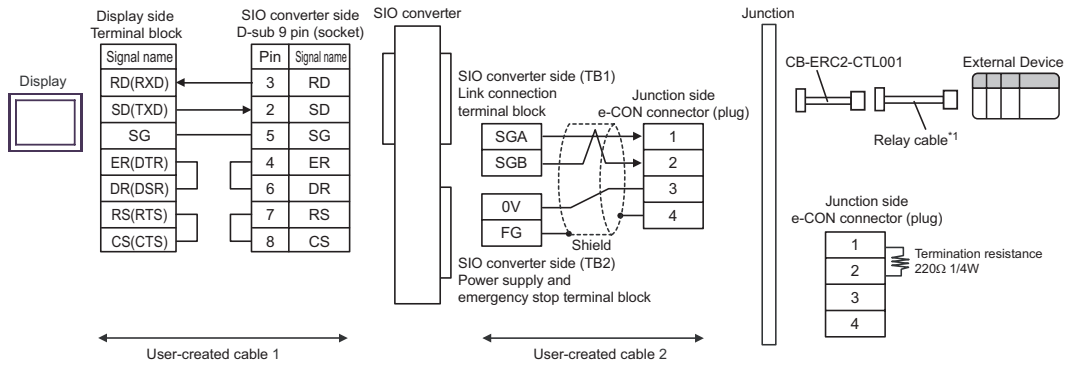

\*1 We recommend the IAI Corporation CB-ERC2-PWBIO□□□□ or CB-ERC2-PWBIO□□□□-RB as the relay cable.

• 1:n connection

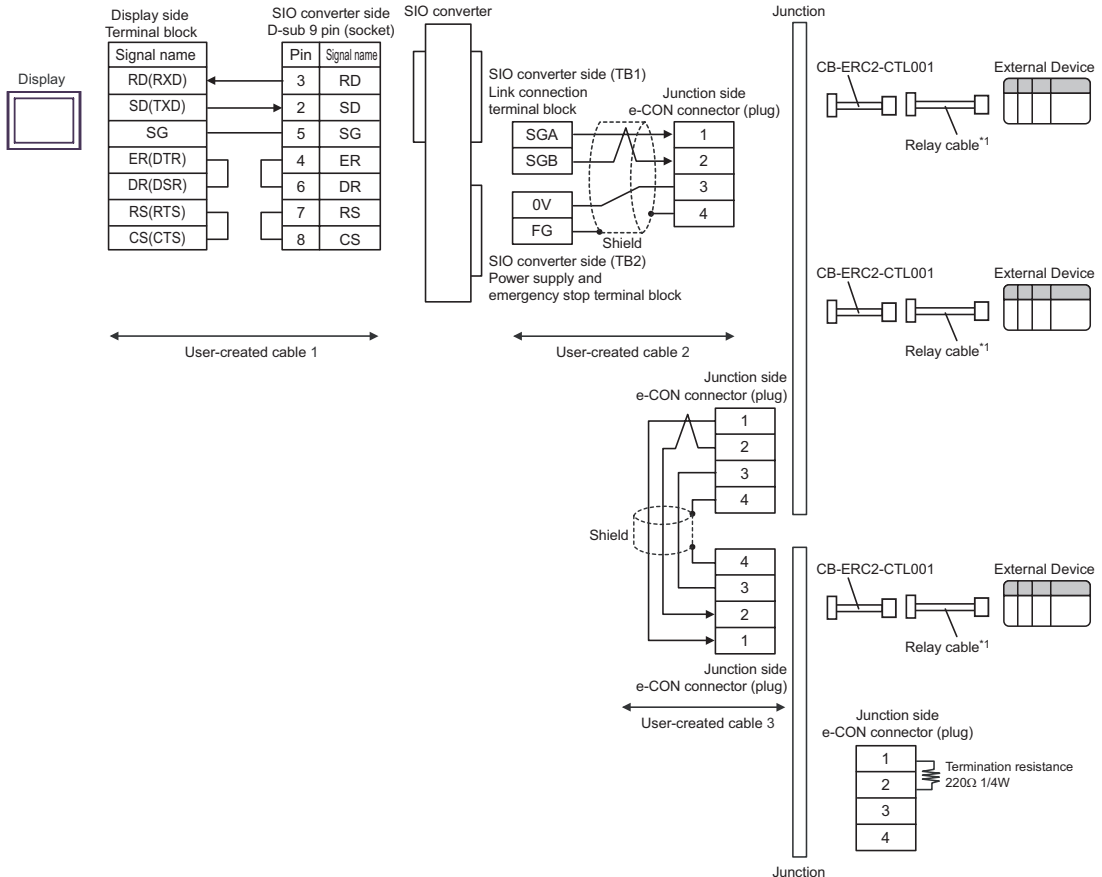

\*1 We recommend the IAI Corporation CB-ERC2-PWBIO□□□□ or CB-ERC2-PWBIO□□□□-RB as the relay cable.

Cable Diagram 11

Display (Connection Port)	Cable		Notes
GP3000 (COM1) ST (COM1) LT (COM1) IPC* <sup>1</sup> PC/AT	11A	RS232C conversion unit by IAI Corporation RCB-CV-MW + Communication cable by IAI Corporation CB-RCA-SIO050 + SIO converter by IAI Corporation RC□-TU-SIO-□ + Relay cable by IAI Corporation CB-ERC2-CTL001 + Relay cable by IAI Corporation CB-ERC2-PWBIO□□□ or CB-ERC2-PWBIO□□□-RB	Cable length from SIO converter to External Device: 100m or less
	11B	RS232C conversion unit by IAI Corporation RCB-CV-MW + Communication cable by IAI Corporation CB-RCA-SIO050 + SIO converter by IAI Corporation RC□-TU-SIO-□ + User-created cable 1 + Junction by AMP* <sup>2</sup> 5-1473574-4 + Relay cable by IAI Corporation CB-ERC2-CTL001 + Relay cable by IAI Corporation CB-ERC2-PWBIO□□□ or CB-ERC2-PWBIO□□□-RB	

continued to next page



Display (Connection Port)	Cable		Notes
GP3000 (COM1) ST (COM1) LT (COM1) IPC* <sup>1</sup> PC/AT	11C	RS232C conversion unit by IAI Corporation RCB-CV-MW + Communication cable by IAI Corporation CB-RCA-SIO050 + SIO converter by IAI Corporation RC□-TU-SIO-□ + User-created cable 1 + Junction by AMP* <sup>2</sup> 5-1473574-4 + Relay cable by IAI Corporation CB-ERC2-CTL001 + Relay cable by IAI Corporation CB-ERC2-PWBIO□□□ or CB-ERC2-PWBIO□□□-RB	Cable length from SIO converter to External Device: 100m or less
GP-4105 (COM1)	11D	User-created cable + RS232C conversion unit by IAI Corporation RCB-CV-MW + Communication cable by IAI Corporation CB-RCA-SIO050 + SIO converter by IAI Corporation RC□-TU-SIO-□ + Relay cable by IAI Corporation CB-ERC2-CTL001 + Relay cable by IAI Corporation CB-ERC2-PWBIO□□□ or CB-ERC2-PWBIO□□□-RB	

continued to next page

Display (Connection Port)	Cable		Notes
GP-4105 (COM1)	11E	User-created cable + RS232C conversion unit by IAI Corporation RCB-CV-MW + Communication cable by IAI Corporation CB-RCA-SIO050 + SIO converter by IAI Corporation RC□-TU-SIO-□ + User-created cable 1 + Junction by AMP*2 5-1473574-4 + Relay cable by IAI Corporation CB-ERC2-CTL001 + Relay cable by IAI Corporation CB-ERC2-PWBIO□□□ or CB-ERC2-PWBIO□□□-RB	Cable length from SIO converter to External Device: 100m or less
	11F	User-created cable + RS232C conversion unit by IAI Corporation RCB-CV-MW + Communication cable by IAI Corporation CB-RCA-SIO050 + SIO converter by IAI Corporation RC□-TU-SIO-□ + User-created cable 1 + Junction by AMP*2 5-1473574-4 + Relay cable by IAI Corporation CB-ERC2-CTL001 + Relay cable by IAI Corporation CB-ERC2-PWBIO□□□ or CB-ERC2-PWBIO□□□-RB	

\*1 Only the COM port which can communicate by RS-232C can be used.

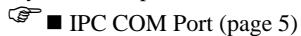

\*2 When using more than one junction by AMP, user-created cable 2 is required.

**NOTE**

- RS232C conversion unit (RCB-CV-MW) and communication cable (CB-RCA-SIO050) are accessories of PC Interface Software (RCM-101-MW) by IAI Corporation.
- When connecting to 3 or more External Devices, use link connection terminal block or junction by AMP.

11A)

- 1:1 connection

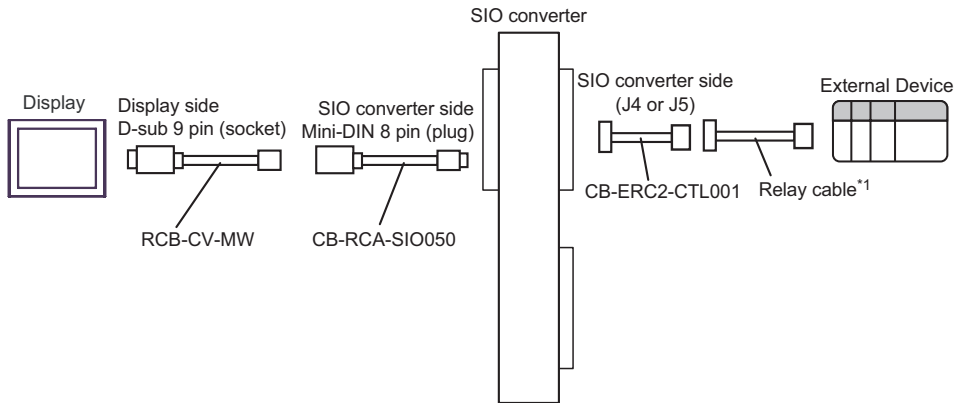

\*1 We recommend the IAI Corporation CB-ERC2-PWBIO□□□ or CB-ERC2-PWBIO□□□-RB as the relay cable.

- 1:n connection

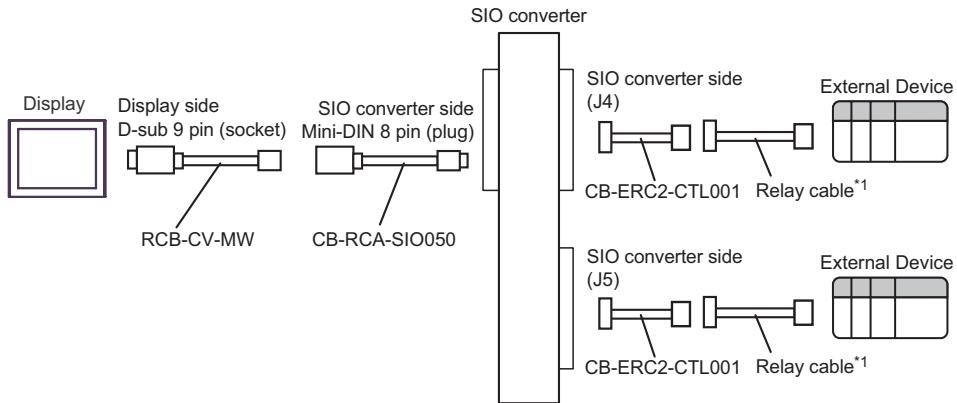

\*1 We recommend the IAI Corporation CB-ERC2-PWBIO□□□ or CB-ERC2-PWBIO□□□-RB as the relay cable.

11B)

- 1:1 connection

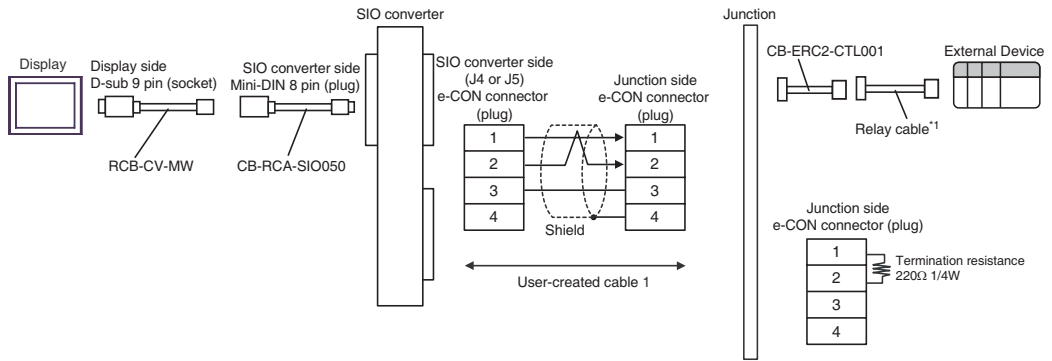

\*1 We recommend the IAI Corporation CB-ERC2-PWBIO□□□□ or CB-ERC2-PWBIO□□□□-RB as the relay cable.

- 1:n connection

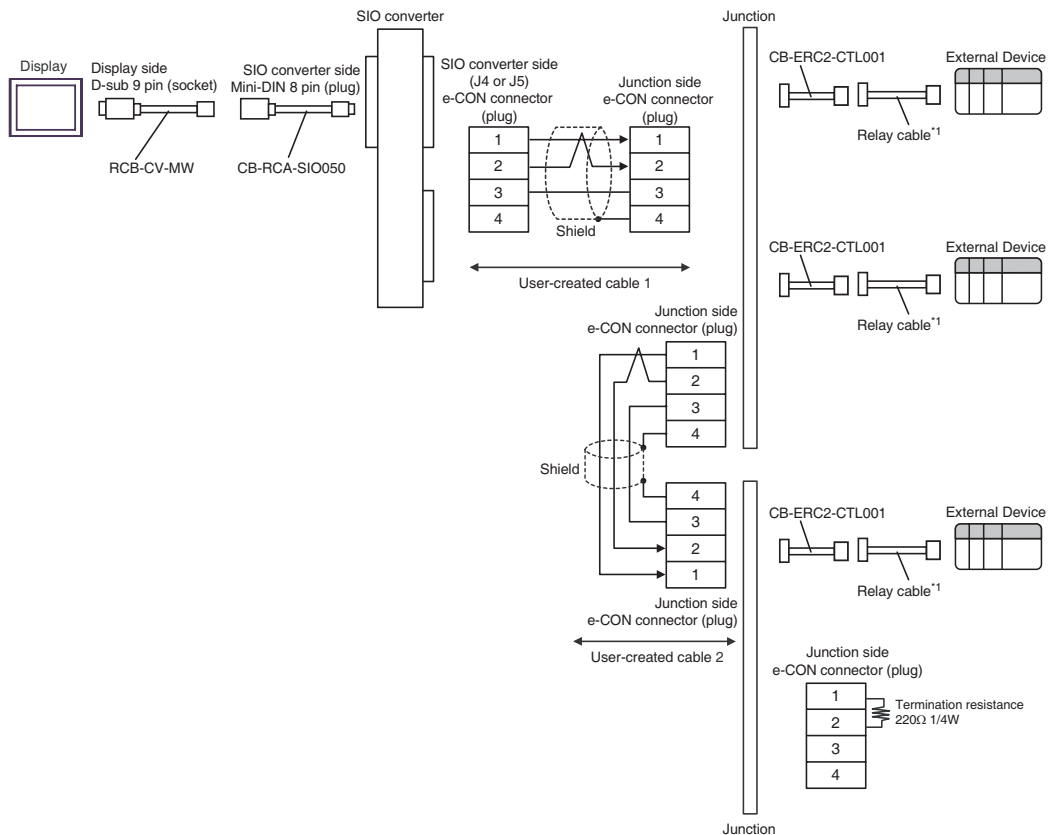

\*1 We recommend the IAI Corporation CB-ERC2-PWBIO□□□□ or CB-ERC2-PWBIO□□□□-RB as the relay cable.

11C)

- 1:1 connection

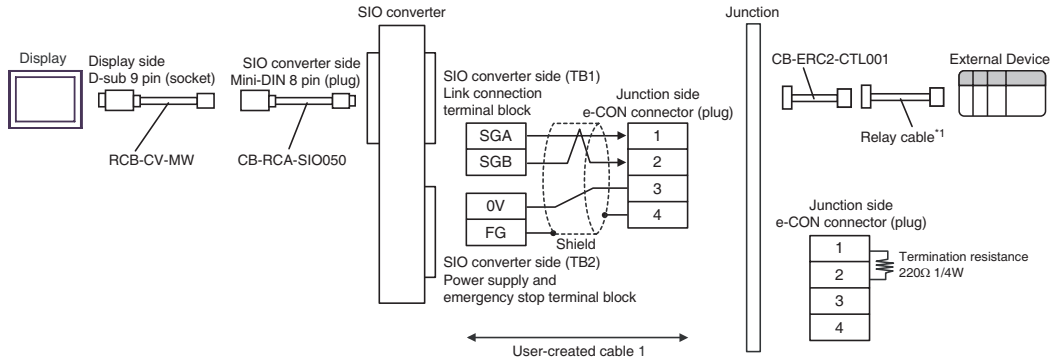

\*1 We recommend the IAI Corporation CB-ERC2-PWBIO□□□□ or CB-ERC2-PWBIO□□□□-RB as the relay cable.

- 1:n connection

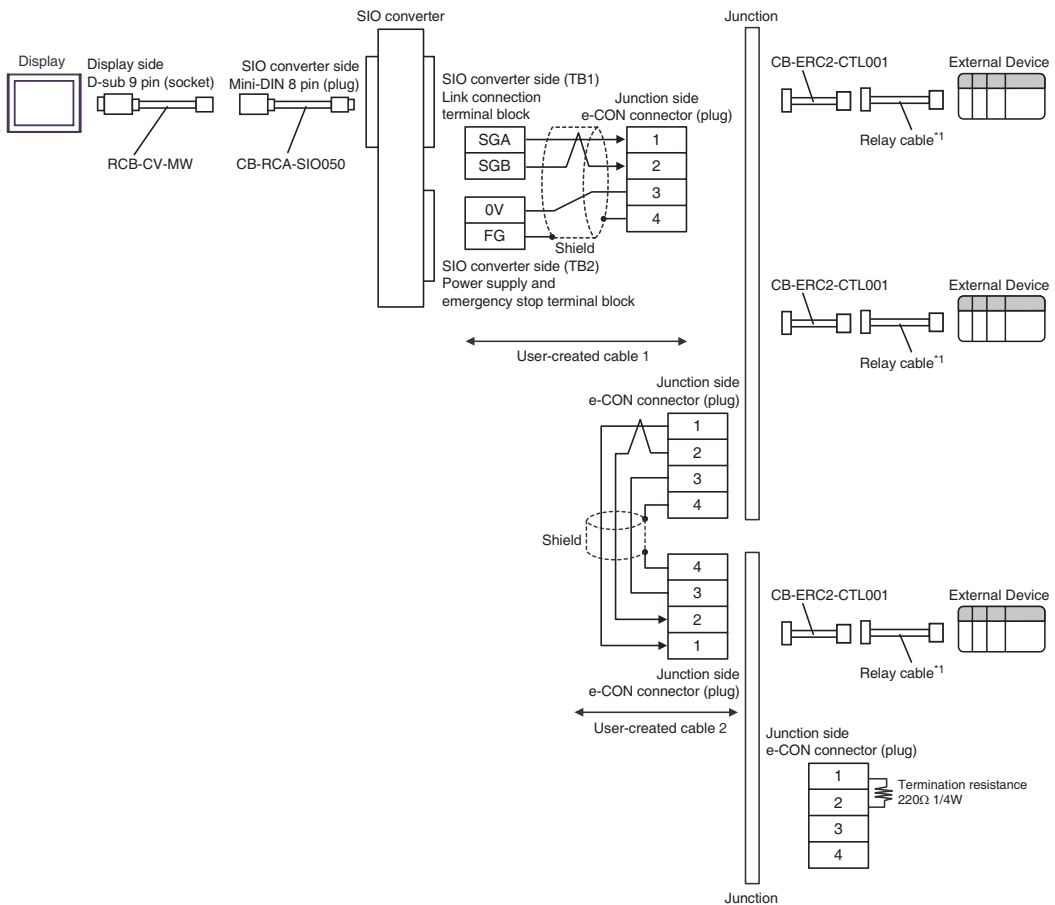

\*1 We recommend the IAI Corporation CB-ERC2-PWBIO□□□□ or CB-ERC2-PWBIO□□□□-RB as the relay cable.

11D)

- 1:1 connection

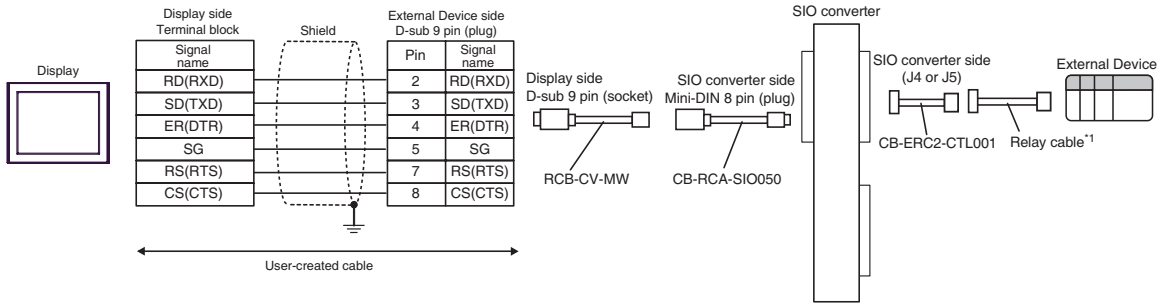

\*1 We recommend the IAI Corporation CB-ERC2-PWBIO□□□ or CB-ERC2-PWBIO□□□-RB as the relay cable.

- 1:n connection

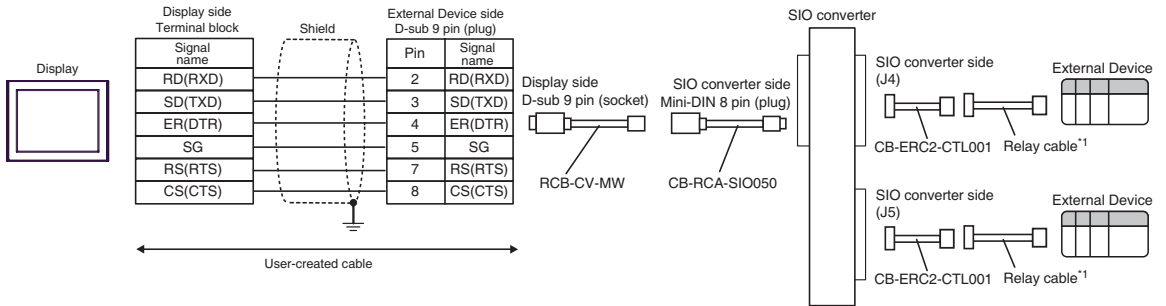

\*1 We recommend the IAI Corporation CB-ERC2-PWBIO□□□ or CB-ERC2-PWBIO□□□-RB as the relay cable.

11E)

- 1:1 connection

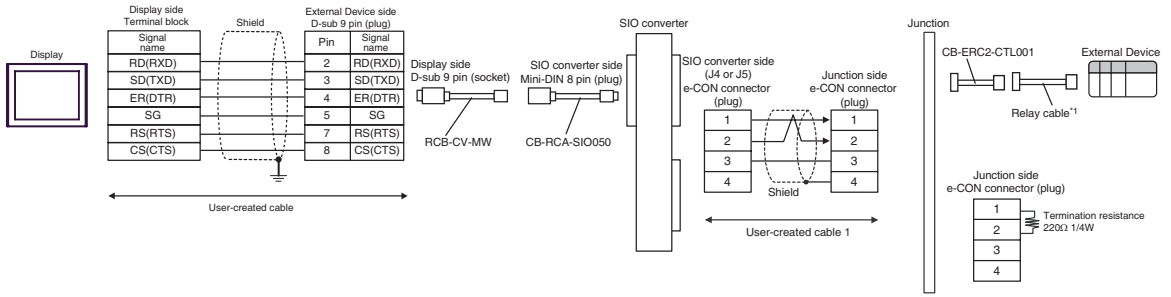

\*1 We recommend the IAI Corporation CB-ERC2-PWBIO□□□ or CB-ERC2-PWBIO□□□-RB as the relay cable.

- 1:n connection

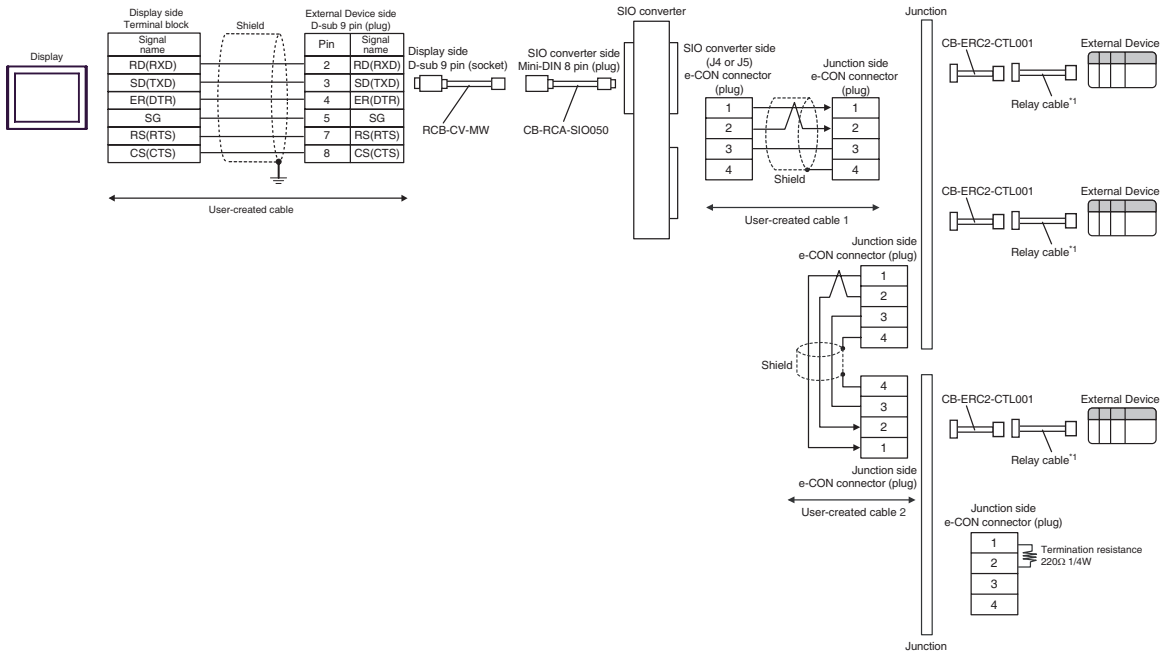

\*1 We recommend the IAI Corporation CB-ERC2-PWBIO□□□ or CB-ERC2-PWBIO□□□-RB as the relay cable.

11F)

- 1:1 connection

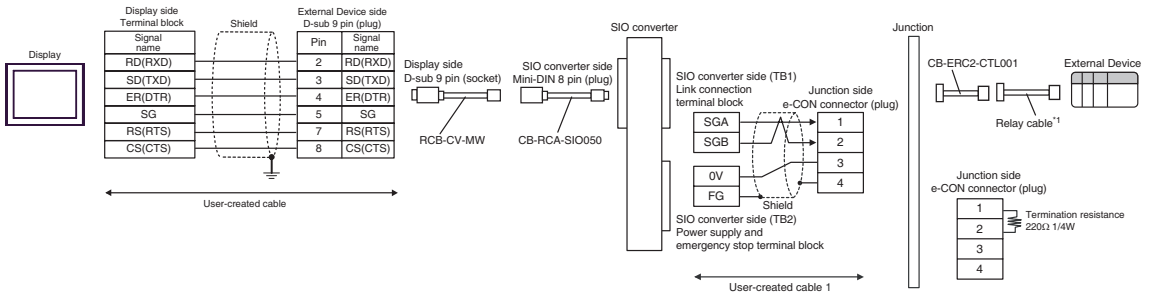

- \*1 We recommend the IAI Corporation CB-ERC2-PWBIO□□□□ or CB-ERC2-PWBIO□□□□-RB as the relay cable.

- 1:n connection

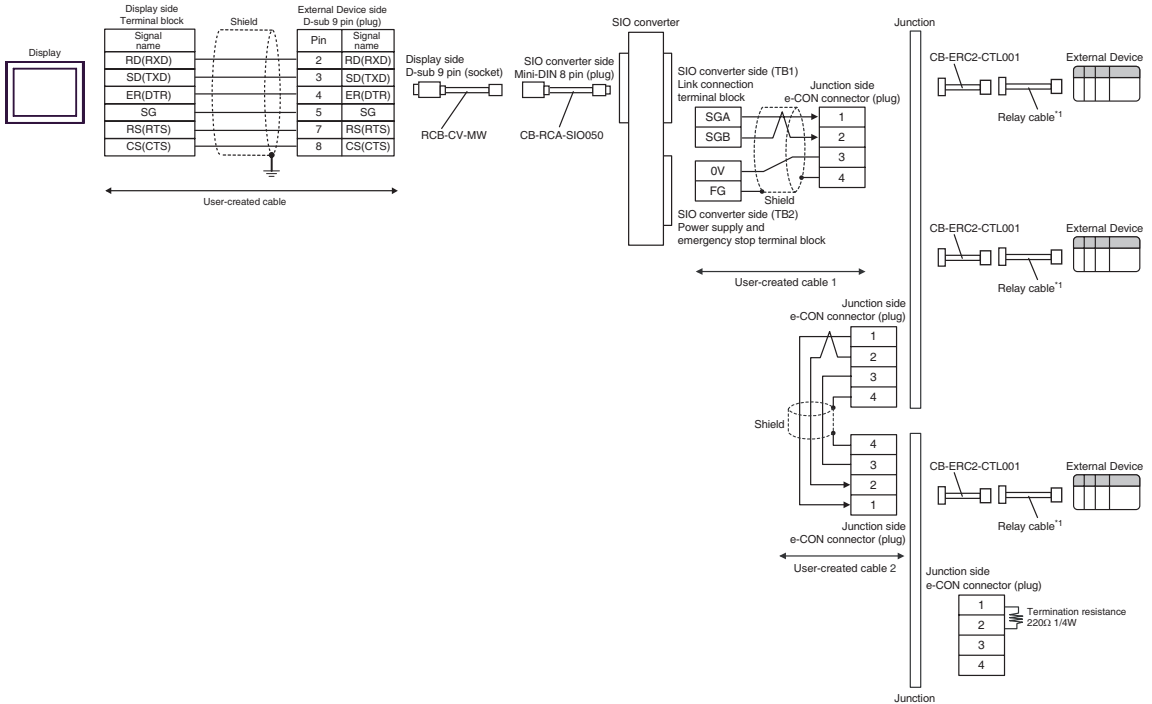

- \*1 We recommend the IAI Corporation CB-ERC2-PWBIO□□□□ or CB-ERC2-PWBIO□□□□-RB as the relay cable.



Cable Diagram 12

Display (Connection Port)	Cable		Notes
GP3000* <sup>1</sup> (COM1) AGP-3302B (COM2) ST* <sup>2</sup> (COM2) LT (COM1)	12A	COM port conversion adapter by Pro-face CA3-ADPCOM-01 + Terminal block conversion adapter by Pro-face CA3-ADPTRM-01 + User-created cable + Connector by Phoenix Contact K.K. MC1.5/4-ST-3.5	Cable length: 100m or less
	12B	User-created cable + Connector by Phoenix Contact K.K. MC1.5/4-ST-3.5	
GP3000* <sup>3</sup> (COM2)	12C	Online adapter by Pro-face CA4-ADPONL-01 + Terminal block conversion adapter by Pro-face CA3-ADPTRM-01 + User-created cable + Connector by Phoenix Contact K.K. MC1.5/4-ST-3.5	
	12D	Online adapter by Pro-face CA4-ADPONL-01 + User-created cable + Connector by Phoenix Contact K.K. MC1.5/4-ST-3.5	
IPC* <sup>4</sup>	12E	COM port conversion adapter by Pro-face CA3-ADPCOM-01 + Terminal block conversion adapter by Pro-face CA3-ADPTRM-01 + User-created cable + Connector by Phoenix Contact K.K. MC1.5/4-ST-3.5	
	12F	User-created cable + Connector by Phoenix Contact K.K. MC1.5/4-ST-3.5	

continued to next page

Display (Connection Port)	Cable		Notes
GP-4106 (COM1)	12G	User-created cable + Connector by Phoenix Contact K.K. MC1.5/4-ST-3.5	Cable length: 100m or less
GP-4107 (COM1)	12H	User-created cable + Connector by Phoenix Contact K.K. MC1.5/4-ST-3.5	

- \*1 All GP3000 models except AGP-3302B
- \*2 All ST models except AST-3211A and AST-3302B
- \*3 All GP3000 models except GP-3200 series and AGP-3302B
- \*4 Only the COM port which can communicate by RS-422/485 (2 wire) can be used.  
 ■ IPC COM Port (page 5)

12A)

- 1:1 connection

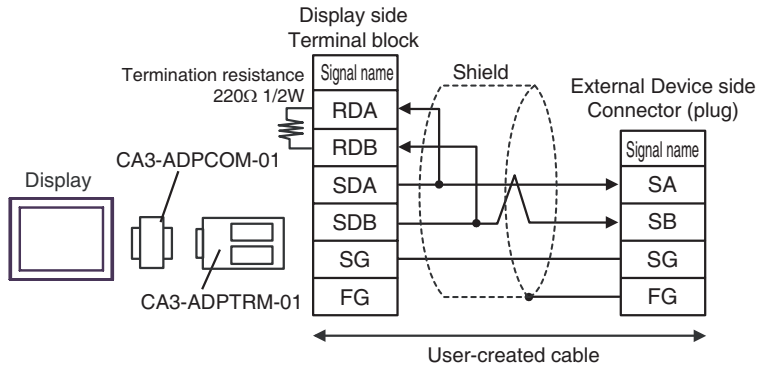

12B)

- 1:1 connection

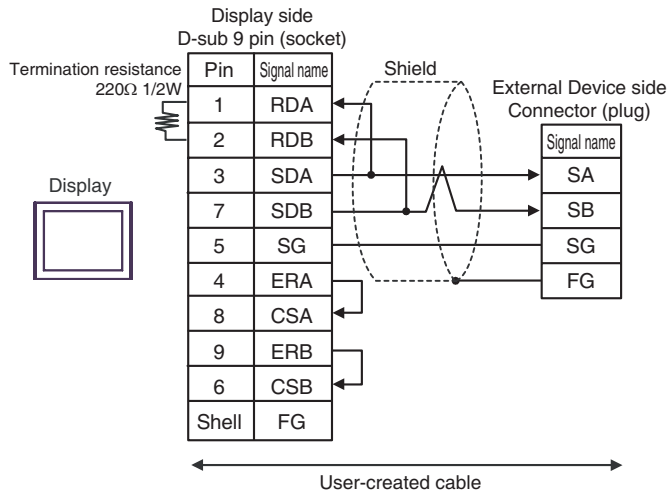

12C)

- 1:1 connection

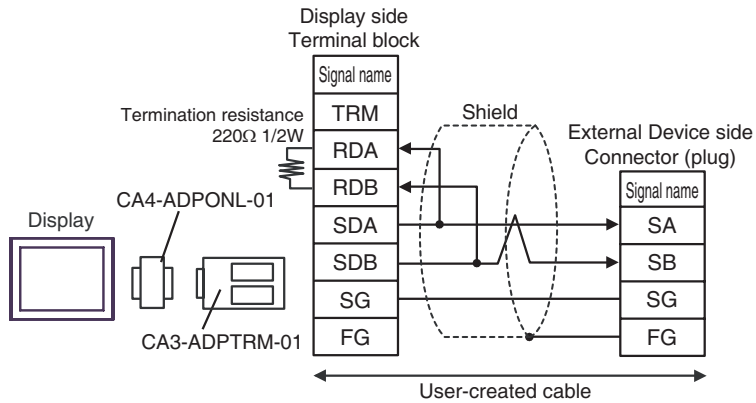

12D)

- 1:1 connection

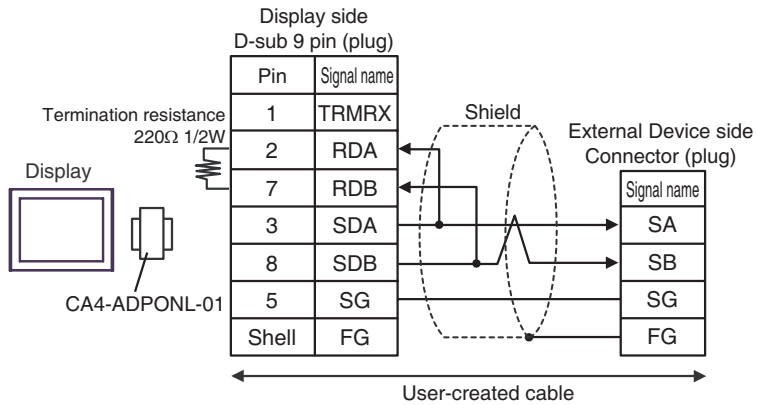

12E)

- 1:1 connection

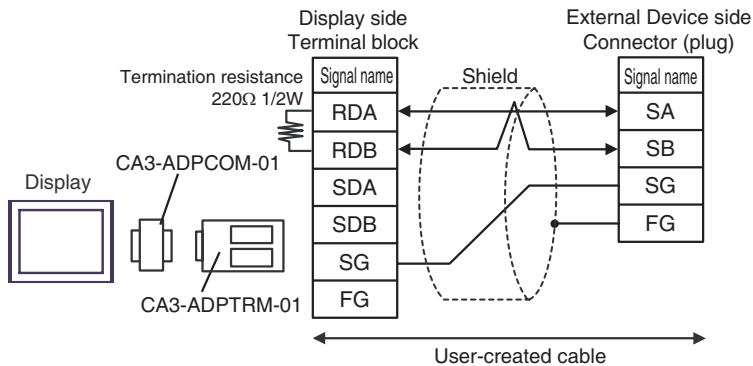

12F)

- 1:1 connection

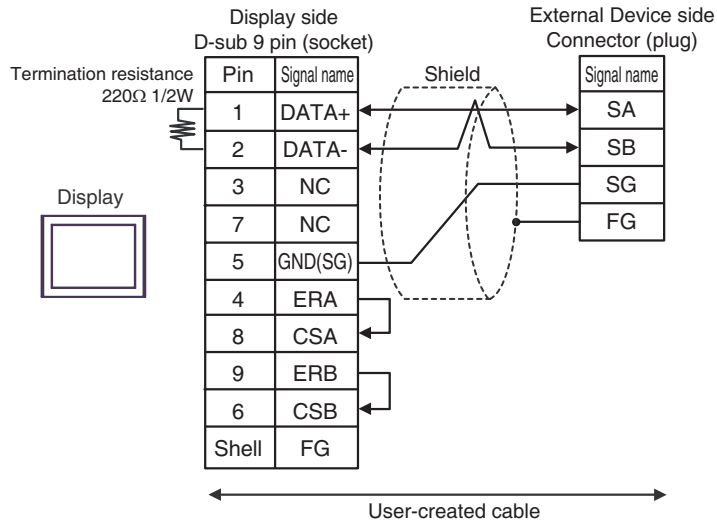

12G)

- 1:1 connection

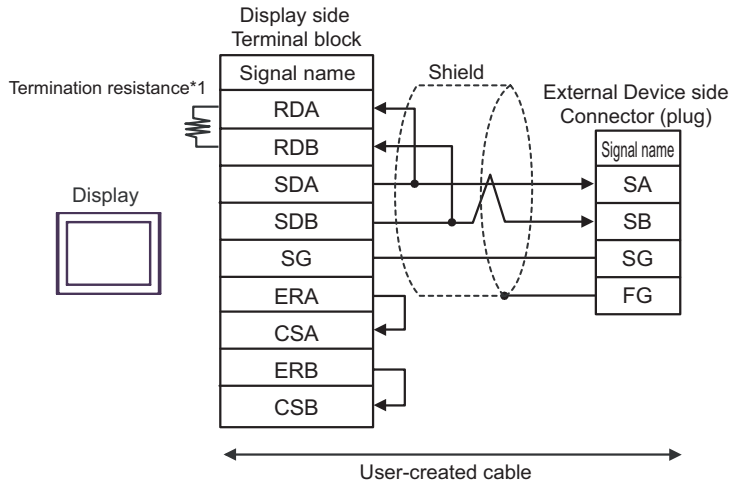

\*1 The resistance in the Display is used as the termination resistance. Set the value of the DIP Switch on the rear of the Display as shown in the table below.

DIP Switch No.	Set Value
1	OFF
2	OFF
3	OFF
4	ON

12H)

- 1:1 connection

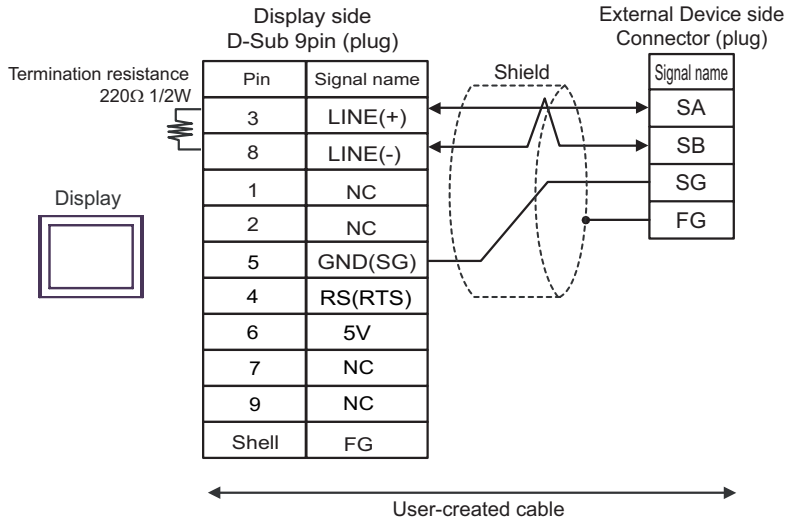

**IMPORTANT** • The 5V output (Pin #6) on the GP-4107 is the power for the Siemens AG's PROFIBUS connector. Do not use it for other devices.

**NOTE** • In COM on the GP-4107, the SG and FG terminals are isolated.

Cable Diagram 13

Display (Connection Port)	Cable		Notes
GP3000 (COM1) ST (COM1) LT (COM1) IPC <sup>*1</sup> PC/AT	13A	User-created cable 1 + SIO converter by IAI Corporation RC□-TU-SIO-□ + User-created cable 2 + Connector by Phoenix Contact K.K. MC1.5/4-ST-3.5	Cable length from Display to SIO converter: 15m or less  Cable length from SIO converter to External Device: 100m or less
	13B	User-created cable 1 + SIO converter by IAI Corporation RC□-TU-SIO-□ + User-created cable 2 + Connector by Phoenix Contact K.K. MC1.5/4-ST-3.5	
	13C	User-created cable 1 + SIO converter by IAI Corporation RC□-TU-SIO-□ + User-created cable 2 + Junction by AMP <sup>*2</sup> 5-1473574-4 + User-created cable 3 + Connector by Phoenix Contact K.K. MC1.5/4-ST-3.5	
	13D	User-created cable 1 + SIO converter by IAI Corporation RC□-TU-SIO-□ + User-created cable 2 + Junction by AMP <sup>*2</sup> 5-1473574-4 + User-created cable 3 + Connector by Phoenix Contact K.K. MC1.5/4-ST-3.5	

continued to next page

Display (Connection Port)	Cable		Notes
GP-4105 (COM1)	13E	User-created cable 1 + SIO converter by IAI Corporation RC□-TU-SIO-□ + User-created cable 2 + Connector by Phoenix Contact K.K. MC1.5/4-ST-3.5	Cable length from Display to SIO converter: 15m or less  Cable length from SIO converter to External Device: 100m or less
	13F	User-created cable 1 + SIO converter by IAI Corporation RC□-TU-SIO-□ + User-created cable 2 + Connector by Phoenix Contact K.K. MC1.5/4-ST-3.5	
	13G	User-created cable 1 + SIO converter by IAI Corporation RC□-TU-SIO-□ + User-created cable 2 + Junction by AMP*2 5-1473574-4 + User-created cable 3 + Connector by Phoenix Contact K.K. MC1.5/4-ST-3.5	
	13H	User-created cable 1 + SIO converter by IAI Corporation RC□-TU-SIO-□ + User-created cable 2 + Junction by AMP*2 5-1473574-4 + User-created cable 3 + Connector by Phoenix Contact K.K. MC1.5/4-ST-3.5	

\*1 Only the COM port which can communicate by RS-232C can be used.

 ■ IPC COM Port (page 5)

\*2 When using more than one junction by AMP, user-created cable 4 is required.

**NOTE**

- When connecting to 3 or more External Devices, use link connection terminal block or junction by AMP.

13A)

- 1:1 connection

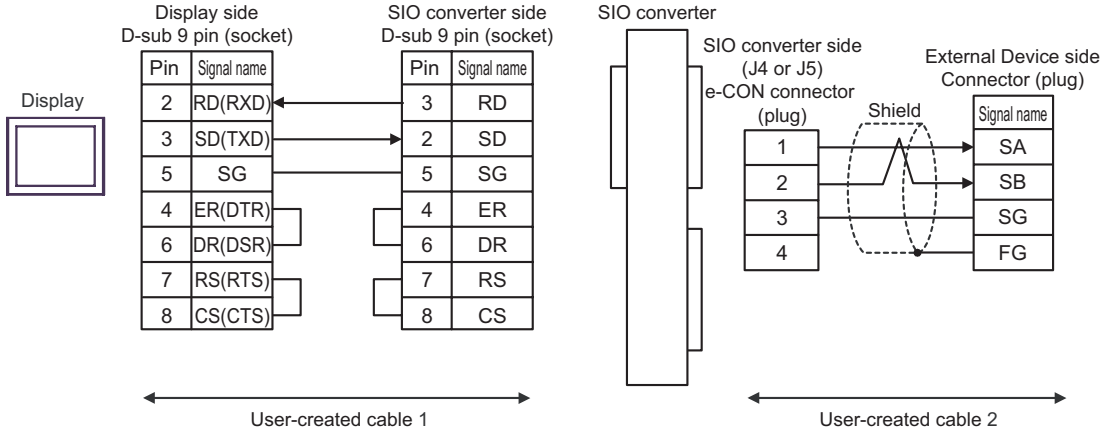

13B)

- 1:1 connection

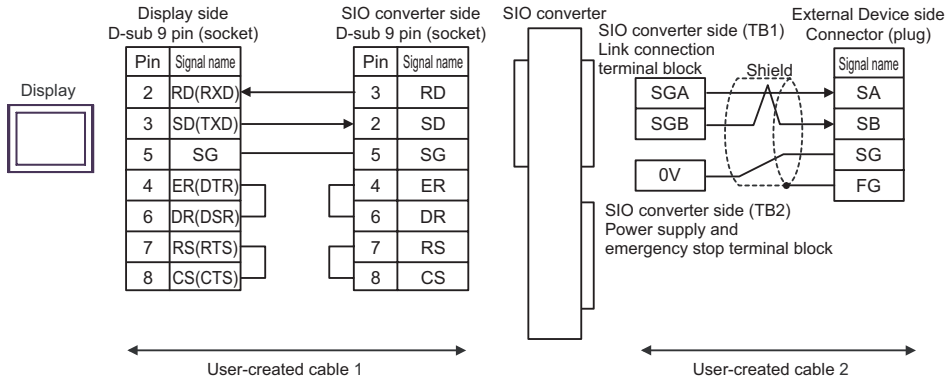



13C)

- 1:1 connection

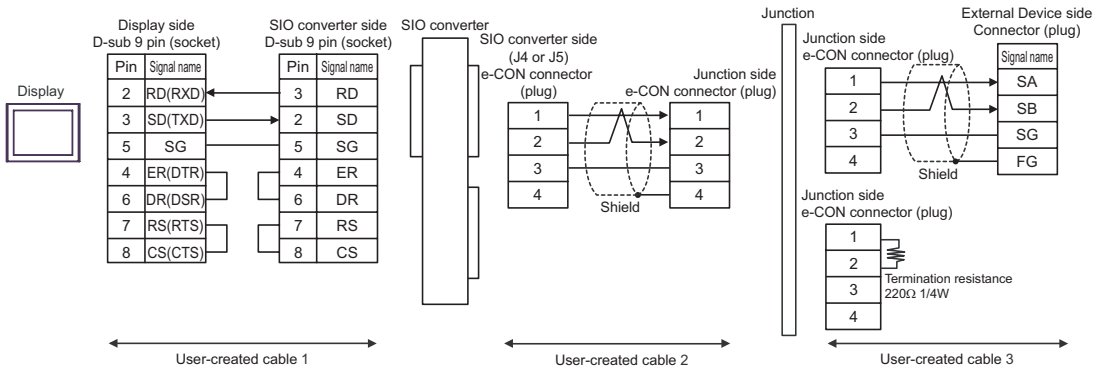

13D)

- 1:1 connection

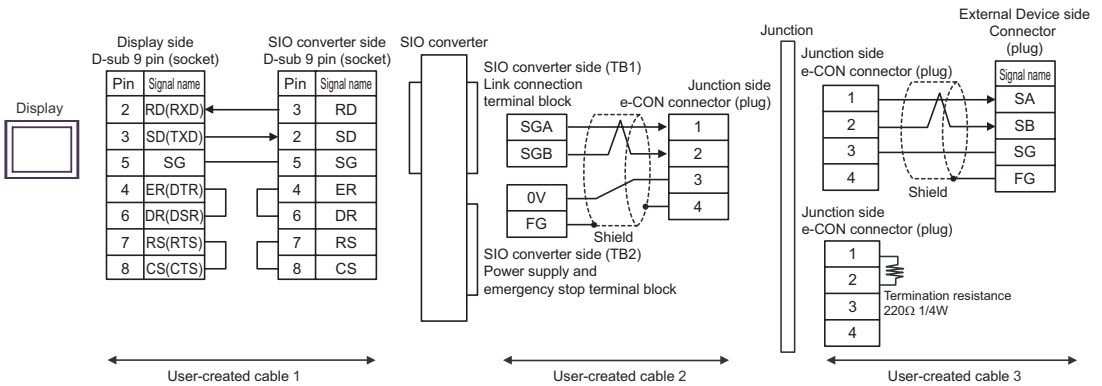

13E)

- 1:1 connection

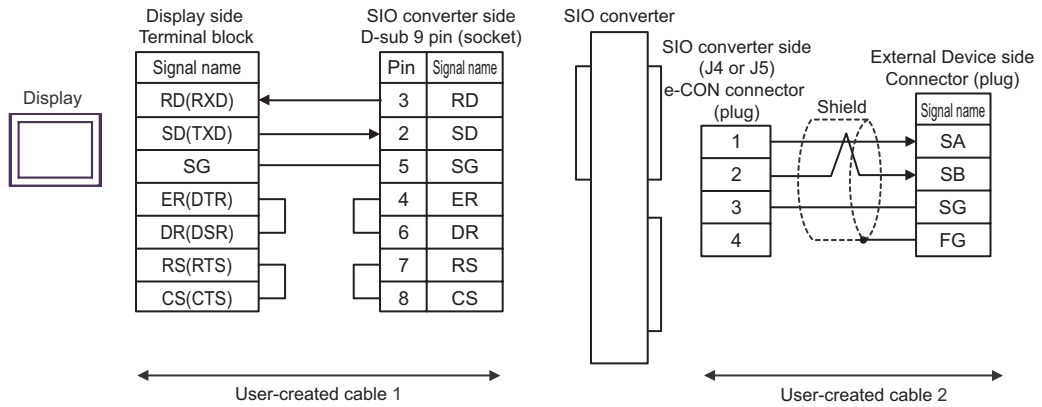

13F)

- 1:1 connection

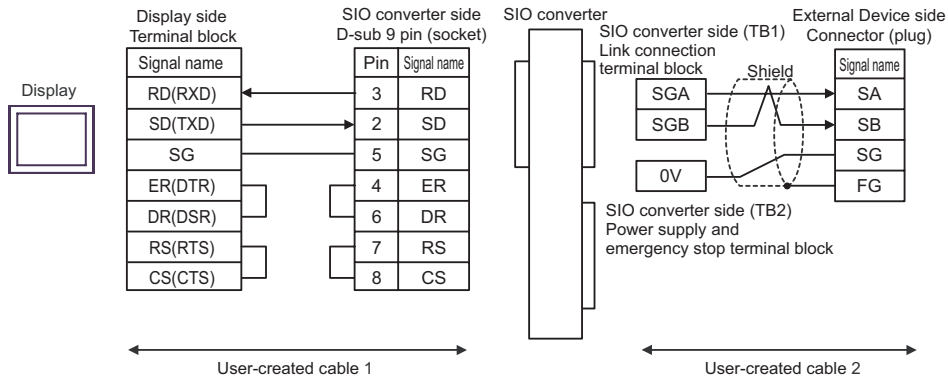

13G)

- 1:1 connection

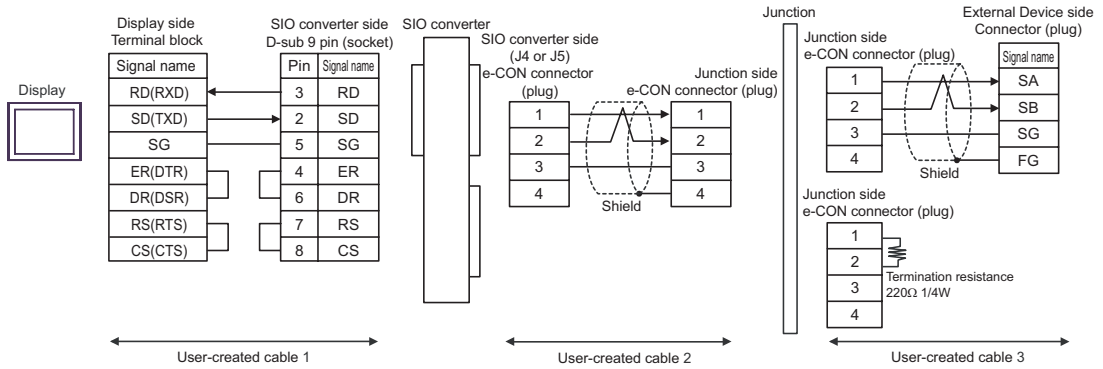

13H)

- 1:1 connection

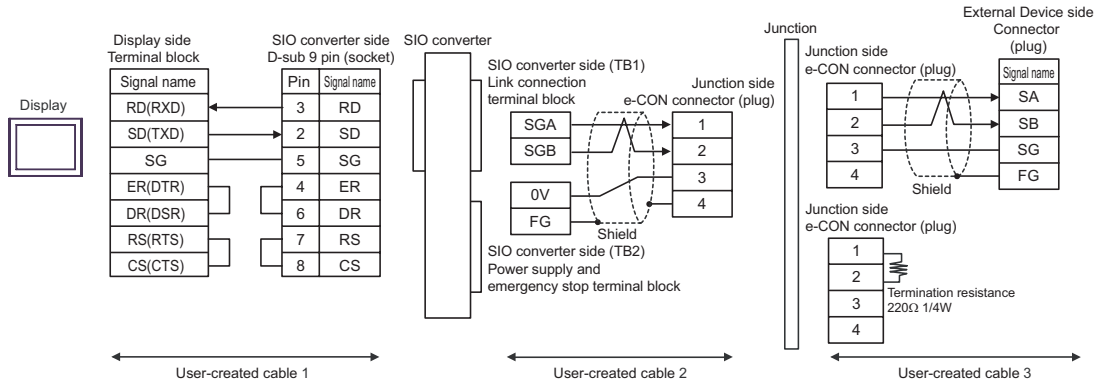

Cable Diagram 14

Display (Connection Port)	Cable		Notes
GP3000 (COM1) ST (COM1) LT (COM1) IPC*1 PC/AT	14A	RS232C conversion unit by IAI Corporation RCB-CV-MW + Communication cable by IAI Corporation CB-RCA-SIO050 + SIO converter by IAI Corporation RC□-TU-SIO-□ + User-created cable + Connector by Phoenix Contact K.K. MC1.5/4-ST-3.5	Cable length from SIO converter to External Device: 100m or less
	14B	RS232C conversion unit by IAI Corporation RCB-CV-MW + Communication cable by IAI Corporation CB-RCA-SIO050 + SIO converter by IAI Corporation RC□-TU-SIO-□ + User-created cable + Connector by Phoenix Contact K.K. MC1.5/4-ST-3.5	
	14C	RS232C conversion unit by IAI Corporation RCB-CV-MW + Communication cable by IAI Corporation CB-RCA-SIO050 + SIO converter by IAI Corporation RC□-TU-SIO-□ + User-created cable 1 + Junction by AMP*2 5-1473574-4 + User-created cable 2 + Connector by Phoenix Contact K.K. MC1.5/4-ST-3.5	

continued to next page

Display (Connection Port)	Cable		Notes
GP3000 (COM1) ST (COM1) LT (COM1) IPC*1 PC/AT	14D	RS232C conversion unit by IAI Corporation RCB-CV-MW + Communication cable by IAI Corporation CB-RCA-SIO050 + SIO converter by IAI Corporation RC□-TU-SIO-□ + User-created cable 1 + Junction by AMP*2 5-1473574-4 + User-created cable 2 + Connector by Phoenix Contact K.K. MC1.5/4-ST-3.5	
GP-4105 (COM1)	14E	User-created cable + RS232C conversion unit by IAI Corporation RCB-CV-MW + Communication cable by IAI Corporation CB-RCA-SIO050 + SIO converter by IAI Corporation RC□-TU-SIO-□ + User-created cable + Connector by Phoenix Contact K.K. MC1.5/4-ST-3.5	Cable length from SIO converter to External Device: 100m or less
	14F	User-created cable + RS232C conversion unit by IAI Corporation RCB-CV-MW + Communication cable by IAI Corporation CB-RCA-SIO050 + SIO converter by IAI Corporation RC□-TU-SIO-□ + User-created cable + Connector by Phoenix Contact K.K. MC1.5/4-ST-3.5	

continued to next page

Display (Connection Port)	Cable		Notes
GP-4105 (COM1)	14G	User-created cable + RS232C conversion unit by IAI Corporation RCB-CV-MW + Communication cable by IAI Corporation CB-RCA-SIO050 + SIO converter by IAI Corporation RC□-TU-SIO-□ + User-created cable 1 + Junction by AMP*2 5-1473574-4 + User-created cable 2 + Connector by Phoenix Contact K.K. MC1.5/4-ST-3.5	Cable length from SIO converter to External Device: 100m or less
	14H	User-created cable + RS232C conversion unit by IAI Corporation RCB-CV-MW + Communication cable by IAI Corporation CB-RCA-SIO050 + SIO converter by IAI Corporation RC□-TU-SIO-□ + User-created cable 1 + Junction by AMP*2 5-1473574-4 + User-created cable 2 + Connector by Phoenix Contact K.K. MC1.5/4-ST-3.5	

\*1 Only the COM port which can communicate by RS-232C can be used.

 ■ IPC COM Port (page 5)

\*2 When using more than one junction by AMP, user-created cable 3 is required.

**NOTE**

- RS232C conversion unit (RCB-CV-MW) and communication cable (CB-RCA-SIO050) are accessories of PC Interface Software (RCM-101-MW) by IAI Corporation.
- When connecting to 3 or more External Devices, use link connection terminal block or junction by AMP.

14A)

- 1:1 connection

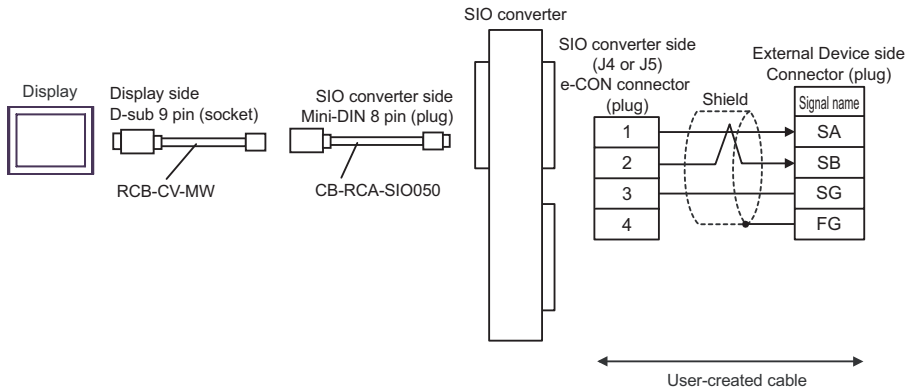

14B)

- 1:1 connection

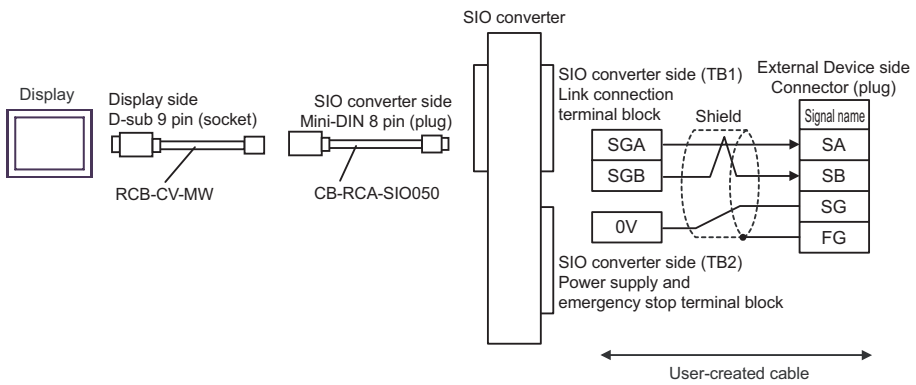

14C)

- 1:1 connection

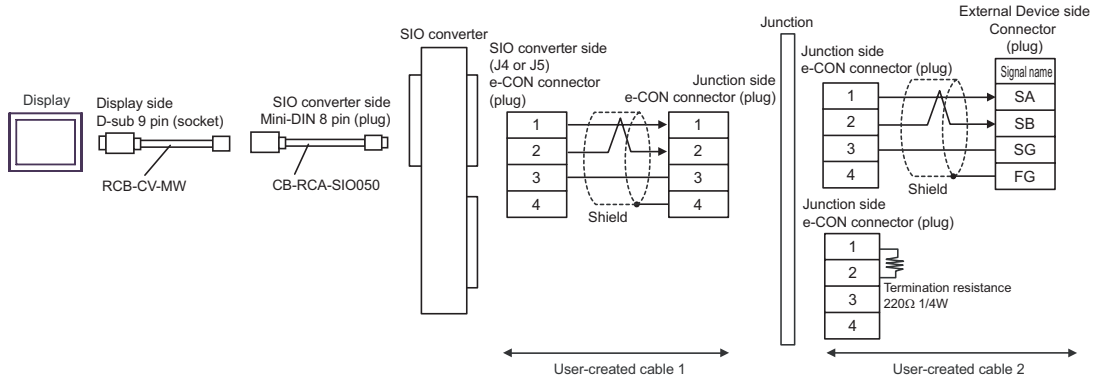

14D)

- 1:1 connection

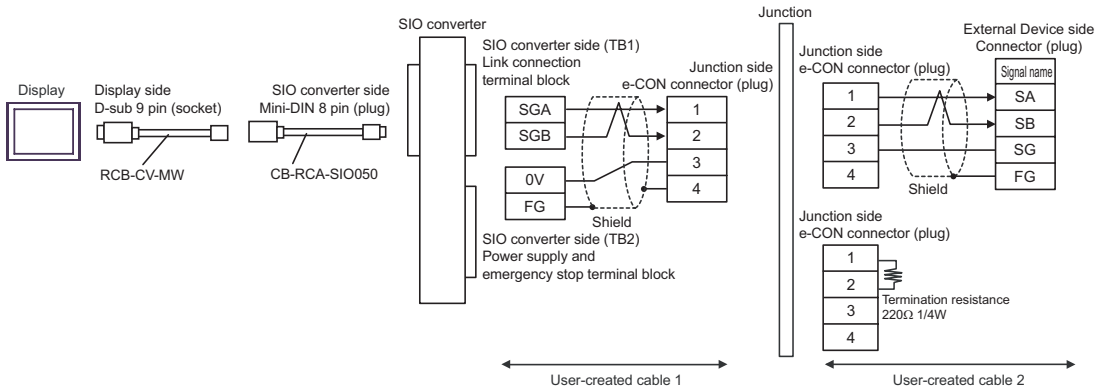



14E)

- 1:1 connection

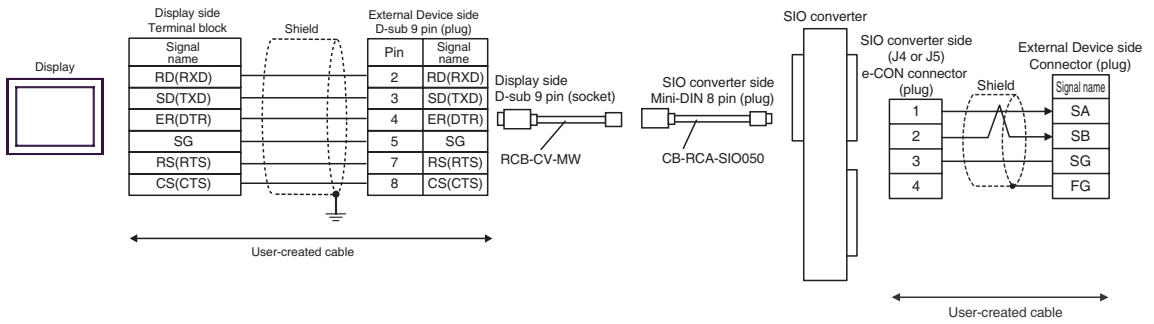

14F)

- 1:1 connection

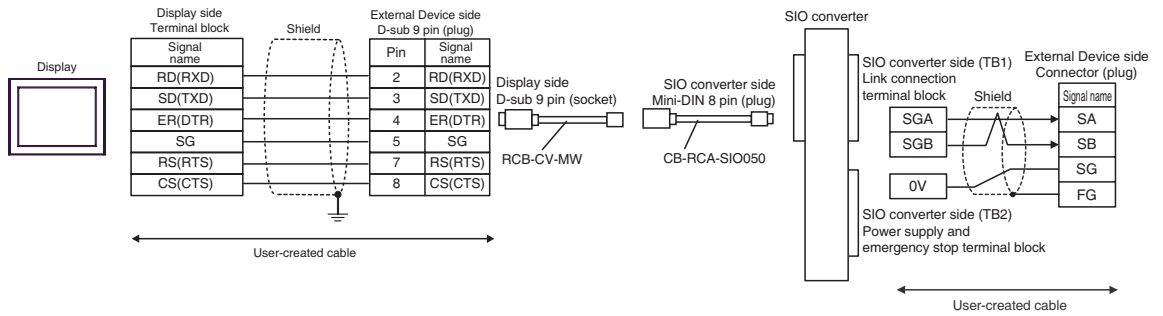

14G)

- 1:1 connection

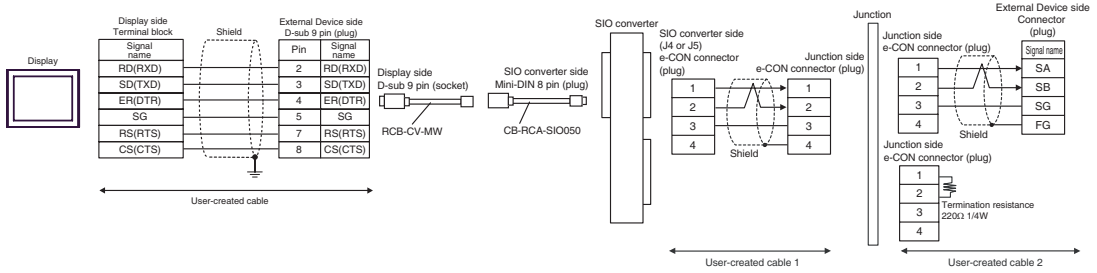

14H)

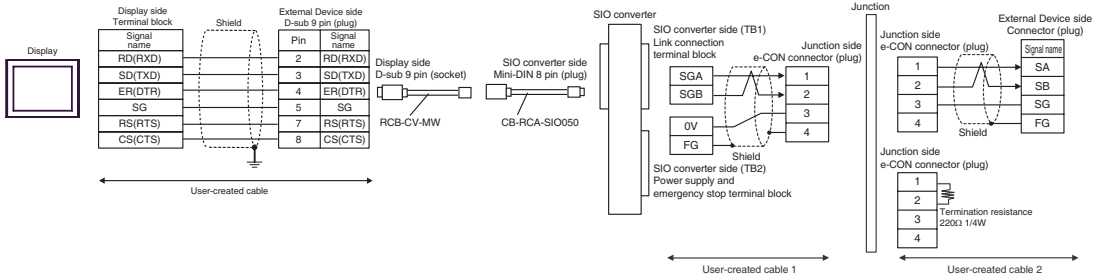

- 1:1 connection



## 6 Supported Device

Range of supported device address is shown in the table below.

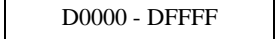
 This address can be specified as system data area.

Device	Bit Address	Word Address	32bits	Notes
Data register	D0000,00 - DFFFF,15	 D0000 - DFFFF		*1*2
Status register	S0000 - SFFFF	S0000 - SFFF0		

- \*1 System status register (D9008) in the data register has an area for 2 words. When accessing D9008 on the Display, you need to access separately both from the upper and lower words.  
e.g. When accessing the 16th bit, assign "D9008,00" on the Display. In the same way, when accessing the 0 bit, assign "D9009,00."
- \*2 Once a bit is written, the Display reads the corresponding word address of the External Device, sets the bit to the read-in word address, and returns it to the External Device. While the Display reads data of the External Device and returns the data, if the writing process is conducted with the word address ladder program, data may not be written correctly.

### NOTE

- Please refer to the GP-Pro EX Reference Manual for system data area.  
Cf. GP-Pro EX Reference Manual "LS Area (Direct Access Method)"
- Please refer to the precautions on manual notation for icons in the table.  
 "Manual Symbols and Terminology"

## 7 Device Code and Address Code

Use device code and address code when you select "Device Type & Address" for the address type in data displays.

Device	Device Name	Device Code (HEX)	Address Code
Data register	D	0000	Word Address
Status register	S	0080	Value of word address divided by 16

## 8 Error Messages

Error messages are displayed on the screen of Display as follows: "No. : Device Name: Error Message (Error Occurrence Area)". Each description is shown below.

Item	Description
No.	Error No.
Device Name	Name of External Device where error occurs. Device name is a title of External Device set with GP-Pro EX. (Initial value [PLC1])
Error Message	Displays messages related to the error which occurs.
Error Occurrence Area	Displays IP address or device address of External Device where error occurs, or error codes received from External Device. <div style="border: 1px solid black; padding: 2px; display: inline-block;"><b>NOTE</b></div> <ul style="list-style-type: none"> <li>• IP address is displayed such as "IP address (Decimal): MAC address (Hex)".</li> <li>• Device address is displayed such as "Address: Device address".</li> <li>• Received error codes are displayed such as "Decimal [Hex]".</li> </ul>

Display Examples of Error Messages

"RHAA035:PLC1: Error has been responded for device write command (Error Code: 2 [02H])"

**NOTE**

- Refer to your External Device manual for details on received error codes.
- Refer to "When an error is displayed (Error Code List)" in "Maintenance/Troubleshooting Manual" for details on the error messages common to the driver.

### ■ Error Codes Unique to External Device

Error Code	Description
01H	ILLEGAL FUNCTION
02H	ILLEGAL DATA ADDRESS
03H	ILLEGAL DATA VALUE
04H	SLAVE DEVICE FAILURE

