



Temperature Controller MODBUS SIO Driver

1	System Configuration.....	3
2	External Device Selection	7
3	Communication Settings	8
4	Setup Items	24
5	Cable Diagrams	29
6	Supported Devices.....	58
7	Device Code and Address Code.....	63
8	Error Messages.....	64

Introduction

This manual describes how to connect the Display and the External Device (target Temp. Controller).

In this manual, the connection procedure is described in the sections identified below:

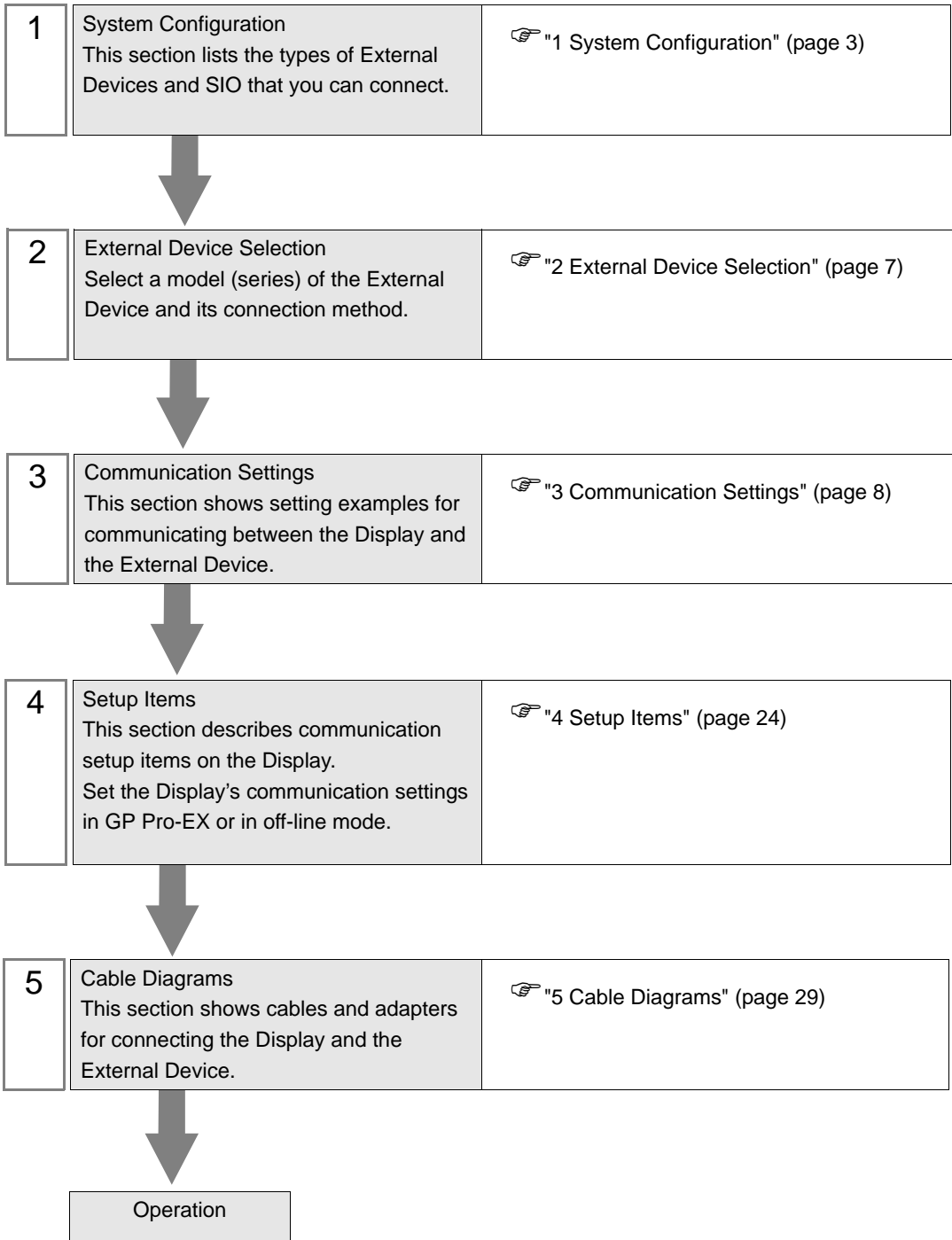

1 System Configuration

The following table lists system configurations for connecting Fuji Electric Systems Co.,Ltd. External Devices and the Display.

Series	CPU	Link I/F	SIO Type	Setting Example	Cable Diagram
PXH	PXH□□□□□□-□□■□□□*1	PC Loader Port on CPU Unit	RS-232C	"Setting Example 1" (page 8)	" Cable Diagram 1" (page 29)
		Port on CPU Unit	RS-422/485 (2 wire)	"Setting Example 2" (page 10)	" Cable Diagram 2" (page 31)
PXG	PXG4□□■□-□□□□□□-□*2 PXG5□□■□-□□□□□□-□*2 PXG9□□■□-□□□□□□-□*2	PC Loader Port on CPU Unit	RS-232C	"Setting Example 3" (page 12)	" Cable Diagram 1" (page 29)
		Port on CPU Unit	RS-422/485 (2 wire)	"Setting Example 4" (page 14)	" Cable Diagram 3" (page 40)
PXR (AutoFIX)	PXR3□□□□-□□■□□□-□*3 PXR4□□□□-□□■□□□*3*4*5 PXR5□□□□-□□■□□□*3 PXR7□□□□-□□■□□□*3 PXR9□□□□-□□■□□□*3	Port on CPU Unit	RS-422/485 (2 wire)	"Setting Example 5" (page 16)	" Cable Diagram 3" (page 40)
PXR (NoAuto-FIX)	PXR4□□□□-□□■□□□*3*4*6	Port on CPU Unit	RS-422/485 (2 wire)	"Setting Example 6" (page 18)	" Cable Diagram 3" (page 40)
PUM	PUMA□□□□-□□□□□□ PUMB□□□□-□□□□□□ PUME□□□□-□□ PUMV□□□□-□□□□□□ PUMN□□□□-□□□□□□ PUMT□□□□-□□□□□□	PC Loader Port on CPU Unit	RS-232C	"Setting Example 7" (page 20)	" Cable Diagram 1" (page 29)
		Port on CPU Unit	RS-422/485 (2 wire)	"Setting Example 8" (page 22)	" Cable Diagram 4" (page 49)

*1 The CPU type can be connected with RS-422/485 (2 wire) when the ■ section includes the following code:
R (RS-485)

*2 The CPU type can be connected with RS-422/485 (2 wire) when the ■ section includes the following codes:
M (RS-485)
V (RS-485 + Digital input (No.1))
K (RS-485 + RSV1)
J (RS-485 + CT1)
F (RS-485 + Digital input (No.1) + RSV1)
U (RS-485 + Digital input (No.1, 2, 3))

*3 The CPU type can be connected with RS-422/485 (2 wire) when the ■ section includes the following codes:
M (RS-485 Modbus interface)
V (RS-485 Modbus interface + Digital input 1 point)

*4 PXR4 Socket type cannot be connected because it lacks a serial port option.

*5 CPU Unit released in July 2001 or later

*6 CPU Unit released in June 2001 or earlier

■ Connection Configuration

- 1:1 Connection

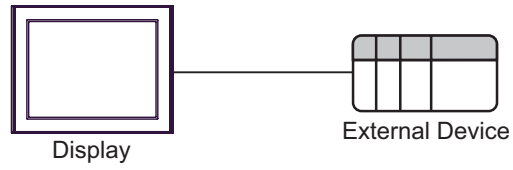

- 1:n Connection

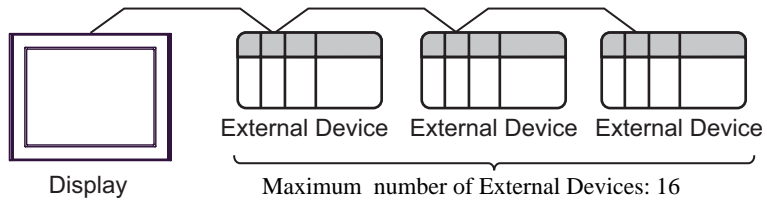

■ IPC COM Port

When connecting IPC with an External Device, the COM port used depends on the series and SIO type. Please refer to the IPC manual for details.

Usable port

Series	Usable Port		
	RS-232C	RS-422/485(4 wire)	RS-422/485(2 wire)
PS-2000B	COM1 ^{*1} , COM2, COM3 ^{*1} , COM4	-	-
PS-3450A, PS-3451A, PS3000-BA, PS3001-BD	COM1, COM2 ^{*1*2}	COM2 ^{*1*2}	COM2 ^{*1*2}
PS-3650A, PS-3651A	COM1 ^{*1}	-	-
PS-3700A (Pentium®4-M) PS-3710A	COM1 ^{*1} , COM2 ^{*1} , COM3 ^{*2} , COM4	COM3 ^{*2}	COM3 ^{*2}
PS-3711A	COM1 ^{*1} , COM2 ^{*2}	COM2 ^{*2}	COM2 ^{*2}
PL-3000B, PL-3600T, PL-3600K, PL-3700T, PL-3700K, PL-3900T	COM1 ^{*1*2} , COM2 ^{*1} , COM3, COM4	COM1 ^{*1*2}	COM1 ^{*1*2}

*1 The RI/5V can be switched. Use the IPC's switch to change if necessary.

*2 Set up the SIO type with the DIP switch. Please set up as follows according to SIO type to be used.

DIP switch setting: RS-232C

DIP switch	Setting	Description
1	OFF ^{*1}	Reserved (always OFF)
2	OFF	SIO type: RS-232C
3	OFF	
4	OFF	Output mode of SD (TXD) data: Always output
5	OFF	Terminal resistance (220Ω) insertion to SD (TXD): None
6	OFF	Terminal resistance (220Ω) insertion to RD (RXD): None
7	OFF	Short-circuit of SDA (TXA) and RDA (RXA): Not available
8	OFF	Short-circuit of SDB (TXB) and RDB (RXB): Not available
9	OFF	RS (RTS) Auto control mode: Disabled
10	OFF	

*1 When using PS-3450A, PS-3451A, PS3000-BA and PS3001-BD, turn ON the set value.

DIP switch setting: RS-422/485 (4 wire)

DIP switch	Setting	Description
1	OFF	Reserved (always OFF)
2	ON	SIO type: RS-422/485
3	ON	
4	OFF	Output mode of SD (TXD) data: Always output
5	OFF	Terminal resistance (220Ω) insertion to SD (TXD): None
6	OFF	Terminal resistance (220Ω) insertion to RD (RXD): None
7	OFF	Short-circuit of SDA (TXA) and RDA (RXA): Not available
8	OFF	Short-circuit of SDB (TXB) and RDB (RXB): Not available
9	OFF	RS (RTS) Auto control mode: Disabled
10	OFF	

DIP switch setting: RS-422/485 (2 wire)

DIP switch	Setting	Description
1	OFF	Reserved (always OFF)
2	ON	SIO type: RS-422/485
3	ON	
4	OFF	Output mode of SD (TXD) data: Always output
5	OFF	Terminal resistance (220Ω) insertion to SD (TXD): None
6	OFF	Terminal resistance (220Ω) insertion to RD (RXD): None
7	ON	Short-circuit of SDA (TXA) and RDA (RXA): Available
8	ON	Short-circuit of SDB (TXB) and RDB (RXB): Available
9	ON	RS (RTS) Auto control mode: Enabled
10	ON	

2 External Device Selection

Select the External Device to be connected to the Display.

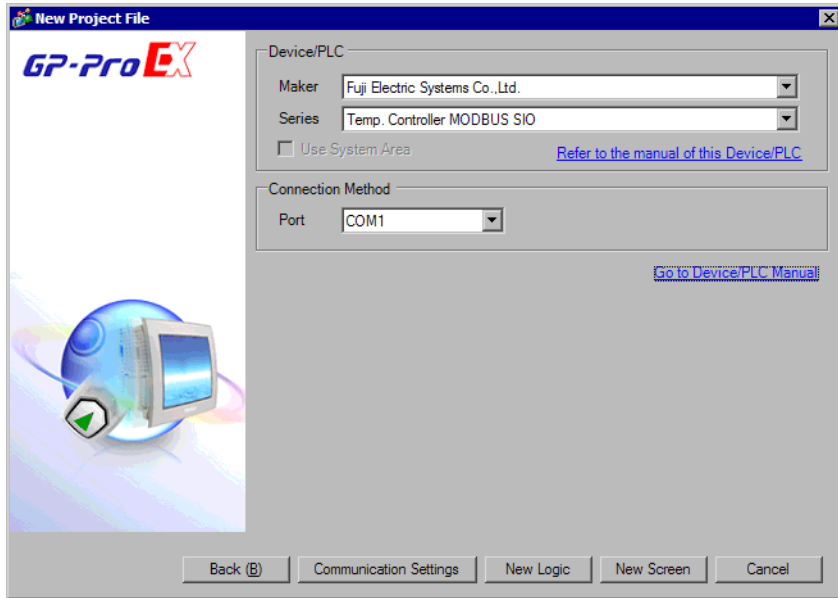

Setup Items	Setup Description
Maker	Select the maker of the External Device to be connected. Select "Fuji Electric Systems Co., Ltd.".
Series	Select a model (series) of the External Device to be connected and connection method. Select "Temp. Controller MODBUS SIO". In System configuration, check to make sure the external device to which you are connecting is supported in "Temp. Controller MODBUS SIO". ☞ "1 System Configuration" (page 3)
Use System Area	Not available for this driver.
Port	Select the Display port to be connected to the External Device.

3 Communication Settings

This section provides examples of communication settings recommended by Pro-face for the Display and the External Device.

3.1 Setting Example 1

■ GP Pro-EX Settings



◆ Communication Settings

To display the setup screen, from the [System Settings] workspace, select [Device/PLC].

The screenshot shows the 'Device/PLC 1' configuration window. It is divided into several sections:

- Summary:**
 - Maker: Fuji Electric Systems Co.,Ltd.
 - Series: Temp. Controller MODBUS SIO
 - Port: COM1
 - Text Data Mode: 1 (with a 'Change' link)
 - A 'Change Device/PLC' link is in the top right.
- Communication Settings:**
 - SIO Type: RS232C, RS422/485(2wire), RS422/485(4wire)
 - Speed: 38400 (dropdown)
 - Data Length: 7, 8
 - Parity: NONE, EVEN, ODD
 - Stop Bit: 1, 2
 - Flow Control: NONE, ER(DTR/CTS), XON/XOFF
 - Timeout: 3 (sec)
 - Retry: 2
 - Wait To Send: 10 (ms)
 - RI / VCC: RI, VCC. A note below states: 'In the case of RS232C, you can select the 9th pin to RI (Input) or VCC (5V Power Supply). If you use the Digital's RS232C Isolation Unit, please select it to VCC.'
 - A 'Default' button is located at the bottom right of this section.
- Device-Specific Settings:**
 - Allowable Number of Devices/PLCs: 16
 - Number: 1, Device Name: PLC1
 - Settings: Series=PXH Series, Station No.=1

◆ Device Setting

To display the [Individual Device Settings] dialog box, select the external device and click  [Settings] from [Device-Specific Settings] in the [Device/PLC] window. To connect multiple External Devices, click  from [Device-Specific Settings] in the [Device/PLC] window to add another External Device.

The screenshot shows the 'Individual Device Settings' dialog box for PLC1. It contains the following fields and controls:

- Series: PXH Series (dropdown menu)
- A note: 'If you change the series, please reconfirm all address settings.'
- Station No.: 1 (spin box)
- Buttons: Default, OK (O), and Cancel.

■ External Device Settings

For External Device communication settings, use the SEL key, UP key, DOWN key, Digit selection key, or DISP key located in the operation area on the front of the controller.

Refer to your External Device manual for details.

- 1 Press SEL key.
- 2 Press UP key or DOWN key to display [COM].
- 3 Press SEL key.
- 4 Press UP key or DOWN key to display the setting parameter.
- 5 Press SEL key to switch to setting mode.
- 6 Press UP key, DOWN key or Digit selection key to display the setting value.
- 7 Press SEL key.
- 8 Press DISP key twice.
- 9 Reboot the External Device.

◆ Setting Value

Setting Parameter	Setting Value	Setup Description
SPD2	384	RS-232C communication speed
BIT2	8o	RS-232C bit format

3.2 Setting Example 2

■ GP Pro-EX Settings

◆ Communication Settings



To display the setup screen, from the [System Settings] workspace, select [Device/PLC].

The screenshot shows the 'Device/PLC 1' configuration window. It is divided into several sections:

- Summary:** Includes fields for 'Maker' (Fuji Electric Systems Co.,Ltd.), 'Series' (Temp. Controller MODBUS SIO), and 'Port' (COM1). There is a 'Change Device/PLC' link.
- Text Data Mode:** Set to '1' with a 'Change' link.
- Communication Settings:**
 - SIO Type:** Radio buttons for RS232C, RS422/485(2wire) (selected), and RS422/485(4wire).
 - Speed:** A dropdown menu set to 38400.
 - Data Length:** Radio buttons for 7 and 8 (selected).
 - Parity:** Radio buttons for NONE, EVEN, and ODD (selected).
 - Stop Bit:** Radio buttons for 1 (selected) and 2.
 - Flow Control:** Radio buttons for NONE (selected), ER(DTR/CTS), and XON/XOFF.
 - Timeout:** A numeric field set to 3 (sec).
 - Retry:** A numeric field set to 2.
 - Wait To Send:** A numeric field set to 10 (ms).
- RI / VCC:** Radio buttons for RI (selected) and VCC. A note below states: "In the case of RS232C, you can select the 9th pin to RI (Input) or VCC (5V Power Supply). If you use the Digital's RS232C Isolation Unit, please select it to VCC." A 'Default' button is present.
- Device-Specific Settings:** Shows 'Allowable Number of Devices/PLCs' as 16. Below is a table:

Number	Device Name	Settings
1	PLC1	Series=PXH Series, Station No.=1

◆ Device Setting

To display the [Individual Device Settings] dialog box, select the external device and click  [Settings] from [Device-Specific Settings] in the [Device/PLC] window. To connect multiple External Devices, click  from [Device-Specific Settings] in the [Device/PLC] window to add another External Device.

The screenshot shows the 'Individual Device Settings' dialog box for 'PLC1'. It contains the following fields and controls:

- Series:** A dropdown menu set to 'PXH Series'.
- Message:** "If you change the series, please reconfirm all address settings."
- Station No.:** A numeric field set to 1.
- Buttons:** 'Default', 'OK (O)', and 'Cancel'.

■ External Device Settings

For External Device communication settings, use the SEL key, UP key, DOWN key, Digit selection key, or DISP key located in the operation area on the front of the controller.

Refer to your External Device manual for details.

- 1 Press SEL key.
- 2 Press UP key or DOWN key to display [COM].
- 3 Press SEL key.
- 4 Press UP key or DOWN key to display the setting parameter.
- 5 Press SEL key to switch to setting mode.
- 6 Press UP key, DOWN key or Digit selection key to display the setting value.
- 7 Press SEL key.
- 8 Press DISP key twice.
- 9 Reboot the External Device.

◆ Setting Value

Setting Parameter	Setting Value	Setup Description
STN4	1	RS-485 station No.
SPD4	384	RS-485 communication speed
BIT4	8o	RS-485 bit format

3.3 Setting Example 3

■ GP Pro-EX Settings

◆ Communication Settings



To display the setup screen, from the [System Settings] workspace, select [Device/PLC].

The screenshot shows the 'Device/PLC 1' configuration window. It is divided into several sections:

- Summary:** Includes fields for 'Maker' (Fuji Electric Systems Co.,Ltd.), 'Series' (Temp. Controller MODBUS SIO), and 'Port' (COM1). There is a 'Change Device/PLC' link.
- Text Data Mode:** Set to '1' with a 'Change' link.
- Communication Settings:**
 - SIO Type:** Radio buttons for RS232C (selected), RS422/485(2wire), and RS422/485(4wire).
 - Speed:** A dropdown menu set to '9600'.
 - Data Length:** Radio buttons for 7 and 8 (8 is selected).
 - Parity:** Radio buttons for NONE (selected), EVEN, and ODD.
 - Stop Bit:** Radio buttons for 1 (selected) and 2.
 - Flow Control:** Radio buttons for NONE (selected), ER(DTR/CTS), and XON/XOFF.
 - Timeout:** A spin box set to '3' (sec).
 - Retry:** A spin box set to '2'.
 - Wait To Send:** A spin box set to '10' (ms).
- RI / VCC:** Radio buttons for RI (selected) and VCC. A note below states: "In the case of RS232C, you can select the 9th pin to RI (Input) or VCC (5V Power Supply). If you use the Digital's RS232C Isolation Unit, please select it to VCC." A 'Default' button is present.
- Device-Specific Settings:** Shows 'Allowable Number of Devices/PLCs' as 16. Below is a table:

Number	Device Name	Settings
1	PLC1	Series=PXG Series, Station No.=1

◆ Device Setting

To display the [Individual Device Settings] dialog box, select the external device and click  [Settings] from [Device-Specific Settings] in the [Device/PLC] window. To connect multiple External Devices, click  from [Device-Specific Settings] in the [Device/PLC] window to add another External Device.

The screenshot shows the 'Individual Device Settings' dialog box for 'PLC1'. It contains the following fields and controls:

- Series:** A dropdown menu set to 'PXG Series'.
- Message:** "If you change the series, please reconfirm all address settings."
- Station No.:** A spin box set to '1'.
- Buttons:** 'Default', 'OK (O)', and 'Cancel'.

■ External Device Settings

External Device communication settings are fixed as indicated below.

Setting Items	Setting Value
Communication speed	9600
Data length	8
Stop bit	1
Parity	None

3.4 Setting Example 4

■ GP Pro-EX Settings

◆ Communication Settings



To display the setup screen, from the [System Settings] workspace, select [Device/PLC].

The screenshot shows the 'Device/PLC 1' configuration window. It is divided into several sections:

- Summary:** Includes fields for 'Maker' (Fuji Electric Systems Co.,Ltd.), 'Series' (Temp. Controller MODBUS SIO), and 'Port' (COM1). There is a 'Change Device/PLC' link.
- Text Data Mode:** Set to '1' with a 'Change' link.
- Communication Settings:**
 - SIO Type:** Radio buttons for RS232C, RS422/485(2wire) (selected), and RS422/485(4wire).
 - Speed:** A dropdown menu set to '9600'.
 - Data Length:** Radio buttons for 7 and 8 (selected).
 - Parity:** Radio buttons for NONE, EVEN, and ODD (selected).
 - Stop Bit:** Radio buttons for 1 (selected) and 2.
 - Flow Control:** Radio buttons for NONE (selected), ER(DTR/CTS), and XON/XOFF.
 - Timeout:** A numeric field set to '3' with '(sec)' next to it.
 - Retry:** A numeric field set to '2'.
 - Wait To Send:** A numeric field set to '10' with '(ms)' next to it.
- RI / VCC:** Radio buttons for RI (selected) and VCC. A note below states: 'In the case of RS232C, you can select the 9th pin to RI (Input) or VCC (5V Power Supply). If you use the Digital's RS232C Isolation Unit, please select it to VCC.' A 'Default' button is present.
- Device-Specific Settings:** Shows 'Allowable Number of Devices/PLCs' as 16. Below is a table:

Number	Device Name	Settings
1	PLC1	Series=FXG Series,Station No.=1

◆ Device Setting

To display the [Individual Device Settings] dialog box, select the external device and click  [Settings] from [Device-Specific Settings] in the [Device/PLC] window. To connect multiple External Devices, click  from [Device-Specific Settings] in the [Device/PLC] window to add another External Device.

The screenshot shows the 'Individual Device Settings' dialog box for 'PLC1'. It contains the following fields and controls:

- Series:** A dropdown menu set to 'PXG Series'.
- Message:** 'If you change the series, please reconfirm all address settings.'
- Station No.:** A numeric field set to '1'.
- Buttons:** 'Default', 'OK (O)', and 'Cancel'.

■ External Device Settings

For External Device communication settings, use the SEL key, UP key, DOWN key, or USER key, located in the operation area on the front of the controller.

Refer to your External Device manual for details.

- 1 Press and hold SEL key to switch to Monitor Mode.
- 2 Press and hold SEL key to switch to Setup Mode.
- 3 Press UP key or DOWN key to display [CoM Ch 9].
- 4 Press and hold SEL key.
- 5 Press UP key or DOWN key to display setting parameter.
- 6 Press SEL key.
- 7 Press UP key or DOWN key to display setting value.
- 8 Press SEL key.
- 9 Press USER key.
- 10 Reboot the External Device.

◆ Setting Value

Setting Parameter	Setting Value	Setup Description
STno	1	ST No. setting
CoM	960d	RS-485 Baud rate/Parity settings
SCC	rW	RS-485 Communication permissions

3.5 Setting Example 5

■ GP Pro-EX Settings

◆ Communication Settings



To display the setup screen, from the [System Settings] workspace, select [Device/PLC].

The screenshot shows the 'Device/PLC 1' configuration window. It is divided into several sections:

- Summary:** Includes fields for 'Maker' (Fuji Electric Systems Co.,Ltd.), 'Series' (Temp. Controller MODBUS SIO), and 'Port' (COM1). There is a 'Change Device/PLC' link.
- Text Data Mode:** Set to '1' with a 'Change' button.
- Communication Settings:**
 - SIO Type:** Radio buttons for RS232C, RS422/485(2wire) (selected), and RS422/485(4wire).
 - Speed:** A dropdown menu set to '9600'.
 - Data Length:** Radio buttons for 7 and 8 (selected).
 - Parity:** Radio buttons for NONE, EVEN, and ODD (selected).
 - Stop Bit:** Radio buttons for 1 (selected) and 2.
 - Flow Control:** Radio buttons for NONE (selected), ER(DTR/CTS), and XON/XOFF.
 - Timeout:** A spinner box set to '3' (sec).
 - Retry:** A spinner box set to '2'.
 - Wait To Send:** A spinner box set to '10' (ms).
- RI / VCC:** Radio buttons for RI (selected) and VCC. A note below states: "In the case of RS232C, you can select the 9th pin to RI (Input) or VCC (5V Power Supply). If you use the Digital's RS232C Isolation Unit, please select it to VCC." A 'Default' button is also present.
- Device-Specific Settings:** Shows 'Allowable Number of Devices/PLCs' as 16. Below is a table:

Number	Device Name	Settings
1	PLC1	Series=PXR Series(AutoFIX), Station No.=1

◆ Device Setting

To display the [Individual Device Settings] dialog box, select the external device and click  [Settings] from [Device-Specific Settings] in the [Device/PLC] window. To connect multiple External Devices, click  from [Device-Specific Settings] in the [Device/PLC] window to add another External Device.

The screenshot shows the 'Individual Device Settings' dialog box for 'PLC1'. It contains the following fields and controls:

- Series:** A dropdown menu set to 'PXR Series(AutoFIX)'.
- Message:** "If you change the series, please reconfirm all address settings."
- Station No.:** A spinner box set to '1'.
- Buttons:** 'Default', 'OK (O)', and 'Cancel'.

■ External Device Settings

For External Device communication settings, use the SEL key, UP key, or DOWN key located in the operation area on the front of the controller.

Refer to your External Device manual for details.

- 1 Press and hold SEL key to display the 3rd block parameter.
- 2 Press UP key or DOWN key to display setting parameter.
- 3 Press SEL key.
- 4 Press UP key or DOWN key to display setting value.
- 5 Press SEL key.
- 6 Press and hold SEL key.

◆ Setting Value

Setting Parameter	Setting Value	Setup Description
STno	1	Station No.
CoM	0	Parity setting
PCoL	1	Communication protocol

3.6 Setting Example 6

■ GP Pro-EX Settings

◆ Communication Settings



To display the setup screen, from the [System Settings] workspace, select [Device/PLC].

The screenshot shows the 'Device/PLC 1' configuration window. It is divided into several sections:

- Summary:** Includes fields for 'Maker' (Fuji Electric Systems Co.,Ltd.), 'Series' (Temp. Controller MODBUS SIO), and 'Port' (COM1). There is a 'Change Device/PLC' link.
- Text Data Mode:** Set to '1' with a 'Change' link.
- Communication Settings:**
 - SIO Type:** Radio buttons for RS232C, RS422/485(2wire) (selected), and RS422/485(4wire).
 - Speed:** A dropdown menu set to '9600'.
 - Data Length:** Radio buttons for 7 and 8 (selected).
 - Parity:** Radio buttons for NONE, EVEN, and ODD (selected).
 - Stop Bit:** Radio buttons for 1 (selected) and 2.
 - Flow Control:** Radio buttons for NONE (selected), ER(DTR/CTS), and XON/XOFF.
 - Timeout:** A spinner box set to '3' (sec).
 - Retry:** A spinner box set to '2'.
 - Wait To Send:** A spinner box set to '10' (ms).
- RI / VCC:** Radio buttons for RI (selected) and VCC. A note below states: 'In the case of RS232C, you can select the 9th pin to RI (Input) or VCC (5V Power Supply). If you use the Digital's RS232C Isolation Unit, please select it to VCC.' A 'Default' button is present.
- Device-Specific Settings:** Shows 'Allowable Number of Devices/PLCs' as 16. A table lists the device:

Number	Device Name	Settings
1	PLC1	Series=PxR Series(NoAutoFix),Station No.=1

◆ Device Setting

To display the [Individual Device Settings] dialog box, select the external device and click  [Settings] from [Device-Specific Settings] in the [Device/PLC] window. To connect multiple External Devices, click  from [Device-Specific Settings] in the [Device/PLC] window to add another External Device.

The screenshot shows the 'Individual Device Settings' dialog box for 'PLC1'. It contains the following fields and controls:

- Series:** A dropdown menu set to 'PxR Series(NoAutoFix)'.
- Message:** 'If you change the series, please reconfirm all address settings.'
- Station No.:** A spinner box set to '1'.
- Buttons:** 'Default', 'OK (O)', and 'Cancel'.

■ External Device Settings

For External Device communication settings, use the SEL key, UP key, or DOWN key located in the operation area on the front of the controller.

Refer to your External Device manual for details.

- 1 Press and hold SEL key to display the 3rd block parameter.
- 2 Press UP key or DOWN key to display setting parameter.
- 3 Press SEL key.
- 4 Press UP key or DOWN key to display setting value.
- 5 Press SEL key.
- 6 Press and hold SEL key.

◆ Setting Value

Setting Parameter	Setting Value	Setup Description
STno	1	Station No.
CoM	0	Parity setting
PCoL	1	Communication protocol

3.7 Setting Example 7

■ GP Pro-EX Settings

◆ Communication Settings



To display the setup screen, from the [System Settings] workspace, select [Device/PLC].

The screenshot shows the 'Device/PLC 1' configuration window. It is divided into several sections:

- Summary:** Includes fields for 'Maker' (Fuji Electric Systems Co.,Ltd.), 'Series' (Temp. Controller MODBUS SIO), and 'Port' (COM1). There is a 'Change Device/PLC' link.
- Text Data Mode:** Set to '1' with a 'Change' link.
- Communication Settings:**
 - SIO Type:** Radio buttons for RS232C (selected), RS422/485(2wire), and RS422/485(4wire).
 - Speed:** A dropdown menu set to '19200'.
 - Data Length:** Radio buttons for 7 and 8 (selected).
 - Parity:** Radio buttons for NONE (selected), EVEN, and ODD.
 - Stop Bit:** Radio buttons for 1 (selected) and 2.
 - Flow Control:** Radio buttons for NONE (selected), ER(DTR/CTS), and XON/XOFF.
 - Timeout:** A numeric field set to '3' with '(sec)' next to it.
 - Retry:** A numeric field set to '2'.
 - Wait To Send:** A numeric field set to '10' with '(ms)' next to it.
- RI / VCC:** Radio buttons for RI (selected) and VCC. A note below states: 'In the case of RS232C, you can select the 9th pin to RI (Input or VCC (5V Power Supply)). If you use the Digital's RS232C Isolation Unit, please select it to VCC.' A 'Default' button is present.
- Device-Specific Settings:** Shows 'Allowable Number of Devices/PLCs' as 16. Below is a table:

Number	Device Name	Settings
1	PLC1	Series=PUM Series, Station No.=1

◆ Device Setting

To display the [Individual Device Settings] dialog box, select the external device and click  [Settings] from [Device-Specific Settings] in the [Device/PLC] window. To connect multiple External Devices, click  from [Device-Specific Settings] in the [Device/PLC] window to add another External Device.

The screenshot shows the 'Individual Device Settings' dialog box for 'PLC1'. It contains the following fields and controls:

- Series:** A dropdown menu set to 'PUM Series'.
- Message:** 'If you change the series, please reconfirm all address settings.'
- Station No.:** A numeric field set to '1'.
- Buttons:** 'Default', 'OK (O)', and 'Cancel'.

■ External Device Settings

For External Device communication settings, use the Station No. Configuration switch on the front of the controller.

Refer to your External Device manual for details.

- 1 Set "0" to Station No. Configuration switch.

NOTE

- The Station Number is generated by adding 1 (one) to the value set by the Station No. Configuration switch.
-

Other communication settings are fixed as below.

Setting Items	Setting Value
Communication speed	19200
Data length	8
Stop bit	1
Parity	None

3.8 Setting Example 8

■ GP Pro-EX Settings

◆ Communication Settings

To display the setup screen, from the [System Settings] workspace, select [Device/PLC].

The screenshot shows the 'Device/PLC 1' configuration window. It is divided into several sections:

- Summary:** Includes fields for 'Maker' (Fuji Electric Systems Co.,Ltd.), 'Series' (Temp. Controller MODBUS SIO), and 'Port' (COM1). There is a 'Change Device/PLC' link.
- Text Data Mode:** Set to '1' with a 'Change' link.
- Communication Settings:**
 - SIO Type:** Radio buttons for RS232C, RS422/485(2wire) (selected), and RS422/485(4wire).
 - Speed:** A dropdown menu set to '19200'.
 - Data Length:** Radio buttons for 7 and 8 (selected).
 - Parity:** Radio buttons for NONE (selected), EVEN, and ODD.
 - Stop Bit:** Radio buttons for 1 (selected) and 2.
 - Flow Control:** Radio buttons for NONE (selected), ER(DTR/CTS), and XON/XOFF.
 - Timeout:** A spinner box set to '3' (sec).
 - Retry:** A spinner box set to '2'.
 - Wait To Send:** A spinner box set to '10' (ms).
- RI / VCC:** Radio buttons for RI (selected) and VCC. A note below states: "In the case of RS232C, you can select the 9th pin to RI (Input) or VCC (5V Power Supply). If you use the Digital's RS232C Isolation Unit, please select it to VCC." A 'Default' button is present.
- Device-Specific Settings:**
 - 'Allowable Number of Devices/PLCs' is set to '16'.
 - A table lists devices:

Number	Device Name	Settings
1	PLC1	Series=PUM Series, Station No.=1

◆ Device Setting

To display the [Individual Device Settings] dialog box, select the external device and click [Settings] from [Device-Specific Settings] in the [Device/PLC] window. To connect multiple External Devices, click from [Device-Specific Settings] in the [Device/PLC] window to add another External Device.

The screenshot shows the 'Individual Device Settings' dialog box for 'PLC1'. It contains the following fields and controls:

- Series:** A dropdown menu set to 'PUM Series'.
- A note: "If you change the series, please reconfirm all address settings."
- Station No.:** A spinner box set to '1'.
- Buttons: 'Default', 'OK (O)', and 'Cancel'.

■ External Device Settings

For External Device communication settings, use the Station No. Configuration switch on the front of the controller and Parameter Loader software (PUM Loader).

Refer to your External Device manual for details.

- 1 Set "0" to Station No. Configuration switch.

NOTE

- The Station Number is generated by adding 1 (one) to the value set by the Station No. Configuration switch.

- 2 Start up the Parameter Loader software.
- 3 Select [Control/Event/Analog Module] in the [Module type selection] dialog box.
- 4 Click [OK].
- 5 Select the any mode in the [Startup mode] dialog box.
- 6 Click [OK].
- 7 Select [Control module]-[Parameter]-[Communication] in the tree view of the main window.
- 8 Click the setting item to display the selection dialog box of the setting value.
- 9 Select the setting value.
- 10 Click [OK].
- 11 Transfer the communication settings to External Device.

◆ Setting Value

Setting Items	Setting Value
RS-485 Parity setting	None
RS-485 Communication speed	19.2Kbps
RS-485 Communication permission	1
RS-485 Response interval time	1
Enhanced comm. module (PUMC) connection	0

4 Setup Items

Set up the Display's communication settings in GP Pro-EX or in the Display's off-line mode.

The setting of each parameter must match that of the External Device.

 "3 Communication Settings" (page 8)

4.1 Setup Items in GP Pro-EX

■ Communication Settings

To display the setup screen, from the [System Settings] workspace, select [Device/PLC].

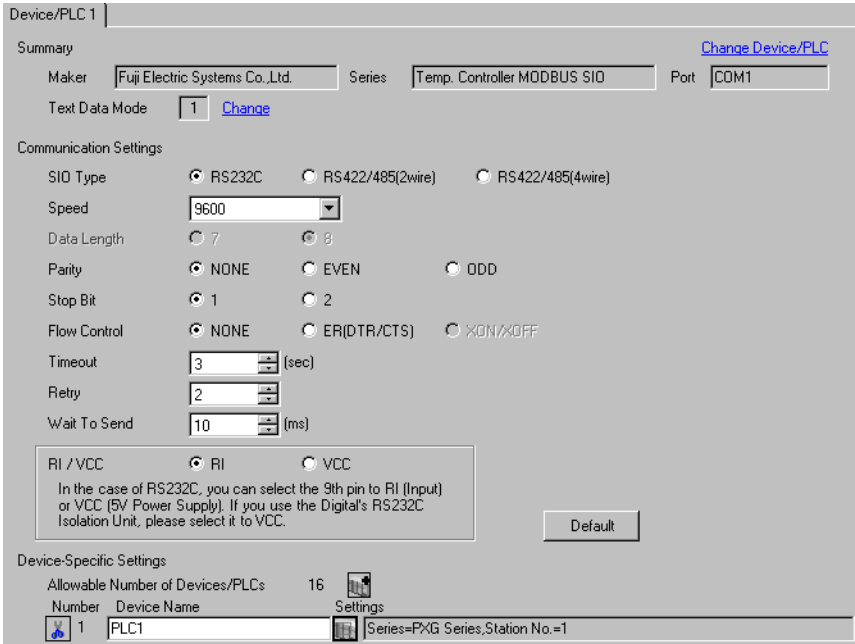



Setup Items	Setup Description
SIO Type	<p>Select the SIO type to communicate with the External Device.</p> <p>IMPORTANT</p> <p>TIn the communication setting, confirm the serial interface specifications of the Display and set [SIO Type] correctly.</p> <p>If you select an SIO type the serial interface does not support, we cannot guarantee the operation.</p> <p>Please refer to the manual of the Display for more detail on the serial interface specifications.</p>
Speed	Select communication speed between the External Device and the Display.
Data Length	Display data length.
Parity	Select how to check parity.
Stop Bit	Select stop bit length.

Continued

Setup Items	Setup Description
Flow Control	Select the communication control method to prevent overflow of transmission and reception data.
Timeout	Use an integer from 1 to 127 to enter the time (s) for which the Display waits for the response from the External Device.
Retry	In case of no response from the External Device, use an integer from 0 to 255 to enter how many times the Display retransmits the command.
Wait To Send	Use an integer from 0 to 255 to enter standby time (ms) for the Display from receiving packets to transmitting next commands.
RI/VCC	You can switch RI/VCC of the 9th pin when you select RS232C for SIO type. It is necessary to change RI/5V by changeover switch of IPC when connect with IPC. Please refer to the manual of the IPC for more detail.

■ Device Setting

To display the [Individual Device Settings] dialog box, select the external device and click  [Settings] from [Device-Specific Settings] in the [Device/PLC] window. To connect multiple External Devices, click  from [Device-Specific Settings] in the [Device/PLC] window to add another External Device.

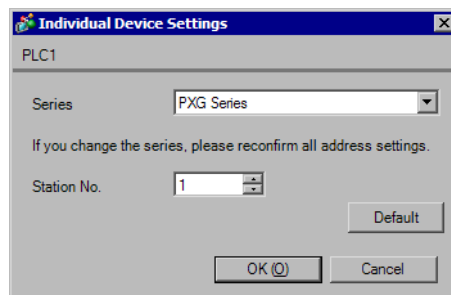

Setup Items	Setup Description
Series	Select the series of the External Device.
Station No.	Use an integer from 1 to 255 to enter the Station number of the External Device.

4.2 Setup Items in Off-line Mode

NOTE

- Refer to the Maintenance/Troubleshooting manual for information on how to enter off-line mode or about the operation.
Cf. Maintenance/Troubleshooting Manual "Off-line Mode"
- The number of the setup items to be displayed for 1 page in the off-line mode depends on the Display in use. Please refer to the Reference manual for details.

■ Communication Settings

To display the setting screen, touch [Device/PLC Settings] from [Peripheral Equipment Settings] in off-line mode. Touch the External Device you want to set from the displayed list.

Comm.	Device	Option		
Temp. Controller MODBUS SIO		[COM1]	Page 1/1	
SIO Type	RS422/485(2wire) ▼			
Speed	9600 ▼			
Data Length	8			
Parity	<input type="radio"/> NONE <input type="radio"/> EVEN <input checked="" type="radio"/> ODD			
Stop Bit	<input checked="" type="radio"/> 1 <input type="radio"/> 2			
Flow Control	NONE ▼			
Timeout(s)	3 ▼ ▲			
Retry	2 ▼ ▲			
Wait To Send(ms)	10 ▼ ▲			
Exit		Back		2008/12/22 15:12:18

Setup Items	Setup Description
SIO Type	Select the SIO type to communicate with the External Device. IMPORTANT In the communication setting, confirm the serial interface specifications of the Display and set [SIO Type] correctly. If you select an SIO type the serial interface does not support, we cannot guarantee the operation. Please refer to the manual of the Display for more detail on the serial interface specifications.
Speed	Select the communication speed between the External Device and the Display.
Data Length	Display data length.
Parity	Select how to check parity.
Stop Bit	Select stop bit length.

Continued

Setup Items	Setup Description
Flow Control	Select the communication control method to prevent overflow of transmission and reception data.
Timeout	Use an integer from 1 to 127 to enter the time (s) for which the Display waits for the response from the External Device.
Retry	In case of no response from the External Device, use an integer from "0 to 255" to enter how many times the Display retransmits the command.
Wait To Send	Use an integer from "0 to 255" to enter standby time (ms) for the Display from receiving packets to transmitting next commands.

■ Device Setting

To display the setting screen, touch [Device/PLC Settings] from [Peripheral Equipment Settings]. Touch the External Device you want to set from the displayed list, and touch [Device].

Comm.	Device	Option		
Temp. Controller MODBUS SIO		[COM1]	Page 1/1	
Device/PLC Name		[PLC1]		
Series		PXR Series(AutoFIX)		
Station No.		1		
Exit		Back		2008/12/22 15:12:22

Setup Items	Setup Description
Device/PLC Name	Select the External Device to set. Device name is a title of the External Device set with GP-Pro EX. (Initial value [PLC1])
Series	Display the series of the External Device.
Station No.	Use an integer from 1 to 255 to enter the Station number of the External Device.

■ Option

To display the setting screen, touch [Device/PLC Settings] from [Peripheral Equipment Settings]. Touch the External Device you want to set from the displayed list, and touch [Option].

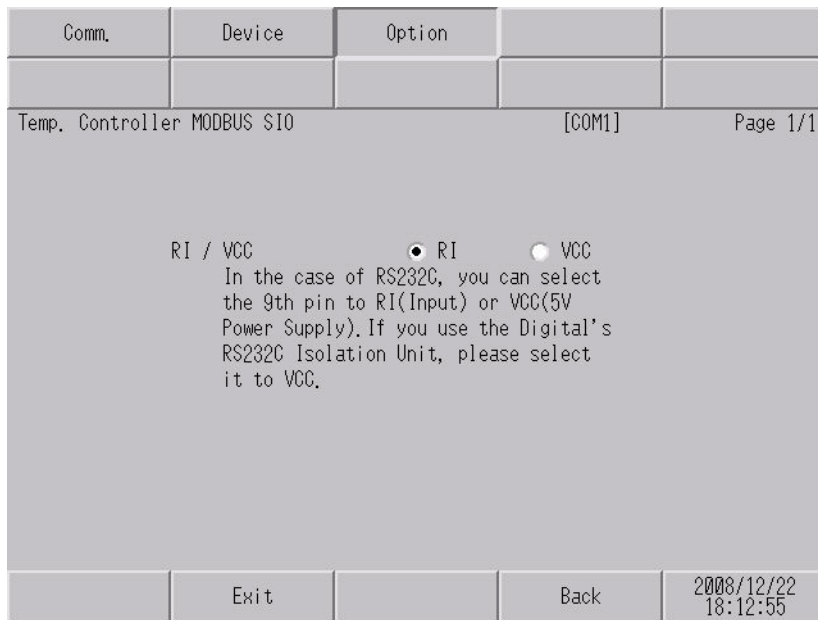

Setup Items	Setup Description
RI/VCC	You can switch RI/VCC of the 9th pin when you select RS232C for SIO type. It is necessary to change RI/5V by changeover switch of IPC when connect with IPC. Please refer to the manual of the IPC for more detail.

NOTE

- GP-4100 series do not have the [Option] setting in the off-line mode.

5 Cable Diagrams

The following cable diagrams may be different from cable diagrams recommended by Fuji Electric Systems Co., Ltd. Please be assured there is no operational problem in applying the cable diagrams shown in this manual.

- The FG pin of the External Device body must be D-class grounded. Refer to your External Device manual for more details.
- The SG and FG are connected inside the Display. When connecting the External Device to the SG, design your system to avoid short-circuit loops.
- Connect an isolation unit if the communication is not stable due to noise or other factors.

Cable Diagram 1

Display (Connection Port)	Cable		Notes
GP3000 (COM1) ST (COM1) LT (COM1) IPC* ¹ PC/AT	1A	Loader connecting cable by Fuji Electric Systems Co., Ltd.* ²	
GP-4105 (COM1)	1B	User-created cable + Loader connecting cable by Fuji Electric Systems Co., Ltd.* ²	

*1 Only the COM port which can communicate by RS-232C can be used.
 "■ IPC COM Port" (page 5)

*2 The loader connecting cable differs, depending on the series.

Series	Loader connecting cable type
PXH	ZZPPXH1*TK4H4563
PUM	PUMZ*L01

1A)

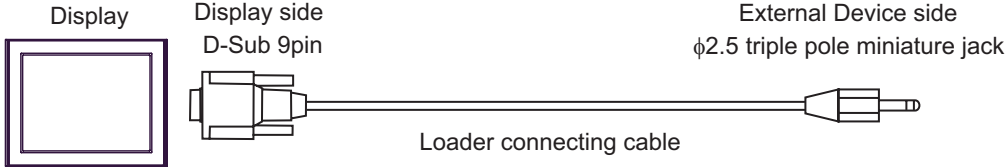

NOTE • Connect the loader connecting cable to the PC loader port of the External Device.

1B)

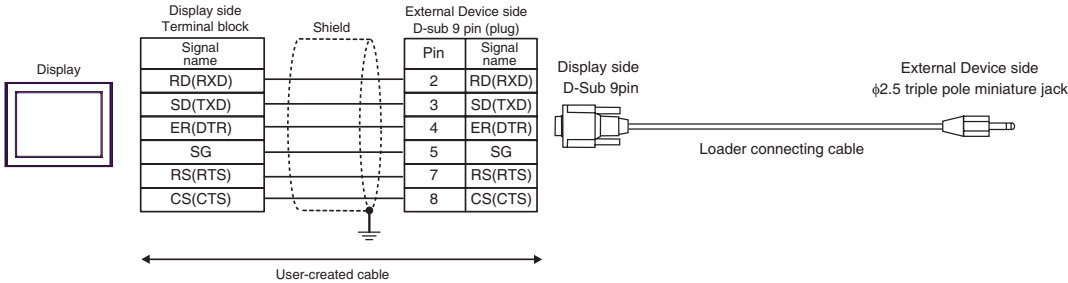

NOTE • Connect the loader connecting cable to the PC loader port of the External Device.

Cable Diagram 2

Display (Connection Port)	Cable		Notes
GP3000* ¹ (COM1) AGP-3302B (COM2) ST* ² (COM2) LT (COM1)	2A	COM port conversion adapter by Pro-face CA3-ADPCOM-01 + Terminal block conversion adapter by Pro-face CA3-ADPTRM-01 + User-created cable	Cable length: 500m or less
	2B	User-created cable	
GP3000* ³ (COM2)	2C	Online adapter by Pro-face CA4-ADPONL-01 + Terminal block conversion adapter by Pro-face CA3-ADPTRM-01 + User-created cable	
	2D	Online adapter by Pro-face CA4-ADPONL-01 + User-created cable	
IPC* ⁴	2E	COM port conversion adapter by Pro-face CA3-ADPCOM-01 + Terminal block conversion adapter by Pro-face CA3-ADPTRM-01 + User-created cable	
	2F	User-created cable	
GP-4106 (COM1)	2G	User-created cable	
GP-4107 (COM1)	2H	User-created cable	

*1 All GP3000 models except AGP-3302B

*2 All ST models except AST-3211A and AST-3302B

*3 All GP3000 models except GP-3200 series and AGP-3302B

*4 Only the COM port which can communicate by RS-422/485 (2 wire) can be used.
 "■ IPC COM Port" (page 5)

IMPORTANT

- Implement Type D installation to the shield connected to the FG.

2A)

- 1:1 Connection

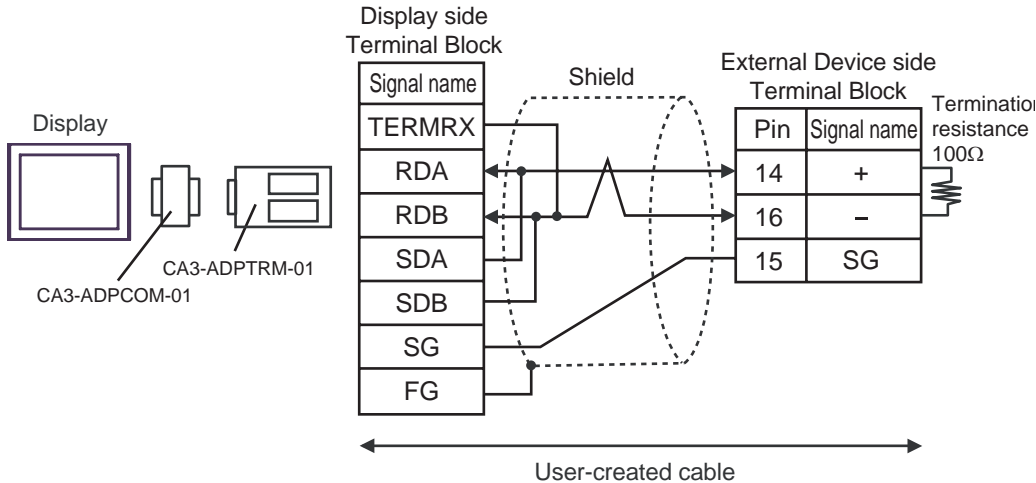

- 1:n Connection

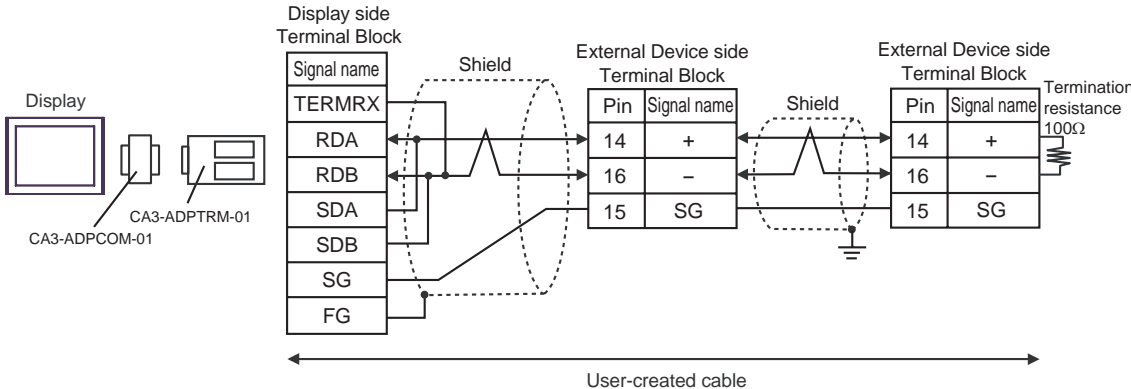

2B)

- 1:1 Connection

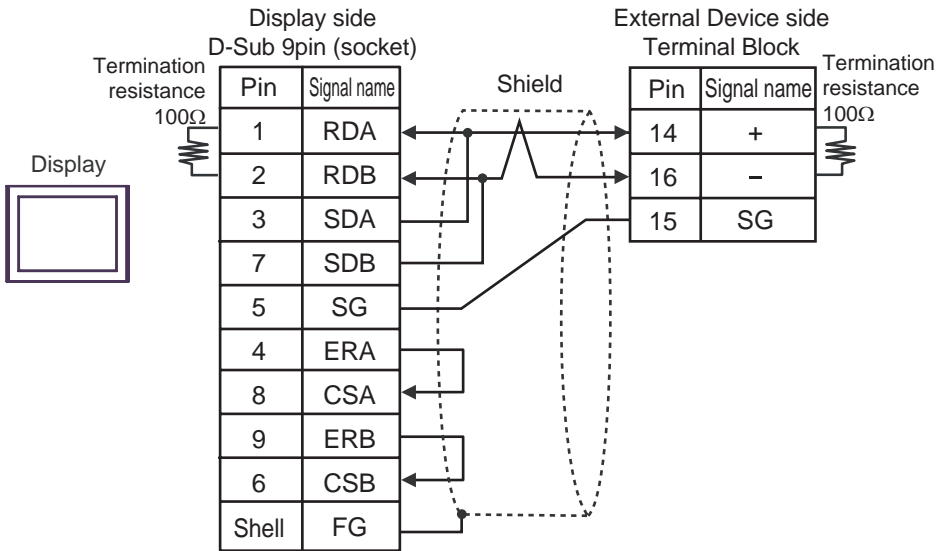

- 1:n Connection

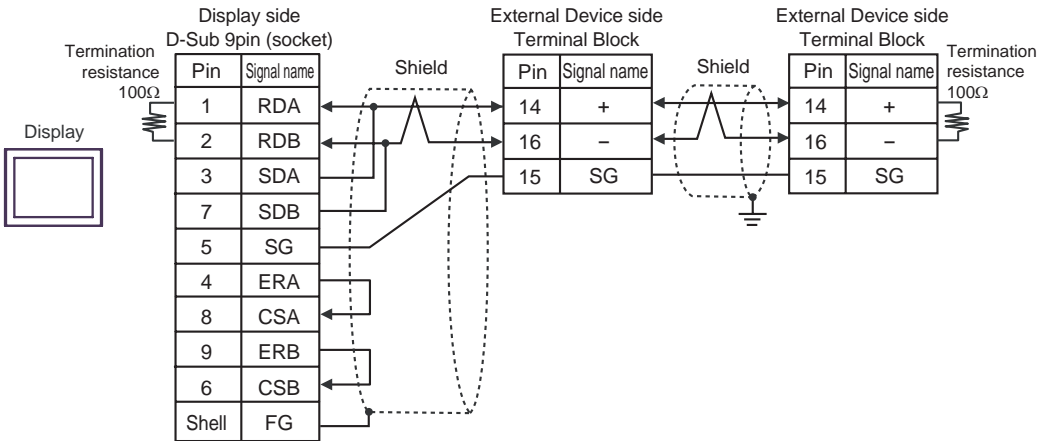

2C)

- 1:1 Connection

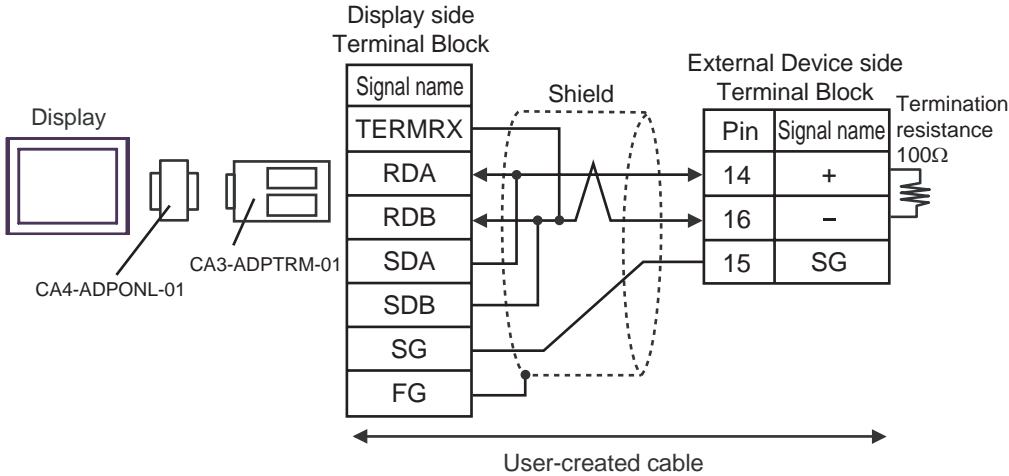

- 1:n Connection

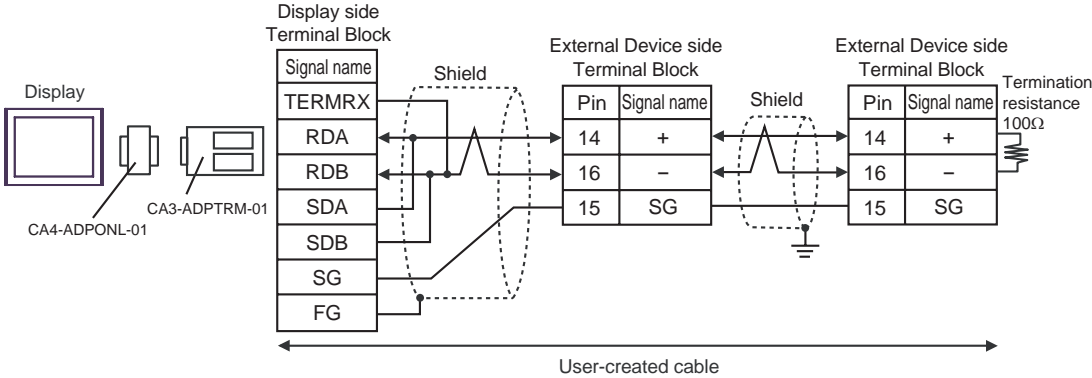

2D)

- 1:1 Connection

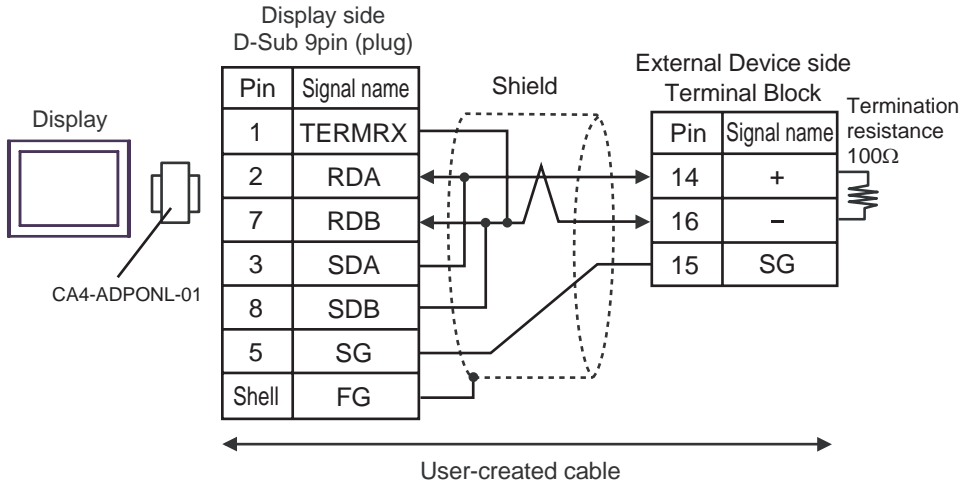

- 1:n Connection

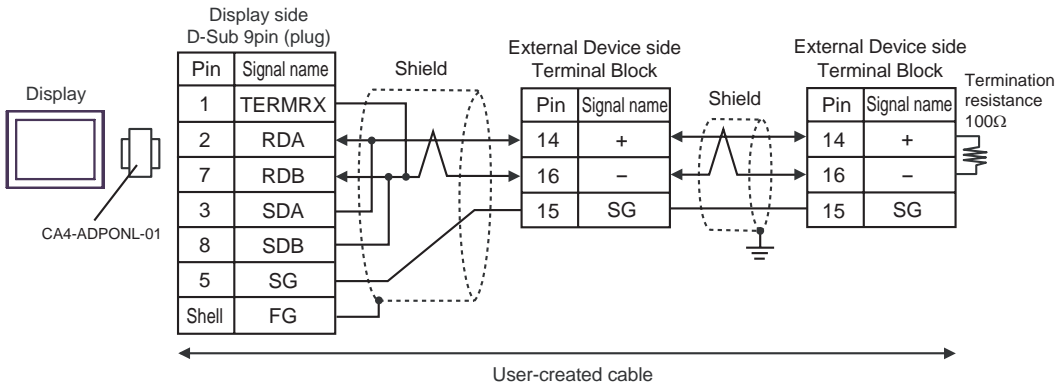

2E)

- 1:1 Connection

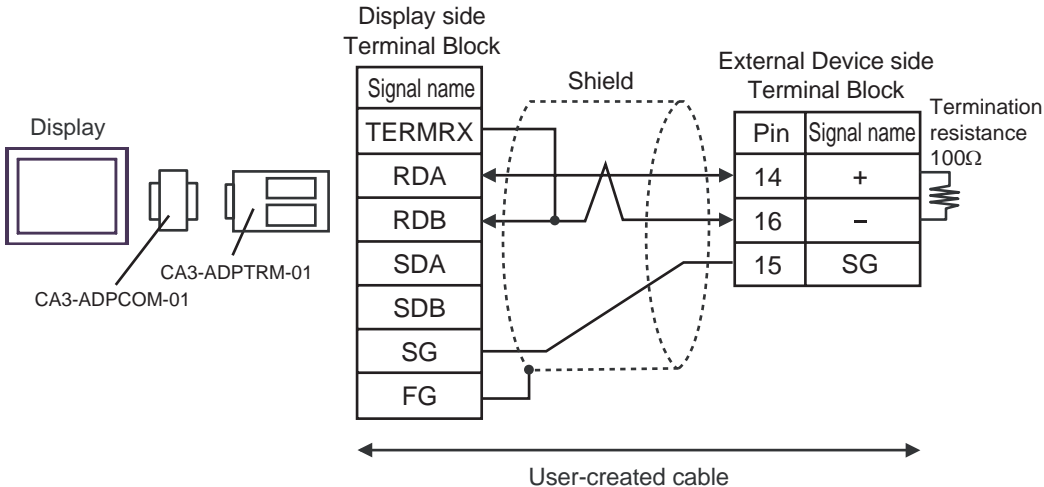

- 1:n Connection

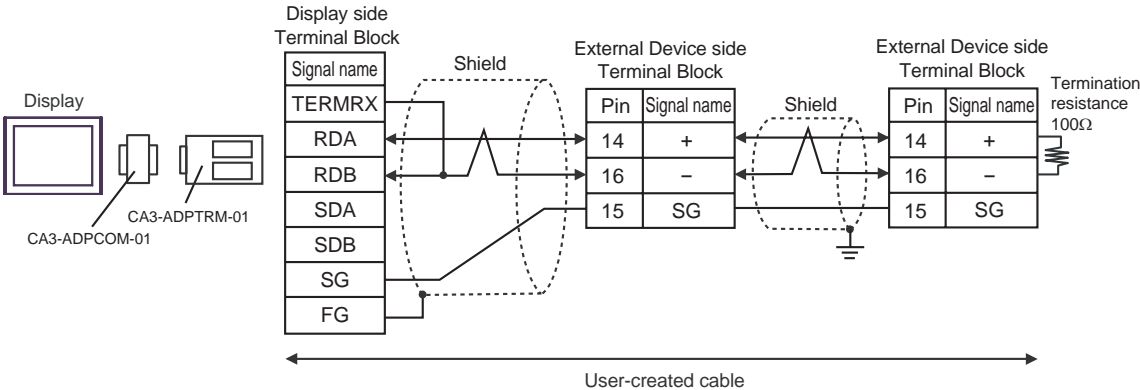

2F)

- 1:1 Connection

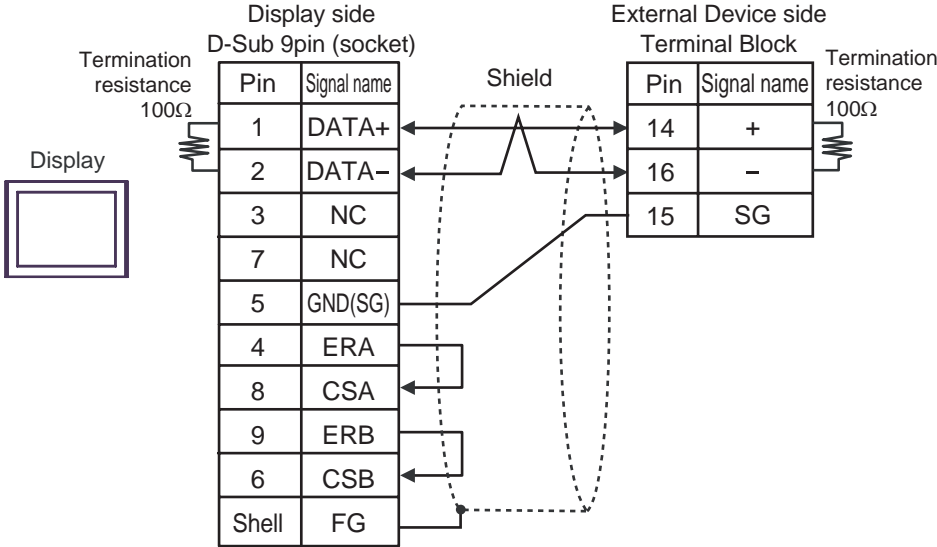

- 1:n Connection

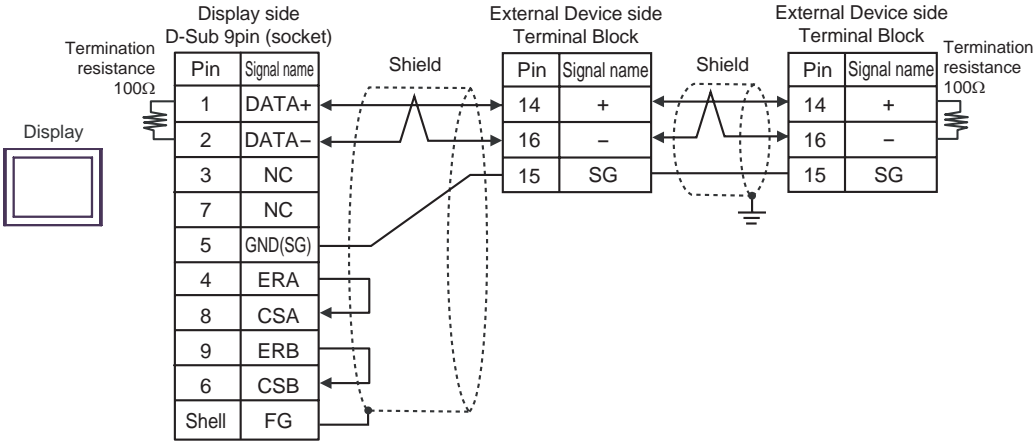

2G)

- 1:1 Connection

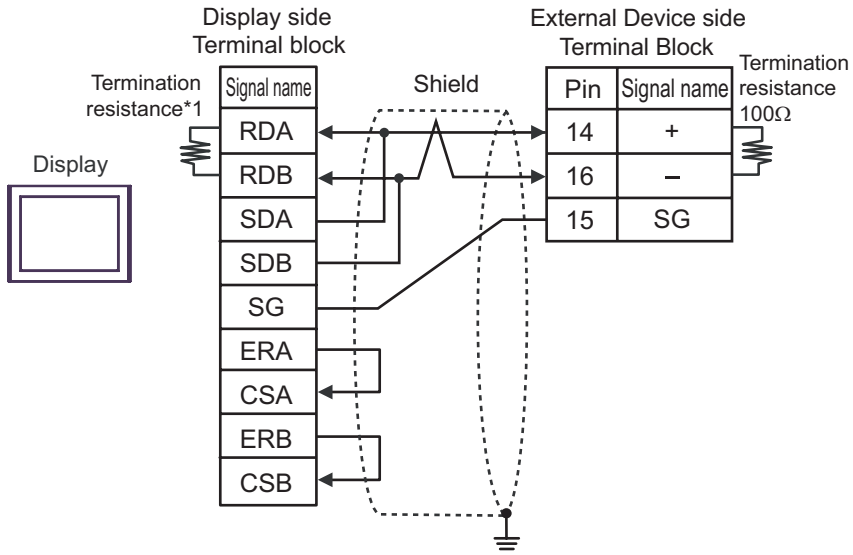

- 1:n Connection

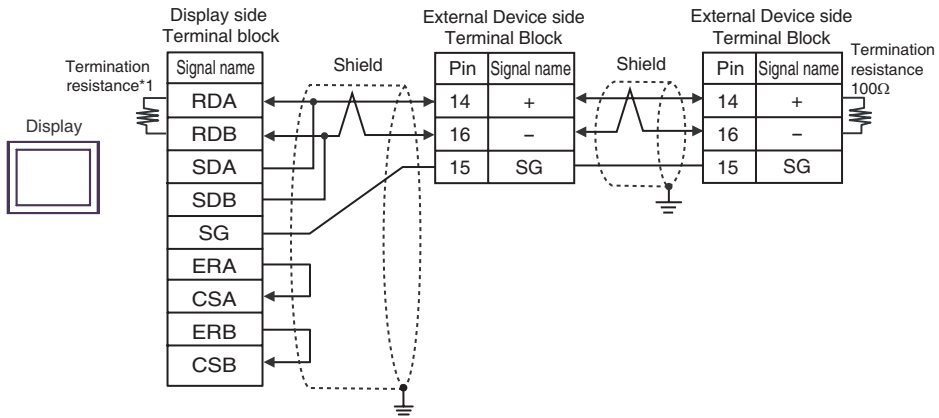

*1 The resistance in the Display is used as the termination resistance. Set the value of the DIP Switch on the rear of the Display as shown in the table below.

DIP Switch No.	Set Value
1	OFF
2	OFF
3	ON
4	ON

2H)

- 1:1 Connection

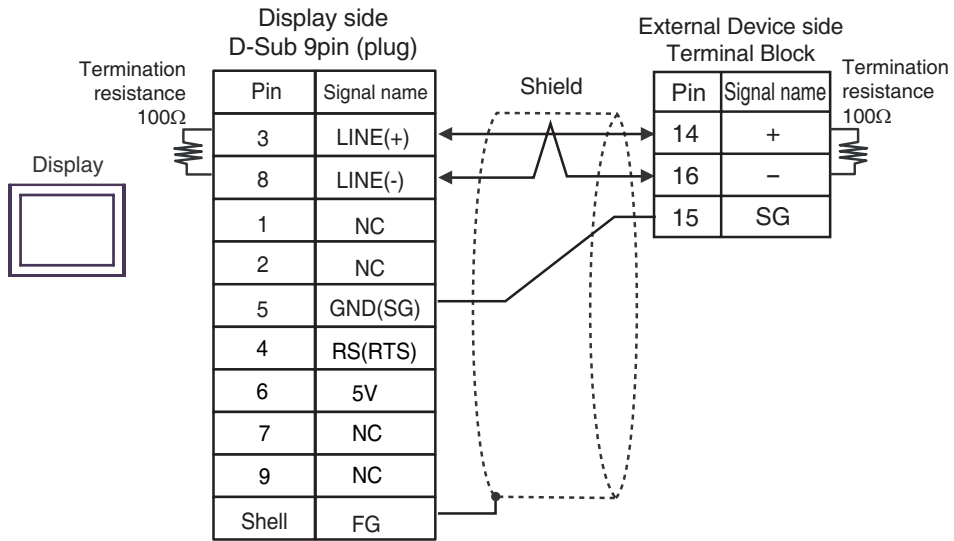

- 1:n Connection

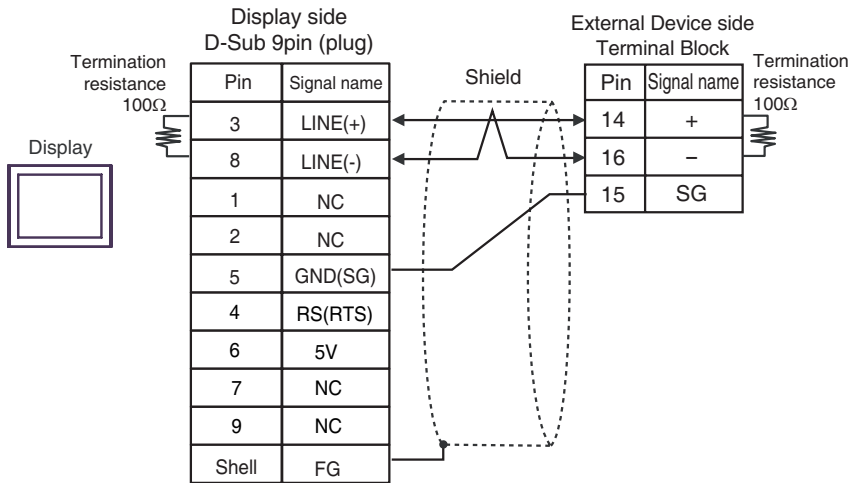

IMPORTANT

- The 5V output (Pin #6) on the GP-4107 is the power for the Siemens AG's PROFIBUS connector. Do not use it for other devices.

NOTE

- In COM on the GP-4107, the SG and FG terminals are isolated.

Cable Diagram 3

Display (Connection Port)	Cable		Notes
GP3000* ¹ (COM1) AGP-3302B (COM2) ST* ² (COM2) LT (COM1)	3A	COM port conversion adapter by Pro-face CA3-ADPCOM-01 + Terminal block conversion adapter by Pro-face CA3-ADPTRM-01 + User-created cable	Cable length: 500m or less
	3B	User-created cable	
GP3000* ³ (COM2)	3C	Online adapter by Pro-face CA4-ADPONL-01 + Terminal block conversion adapter by Pro-face CA3-ADPTRM-01 + User-created cable	
	3D	Online adapter by Pro-face CA4-ADPONL-01 + User-created cable	
IPC* ⁴	3E	COM port conversion adapter by Pro-face CA3-ADPCOM-01 + Terminal block conversion adapter by Pro-face CA3-ADPTRM-01 + User-created cable	
	3F	User-created cable	
GP-4106 (COM1)	3G	User-created cable	
GP-4107 (COM1)	3H	User-created cable	

*1 All GP3000 models except AGP-3302B

*2 All ST models except AST-3211A and AST-3302B

*3 All GP3000 models except GP-3200 series and AGP-3302B

*4 Only the COM port which can communicate by RS-422/485 (2 wire) can be used.
 "■ IPC COM Port" (page 5)

IMPORTANT

- Terminal number used for communication differs depending on the External Device series.
Terminal numbers corresponding to each series are shown below. SG terminals are not available for these series. Apply masking using insulation tape, etc. Implement Type D installment to the shield connected to the FG.

Series	+	-
PXG4	7	8
PXG5/PXG9	1	2
PXR3	15	14
PXR4/PXR7	7	8
PXR5/PXR9	1	2

3A)

- 1:1 Connection

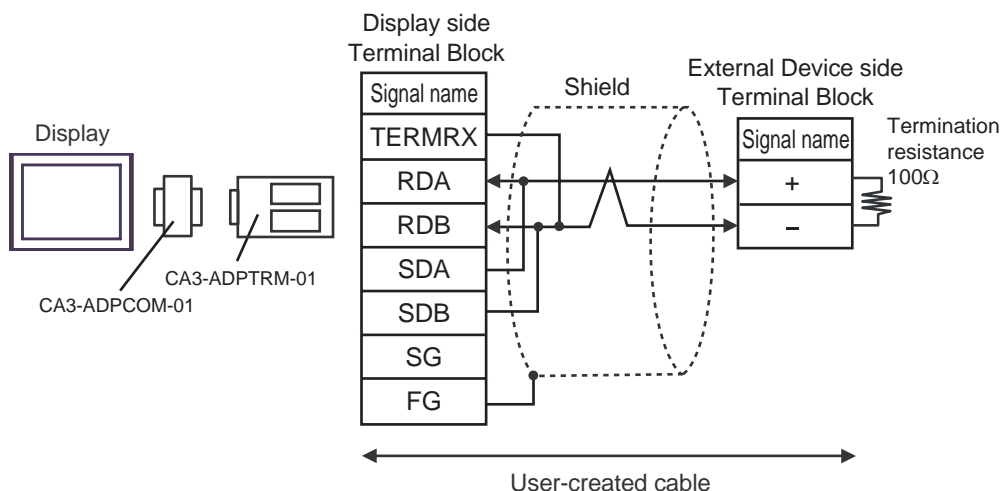

- 1:n Connection

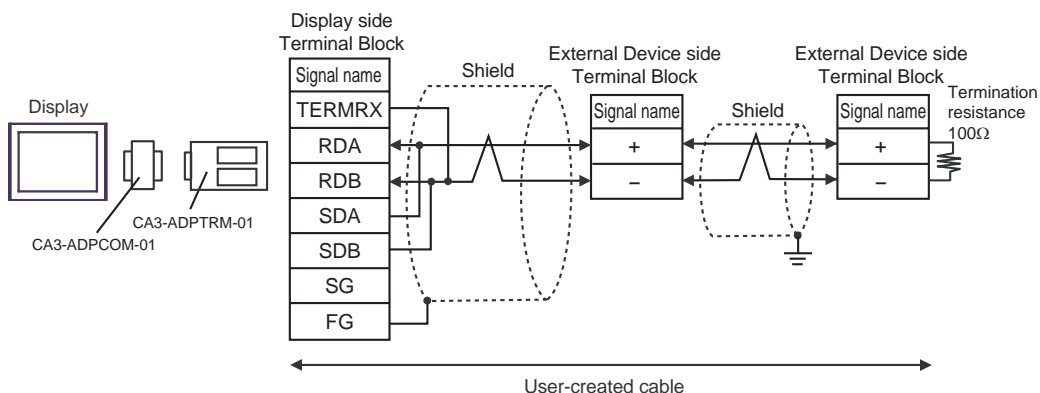

3B)

- 1:1 Connection

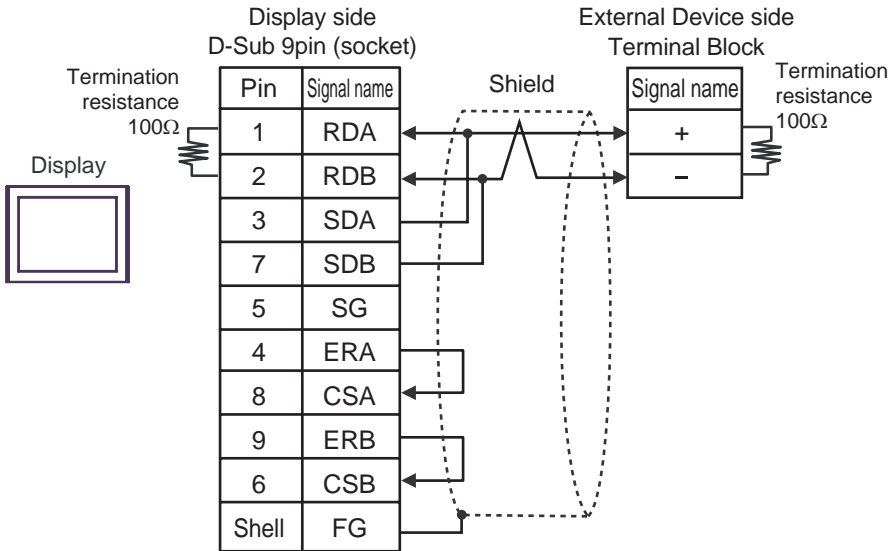

- 1:n Connection

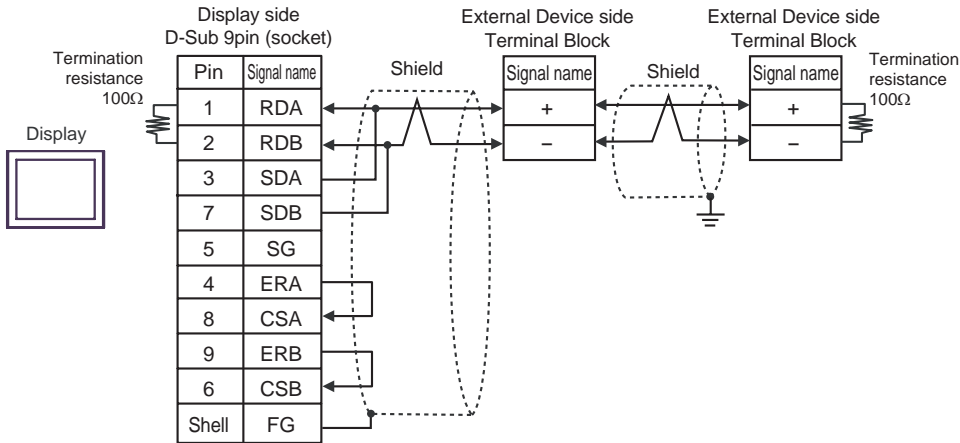

3C)

- 1:1 Connection

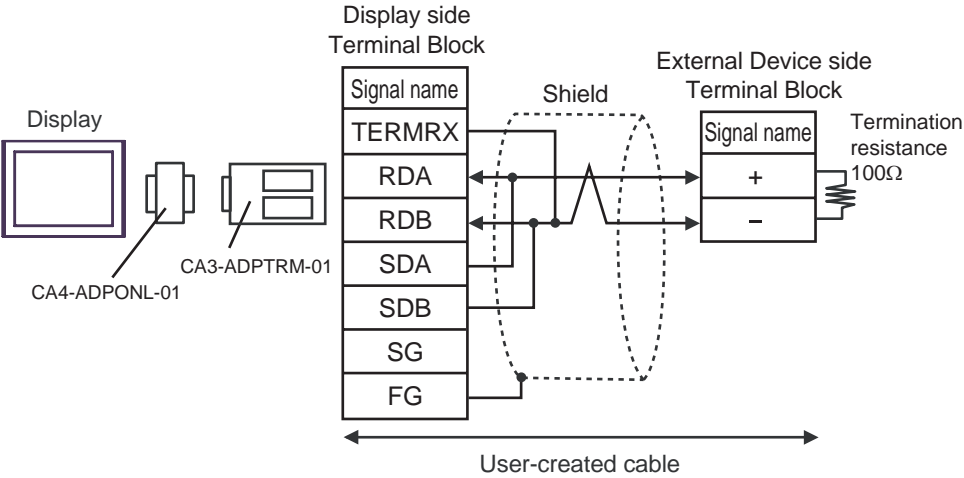

- 1:n Connection

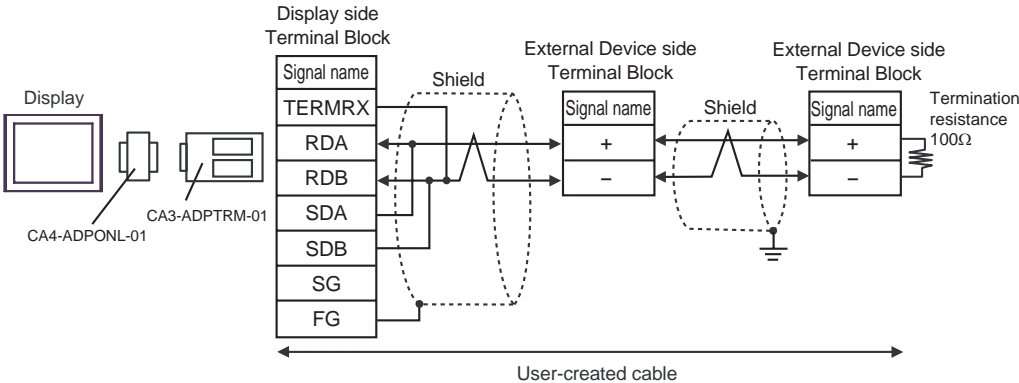

3D)

- 1:1 Connection

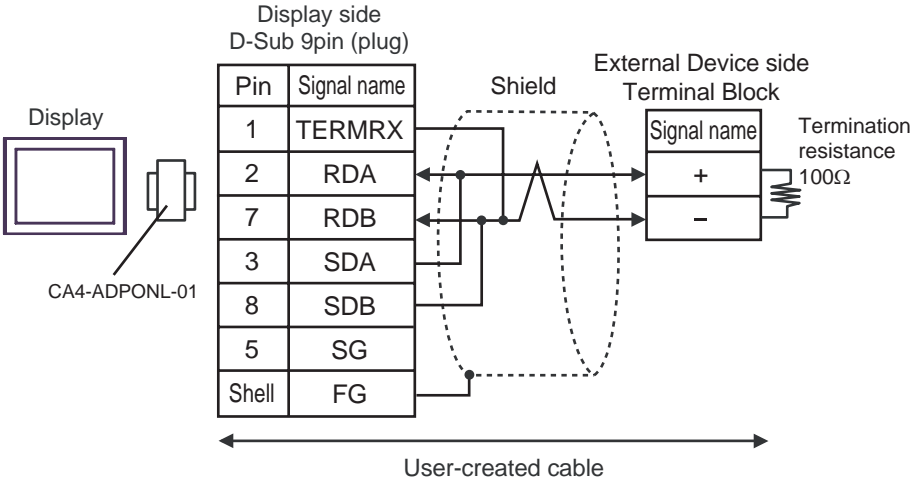

- 1:n Connection

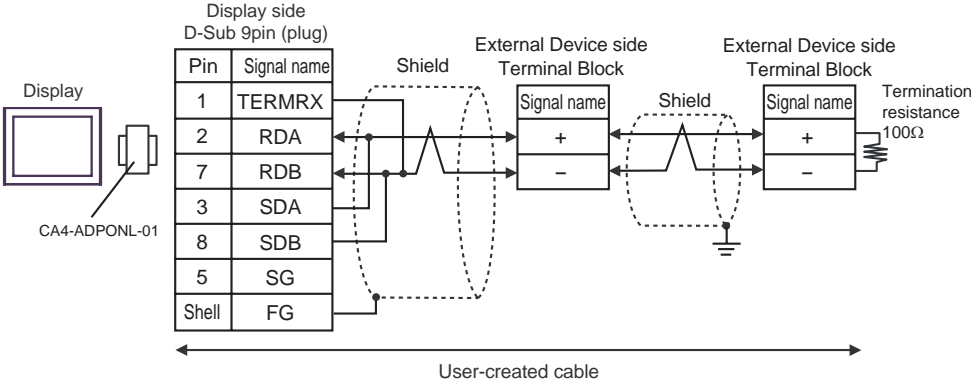

3E)

- 1:1 Connection

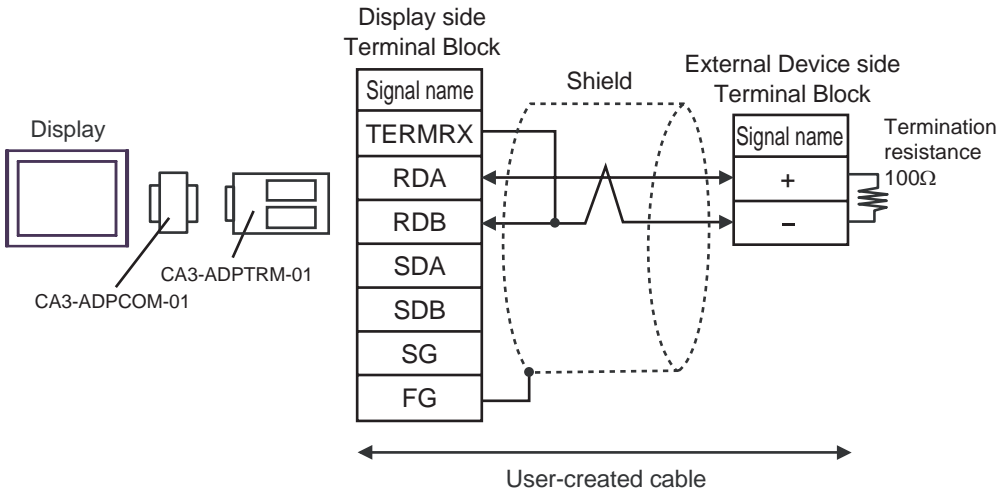

- 1:n Connection

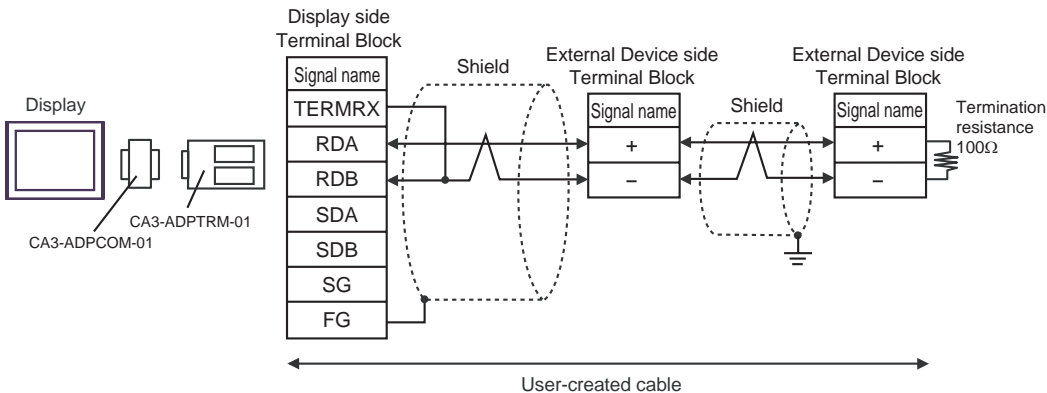

3F)

- 1:1 Connection

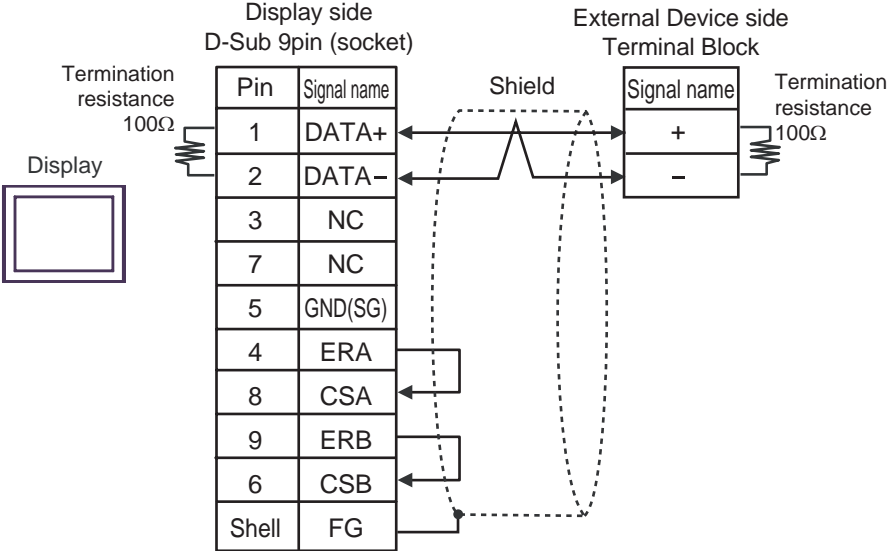

- 1:n Connection

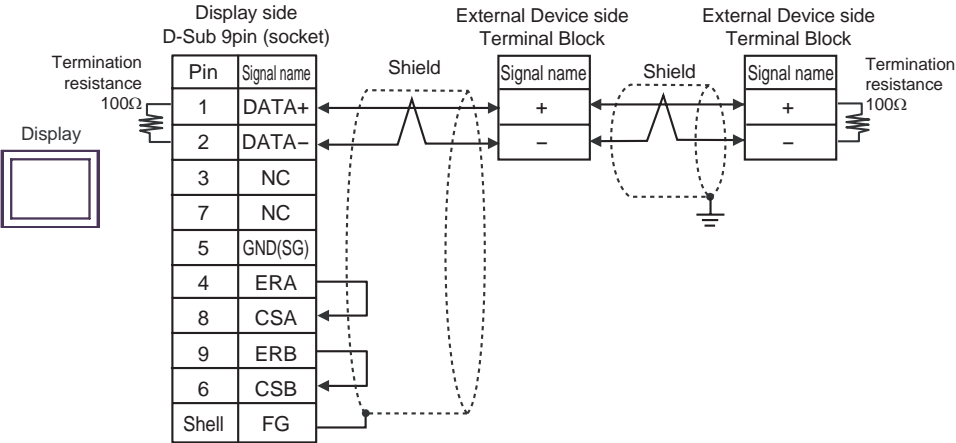

3G)

- 1:1 Connection

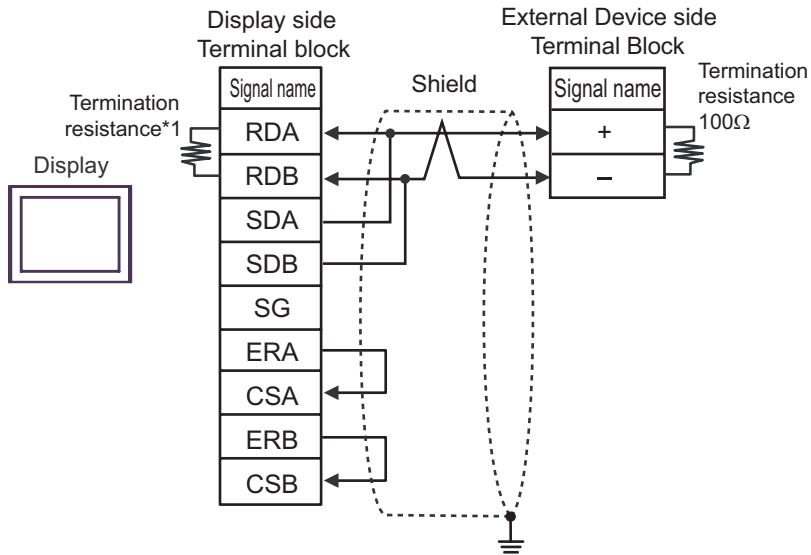

- 1:n Connection

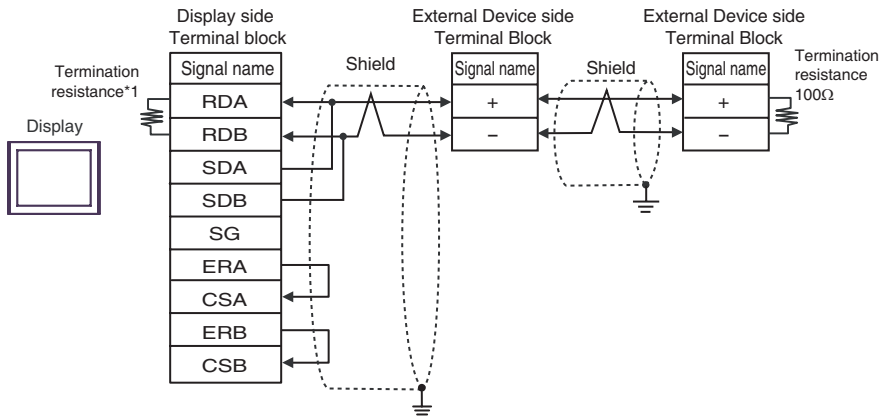

*1 The resistance in the Display is used as the termination resistance. Set the value of the DIP Switch on the rear of the Display as shown in the table below.

DIP Switch No.	Set Value
1	OFF
2	OFF
3	ON
4	ON

3H)

- 1:1 Connection

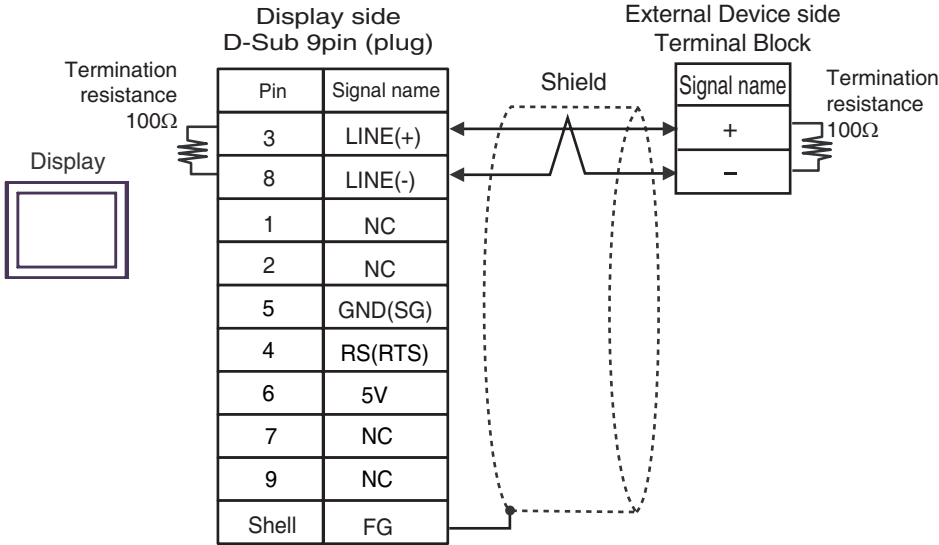

- 1:n Connection

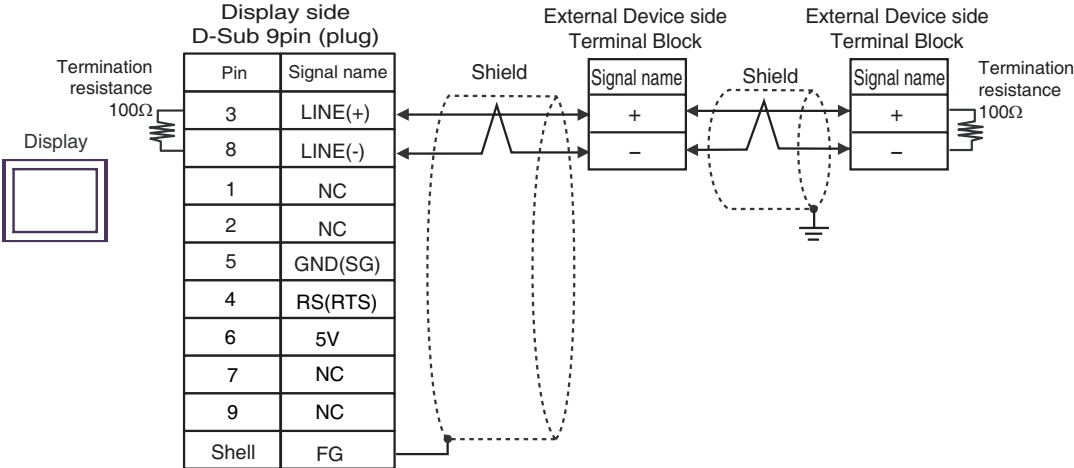

IMPORTANT • The 5V output (Pin #6) on the GP-4107 is the power for the Siemens AG's PROFIBUS connector. Do not use it for other devices.

NOTE • In COM on the GP-4107, the SG and FG terminals are isolated.

Cable Diagram 4

Display (Connection Port)	Cable		Notes
GP3000* ¹ (COM1) AGP-3302B (COM2) ST* ² (COM2) LT (COM1)	4A	COM port conversion adapter by Pro-face CA3-ADPCOM-01 + Terminal block conversion adapter by Pro-face CA3-ADPTRM-01 + User-created cable	Cable length: 500m or less
	4B	User-created cable	
GP3000* ³ (COM2)	4C	Online adapter by Pro-face CA4-ADPONL-01 + Terminal block conversion adapter by Pro-face CA3-ADPTRM-01 + User-created cable	
	4D	Online adapter by Pro-face CA4-ADPONL-01 + User-created cable	
IPC* ⁴	4E	COM port conversion adapter by Pro-face CA3-ADPCOM-01 + Terminal block conversion adapter by Pro-face CA3-ADPTRM-01 + User-created cable	
	4F	User-created cable	
GP-4106 (COM1)	4G	User-created cable	
GP-4107 (COM1)	4H	User-created cable	

*1 All GP3000 models except AGP-3302B

*2 All ST models except AST-3211A and AST-3302B

*3 All GP3000 models except GP-3200 series and AGP-3302B

*4 Only the COM port which can communicate by RS-422/485 (2 wire) can be used.
 "■ IPC COM Port" (page 5)

4A)

- 1:1 Connection

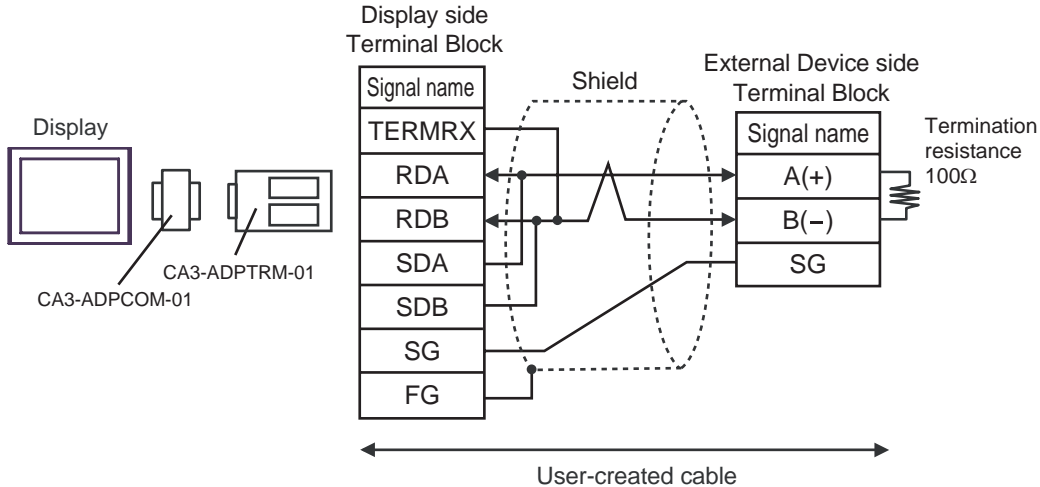

- 1:n Connection

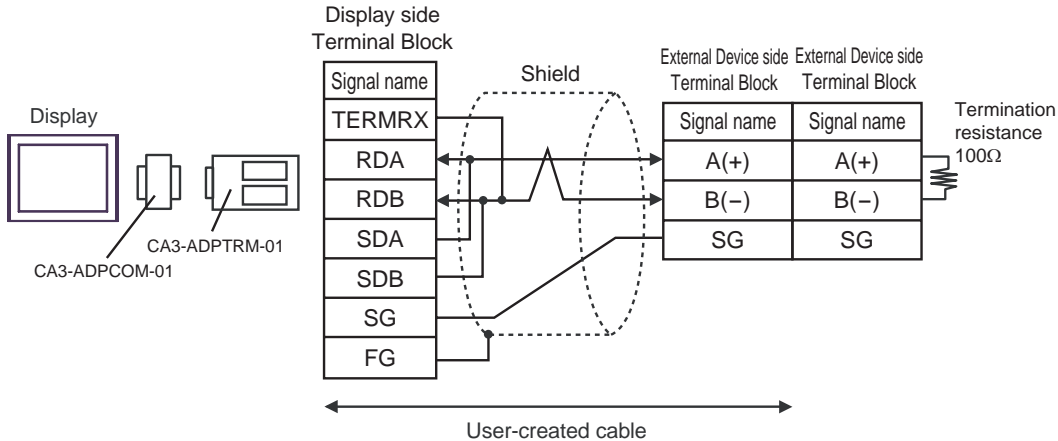

NOTE • Connect External Devices using side connectors.

4B)

- 1:1 Connection

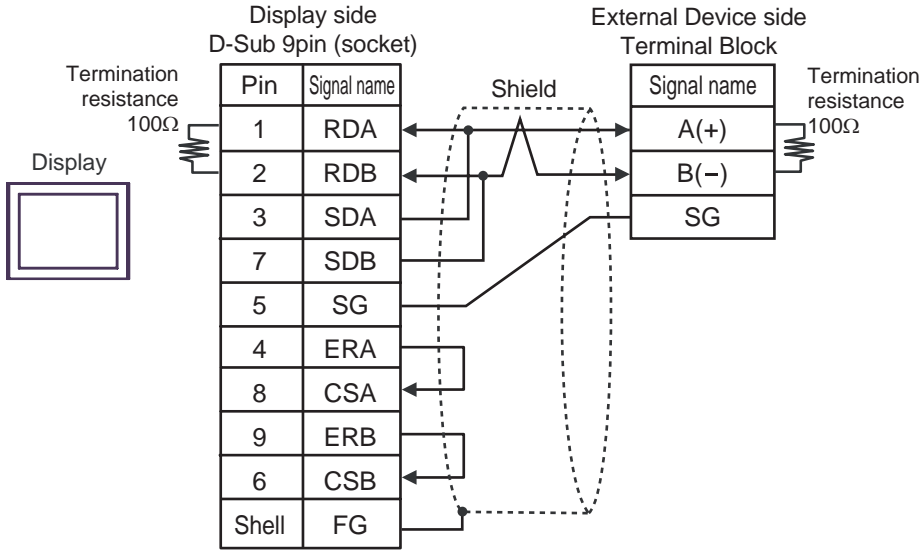

- 1:n Connection

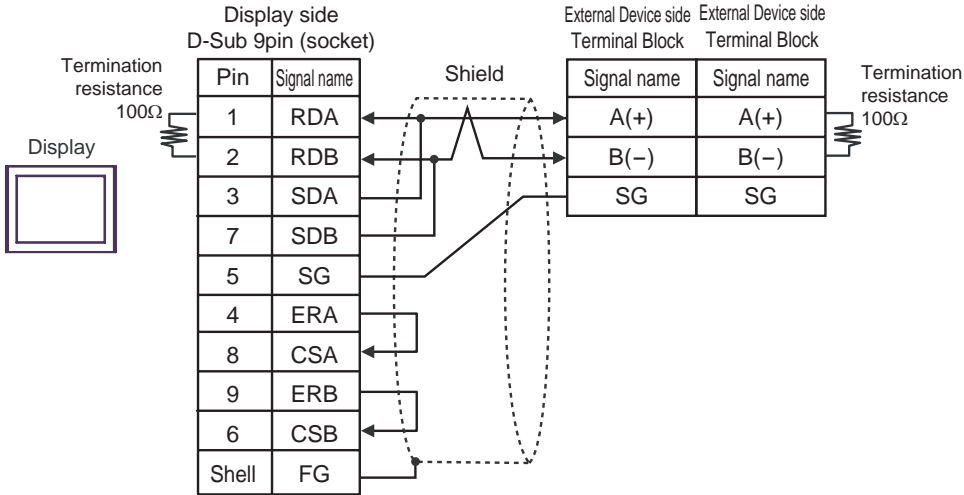

NOTE • Connect External Devices using side connectors.

4C)

- 1:1 Connection

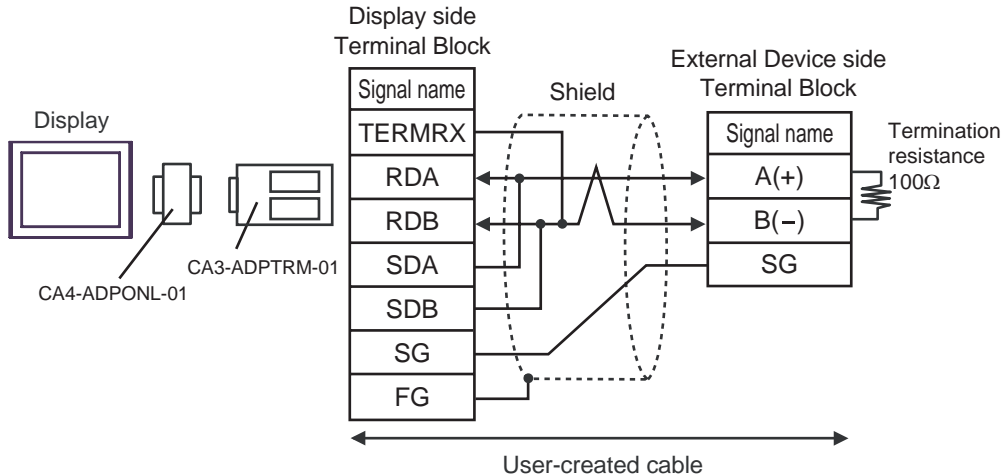

- 1:n Connection

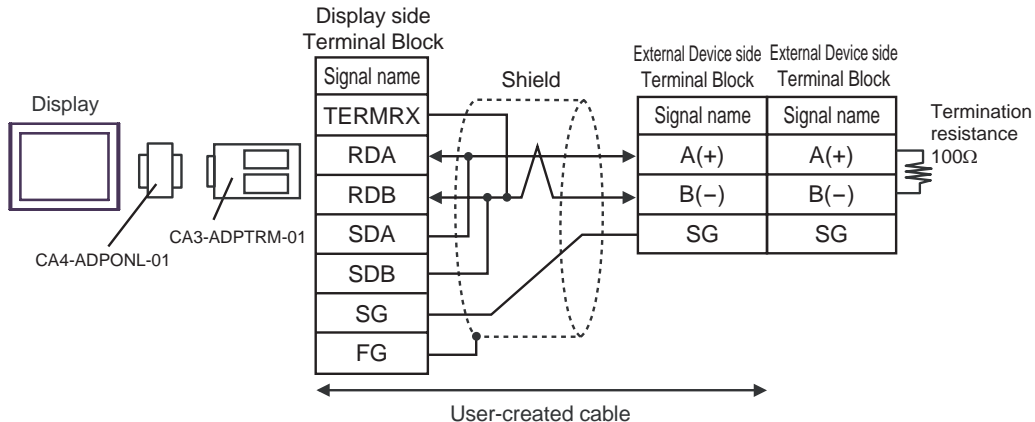

NOTE

- Connect External Devices using side connectors.

4D)

- 1:1 Connection

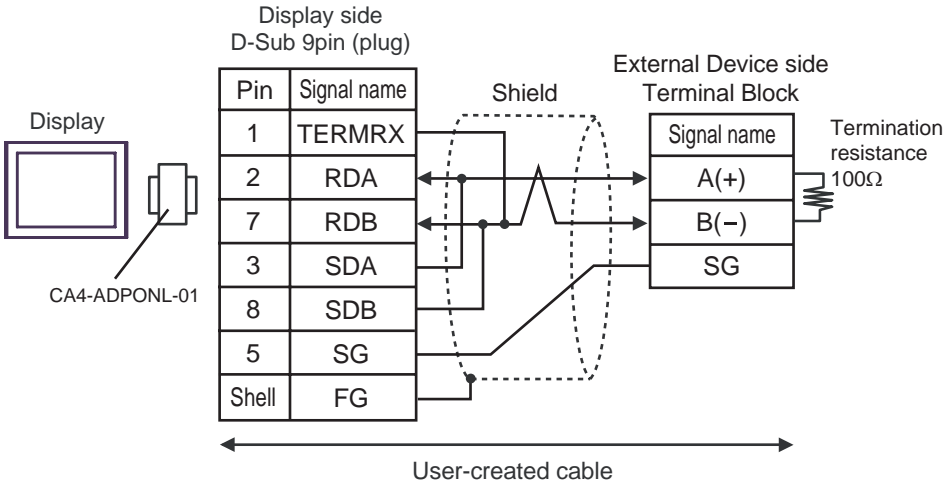

- 1:n Connection

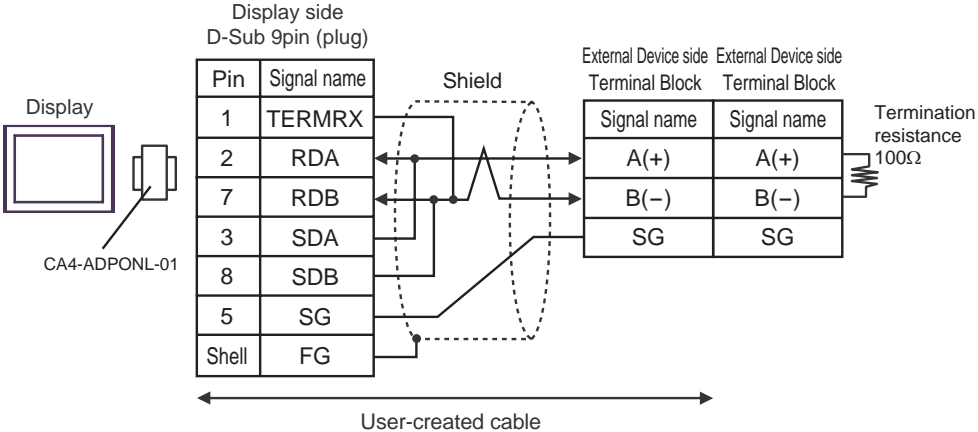

NOTE • Connect External Devices using side connectors.

4E)

- 1:1 Connection

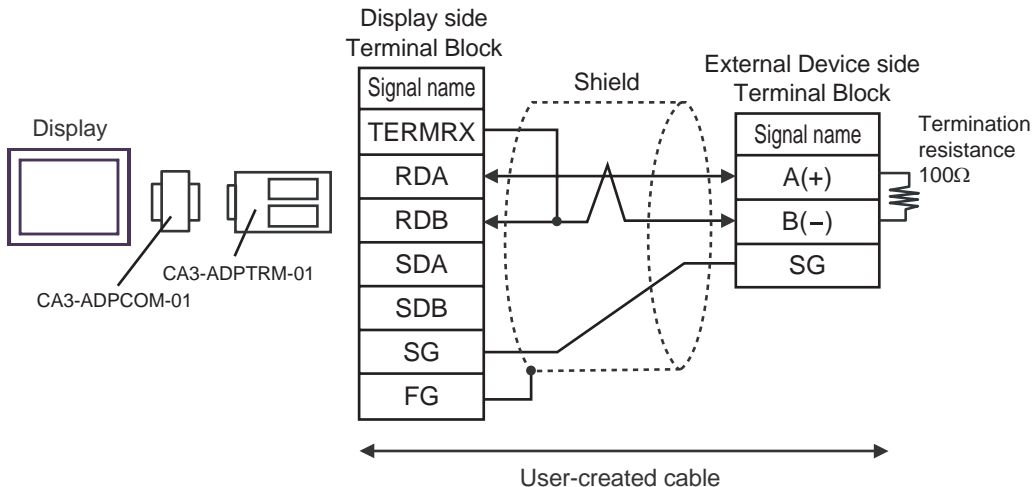

- 1:n Connection

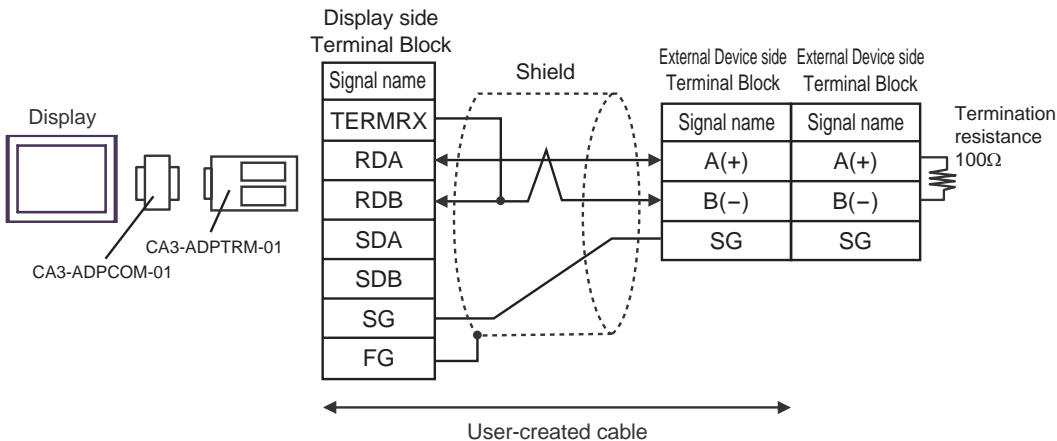

NOTE • Connect External Devices using side connectors.

4F)

- 1:1 Connection

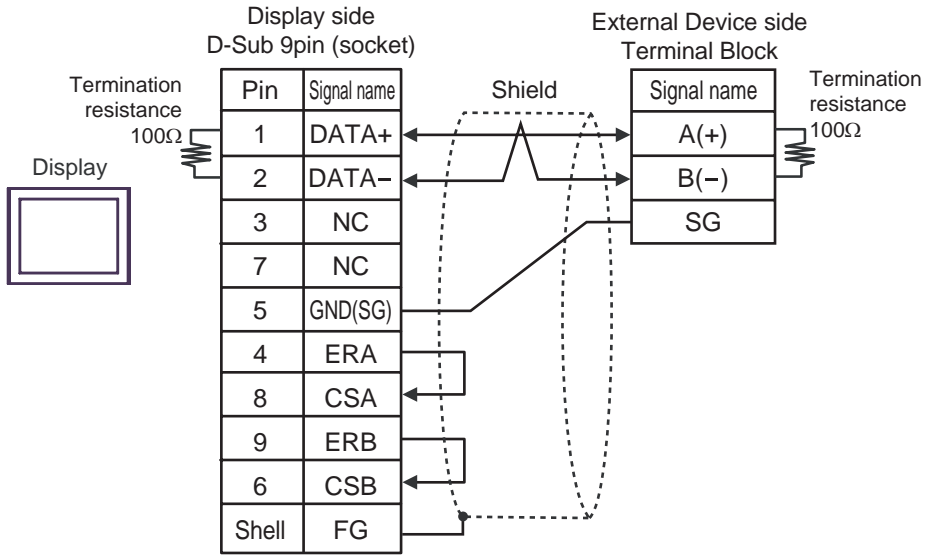

- 1:n Connection

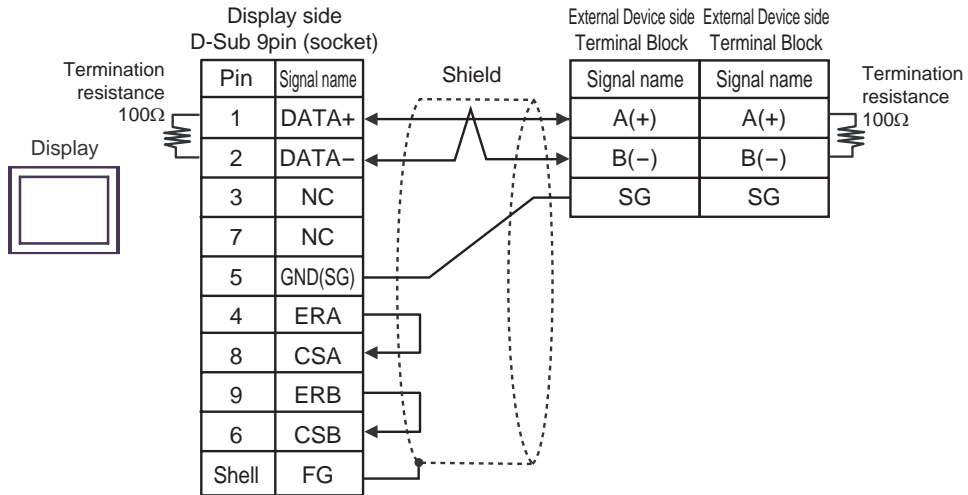

NOTE

- Connect External Devices using side connectors.

4G)

- 1:1 Connection

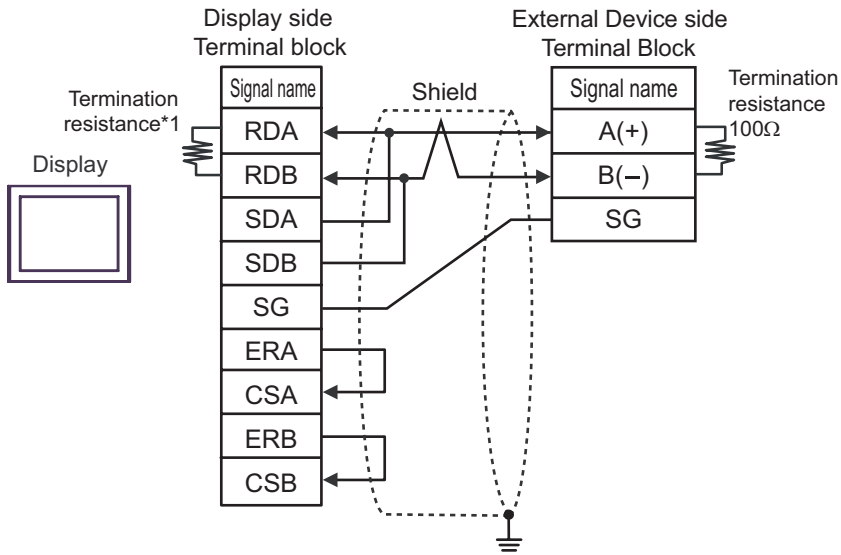

- 1:n Connection

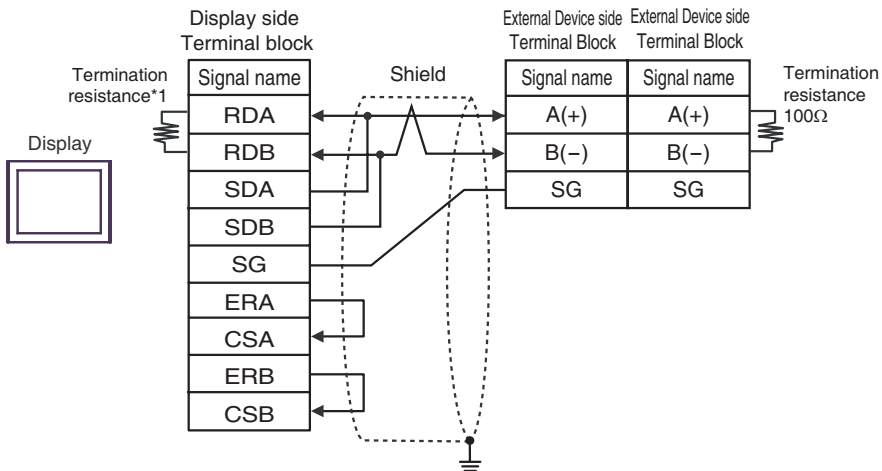

NOTE

- Connect External Devices using side connectors.

*1 The resistance in the Display is used as the termination resistance. Set the value of the DIP Switch on the rear of the Display as shown in the table below.

DIP Switch No.	Set Value
1	OFF
2	OFF
3	ON
4	ON

4H)

- 1:1 Connection

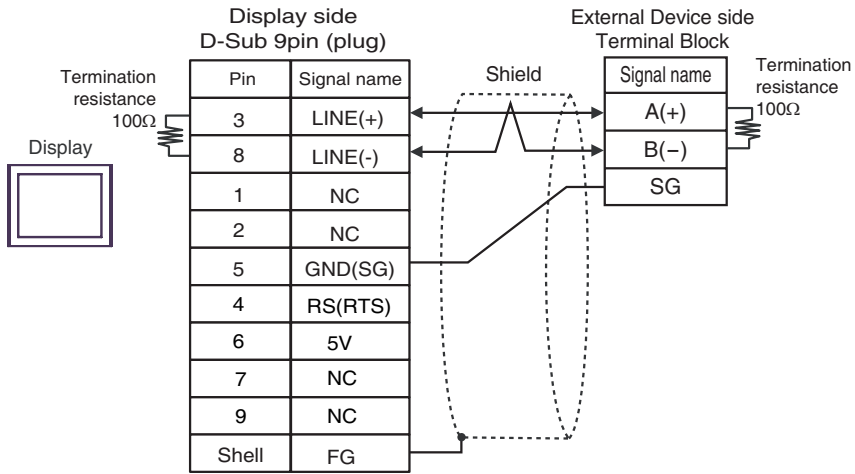

- 1:n Connection

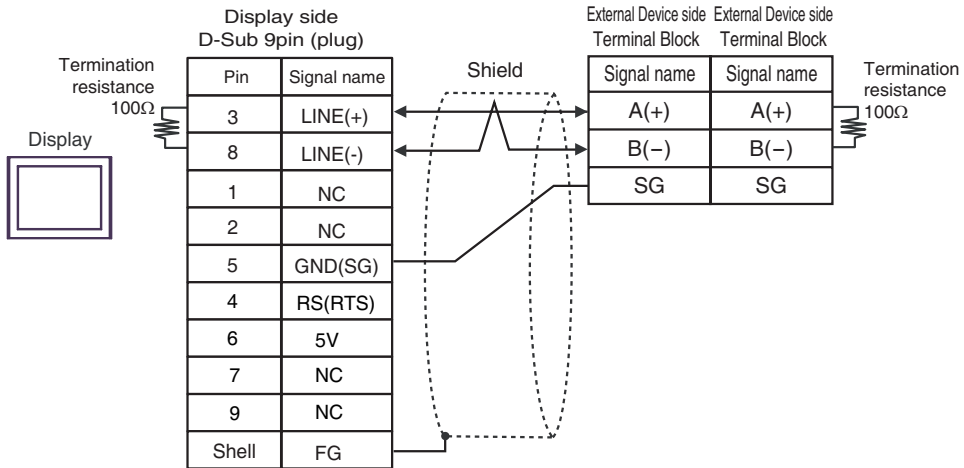

IMPORTANT

- The 5V output (Pin #6) on the GP-4107 is the power for the Siemens AG's PROFIBUS connector. Do not use it for other devices.

NOTE

- Connect External Devices using side connectors.
- In COM on the GP-4107, the SG and FG terminals are isolated.

6 Supported Devices

The following table shows the range of supported device addresses. Please note that the actually supported range of the devices varies depending on the External Device to be used. Please check the actual range in the manual of your External Device.

Input address of external device in the dialog below.

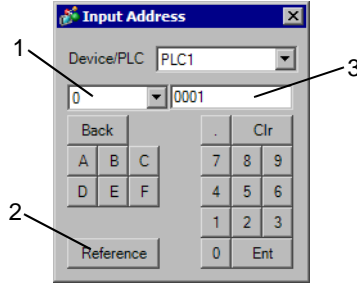

1. Device Set Device.
2. Reference The list of available identifiers is displayed.
Click the identifier to use and press "Select," and the address is entered.
3. Address Set Address.
The combination of identifier and address differs depending on the external device.

■The following description explains the memory maps for each parameter.

<When using Bit Data>

Bit Data (Read Only) : Function [02H]

Relative Address	Coil No. *1	Type	Memory Contents	Read-out Data
0000H	10001	Bit	Alarm1 ON/OFF	0: Alarm1 OFF, 1: Alarm1 ON
0001H	10002		(Reserved)	
0002H	10003		(Reserved)	
0003H	10004		(Reserved)	
0004H	10005	Bit	Alarm2 ON/OFF	0: Alarm2 OFF, 1: Alarm2 ON
0005H	10006		(Reserved)	
:	:	:	:	:

*1 Coil No. is the address that is assigned by the Display.

Example: For the parameter "Alarm1 ON/OFF" of Coil No. 10001, the Display's designated address is as follows.

Use the first digit of the Coil No. (00001 -, 10001 -) to designate the device.

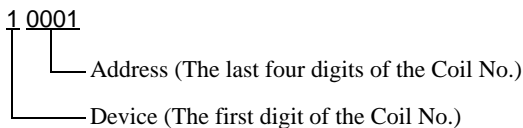

Example: For the parameter "front surface control SV data" of Register No. 41003, the Display's designated address is as follows. Use the first two digits of the Register No.s (30001 -, 40001 -, 31001 - and 41001 -) to designate the device.

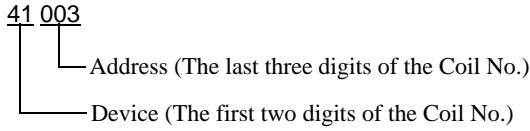

NOTE



- The External Device's parameter data, when data transfer is performed, will have no decimal places. Thus, in the Display, processing must be performed to correct the data. For example, if a numeric display is used that includes decimal places, the "No. of Decimals" of the "Display" settings must be used. Also, when writing data to a External Device, it is necessary to write decimal values as integers.

Example: Register No. 41025's "Output 1 Lower Limit"
 External Device Display/Setting Value : 3.00%
 Display value/setting : 3000

Please refer to your External Device manual for details (with/without a decimal point) about data item setting value ranges.

6.1 PXH series

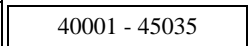
 This address can be specified as system data area.

Device	Bit Address	Word Address	32bits	Notes
Read Only Word Data	-	30257 - 31407	H/L	 *1*2
Word Data	40001.00 - 45035.31	 40001 - 45035		 *2*3*4





- *1 Write disabled.
- *2 This device is 32 bits in length. Only odd addresses can be assigned.
- *3 When you write to the bit address, the Display reads the entire word, sets the defined bit, then returns the new word value to the External Device. If the ladder program writes data to this word address during the bit write process, the resulting data may be incorrect.
- *4 43153 is an address to order writing in the nonvolatile memory (FIX processing). Writing in the nonvolatile memory is performed by entering 1 (one) to the writing value.

NOTE

- You can only set the Read Area Size for the system area available to use in the External Device. Please refer to the GP Pro-EX Reference Manual for Read Area Size. Cf. GP Pro-EX Reference Manual "LS Area (Direct Access Method)"
 - Refer to the precautions on manual notation for icons in the table.
-  "Manual Symbols and Terminology"

6.2 PXG series

 This address can be specified as system data area.

Device	Bit Address	Word Address	32bits	Notes
Read Only Bit Data	10001 - 10013	-		*1
Read Only Word Data (Internal)	-	30001 - 30062		 *1
Read Only Word Data (Engineering Unit)	-	31001 - 31062		 *1
Word Data (Internal)	40002.00 - 40628.15	40002 - 40628		 *2
Word Data (Engineering Unit)	41002.00 - 41628.15	41002 - 41628		 *2

*1 Write disabled.

*2 When you write to the bit address, the Display reads the entire word, sets the defined bit, then returns the new word value to the External Device. If the ladder program writes data to this word address during the bit write process, the resulting data may be incorrect.







NOTE

- You can only set the Read Area Size for the system area available to use in the External Device. Please refer to the GP Pro-EX Reference Manual for Read Area Size.
Cf. GP Pro-EX Reference Manual "LS Area (Direct Access Method)"
- Refer to the precautions on manual notation for icons in the table.

 "Manual Symbols and Terminology"

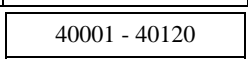
6.3 PXR (AutoFIX) / PXR (NoAutoFIX) series

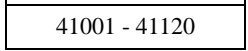
 This address can be specified as system data area.

Device	Bit Address	Word Address	32bits	Notes
Bit Data	00001	-	H/L	*1
Read Only Bit Data	10001 - 10016	10001		 *2
Read Only Word Data (Internal)	-	30001 - 30037		 *2
Read Only Word Data (Engineering Unit)	-	31001 - 31037		 *2
Word Data (Internal)	40001.00 - 40120.15	 40001 - 40120		 *1*3
Word Data (Engineering Unit)	41001.00 - 41120.15	 41001 - 41120		 *1*3



- *1 00001, 40001, and 41001 are addresses to order writing in the nonvolatile memory (FIX processing). Writing in the nonvolatile memory is performed by entering 1 (one) to the writing value.
- *2 Write disabled.
- *3 When you write to the bit address, the Display reads the entire word, sets the defined bit, then returns the new word value to the External Device. If the ladder program writes data to this word address during the bit write process, the resulting data may be incorrect.

NOTE

- You can only set the Read Area Size for the system area available to use in the External Device. Please refer to the GP Pro-EX Reference Manual for Read Area Size.
Cf. GP Pro-EX Reference Manual "LS Area (Direct Access Method)"
- Refer to the precautions on manual notation for icons in the table.
 "Manual Symbols and Terminology"

6.4 PUM series (PUMA / B)

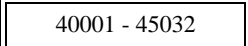
 This address can be specified as system data area.

Device	Bit Address	Word Address	32bits	Notes
Read Only Word Data	-	30001 - 34061	H/L	 *1
Word Data	40001.00 - 45032.15	 40001 - 45032		 *2





- *1 Write disabled.
- *2 When you write to the bit address, the Display reads the entire word, sets the defined bit, then returns the new word value to the External Device. If the ladder program writes data to this word address during the bit write process, the resulting data may be incorrect.

NOTE

- You can only set the Read Area Size for the system area available to use in the External Device. Please refer to the GP Pro-EX Reference Manual for Read Area Size.
Cf. GP Pro-EX Reference Manual "LS Area (Direct Access Method)"
- Refer to the precautions on manual notation for icons in the table.
 "Manual Symbols and Terminology"

6.5 PUM series (PUME)

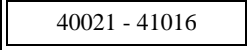
 This address can be specified as system data area.

Device	Bit Address	Word Address	32bits	Notes
Read Only Word Data	-	30064 - 31003		 *1
Word Data	40021.00 - 41016.15	 40021 - 41016		 *2

*1 Write disabled.

*2 When you write to the bit address, the Display reads the entire word, sets the defined bit, then returns the new word value to the External Device. If the ladder program writes data to this word address during the bit write process, the resulting data may be incorrect.





NOTE

- You can only set the Read Area Size for the system area available to use in the External Device. Please refer to the GP Pro-EX Reference Manual for Read Area Size.
Cf. GP Pro-EX Reference Manual "LS Area (Direct Access Method)"
- Refer to the precautions on manual notation for icons in the table.

 "Manual Symbols and Terminology"

6.6 PUM series (PUMV / N / T)

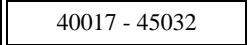
 This address can be specified as system data area.

Device	Bit Address	Word Address	32bits	Notes
Read Only Word Data	-	30001 - 34061		 *1
Word Data	40017.00 - 45032.15	 40017 - 45032		 *2

*1 Write disabled.

*2 When you write to the bit address, the Display reads the entire word, sets the defined bit, then returns the new word value to the External Device. If the ladder program writes data to this word address during the bit write process, the resulting data may be incorrect.

NOTE

- You can only set the Read Area Size for the system area available to use in the External Device. Please refer to the GP Pro-EX Reference Manual for Read Area Size.
Cf. GP Pro-EX Reference Manual "LS Area (Direct Access Method)"
- Refer to the precautions on manual notation for icons in the table.

 "Manual Symbols and Terminology"

7 Device Code and Address Code

Use device codes and address codes when you set "Device Type & Address" for the address type of the data display or other devices.

7.1 PXH series

Device	Device Name	Device Code (HEX)	Address Code
Read Only Word Data	3	0001	Value of (word address - 1) divided by 2
Word Data	4	0000	Value of (word address - 1) divided by 2

7.2 PXG series

Device	Device Name	Device Code (HEX)	Address Code
Read Only Word Data (Internal)	30	0001	Value of (word address - 1)
Read Only Word Data (Engineering Unit)	31	0003	Value of (word address - 1)
Word Data (Internal)	40	0000	Value of (word address - 1)
Word Data (Engineering Unit)	41	0002	Value of (word address - 1)

7.3 PXR (AutoFIX) / PXR (NoAutoFIX) series

Device	Device Name	Device Code (HEX)	Address Code
Read Only Word Data (Internal)	30	0001	Value of (word address - 1)
Read Only Word Data (Engineering Unit)	31	0003	Value of (word address - 1)
Word Data (Internal)	40	0000	Value of (word address - 1)
Word Data (Engineering Unit)	41	0002	Value of (word address - 1)

7.4 PUM series

Device	Device Name	Device Code (HEX)	Address Code
Read Only Word Data	3	0001	Value of (word address - 1)
Word Data	4	0000	Value of (word address - 1)

8 Error Messages

Error messages are displayed on the Display screen as follows: "No. : Device Name: Error Message (Error Occurrence Area)". Each description is shown below.

Item	Description
No.	Error number
Device Name	Name of the External Device where an error has occurred. Device/PLC name is the title of the External Device set with GP Pro-EX. (Initial value [PLC1])
Error Message	Displays messages related to an error that has occurred.
Error Occurrence Area	Displays the IP address or device address of the External Device where an error has occurred, or error codes received from the External Device. NOTE <ul style="list-style-type: none"> • IP address is displayed as "IP address (Decimal): MAC address (Hex)". • Device address is displayed as "Address: Device address". • Received error codes are displayed as "Decimal [Hex]".

Examples of Error Messages

"RHAA035:PLC1: Error has been responded for device write command (Error Code: 2 [02H])"

NOTE

- Refer to your External Device manual for details on received error codes.
- Refer to "When an error is displayed (Error Code List)" in "Maintenance/Troubleshooting Manual" for details on the error messages common to the driver.

■ Error Codes Unique to External Device

Error Code	Description
0x02	Faulty address for coil or resistor
0x06	Busy condition