

# PCMCIA Card Adaptor Unit (PSG-PCM00) Installation Guide

Thank you for purchasing Pro-face's PCMCIA Card Adaptor Unit (PSG-PCM00), hereafter referred to as the "PCMCIA unit". This unit is designed to be attached to the rear face of a PS-400G Series, or a PS-600G Series unit (hereafter referred to collectively as the "PS-G"). Once the unit is attached, a PCMCIA Card can be inserted in the PCMCIA unit.

Corresponding PS-G units: PS-400G Series, PS-600G Series units

*(All product names that appear in this guide are the trademarks of their respective companies)*

*Pro-face: Digital Electronics Corporation (in Japan and other countries)*

*Windows®CE: Microsoft Corporation (USA)*

## Safety Precautions

This Installation Guide includes important safety-related information that must be followed to ensure the correct and safe use of the PCMCIA unit. Prior to operating this unit, be sure to read both this guide and any related manuals to thoroughly understand the correct operation and functions of both the PCMCIA and PS-G units.

### ■ Safety Icons

Throughout this manual the following icons are used to indicate procedures requiring special attention to safety.

These icons have the following meaning:



Indicates situations where severe bodily injury, death or major machine damage can occur.



Indicates situations where bodily injury or machine damage can occur.

## WARNINGS

- Installing the PCMCIA unit while power is supplied to the PS-G may lead to an electric shock. Prior to installing the PCMCIA unit, confirm that the PS-G unit's power supply is disconnected.
- Do not attempt to open or modify the PCMCIA unit. Doing so may lead to a fire or electric shock.
- Prior to installing the PCMCIA unit, carefully read Section 3. Installation.

### ■ To Prevent Unit Failure

- Since the PCMCIA unit is a precision device, do not subject it to shocks or excessive vibration.
- Be sure that no water, liquid or metal particles are adhering to the PCMCIA unit, since they can cause unit failure or an electric shock.
- Do not operate or store the PCMCIA unit in locations exposed to direct sunlight, high temperatures or dust.
- Do not operate or store the PCMCIA unit in locations where vaporized chemicals are present in the air, or where chemicals may contact the unit.
- Do not attempt to open or modify the PCMCIA unit.
- Do not use the PCMCIA unit where corrosive gasses are present.

## Package Contents

The PCMCIA unit's package includes the following items. Prior to using the unit, be sure to check that all the items are included in the package.

### ■ PCMCIA Card Adaptor Unit: 1

(Model No. PSG-PCM00)

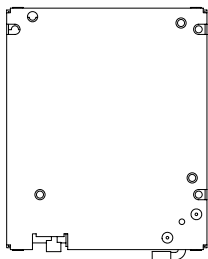

### ■ Installation Guide: 1 (this manual)

Installation guide for the PCMCIA card adaptor unit

### ■ Attachment screws: 4



Pro-face has thoroughly inspected this package's contents and quality prior to shipping. If, however, any of the items listed here is broken or missing, or you have any comments regarding the product, immediately contact your local Pro-face distributor.

# 1 External Drawings and Dimensions

## ■ PCMCIA Unit

Unit: mm [in.]

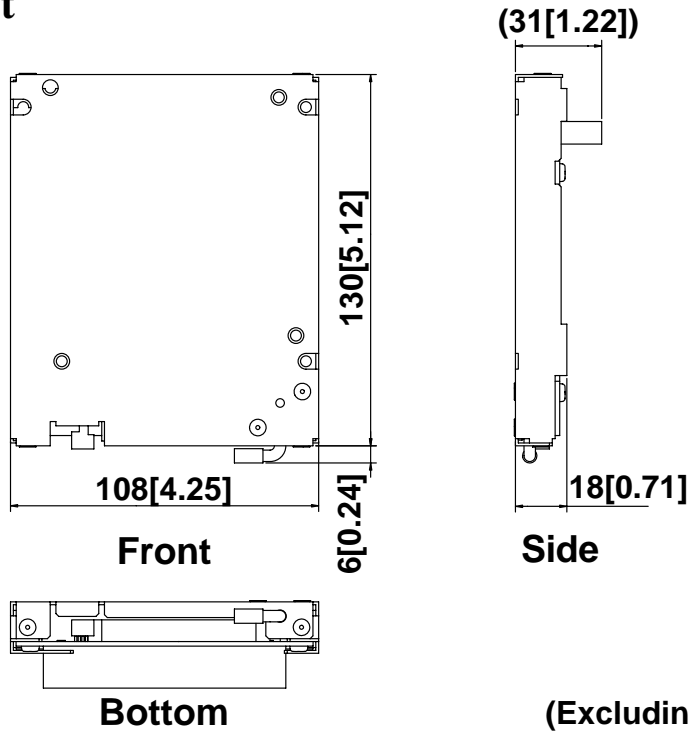

## ■ PS-G Units (with PCMCIA unit attached)

### ◆ PS-400G Unit

Unit: mm [in.]

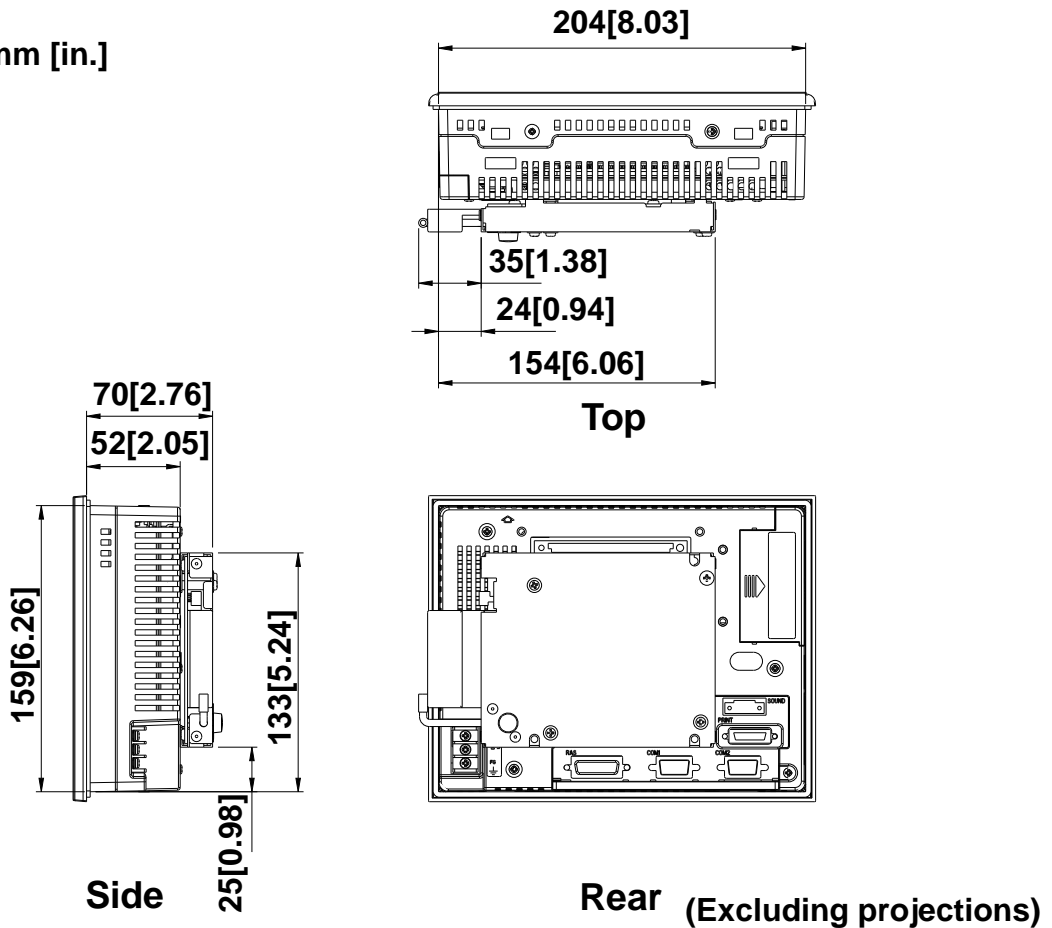

## ◆ PS-600G Unit

Unit: mm [in.]

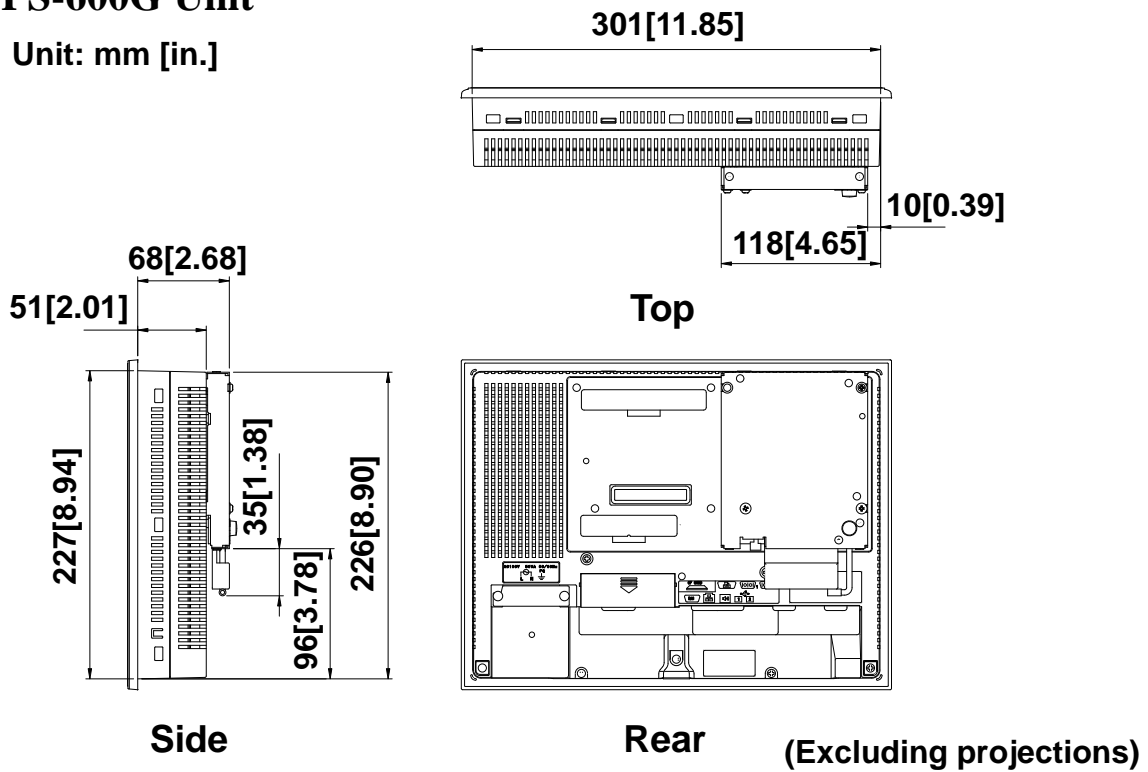

## 2 Specifications

### ■ Environmental

Ambient operating temperature	0 to 50°C
Storage temperature	-20 to +60°C
Ambient humidity	10 to 90%RH (non-condensing)
Dust	0.1 mg/m <sup>3</sup> or less
Atmosphere	Free of corrosive gasses
Vibration resistance	<p>Conforms to JIS B 3501 and IEC61131-2.</p> <p>When intermittent vibration is present:</p> <p>10 to 57 Hz, 0.075 mm</p> <p>57 to 150 Hz, 9.8 m/s<sup>2</sup></p> <p>When continuous vibration is present:</p> <p>10 to 57 Hz, 0.035 mm</p> <p>57 to 150 Hz, 4.9 m/s<sup>2</sup></p> <p>10 times in X, Y, and Z directions (for 80 min.)</p>

\* If the operating temperature range of your PCMCIA card is narrower than 0°C to 50°C, be sure to operate the combination of the PCMCIA card unit and the PS-G unit only within the PCMCIA card's narrower operating temperature range.

\*The specifications given above are only for the PCMCIA unit. Be sure to check the environmental specifications of the PCMCIA card you use and use the PCMCIA unit only within the PCMCIA card's specification range.

### ■Functional

Support card specification	PCMCIA Type II EXTEND
Applicable card voltage	PCMCIA card with power supply specification of 3.3 V or 5 V
Applicable cards	ATA card, SRAM card, Serial card
Maximum dimension of usable card	Direction of card insertion/ejection: Up to 117 mm [4.61 in.]

### ■Structural

External dimensions	W130 [5.12] x H108 [4.25] x D18 [0.71] mm [in.] (Main body only excluding projections and connector)
Weight	Approx. 270 g

## 3 Installation

Follow the procedures given below to attach the PCMCIA unit to the PS-G.

### WARNINGS

- Installing the PCMCIA unit while power is supplied to the PS-G may lead to an electric shock. Prior to installing the PCMCIA unit, confirm that the PS-G unit's power supply is disconnected.
- Do not touch the inside face of the circuit board. Also, be sure to wear gloves to prevent cuts.

- 1) Turn the power supply to the PS-G OFF.
- 2) Remove the PS-G rear face's expansion unit I/F 2 (EXT2) connector cover.

**PS-400G**

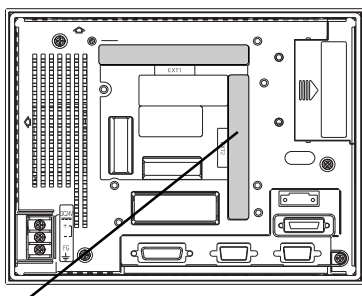

**Expansion Unit I/F 2 (EXT2)  
Connector Cover**

**PS-600G**

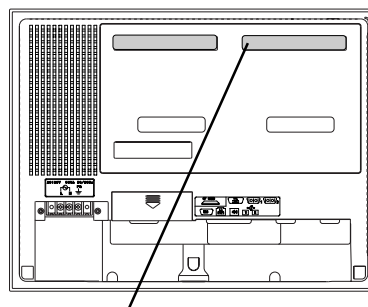

**Expansion Unit I/F 2 (EXT2)  
Connector Cover**

- 3) Attach the PCMCIA unit's connector to expansion unit I/F 2 (EXT2).
- 4) Insert the attachment screws into the PCMCIA unit's four threaded holes, and secure the unit to the PS-G.

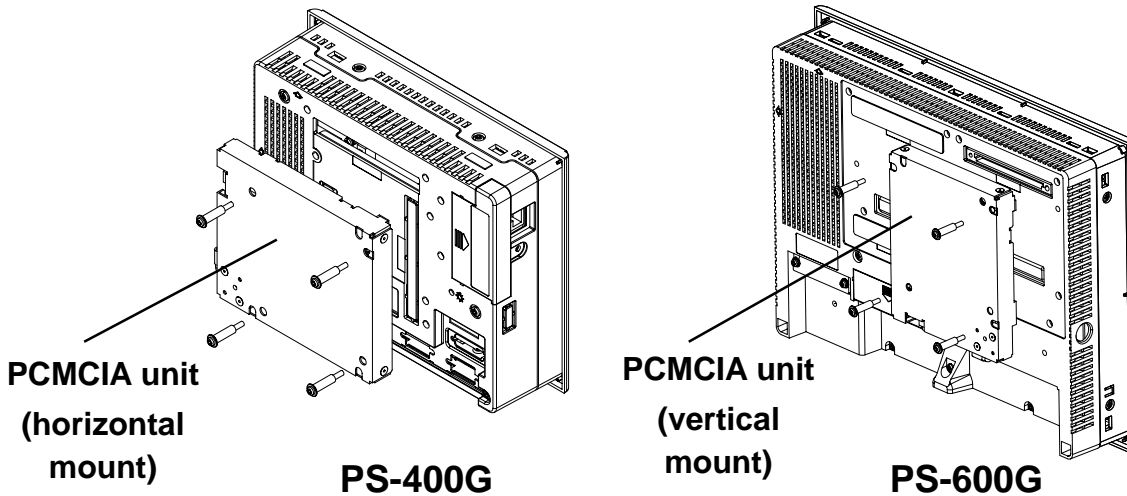

- Excessive screw torque can damage the PCMCIA unit. A torque is 0.5 to 0.6 N•m is sufficient.



- The installation direction and attachment screw positions are different on the PS-400G and the PS-600G. Confirm each prior to attaching the unit.

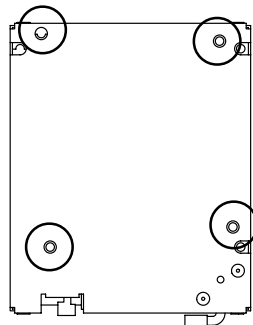

PS-400G Screw Positions

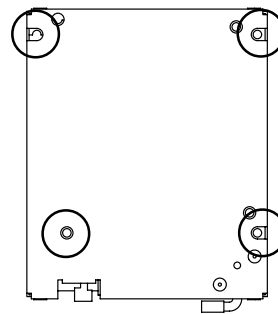

PS-600G Screw Positions

## 4 PCMCIA Card Cautions



### CAUTION

- Prior to inserting the PCMCIA card, be sure to check its orientation. If the card is inserted in the incorrect direction, both the PCMCIA card and the card's data may be damaged.
- Be sure to always push the PCMCIA card eject button to remove the card. If the PCMCIA card is removed manually, both the PCMCIA card and the PCMCIA unit can be damaged.



## CAUTIONS

- While the PS-G unit is accessing the PCMCIA card's data,
  - Do not turn the PS-G unit's power supply OFF,
  - Do not perform remote reset input
  - Do not eject the PCMCIA card (ATA or SRAM cards).Performing any of these actions may damage PCMCIA card data.
- Pro-face recommends you turn the PS-G unit's power OFF prior to inserting/ejecting the PCMCIA card, to protect card data and the PCMCIA unit.
- Wait several seconds between inserting and ejecting the PCMCIA card. Failure to do so may cause the PCMCIA unit to malfunction.

- The PCMCIA unit is compatible with up to PCMCIA Type II EXTEND (PCMCIA Ver. 2.1 compliant) model cards.
- The PCMCIA unit supports 3.3V or 5V cards. It does not support 12V cards.
- If your PCMCIA card uses radio frequencies to transfer data, be sure the antenna is exposed.
- Some commercially available PCMCIA cards cannot be used with the PS-G unit. Contact your local Pro-face representative for a list of supported cards.
- The following PCMCIA card drivers are included with the PS-G unit.

ATA cards:

- ATA interface flash ROM card
- CF Card (CF Card adaptor is required)
- Hard disk card

SRAM card:

- SRAM memory card

Serial I/O card:

- RS-232C card
- Modem card
- Mobile telephone card

- \* *When a CF Card adaptor is used, the CF Card itself will not be supported or protected by the PCMCIA unit's card stopper arm.*
- \* *To use a PCMCIA card other than those described above, the PCMCIA card manufacturer's PCMCIA card driver for the Windows® CE 3.0 SH4CPU is required. For details, please contact your PCMCIA card's manufacturer.*

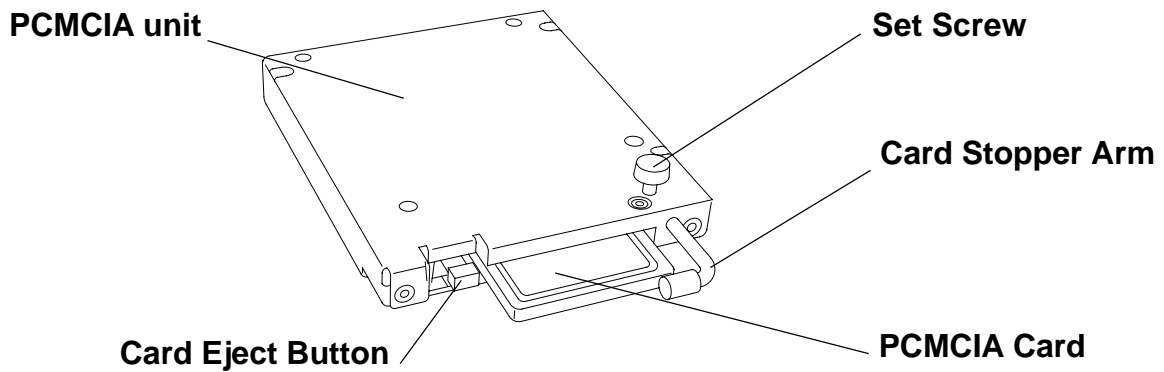

## ■ Installing the PCMCIA Card Unit

- 1) Loosen the Card Stopper Arm set screw, pull the shaft outwards and rotate it so that it does not obstruct the PCMCIA Card slot.
- 2) Confirm that the card is oriented correctly and insert the card completely into the card slot. If the card seems to jam or does not slide into the slot smoothly, recheck the orientation of the card and the card insertion position.
- 3) Adjust the Card Stopper Arm so that the arm contacts the outside face of the card (See above figure).
- 4) Tighten the Card Stopper Arm set screw.

## ■ Removing the PCMCIA Card Unit

- 1) Loosen the Card Stopper Arm set screw, pull the arm outwards, and rotate it until it faces away from the PCMCIA card.
- 2) Press the card eject button, and remove the card. Be careful not to drop the card.



**Note:** *Prior to installing the separately sold rear cover, remove the PCMCIA card, and push the card stopper arm forward.*

### Note

Please be aware that Digital Electronics Corporation shall not be held liable by the user for any damages, losses, or third party claims arising from the uses of this product.

## Digital Electronics Corporation

8-2-52 Nanko Higashi, Suminoe-ku, Osaka 559-0031, Japan

URL: <http://www.pro-face.com/>

© 2001 Digital Electronics Corporation. All rights reserved.

056569E .PSG-PCM00-MT01 2001.12. JM/A