

Factory Gateway

Configuration Tool

Operation Manual

PREFACE

Thank you for purchasing Digital's "Factory Gateway Configuration Tool".

To ensure correct use of this product, be sure to carefully read the manuals included and keep them nearby so that you can refer to them whenever required.

NOTE

- (1) The copyrights to all programs and manuals included in the "Factory Gateway Configuration Tool" (hereinafter referred to as "this product") are reserved by the Digital Electronics Corporation. Digital grants the use of this product to its users as described in the "Software Operating and License Conditions" section. Any actions violating the above-mentioned conditions are prohibited by both Japanese and foreign regulations.
- (2) The contents of this manual have been thoroughly checked. However, if you should find any errors or omissions in this manual, please contact your local representative and inform them of your findings.
- (3) Please be aware that Digital Electronics Corporation shall not be held liable by the user for any damages, losses, or third party claims arising from the uses of this product.
- (4) Differences may occur between the descriptions found in this manual and the actual functioning of this product. The latest information about this product is provided in the accompanying data files (i.e. Readme.txt files, etc.) and/or separate documents. Please consult these sources as well as this manual prior to use.
- (5) Even though the information contained in and displayed by this product may be related to intangible or intellectual properties of the Digital Electronics Corporation or third parties, the Digital Electronics Corporation shall not warrant or grant the use of said properties to any users and/or other third parties.

TRADEMARK RIGHTS

The company names and product names used in this manual are the trade names, trademarks (including registered trademarks), and service marks of their respective companies.

This product omits individual descriptions of each of these rights.

Trademark/Tradename	Right Holder
Microsoft, Windows	Microsoft, U.S.
Intel, Pentium	Intel, U.S.
PC/AT	IBM, U.S.
Pro-face	Digital Electronics Corporation

The following terms used in this manual differ from the above mentioned formal trade names and trademarks.

Term used in this manual	Formal Trade Name or Trademark
Windows 95	Microsoft® Windows® 95 Operating System
Windows 98	Microsoft® Windows® 98 Operating System
Windows Me	Microsoft® Windows® Me Operating System
Windows NT	Microsoft® Windows® NT Operating System
Windows 2000	Microsoft® Windows® 2000 Operating System
Windows XP	Microsoft® Windows® XP Operating System

HOW TO USE THIS MANUAL

Structure of This Manual

This manual, titled “Factory Gateway Configuration Tool Operation Manual” describes how to use the “Factory Gateway Configuration Tool” software.

“Factory Gateway Configuration Tool” is the software running on “Pro-Server with Pro-Studio for Windows”. First of all, we recommend you to carefully read “Pro-Server with Pro-Studio for Windows Operation Manual” and to well understand the features of “Pro-Server with Pro-Studio for Windows”. When you use “GP-Viewer” or “GP-Web” together, be sure to read those related manuals also.

In addition to this manual, be sure to read the readme.txt file since information on supplementary explanations or additional/modified functions may be provided as data files.

TABLE OF CONTENTS

PREFACE	1
NOTE	1
TRADEMARK RIGHTS	2
HOW TO USE THIS MANUAL	3
TABLE OF CONTENTS	4
MANUAL SYMBOLS AND TERMINOLOGY	6
PRECAUTIONS	7
OPERATING ENVIRONMENT	8

Chapter 1 Introduction

1.1 Outline	1-2
1.1.1 What is the 2-Way Function?	1-2
1.2 System Configuration	1-3
1.3 Configuring the System	1-5

Chapter 2 Operations

2.1 Installing the Software	2-2
2.2 Starting the Software	2-5
2.3 Screen Item Names and Functions	2-7
2.4 Configuring the Tool	2-10
2.4.1 IP Address Setup	2-10
2.4.2 Node Information Setup	2-10
2.4.3 Node Information Transfer	2-12
2.4.4 Serial Communication Setup	2-13
2.4.5 Ethernet Communication Setup	2-18
2.4.6 Sending the 2-Way Driver	2-22
2.4.7 Provider Information Setup and Transfer	2-24
2.5 Subnet Mask and Gateway	2-25
2.5.1 Setting Subnet Mask and Gateway for via Router	2-25
2.5.2 Subnet Mask settings in the same Subnet	2-28

Chapter 3 GP-Viewer & GP-Web

3.1 GP-Viewer	3-2
3.1.1 What is GP-Viewer?	3-2
3.1.2 Outline of GP-Viewer	3-2
3.1.3 Configuring the System with GP-Viewer	3-3
3.2 GP-Web	3-4
3.2.1 What is GP-Web?	3-4
3.2.2 Outline of GP-Web	3-4
3.2.3 Configuring the System with GP-Web	3-5

Appendices

A.1	Restrictions	A-2
A.1.1	Restrictions on Factory Gateway Unit	A-2
A.1.2	Restrictions on Pro-Server Features	A-2
A.1.3	Restrictions on Action Item “Contents”	A-3
A.1.4	Restrictions on Factory Gateway Configuration Tool	A-3
A.1.5	Restrictions on GP-PRO/PB III for Windows	A-4
A.1.6	Restrictions on GP-Viewer and GP-Web	A-4
A.2	Error Messages	A-5
A.3	Troubleshooting	A-9





MANUAL SYMBOLS AND TERMINOLOGY

This manual uses the following symbols and terminology.

If you have any questions about the contents of this manual, please contact your local GP distributor. Also, If you have any question about your personal computer or Windows, please contact your local distributor or manufacturer.

Safety Symbols and Terms

This manual uses the following symbols and terms for important information related to the correct and safe operation of this product.

Symbol	Description
 Warning	Incorrect operation resulting from negligence of this instruction may cause death or serious injury.
 Caution	Incorrect operation resulting from negligence of this instruction may cause injury or damage to equipment.
	Indicates Instructions/Procedures that must be performed to ensure correct product use.
	Indicates Actions/Procedures that should not be performed.

General Information Symbols and Terms

This manual uses the following symbols and term for general information.

Symbol	Description
	Provides hints on correct use, or supplementary information.
Reference →	Indicates (manual name, page number) related information.
Pro-Server with Pro-Studio for Windows	Software that allows the Host PC to use the network (Ethernet) to send and receive data from a PLC, via the Factory Gateway.
Screen editor software	Indicates "GP-PRO/PBIII for Windows".
PLC	Acronym for Programmable Logic Controller.
GP/GLC	Generic Name for the "GP Series" of programmable operator interface and "GLC Series" of Graphic Logic Controller made by the Digital Electronics Corporation. GP/GLC series units are a liquid crystal display with touch panel to connect to PLCs and set and display the device data. GLC series units are built in Logic Controller.

PRECAUTIONS

Product Usage Precautions

To prevent program malfunctions or accidents, be sure to observe the following instructions:

Warning

- ❗ Touch panel switches should NOT be used for a device's Emergency Stop switch. Generally speaking, all industrial machinery/systems must be equipped with a mechanical emergency stop switch that can only be operated by people. Also, for other kinds of systems, similar mechanical switches must be provided to ensure safe operation of that system.

Cautions

- ⊘ Do not turn off your personal computer's power switch during the execution of a program.
- Do not change the contents of this product's files using the Text Editor software.

■ CD-ROM Usage Precautions

To prevent CD-ROM damage or malfunctions, please observe the following instructions:

- Do not remove a CD-ROM disk from the CD-ROM drive while the operation lamp is lit.
- Do not touch the CD-ROM recording surface.
- Do not store the CD-ROM disk in a place where it may be exposed to extremely high or low temperatures, high humidity, or dust.

OPERATING ENVIRONMENT

■ Factory Gateway Configuration Tool

“Factory Gateway Configuration Tool” is the plug-in software running on “Pro-Server with Pro-Studio for Windows”. The operating environment is compliant to that of “Pro-Server with Pro-Studio for Windows”.

Item	Specification	Remark
Personal Computer	IBM Compatible	Pentium 133MHz or faster processor
Display	SVGA (800 x 600) or higher	16 bit color or higher
Hard Disk Space Requirements	20 MB or more	30 MB or more is recommended
Memory Requirements	32 MB or more	128 MB or more is recommended
CD-ROM Drive	Windows compatible	
OS Requirements	Windows 95 (English or Japanese)	OSR2 or higher
	Windows 98 (English or Japanese)	
	Windows Me (English or Japanese)	
	Windows NT 4.0 (English or Japanese)	Service Pack 3.0 or higher
	Windows 2000 (English or Japanese)	
	Windows XP (English or Japanese)	
Related software	Browser (IE V4.0 or later)	
Supported languages	Japanese, English	
Mouse	Windows compatible	Mouse is required for operation.
Ethernet Board	10BASE-2/5/T, 100BASE-T	
Network Configuration	TCP/IP Protocol	Set up from Control Panel. *1
Additional Items	Ethernet Hub, Ethernet cables, etc.	User supplied

MEMO

- Depending on the type of Ethernet hub used, Pro-Server may be unable to transmit data. Be sure to test and confirm the compatibility of Pro-Server with your Ethernet network prior to installing a complete Pro-Server with Pro-Studio for Windows system.

*1 Until the TCP/IP protocol is set, Pro-Server with Pro-Studio cannot be used.

■ Software Requirements

- Essential Software

Pro-Server with Pro-Studio for Windows Ver.4.0 or higher

Factory Gateway Configuration Tool

- Software Requirements When Using GP-Viewer

GP-Viewer Ver.1.0 or later

GP-PRO/PB III for Windows Ver.6.0 or later

(GP-PRO/PBIII for Windows Ver.6.0* requires the Factory Gateway unit update module.)

- Software Requirements When Using GP-Web

GP-Web Ver.1.5 or later

GP-PRO/PB III for Windows Ver.6.0 or later

(GP-PRO/PBIII for Windows Ver.6.0* requires the Factory Gateway unit update module.)

■ Factory Gateway compatible PLC Types

The following table lists PLC vendors and types supported by Factory Gateway. *1

Reference → “GP-PRO/PBIII for Windows Device/PLC Connection Manual”

(This is available on our website for downloading.)

Vendor Name	PLC Type
Mitsubishi Electric	MITSUBISHI MELSEC-AnN(LINK)
	MITSUBISHI MELSEC-AnN(CPU)
	MITSUBISHI MELSEC-AnA(LINK)
	MITSUBISHI MELSEC-AnA(CPU)
	MITSUBISHI MELSEC-F2 SERIES
	MITSUBISHI MELSEC-FX(CPU)
	MITSUBISHI MELSEC-FX2(LINK)
	MITSUBISHI MELSEC-QnA(LINK)
	MITSUBISHI MELSEC-QnA(CPU)
	MITSUBISHI MELSEC-Q(CPU)
	MITSUBISHI FREQROL SERIES
Omron	OMRON SYSMAC-C SERIES
	OMRON SYSMAC-CV 1:n Comm.
	OMRON SYSMAC-CV SERIES
	OMRON SYSMAC-CS1 SERIES
OMRON THERMAC NEO SERIES	
Sharp	SHARP NewSatellite JW Series
Yokogawa Electric	YOKOGAWA FACTORY ACE 1:1 Comm.
	YOKOGAWA FACTORY ACE 1:n Comm.
Fuji Electric	FUJI MICRES-F SERIES
	FUJI MICREX-F SERIES (FLT)
	FLEX-PC (LINK)
	FLEX-PC (CPU)
	FUJI INVETER
	FUJI TEMPERATURE PXR
Toyota Machine Works	TOYOTA TOYOPUC-PC2 SERIES
	TOYOTA TOYOPUC-PC2 1:n Comm.
	TOYOTA TOYOPUC-PC3J SERIES
	TOYOTA TOYOPUC-PC3J 1:n Comm.
Yasukawa Electric	YASUKAWA Memocon-SC SERIES
	YASUKAWA GL120/130 SERIES
	YASUKAWA PROGIC8 SERIES
	YASUKAWA GP9200SH SERIES
	YASUKAWA INVERTER
Hitachi	HITACHI HIDIC-S10 SERIES
	HITACHI HIDIC-H SERIES
	HITACHI HIDIC-H2 SERIES
	HITACHI HIZAC-EC SERIES
Toshiba	TOSHIBA PROSEC-EX2000 SERIES
	TOSHIBA PROSEC-T SERIES
Matsushita Electric Works	MATSUSHITA MEWNET-FP SERIES
Koyo Electronics Industries	KOYO KOSTAC-SG8 SERIES
	KOYO KOSTAC SR21/22 SERIES
	KOYO DL-305 SERIES
	KOYO DL-205/405 SERIES

Vendor Name	PLC Type
Toshiba Machine	TOSHIBA TC200 SERIES
	TOSHIBA TC200-S SERIES
GE FANUC Automation	GE FANUC SERIES 90SNP-X
	GE FANUC SERIES 90-30/70SNP
FANUC	FANUC Power Mate SERIES
IDEC Izumi	IZUMI IDEC 1
	IZUMI IDEC 2
	IZUMI IDEC 3
	IZUMI MICRO3
	IZUMI FC3/FC4A SERIES
Siemens AG	SIEMENS S5 90-115 SERIES
	SIEMENS S5 135-155 SERIES
	SIEMENS S5 3964R Protocol
	SIEMENS S7-200PPI
	SIEMENS S7-200MPI
	SIMATIC S7-300/400 via MPI
	SIMATIC S7 via 3964/RK512
	SIMATIC 545/555 CPU
Rockwell (Allen Bradley)	Allen Bradley PLC-5 SERIES
	Allen Bradley SLC500 SERIES
	Allen Bradley Control Logics DF1
Keyence	KEYENCE KV-10/16/24/40 SERIES
	KEYENCE KZ300 SERIES
	KEYENCE KZ-A500 (CPU)
	KEYENCE KZ-A500 (LINK)
	KEYENCE KV SERIES
	KEYENCE KV SERIES (CPU)
Shinko Electric	SHINKO SELMART SERIES
Matsushita Electric Industrial	MINAS-A/S SERIES
	Panadac 7000 SERIES
Modicon Corp.	Modicon Modbus(MASTER)
	Modicon Modbus(SLAVE)
FACON	FATEK FACON FB
ORIM VEXTA	ORIM VEXTA E1 SERIES
Yamatake	YAMATAKE SDC SERIES
Toho Electronics	TOHO TTM SERIES
RKC INSTRUMENT	RKC CB/SR-Mini(MODBUS)
	RKC CB/REX-F/LE100(RKC)
Shinko Technos	SHINKO TECHNOS INDICATING
Fenwal	Fenwal AL series
JT Engineering	JTE Analyzer
SHIMADEN Co.,Ltd.	SHIMADEN CONTROLLER
Other Device	Memory Link SIO Type

*1 It is different from PLC types supported by GP/GLC in Pro-Server with Pro-Studio for Windows. Ethernet protocol (Supports particular Ethernet protocol.) or protocol which requires a communication extension unit is not supported.

Reference → “Ethernet protocol supported by Factory Gateway”, “Protocol supported by Factory Gateway and requires a setup on GP-PRO/PB III” (page 12)

■ Ethernet protocol supported by Factory Gateway

The following list shows Ethernet protocol supported by Factory Gateway.

Vendor	Ethernet Protocol Name
Other	Memory Link Ethernet Type Protocol
Mitsubishi Electric	Mitsubishi MELSEC-A (Ethernet) Protocol
	Mitsubishi MELSEC-Q (Ethernet) Protocol
Yokogawa Electric	Yokogawa Electric FA-M3 (Ethernet) Protocol
Toshiba	Toshiba PROSEC-T (Ethernet) Protocol
Meidensha	Meidensha RC100 (Ethernet) Protocol

■ Protocol supported by Factory Gateway and requires a setup on GP-PRO/PB III

Vendor	Protocol Name
Omron	OMRON SYSMAC-CS1(Ethernet) protocol
Hitachi	HITACHI HIDIC-H(ETHER) protocol
Siemens AG	Siemens S7-300/400 via MPI (When accessing extended addresses or multiple PLC units.)
	Siemens S7-200 MPI
Rockwell (Allen Bradley)	Allen Bradley SLC500 DH485
	Allen Bradley SLC5/05(ETHER)

1

Introduction

This chapter describes the overview of Pro-Server, the roles of Factory Gateway, and how to build the system to sample data from equipments.

- 1.1 Outline
- 1.2 System Configuration
- 1.3 Configuring the System

1.1 Outline

Factory Gateway Configuration Tool is the plug-in software running on Pro-Server with Pro-Studio for Windows, and it establishes and transfers the driver used for communications between Factory Gateway and external equipments such as PLCs.

Factory Gateway is the driver converter that connects external equipments such as PLCs connected to Factory Gateway to Ethernet and enables data samplings from the host personal computer (PC). External equipments connected to Pro-Server can share data with other external equipments without programs (2-Way Function).

You can also view PLC data graphically on the host PC or remote PCs if you use the Pro-Server's plug-in software such as GP-Viewer or GP-Web.

1.1.1 What is the 2-Way Function?

The 2-Way system is to directly access to external equipments data such as PLCs connected to Factory Gateway via a network (Ethernet) from the host PC. The advantage of this system is that you can exchange data with the host PC without considering of differences of communication procedures among various external equipments such as PLCs.

To use the 2-Way function, Pro-Server as the server and Factory Gateway, GP or GLC to relay data with external equipments such as PLCs are required.

Reference → "1.2 System Configuration"

1.2 System Configuration

The following figure describes the system configuration using Factory Gateway.

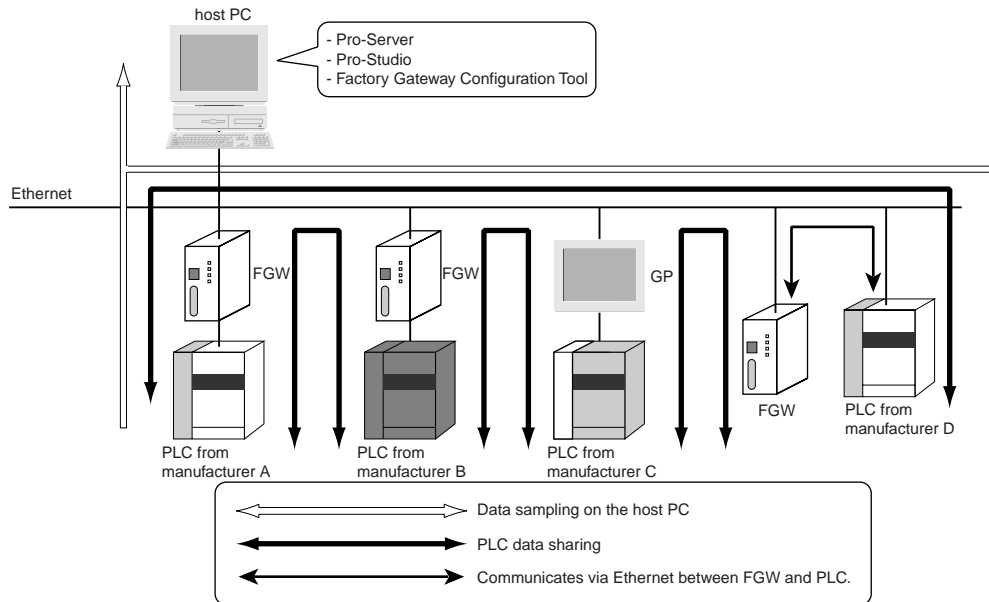

Serial/Ethernet communications are carried out between Factory Gateway and PLCs, and Factory Gateway communicates with the host PC via Ethernet. In the case of Pro-Server system, Factory Gateway allows you to sample data without considering of driver differences among manufacturers (white arrow) and to share data (black arrow) by connecting the host PC with PLCs.

- Memory Link Ethernet Type Protocol
- Mitsubishi MELSEC-A (Ethernet) Protocol
- Mitsubishi MELSEC-Q (Ethernet) Protocol
- Yokogawa Electric FA-M3 (Ethernet) Protocol
- Toshiba PROSEC-T (Ethernet) Protocol
- Meidensha RC100 (Ethernet) Protocol
- Omron SYSMAC-CS1 (Ethernet) Protocol (Must be set up using GP-PRO/PBIII.)
- Hitachi HIDIC-H (ETHER) Protocol (Must be set up using GP-PRO/PBIII.)
- Rockwell Allen Bradley SLC5/05 (ETHER) Protocol (Must be set up using GP-PRO/PBIII.)

MEMO

It also allows you to share data of PLCs connected to GPs or GLCs.

■ Pro-Server

The software running on the host PC. It translates the information of each PLC and the applications. It transfers sampled data to application software on the host PC, or also transfers data sampling commands from those application software to Factory Gateway.

■ Pro-Studio

It establishes entry nodes (Factory Gateway or GP) to the Pro-Server system, and sets a data sampling (providing setup). Setup information is saved in a network project file (*.npj). You will be able to execute the contents in the provider setup by transferring the saved network project to Factory Gateway or to GPs. You will also use it as the tool to set the subnet mask and the default gateway of Factory Gateway.

■ Factory Gateway Configuration Tool

The tool to set serial/ethernet communications between Factory Gateway and PLCs. You will also use it as the tool to transfer drivers and the setup contents to Factory Gateway.

1.3 Configuring the System

The following figure describes the steps to build the Pro-Server system using Factory Gateway.

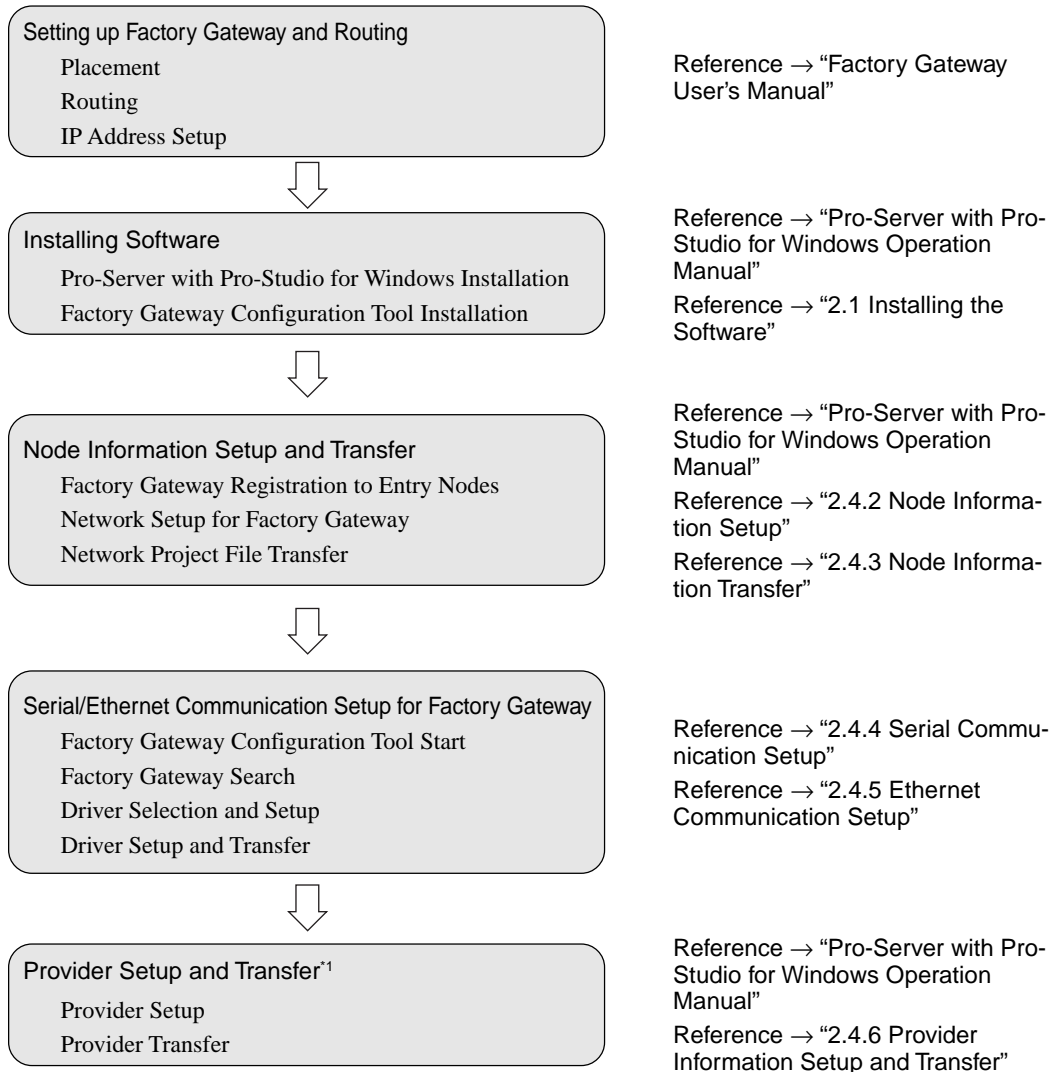

MEMO

In the case that you use GP-Web or GP-Viewer, you need to install, draw and transfer the software separately.

Reference → “Chapter 3 GP-Viewer & GP-Web”

This manual describes how to operate Factory Gateway Configuration Tool. You should refer to corresponding manuals about hardware setups or Pro-Server with Pro-Studio for Windows operations.

Reference → “Factory Gateway User’s Manual”

Reference → “Pro-Server with Pro-Studio for Windows Operation Manual”

*1 When using a provider, this step must be done.

2 | Operations

This chapter describes how to install this software. It also explains the procedures for starting and exiting the software.

- 2.1 Installing the Software
- 2.2 Starting the Software
- 2.3 Screen Item Names and Functions
- 2.4 Configuring the Tool
- 2.5 Subnet Mask and Gateway

2.1 Installing the Software

This section describes how to install Factory Gateway Configuration Tool from the CD-ROM to your hard disk. The following explanation assumes that Windows and Pro-Server with Pro-Studio for Windows Ver.4.0 or higher have already been installed on your PC.

For the Pro-Server with Pro-Studio for Windows installation:

Reference → “Pro-Server with Pro-Studio for Windows Operation Manual”

MEMO

- Before starting the installation procedure, exit all programs except the Factory Gateway Configuration Tool Setup program. You also need to terminate memory-resident programs (such as Virus detection software) as well as other application programs.
 - Copying the files on the master CD-ROM and pasting them onto your hard disk does not install this software. To be able to start this software, you must use the Setup program.
1. Insert the CD-ROM into your PC's CD-ROM drive.
 2. Click the [Start] button and, when the Start menu appears, select [Run].

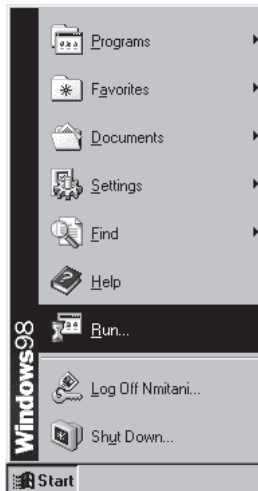

3. Type “X:/2Wsetup.exe” and then click [OK]. (“X” represents the drive letter assigned to your CD-ROM drive.)

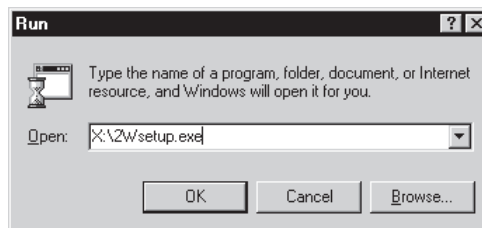

The master CD-ROM supports the AutoPlay feature, which means inserting it into your CD-ROM drive will automatically start the Setup program.

- The installation menu appears. Click the "FGW Config Setup" bar.

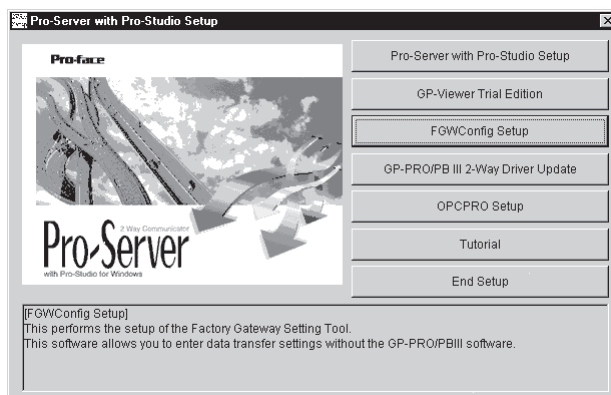

- Select which language you wish to use in the Setup program (English or Japanese) and click "OK".



- [Installed Shield Wizard] dialog will start.

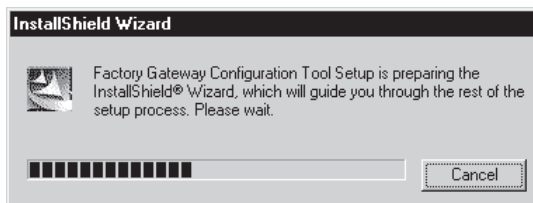

7. [Factory Gateway Configuration Tool Setup] wizard will start. Click on the [Next] button.

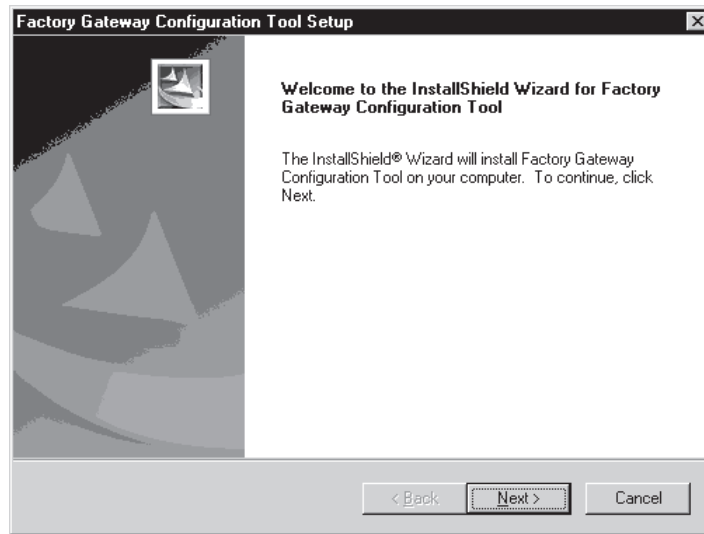

8. [Question] window is shown. When GP-PRO/PBIII for Windows has been installed on your PC, select [Yes]. If not, select [No].

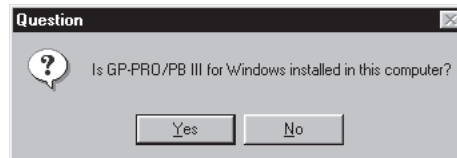

MEMO

- When selecting [Yes], the driver is not installed. Factory Gateway Configuration Tool uses the GP-PRO/PBIII for Windows driver. When installing GP-PRO/PBIII for windows as “Custom” and selecting a driver you want to use, certain drivers are not shown on Factory Gateway Configuration Tool.
- When selecting [No], install new drivers to Pro-Server with Pro-Studio for Windows folder.

After this, follow the instructions displayed on the screen.

If you use Ethernet protocol under the environment of GP-PRO/PB III for Windows C-Package02 or older, select “GP-PRO/PB III 2-Way Driver Update” (refer to “Installation Menu” in the previous page) and update it to protocol supported by Factory Gateway.

When updating GP-PRO/PBIII for Windows C-Package01, be sure to download both the [GP-PRO/PBIII Driver Update] and the [GP-PRO/PBIII Update Module] from Pro-face’s homepage.

2.2 Starting the Software

This section describes how to start this software.

Starting Factory Gateway Configuration Tool

The following explanation assumes that the Windows desktop is already displayed.

1. Click on the [Start] button and when the Start menu appears, point to [Programs], [Pro-face] and [Pro-Server with Studio] and then select [Pro-Studio].

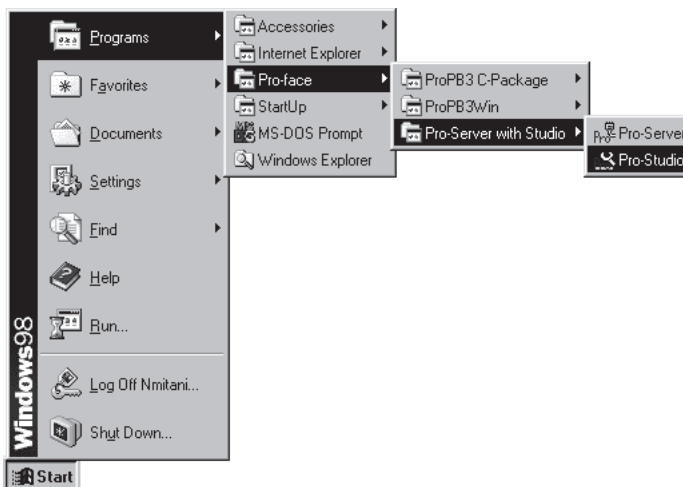

2. The program's main window will appear.

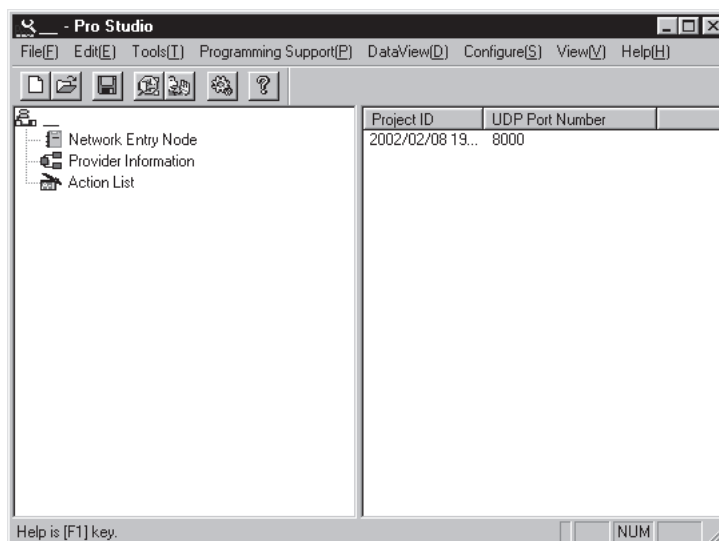

MEMO

Starting Pro-Studio automatically starts Pro-Server. Pro-Server resides in memory and its indicator appears on the right side of the task-tray.

3. Click [Setup Factory Gateway] in [Tools (T)] of the menu bar.

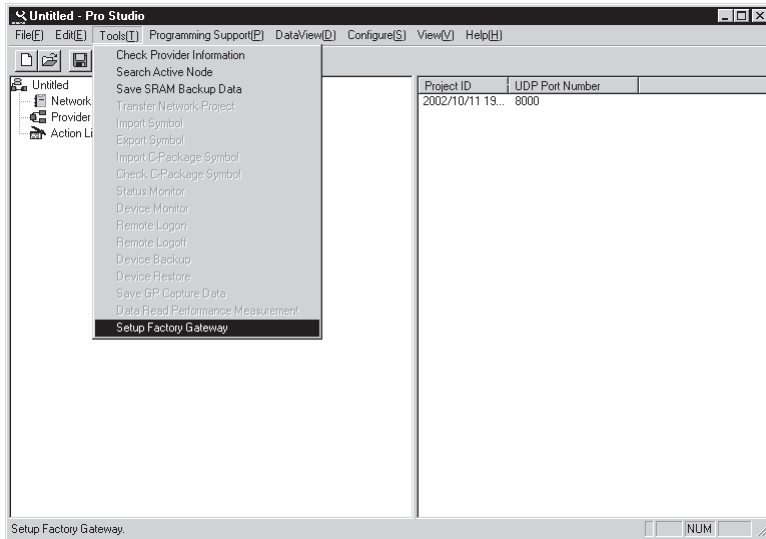

4. [Factory Gateway Configuration Tool] starts.

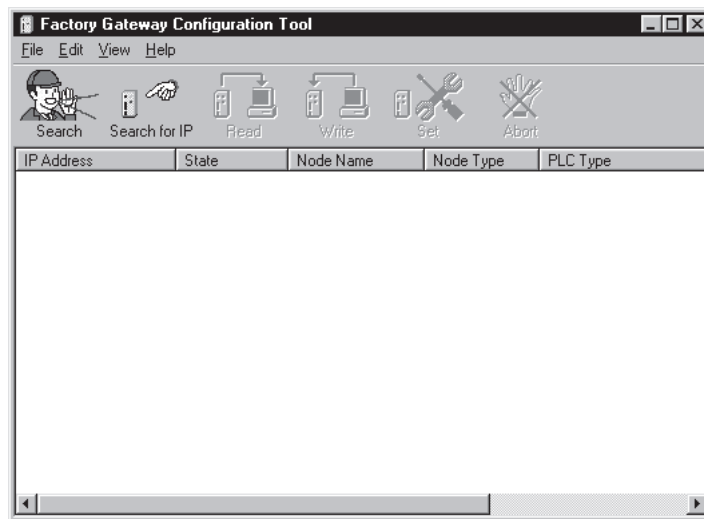

2.3 Screen Item Names and Functions

This section describes the names and functions in the Factory Gateway Configuration Tool's main screen.

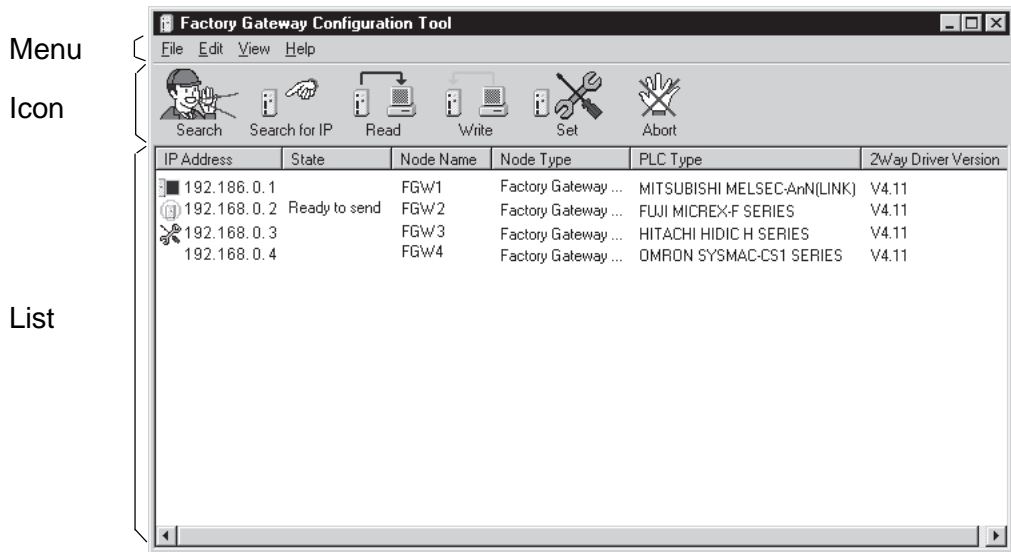

[Icon]



Search Searches Factory Gateway on the network.



Search for IP Designates and searches IP addresses of Factory Gateway.



Read Reads the setup information of the selected Factory Gateway driver.



Write Writes the setup information of the selected Factory Gateway driver.



Set Opens the window to set the selected Factory Gateway driver.







Abort Aborts a search / read / write process.

[List]

The searched Factory Gateway information is listed here. The list also includes GPs, GLCs or the PC where Pro-Server is running as well as Factory Gateway, however, only Factory Gateway Configuration Tool can change, set and transfer a driver of Factory Gateway.

IP Address The searched IP addresses of Factory Gateways are listed. On the left sides of those IP addresses, “Status Icons” showing their states appear.

Icon	State
(blank)	Completed a search process only.
	Reading driver setup information.
	Completed a driver and setup information read.
	Completed a driver and a setup information setting (change).
	Writing (changing) a driver and setup information.
	Completed a driver and a setup information write (change).

State Factory Gateway states are listed.

State	Description
(blank)	Not yet operated.
Waiting to search	Waiting for a node information read.
Now searching	Reading node information.
Waiting for data readout	Waiting for setup information read of a driver.
Now performing data readout	Reading driver setup information.
Waiting for data write	Waiting for a driver and a setup information write.
Now performing data write	Writing a driver and setup information.
Now entering settings	Setting a driver.
Ready to send	Completed a setup change (no write processes are executed).
(Error)	An error occurred during searching, reading, writing or setting. Reference → “A.2 Error Messages”

Node Name Node names set to Factory Gateway are listed.

Node Type Types of Factory Gateway are list.

PLC Type Drivers set to Factory Gateway are listed.

2Way Driver Version

Displays the Factory Gateway’s current 2-Way Driver version number.

[Menu]**File(F)**

- Open(O) Opens the saved Configuration file (*.fgw).
- Save(S) Overwrites the setup contents on the Configuration file (*.fgw)
- Save As(A) Saves the setup contents as a separate Configuration file (*.fgw).
- Exit(X) Exits Factory Gateway Configuration Tool.

Edit(E)

- Search(S) Searches Factory Gateway on the network.
- Search for IP(I) Designates and searches IP addresses of Factory Gateway.
- Read(R) Reads the setup information of the selected Factory Gateway driver.
- Write(W) Writes the setup information of the selected Factory Gateway driver.
- Abort Aborts a search / read / write process.

View(V)

- Tool Bar(T) Toggles the tool bar (icon) display.

Help(H)

- Help(H) Displays the online help.
- About(A) Displays the version information of Factory Gateway Configuration Tool.

2.4 Configuring the Tool

The following instruction explains how to set transferring a driver to Factory Gateway.

2.4.1 IP Address Setup

The IP address setup can be done using the rotary switch on the right side of the Factory Gateway unit. Reference → “Factory Gateway User’s Manual” (optional)

After setting the IP address, connect Factory Gateway to Ethernet and turn the power on.

2.4.2 Node Information Setup

The Ethernet setting that you can do with the Factory Gateway unit is only an IP address. You should set “Subnet Mask” or “Gateway” using Pro-Studio if necessary. You should setup Factory Gateway’s “node names” on Pro-Server also using Pro-Studio.

The following describes operations after the [Pro-Studio] main screen is displayed.

1. Click [Register Node] in [Edit(E)] of the menu bar.

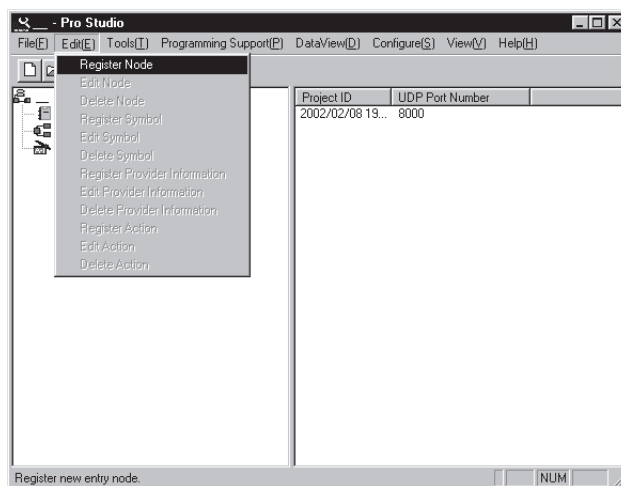

2. The [Register Node] dialog appears.

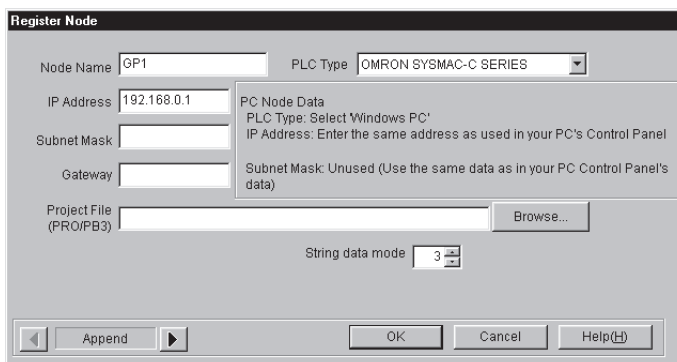

3. Change "Node Name". It is defaulted to "GP*:". In the case of Factory Gateway, it is recommended to set it such as "FGW*_PLCName".

Select an equipment to connect to Factory Gateway as "PLC Type".

Set "Subnet Mask" or "Gateway" if necessary.

Reference → "2.5 Subnet Mask and Gateway"

MEMO

- "Project File" is designated when using the symbol setting in GP-PRO/PBIII for Windows. When you do not use a symbol, this setting is not required. If the "Project File" has been designated, the node name will be automatically changed to GP-PRO/PB III for Windows's project file name (*.prw).
 - "String data mode" is to select the storage order of PLC's string data. The mode will be selected automatically depending on "PLC Type", and you do not have to change it unless you need to.
 - Putting a sticker written IP Address and Node No. on Factory Gateway is recommended. It is very useful to distinguish devices during maintenance.
4. Confirm your registration by clicking [OK].
 5. If there are more than one Factory Gateway to connect, repeat procedure 1 through 4 as many times as the number of FGWs.

2.4.3 Node Information Transfer

This section describes the transfer of configured node information to Factory Gateway. Configured node information transferred here is set to Factory Gateway.

1. Save the file as a network project file, and select Factory Gateway to which you transfer the file.

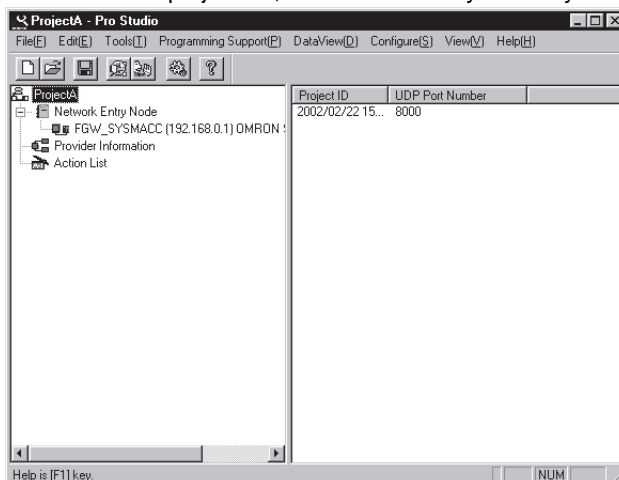

2. Click [Transfer Network Project] in [Tools(T)] of the menu bar.

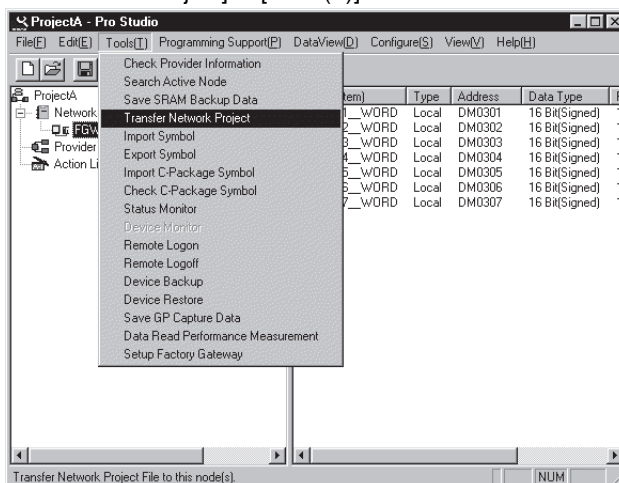

3. The [Transfer Network Project] dialog appears, and the progress status is displayed.

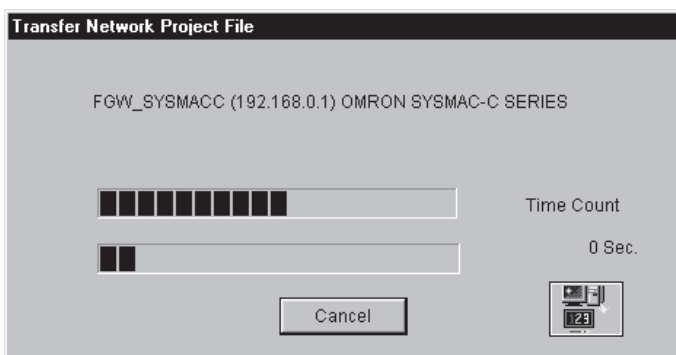

4. If there are more than one Factory Gateway to connect, repeat procedure 1 through 3 as many times as the number of Factory Gateways.

2.4.4 Serial Communication Setup

You must setup serial communication if you connected Factory Gateway and PLC in serial.

Transferring a network project file to Factory Gateway does not mean transferring a driver. You should transfer a driver using Factory Gateway Configuration Tool.

You must setup Ethernet communication if you connected Factory Gateway and PLC via Ethernet.

Reference → “2.4.5 Ethernet Communication Setup”

The following describes operations after you transferred a network project file to Factory Gateway.

1. Click [Setup Factory Gateway] in [Tools(T)] of the menu bar.

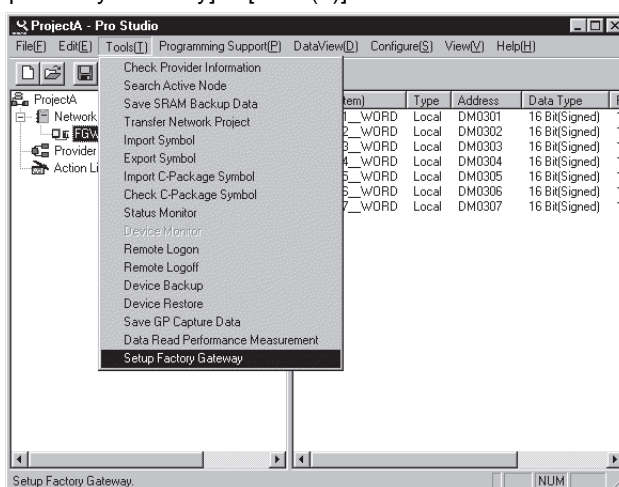

2. [Factory Gateway Configuration Tool] starts.

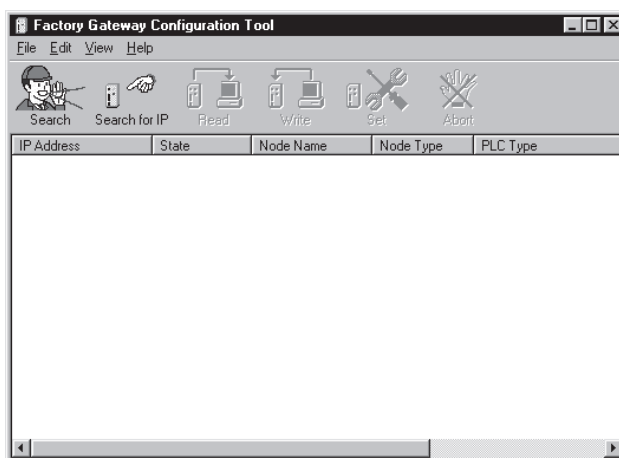

3. Click the  [Search] icon.

4. The searched Factory Gateways are displayed in the [List] field.

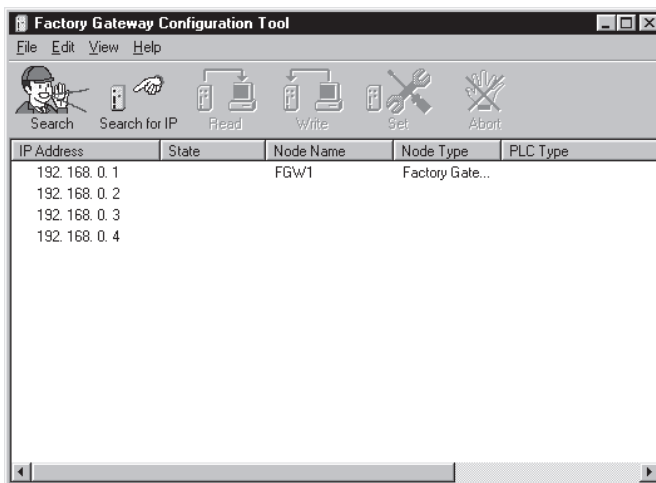
**MEMO**

- Factory Gateway Configuration Tool displays GPs, GLCs and PCs that Pro-Servr is operating. Only Factory Gateway's driver can be set, changed and transferred.
- If no drivers have not been transferred to Factory Gateway, the [PLC Type] field is left blank.
- When searching for the Factory Gateway, the Factory Gateway's subnet mask data and the Pro-Server PC's subnet mask data must be the same.

5. Select Factory Gateway to which you transfer a driver.

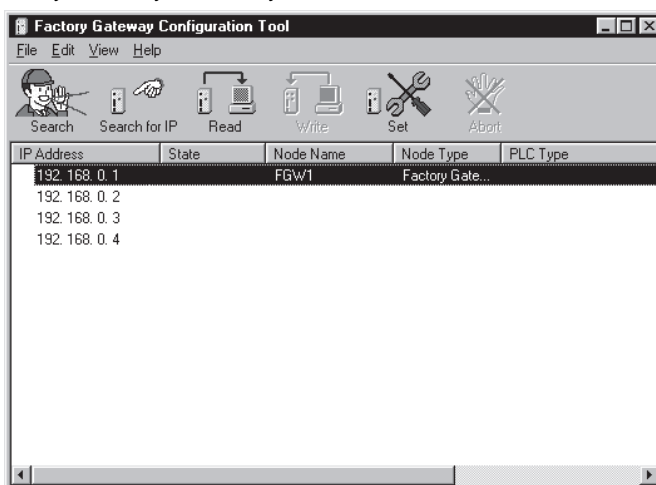
**MEMO**

If you select more than one Factory Gateway and perform the procedure from 6, you can set all Factory Gateways selected to the same contents.

6. Click the  [Set] icon.

After reading driver setup information, the setup window will appear.

MEMO

If you have already clicked the  [Read] icon and read driver setup information, the setup window will appear without a reading process.

7. The driver setup window appears.

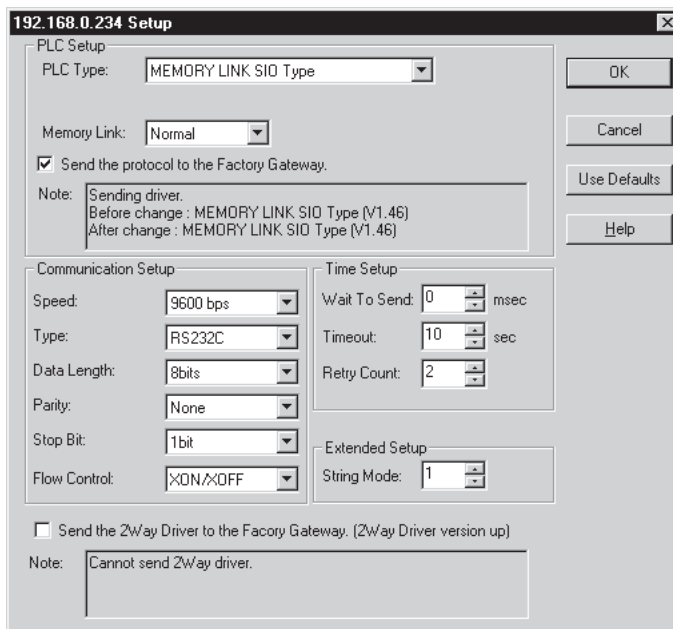
**MEMO**

If no drivers have not been transferred to Factory Gateway, [MEMORY LINK SIO Type] is selected.

8. Select PLC to connect to Factory Gateway from “PLC Type”.
 (“MITSUBISHI MELSEC-AnN(LINK)” has been selected in this example.)

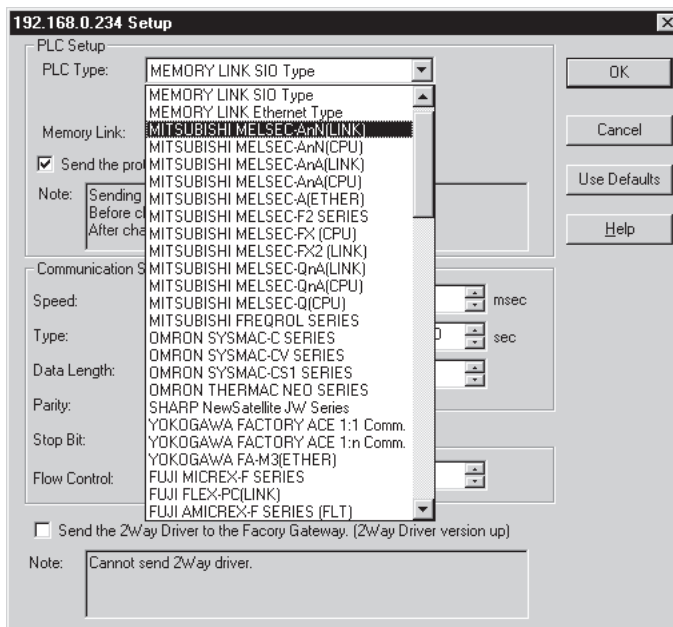

9. If you change “PLC Type”, all setups are reset to initial values.
Confirm “PLC Type”, and then click “Yes”.

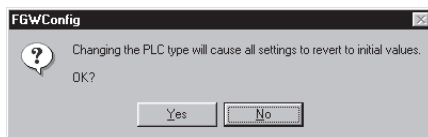

10. The setup windows corresponding to selected “PLC Type” appears.

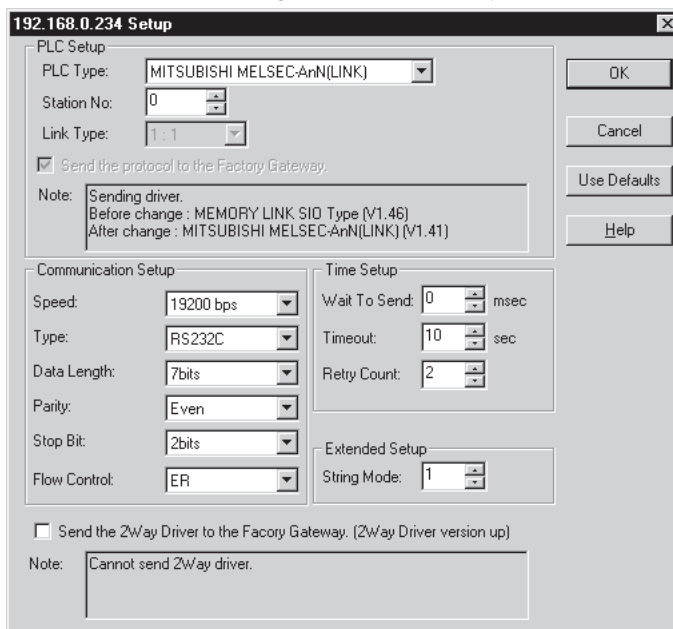

11. Set each fields according to the PLC to be connected.

After you complete the setup, click the [OK] button.

MEMO

- Refer to the online help for the explanation of each setup item within the setup window. If you click the [Help] button, the online help corresponding to selected “PLC Type” is displayed.
- You can send the 2-Way Driver from the [Protocol Setup] screen. For details, refer to 2.4.6 Sending the 2-Way Driver.

12. You are asked if you wish to transfer the driver set to Factory Gateway. If you wish to do it, click [Yes].

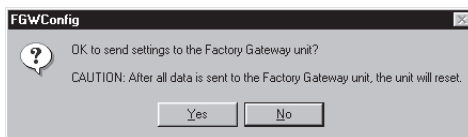

When “Writing ...” disappears and the “Status Icon” changes to , the write process is completed.

MEMO

- Factory Gateway interrupts a communication with PLC while transferring a driver. When a driver transfer is completed, Factory Gateway is reset and restarts a communication with PLC.
- If you click [No], the setup is saved but it will not be transferred to Factory Gateway. If you wish to transfer the setup contents later, click the  [Write] icon.

13. If there are more than one Factory Gateway to connect, repeat Step 5 through 12 as many times as the number of Factory Gateways.
14. When you transferred drivers to all Factory Gateways, the setup procedure completes. Click [Exit(X)] in [File(F)] of the menu bar to exit Factory Gateway Configuration Tool.

MEMO

If you wish to save the setup contents, click [Save(S)] in [File(F)]. The contents to be saved are searched node information and the driver setup contents.

2.4.5 Ethernet Communication Setup

You must setup Ethernet communication if you have connected a Factory Gateway to a PLC via an Ethernet network.

The setup procedure is basically same as “2.4.4 Serial Communication Setup”.

The explanation here will focus on Ethernet settings.

1. Perform steps 1 through 4 in “2.4.4 Serial Communication Setup”.
2. Select the Factory Gateway unit which will transfer the protocol. Here, you can select only one Factory Gateway unit.

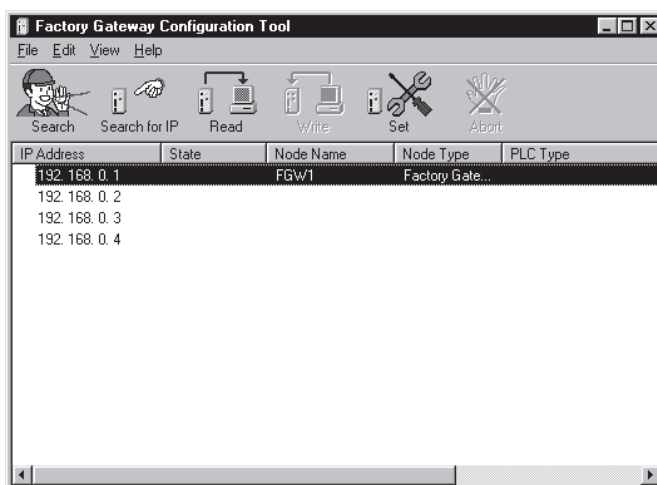

3. Perform steps 6 and 7 in “2.4.4 Serial Communication Setup”.

- Select the PLC that is connected to the Factory Gateway unit from the “PLC Type” pull-down list.

The following six types of protocols support Ethernet communication via a Factory Gateway unit.

- Memory Link Ethernet Type (when using protocol “V1.65” or later)
- Mitsubishi MELSEC-A (Ethernet) Protocol (when using protocol “V1.65” or later)
- Mitsubishi MELSEC-Q (Ethernet) Protocol (when using protocol “V1.63” or later)
- Yokogawa Electric FA-M3 (Ethernet) Protocol (when using protocol “V1.65” or later)
- Toshiba PROSEC-T (Ethernet) Protocol (when using protocol “V1.64” or later)
- Meidensha RC100 (Ethernet) Protocol (when using protocol “V1.61” or later)

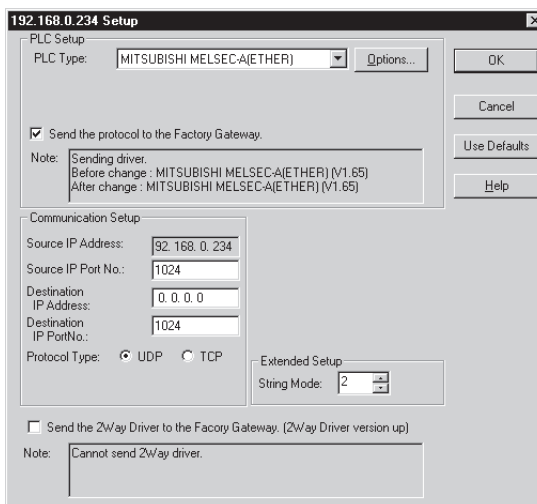

Even though the “OMRON SYSMAC-CS1 (Ethernet)”, “Hitachi HIDIC-H(ETHER)” and “Rockwell Allen Bradley SLC5/05(ETHER)” protocols are supported by the Factory Gateway, you cannot set them up from the Factory Gateway configuration tool. To set up any of these protocols use GP-PRO/PB III for Windows. Be sure to confirm that the protocol version is “V1.65” or later.

MEMO

If a protocol has never been transferred to the Factory Gateway unit, the “Memory Link SIO Type” is selected.

- If you change the Factory Gateway unit's “PLC Type”, all Factory Gateway unit settings will be reset to their initial values.

After checking that you have selected the correct “PLC Type”, click [OK].

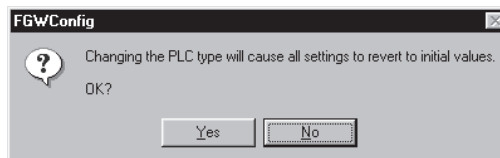

6. The setup screen for the selected “PLC Type” (protocol) will appear. Enter all desired settings, and click [OK].

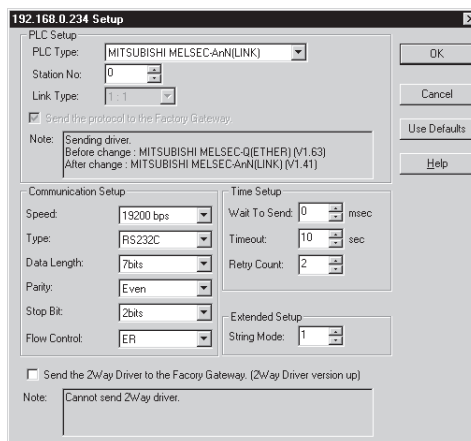

The setting items available for each “PLC Type” (items displayed on the setup screen) are shown in the table below.

PLC Type	Communication Setup						Extended Setup
	Source IP Address	Source IP Port No.	Destination IP Address	Destination IP Port No.	Communication Method	Data Code Setup	String Mode
Memory Link Ethernet Type	Preset by user	O	X	X	X	X	O
Mitsubishi MELSEC-A (Ethernet) Protocol	Preset by user	O	O	O	O	X	O
Mitsubishi MELSEC-Q (Ethernet) Protocol	Preset by user	O	O	O	O	O	O
Yokogawa Electric FA-M3 (Ethernet) Protocol	Preset by user	O	O	O	O	O	O
Toshiba PROSEC-T (Ethernet) Protocol	Preset by user	O	O	O	X	X	O
MEIDEN RC100 (Ethernet) Protocol	Preset by user	O	O	X	X	X	O

O Setup required

X No setup required

Preset by user .. Fixed

[Communication Setup]

Source IP Address Displays the previously set IP address of the Factory Gateway (selected in step 2).

Source IP Port No. Sets the Factory Gateway port number. The setup range is 1024 to 65535.

Destination IP Address.. Sets the IP address of the PLC connected to the Factory Gateway.

Destination Port No. Sets the port number of the PLC connected to the Factory Gateway. The setup range is 1024 to 65535.

Protocol Type Select the communication method, either “TCP” or “UDP”.

Data Code Setup Select the data code, either “Binary” or “ASCII”.

[Extended Setup]

String Mode String Mode is used to set the storage order of PLC character string data. The setup range is 1 to 8. Normally, this is left unchanged since it is automatically set according to the PLC.

[Send the 2Way Driver to the Factory Gateway. (2Way Driver version up)]

Select this option when updating the 2-Way Driver. Also, be sure that the Factory Gateway unit's Dip Switch 6 is ON.

Note Both 2-Way Driver versions (before and after the update) will be displayed.

Also, if you click [Options...], the following dialog box will appear.

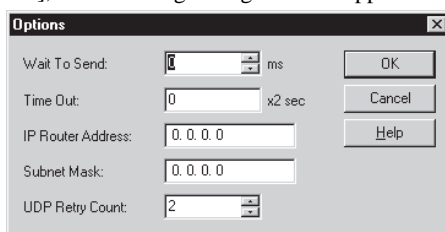

Wait To Send Commands are sent by the Factory Gateway after the designated interval.

Time Out If there is no response from the PLC within the time designated here, it will be regarded as a time-out and the connection will be terminated.

IP Router Address Sets the IP address of the router.

Subnet Mask Sets the subnet mask.

UDP Retry Count Set the UDP communication retry count. This setting is enabled only if you selected "Mitsubishi Electric MELSEC-A (Ethernet)", "Mitsubishi Electric MELSEC-Q (Ethernet)" or "Yokogawa Electric FA-M3 (Ethernet)" for "PLC Type".

7. Perform steps 12 through 14 in "2.4.4 Serial Communication Setup".

2.4.6 Sending the 2-Way Driver

When the Factory Gateway unit is set up, the 2-Way Driver can be updated.

Check the “Send the 2Way Driver to the Factory Gateway. [2Way Driver version up]” option within the [Factory Gateway Configuration Tool | Protocol Setup] dialog box. Also, be sure to turn ON the Factory Gateway unit’s Dip Switch 6.

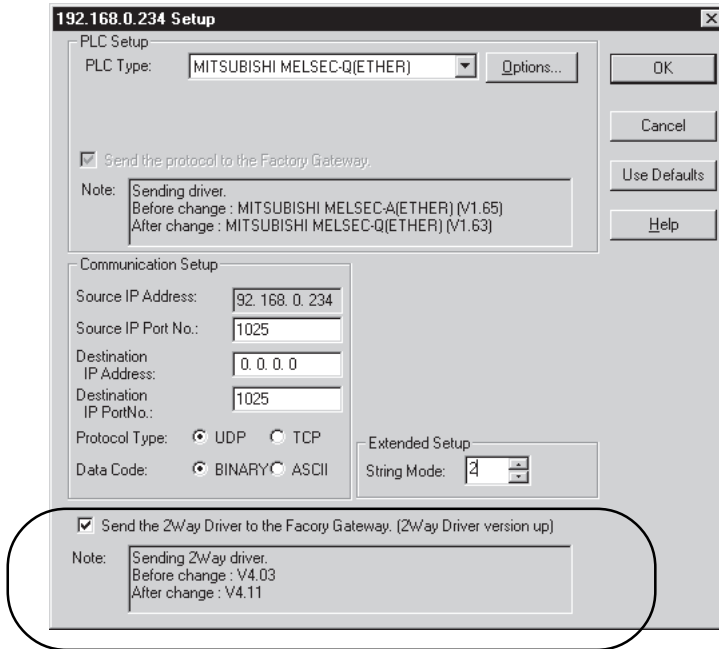

When the “Send the 2Way Driver to the Factory Gateway. [2Way Driver version up]” option is checked within the [Communication Setup] dialog box, the following dialog box is displayed:

- When this option is checked and [OK] is clicked,

The “2-Way Driver send” confirmation dialog box appears. When sending the 2-Way Driver to multiple Factory Gateway units, only the time data for when the 2-Way Driver was sent to the first Factory Gateway unit is displayed.

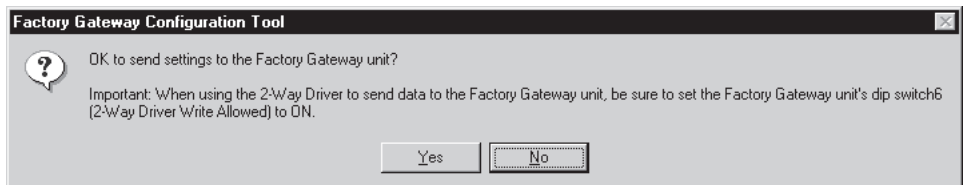

- Sending an older version 2-Way Driver

When sending an older version 2-Way Driver, a confirmation dialog box appears. To send the older version, click [Yes].

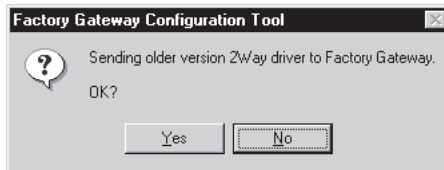

The 2-Way Driver's version can be confirmed via the time stamp on the [protocol] folder's Tw_2000.ex3 file. E.g., 2-Way Driver Ver 4.11 will have the time stamp 4:11.

The [protocol] folder can be found in the **GP-PRO/PBIII for Windows** or **Pro-Server with Pro-Studio for Windows** installation folder.

- After sending the 2-Way Driver and updating the Factory Gateway unit's 2-Way Driver version

When the 2-Way Driver is updated, a confirmation dialog box appears. Set Dip Switch 6 to OFF and restart the Factory Gateway unit.

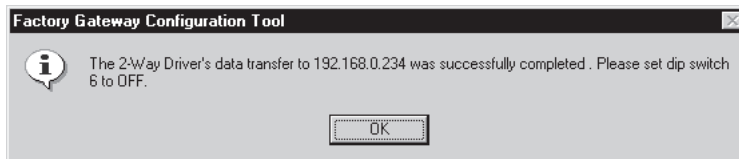

- The 2-Way Driver was sent, but the Factory Gateway unit's 2-Way Driver's version was not updated

When the 2-Way Driver is not updated, a confirmation dialog box appears. Confirm that the Factory Gateway unit's Dip Switch 6 is set to ON, and resend the 2-Way Driver.

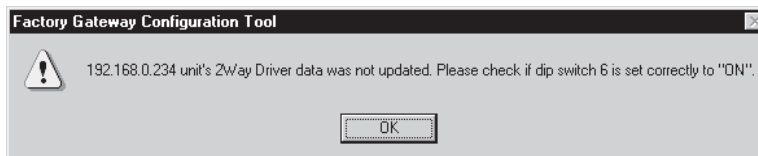

2.4.7 Provider Information Setup and Transfer

This section describes the setup to share data with other PLCs. In the Pro-Server environment, sending of a device connecting to a Factory Gateway to the other device connecting to a Factory Gateway is called as “Provider”. The specific providing can also be done in cooperation with other application software. This is called as “Action”.

To setup “Provider”, you need to register the device address as “Symbol” (alias) and to also register “Provider Information”. In the case of “Action”, you should setup “Action” and register the start timing of “Action” as “Provider Information”.

Configured provider information is saved in a Network Project. Transferring the network project form Pro-Studio to Factory Gateway enables registered provider information to be executed.

For details about the setup and transfer:

Reference → “3.3 Registering Provider Data” and “Chapter 5 GP Setup” in “Pro-Sever with Pro-Studio for Windows Operation Manual”

2.5 Subnet Mask and Gateway

Although it has a rotary switch to setup the IP address of the Factory Gateway unit, there are no switches for setting the subnet mask or the default gateway.

You can setup the subnet mask and the default gateway of Factory Gateway by transferring a network project file using Pro-Studio.

MEMO

The explanation here assumes that you understand the basis of LAN such as the network terminology (e.g. "Subnet Mask" or "Default Gateway") or the Windows TCP/IP setup.

2.5.1 Setting Subnet Mask and Gateway for via Router

You need to setup the subnet mask and the default gateway to let the Pro-Server PC on a different subnet communicate with Factory Gateway.

This section describes how to setup the subnet mask and the default gateway when the Pro-Server PC and Factory Gateway belong to different subnets.

This example is to set the network configuration of the Pro-Server PC and of Factory Gateway as the following.

Pro-Server PC's TCP/IP settings

IP Address	: 192.168.10.10
Subnet Mask	: 255.255.255.0
Default Gateway	: 192.168.10.1

Factory Gateway's Network Project file settings

IP Address	: 192.168.5.5
Subnet Mask	: 255.255.255.0
Default Gateway	: 192.168.5.1

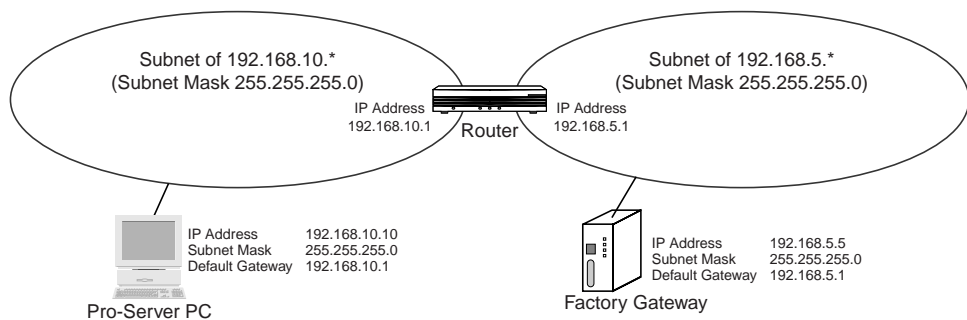

1. Set the network configuration of the Pro-Server PC as the following.

Pro-Server PC's TCP/IP settings

IP Address : 192.168.5.6

Subnet Mask : 255.255.255.0

2. Set the IP address of Factory Gateway as the following using the rotary switch on the unit.

Factory Gateway's Network Project file settings

IP Address : 192.168.5.5

B:If not set the subnet mask, Factory Gateway will understand it as the same class as IP address's set with rotary switches. Therefore, the settings will be as follows;

Subnet Mask : 255.255.255.0

3. Connect the Pro-Server PC to the same subnet LAN as the Factory Gateway.

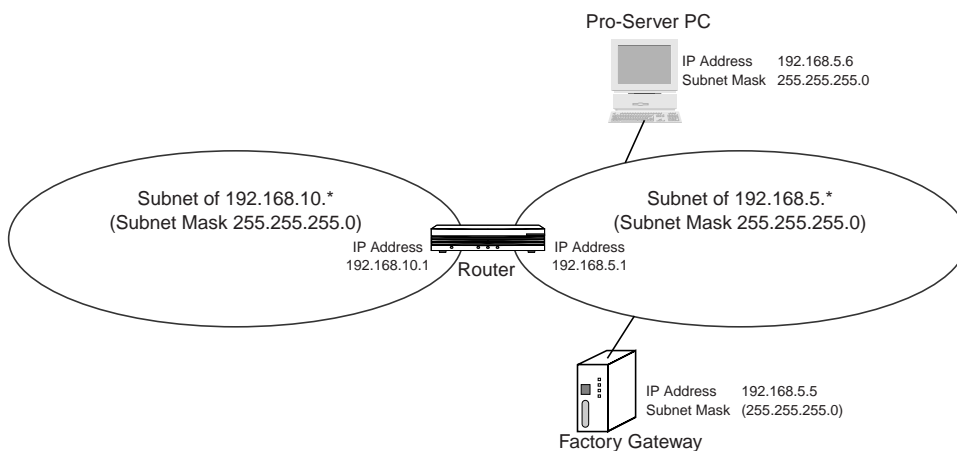

4. Register the entry node (Factory Gateway) using Pro-Studio on the Pro-Server PC.

The setup contents are as the following.

Node Name : optional node name

PLC Type : PLC to be connected to Factory Gateway

IP Address : 192.168.5.5

Subnet Mask : 255.255.255.0

Default Gateway : 192.168.5.1

Other Settings : no changes

The screenshot shows the 'Register Node' dialog box. The fields are filled as follows: Node Name: FGW1, PLC Type: MEMORY LINK SIO Type, IP Address: 192.168.5.5, Subnet Mask: 255.255.255.0, Gateway: 192.168.5.1. The Project File (PRO/PB3) field is empty with a 'Browse...' button. The String data mode is set to 1. The dialog has 'Append', 'OK', 'Cancel', and 'Help(H)' buttons.

- Register the server (Pro-Server PC) using Pro-Studio on the Pro-Server PC.

The setup contents are as the following.

Node Name : optional node name
 PLC Type : Windows Personal Computer
 IP Address : 192.168.10.10
 Subnet Mask : impossible
 Default Gateway : impossible
 Other Settings : no changes

- Save a Network Project file and transfer the settings to the Factory Gateway.
 Transferring it will set the subnet mask and the default gateway to Factory Gateway.

- Change the network configuration of the Pro-Server PC as the following.

Pro-Server PC's TCP/IP setting

IP Address : 192.168.10.10
 Subnet Mask : 255.255.255.0
 Default Gateway : 192.168.10.1

- Connect the Pro-Server PC to the previous subnet LAN.
- Search Factory Gateway using Factory Gateway Configuration Tool on the Pro-Server PC.
 If Factory Gateway of 192.168.5.5 is displayed after the IP search, the installation has been done successfully.

MEMO

Here, be sure to use [Search for IP] command. [Search] command is unable to search Factory Gateway units on other networks connected via a router.

- Set and transfer the driver from Factory Gateway Configuration Tool.

Reference → “2.4.4 Serial Communication Setup”, “2.4.5 Ethernet Communication Setup”,
 “2.4.6 Provider Information Setup and Transfer”

2.5.2 Subnet Mask settings in the same Subnet

If a Factory Gateway's Subnet Mask settings are not correct even if in the same Subnet, the Factory Gateway might not be searched from Pro-Server PC. If you temporarily set the Subnet Mask to the same class as the IP Address, Factory Gateway Configuration tool can search the Factory Gateway.(If not set the subnet mask, Factory Gateway will understand it as the same class as IP address's set with rotary switches.)
The settings of the subnet mask on Pro-Server PC need to be set back to the previous ones.

When Pro-Server PC and Factory Gateway's Network settings are as following;

Pro-Server PC's TCP/IP settings

IP Address : 172.16.1.1 (Class B)

Subnet Mask : 255.255.255.0 (Class C)

Factory Gateway's Roatory Switch settings

IP Address : 192.168.5.5 (Class B)

1. Change the Pro-Server PC's TCP/IP settings as following.

Pro-Server PC's TCP/IP settings

Subnet Mask : 255.255.0.0 (Class B)

2. Search a Factory Gateway using Pro-Studio.

Factory Gateways can be searched.

3. Change the Pro-Server PC's TCP/IP settings as following.

Factory Gateway's Network Project file settings

Subnet Mask : 255.255.255.0 (Class C)

4. Save the Network Project file and transfer to a Factory Gateway.
5. Restore the Pro-Server PC's Subnet Mask in TCP/IP settings to 255.255.255.0.

3

GP-Viewer & GP-Web

This chapter describes the outline of the GP-Viewer and GP-Web, and the system configuration when you use Factory Gateway units.

3.1 GP-Viewer

3.2 GP-Web

3.1 GP-Viewer

3.1.1 What Is GP-Viewer?

GP-Viewer is the system to display external units' device data such as PLCs in the operation status monitoring window or in the maintenance window on the Pro-Server PC.

You can create windows to display those data using GP-PRO/PB III for Windows, and saves in Factory Gateway. The saved screens can be viewed on the Pro-Server PC via the Pro-Server system.

Device data as sources of screen display are saved as files on the Pro-Server PC, and you can view those past screen data using the Playback feature.

Reference → “Pro-Server with Pro-Studio for Windows Operation Manual”

3.1.2 Outline of GP-Viewer

The following figure shows the outline of GP-Viewer used with Factory Gateway.

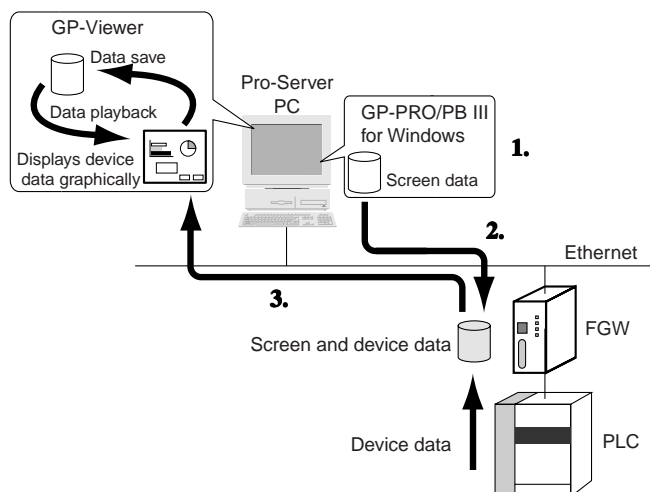

1. Creates screen data using GP-PRO/PB III for Windows.
2. Transfers the created screen data to Factory Gateway using GP-PRO/PB III for Windows.
3. Uploads and displays screen and device data using GP-Viewer.

MEMO

Factory Gateway does not have a screen. Set the GP-Viewer [Option]-[Synchronous Mode] setting to [Async]. To display a screen, configure [Screen No] in the GP-Viewer [Option]-[Display Mode] at the first starting up.
Reference → “Pro-Server with Pro-Studio for Windows Operation Manual”
If you use GP-Viewer V1.1 or later, it will be recognized automatically.

3.1.3 Configuring the System with GP-Viewer

The following figure describes the configuration steps of the Pro-Server system with GP-Viewer on Factory Gateway

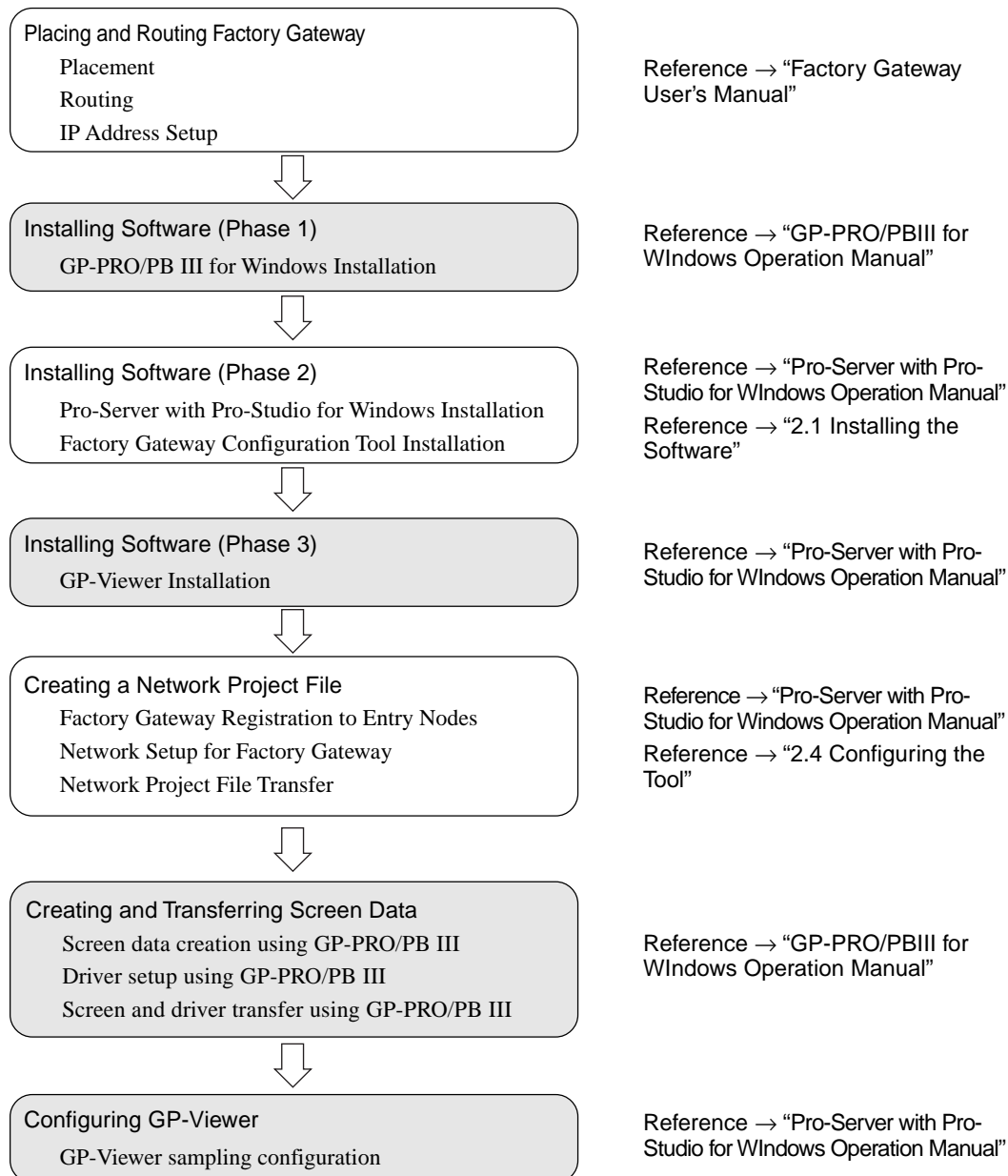

MEMO

- shows steps required additionally when using GP-Viewer.
- If you change a PLC type from Factory Gateway Configuration Tool, screen data will be removed. When you change a driver, you should transfer it from GP-PRO/PB III for Windows. If it's only to change a communication setting, screen data will not be removed and you can change it from Factory Gateway Configuration Tool.

3.2 GP-Web

3.2.1 What Is GP-Web?

GP-Web is the system to display device data of external equipments such PLC on a remote PC connected to Ethernet or the Internet. You can use it for monitoring running state or maintenance.

You can create windows to display those data using GP-PRO/PB III for Windows, and convert to the Web data using GP-Web Compiler. The converted data will be stored on the Pro-Server PC and provided to client PCs with device data sampled by Pro-Server using IIS(Internet service software by Microsoft). Data transferred to client PCs will be displayed on Internet Explorer.

Reference → “GP-Web Operation Manual”

3.2.2 Outline of GP-Web

The following figure shows the outline of GP-Web used with Factory Gateway.

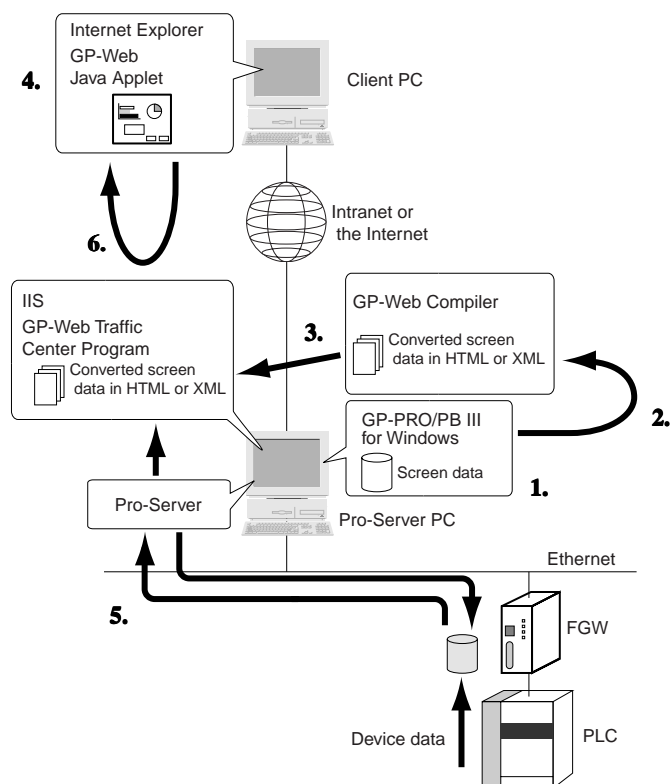

1. Creates screen data using GP-PRO/PB III for Windows.
2. Converts the created screen data using GP-Web Compiler
3. Uploads the converted screen data on the Web using IIS.
4. Request the uploaded page using Internet Explorer on a client PC.
5. Pro-Server samples device data while IIS and GP-Web Traffic Center Program provide those data.
6. Displays provided data on Internet Explorer using GP-Web Java Applet.

MEMO

Factory Gateway does not have a screen. Compile the screen using GP-Web Compiler Screen and Asynchronous setting (default). When starting up, the screen configured in screen data (Project file) is displayed.

Reference → “GP-Web Operation Manual”

3.2.3 Configuring the System with GP-Web

The following figure describes the configuration steps of the Pro-Server system with GP-Web on Factory Gateway.

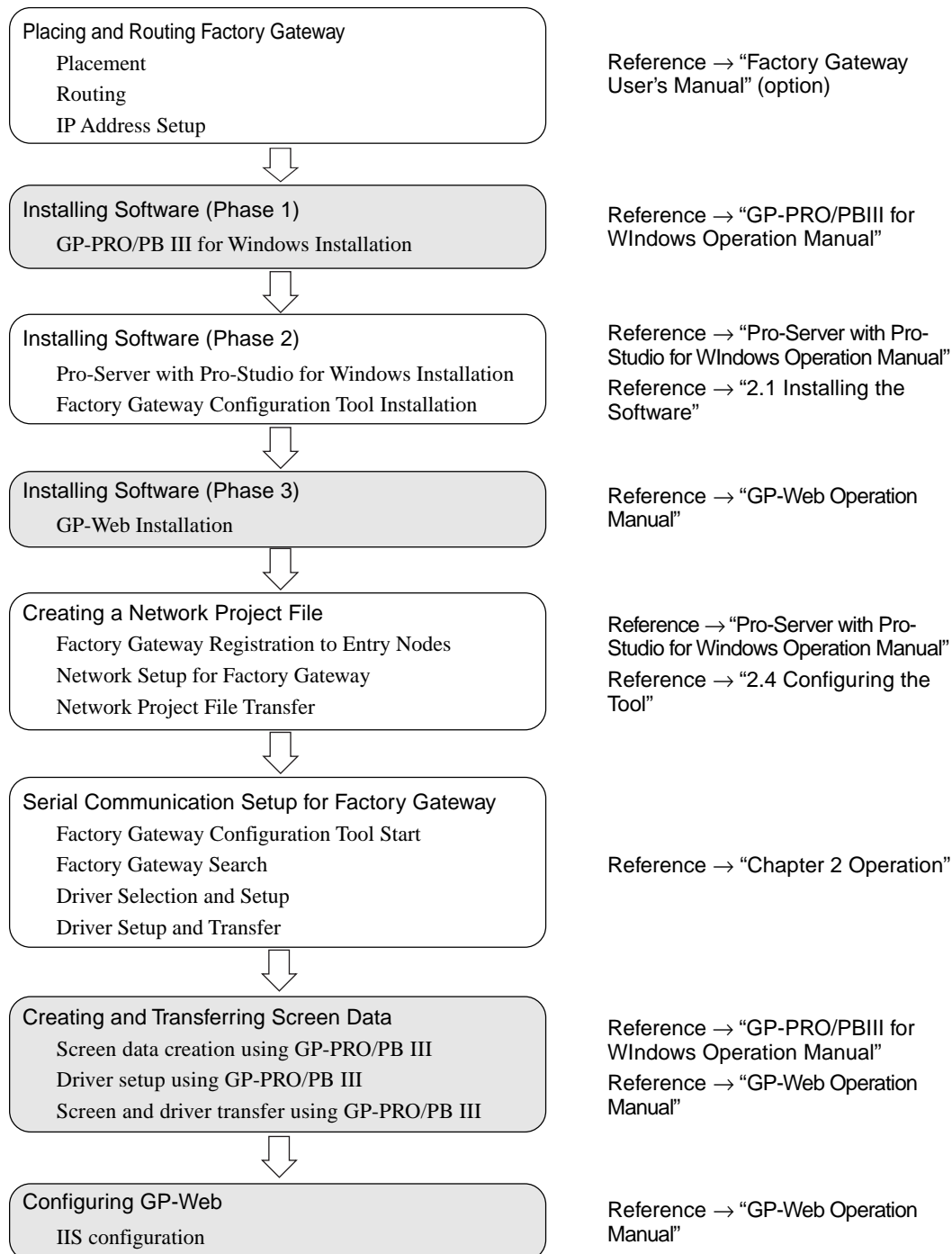

To upload screen data on the Web using the GP-Web system, you need to configure the server or the security.

Reference → “GP-Web Operation Manual”

MEMO  shows steps required additionally when using GP-Viewer.

Appendices

- A.1 Restrictions
- A.2 Error Messages
- A.3 Troubleshooting

A.1 Restrictions

When you use Factory Gateway on the Pro-Server system, following restrictions exist when comparing with the case that you use GP/GLC.

A.1.1 Restrictions on Factory Gateway Unit

- Date and Time Setting

You cannot change the date and time set to Factory Gateway internally on Factory Gateway unit. You should change it from the device monitor on Pro-Studio. (You cannot designate a “second”. It will start from zero when you change the setting.)

The area where the date and time is stored differs depending on the transferred driver.

Reference → “GP-PRO/PB III for Windows Device/PLC Connection Manual” (This is available on our website for downloading.)

- Restriction on Driver

Factory Gateway does not support drivers that require Ethernet types or communication extension units.

The following ethernet protocols are supported:

Memory Link Ethernet Type Protocol, Mitsubishi MELSEC-A (Ethernet) Protocol, Mitsubishi MELSEC-Q (Ethernet) Protocol, Yokogawa Electric FA-M3 (Ethernet) Protocol, Toshiba PROSEC-T (Ethernet) Protocol, MEIDEN RC100 (Ethernet) Protocol, OMRON SYSMAC-CS1 (Ethernet) Protocol

* Although “OMRON SYSMAC-CS1 (Ethernet)”, “Hitachi HIDIC-H(ETHER)”, “SIEMENS S7200 via MPI”, “SIEMENS S7-300/400 via MPI”^{*1}, “Rockwell Allen Bradley SLC500 DH485” and “Rockwell Allen Bradley SLC5/05(ETHER)” protocols are supported by Factory Gateway, you must set them up from GP-PRO/PB III for Windows. When doing this, the protocol must be V1.65 or later.

A.1.2 Restrictions on Pro-Server Features

You cannot use the following Pro-Server features on Factory Gateway.

- SRAM Backup Data Save

Factory Gateway does not have the feature to backup SRAMs. Although files are created, the contents are not saved.

- GP Screen Save

Factory Gateway does not support it, yet, since it does not have a screen. There are no CF Card interfaces that save screen data temporarily, either.

^{*1} When connecting the Factory Gateway unit to multiple PLC units or accessing an extended device, be sure to use GP-PRO/PBIII for Windows to set up the Factory Gateway unit.

- Port Number Change (TCP/UDP Port Number)

You can change the port number used by Factory Gateway on Pro-Server by transferring a network project file from GP-PRO/PB III for Windows via a transfer cable serially. You cannot change it either Pro-Studio or Factory Gateway Configuration Tool.

It is recommended to use the initial value, 8000, as the port number to be used on Pro-Server unless you need to change it.

A.1.3 Restrictions on Action Item “Contents”

You cannot use the following Pro-Server action item contents on Factory Gateway.

- Upload of GP Log Data
- Automatic Upload of GP Filing Data
- Automatic Download of GP Filing Data
- Upload of GP JPEG Data

You cannot use four action item contents described in the above on Factory Gateway because those features require backup SRAMs or CF Cards.

A.1.4 Restrictions on Factory Gateway Configuration Tool

The following restrictions on features exist in Factory Gateway Configuration Tool.

- Multi Link (n:1) Type Driver Setting

You cannot set or transfer a multi link (n:1) type driver on Factory Gateway Configuration Tool. You should set and transfer it using GP-PRO/PB III for Windows.

You can transfer another driver to Factory Gateway where a multi link (n:1) type driver has been set.

- Influence on Screen Data Caused by Driver Transfer

If you transfer a driver from Factory Gateway Configuration Tool, screen data, having been transferred for GP-Viewer, will be removed. When you change a drive of Factory Gateway that transfers screen data for GP-Viewer, you should transfer it using GP-PRO/PB III for Windows. If you change only a communication setting, you can do it on Factory Gateway Configuration Tool and screen data will not be removed at that time.

- Password Setting

You cannot set a password to a driver to be transferred on Factory Gateway Configuration Tool. You should set ([Transfer] Screen - [Setup] - [Password]) and transfer a password that protects a driver from being re-written using GP-PRO/PB III for Windows.

If you try to read Factory Gateway data protected by a password, the dialog box, requesting a password input, will appear. If you enter an appropriate password in the dialog, you will be able to set, change and transfer a driver. If you transfer a driver again from Factory Gateway Configuration Tool, a password set within Factory Gateway will be removed.

- Provider Information at Driver Change

Even when you change and transfer a driver, provider information within Factory Gateway will not be removed. You need to create a network project file for a new driver and transfer it again on Pro-Studio.

A.1.5 Restrictions on GP-PRO/PB III for Windows

The following restrictions on features exist in GP-PRO/PB III for Windows.

- Simulation Feature

You cannot use the simulation feature on Factory Gateway.

- Screen Data Process

Although you can transfer screen data for GP-Viewer, they will not be executed within the Factory Gateway unit. (Features that do not relate to screen displays directly, such as D scripts or data samplings, will not be executed, either. A barcode reader connected to the tool port does not work, either.)

A.1.6 Restrictions on GP-Viewer and GP-Web

The following restrictions on features exist in GP-Viewer and GP-Web.

- Restriction on Tags and Commands

Even in the case of GP-Viewer or GP-Web using Factory Gateway, restrictions on tags and commands exist as same as the case using GP/GLC. For details, see each operation manuals.

Reference → “Pro-Server with Pro-Studio for Windows Operation Manual”, “GP-Web Operation Manual”

- Screen Synchronization

Since Factory Gateway does not have a concept of a screen, you should use it in an asynchronous mode. Also, the screen numbers which screens you display using GP-Viewer and GP-Web need to be registered manually.

A.2 Error Messages

This section describes error messages, workarounds and confirmation items.

Details of workarounds and confirmation items are described in following pages.

Error	Meaning / Trouble Shooting
Communication Error:Target Node does not reply.	No reply from the specified IP Address. - Check the Factory Gateway's power is ON. - Check the designated target node is a Factory Gateway. - Check the Factory Gateway's Network Status LED turns green.
Communication Error:Target Node is not a Factory Gateway.	The specified IP Address is exist but cannot communicate with. - Check the Factory Gateway is operating normally. - Check the Factory Gateway's Network Status LED turns green.
Communication Error:Cannot perform Factory Gateway data readout.	An error occurs while performing the data readout. - Check the Factory Gateway operating normally. - Check the Factory Gateway's Network Status LED turns green.
Communication Error:Cannot perform the data write to the Factory Gateway.	An error occurs while performing the data write. - Check the Factory Gateway is performing normal operation. - Check the Factory Gateway's Network Status LED turns green.
Communication Error:Communication error occurred.	After communicating with a Factory Gateway unit, a communication error occurs. - Check the Factory Gateway is operating normally. - Check the Factory Gateway's Network Status LED turns green.
The password has been canceled.	The password has been canceled. - Enter the correct password to change the driver.
No specified PLC table.	There is no driver information in the PC that is downloading to the Factory Gateway. - Check the driver has been downloaded is for Factory Gateway. - Check Pro-Studio's [Configure]-[System] setting.
No specified driver.	It occurs there is no driver information in PC has been downloaded to the Factory Gateway. - Check the driver has been downloaded is for Factory Gateway. - Check Pro-Studio's [Configure]-[System] setting.
No specified System Loader.	It occurs there is no driver information in PC has been downloaded to the Factory Gateway. - Check Pro-Studio's [Configure]-[System] setting.
System Error	It occurs when this tool received unusual reply from the Factory Gateway. - Check the target node is a Factory Gateway. - Check the Factory Gateway is operating normally.

Error	Meaning / Trouble Shooting
Unable to find designated node.	<p>Factory Gateway not found during search</p> <p>Even though data transfer was attempted using ping, the Factory Gateway unit could not be found. The Factory Gateway unit's subnet mask may differ from that of the PC. Check if the Factory Gateway unit's subnet mask and the PC's subnet mask settings are the same.</p>
Corresponding 2Way driver is not available.	<p>No 2-Way Driver data available in the PC to update the Factory Gateway's 2-Way Driver</p> <p>Please check if the Pro-Studio folder settings (in Pro-Studio's [Configure(S) System] menu) are correct.</p> <p>If GP-PRO/PBIII for Windows is installed, please check if the GP-PRO/PBIII for Windows folder settings (in Pro-Studio's [Configure(S) System] menu) are correct.</p>
..***.*** unit's 2Way Driver data was not updated. Please check if dip switch 6 is set correctly to "ON".	<p>Even though a data transfer error did not occur, the Factory Gateway unit's 2-Way Driver data update failed.</p> <p>One reason may be that the Factory Gateway's Dip Switch 6 is set to OFF. Set this switch to ON to overwrite/update 2-Way Driver data.</p>

■ Check the Factory Gateway's power is ON.

Check if the appropriate power to the specification is supplied.

Check if the power cable has been connected correctly to the power terminal stand.

If the appropriate power is supplied, the PWR LED turns in green.

■ Check the designated target node is a Factory Gateway.

Search it again using Factory Gateway Configuration Tool. If it is Factory Gateway, it will be shown as "Factory Gateway xxxx" in [Node Type] of [List].

You can also check it on Pro-Studio. When you select the node that you wish to check on Pro-Studio and if it is shown as "Factory Gateway xxxx" in [Tools(T)] - [Status Monitor] - [GP Type], then it is Factory Gateway.

■ Check the Factory Gateway's Network Status LED turns green.

Check if the Factory Gateway's network status LED turns in green. If it turns off, it is not connected to Ethernet correctly. Check if the Ethernet cable is correctly connected or if the right kind of the Ethernet cable (straight or cross) is used. If network status LEDs of multiple nodes turn off, the problem seems to exist in Ethernet itself. Consult your network system administrator.

■ Check the Factory Gateway is operating normally.

Select the node that you wish to check on Pro-Studio, and start the status monitor by clicking [Tools(T)] - [Status Monitor]. Check if "Communication Error Code", "Communication Error Code (extended usage)" or "2 Way Error Code" includes any error codes. Error codes from connection units such as PLCs are stored in "Communication Error Code" and in "Communication Error Code (extended usage)". You can check details of "2 Way Error Code" in "Pro-Server with Pro-Studio for Windows Operation Manual".

Reference → "Pro-Server with Pro-Studio for Windows Operation Manual"

■ Check the driver has been downloaded is for Factory Gateway.

Search it again using Factory Gateway Configuration Tool. The driver will be shown in [PLC Type] of [List].

You can also check it on Pro-Studio. Select the node that you wish to check on Pro-Studio, and then the driver within Factory Gateway will be shown in [Tools(T)] - [Status Monitor] - [PLC Type].

You can check supported drivers in Factory Gateway compatible PLC Vendors and Types” in the beginning of this manual. Reference → Factory Gateway compatible PLC Vendors and Types”

■ Check Pro-Studio's [Configure] - [System] setting.

- “Pro-Studio Folder” Check

Check if the folder where Pro-Server with Pro-Studio for Windows has been installed is properly set.

Check if the end of the directory path is closed with “\”. (The default installation location is [C:\Program Files\Pro-face\Pro-Server with Studio\].)

- “GP-PRO/PB III for Windows Folder” Check

Check if the folder where GP-PRO/PB III for Windows has been installed is properly set. Check if the end of the directory path is closed with “\”. (The default installation location is [C:\Program Files\Pro-face\ProPBWin\].)

In the case of PC that GP-PRO/PB III has not been installed, set the path to the folder where Pro-Server with Pro-Studio for Windows has been installed.

■ Check the target node is Factory Gateway.

Search it again using Factory Gateway Configuration Tool. If it is Factory Gateway, it will be shown as “Factory Gateway xxxx” in [Node Type] of [List].

You can also check it on Pro-Studio. When you select the node that you wish to check on Pro-Studio and if it is shown as “Factory Gateway xxxx” in [Tools(T)] - [Status Monitor] - [GP Type], then it is Factory Gateway.

A.3 Troubleshooting

This section describes how to solve problems occurred on the system that uses Factory Gateway.

There are two LEDs on the Factory Gateway unit, PWR and STA that show the status. You can judge causes of those troubles from the status of these LEDs. Detail investigations on causes are described in “Factory Gateway User’s Manual”.

Reference → “Factory Gateway User’s Manual”

There is the method using the status monitor, the device monitor, the provider feature, ProEasy.DLL and so on to check the status of Factory Gateway remotely. This section here describes how to check the status of Factory Gateway remotely.

■ Checking the Status on the Status Monitor

Select the node that you wish to check on Pro-Studio, and start the status monitor by clicking [Tools(T)] - [Status Monitor].

You can check the latest errors by confirming the following contents in the status monitor.

- Communication Error Code
- Communication Error Code (extended usage)
- 2Way Error Code

Error codes from connection units such as PLCs are stored in “Communication Error Code” and “Communication Error Code (extended usage)”. 2Way Driver errors are stored in “2Way Error Code”.

Reference → “A.2.2 2-Way Driver Error Messages and Syslog Features” in “Pro-Server with Pro-Studio for Windows Operation Manual”

■ Checking the Status by Reading the Error Code Storage Area

You can check errors by referring to the error code storage area within Factory Gateway using the device monitor, or user applications using ProEasy.DLL.

The device addresses where errors are stored are as the following.

- LS2039 : Communication Error Code
- LS2070 : Communication Error Code (extended usage)
- LS2075 : 2Way Error Code

Reference → “6.1 Device Monitoring ” and “Chapter 9 Simple DLL Function” in “Pro-Server with Pro-Studio for Windows Operation Manual”

■ Cautions on Communication Error Detection

Communication errors between Factory Gateway and PLC will not be reflected in the error storage area within Factory Gateway until serial communications occur. You need to build the following system to execute remote detections of abnormal status in real time.

- Reading the PLC devices periodically from a user application

Create the program that enables you to read PLC devices connected to Factory Gateway periodically on a user-defined application by ProEasy.DLL.

You can detect communication errors by creating the user-defined application to issue the warning message when the Read function failed to respond.

- Using Provider Feature

Create the provider information provided when the device designated by PLC changes in a network project file, and transfer it to Factory Gateway. Factory Gateway executes serial communications periodically with PLC to check if the designated device has changed.

If there are any problems on PLC and on serial communications, error codes are stored in “LS2039[Communication Error Code]”, in “LS2070[Communication Error Code (extended usage)]” or in “LS2075[2Way Error Code]”. You can detect communication errors by displaying these error code storage areas using GP-Viewer or a user-defined application on the Pro-Server PC.

MEMO

The error codes stored in the error code storage areas are the latest ones. Even if the error status is recovered, the error codes cannot be initialized automatically.