

**GP-PRO/PBIII for Windows  
Device/PLC CONNECTION MANUAL  
ADDITIONAL MANUAL**

**Yasukawa Electric Corporation  
MP2000/MP900/CP9200SH  
Protocol**

**Pro-face**  
*Human Machine Interface* —

## **Reading the GP-PRO/PBIII Device/PLC Connection Manual**

This document is designed as an addition to the latest GP-PRO/PBIII for Windows Device/PLC Connection manual's Yasukawa Electric Corporation data.

When connecting a Factory Gateway unit, please substitute the words "Factory Gateway" for this document's "GP/GLC".

# Installation

This CD-ROM includes all the protocol files required by the GP/GLC to communicate with a Yaskawa Electric Corporation Series PLC. Also, you will need to have one or more of the following software applications installed. The screen and data transfer files included in the CD-ROM must be installed in each of those applications. For information regarding installing the software, refer to that software's Operation Manual.

## ■ Software Applications

- GP-PRO/PBIII for Windows Ver. 2.1 or higher.
- Pro-Server with Pro-Studio for Windows Ver. 3.0 \*1

- 1) Be sure to confirm that the required software application is installed in your PC prior to starting installation.
- 2) Double-click the CD-ROM's "CP9200H.exe" file to start the installation process.
- 3) Once the installation program starts, follow the instructions given to install the protocol files.



- ***When using GP-PRO/PBIII for Windows, be sure to select [Yaskawa Electric Corp.] - [Yaskawa MP2000/MP900/CP9200H] for the "Device/PLC Type".***

---

*\*1 When using the Factory Gateway unit, GP-Web Ver. 1.0 or later or GP-Viewer Ver. 1.0 or later, be sure to select "Pro-Server with Pro-Studio for Windows" as the "Destination Folder".*



## 2.4 Yaskawa Electric

### 2.4.1 System Structure

The following describes the system structure for connecting the GP to Yaskawa PLCs.

**Reference** The Cable Diagrams mentioned in the following tables are listed in the section titled "2.4.2 Cable Diagrams".

#### ■ Memocon-SC Series (using Link I/F)

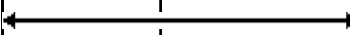
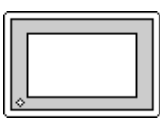
CPU	Link I/F	Cable Diagram	Cables	Target Machine
	SIO Module 			
U84, 84J	JAMSC-C8110	RS-232C (Cable Diagram 1)	Yaskawa Electric Corporation Memory Bus cable JZMSZ-W1015-21 *1 *2	GP/GLC Series
U84S	JAMSC-C8610			ST401
GL40S	JAMSC-IF61 JAMSC-IF41A			
GL60H, GL70H	JAMSC-IF60 JAMSC-IF61			
GL60S	JAMSC-IF60 JAMSC-IF61	RS-232C (Cable Diagram 2)		GP/GLC Series
	JAMSC-IF612			ST401



\*1 Due to the size of its connector case, this cable cannot be used for GP-270, GP-370, GP-377 and GP-377R Series units

\*2 When using an ST401 unit, a 9-pin <-> 25-pin adaptor is required.



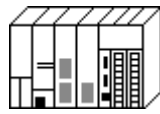

**Note:** When using Multiple Link I/Fs, a maximum of 4 GP units can be connected at the same time.

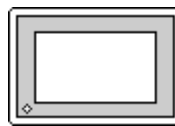
#### ■ Memocon-SC Series (CPU Direct Connection)

CPU	Cable Diagram	Cables	Target Machine
			
GL120	RS-232C (Cable Diagram 3)	Yaskawa Electric Corporation JZMSZ-120W0200-03 *1	GP/GLC Series
			ST401

\*1 When using an ST401 unit, a 9-pin <-> 25-pin adaptor is required.

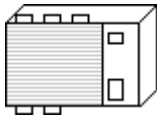
### ■ Control Pack Series (CPU Direct Connection)

CPU <sup>*1</sup>	Cable Diagram	Cables	Target Machine
			
CP-9200 CP-9200H	RS-232C (Cable Diagram 1)	Yaskawa Electric Co. Memo BUS Cable JZMSZ-W1015-21 <sup>*2,3</sup>	GP/GLC Series ST401

\* 1 Connect to CP9200/CP9200H's machine controller (4CN, 6CN).



\* 2 Due to the size of its connector case, this cable cannot be used for GP-270, GP-370, GP-377, GP-377R series.

\* 3 When using an ST401 unit, a 9-pin <-> 25-pin adaptor is required.

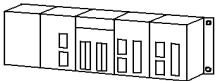

**Note:** Two GPs can be connected to one CP-9200/CP9200H. When using two GPs, set up the GP units so their System Areas do not overlap.

### ■ Control Pack Series (Link I/F)

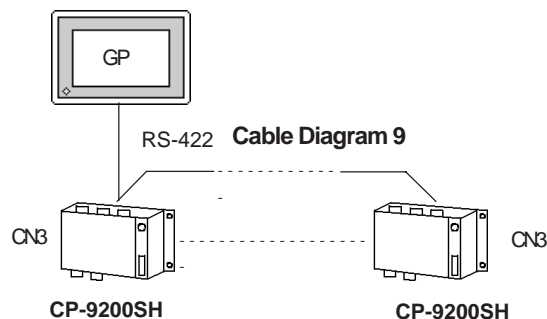

CPU	Link I/F	Cable Diagram	Target Machine
			
CP-9200SH <sup>*1</sup>	JACP-317217(CN1)	RS-232C <Cable Diagram 7>	GP/GLC Series ST401
	JACP-317217(CN2)	RS-232C <Cable Diagram 8>	GP/GLC Series ST401
	JACP-317217(CN3)	RS-422 <Cable Diagram 9>	GP/GLC Series ST400

\* 1 <1:n Connection>



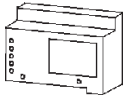

- In this system a total of thirty one (31) CPUs can be connected to one GP. Be sure to connect only ONE GP unit.
- Even though the CPU settings allow 33 or more units to be designated, the GP unit's specifications limit the number to 32. Even though a setting of 33 or more can be entered, the units cannot be used.
- CN1, CN2, CN3 can be connected at the same time.

■ **Memocon Micro (CPU Direct Connection)**

CPU	Cable Diagram	Target Machine
		
Micro <sup>*1</sup>	RS-232C (Cable Diagram 5)	GP/GLC Series
		ST401

\* 1 Connect to **COM1** port.

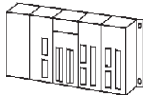
■ **PROGIC-8 Series (using CPU unit Link I/F)**





CPU	Cable Diagram	Cables	Target Machine
			
PROGIC-8 <sup>*1</sup>	RS-232C (Cable Diagram 4)	Yaskawa Electric JEPMC-W5310-03 <sup>*2*3</sup>	GP/GLC Series
			ST401

\* 1 Connect to the PLC unit's **PORT1(9P)** or **PORT2(15P)**.



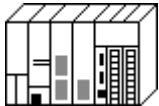

\* 2 Can only use with **PORT1** connection; **PORT2** cannot be used because it has a 15P connector.

\* 3 When using an **ST401**, a 9-pin <-> 25-pin adaptor is required.

■ **Memocon-SC Series (GL 120/GL 130) (using Link I/F)**

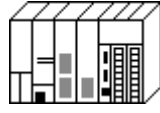
CPU	Link I/F	Cables	Target Machine
	Computer Link Unit 		
GL120 GL130	JAMSC-120MON27100	RS-422 (Cable Diagram 6)	GP/GLC Series
			ST400

■ **MP900 Series** (using Link I/F)



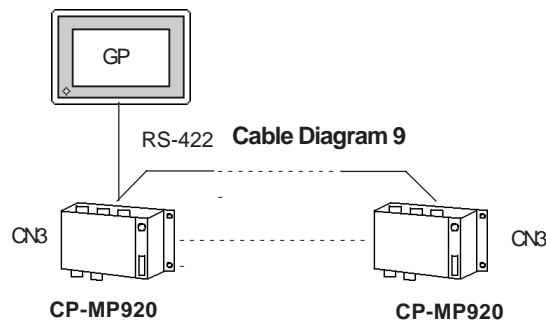

CPU	Link I/F	Cable Diagram	Target Machine
	Computer Link Unit 		
MP930	MEMOBUS Port on CPU unit (Port1, Port2)	RS-232C (Cable Diagram 7)	GP/GLC Series ST401
MP920	MEMOBUS Port on CPU unit (Port1, Port2)	RS-232C (Cable Diagram 7)	GP/GLC Series ST401
	JEPMC-CM200 (CN1, CN2)		GP/GLC Series ST401
	JEPMC-CM200 *1 (CN3)	RS-422 (Cable Diagram 9)	GP/GLC Series ST400

\* 1 <1:n Connection>

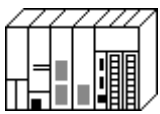

- In this system a total of thirty one (31) CPUs can be connected to one GP. Be sure to connect only ONE GP unit.
- Even though the CPU settings allow 33 or more units to be designated, the GP unit's specifications limit the number to 32. Even though a setting of 33 or more can be entered, the units cannot be used.
- PORT1, PORT2, CN1, CN2, CN3 can be connected at the same time.

■ **MP2300 Series (using Link I/F)**

CPU	Link I/F	Cable Diagram	Target Machine
			
MP2300	RS232C Serial Connector on General Serial Communication Module 217IF-01	RS-232C (Cable Diagram 10)	GP/GLC Series ST401
		RS-422 1:1 Communication (Cable Diagram 11)	GP/GLC Series ST400
	RS422/485 Serial Connector on General Serial Communication Module 217IF-01	RS-422 1:1 Communication (Cable Diagram 12) *1	GP/GLC Series ST400
		Serial Connector on Ethernet Communication Module 218IF-01	RS-232C (Cable Diagram 10)

\* 1 <1:n Connection>

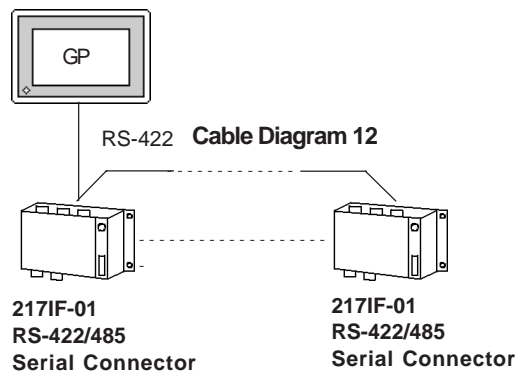

- **In this system a total of thirty one (31) CPUs can be connected to one GP. Be sure to connect only ONE GP unit.**
- **Even though the CPU settings allow 33 or more units to be designated, the GP unit's specifications limit the number to 32. Even though a setting of 33 or more can be entered, the units cannot be used.**
- **The 217IF-01 RS-232C Serial Connector and the 217IF-01 RS-422/485 Serial Connector can be used at the same time.**



## 2.4.2 Cable Diagrams

The cable diagrams illustrated below and the cable diagrams recommended by Yaskawa Electric Corporation may differ. Using these cables for your PLC operations, however, will not cause any problems.



*Ground your PLC's FG terminal according to your country's applicable standard. For details, refer to the corresponding PLC manual.*



- **Connect the FG line of the Shield cable to either the GP or PLC, depending on your environment. When using a connector hood and grounding the FG line, be sure to use an electrical conductor. The following connection diagrams show examples for connecting a shielded cable to the PLC.**
- **For the RS-232C connection, use a cable length less than 15m.**
- **For the RS-422 connection, use a cable length less than 300m.**
- **If a communications cable is used, it must be connected to the SG (signal ground).**

Cable Diagram 1 (RS-232C)

### GP/GLC Series Units

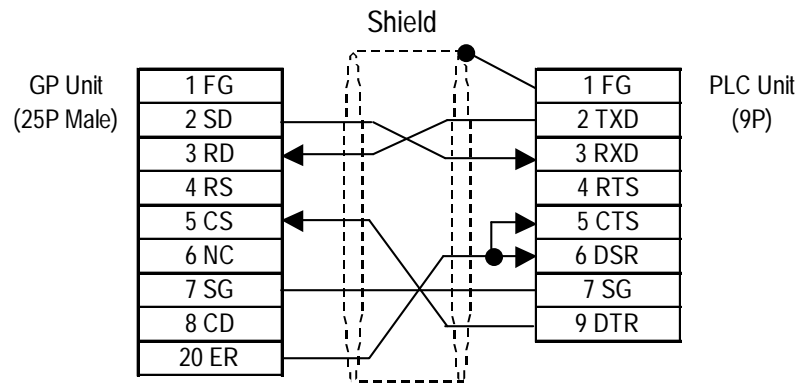

### ST401 Unit

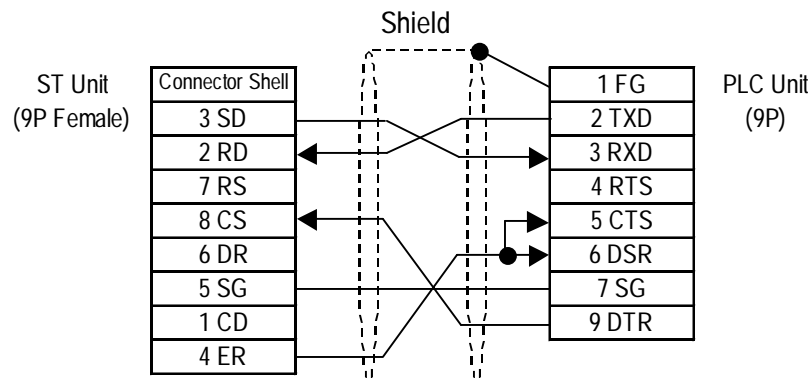

## Cable Diagram 2 (RS-422)

### GP/GLC Series Units

- When using Digital's RS-422 connector terminal adapter GP070-CN10-0

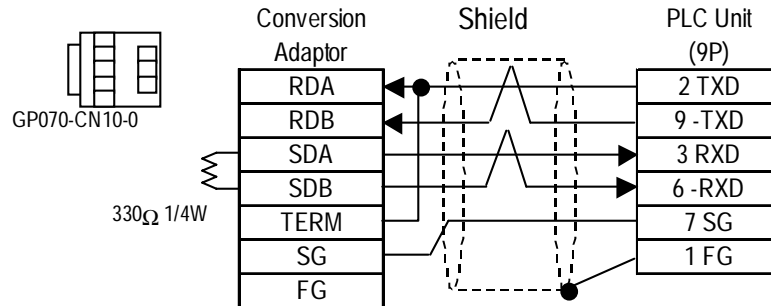

- When using Digital's RS-422 Cable, GP230-IS11-0

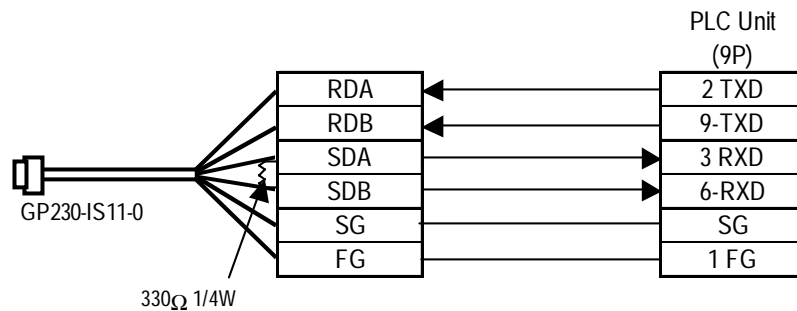

- When making your own cable connections

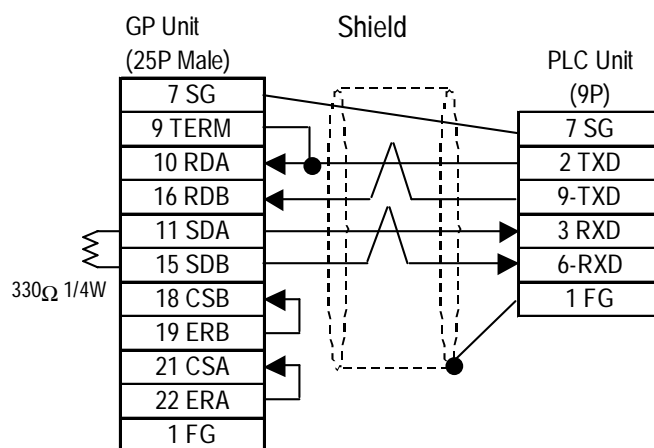

**Note:** When connecting the #9 and #10 pins in the GP Serial I/F, a termination resistance of 100Ω is added between RDA and RDB.

### ST400 Unit

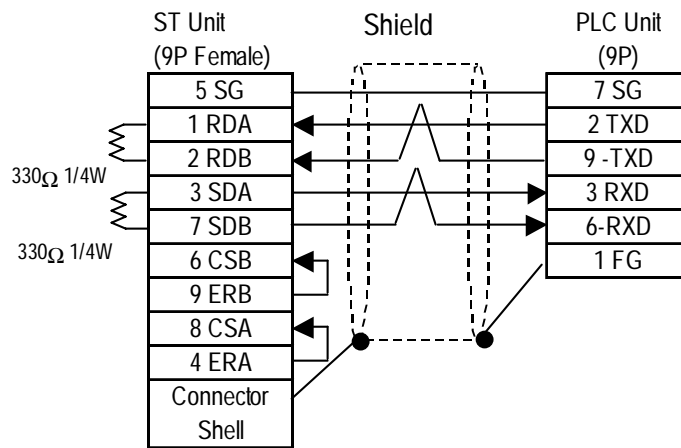

### Cable Diagram 3 (RS-232C)

#### GP/GLC Series Units

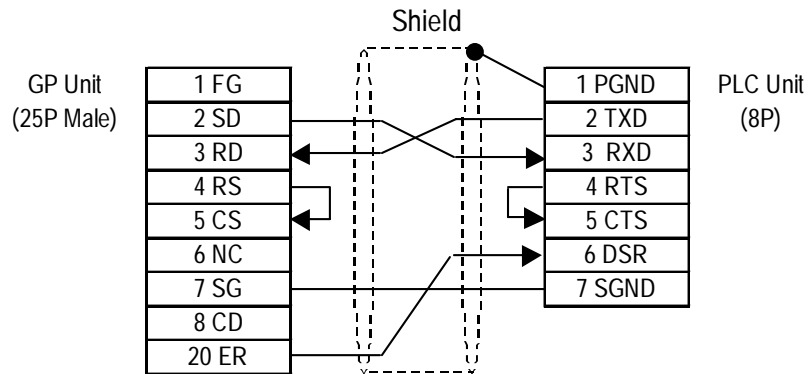

### ST401 Unit

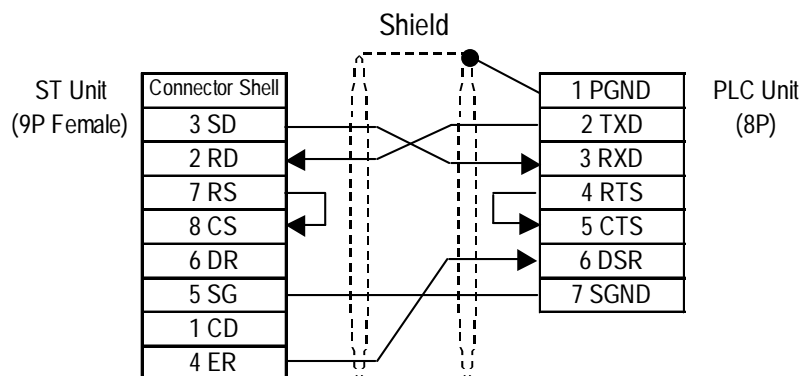

### Cable Diagram 4 (RS-232C)

#### GP/GLC Series Units

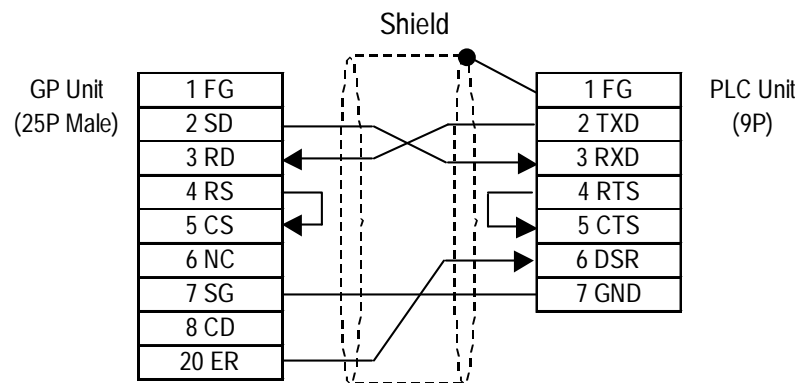

#### ST401 Unit

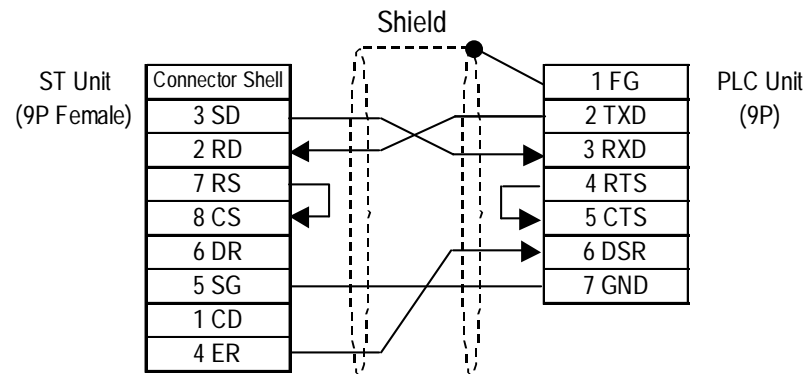

### Cable Diagram 5 (RS-232C)



**Note:** The PLC uses an RJ45 jack.

The pin numbers of the modular-jack for the connection diagrams below are based on the order shown in this figure.

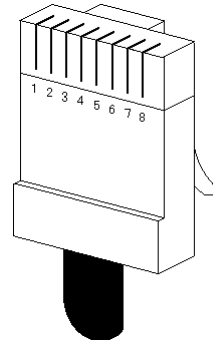

#### GP/GLC Series Units

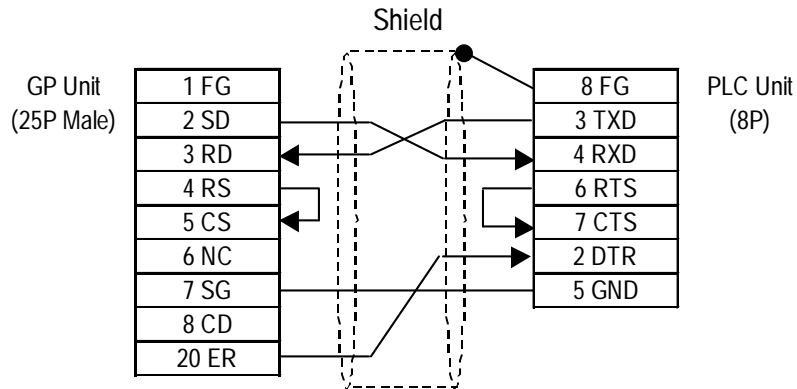

#### ST401 Unit

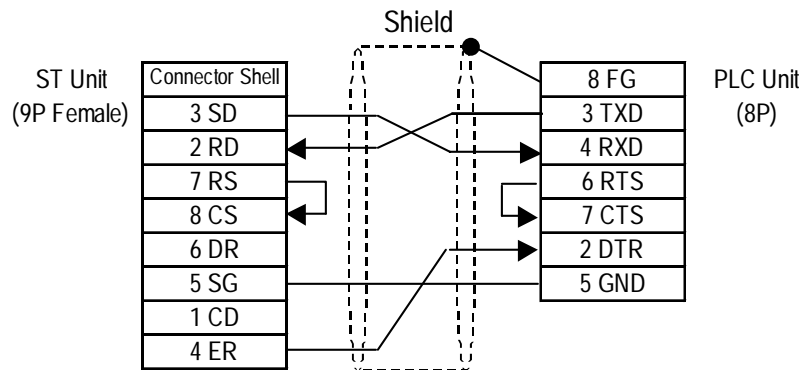

### Cable Diagram 6 (RS-422)

#### GP/GLC Series Units

- When using Digital's RS-422 connector terminal adapter GP070-CN10-0

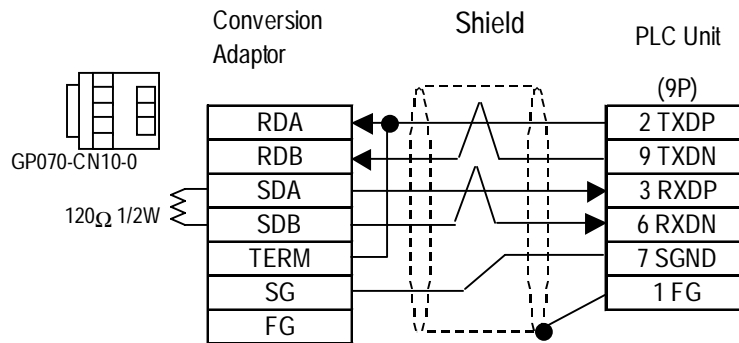

- When using Digital's RS-422 Cable, GP230-IS11-0

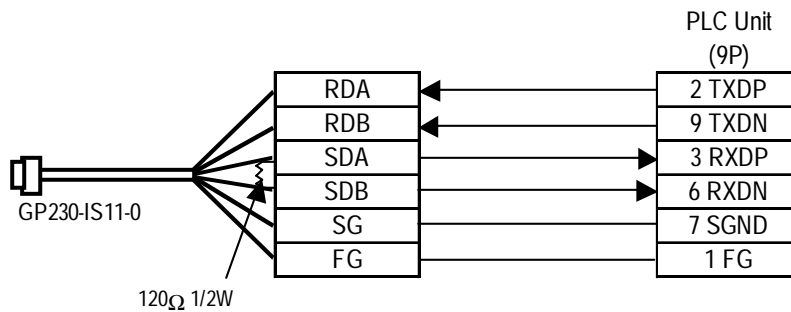

- When making your own cable connections

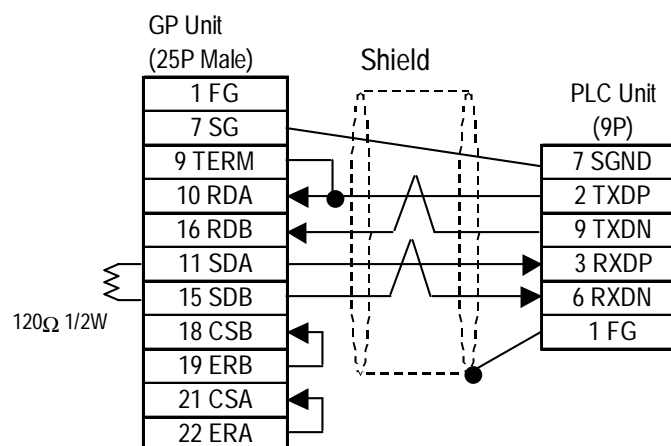

**Note:** Connecting the #9 and #10 pins in the GP Serial I/F adds a termination resistance of 100Ω between RDA and RDB.

### ST400 Unit

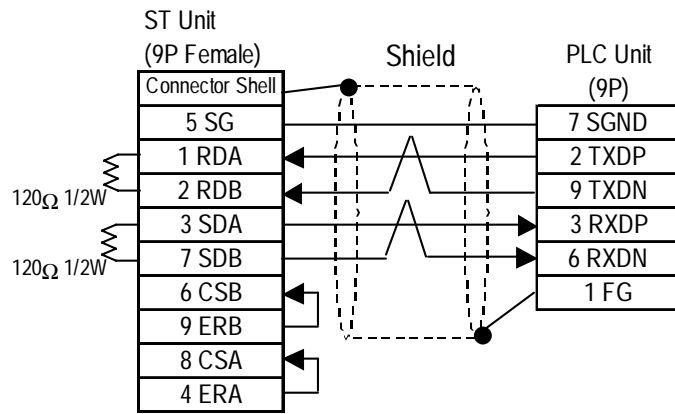

### Cable Diagram 7 (RS-232C)

#### GP/GLC Series Units

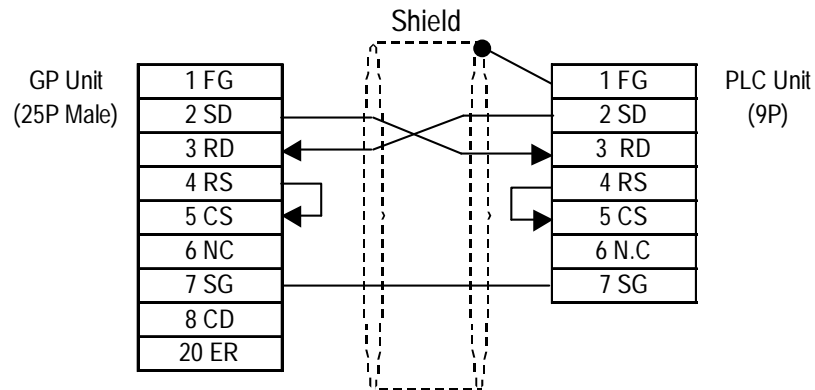

### ST401 Unit

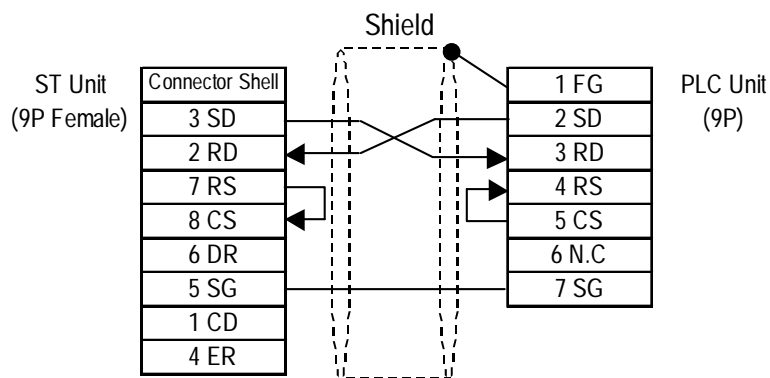

### Cable Diagram 8 (RS-232C)

#### GP/GLC Series Units

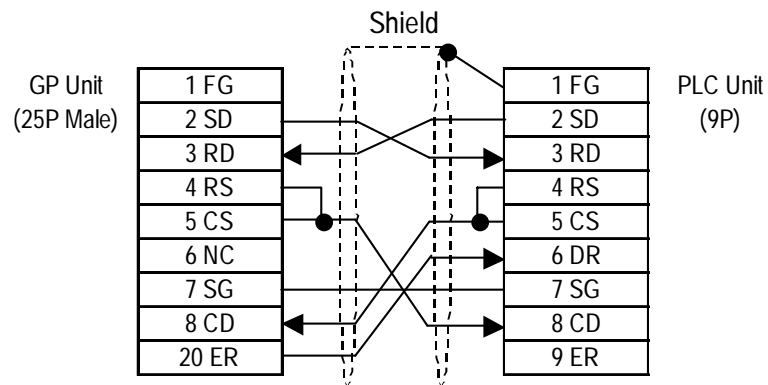

#### ST401 Unit

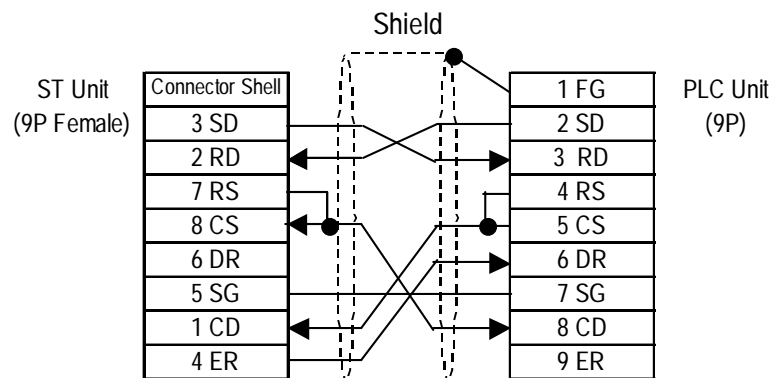



### Cable Diagram 9 (RS-422)

#### GP/GLC Series Units

- When using Digital's RS-422 Connector terminal adapter GP070-CN10-0.

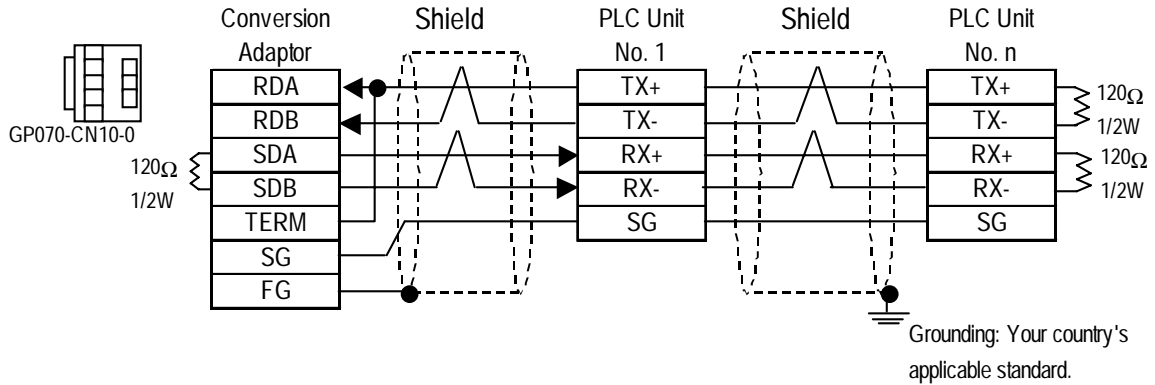

- When using Digital's RS-422 Cable, GP230-IS11-O.

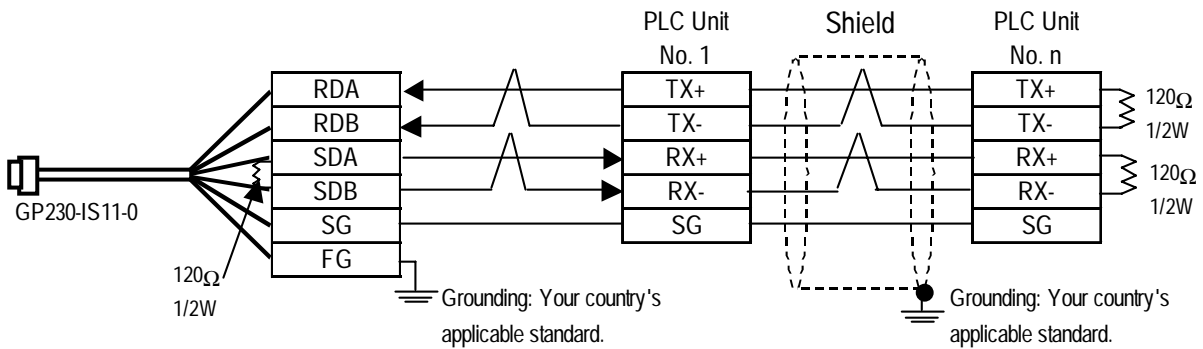

- When making your own cable connections

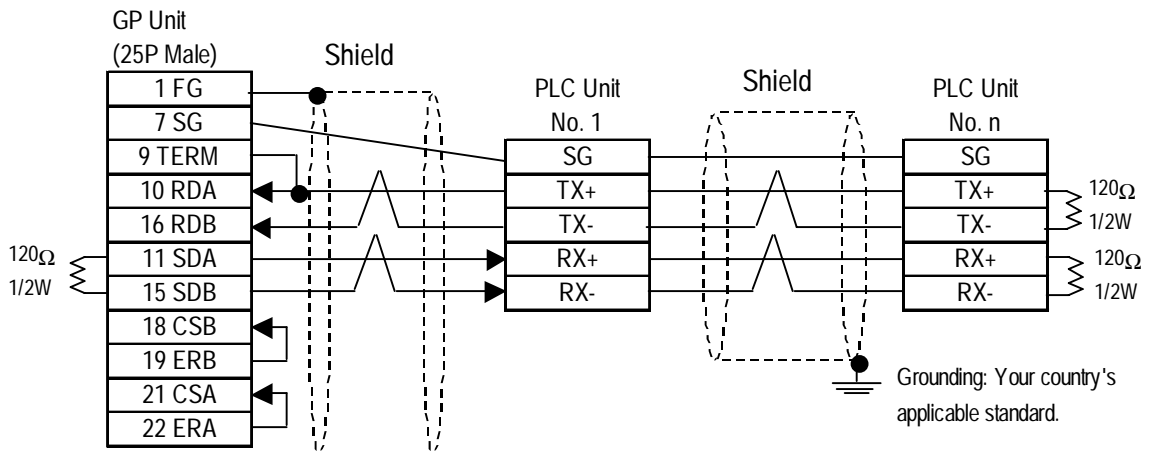

### ST400 Unit

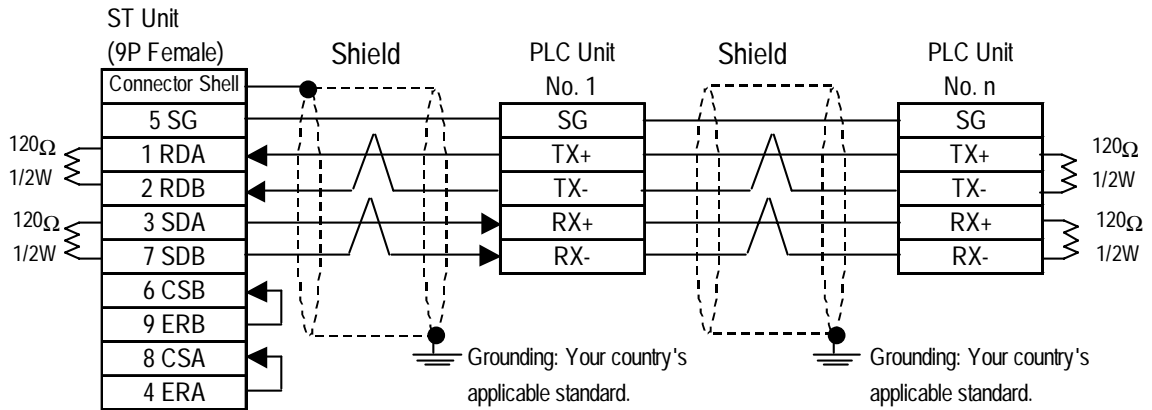

### Cable Diagram 10 (RS-232C)

#### GP/GLC Series Units

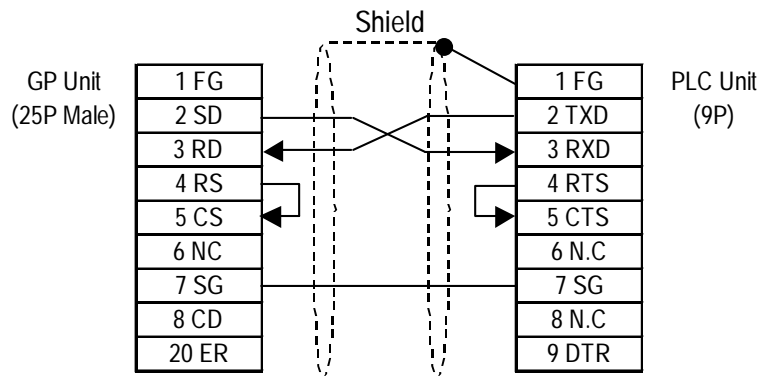

### ST401 Unit

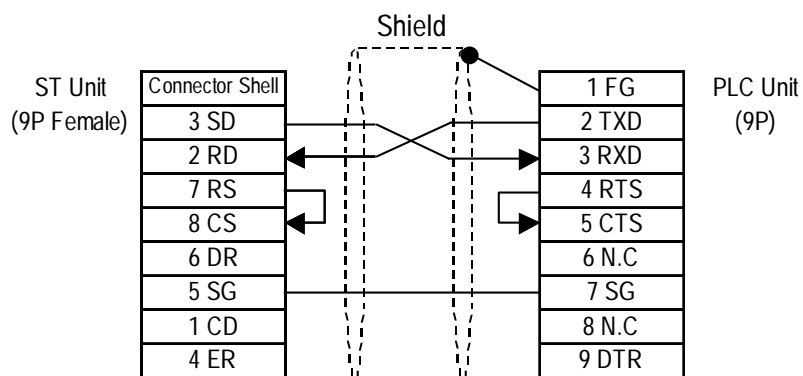

### Cable Diagram 11 (RS-422)

#### GP/GLC Series Units

- When using Digital's RS-422 connector terminal conversion adaptor, GP070-CN10-0

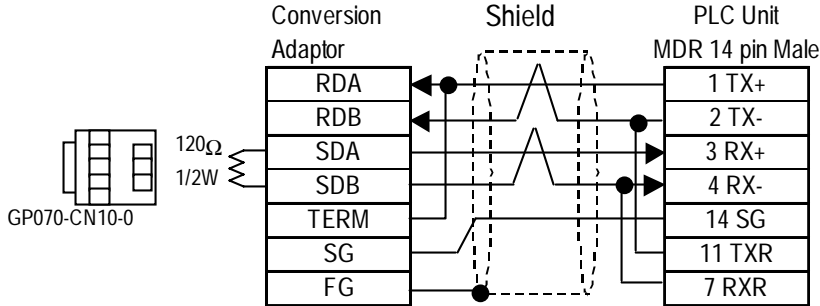

- When making your own cable connections

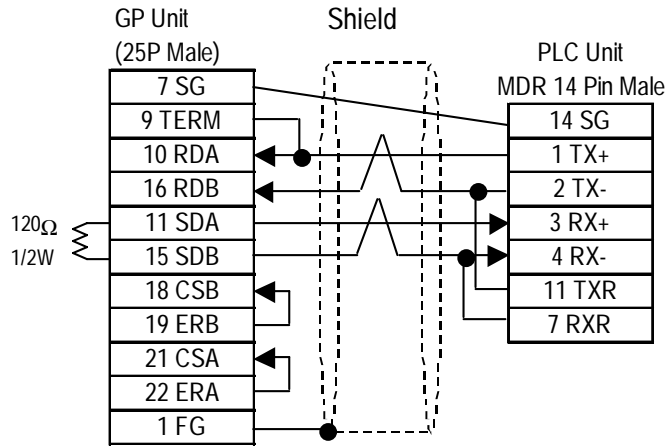

**Note:** Connecting TX- to TXR and RX- to RXR on the PLC side adds a termination resistance of 120Ω.

#### ST400 Unit

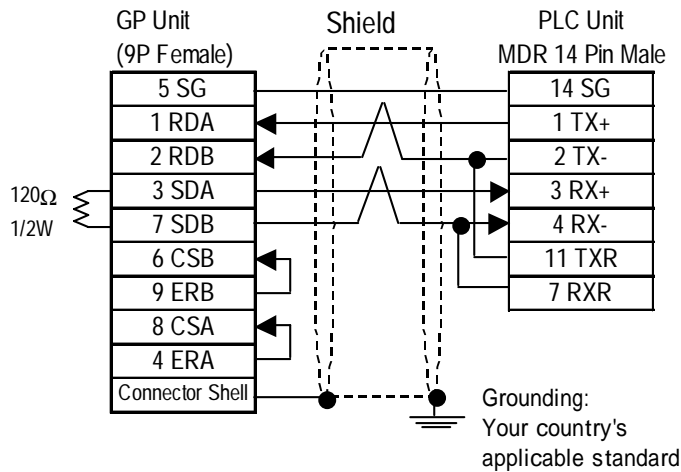

## Cable Diagram 12 (RS-422)

### GP/GLC Series Units

- When using Digital's RS-422 connector terminal conversion adaptor, GP070-CN10-0

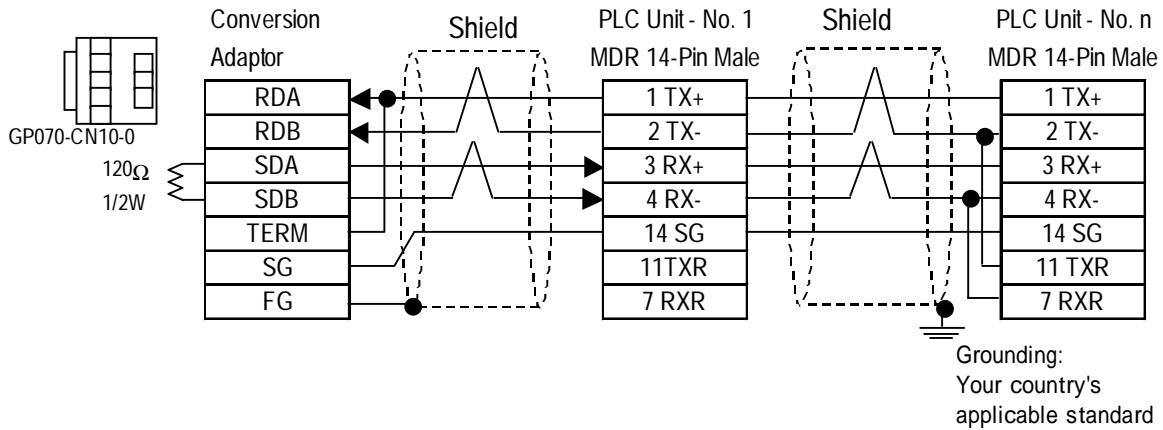

- When making your own cable connections

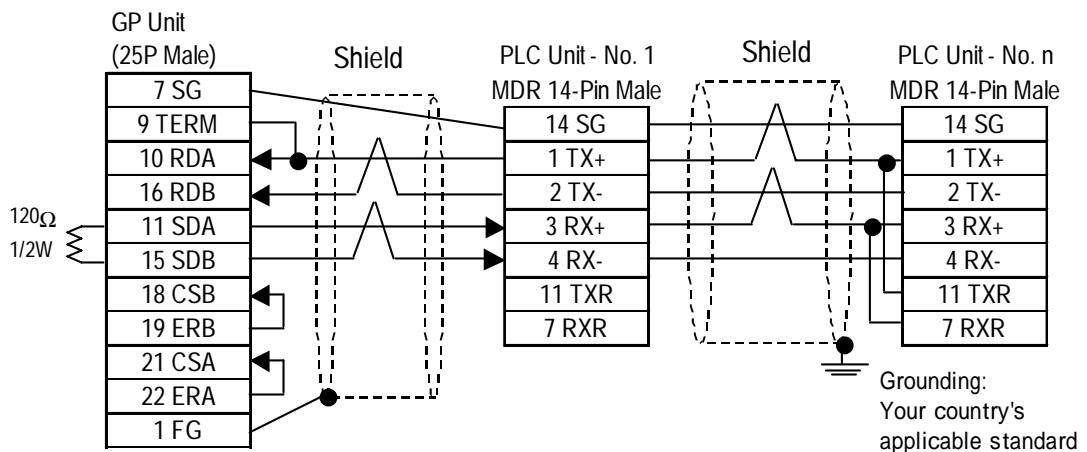

### ST400 Unit

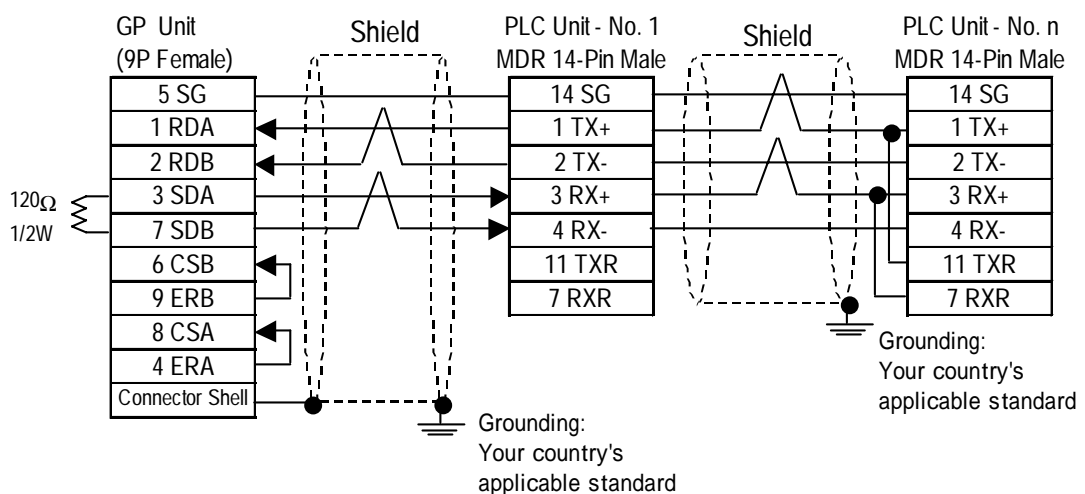





### 2.4.3 Supported Devices

The following describes the range of devices supported by the GP.

#### ■ Memocon-SC Series

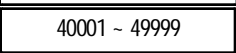
(U84/84J/U84S/GL40S/GL60H/GL70H/GL60S)

 Setup System Area here.

Device	Bit Address	Word Address	Particulars	
Coil (Output/Internal)	00001 ~ 08192	---	'1	H/L
Input Relay	10001 ~ 14096	---	'1 '2	
Link Coil	D0001 ~ D1024	---	'1	
Input Register	---	30001 ~ 30512	 '2	
Output/Keep Register	---	 40001 ~ 49999		
Link Register	---	R0001 ~ R1024		
Constant Register	---	31001 ~ 35096		
Extended Register	---	A0000 ~ A7FFF		

## ■ Memocon-SC Series (GL120/GL130)

     Setup System Area here.

Device	Bit Address	Word Address	Particulars	
Coil (Output / Internal)	000001 ~ 008192	---		"1
Input Relay	100001 ~ 101024	---		"1 "2
Link Coil 1	D10001 ~ D11024	---		"1
Link Coil 2	D20001 ~ D21024	---		"1
MC Relay 1	X10001 ~ X10256	---		"1 "2
MC Relay 2	X20001 ~ X20256	---		"1 "2
MC Coil 1	Y10001 ~ Y10256	---		"1
MC Coil 2	Y20001 ~ Y20256	---		"1
MC Code Relay 1	M10001 ~ M10096	---		"1 "2
MC Code Relay 2	M20001 ~ M20096	---		"1 "2
MC Control Relay 1	P10001 ~ P10256	---		"1 "2
MC Control Relay 2	P20001 ~ P20256	---		"1 "2
MC Control Coil 1	Q10001 ~ Q10256	---		"1
MC Control Coil 2	Q20001 ~ Q20256	---		"2
Input Register	---	300001 ~ 300512	<span style="border: 1px solid black; padding: 2px;">Bit 5</span>	"2
Output Register	---	300001 ~ 300512	<span style="border: 1px solid black; padding: 2px;">Bit 5</span>	
Keep Register	---	400001 ~ 409999	<span style="border: 1px solid black; padding: 2px;">Bit 5</span>	
Link Register 1	---	R10001 ~ R11024	<span style="border: 1px solid black; padding: 2px;">Bit 5</span>	
Link Register 2	---	R20001 ~ R21024	<span style="border: 1px solid black; padding: 2px;">Bit 5</span>	
Constant Register	---	700001 ~ 704096	<span style="border: 1px solid black; padding: 2px;">Bit 5</span>	

H/L

\* 1 Can also specify as a word (16 bit data)

\* 2 Cannot perform data write.

■ Control Pack Series

Setup System Area here.

Device	Bit Address	CP-9200/CP-9200H's Register No. Corresponding to Address	Particulars
Input Register	00001 ~ 02048	IB00000 ~ IB007FF	*1
Output Register	02049 ~ 04096	OB00000 ~ OB007FF	*1
System Register	10001 ~ 12048	SB000000 ~ SB00127F (CPU#0's S-Register)	*1

L/H

Device	Word Address	CP-9200/CP-9200H's Register No. Corresponding to Address	Particulars
Input Register	49744 ~ 49871	IB00000 ~ IB007FF	<span style="border: 1px solid black; padding: 2px;">Bit 15</span>
Output Register	49872 ~ 49999	OB00000 ~ OB007FF	<span style="border: 1px solid black; padding: 2px;">Bit 15</span>
System Register	30001 ~ 30256	SW00000 ~ SW00255 (CPU#0's S-Register)	<span style="border: 1px solid black; padding: 2px;">Bit 15</span>
Data Register	31001 ~ 33048 (CP-9200H only)	DW00000 ~ DW02047 (CPU#1's D-Register)	<span style="border: 1px solid black; padding: 2px;">Bit 15</span>
	40001 ~ 42048	DW00000 ~ DW02047 (CPU#0's D-Register)	<span style="border: 1px solid black; padding: 2px;">Bit 15</span>
Common Register	42049 ~ 49743	MW00000 ~ MW07694	<span style="border: 1px solid black; padding: 2px;">Bit 15</span>

L/H

\* 1 Can also specify as a word (16 bit data).



- If the above devices are used in the Control Pack series, the addresses converted using the above table should be entered.
- When you wish to use a CP-9200 together with CPU#1's Data Register or the System Register, be sure to copy data to the Common Register (MW00000 ~ MW07694) first.

■ Memocon Micro

Setup System Area here.

Device	Bit Address	Word Address	Particulars
Coil (Output/Internal)	00001 ~ 01531	---	*1
Input Relay	10001 ~ 10511	---	*1
Input Register	---	30001 ~ 30047	<span style="border: 1px solid black; padding: 2px;">Bit 15</span>
Output/Keep Register	---	40001 ~ 41871	<span style="border: 1px solid black; padding: 2px;">Bit 15</span>

H/L

\* 1 Can also specify as a word (16 bit) data.

■ **PROGIC-8 Series**

Setup System Area here.

Device	Bit Address	Word Address	Particulars
Output Coil	O1 ~ O512	---	*1
Input Relay	I1 ~ I512	---	*1 *2
Internal Coil	N1 ~ N1536	---	*1
Link Coil	D1 ~ D1024	---	*1
Data Register	---	W1 ~ W2048	<span style="border: 1px solid black; padding: 2px;">Bit 15</span>
Data Register (1-word data)	---	SW1 ~ SW2048	<span style="border: 1px solid black; padding: 2px;">Bit 15</span> *3
Data Register (2-word data)	---	DW1 ~ DW2048	<span style="border: 1px solid black; padding: 2px;">Bit 15</span> *3
Input Register	---	Z1 ~ Z128	*2
Link Register	---	R1 ~ R1024	
Link (1-word data)	---	SR1 ~ SR2048	*3
Link (2-word data)	---	DR1 ~ DR2048	*3

\* 1 Can also specify as a word (16 bit data)

\* 2 Cannot perform data write.

\* 3 A data format compatible register. This is a virtual register applicable for the data in the PLC. It uses data register (W) and link register (R). The range of data which can be handled as 1-word is -9999 to 9999.

1) Cautions related to using data register (SW) and link register (SR) are applicable to 1-word data.

If the SW and the SR are used, be sure to use values in the range from -9999 to 9999. Data must be displayed in four digits (decimal notation).

**Differences in displayed values between SW, SR and W, R**

Data in the PLC	SW, SR	W, R
9999	9999	9999
1001	1001	1001
1000	1000	1000
999	999	999
0	0	0
-1	-1	32769
-999	-999	33767
-1000	-1000	33768
-1001	-1001	33769
-9999	-9999	42767

(Continued on next page)



2) Cautions related to using a register applicable for 2-word data.

Using data register (DW) and link register (DR)

If the DW and the DR are used, be sure to use values in the range from -9999 to 9999. Data must be displayed in four digits (decimal notation).

**Differences in displayed values between DW, DR and W, R (2-word)**

Data in the PLC	DW, DR	W, R
99999999	99999999	655304463
10000001	10000001	65536001
10000000	10000000	65536000
99999999	99999999	65535999
10000	10000	65536
9999	9999	9999
0	0	0
-1	-1	2147483649
-9999	-9999	2147493647
-10000	-10000	2147549184
-10001	-10001	2147549185
-99999999	-99999999	2212955111

## ■ CP-9200SH / MP900 Series

     Setup System Area here.

Device	GP Device Address	CP-9200SH Device	Amount	Particulars	
Coil (bit device)	GMB00000 ~ GMB0624E	MB000000 + OFFSET to MB00624E + OFFSET	9999		
Coil (word device)	GMB00000 ~ GMB0624	MB00000 + OFFSET to MB00624 + OFFSET	625		*2
Input Relay (bit device)	GIB00000 ~ GIB0270E	IB00000 + OFFSET to IB0270E + OFFSET	9999		*1
Input Relay (word device)	GIB0000 ~ GIB0270	IB00000 + OFFSET to IB0270 + OFFSET	625		*1 *2
Hold Register (word device)	GMW0000 ~ GMW1023	MW00000 + OFFSET to MW01023 + OFFSET	1024	<span style="border: 1px solid black; padding: 2px;">Bit F</span>	L/H
	GMW1024 ~ GMW2047	MW01024 + OFFSET to MW02047 + OFFSET	1024	<span style="border: 1px solid black; padding: 2px;">Bit F</span>	
	GMW2048 ~ GMW3071	MW02048 + OFFSET to MW03071 + OFFSET	1024	<span style="border: 1px solid black; padding: 2px;">Bit F</span>	
	GMW3072 ~ GMW4095	MW03072 + OFFSET to MW04095 + OFFSET	1024	<span style="border: 1px solid black; padding: 2px;">Bit F</span>	
	GMW4096 ~ GMW5119	MW04096 + OFFSET to MW05119 + OFFSET	1024	<span style="border: 1px solid black; padding: 2px;">Bit F</span>	
	GMW5120 ~ GMW6143	MW05120 + OFFSET to MW06143 + OFFSET	1024	<span style="border: 1px solid black; padding: 2px;">Bit F</span>	
	GMW6144 ~ GMW7167	MW06144 + OFFSET to MW07167 + OFFSET	1024	<span style="border: 1px solid black; padding: 2px;">Bit F</span>	
	GMW7168 ~ GMW8191	MW07168 + OFFSET to MW08191 + OFFSET	1024	<span style="border: 1px solid black; padding: 2px;">Bit F</span>	
	GMW8192 ~ GMW9215	MW08192 + OFFSET to MW09215 + OFFSET	1024	<span style="border: 1px solid black; padding: 2px;">Bit F</span>	
	GMW9216 ~ GMW9998	MW09216 + OFFSET to W09998 + OFFSET	783	<span style="border: 1px solid black; padding: 2px;">Bit F</span>	
Input Register (word device)	GIW0000 ~ ~ GIW03FF	IW00000 + OFFSET to IW03FF + OFFSET	1024	<span style="border: 1px solid black; padding: 2px;">Bit F</span>	*1
	GIW0400 ~ GIW07FF	IW0400 + OFFSET to IW07FF + OFFSET	1024	<span style="border: 1px solid black; padding: 2px;">Bit F</span>	*1
	GIW0800 ~ GIW08FF	IW0800 + OFFSET to IW08FF + OFFSET	1024	<span style="border: 1px solid black; padding: 2px;">Bit F</span>	*1
	GIW0C00 ~ GIW0FFF	IW0C00 + OFFSET to IW0FFF + OFFSET	1024	<span style="border: 1px solid black; padding: 2px;">Bit F</span>	*1
	GIW1000 ~ GIW13FF	IW1000 + OFFSET to IW13FF + OFFSET	1024 *Device range "0000" indicates it is hexa-decimal	<span style="border: 1px solid black; padding: 2px;">Bit F</span>	*1

\*1 Can be read out from a GP, however cannot be written to a GP.

\*2 Cannot be written in the last (16th) bit of this address.(i.e, GMB0624/GIB0270)























## ■ MP2300 Series

Device	GP Device Address	MP2300 Devices	No. of Devices	Remarks
Coil (Bit Device)	GMB00000 to GMB1023F	MB00000 + offset to MB1023F + offset	16384 bits	L/H
	GMB10240 to GMB2047F	MB10240 + offset to MB2047F + offset	16384 bits	
	GMB20480 to GMB3071F	MB20480 + offset to MB3071F + offset	16384 bits	
	GMB30720 to GMB4095F	MB30720 + offset to MB4095F + offset	16384 bits	
Coil (Word Device)	GMB0000 to GMB1023	MB0000 + offset to MB1023 + offset	1024 words	
	GMB1024 to GMB2047	MB1024 + offset to MB2047 + offset	1024 words	
	GMB2048 to GMB3071	MB2048 + offset to MB3071 + offset	1024 words	
	GMB3072 to GMB4095	MB3072 + offset to MB4095 + offset	1024 words	
Input Relay (Bit Device)*1	GIB00000 to GIB03FFF	IB00000 + offset to IB03FFF + offset	16384 bits	
	GIB04000 to GIB07FFF	IB04000 + offset to IB07FFF + offset	16384 bits	
	GIB08000 to GIB0BFFF	IB08000 + offset to IB0BFFF + offset	16384 bits	
	GIB0C000 to GIB0FFFF	IB0C000 + offset to IB0FFFF + offset	16384 bits	
Input Relay (Word Device)*1	GIB0000 to GIB03FF	IB0000 + offset to IB03FF + offset	1024 words	
	GIB0400 to GIB07FF	IB0400 + offset to IB07FF + offset	1024 words	
	GIB0800 to GIB0BFF	IB0800 + offset to IB0BFF + offset	1024 words	
	GIB0C00 to GIB0FFF	IB0C00 + offset to IB0FFF + offset	1024 words	

(Continued on following page.)

\*1 Can be read out from a GP, however cannot be written to a GP. When data write is attempted to a GP, a "Receive Data Error" (02:FC:\*\*\*) will be displayed. (\*\*\*) is the GP unit number.)























■ **MP2300 Series** (Continued from previous page)

Device	GP Device Address	MP2300 Devices	No. of Devices	Remarks
Hold Register (Word Device)	GMW00000 to GMW01023	MW00000 + offset to MW01023 + offset	1024 Words	
	GMW01024 to GMW02047	MW01024 + offset to MW02047 + offset	1024 Words	
	GMW02048 to GMW03071	MW02048 + offset to MW03071 + offset	1024 Words	
	GMW03072 to GMW04095	MW03072 + offset to MW04095 + offset	1024 Words	
	GMW04096 to GMW05119	MW04096 + offset to MW05119 + offset	1024 Words	
	GMW05120 to GMW06143	MW05120 + offset to MW06143 + offset	1024 Words	
	GMW06144 to GMW07167	MW06144 + offset to MW07167 + offset	1024 Words	
	GMW07168 to GMW08191	MW07168 + offset to MW08191 + offset	1024 Words	
	GMW08192 to GMW09215	MW08192 + offset to MW09215 + offset	1024 Words	
	GMW09216 to GMW10239	MW09216 + offset to MW10239 + offset	1024 Words	
	GMW10240 to GMW11263	MW10240 + offset to MW11263 + offset	1024 Words	
	GMW11264 to GMW12287	MW11264 + offset to MW12287 + offset	1024 Words	
	GMW12288 to GMW13311	MW12288 + offset to MW13311 + offset	1024 Words	
	GMW13312 to GMW14335	MW13312 + offset to MW14335 + offset	1024 Words	
	GMW14336 to GMW15359	MW14336 + offset to MW15359 + offset	1024 Words	
	GMW15360 to GMW16383	MW15360 + offset to MW16383 + offset	1024 Words	
	GMW16384 to GMW17407	MW16384 + offset to MW17407 + offset	1024 Words	
	GMW17408 to GMW18431	MW17408 + offset to MW18431 + offset	1024 Words	
	GMW18432 to GMW19455	MW18432 + offset to MW19455 + offset	1024 Words	
	GMW19456 to GMW20479	MW19456 + offset to MW20479 + offset	1024 Words	
GMW20480 to GMW21503	MW20480 + offset to MW21503 + offset	1024 Words		
GMW21504 to GMW22527	MW21504 + offset to MW22527 + offset	1024 Words		

L/H

(Continued on following page.)

























■ **MP2300 Series** (Continued from previous page)

Device	GP Device Address	MP2300 Devices	No. of Devices	Remarks
Hold Register (Word Device)	GMW22528 to GMW23551	MW22528+ offset to MW23551+ offset	1024 Words	
	GMW23552 to GMW24575	MW23552+ offset to MW24575+ offset	1024 Words	
	GMW24576 to GMW25599	MW24576+ offset to MW25599+ offset	1024 Words	
	GMW25600 to GMW26623	MW25600+ offset to MW26623+ offset	1024 Words	
	GMW26624 to GMW27647	MW26624+ offset to MW27647+ offset	1024 Words	
	GMW24648 to GMW28671	MW24648+ offset to MW28671+ offset	1024 Words	
	GMW28672 to GMW29695	MW28672+ offset to MW29695+ offset	1024 Words	
	GMW29696 to GMW30719	MW29696+ offset to MW30719+ offset	1024 Words	
	GMW30720 to GMW31743	MW30720+ offset to MW31743+ offset	1024 Words	
	GMW31744 to GMW32767	MW31744+ offset to MW32767+ offset	1024 Words	
	GMW32768 to GMW33791	MW32768+ offset to MW33791+ offset	1024 Words	
	GMW33792 to GMW34815	MW33792+ offset to MW34815+ offset	1024 Words	
	GMW34816 to GMW35839	MW34816+ offset to MW35839+ offset	1024 Words	
	GMW35840 to GMW36863	MW35840+ offset to MW36863+ offset	1024 Words	
	GMW36864 to GMW37887	MW36864+ offset to MW37887+ offset	1024 Words	
	GMW37888 to GMW38911	MW37888+ offset to MW38911+ offset	1024 Words	
	GMW38912 to GMW39935	MW38912+ offset to MW39935+ offset	1024 Words	
	GMW39936 to GMW40959	MW39936+ offset to MW40959+ offset	1024 Words	
	GMW40960 to GMW41983	MW40960+ offset to MW41983+ offset	1024 Words	
	GMW41984 to GMW43007	MW41984+ offset to MW43007+ offset	1024 Words	
GMW43008 to GMW44031	MW43008+ offset to MW44031+ offset	1024 Words		
GMW44032 to GMW45055	MW44032+ offset to MW45055+ offset	1024 Words		
GMW45056 to GMW46079	MW45056+ offset to MW46079+ offset	1024 Words		

L/H

(Continued on following page.)

■ **MP2300 Series** (Continued from previous page)





















Device	GP Device Address	MP2300 Devices	No. of Devices	Remarks
Hold Register (Word Device)	GMW46080 to GMW47103	MW46080 + offset to MW47103 + offset	1024 Words	
	GMW47104 to GMW48127	MW47104 + offset to MW48127 + offset	1024 Words	
	GMW48128 to GMW49151	MW48128 + offset to MW49151 + offset	1024 Words	
	GMW49152 to GMW50175	MW49152 + offset to MW50175 + offset	1024 Words	
	GMW50176 to GMW51199	MW50176 + offset to MW51199 + offset	1024 Words	
	GMW51200 to GMW52223	MW51200 + offset to MW52223 + offset	1024 Words	
	GMW52224 to GMW53247	MW52224 + offset to MW53247 + offset	1024 Words	
	GMW53248 to GMW54271	MW53248 + offset to MW54271 + offset	1024 Words	
	GMW54272 to GMW55295	MW54272 + offset to MW55295 + offset	1024 Words	
	GMW55296 to GMW56319	MW55296 + offset to MW56319 + offset	1024 Words	
	GMW56320 to GMW57343	MW56320 + offset to MW57343 + offset	1024 Words	
	GMW57344 to GMW58367	MW57344 + offset to MW58367 + offset	1024 Words	
	GMW58368 to GMW59391	MW58368 + offset to MW59391 + offset	1024 Words	
	GMW59392 to GMW60415	MW59392 + offset to MW60415 + offset	1024 Words	
	GMW60416 to GMW61439	MW60416 + offset to MW61439 + offset	1024 Words	
	GMW61440 to GMW62463	MW61440 + offset to MW62463 + offset	1024 Words	
	GMW62464 to GMW63487	MW62464 + offset to MW63487 + offset	1024 Words	
	GMW63488 to GMW64511	MW63488 + offset to MW64511 + offset	1024 Words	
GMW64512 to GMW65534	MW64512 + offset to MW65534 + offset	1023 Words		
Input Register (Word Device) *1	GIW0000 to GIW03FF	IW0000 + offset to IW03FF + offset	1024 Words	
	GIW0400 to GIW07FF	IW0400 + offset to IW07FF + offset	1024 Words	
	GIW0800 to GIW0BFF	IW0800 + offset to IW0BFF + offset	1024 Words	
	GIW0C00 to GIW0FFF	IW0C00 + offset to IW0FFF + offset	1024 Words	
	GIW1000 to GIW13FF	IW1000 + offset to IW13FF + offset	1024 Words	

L/H

(Continued on following page.)

\*1 Can be read out from a GP, however cannot be written to a GP. When data write is attempted to a GP, a "Receive Data Error" (02:FC:\*\*\*) will be displayed. (\*\*\*) is the GP unit number.)

■ **MP2300 Series** (Continued from previous page)

Device	GP Device Address	MP2300 Devices	No. of Devices	Remarks
Input Register (Word Device) *1	GIW1400 to GIW17FF	IW1400+ offset to IW17FF+ offset	1024 Words	
	GIW1800 to GIW1BF	IW1800+ offset to IW1BFF+ offset	1024 Words	
	GIW1C800 to GIW1FFF	IW1C00+ offset to IW1FFF+ offset	1024 Words	
	GIW2000 to GIW23FF	IW2000+ offset to IW23FF+ offset	1024 Words	
	GIW2400 to GIW27FF	IW2400+ offset to IW27FF+ offset	1024 Words	
	GIW2800 to GIW2BFF	IW2800+ offset to IW2BFF+ offset	1024 Words	
	GIW2C00 toGIW2FFF	IW2C00+ offset to IW2FFF+ offset	1024 Words	
	GIW3000 to GIW33FF	IW3000+ offset to IW33FF+ offset	1024 Words	
	GIW3400 to GIW37FF	IW3400+ offset to IW37FF+ offset	1024 Words	
	GIW3800 to GIW3BFF	IW3800+ offset to IW3BFF+ offset	1024 Words	
	GIW3C00 toGIW3FFF	IW3C00+ offset to IW3FFF+ offset	1024 Words	
	GIW4000 to GIW43FF	IW4000+ offset to IW43FF+ offset	1024 Words	
	GIW4400 to GIW47FF	IW4400+ offset to IW47FF+ offset	1024 Words	
	GIW4800 to GIW4BFF	IW4800+ offset to IW4BFF+ offset	1024 Words	
	GIW4C00 toGIW4FFF	IW4C00+ offset to IW4FFF+ offset	1024 Words	
	GIW5000 to GIW53FF	IW5000+ offset to IW53FF+ offset	1024 Words	
	GIW5400 to GIW57FF	IW5400+ offset to IW57FF+ offset	1024 Words	
	GIW5800 to GIW5BFF	IW5800+ offset to IW5BFF+ offset	1024 Words	
	GIW5C00 toGIW5FFF	IW5C00+ offset to IW5FFF+ offset	1024 Words	
	GIW6000 to GIW63FF	IW6000+ offset to IW63FF+ offset	1024 Words	
GIW6400 to GIW67FF	IW6400+ offset to IW67FF+ offset	1024 Words		

L/H

(Continued on following page.)

\*1 Can be read out from a GP, however cannot be written to a GP. When data write is attempted to a GP, a "Receive Data Error" (02:FC:\*\*\*) will be displayed. (\*\*\*) is the GP unit number.)

## ■ MP2300 Series (Continued from previous page)

Device	GP Device Address	MP2300 Devices	No. of Devices	Remarks
Input Register (Word Device) *1	GIW6800 toGIW6BFF	IW6800+ offset to IW6BFF+ offset	1024 Words	L/H 
	GIW6C00 toGIW6FFF	IW6C00+ offset to IW6FFF+ offset	1024 Words	
	GIW7000 toGIW73FF	IW7000+ offset to IW73FF+ offset	1024 Words	
	GIW7400 toGIW77FF	IW7400+ offset to IW77FF+ offset	1024 Words	
	GIW7800 toGIW7BFF	IW7800+ offset to IW7BFF+ offset	1024 Words	
	GIW7C00 toGIW7FFF	IW7C00+ offset to IW7FFF+ offset	1024 Words	

\*1 Can be read out from a GP, however cannot be written to a GP. When data write is attempted to a GP, a "Receive Data Error" (02:FC:\*\*\*) will be displayed. (\*\*\*) is the GP unit number.)



- When using the MP2300 unit, be sure to use the following settings for the PLC.

### ■ Communication via [Auto Receive: Designated]

Be sure the PLC unit's [Slave I/F Register Settings] match the GP unit's address range. If the values used are less than the GP unit's address range, a Host Communication Error (02:02:\*\*) will occur. (\*\* is the Unit number.) The following table shows the maximum usable GP address range setting values.

#### GP unit maximum address range setting values:

Slave Unit I/F Register Settings	Start REG	No. of Words
Input Relay Readout	IW0000	4096
Input Register Readout	IW0000	32768
Coil Read/Write	MW00000	4096
Hold Register Read/Write	MW00000	65535
Coil/Hold Register Write Range	LO:	MW00000
	HI:	MW65534

(Continued on following page.)



(Continued from previous page)

- **When using the MP2300, be sure to set the GP unit's address range settings so they match the PLC unit's [Slave Unit I/F Register Settings]. If the address range(s) set for the PLC are smaller than the range(s) set for the GP, a Host Communication error (02:02:\*\*) will occur. The table below shows the GP unit's maximum address range settings.**

Slave Unit I/F Register Settings	Start REG	No. of Words
Input Relay Read-in	IW0000	4096
Input Register Read-in	IW0000	32768
Coil Read/Write	MW00000	4096
Hold Register Read/Write	MW00000	65535
Coil/Hold Register Write Range	LO:	MW00000
	HI:	MW65534



- **Designate the LS area bit at the end of the Word Address, using from 0 to F.**
- **Since the Yaskawa Electric MP2000/MP900/CP-9200SH unit's protocol can be used for a 1:n connection, it will differ from the MEMOCON-SC's protocol and internal method of representing devices. When you wish to modify the screen data from a MEMOCON-SC, you will need to reenter device data.**
- **The hold Register and Input Register device settings must be entered within each block. Any settings that extend into other blocks are not allowed.**  
(Example: You cannot enter a 20 word long setting, starting from GMW1010.)



When you are setting up parts and tags in GP-PRO/PB III, you can designate PLC's station numbers as you are inputting addresses. If you do not designate the station numbers, the number following the one you previously entered will be automatically selected. (The factory setting is "1".)

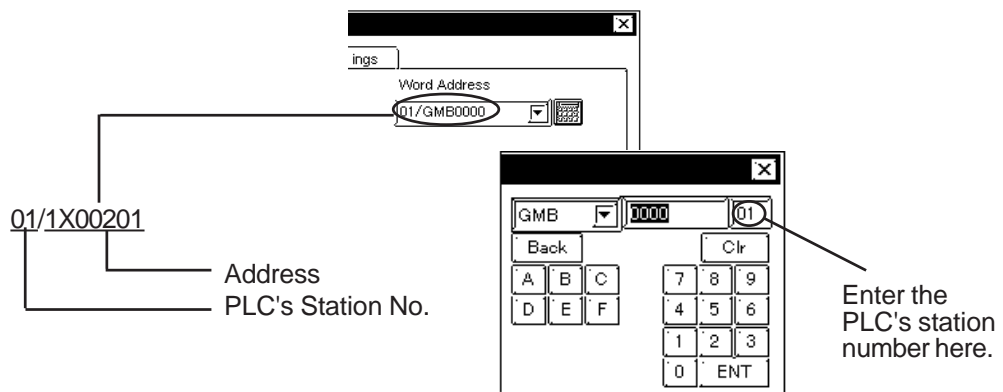

## 2.4.4 Environment Setup

The following lists Digital's recommended PLC and GP communication settings.

### ■ Memocon-SC Series

(GL40S/GL60S/GL60H/GL70H) (GL120CPU Direct Connection)

GP Setup		Communication Module Setup	
Baud Rate	19200 bps	Baud Rate	19200 bps
Data Length	8 bits (fixed)	Transfer Mode	RTU Mode (fixed)
Stop Bit	1 bit	Stop Bit	1 bit
Parity Bit	Even	Parity On/Off EVEN/ODD	ON EVEN
Data Flow Control	ER Control	---	
Communication Format	RS-232C	---	
---		Delay Count <sup>*1</sup>	0
Unit No.	1	Station Number Setting	1

\* 1 There is no Delay Count for the JAMSC-IF60 SIO Module.

### ■ Memocon-SC Series (U84/U84J/U84S)

GP Setup		Communication Module Setup	
Baud Rate	19200 bps	Baud Rate	19200 bps
Data Length	8 bits	Transfer Mode	RTU Mode
Stop Bit	1 bit	Stop Bit	1 bit
Parity Bit	Even	Parity Bit	EVEN
Data Flow Control	ER Control	---	
Communication Format	RS-232C	---	
---		Port Delay Timer	0
Unit No.	1	Address	1

### ■ Memocon-SC Series (GL120/GL130)

GP Setup		Communication Module Setup	
Baud Rate	19200 bps	Baud Rate	19200 bps
Data Length	8 bits		
Stop Bit	1 bit	Stop Bit	1 bit
Parity Bit	Even	ON/OFF	ON
Data Flow Control	ER Control	Even/ODD	Even
Communication Format	RS-422	Communicationsport	RS-422
---		Slave address No.	1
Unit No.	1	Communications bit	RTU mode (fixed)

■ **PROGIC-8**

GP Setup		Port 1/Port 2 Setup	
Baud Rate (for Port 1 connection)	9600 bps (fixed)	---	
Baud Rate (for Port 2 connection)	19200 bps	Baud Rate (for Port 2 connection)	19200 bps
Data Length	8 bits	---	
Stop Bit	1 bit	---	
Parity Bit	Even	---	
Data Flow Control	ER Control	---	
Communication Format	RS-232C	---	
Unit No.	1	---	

■ **Control Pack Series**

GP Setup		Machine Controller 4CN/6CN Setup	
Baud Rate	9600 bps	Baud Rate	9600 bps
Data Length	8 bits	Data Bit	8 bits
Stop Bit	1 bit	Stop Bit	1 bit
Parity Bit	Even	Parity Bit	Even
Data Flow Control	ER Control	---	
Communication Format	RS-232C	---	
Unit No.	1	Station Number Setting	1

■ **Memocon Micro**

GP Setup		Comm1 Port Setup	
Baud Rate	9600 bps	Baud Rate	9600 bps
Data Length	8 bits	Data Bit	8 bits
Stop Bit	1 bit	Stop Bit	1 bit
Parity Bit	Even	Parity Bit	Even
Data Flow Control	ER Control	---	
Communication Format	RS-232C	---	
Unit No.	1	Station Number Setting	1

## ■ Control Pack Series for CP-9200SH

	GP Setup	PLC Setup
Baud rate	9600bps	9600bps
Data Length	8	8
Stop Bit	1	1
Parity Bit	Even	Even
Data Flow Control	ER Control	ER Control
Communication Format (RS-232C)	RS-232C	CN1 or CN2
(RS-422)	4 Wire-Type	CN3
System Area Start Address	GMW0000	-----
Station No.	1 ~ 32	1 ~ 32



- When connecting the GP77R Series unit to the "\*\*\*\*\*-21700-\*\*\*\*\*" or older version of 217IF unit, select the "GP Settings" menu's "Communication Settings" tab in 3.0 or later version of GP-PRO/PB III for Windows screen creation software, and click on the "Advanced" field, and then designate "20ms" for the "Send Wait" setting.
- A ladder program is needed when connecting the GP to a Yaskawa CP-217IF link I/F unit.
- Be aware that this sample program enables the GP to communicate with only one CN unit, and when you wish to use more than one CN unit (CN1 to CN3) at the same time you will need to create a ladder program for each CN.
- The PLC's communication settings cannot be entered by this program. You will need to enter these settings via the ladder software.

## ■ Control Pack Series CP-9200SH Sample program

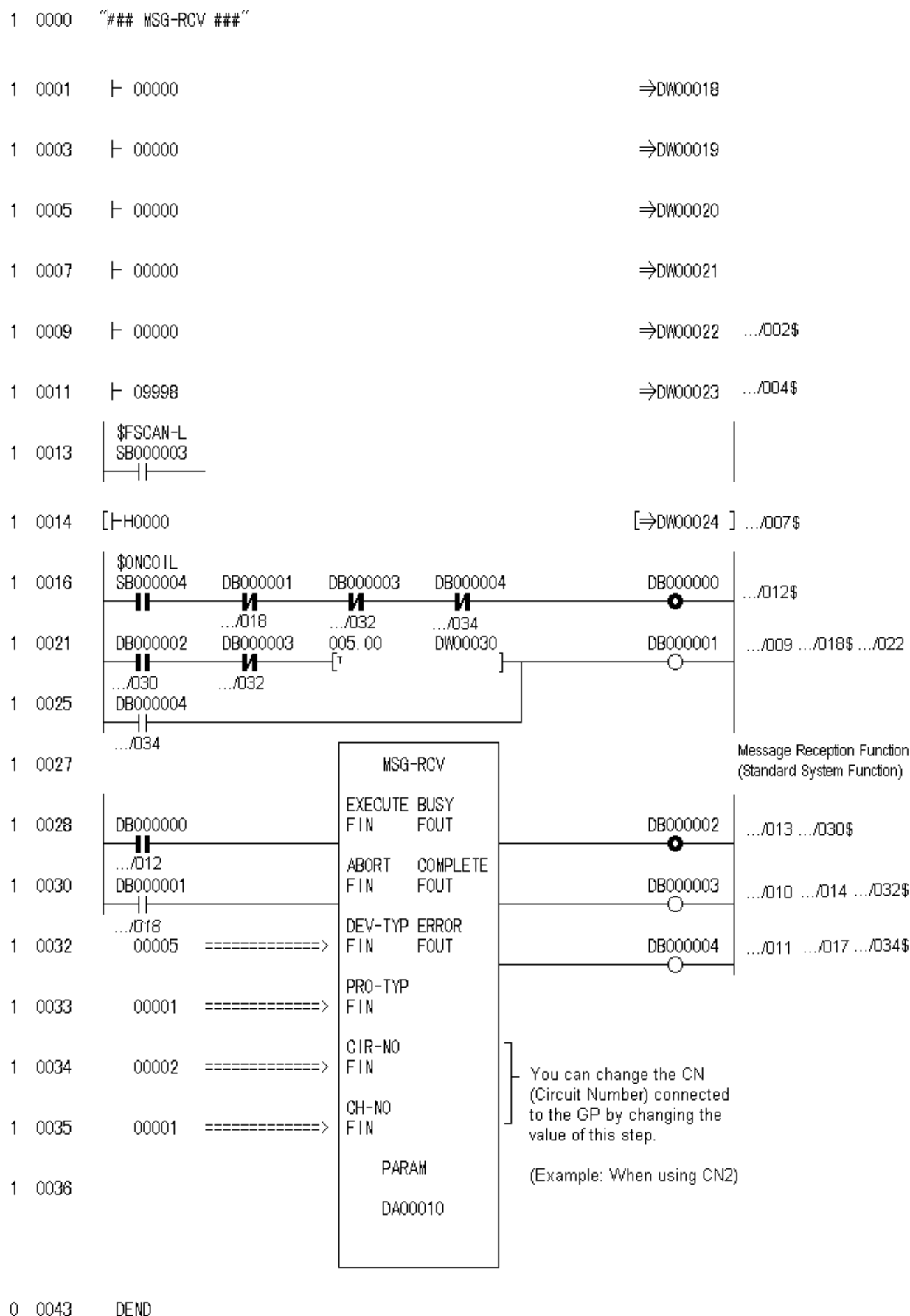

## ■ MP900 Series

GP Setup		PLC Setup	
Baud rate	19200bps	Baud rate	19.2Kbps
Data Length	8	Data Length	8
Stop Bit	1	Stop Bit	1
Parity Bit	Even	Parity Bit	Even
Data Flow Control	ER Control	Send Mode	RTU
Communication Format (RS-232C)	RS-232C	Serial I/F (RS-232C)	RS-232C
Communication Format (RS-422)	4 Wire-Type	Serial I/F (RS-422)	RS-485
Unit No.	1	Device Address	01
	——	Master Slave	Slave
	——	Transmission Protocol	MEMOBUS



### Note:

- A ladder program is needed when connecting the GP Series unit to a Yaskawa Electric corporation CP-217IF link I/F unit's CN1,CN2,CN3 or to MEMOBUS Ports (Port 1 or Port 2).
- Be aware that this sample program enables the GP to communicate with only one CN unit, and when you wish to use more than one CN unit at the same time you will need to create a ladder program for each CN.
- The PLC's communication settings cannot be entered by this program. You will need to enter these settings via the ladder software.

## ■ MP900 Series Sample program

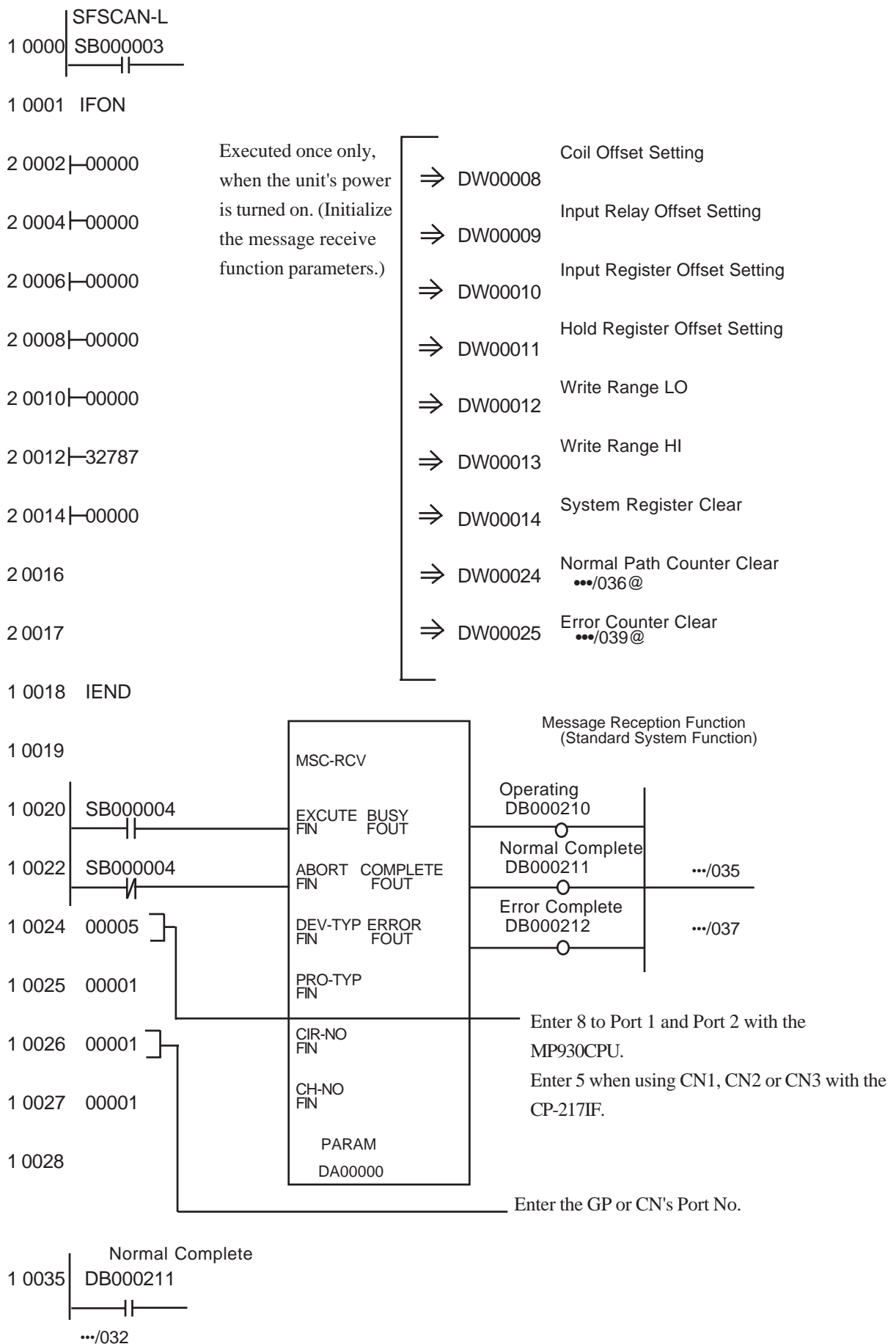

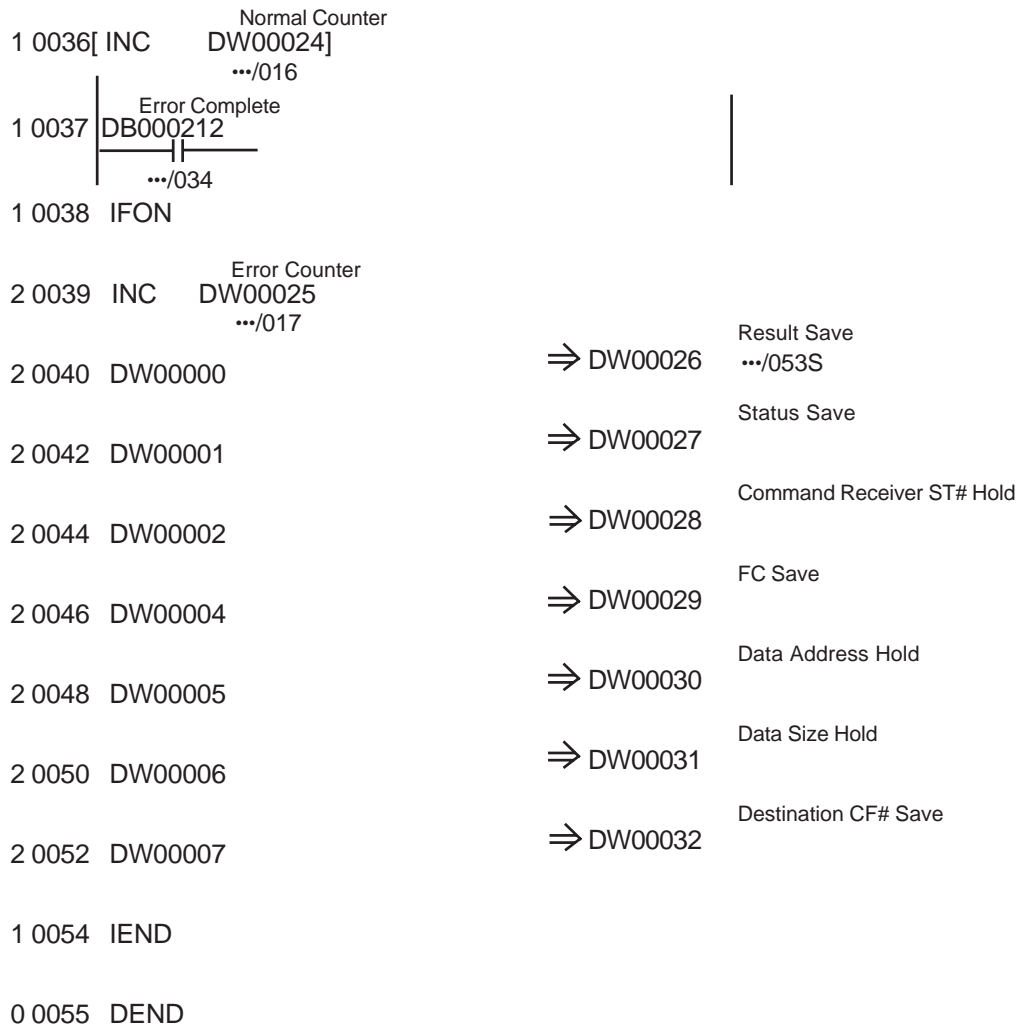



## ■ MP2300 Series

GP Setup		PLC Setup	
Baud Rate (bps)	19200	Baud Rate (bps)	19200
Data Length	8 bits	Data Length	8 bits
Stop Bit	1 bit	Stop Bit	1 bit
Parity Bit	Even	Parity Bit	Even
Data Flow Control	ER Control	——	
Communication Format	RS-232C	Serial I/F	RS-232C
	RS-422 (4-Wire)		RS-422/485
Unit No.	1 to 32	Device Address	1 to 32
——		Transmission Protocol	MEMOBUS
——		Master/Slave	Slave
——		Transmission Mode	RTU
——		Send Delay	Not designated
——		Auto Receive *1	Designated
——			Not designated

\*1 When a connection is made with [Auto Receive] set to [Not designated], a ladder program is required for communication between the GP and the PLC. (See next page) When [Designated] is used, a ladder program is not required. The sample program included here is for connecting the GP and a connector. When the 217IF-01 unit's RS-232C connector, RS422 connector and the 218IF-01 unit's RS-232C connector are used at the same time, be aware that a ladder program will be required for each connector.

## ■ MP2300 Series Sample Program

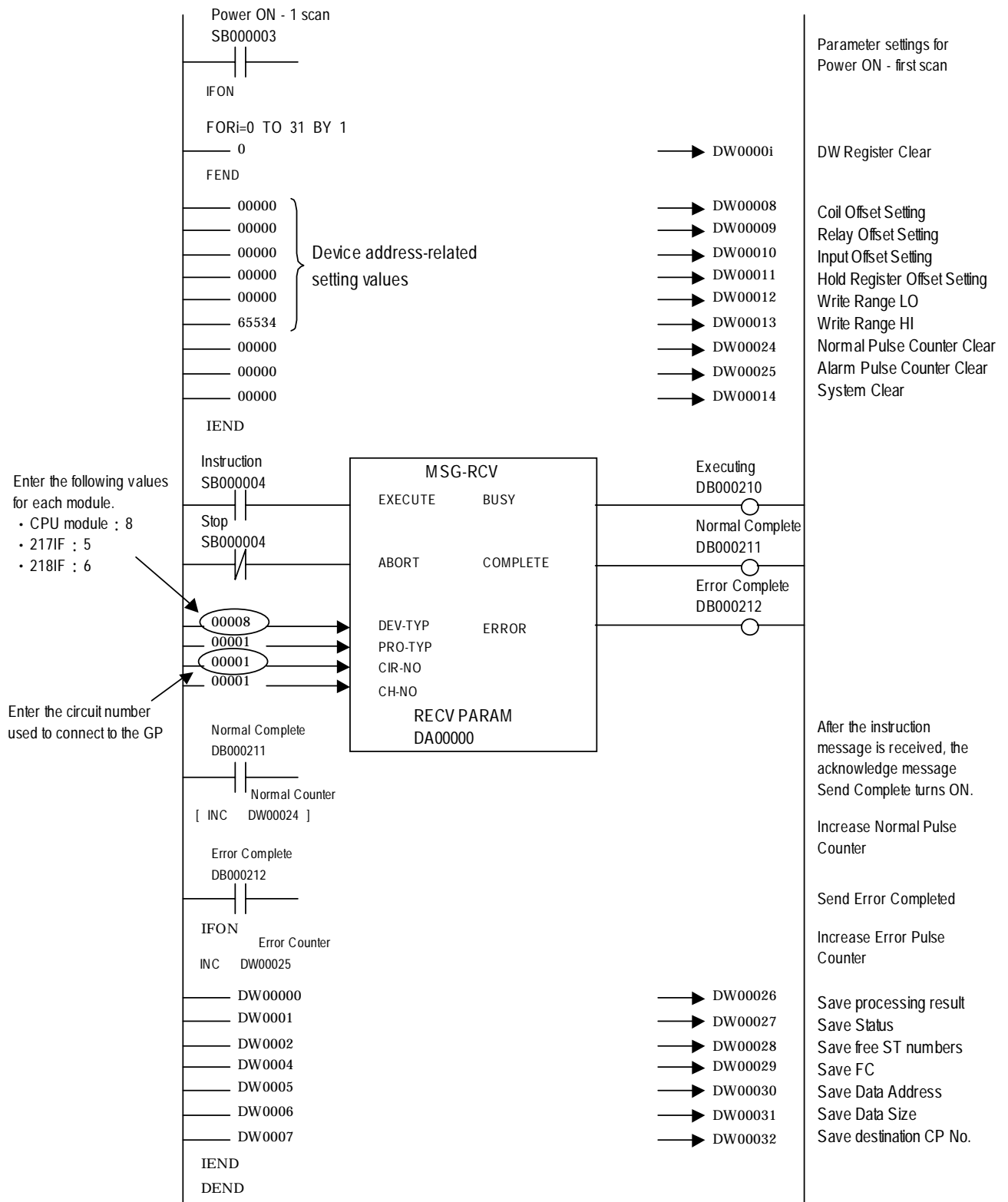

# A Yasukawa Electric

## A.1 Maximum Number of Consecutive Device Address

The following lists the maximum number of consecutive addresses that can be read by each PLC. Refer to these tables to utilize *Block Transfer*.



**Note:** When the device is setup using the methods below, the Data Communication Speed declines by the number of times the device is read.

- When consecutive addresses exceed the maximum data number range
- When an address is designated for *division*
- When device types are different

To speed up data communication, plan the tag layout in screen units, as consecutive devices. (Includes the Alarm and Trend screens.)

### ■ PLC

<Memocon-SC Series (includes Micro)>

Device	Max. No. of Consecutive Address
Coil (Output/Internal)	250 Words
Input Relay	
Link Coil D	128 Words
Input Register	125 Words
Output/Latch Register	
Link Register R	
Constant Register	
Extended Register	

<PROGIC-8 Series>

Device	Max. No. of Consecutive Address
Output Coil O	250 Words
Input Relay I	
Internal Coil N	
Link Coil D	128 Words
Data Register W	125 Words
Input Register D	
Link Register R	

<MP900/ CP-9200SH Series>

Device	Max. No. of Consecutive Address
Output Coil	125 Words
Input Relay	
Special Latch Register	
Input Register	

<Control Pack Series>

Device	Max. No. of consecutive Address
Input Coil O	250 Words
Output Register	
System Register	
System Register	125 Words
Data Register	
Common Register	
Input Register	
Output Register	

<MP2300 Series>

Device	Max. No. of Consecutive Addresses
Coil	125 Words
Input Relay	
Special Latch Register	
Input Register	

■ Inverter

Device	Max. No. of Consecutive Addresses
Bit Register	16 Words
Register	

**A.2****Device Codes and Address Codes**

Device codes and address codes are used to specify indirect addresses for the E-tags or K-tags.

The word addresses of data to be displayed are coded and stored in the word address specified by the E-tags and K-tags. (Code storage is done either by the PLC, or with T-tag and K-tags)

**■ PLC**

<Memocon-SC Series (U84/84J/U84S/GL40S/GL60H/GL70H/GL60S)>

	Device	Word Address	Device code (HEX)	Address code
Word Device	Input Register	30001-	1240	Save as word address value minus 30001.
	Output/Keep Register	40001-	0040	Save as word address value minus 40001.
	Link Register	R0001-	4840	Save as word address value minus 1.
	Constant Register	31001-	1440	Save as word address value minus 31001.
	Extended Register	A0000-	1040	Word Address
	LS area	LS0000-	4040	Word Address

<Memocon-SC Series (GL120/GL130)>

	Device	Word Address	Device code (HEX)	Address code
Word Device	Input Register	300001-	1240	Save as word address value minus 30001.
	Output Register	400001-	0040	Save as word address value minus 40001.
	Keep Register	400513-	0040	Save as word address value minus 40001.
	Constant Register	700001-	X	X
	LS area	LS0000-	4040	Word Address

<PROGIC-8 Series>

	Device	Word Address	Device code (HEX)	Address code
Word Device	Data Register	W1~	0040	Save as word address value minus 1.
	Input Register	Z1~	1240	Save as word address value minus 1.
	Link Register	R1~	4840	Save as word address value minus 1.
	LS area	LS0000~	4040	Word Address

<Control Pack Series>

	Device	Word Address	Device code (HEX)	Address code	
Word Device	Input Register	49744~	0040	Save as word address value minus 40001.	
	Output Register	49872~	0040	Save as word address value minus 40001.	
	System Register	30001~	1240	Save as word address value minus 30001.	
	Data Register		31001~ (C/P-9200H only)	1440	Save as word address value minus 3101.
			40001~	0040	Save as word address value minus 40001.
	Common Register	42049~	0040	Save as word address value minus 40001.	
	LS area	LS0000~	4040	Word Address	

<Memocon Micro>

	Device	Word Address	Device code (HEX)	Address code
Word Device	Input Register	30001~	1240	Save as word address value minus 30001.
	Output/Keep Register	40001~	0040	Save as word address value minus 40001.
	LS area	LS0000~	4040	Word Address

<MP900/CP200SH Series>

	DEVICE	WORD ADDRESS	DEVICE CODE (HEX)	ADDRESS CODE
Word Addresses	COIL	GMB0000-	0x9000	Word Address value
	INPUT RELAY	GIB0000 -	0x8000	Word Address value
	HOLD REGISTER	GMW0000 -	0x0200	Word Address value
	HOLD REGISTER	GMW1024 -	0x0400	Word Address -1024 value
	HOLD REGISTER	GMW2048 -	0x0600	Word Address -2048 value
	HOLD REGISTER	GMW3072 -	0x0800	Word Address -3072 value
	HOLD REGISTER	GMW4096 -	0x0A00	Word Address -4096 value
	HOLD REGISTER	GMW5120 -	0x0C00	Word Address -5120 value
	HOLD REGISTER	GMW6144 -	0x0E00	Word Address -6144 value
	HOLD REGISTER	GMW7168 -	0x1000	Word Address -7168 value
	HOLD REGISTER	GMW8192 -	0x1200	Word Address -8192 value
	HOLD REGISTER	GMW9216 -	0x1400	Word Address -9216 value
	INPUT REGISTER	GIW0000 -	0x2000	Word Address value
	INPUT REGISTER	GIW0400 -	0x2200	Word Address -1024 value
	INPUT REGISTER	GIW0800 -	0x2400	Word Address -2048 value
	INPUT REGISTER	GIW0C00 -	0x2600	Word Address -3072 value
	INPUT REGISTER	GIW1000 -	0x2800	Word Address -4096 value
	LS	0 -	0x4000	Word Address

<MP2300 Series>

Device	Word Address	Device Address	Address Code
Coil	GMB0000 -	0x9000	Word Address
	GMB1024 -	0x9200	Word Address - 1024
	GMB2048 -	0x9400	Word Address - 2048
	GMB3072 -	0x9600	Word Address - 3072
Input Relay	GIB0000 -	0x8000	Word Address
	GIB0400 -	0x9800	Word Address - 1024
	GIB0800 -	0x9A00	Word Address - 2048
	GIB0C00 -	0x9C00	Word Address - 3072
Special Latch Register	GMW00000 -	0x0200	Word Address
	GMW01024 -	0x0400	Word Address - 1024
	GMW02048 -	0x0600	Word Address - 2048
	GMW03072 -	0x0800	Word Address - 3072
	GMW04096 -	0x0A00	Word Address - 4096
	GMW05120 -	0x0C00	Word Address - 5120
	GMW06144 -	0x0E00	Word Address - 6144
	GMW07168 -	0x1000	Word Address - 7168
	GMW08192 -	0x1200	Word Address - 8192
	GMW09216 -	0x1400	Word Address - 9216
	GMW10240 -	0x1600	Word Address - 10240
	GMW11264 -	0x1800	Word Address - 11264
	GMW12288 -	0x1A00	Word Address - 12288
	GMW13312 -	0x1C00	Word Address - 13312
	GMW14336 -	0x1E00	Word Address - 14336
	GMW15360 -	0x2A00	Word Address - 15360
	GMW16384 -	0x2C00	Word Address - 16384
	GMW17408 -	0x2E00	Word Address - 17408
	GMW18432 -	0x3000	Word Address - 18432
	GMW19456 -	0x3200	Word Address - 19456
	GMW20480 -	0x3400	Word Address - 20480
	GMW21504 -	0x3600	Word Address - 21504
	GMW22528 -	0x3800	Word Address - 22528
	GMW23552 -	0x3A00	Word Address - 23552
	GMW24576 -	0x3C00	Word Address - 24576
	GMW25600 -	0x3E00	Word Address - 25600
	GMW26624 -	0x4200	Word Address - 26624
	GMW24648 -	0x4400	Word Address - 27648
GMW28672 -	0x4600	Word Address - 28672	

(Continued on following page.)



## &lt;MP2300 Series&gt; (Continued from previous page)

Device	Word Address	Device Address	Address Code
Special Latch Register	GMW29696 -	0x4800	Word Address - 29696
	GMW30720 -	0x4A00	Word Address - 30720
	GMW31744 -	0x4C00	Word Address - 31744
	GMW32768 -	0x4E00	Word Address - 32768
	GMW33792 -	0x5000	Word Address - 33792
	GMW34816 -	0x5200	Word Address - 34816
	GMW35840 -	0x5400	Word Address - 35840
	GMW36864 -	0x5600	Word Address - 36864
	GMW37888 -	0x5800	Word Address - 37888
	GMW38912 -	0x5A00	Word Address - 38912
	GMW39936 -	0x5C00	Word Address - 39936
	GMW40960 -	0x5E00	Word Address - 40960
	GMW41984 -	0x6000	Word Address - 41984
	GMW43008 -	0x6200	Word Address - 43008
	GMW44032 -	0x6400	Word Address - 44032
	GMW45056 -	0x6600	Word Address - 45056
	GMW46080 -	0x6800	Word Address - 46080
	GMW47104 -	0x6A00	Word Address - 47104
	GMW48128 -	0x6C00	Word Address - 48128
	GMW49152 -	0x6E00	Word Address - 49152
	GMW50176 -	0x7000	Word Address - 50176
	GMW51200 -	0x7200	Word Address - 51200
	GMW52224 -	0x7400	Word Address - 52224
	GMW53248 -	0x7600	Word Address - 53248
	GMW54272 -	0x7800	Word Address - 54272
	GMW55296 -	0x7A00	Word Address - 55296
	GMW56320 -	0x7C00	Word Address - 56320
	GMW57344 -	0x7E00	Word Address - 57344
	GMW58368 -	0x8200	Word Address - 58368
	GMW59392 -	0x8400	Word Address - 59392
	GMW60416 -	0x8600	Word Address - 60416
	GMW61440 -	0x8800	Word Address - 61440
	GMW62464 -	0x8A00	Word Address - 62464
	GMW63488 -	0x8C00	Word Address - 63488
GMW64512 -	0x8E00	Word Address - 64512	

(Continued on following page.)

<MP2300 Series> (Continued from previous page)

Device	Word Address	Device Address	Address Code
Input Register	GIW0000 -	0x2000	Word Address
	GIW0400 -	0x2200	Word Address - 1024
	GIW0800 -	0x2400	Word Address - 2048
	GIW0C00 -	0x2600	Word Address - 3072
	GIW1000 -	0x2800	Word Address - 4096
	GIW1400 -	0x9E00	Word Address - 5120
	GIW1800 -	0xA000	Word Address - 6144
	GIW1C800 -	0xA200	Word Address - 7168
	GIW2000 -	0xA400	Word Address - 8192
	GIW2400 -	0xA600	Word Address - 9216
	GIW2800 -	0xA800	Word Address - 10240
	GIW2C00 -	0xAA00	Word Address - 11264
	GIW3000 -	0xAC00	Word Address - 12288
	GIW3400 -	0xAE00	Word Address - 13312
	GIW3800 -	0xB000	Word Address - 14336
	GIW3C00 -	0xB200	Word Address - 15360
	GIW4000 -	0xB400	Word Address - 16384
	GIW4400 -	0xB600	Word Address - 17408
	GIW4800 -	0xB800	Word Address - 18432
	GIW4C00 -	0xBA00	Word Address - 19456
	GIW5000 -	0xBC00	Word Address - 20480
	GIW5400 -	0xBE00	Word Address - 21504
	GIW5800 -	0xC000	Word Address - 22528
	GIW5C00 -	0xC200	Word Address - 23552
	GIW6000 -	0xC400	Word Address - 24576
	GIW6400 -	0xC600	Word Address - 25600
GIW6800 -	0xC800	Word Address - 26624	
GIW6C00 -	0xCA00	Word Address - 27648	
GIW7000 -	0xCC00	Word Address - 28672	
GIW7400 -	0xCE00	Word Address - 29696	
GIW7800 -	0xD000	Word Address - 30720	
GIW7C00 -	0xD200	Word Address - 31744	
LS Area	LS0 -	0x4000	Word Address

■ Inverter

	Device	Word Address	Device Code	Address Code
Bit Device	Bit Register	BR0000 ~ BR03FF	8200	Word Address
		BR0400 ~ BR07FF	8400	
		BR0800 ~ BR0BFF	8600	
Word Device	Register	0000 ~ 03FF	0200	
		0400 ~ 07FF	0400	
		0800 ~ 0BFF	0600	
	LS Area	LS0000 ~	4000	

### A.3 Address Conversion Table

		After Conversion				
		Coil (GMB)	Input Relay (GIB)	Special Latch Register (GMW)	Input Register (GIW)	LS
Before Conversion	Coil (GMB)	○	○	○	○	○
	Input Relay (GIB)	○	○	○	○	○
	Special Latch Register (GMW)	○	○	○	○	○
	Input Register (GIW)	○	○	○	○	○
	LS	○	○	○	○	○

○ : If Conversion Mode is "Word", both word and bit devices will be converted.  
 If Conversion Mode is "Bit", only bit devices will be converted.