

GP-PRO/PBIII for Windows
Device/PLC CONNECTION MANUAL
ADDITIONAL MANUAL

Hioki E.E. Corporation Controller
Smart Site

Pro-face
Human Machine Interface —

Reading the GP-PRO/PBIII Device/PLC Connection Manual

This document is designed as an addition to the latest GP-PRO/PBIII for Windows Device/PLC Connection manual's Hioki E.E. Corporation data.

When connecting a Factory Gateway unit, please substitute the words "Factory Gateway" for this document's "GP/GLC".

Installation

This CD-ROM includes all the protocol files required by the GP/GLC to communicate with a Hioki E.E. Corporation Smart Site Series PLCs. Also, you will need to have one or more of the following software applications installed. The screen and data transfer files included in the CD-ROM must be installed in each of those applications. For information regarding installing the software, refer to that software's Operation Manual.

■ Software Applications

- GP-PRO/PBIII C-Package03 or higher.
- Pro-Server with Pro-Studio for Windows Ver. 4.1 ^{*1}

- 1) Be sure to confirm that the required software application is installed in your PC prior to starting installation.
- 2) Double-click the CD-ROM's "SMART_E.exe" file to start the installation process.
- 3) Once the installation program starts, follow the instructions given to install the protocol files.



- ***When using GP-PRO/PBIII for Windows, be sure to select [Device/PLC Type] - [others] - [Hioki SmartSite(MODBUS TCP)].***

**1 When using the Factory Gateway unit, GP-Web Ver. 1.0 or later or GP-Viewer Ver. 1.0 or later, be sure to select "Pro-Server with Pro-Studio for Windows" as the "Destination Folder".*

Hioki E.E. Corporation Controller Smart Site





When transferring Screen Data:

With this protocol, even if the transfer setting “Do not perform setup” is selected, network information settings will be transferred. As a result, after transferring the same project data to multiple GP units, be sure to check each GP unit’s network information.

1 Ethernet System Design

This section explains the system design for the Ethernet connection between Hioki E.E. Corporation controllers and GP/GLC units.

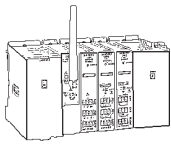
■ Smart Site Series

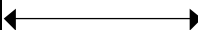
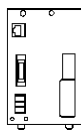
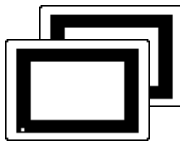
CPU	Link I/F	Cables	Optional Ethernet I/F Unit	Target Machine
				
2301 2302 2303 2304 2305 2331 2332 2341 2342 2343	2353 *1	Ethernet Cable conforming to IEEE802.3 standards	Made by Digital Electronics GP070-ET 41 GP377-MLTE11 GP377-MLTE41 GP070-MLTE41	GP/GLC Series*2

*1 The 2353 LAN module’s software version should be 2.0 or higher. Version information can be checked via the Smart Site Utility.

*2 For information about GP/GLC/Option unit compatibility, and if a unit is equipped with an Ethernet port, refer to the “Compatible GP/GLC Types” list.

■ **Compatible GP/GLC Types**

Series Name		Product Name	Optional Ethernet I/F Unit	Built-in Ethernet Unit
GP77R Series	GP-377R	GP-377RT	○ ^{*1} ^{*2}	X
	GP-477R	GP-477RE	○ ^{*2}	X
	GP-577R	GP-577RT	○ ^{*2}	X
		GP-577RS	○ ^{*2}	X
GP2000 Series	GP-2300	GP-2300T	X	○
		GP-2300L	X	○
		GP-2300S	X	○
	GP-2400	GP-2400T	X	○
	GP-2500	GP-2500T	○ ^{*3} ^{*4}	○
		GP-2500S	○ ^{*3} ^{*4}	○
		GP-2500L	○ ^{*3} ^{*4}	○
	GP-2501	GP-2501T	○ ^{*2} ^{*3}	X
		GP-2501S	○ ^{*2} ^{*3}	X
	GP-2600	GP-2600T	○ ^{*3} ^{*4}	○
GP-2601	GP-2601T	○ ^{*2} ^{*3}	X	
GLC2000 Series	GLC2000	GLC2400T	X	○
		GLC2300T	X	○
		GLC2300L	X	○
		GLC2600T	○ ^{*3} ^{*4}	○
Factory Gateway	Factory Gateway	----	X	○

*1 Only Multi unit can be used.

*2 The 2-Way Driver (Pro-Server, GP-Web and others) can not be used.

*3 When using an optional Ethernet I/F unit, the bus conversion unit (PSL-CONV00) is required.

*4 Using the optional Ethernet I/F Unit allows you to set up separate Class and Net No.s for 2-Way Driver applications (Pro-Server, GP-Web and others) and the PLC. When doing this, data transfer with the PLC is performed through the optional Ethernet I/F Unit.

■ Connection Structure

■ 1:1 Connection

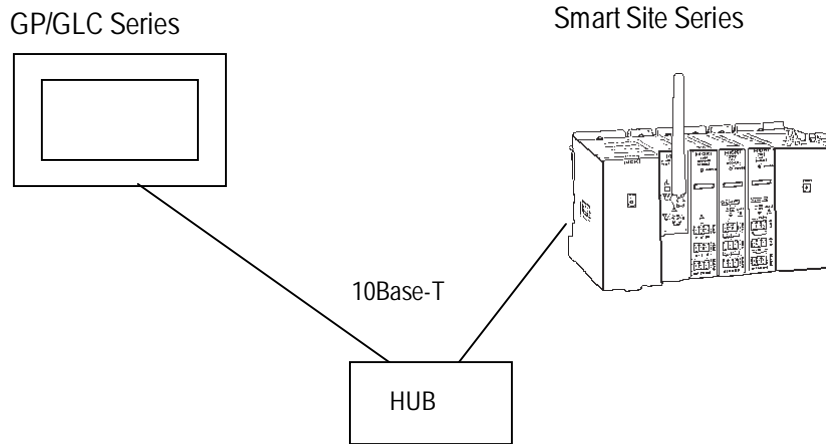

■ n:1 Connection

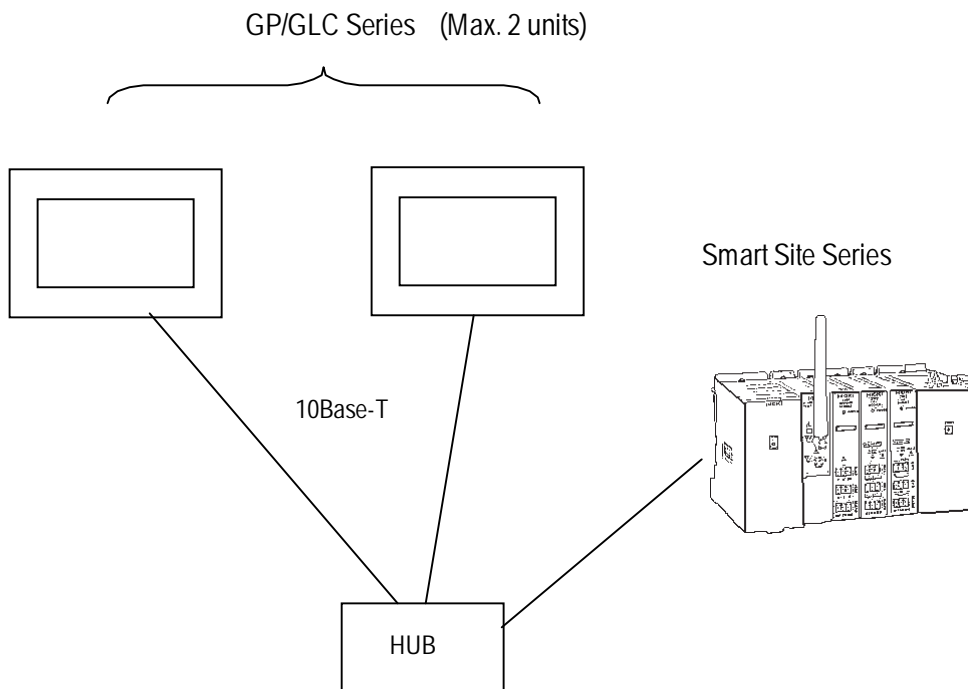

- The Max. No. of units indicated is when only GP Series units are connected. Connecting a single GP Series unit requires two connections.
- Connecting other devices via an ethernet connection will further reduce the maximum number of GP Series units that can be connected. Be sure to check the number of connections required before connecting a device. Also, since the number of usable connections vary depending on the PLC model, be sure to refer to your PLC Manual for details.

■ 1:n Connection

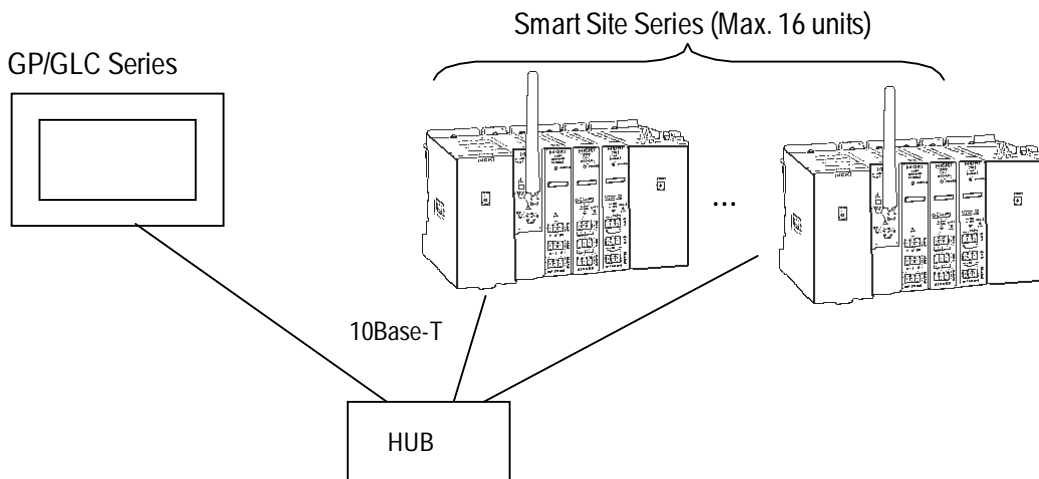

Note:

- When multiple controllers are connected, depending on system conditions, the GP unit's screen refresh time can slow. Be aware of the following points:
- <When the GP unit's screen refresh rate slows>
 - Because multiple controllers are monitored using a single screen.
 - When the addresses set for a screen's tags and parts are not continuous.
- <To improve GP screen refresh times>
 - Reduce the number of controllers monitored using a single screen.
 - Create tags and parts using continuous addresses.

■ n:m Connection

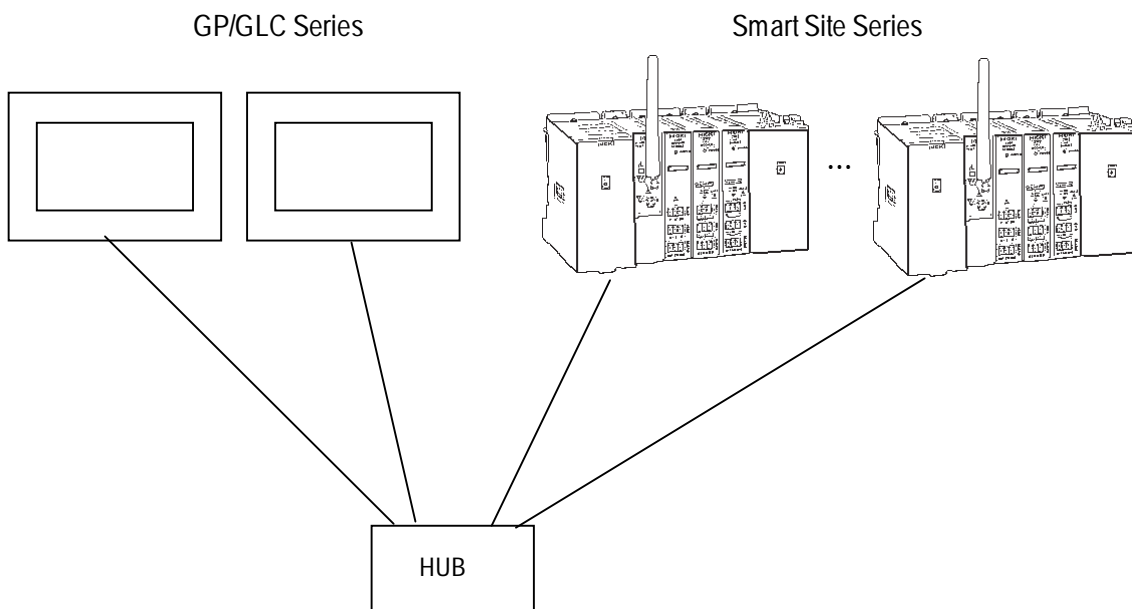

Note:

- The Max. No. of units connectable is the same for the 1:n and n:1 connections.

2 Supported Devices

The following list shows the range of devices supported by the GP/GLC.

■ Smart Site Series

Setup System Area here

Device	Bit Address	Word Address	Comment
Coils	1:000001 to 16:006399	1:000001 to 16:006385	<input style="width: 40px; height: 20px;" type="text" value="÷16+1"/>
Input Discrete	1:100001 to 16:106399	1:100001 to 16:106385	<input style="width: 40px; height: 20px;" type="text" value="÷16+1"/> *1
Input Register	—————	1:300001 to 16:306399	<input style="width: 40px; height: 20px;" type="text" value="Bit15"/> *1
Hold Register	1:40000100 to 16:46553515	1:400001 to 16:406399	L/H

*1 Data Write is not possible. When writing to this device, the “Host Communication Error (02:FB)” is displayed

• Controller addresses

Controller addresses are designated as follows:

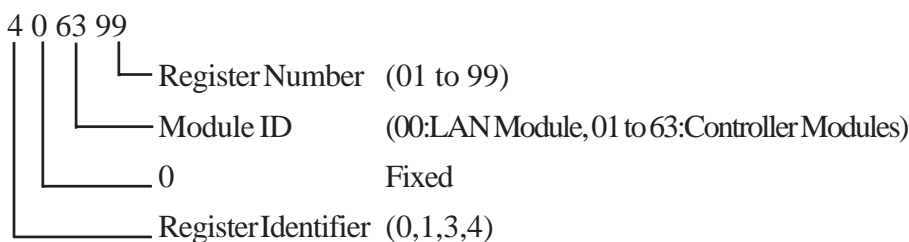

Note: Register address ranges vary depending on the module’s specifications. For details, refer to Hioki E.E. Corporation’s manuals.

• Pro Server Usage Restrictions



When accessing from Pro-Server, define in advance the symbol for the device address to be accessed. Then create the screens and import the symbols using Pro-Server. For details, refer to the Pro-Server Operation Manual.

• **When connecting multiple GP units, set up start addresses so the system areas for each GP unit do not overlap.**



: Word Addresses can only be designated using values that are multiples of 16+1.

: Bit positions are designated using 0 to 15. Also, When performing bit write using bit designations, all other undesigned bits become “0”.

L/H: When using 2 words (32 bit data), data high/low relationship is as follows.

0	Lower Posit.
1	Upper Posit.

◆ Part and Tag Settings

Prior to setting up parts and tags, Network Information settings must be entered. These settings can be found in the [GP Setup] - [Mode Settings] - [Network Info.] area.

▼ **Reference** 7.7.3 Environment Settings Example

The part or tag settings should use the destination controller's Node No. set in the Network Info. area, which will allow writing and reading of the designated controller's device.

• Designating Word Addresses

Use the following method to designate Word Addresses.

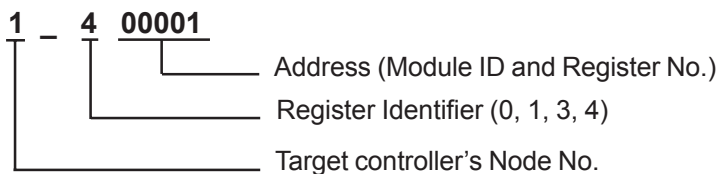
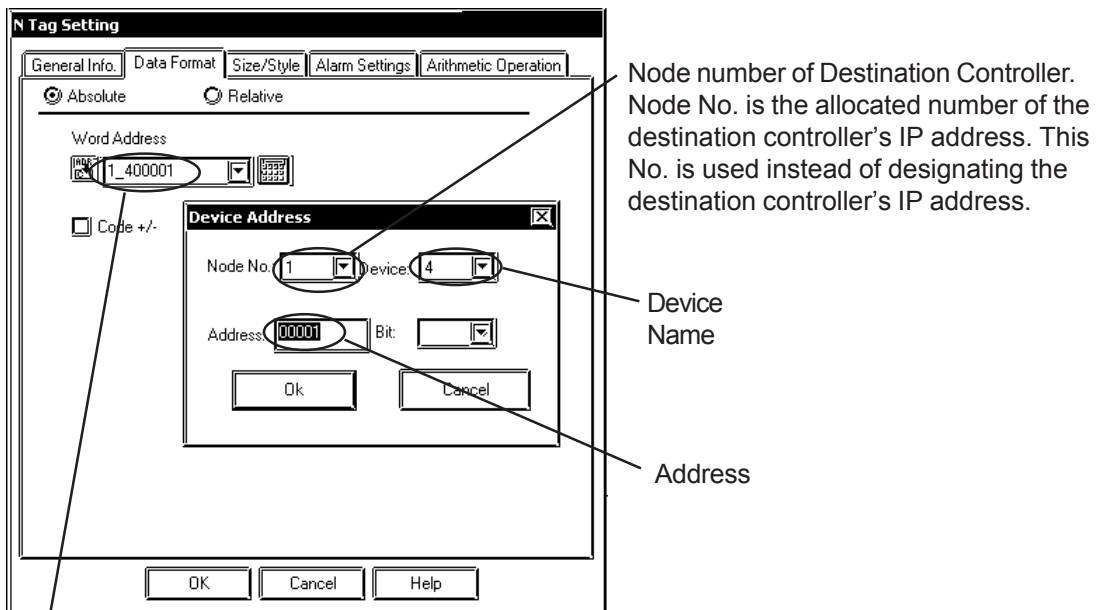

- Designating Bit Addresses

Use the following method to designate Bit Addresses.

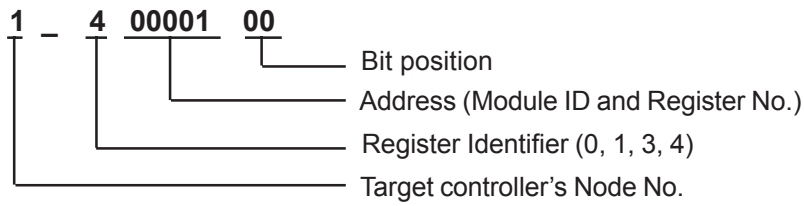
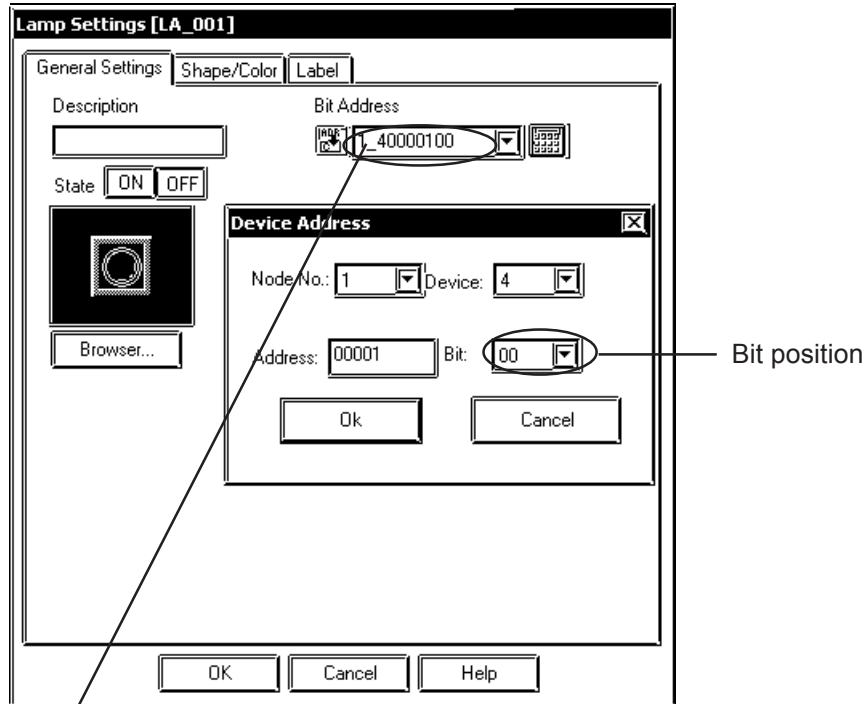

3 Environment Setup

The following table lists the recommended GP/GLC Ethernet communication settings.

GP Settings		Controller Settings ^{*2}	
SRC IP Address	GP's IP Address ^{*1}	_____	_____
Node	Controller's IP Address ^{*1}	IP Address	Controller's IP Address
Node No.	Each Controller's IP Address No.	_____	_____

**1 Contact your network administrator for setting values.*

**2 Controller settings are performed using the Hioki E.E. Corporation Smart Site Utility.*



Note:

- The communication format used is TCP (fixed).
- The controller's port number is fixed at 502.
- The GP unit can communicate using its initial setting value of 1024 (fixed), if the connection cannot be opened or is closed, when the connection is reopened, the port number is automatically increased by one (1).

■ **GP Setup Operation Surroundings Menu (OFFLINE)**

The following screens show the GP unit settings necessary for communication via ethernet connection.

SETUP OPERATION SURROUNDINGS MENU		RETURN
1	SETUP OPERATION SURROUNDINGS	
2	SETUP ETHERNET INFORMATION	
3	SETUP ETHERNET EXT. INFORMATION	

◆ **Operation Surroundings Setup (Large-sized GP)**

SETUP OPERATION SURROUNDINGS		SET	CANCEL						
SYSTEM DATA AREA START DB		[DB 1]							
START DW		[0]							
READING AREA SIZE (0-256)		[0]							
RESET GP ON DATA WRITE ERROR	ON	OFF							
<p>Note!</p> <p>The system start address cannot be changed on GP.</p> <p>Please use GP-PRO/PB3 to set this data and re-send to the GP</p>									
1	2	3	4	5	6	7	8	9	0

System Area related settings and On Data Write Error settings are performed via this menu. The system area start address cannot be changed via the GP unit. Be sure to use GP-PRO/PBIII Screen Editor software to change this data and resend it to the GP unit.

◆ Ethernet Information Settings

SETUP ETHERNET INFORMATION												SET		CANCEL																	
SRC IP ADDRESS												[]		.		[]		.		[]					
DESTINATION IP ADDRESSES (READ ONLY)																															
NODE 1:				.				.				.				NODE 9:				.				.				.			
NODE 2:				.				.				.				NODE 10:				.				.				.			
NODE 3:				.				.				.				NODE 11:				.				.				.			
NODE 4:				.				.				.				NODE 12:				.				.				.			
NODE 5:				.				.				.				NODE 13:				.				.				.			
NODE 6:				.				.				.				NODE 14:				.				.				.			
NODE 7:				.				.				.				NODE 15:				.				.				.			
NODE 8:				.				.				.				NODE 16:				.				.				.			

	1	2	3	4	5	6	7	8	9	0			↑	↓	BS
													←	→	

• SRC IP ADDRESS

Enter the IP address for the GP at your station. To do this, separate the 32 bits of the IP address into four segments of eight bits each, delimit those segments with a dot, and then enter them as decimal numbers.

• DESTINATION IP ADDRESS

Enter the IP address of the other station (PLC).



When the GP unit's source IP Address is "0.0.0.0", the IP address designatd in the 2-Way Driver [SETUP ETHERNET INFORMATION] area becomes active.

◆ Ethernet Information Extended Settings

SETUP NETWORK EXT. INFORMATION										SET	CANCEL
SEND WAIT TIME		[0](ms)									
TIMEOUT		[0](x 2sec)									
IP ROUTER ADDRESS		[0].[0].[0].[0]									
SUBNET MASK		[0].[0].[0].[0]									
1	2	3	4	5	6	7	8	9	0		

- **SEND WAIT TIME**

Wait time can be added when a command is transmitted from the GP. Use the wait time if the traffic on the communications line is heavy. If no wait time is required, enter “0”.

- **TIMEOUT**

Enter the desired timeout value. If no response is received from the other station within the specified time, a timeout occurs. If “0” is specified, the default time is 15 seconds when it is TCP communication, and is 5 seconds when it is UDP communication.

- **IP ROUTER ADDRESS**

Enter the IP address of the router (only one). If no router is used, enter “0” in all fields.

- **SUBNET MASK**

Enter subnet masks. If no subnet mask is used, enter “0” in all fields.

■ Screen Editor Settings

Screen Editor settings are performed via the [GP Setup] -> [Communication Settings] feature. The setting items are described below.

The screenshot shows a dialog box titled "GP Settings - noname.tmp". It has three main tabs: "GP Settings", "I/O Settings", and "Mode Settings". Under "GP Settings", there are three sub-tabs: "Initial Screen Settings", "Extended Settings", and "Communication Settings". The "Communication Settings" sub-tab is selected. It contains the following fields and options:

- Source IP Address: 0. 0. 0. 0
- Source IP Port No.: 1024 (grayed out)
- Destination IP Address: 0. 0. 0. 0 (grayed out)
- Destination IP Port No.: 1024 (grayed out)
- Protocol Type: UDP, TCP
- Data Code: BINARY, ASCII

At the bottom right of the dialog is an "Advanced ..." button. At the very bottom are "OK", "Cancel", "Defaults", and "Help" buttons.

- **Source IP Address**

Enter the IP address for the GP at your station. To do this, separate the 32 bits of the IP address into four segments of eight bits each, delimit those segments with a dot, and then enter them as decimal numbers.

- **Source IP Port No. (Grayed out: disabled)**

- **Destination IP Address (Grayed out: disabled)**

- **Destination IP Port No. (Grayed out: disabled)**

(When using C-Package03 SP2 or later, "Destination Port No." will show "502")



Note: Protocol Type and Data Code settings cannot be performed.

◆ Advanced Communication Setup

The [Advanced Communication Setup] screen is as shown below.

Field Name	Value	Unit
Send Wait Time	0	msec
Time Out	1	x2 sec
IP Router Address	0. 0. 0. 0	
Subnet Mask	0. 0. 0. 0	
UDP Retry Count	2	

- **Send Wait Time (0 to 255)**

Wait time can be added when a command is transmitted from the GP. Use the wait time if the traffic on the communications line is heavy. If no wait time is required, enter “0”.

- **Time Out (0 to 65535)**

Enter the desired timeout value. If no response is received from the other station within the specified time, a timeout occurs. If “0” is specified, the default time is 15 seconds.

- **IP Router Address**

Enter the IP address of the router (only one). If no router is used, enter “0” in all fields.

- **Subnet Mask**

Enter subnet masks. If no subnet mask is used, enter “0” in all fields.

◆ Mode Network Information Settings

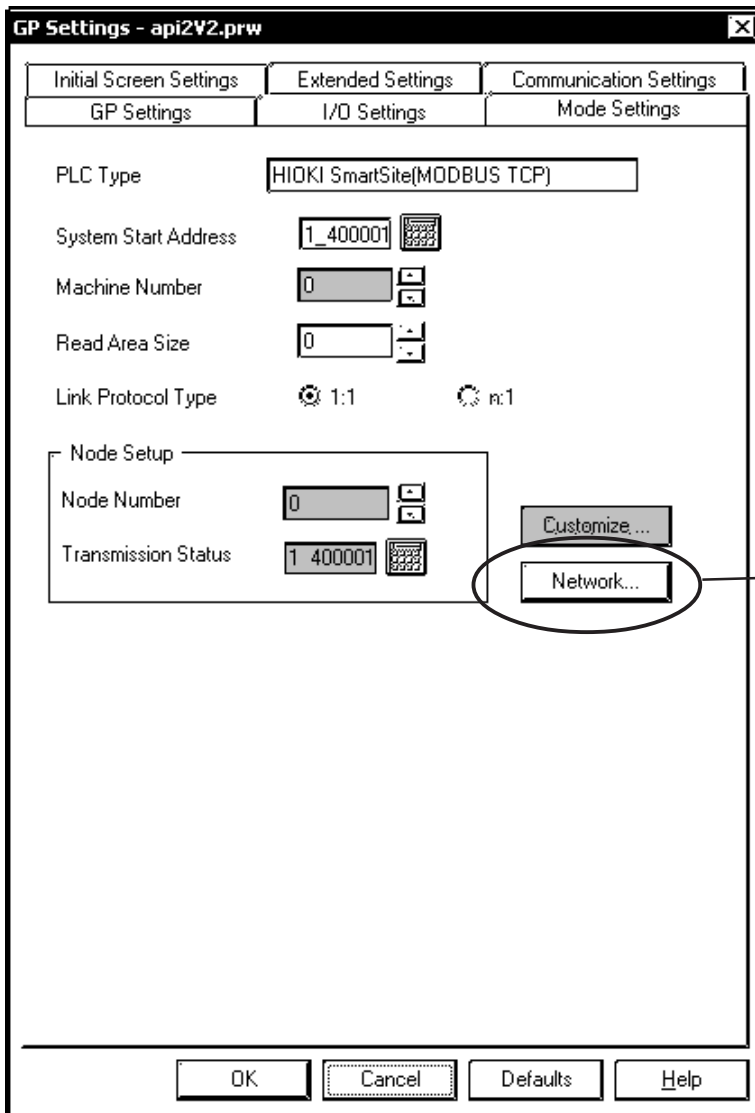

Sets the destination node controller's IP address

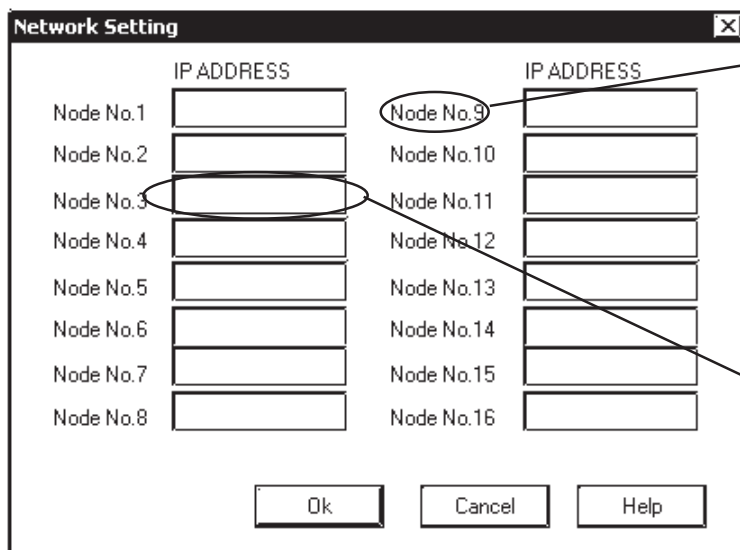

Node numbers are designated when setting a tag's addresses. Access is then performed for the controller designated by this IP address. This number has no connection to the Modbus Slave Address number.

Enter the controller IP addresses here. (Each byte can be from 0 to 255.) Default is empty.

4

Error Codes**■ PLC SPECIFIC ERROR CODES**

PLC error codes are displayed in the left lower corner of the GP screen in the format shown below. ** indicates PLC specific error codes.

Host Communication Error (02:)**

PLC Error Code

Error Code	Type	Description
01	Function Code Error	Designated function code does not exist.
02	Address Error	Designated function code designates an unusable address.
03	Value Error	Designated address value does not exist.
04	Other Errors	Module does not exist. Communication error.

A

Hioki E.E. Corporation

A.1

Maximum Number of Consecutive Device Addresses

The following lists the maximum number of consecutive addresses that can be read by each PLC. Refer to these tables to utilize *Block Transfer*.



Note: When the device is setup using the methods below, the Data Communication Speed declines by the number of times the device is read.

- When consecutive addresses exceed the maximum data number range
- When an address is designated for *division*
- When device types are different

To speed up data communication, plan the tag layout in screen units, as consecutive devices. (Includes the Alarm and Trend screens.)

■ PLCs

<Hioki Smart Site Series>

Device	Maximum Number of Consecutive Addresses
Coils	80 Words
Discrete Input	
Input Register	
Holding Register	

A.2

Device Codes and Address Codes

Device codes and address codes are used to specify indirect addresses for the E-tags or K-tags.

The word addresses of data to be displayed are coded and stored in the word address specified by the E-tags and K-tags. (Code storage is done either by the PLC, or with T-tag and K-tags)

■ Hioki E.E. Corporation Controllers

<Smart Site Series>



Note:

With this protocol, indirect address designations can not be used with E-tags and K-tags.

A.3

Address Conversion Table

		After Conversion				
		0	1	4	3	LS
Before Conversion	Coils 0	○	○	○	○	○
	Discrete Input 1	○	○	○	○	○
	Holding Register 4	○	○	○	○	○
	Input Register 3	○	○	○	○	○
	System Area (LS)	○	○	○	○	○

○ : If Conversion Mode is "Word", both word and bit devices will be converted.
 If Conversion Mode is "Bit", only bit devices will be converted.

Protocol Stack Error Codes

Protocol Stack Error Codes are displayed on the GP as follows.

Host communication error (02:FE:**)

** represents one of the following error codes, from 00 to F0.

Error Code	Description	Notes
00	There is a setup error related to the IP address of your station at initialization.	
05	Initialization has failed.	
06	Cancelling of communications has failed.	
07	An attempt was made to establish a connection before initialization was successfully completed.	
08	Your station's port number is incorrect	
09	The destination station's port number is incorrect.	
0A	The IP address of the other station is incorrect.	
0B	The same port number is already being used by UDP for establishing the connection.	
0C	The same port number is already being used by TCP for establishing the connection.	
0D	Protocol stack has refused connection establishment.	
0E	Protocol stack has returned the unsuccessful establishment of a connection.	
0F	The connection has been shut down.	
10	All connections are busy. No connection is available.	
13	Your station was aborted by a different station.	
30	There was no reply from the protocol stack.	
32	There was no reply from the other station.	*1*2
40	No network information exists for the designated node.	*1
41	I/O memory type of the random read-out response data is incorrect.	*1
42	Network information does not exist.	
F0	Undefined error.	

*1 When using an OMRON Corporation CS1/CJ/CJ1M Series unit, the error code will appear on the GP screen as shown below. Also, behind the Ethernet error code will appear the designated Network and Node addresses.

Host Communication Error (02:FE:**:###:###)

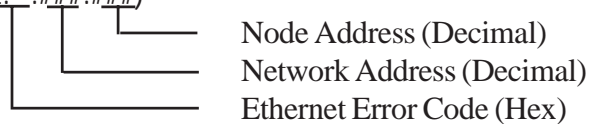

*2 When using a Hitachi Industrial Equipment Corporation's HIDIC H Series or a Schneider Corporation MODBUS TCP unit, the error code will appear on the GP screen as shown below. Also, behind the Ethernet error code will appear the designated Node address.

Host Communication Error (02:FE:**:###:###)

