

Device/PLC Connection Manuals



About the Device/PLC Connection Manuals

Prior to reading these manuals and setting up your device, be sure to read the "Important: Prior to reading the Device/PLC Connection manual" information. Also, be sure to download the "Preface for Trademark Rights, List of Units Supported, How to Read Manuals and Documentation Conventions" PDF file. Furthermore, be sure to keep all manual-related data in a safe, easy-to-find location.

12.4 RKC INSTRUMENT INC. Controllers

12.4.1 System Structure

The following describes the system configuration used when connecting the GP/GLC/LT to an RKC Controller.





important



GP/GLC/LT's System Area (LS0 to LS19) Settings

The GP/GLC/LT's system area (20 words) cannot be allocated to the Controller's own data area. When you are entering the system area settings via the screen editor software or via the GP/GLC/LT's OFFLINE screen, be careful that you do not use the Controller's own data area.

■ CB Series (Modbus protocol)

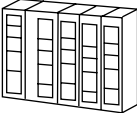

Controller	Cable Diagram	GP/GLC/LT
		
CB100 Z-1021 CB400 Z-1021 CB500 Z-1021 CB700 Z-1021 CB900 Z-1021 (Applicable for Modbus Protocol)	RS-422(2-wire) (Cable Diagram 3)	GP / GLC Series LT Type C
	RS-422(2-wire) 1:n connection (Cable Diagram 5)	

■ SR-Mini Series (Modbus protocol)

Controller	Cable Diagram	Cables	GP/GLC/LT
			
H-PCP-AZ-1021	RS-232C (Cable Diagram 1)	RKC's W-BF-01-□□□□ *1	GP / GLC Series LT Type C
	RS-422(4-wire) (Cable Diagram 2)		
	RS-422(4-wire) 1:n Connection (Cable Diagram 4)	RKC's W-BF-01-□□□□ *1 W-BF-02-□□□□	

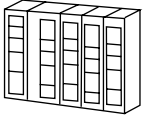

*1 □□□□ indicates cable length (in mm).

■ SR Mini HG Series (Modbus protocol)

Controller *1	Cable Diagram	GP/GLC/LT
		
H-PCP-J-□4□-D*□□	RS-422(4-wire) (Cable Diagram 11)	GP/GLC Series LT Type C
	RS-422(4-wire) 1:n connection (Cable Diagram 12)	
H-PCP-J-□5□-D*□□	RS-422(2-wire) (Cable Diagram 13)	
	RS-422(2-wire) 1:n connection (Cable Diagram 14)	
H-PCP-J-□□1-D*□□	RS-232C (Cable Diagram 15)	
H-PCP-J-□□4-D*□□	RS-422(4-wire) (Cable Diagram 11)	
	RS-422(4-wire) 1:n connection (Cable Diagram 12)	
H-PCP-J-□□5-D*□□	RS-422(2-wire) (Cable Diagram 13)	
	RS-422(2-wire) 1:n connection (Cable Diagram 14)	

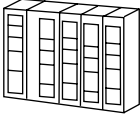

*1 The model data, indicated by "□", will vary depending on the type of option.

■ MA900 Series (Modbus protocol)

Controller *1	Cable Diagram	GP/GLC/LT
		
MA900-4□□□□□□□*□□□□6/□	RS-422(2-wire) (Cable Diagram 18) RS-422(2-wire) 1:n connection (Cable Diagram 19)	GP/GLC Series LT Type C
MA900-4□□□□□□□*□□□□7/□	RS-422(4-wire) (Cable Diagram 16) RS-422(4-wire) 1:n connection (Cable Diagram 17)	
MA900-4□□□□□□□*□□□□8/□	RS-232C (Cable Diagram 20)	
MA901-8□□□□□□□*□□□□6/□	RS-422(2-wire) (Cable Diagram 18) RS-422(2-wire) 1:n connection (Cable Diagram 19)	
MA901-8□□□□□□□*□□□□7/□	RS-422(4-wire) (Cable Diagram 16) RS-422(4-wire) 1:n connection (Cable Diagram 17)	
MA900-8□□□□□□□*□□□□8/□	RS-232C (Cable Diagram 20)	

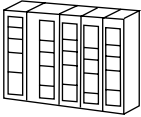

*1 The model data, indicated by "□", will vary depending on the type of option.

■ HA900 Series (Modbus protocol)

Controller *1	Cable Diagram	GLC/GP/LT
		
HA900-□□□□□*□□□□□8□□□□	RS-232C (Cable Diagram 20)	GP/GLC Series LT Type C
HA900-□□□□□*□□□□□6□□□□	RS-422(2-wire) (Cable Diagram 18)	
	RS-422(2-wire) 1:n connection (Cable Diagram 19)	
HA900-□□□□□*□□□□□7□□□□	RS-422(4-wire) (Cable Diagram 16)	
	RS-422(4-wire) 1:n connection (Cable Diagram 17)	
HA900-□□□□□*□□□□□8□□□□	RS-232C (Cable Diagram 20)	
HA901-□□□□□*□□□□□6□□□□	RS-422(2-wire) (Cable Diagram 18)	
	RS-422(2-wire) 1:n connection (Cable Diagram 19)	
HA901-□□□□□*□□□□□8□□□□	RS-232C (Cable Diagram 20)	
HA901-□□□□□*□□□□□6□□□□	RS-422(2-wire) (Cable Diagram 18)	
	RS-422(2-wire) 1:n connection (Cable Diagram 19)	
HA901-□□□□□*□□□□□7□□□□	RS-422(4-wire) (Cable Diagram 16)	
	RS-422(4-wire) 1:n connection (Cable Diagram 17)	
HA901-□□□□□*□□□□□8□□□□	RS-232C (Cable Diagram 20)	

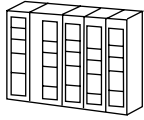

*1 The model data, indicated by "□", will vary depending on the type of option.

■ HA400 Series (Modbus protocol)

Controller *1	Cable Diagram	GP/GLC/LT
		
HA400-□□-□□-□*□□-□□□□6□-□/□/□	RS-422(2-wire) (Cable Diagram 18) RS-422(2-wire) 1:n connection (Cable Diagram 19)	GP/GLC Series LT Type C
HA400-□□-□□-□*□□-□□□□8□-□/□/□	RS-232C (Cable Diagram 20)	
HA400-□□-□□-□*□□-□□□□6□-□/□/□	RS-422(2-wire) (Cable Diagram 18) RS-422(2-wire) 1:n connection (Cable Diagram 19)	
HA400-□□-□□-□*□□-□□□□7□-□/□/□	RS-422(4-wire) (Cable Diagram 16) RS-422(4-wire) 1:n connection (Cable Diagram 17)	
HA400-□□-□□-□*□□-□□□□8□-□/□/□	RS-232C (Cable Diagram 20)	
HA401-□□-□□-□*□□-□□□□6□-□/□/□	RS-422(2-wire) (Cable Diagram 18) RS-422(2-wire) 1:n connection (Cable Diagram 19)	
HA401-□□-□□-□*□□-□□□□8□-□/□/□	RS-232C (Cable Diagram 20)	
HA401-□□-□□-□*□□-□□□□6□-□/□/□	RS-422(2-wire) (Cable Diagram 18) RS-422(2-wire) 1:n connection (Cable Diagram 19)	
HA401-□□-□□-□*□□-□□□□7□-□/□/□	RS-422(4-wire) (Cable Diagram 16) RS-422(4-wire) 1:n connection (Cable Diagram 17)	
HA401-□□-□□-□*□□-□□□□8□-□/□/□	RS-232C (Cable Diagram 20)	

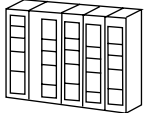

*1 The model data, indicated by "□", will vary depending on the type of option.

■ SA200 Series (Modbus protocol)

Controller *1	Cable Diagram	GP/GLC/LT
		
SA200□□□□□□*□□6□/□/□□	RS-422(2-wire) (Cable Diagram 18) RS-422(2-wire) 1:n connection (Cable Diagram 19)	GP/GLC Series LT Type C

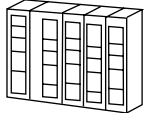

*1 The model data, indicated by "□", will vary depending on the type of option.

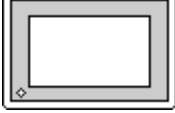
■ SRX Series (Modbus protocol)

Controller *1	Cable Diagram	GP/GLC/LT
		
X-TIO-A-□□□□*□□	RS-422(2-wire) (Cable Diagram 21) RS-422(2-wire) 1:n connection (Cable Diagram 22)	GP/GLC Series LT Type C

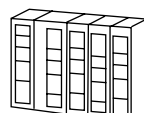

*1 The model data, indicated by "□", will vary depending on the type of option.

■ SRV Series (Modbus protocol)

Controller *1	Cable Diagram	GP/GLC/LT
		
V-TIO-A-□□□□*□□	RS-422(2-wire) (Cable Diagram 21) RS-422(2-wire) 1:n connection (Cable Diagram 22)	GP/GLC Series LT Type C

*1 The model data, indicated by "□", will vary depending on the type of option.

■ CB Series (RKC protocol)



Controller *1	Cable Diagram	GP/GLC/LT
		
CB100□□□□-□□*□□-5□/□ CB400□□□□-□□*□□-5□/□ CB500□□□□-□□*□□-5□/□ CB700□□□□-□□*□□-5□/□ CB900□□□□-□□*□□-5□/□	RS-422(2-wire) (Cable Diagram 6) RS-422(2-wire) 1:n Connection (Cable Diagram 7)	GP/GLC Series *2 LT Type C

*1 The model data "□" will vary depending on the type of option.

For detailed temperature Controller information, refer to that unit's catalog. Units that have an option of serial data transfer will have a "5" in their model code.

*2 This unit can be used with GP-377 Series, GP77R Series, GP2000 Series, and GLC2000 Series Units.

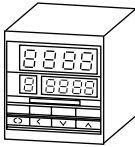
■ REX-F Series (RKC protocol)



Controller *1	Cable Diagram	GP/GLC/LT
		
F400□□□□-□□*□□-□□□-1□ F700□□□□-□□*□□-□□□-1□ F900□□□□-□□*□□-□□□-1□	RS-232C (Cable Diagram 8)	GP/GLC Series *2 LT Type C
F400□□□□-□□*□□-□□□-4□ F700□□□□-□□*□□-□□□-4□ F900□□□□-□□*□□-□□□-4□	RS-422(4-wire) (Cable Diagram 9) RS-422(4-wire) 1:n Connection (Cable Diagram 10)	GP/GLC Series *2 LT Type C
F400□□□□-□□*□□-□□□-4□ F700□□□□-□□*□□-□□□-4□ F900□□□□-□□*□□-□□□-4□	RS-422(2-wire) (Cable Diagram 6) RS-422(2-wire) 1:n Connection (Cable Diagram 7)	GP/GLC Series *2 LT Type C

*1 The model data "□" will vary depending on the type of option.

For detailed temperature Controller information, refer to that unit's catalog. Serial data transfer option types use a "1" for RS-232C, "4" for RS-422 - 4 wire, and "5" for RS-422 - 2 wire.

*2 This unit can be used with GP-377 Series, GP77R Series, GP2000 Series, and GLC2000 Series Units.

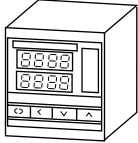
■ LE-100 Series (RKC protocol)

Controller ^{*1}	Cable Diagram	GP/GLC/LT ^{*2}
		
LE100-□□*□5□□-□□	RS-422(2-wire) (Cable Diagram 6)	GP/GLC Series LT Type C
	RS-422(2-wire) 1:n Connection (Cable Diagram 7)	

*1 The model data "□" will vary depending on the type of option.

For detailed temperature Controller information, refer to that unit's catalog.
Units that have an option of serial data transfer will have a "5" in their model code.

*2 This unit can be used with GP-377 Series, GP77R Series, GP2000 Series, and GLC2000 Series Units.

◆ Connections

•1:1 connection

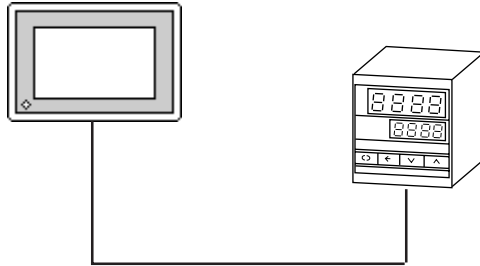

•1:n connection

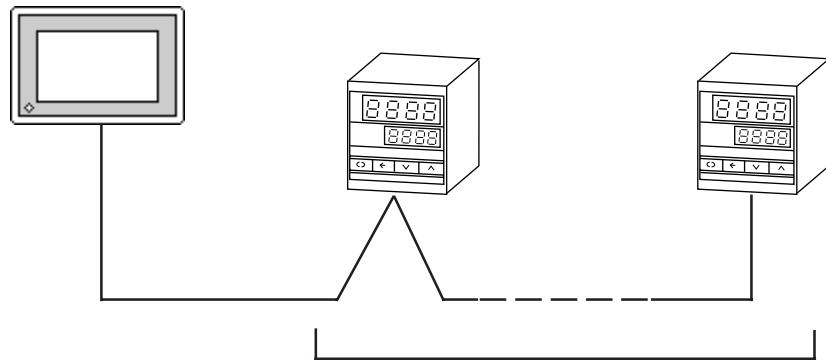

31 units max.

(Max. with SR-Mini Series and SR Mini HG Series units is 16 units)

12.4.2 Cable Diagrams

The cable diagrams shown below and the cable diagrams recommended by RKC INSTRUMENT INC. may differ, however, using these cables for your Controller’s operations will not cause any problems.



- **When connecting the FG terminal to the connector cover, be sure that the connector cover conducts current.**
- **Ground your Controller's FG terminal according to your country's applicable standard. For details, refer to your Controller’s manual.**
- **When connecting a cable’s Shield line to an FG terminal, consider the needs of your system when deciding which side of the cable (GP/GLC or Controller) to connect. (The example below connects to the Controller’s FG terminal.)**

■ **CB Series**



- **Up to 31 CB Series units can be connected to a single GP/GLC/LT.**
- **If a communications cable is used, be sure to connect its SG (signal ground) terminal.**
- **The following RS-422 cable is recommended.**

Company	Item No.	Type
Hirakawa Densen	2207-510-008	CO-HC-ESV-3P X 7/0.2

- **The Controller terminal number will differ depending on the type of CPU used. The following examples reflect all the CB Series units supported by the Digital Electronics Corporation.**

Signal Name	Terminal No.	
	CB100, CB400, CB500, CB900	CB700
SG	13	7
T/R(A)	14	8
T/R(B)	15	9

■ **SR-Mini Series / SR Mini HG Series**



- **Up to 16 SR-Mini Series/SR Mini HG Series modules can be connected to a single GP/GLC/LT.**
- **If a communications cable is used, be sure to connect its SG (signal ground) terminal.**
- **RS-232C cables should be 15 meters or less.**
- **RS-422 (2-wire) cables should be 500 meters or less.**
- **The following RS-422 cables are recommended for SR-Mini Series units.**

Company	Type	Comments
RKC INSTRUMENT INC.	W-BF-01- XXXX *1	Used when connecting an SR-Mini to a GP/GLC/LT
RKC INSTRUMENT INC.	W-BF-02- XXXX *1	Used when connecting an SR-Mini to an SR-Mini

*1 XXXX indicates the cable length (mm).

■ **REX-F Series**



- **Up to 31 REX-F Series units can be connected to a single GP/GLC/LT.**
- **Connect the shield to the GP/GLC/LT's FG terminal.**
- **If a communications cable is used, be sure to connect its SG (signal ground) terminal.**
- **RS-232C cables must be 15 meters or less.**
- **RS-422 cables must be 600 meters or less.**
- **With REX-F Series units, the terminal numbers and signal names will vary, depending on the unit's model type and data transfer method used. The following tables show the possible model type and signal name combinations.**

◆ RS-232C Connections

Terminal No.			Signal Name
F400	F700	F900	
12	16	26	SG
13	17	27	SD
14	18	28	RD

◆ RS-422 (2-wire) Connections

Terminal No.			Signal Name
F400	F700	F900	
12	16	26	SG
13	17	27	T/R(A)
14	18	28	T/R(B)

◆ RS-422 (4-wire) Connections

Terminal No.			Signal Name
F400	F700	F900	
12	16	26	SG
13	17	27	T(A)
14	18	28	T(B)
15	19	29	R(A)
16	20	30	R(B)

■ LE100 Series



- Up to 31 LE100 Series units can be connected to a single GP/GLC/LT.
- Connect the shield to the GP/GLC/LT's FG terminal.
- If a communications cable is used, be sure to connect its SG (signal ground) terminal.
- RS-422 cables must be 600 meters or less.
- LE100 Series data transfer signal names are as follows:

Terminal No.	Signal Name
1	T/R(A)
2	T/R(B)
3	SG

Cable Diagram 1 (1:1) RS-232C

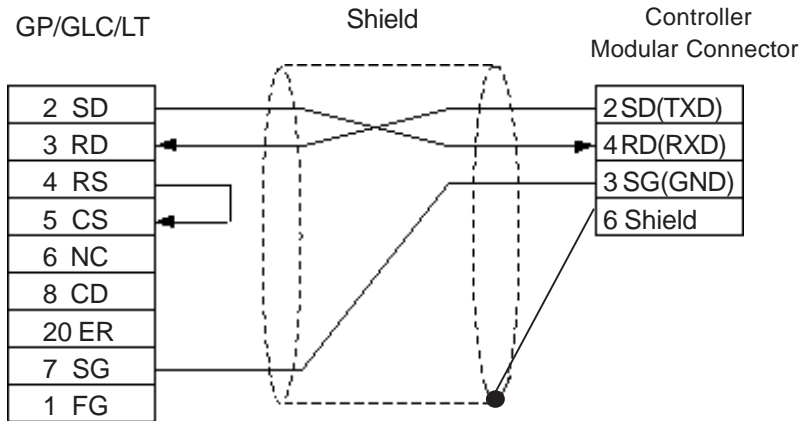

Cable Diagram 2 (1:1) RS-422 4-Wire

<When using Digital's RS-422 connector terminal adapter GP070-CN10-O>

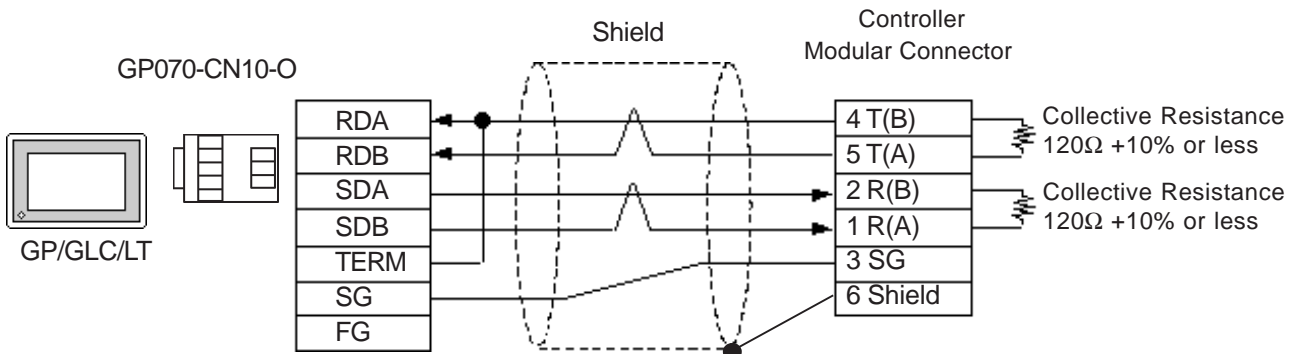

<When making your own cable>

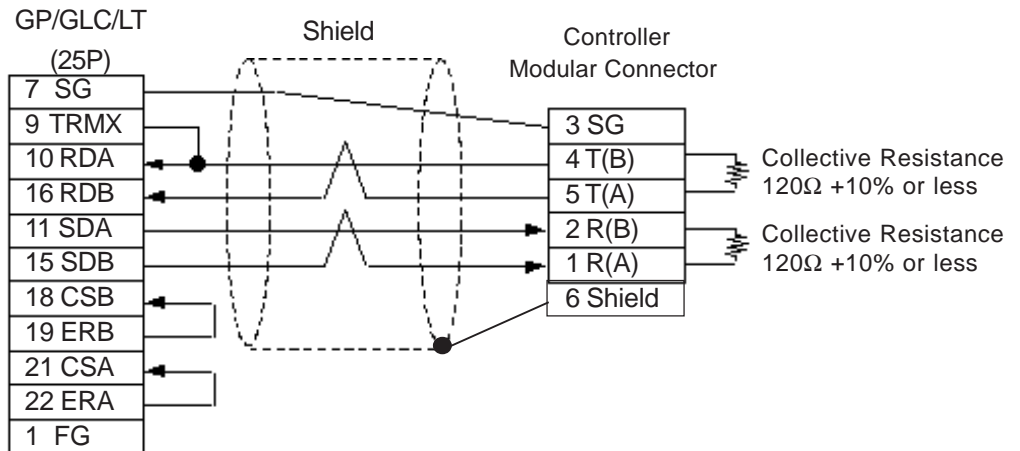

Cable Diagram 3 (1:1) RS-422 2-Wire

<When using Digital's RS-422 connector terminal adapter GP070-CN10-O>

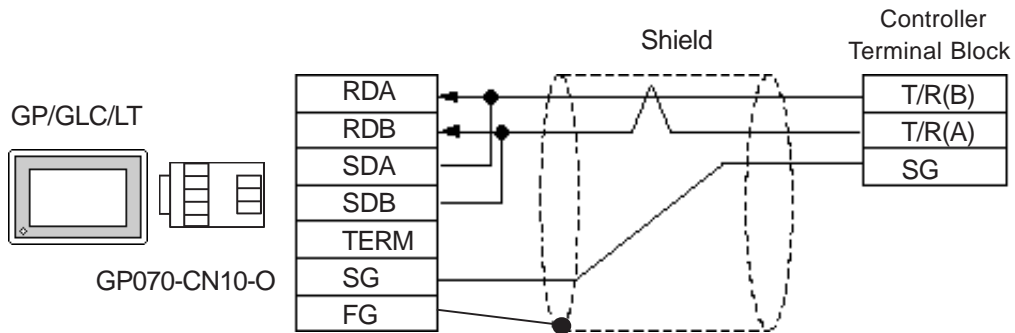

<When making your own cable>

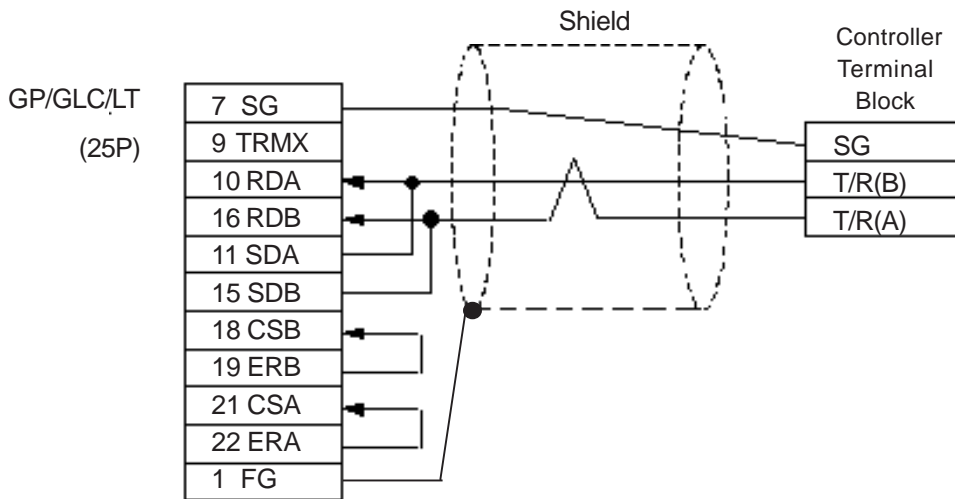

Cable Diagram 4 (1:n) RS-422 4-Wire

<When using Digital's RS-422 connector terminal adapter GP070-CN10-O>

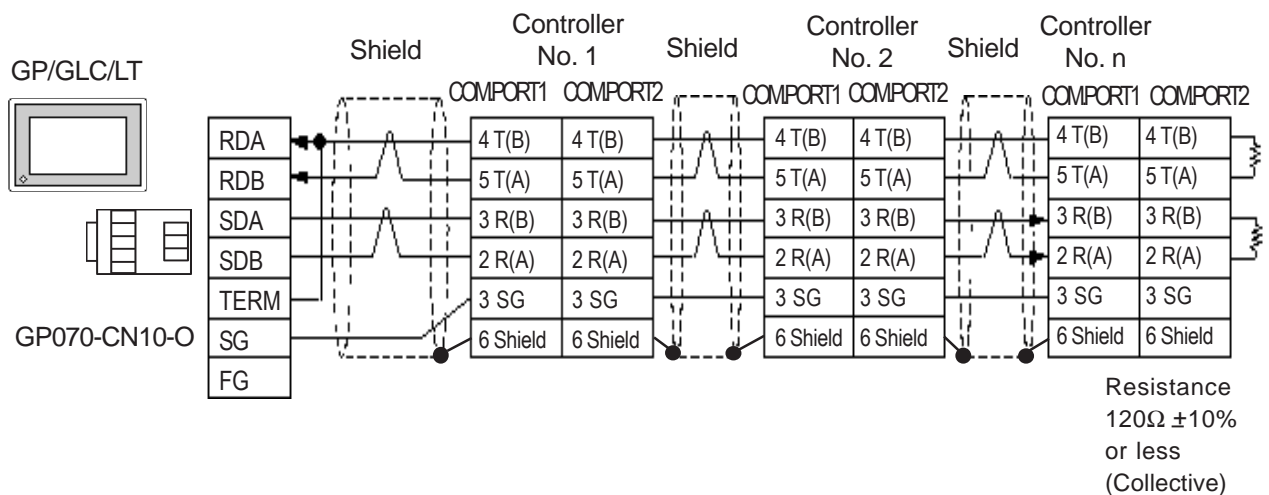

<When making your own cable>

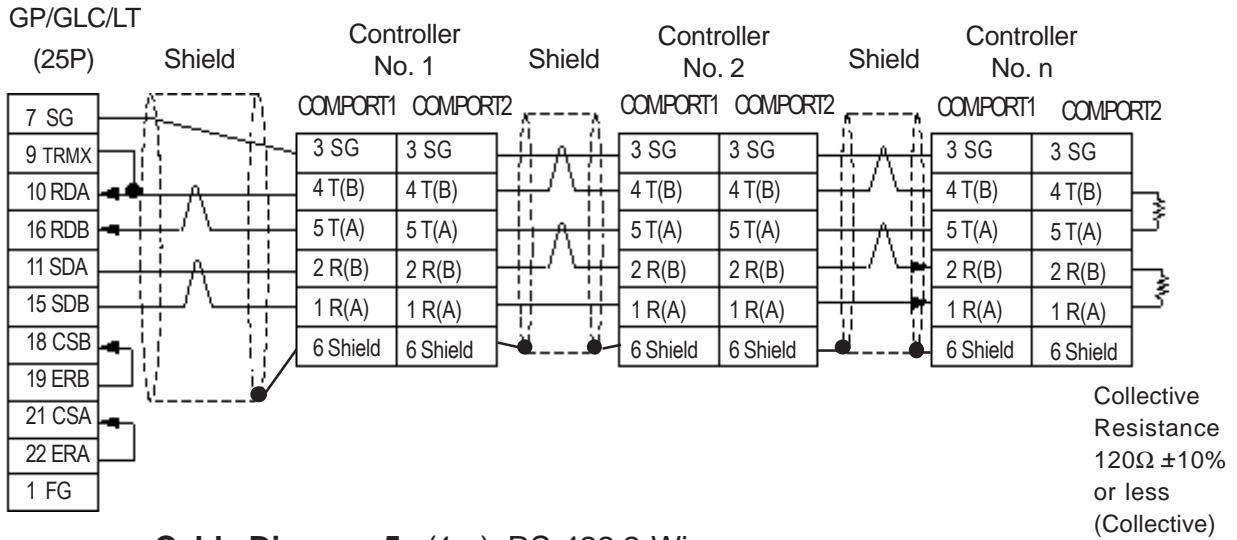

Cable Diagram 5 (1:n) RS-422 2-Wire

<When using Digital's RS-422 connector terminal adapter GP070-CN10-O>

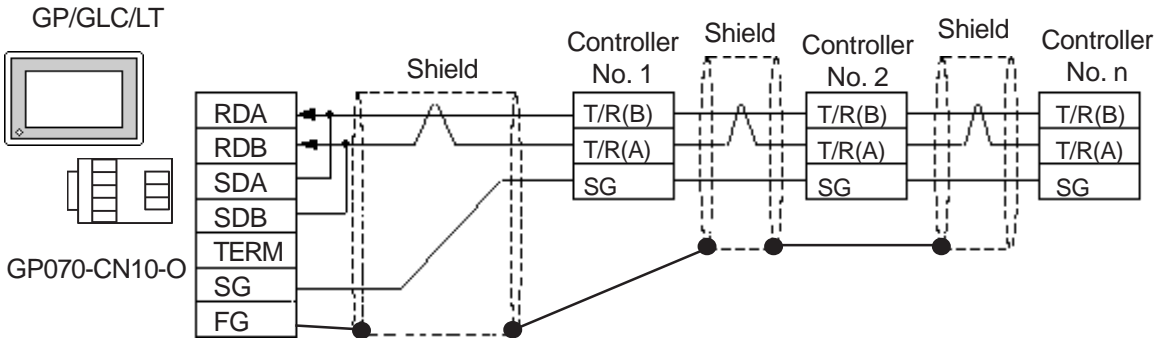

<When making your own cable>

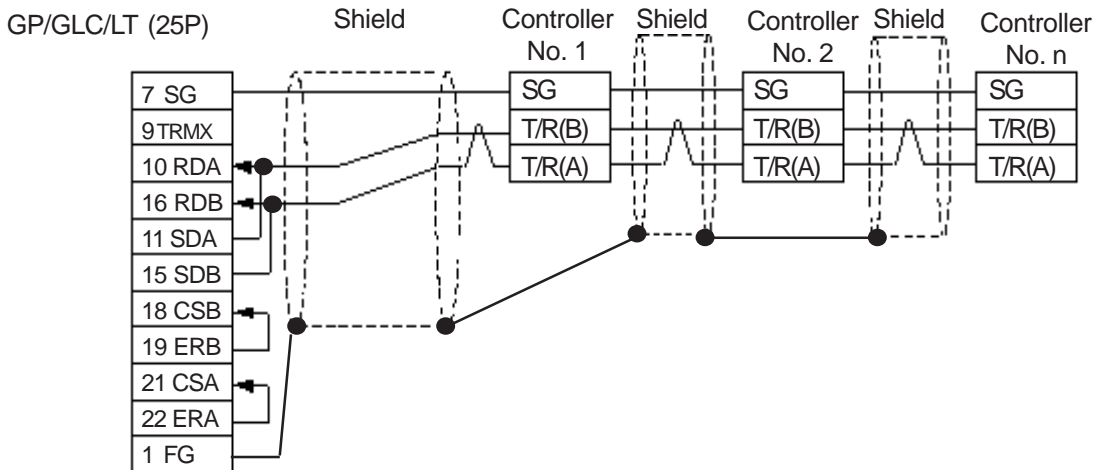

Cable Diagram 6 (1:1) RS-422 2-Wire

<When using Digital's RS-422 connector terminal adapter GP070-CN10-O>

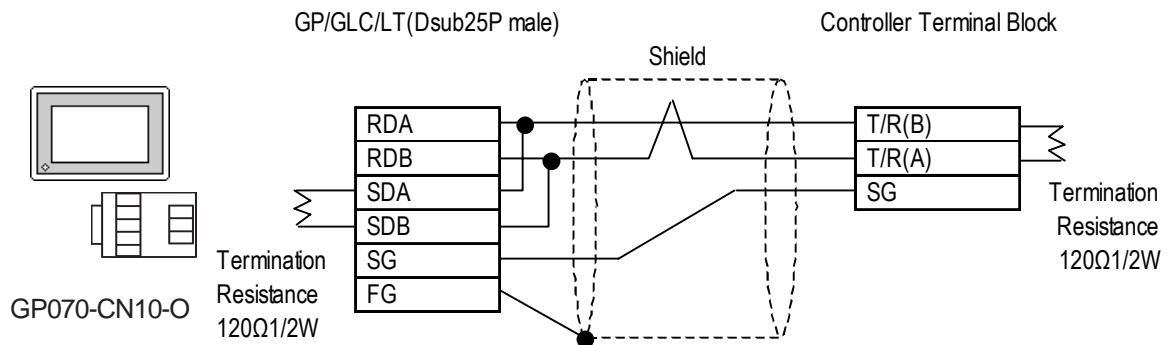

<When making your own cable>

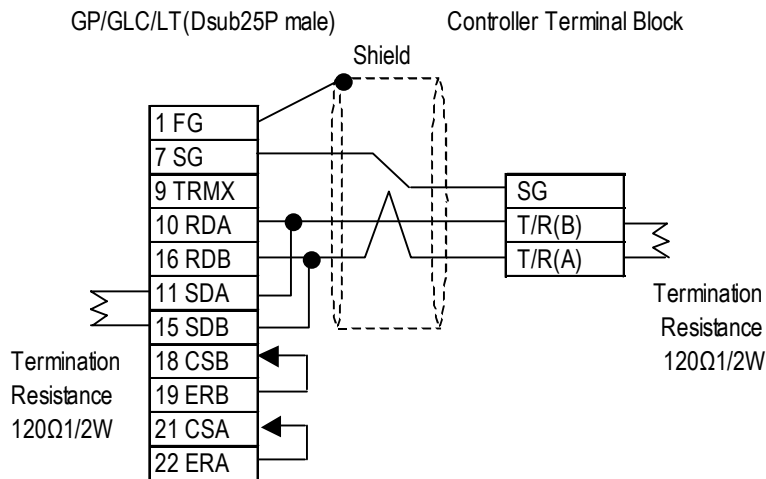

Cable Diagram 7 (1:n) RS-422 2-Wire

<When using Digital's RS-422 connector terminal adapter GP070-CN10-O>

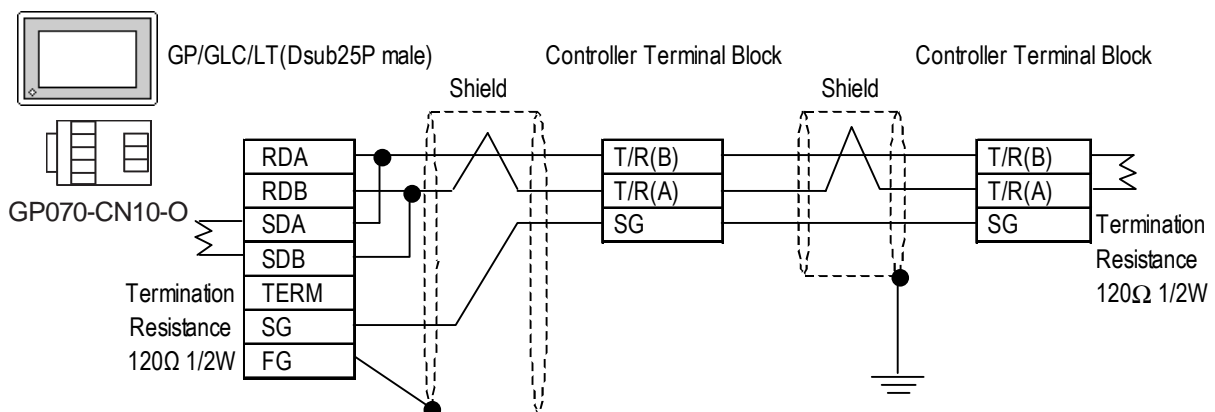

<When making your own cable>

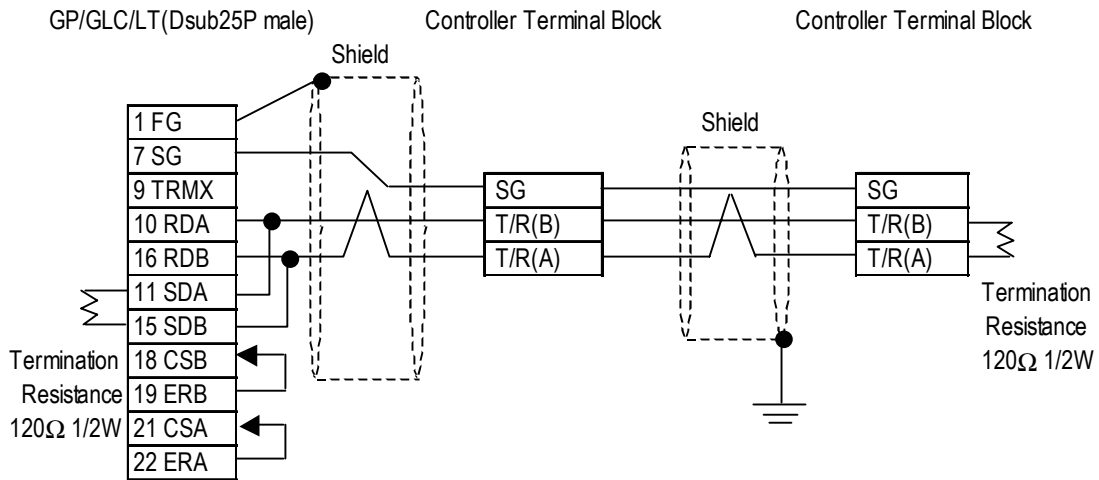

Cable Diagram 8 (1:1) RS-232C

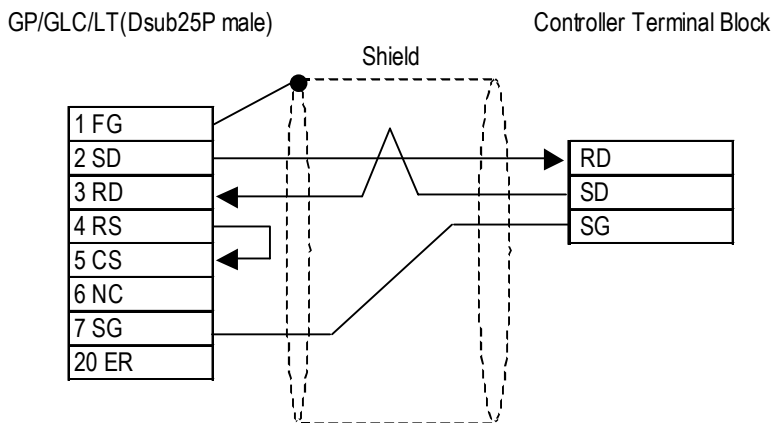

Cable Diagram 9 (1:1) RS-422 4-Wire

<When using Digital's RS-422 connector terminal adapter GP070-CN10-0>

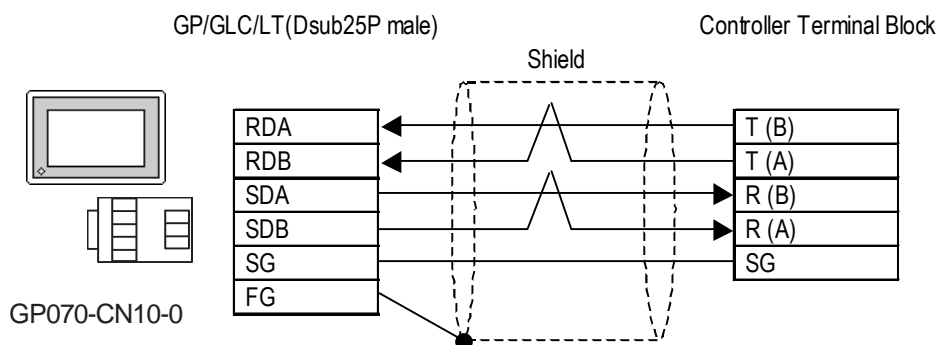

<When making your own cable>

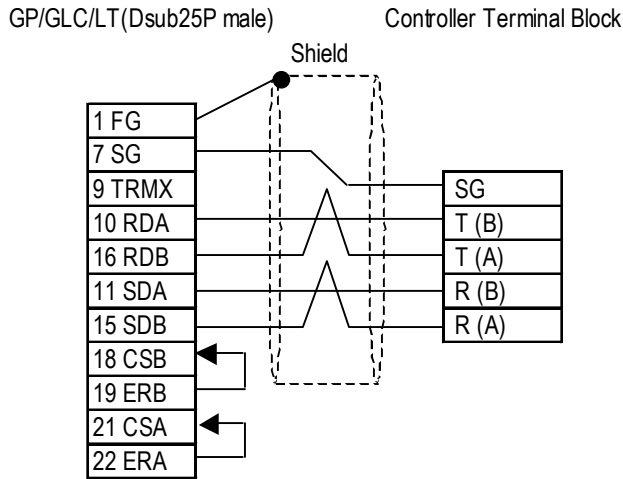

Cable Diagram 10 (1:n) RS-422 4-Wire

<When using Digital's RS-422 connector terminal adapter GP070-CN10-O>

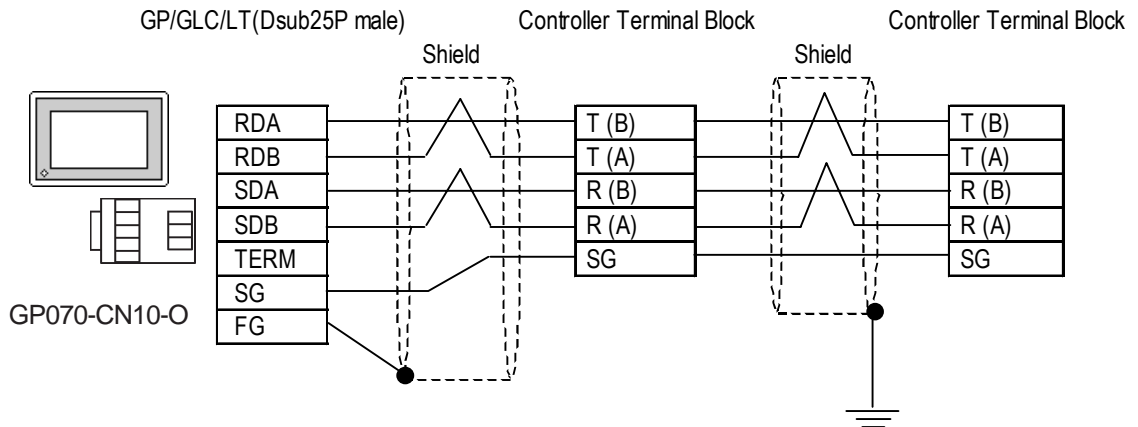

<When making your own cable>

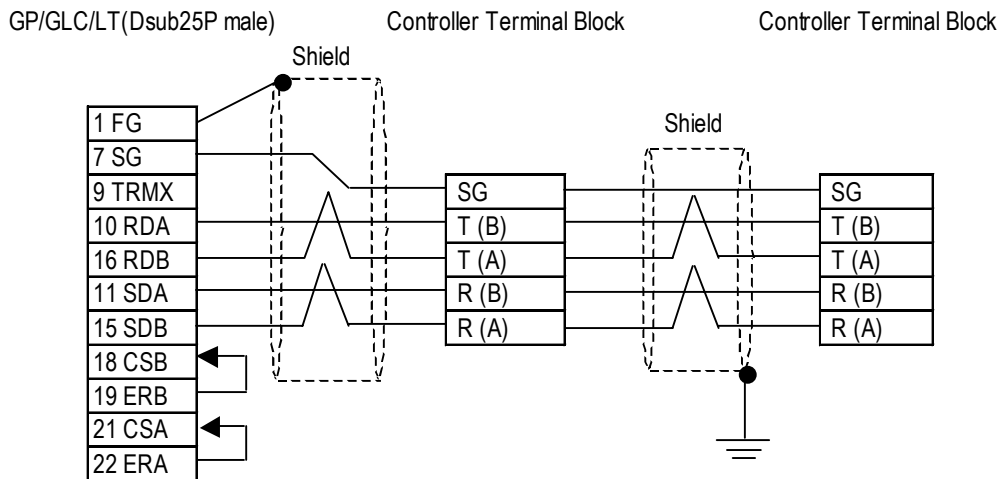

Cable Diagram 11 (1:1) RS-422 4-Wire

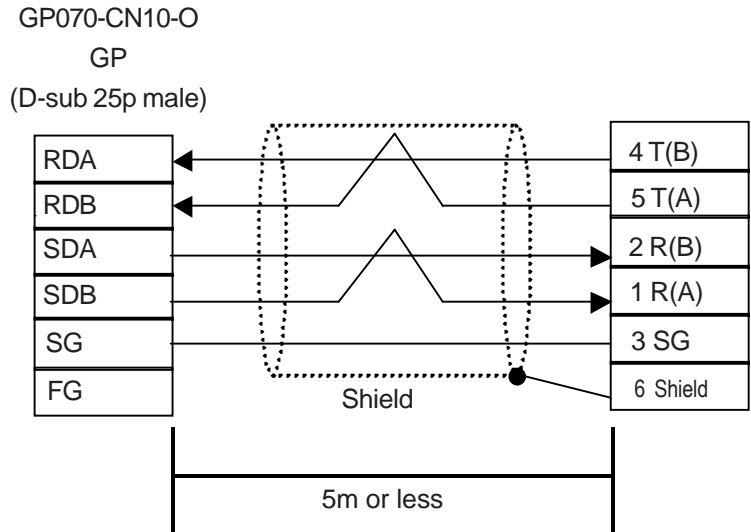

Termination resistance is not required.

<When making your own cable>

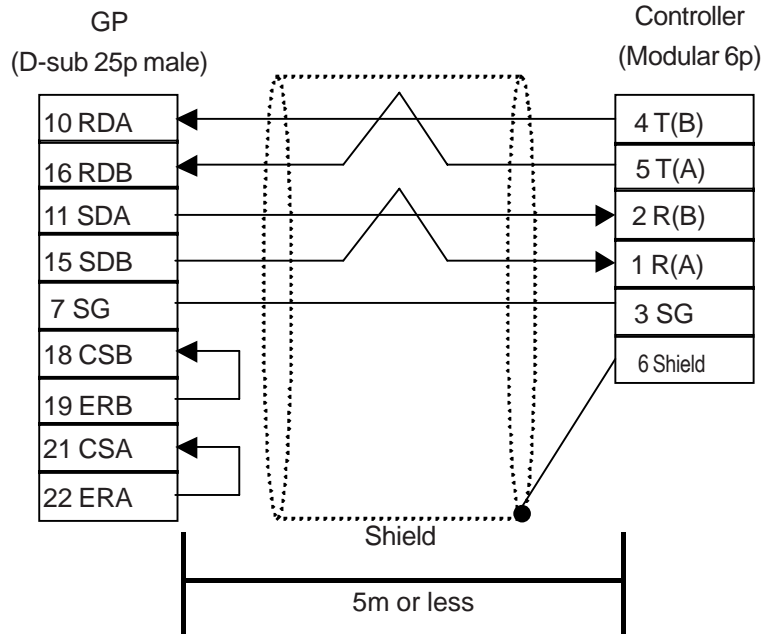

Termination resistance is not required.

Cable Diagram 12 (1:n) RS-422 4-Wire

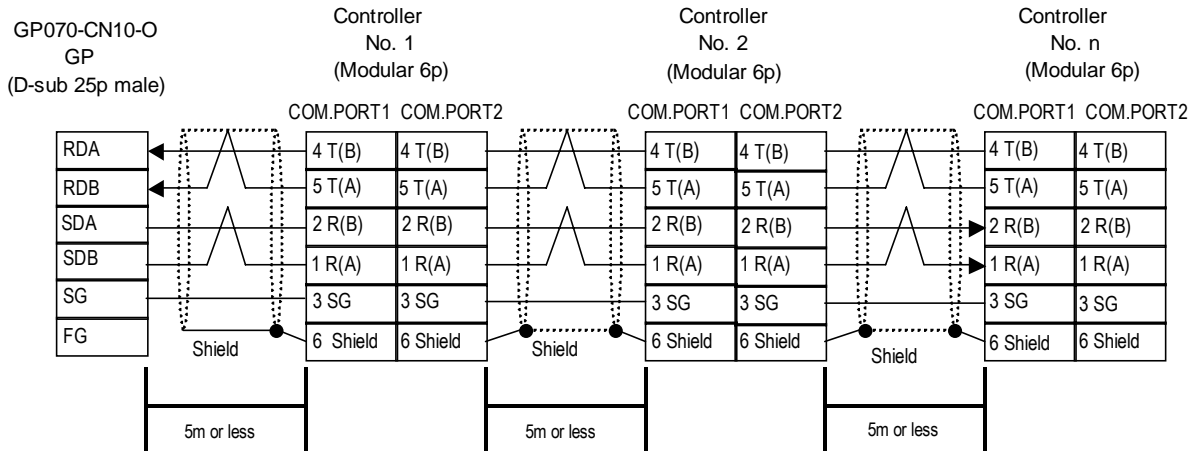

- **Termination resistance is not required.**
- **A maximum of 16 controllers can be connected to the GP unit.**

<When making your own cable>

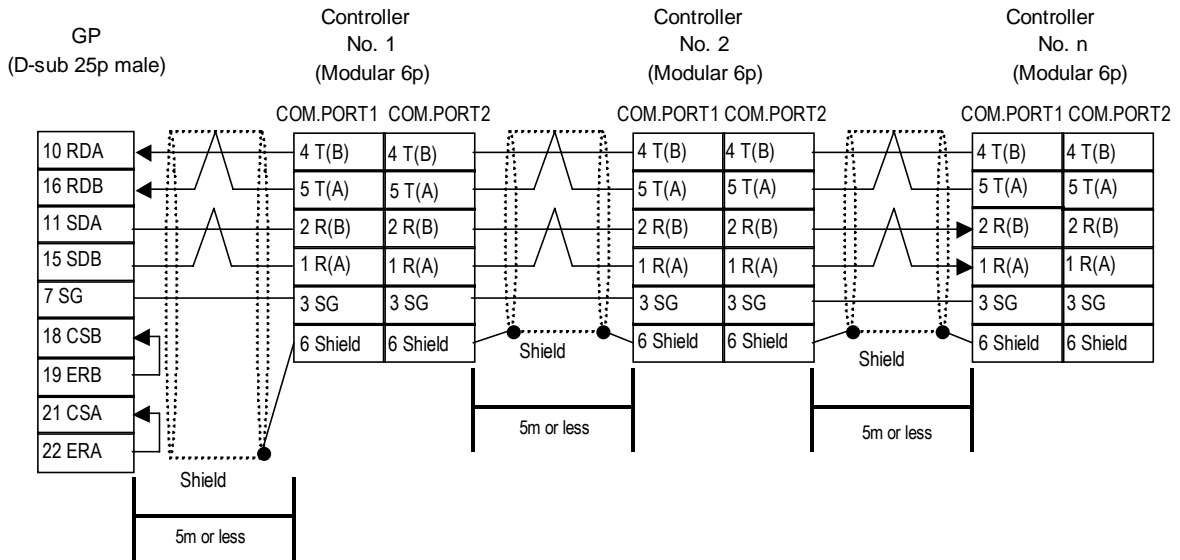

- **Termination resistance is not required.**
- **A maximum of 16 controllers can be connected to the GP unit.**

Cable Diagram 13 (1:1) RS-422 2-Wire

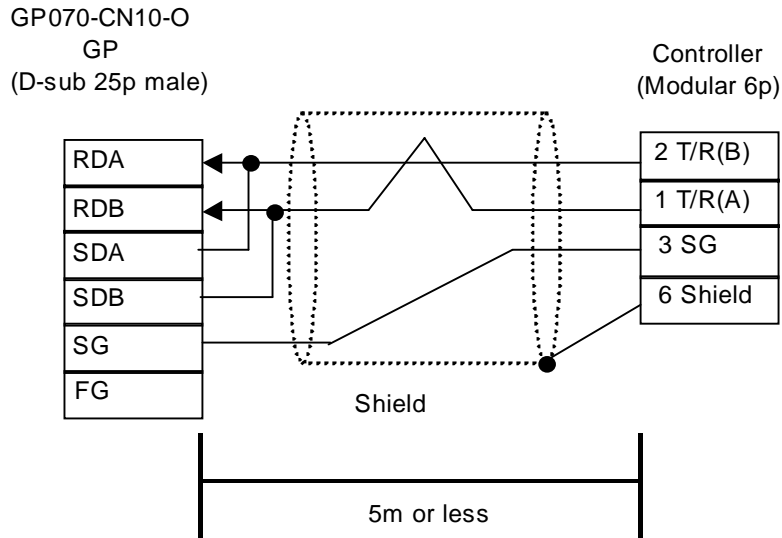

Termination resistance is not required.

<When making your own cable>

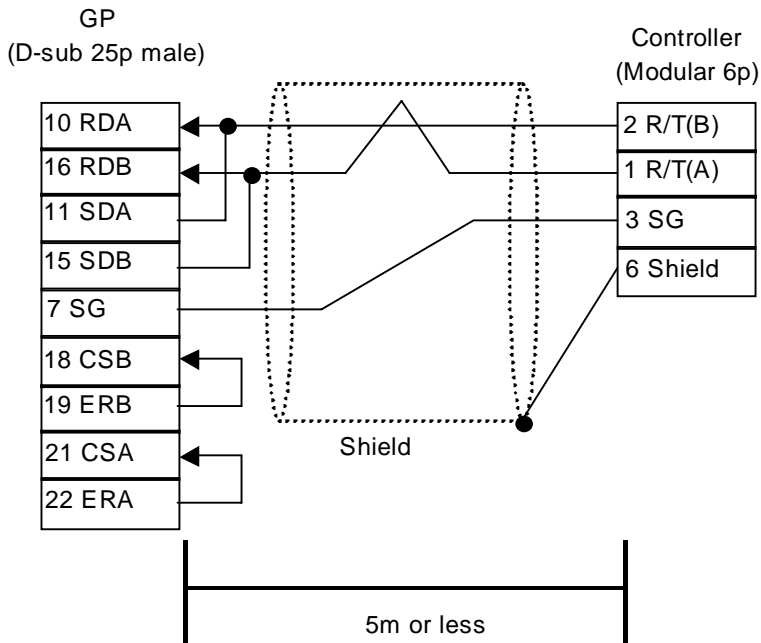

Termination resistance is not required.

Cable Diagram 14 (1:n) RS-422 2-Wire

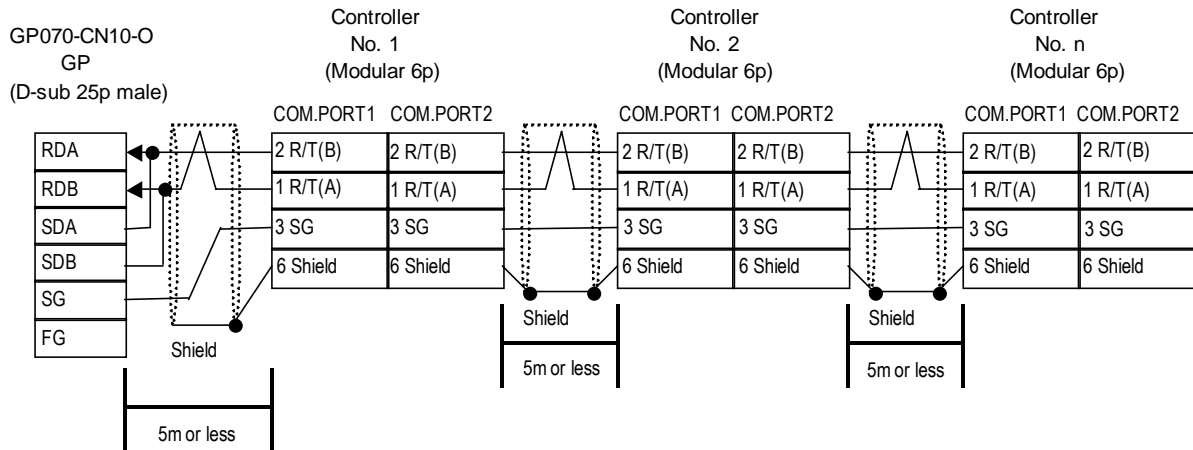

- **Termination resistance is not required.**
- **A maximum of 16 controllers can be connected to the GP unit.**

<When making your own cable>

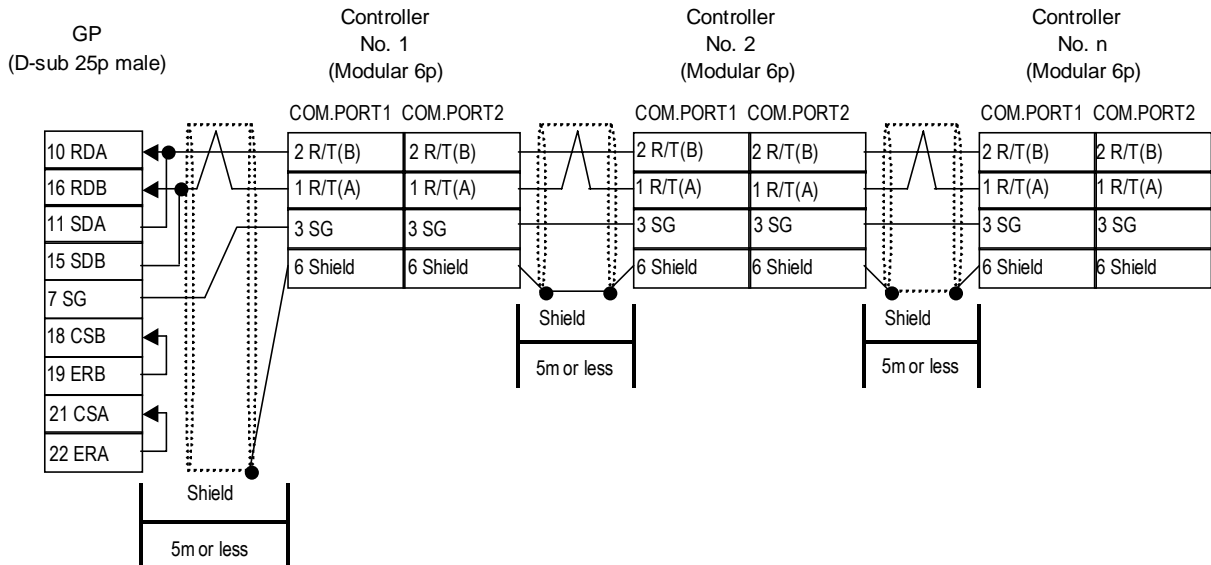

- **Termination resistance is not required.**
- **A maximum of 16 controllers can be connected to the GP unit.**

Cable Diagram 15 RS-232C

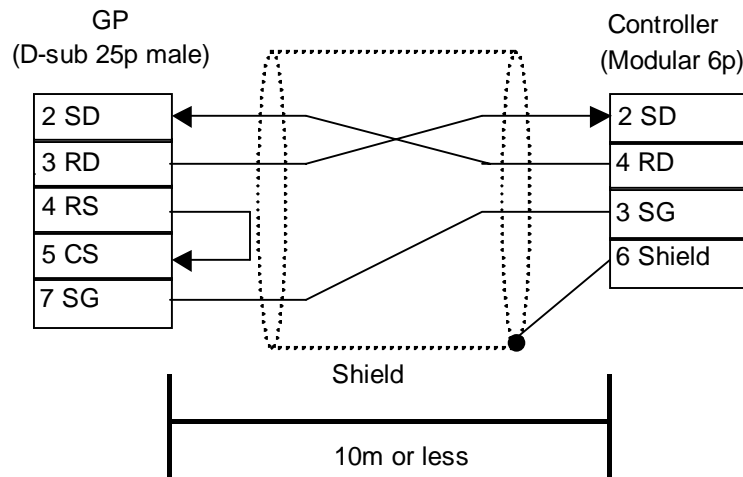

Cable Diagram 16 RS-422 4-wire

Signal Name	Terminal No.	
	MA900	HA900
SG	44	25
T(A)	45	26
T(B)	46	27
R(A)	47	28
R(B)	48	29

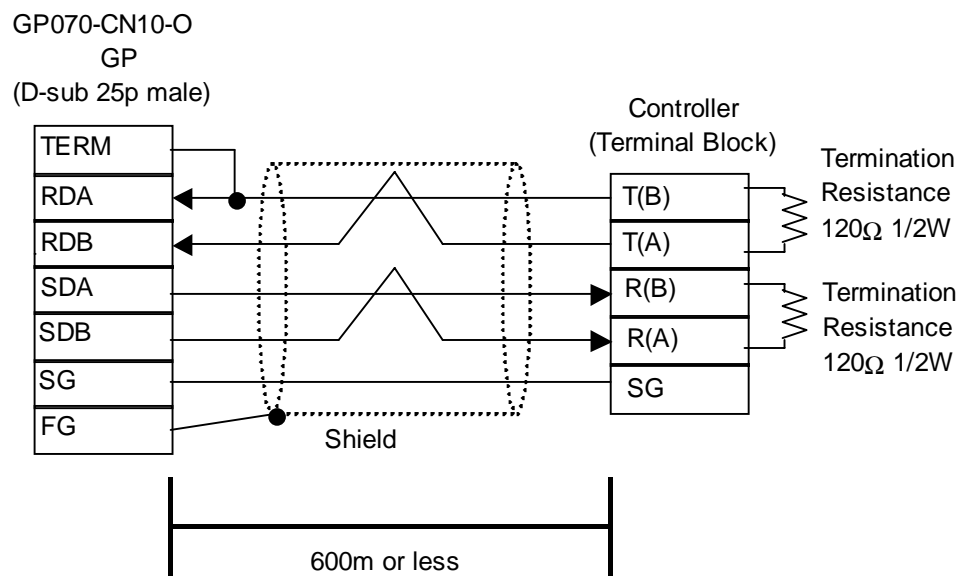

<When making your own cable>

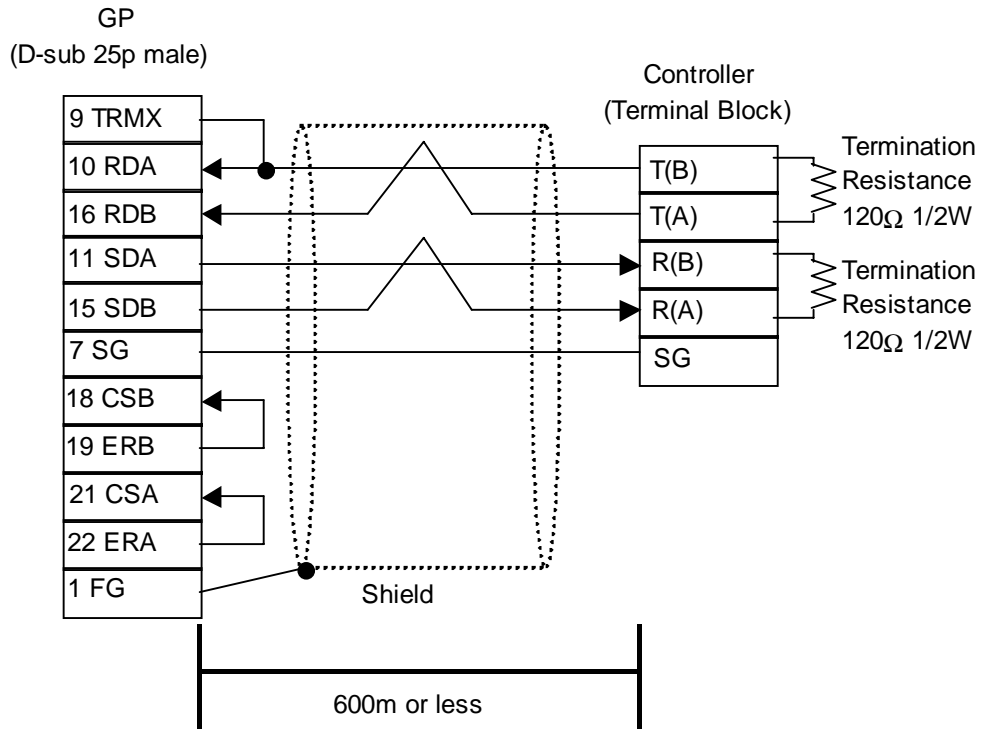

Cable Diagram 17 (1:n) RS-422 4-wire

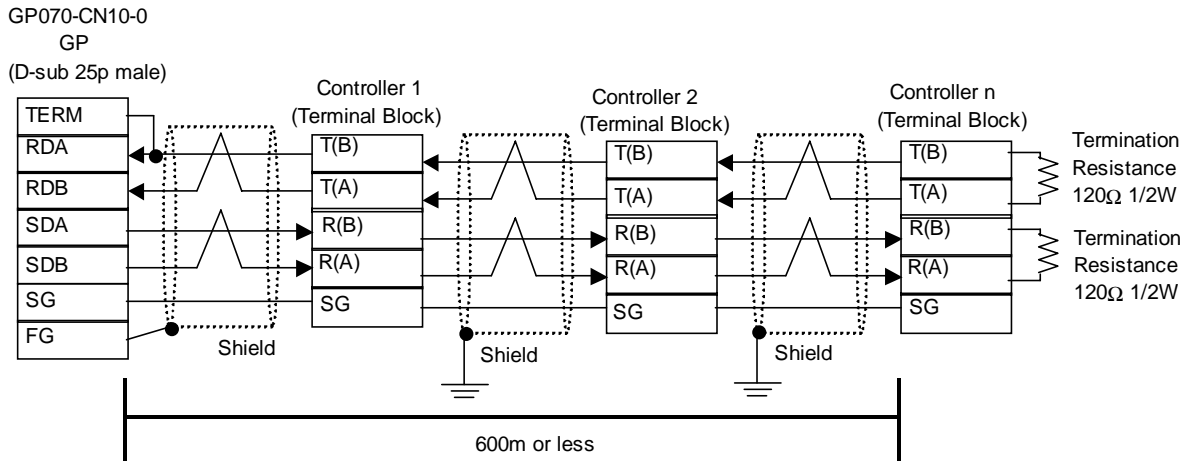

<When making your own cable>

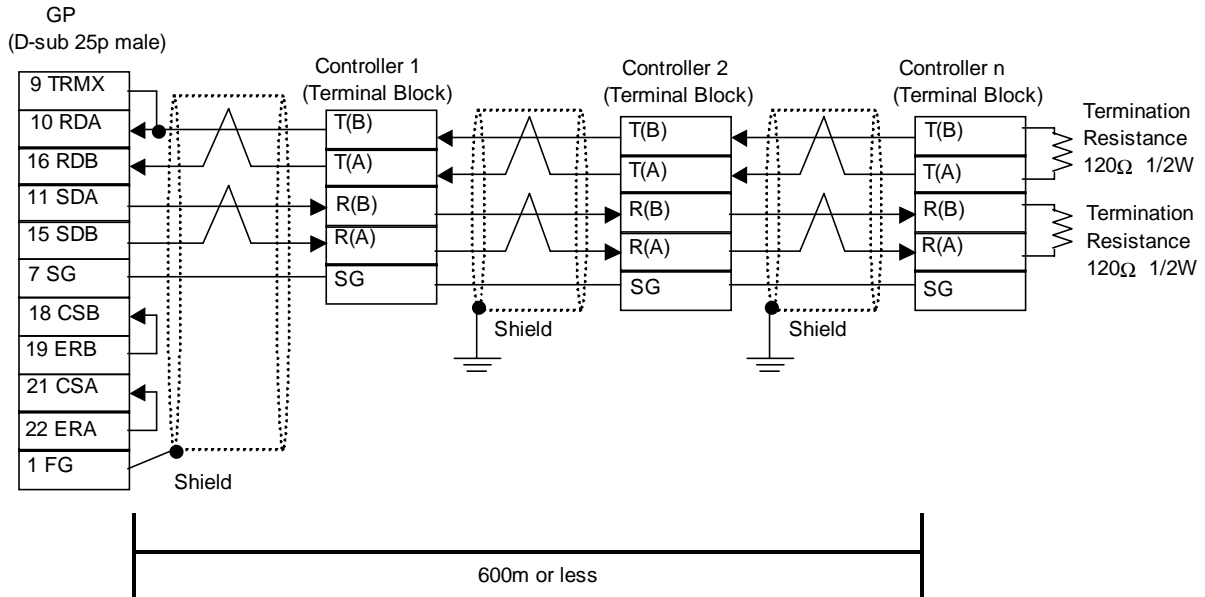

Cable Diagram 18 RS-422 2-Wire

Signal Name	Terminal No.		
	MA900	HA900	SA200
SG	44	25	10
T/R(A)	45	26	11
T/R(B)	46	27	12

GO070-CN10-O
GP
(D-sub 25p male)

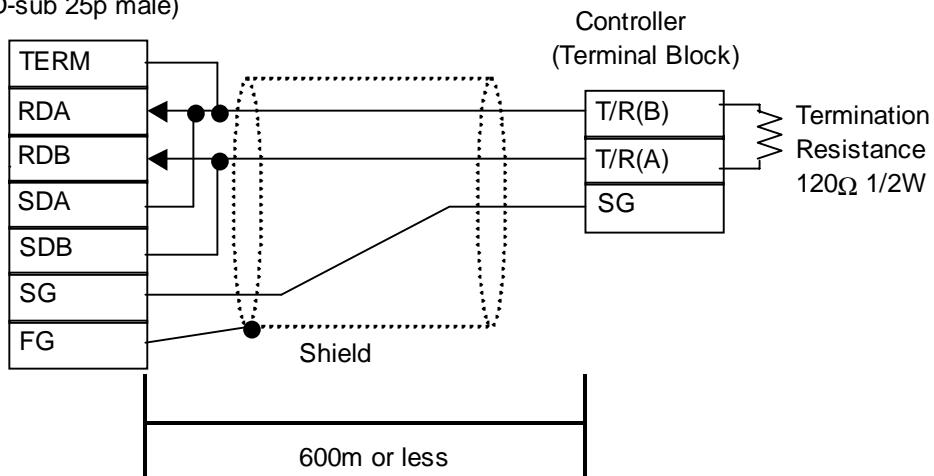

<When making your own cable>

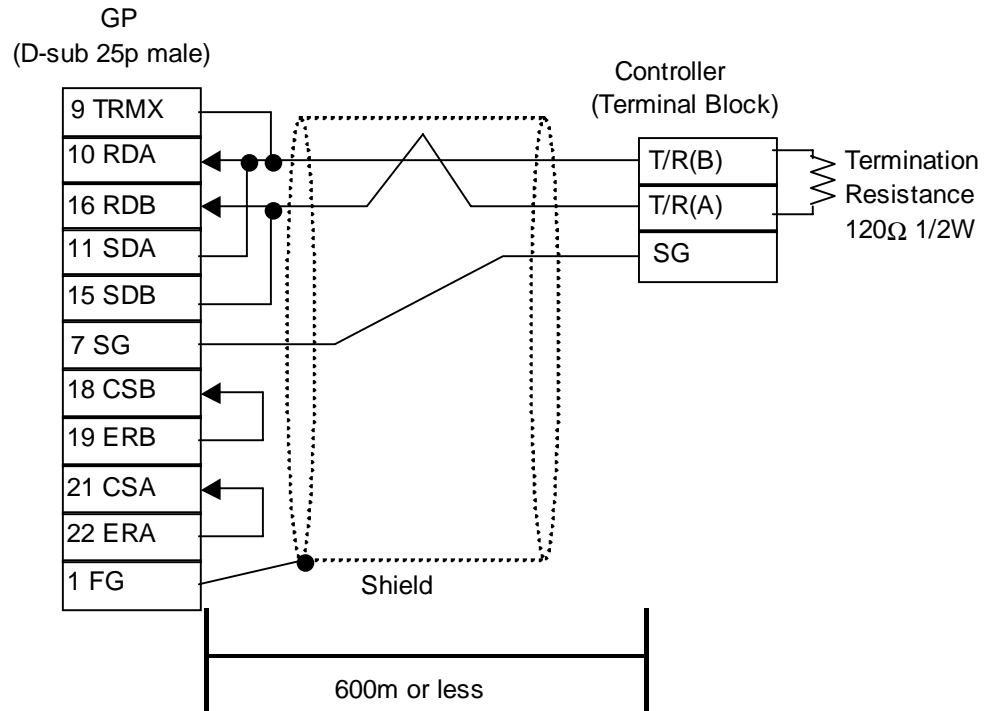

Cable Diagram 19 (1:n) RS-422 2-wire

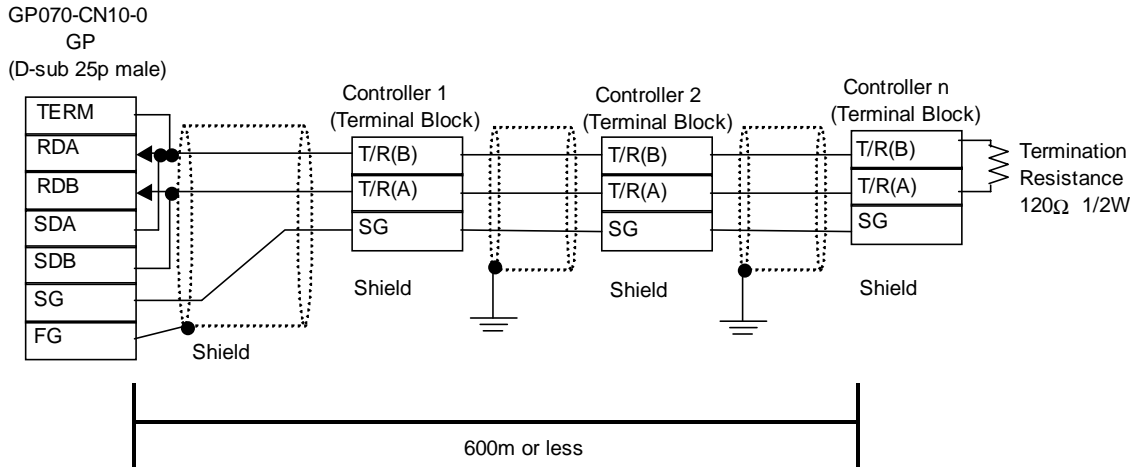

<When making your own cable>

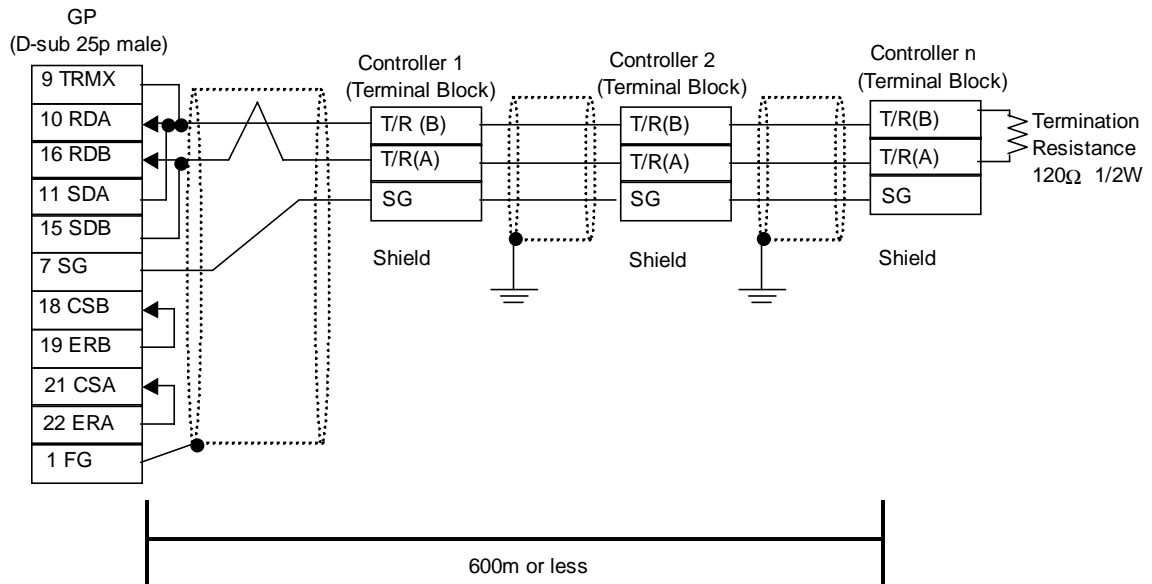

Cable Diagram 20 RS-232C

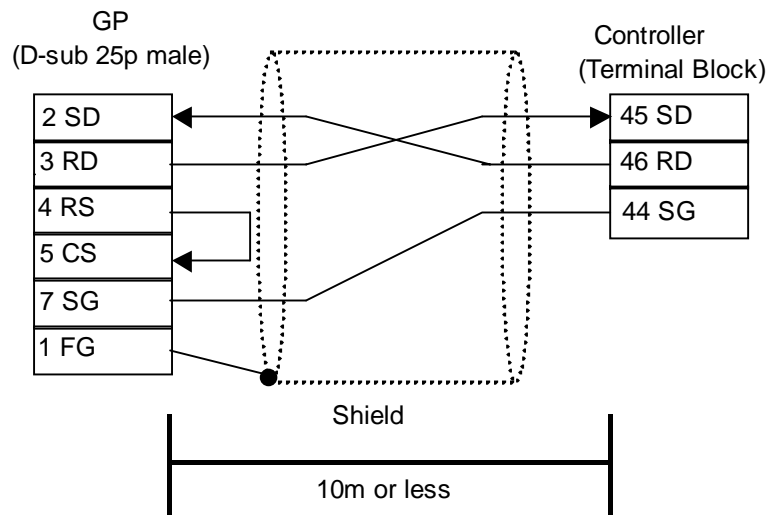

Cable Diagram 21 RS-422 2-Wire

<When using Digital's RS-422 connector terminal adapter GP070-CN10-O>

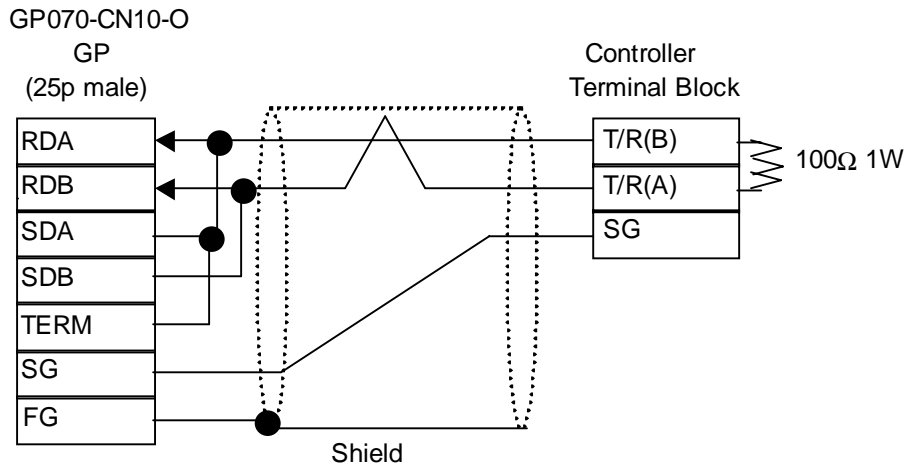

<When making your own cable>

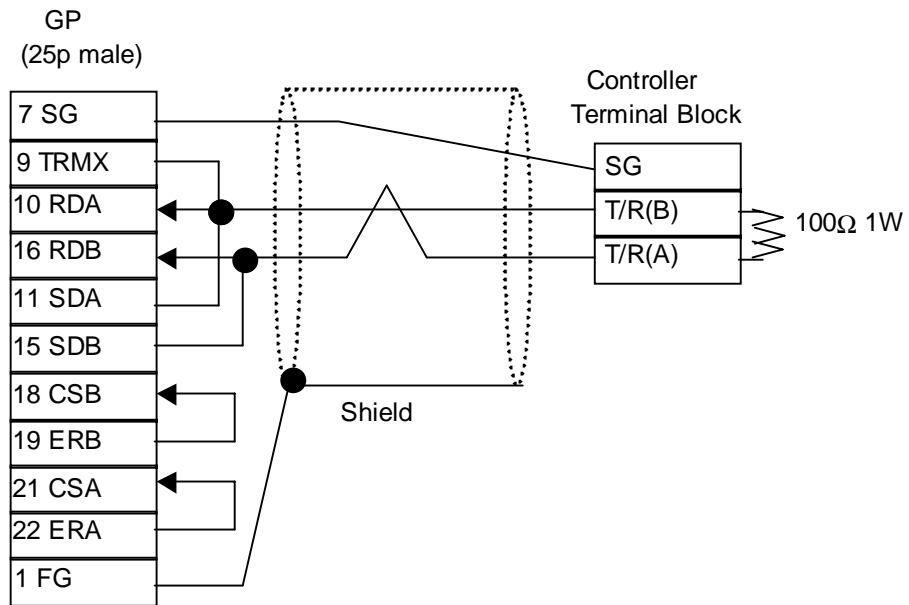

Cable Diagram 22 (1:n) RS-422 2-wire

<When using Digital's RS-422 connector terminal adapter GP070-CN10-O>

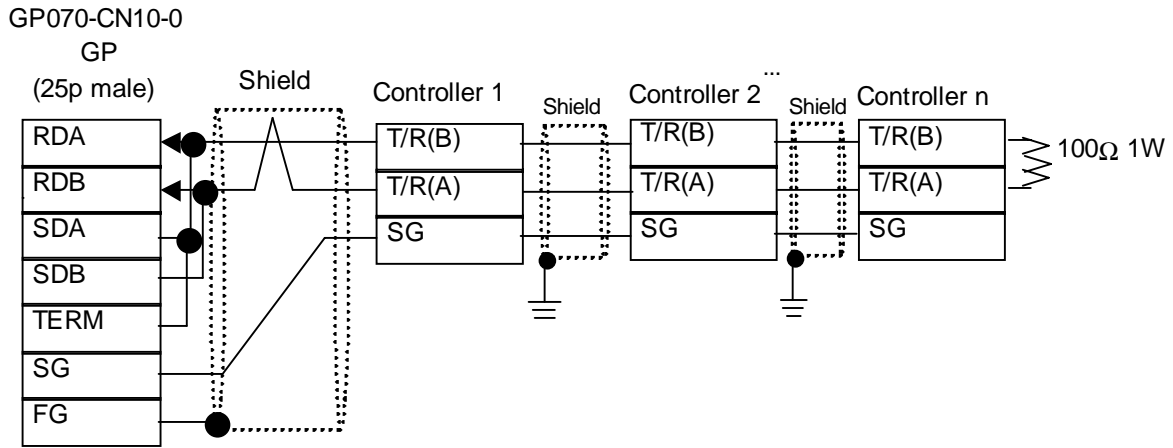

<When making your own cable>

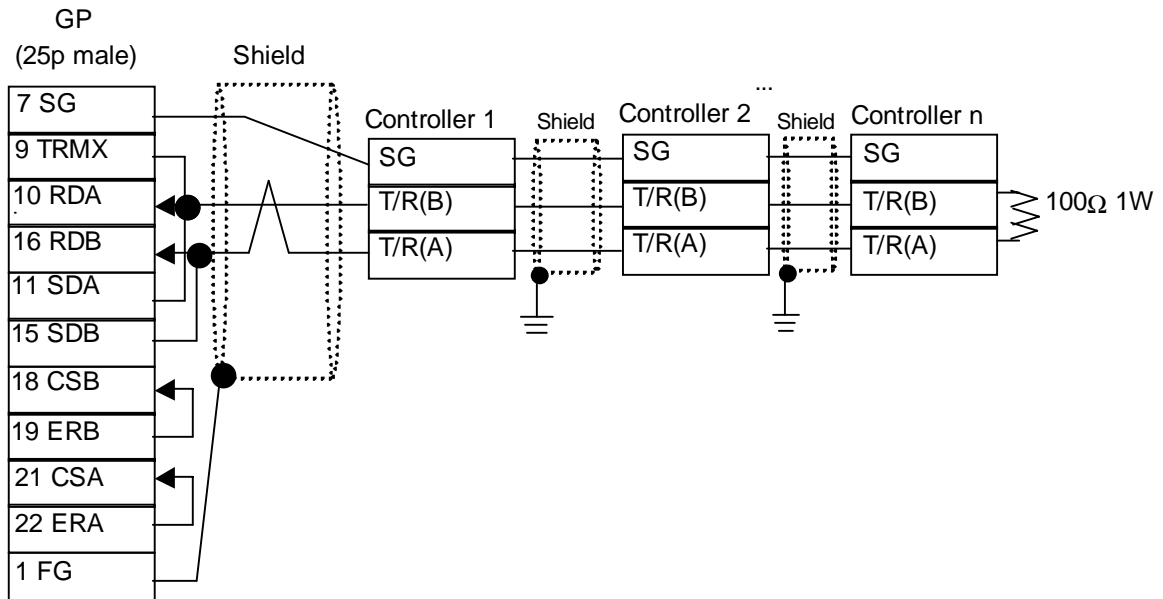

12.4.3 Supported Devices

The following list shows the range of devices supported by the GP/GLC/LT.

■ **CB Series / SR-Mini Series** (Modbus protocol)

Device	Bit Address	Word Address	Comments	
—	00000 ~ 02EEF	0000 ~ 02EE		L/H

■ **SR Mini HG Series** (Modbus protocol)

Device	Bit Address	Word Address	Comments	
—	00000 ~ 1DEEF	0000 ~ 1DEE		L/H

■ **MA900 Series** (Modbus protocol)

Device	Bit Address	Word Address	Comments	
—	00000 ~ 14A0F	0000 ~ 14A0		L/H

■ **HA900/HA400 Series** (Modbus protocol)

Device	Bit Address	Word Address	Comments	
—	00000 ~ 0535F	0000 ~ 0535	*1	L/H

*1 Two register addresses are used for one variable.

■ **SA200 Series** (Modbus protocol)

Device	Bit Address	Word Address	Comments	
—	00000 ~ 001EF	0000 ~ 001E		L/H

■ **SRX Series** (Modbus protocol)

Device	Bit Address	Word Address	Comments	
—	00000 ~ 03FFF	0000 ~ 03FF		L/H
	04000 ~ 07FFF	0400 ~ 07FF		
	08000 ~ 0883F	0800 ~ 0883		
	10000 ~ 13FFF	1000 ~ 13FF		
	14000 ~ 17FFF	1400 ~ 17FF		
	18000 ~ 1883F	1800 ~ 1883		

■ SRV Series (Modbus protocol)

Device	Bit Address	Word Address	Comments
—	00000 ~ 03FFF	0000 ~ 03FF	L/H
	08000 ~ 0881F	0800 ~ 0881	
	10000 ~ 13FFF	1000 ~ 13FF	
	18000 ~ 1881F	1800 ~ 1881	



• GP/GLC/LT's System Area (LS0 to LS19) Settings

The GP/GLC/LT's system area (20 words) cannot be allocated to the Controller's own data area. When you are entering the system area settings via the screen editor software or via the GP/GLC/LT's OFFLINE screen, be careful that you do not use the Controller's own data area.

- The data communication feature will not operate when the slave address No. is set to "0". (The default value is 0.)



Indicating Controller Slave Address settings can be entered in your screen editor software. If a station number is not indicated, the previously entered station number is automatically used. (The default value is 1.)

E.g. When entering Device Address 02EE

Enter the Device Name "...", and the Word Address "02EE".

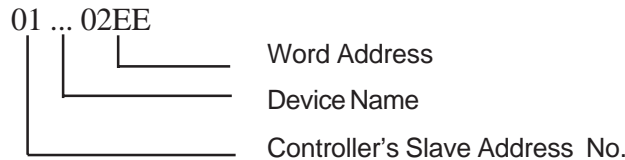

■ **CB Series** (RKC protocol)

Device	Bit Address	Word Address	Comments
CB	CB00000 ~ CB0036F	CB0000 ~ CB0036	L/H

■ **REX-F Series** (RKC protocol)

Device	Bit Address	Word Address	Comments
REX	REX00000 ~ REX0055F	REX0000 ~ REX0055	L/H

■ **LE100 Series** (RKC protocol)

Device	Bit Address	Word Address	Comments
LE	LE00000 ~ LE0070F	LE0000 ~ LE0070	L/H



• **GP/GLC/LTs System Area (LS0 to LS19) Settings**

The GP/GLC/LT's system area (20 words) cannot be allocated to the Controller's own data area. When you are entering the system area settings via the screen editor software or via the GP/GLC/LT's OFFLINE screen, be careful that you do not use the Controller's own data area.



Indicating Controller identifier data contains data to the right of the decimal point. This decimal point data is handled by the GP/GLC/LT as follows:

■ **When reading out data**

Data read out by the Indicating Controller is handled as integer data.

EX. With a value of 100.0:

Indicating Controller: 100.0
 GP/GLC/LT: 1000

When displaying decimal point data in a numeric display, use the [Display Data Format] area's [Decimal Places] setting. In this example, only the first decimal place is used, so this setting should be "1". Now, the data will be handled correctly.

EX. With a value of 100.0:

Indicating Controller: 100.0
 GP/GLC/LT: 100.0

Depending on the designated address, decimal point will be handled internally as follows:

When the Device List Address is designated with no changes:

no decimal point data is used

When 0x1000 is added to the Device List Address:

one (1) decimal point integer is used

When 0x2000 is added to the Device List Address:

two (2) decimal point integers are used

When 0x3000 is added to the Device List Address:

three (3) decimal point integers are used

Depending on the Address designation method used, the GP's data will be as follows:

Indicating Controller Data	GP/GLC/LT Data			
	No change to Address data	Adding 0x1000 to the Address	Adding 0x2000 to the Address	Adding 0x3000 to the Address
123	123	1230	12300	23000
123.4	123	1234	12340	23400
12.34	12	123	1234	12340
1.234	1	12	123	1234

If the address designation method and the Indicating Controller data's decimal point position are not the same, the address' decimal data will be either cut off or replaced with a "0".

When decimal data becomes larger than 6 digits, the left-most digit(s) will be cut.

EX. If "11223344" is used, the number will become "223344".

■ **When writing data**

When writing data to an Indicating Controller, data must be integers.

Depending on the designated address, the decimal point will be handled internally as follows:

When the Device List Address is designated with no changes:

no decimal point data is used

When 0x1000 is added to the Device List Address:

one (1) decimal point integer is used

When 0x2000 is added to the Device List Address:

two (2) decimal point integers are used

When 0x3000 is added to the Device List Address:

three (3) decimal point integers are used

EX. 1) When writing "100.0" to the CB Series unit's Alarm 1 Setting (A1)

GP/GLC/LT's address value: 0x1007

GP/GLC/LT's write value: 1000

EX. 2) When writing "100" to the CB Series unit's Alarm 1 Setting (A1)

GP/GLC/LT's address value: 0x0007

GP/GLC/LT's write value: 100

Depending on the Address designation method used, the Indicating Controller's write data will be as follows:

GP/GLC/LT Data	Indicating Controller Write Data			
	No change to Address data	Adding 0x1000 to the Address	Adding 0x2000 to the Address	Adding 0x3000 to the Address
1	1	0.1	0.01	0.001
123	123	12.3	1.23	0.123
1234	1234	123.4	12.34	1.234

If the address designation method and the Indicating Controller data's decimal point position are not the same, the address' decimal data will be either cut off or replaced with "0".



- Please refer to your RKC Instrument Inc. Indicating Controller installation guide for information about identifier data setting ranges and decimal point positions.
- Indicating Controller device address settings can be entered in your screen editor software. If a device address is not indicated, the previously entered device address is automatically used. (The default value is 0.)

<Example of device settings>

■ Communication identifier list (CB Series)

Address	Identifier	Description
00	M1	Measured value (PV)
01	M2	Current transformer input 1
02	M3	Current transformer input 2
03	AA	Alarm 1 status
04	AB	Alarm 2 status
05	B1	Burnout
06	S1	Set value (SV)
07	A1	Alarm 1 setting
08	A2	Alarm 2 setting
09	A3	Heater break alarm 1 setting
0A	A4	Heater break alarm 2 setting
0B	A5	Control loop break alarm setting
0C	A6	LBA deadband
0D	G1	Autotuning (AT)
0E	G2	Self-tuning (ST)
0F	P1	Heat-side proportional band
10	I1	Integral time
11	D1	Derivative time
12	W1	Anti-reset windup
13	T0	Heat-side proportional cycle
14	P2	Cold-side proportional band
15	V1	Deadband
16	T1	Cold-side proportional cycle
17	PB	PV bias
18	LK	Set data lock function
19	SR	RUN/STOP function
1A	ER	Error code
1B	IO	Initialization mode selection
1C	IP	Setting necessary code [Cod]
1D	XI	Input type selection [SL1]
1E	XQ	Engineering unit and cooling type selection [SL2]
1F	LV	Heater break alarm (HBA), control loop break alarm (LBA), special specification, or control loop break alarm (LBA) output selection [SL3]

Address	Identifier	Description
20	XA	First alarm (ALM1) type or First alarm (ALM1) with hold action selection [SL4]
21	XB	Second alarm (ALM2) type or Second alarm (ALM2) with hold action selection [SL5]
22	CA	Control action type selection [SL6]
23	Z1	Energized/de-energized alarm selection, special specification selection 1 [SL7]
24	Z2	Special specification selection 2 [SL8]
25	Z3	Special specification selection 3 [SL9]
26	DH	Option selection [SL10]
27	XC	SV alarm type selection [SL11]
28	XV	Setting limiter (high limit) [SLH]
29	XW	Setting limiter (low limit) [SLL]
2A	XU	Setting the position of decimal point [PGdP]
2B	MH	Differential gap setting of ON/OFF action [oH]
2C	HA	Differential gap setting of first alarm (ALM1) [AH1]
2D	HB	Differential gap setting of second alarm (ALM2) [AH2]
2E	XR	CT ratio setting [CTr]
2F	F1	Digital filter setting [dF]
30	GH	Time factor assumed to be safe [STTM]
31	PU	Factor to calculate proportional band [STPK]
32	IU	Factor to calculate integral time [STIK]
33	IL	Integral time limiter [ILIM]
34	HP	Holding peak ambient temperature [TCJ]
35	UT	Operating time display unit (Upper digits) [WTH]
36	UU	Operating time display unit (Lower digits) [WTL]

■ Communication identifier list (REX-F Series)

Address	Identifier	Description
00	M1	Measured-value (PV) input
01	AA	First alarm output
02	AB	Second alarm output
03	AC	Heater break alarm output
04	O1	Manipulated output (Heating-side)
05	O2	Manipulated output (Cooling-side)
06	B1	Burnout
07	B2	Feedback resistance (FBR) input burnout
08	S2	Remote setting value (RS)
09	M2	Feedback resistance input value (POS)
0A	M3	Current transformer input value
0B	MS	Set-value (SV) monitoring
0C	J1	Auto/manual transfer
0D	C1	Local/remote transfer
0E	E1	Local/external memory area transfer
0F	ZA	Control area No. transfer
10	G1	PID control/auto-tuning transfer
11	RA	Local mode/computer mode identification
12	SR	Operation execution (RUN)/STOP transfer
13	ON	Manipulated output value (MV)
14	S1	Set-value (SV)
15	A1	First alarm setting
16	A2	Second alarm setting
17	P1	Proportional band (Heating-side)
18	I1	Integral time
19	D1	Derivative time
1A	CA	Control response designation parameter
1B	P2	Cooling-side proportional band
1C	V1	Deadband
1D	HH	Setting change rate limit
1E	PB	PV bias
1F	F1	PV digital filter
20	DP	PV low input cut-off
21	RR	RS ratio
22	RB	RS bias
23	F2	RS digital filter
24	OH	Output limit (High limit)
25	OL	Output limit (Low limit)
26	OQ	Cooling output Min. ON time
27	PH	Increase in output change rate limit
28	PL	Decrease in output change rate limit

Address	Identifier	Description
29	IV	Upper ON/OFF action (A) differential gap
2A	IW	Lower ON/OFF action (A) differential gap
2B	OE	Manual output at abnormality
2C	GB	AT bias
2D	HA	First alarm differential gap
2E	TD	First alarm timer setting
2F	A3	Heater break alarm
30	HB	Second alarm differential gap
31	TG	Second alarm timer setting
32	LA	Analog output (AO) Specification selection
33	HV	Analog output (AO) Scale high limit
34	HW	Analog output (AO) Scale low limit
35	V2	Neutral zone
36	VH	Open/close output differential gap
37	SY	Action selection at feedback resistance (FBR) input break
38	DA	Bar-graph display selection
39	XI	PV input type selection
3A	AV	Input abnormality determination point (High limit)
3B	AW	Input abnormality determination point (Low limit)
3C	WH	Action selection at input abnormality (High limit)
3D	WL	Action selection at input abnormality (Low limit)
3E	XV	Input programmable range (High limit)
3F	XW	Input programmable range (Low limit)
40	XU	Decimal-point position selection
41	XH	Square root extraction selection
42	SH	Setting limit (High limit)
43	SL	Setting limit (Low limit)
44	XR	RS input type selection
45	XL	SV tracking selection
46	T0	Proportioning cycle (Heating-side)
47	T1	Cooling-side proportioning cycle
48	XE	Direct/reverse action selection
49	XN	Hot/cold start selection
4A	SX	Start determination point
4B	XA	First alarm Action selection
4C	NA	First alarm Energized/de-energized selection
4D	OA	First alarm Action selection at input abnormality
4E	WA	First alarm Hold action selection
4F	XB	Second alarm Action selection

Address	Identifier	Description
50	NB	Second alarm Energized/de-energized selection
51	OB	Second alarm Action selection at input abnormality
52	WB	Second alarm Hold action selection
53	LK	Set data lock level
54	LL	Area lock
55	DH	Operation RUN/STOP display lock

■ Communication identifier list (LE100 Series)

Address	Identifier	Description
0	M1	Measured value (PV)
1	AA	Output 1 status
2	AB	Output 2 status
3	AC	Output 3 status
4	AD	Output 4 status
5	AE	Output 5 status
6	AF	Output 6 status
7	AG	Output 7 status
8	AH	Output 8 status
9	B1	Burnout
0A	ER	Error code
0B~0D	ID	ID data
0E	MS	Specific gravity monitor
0F	ML	Scale low monitor
10	MH	Scale high monitor
11	HP	Peak hold monitor
12	HQ	Bottom hold monitor
13	MW	Number of wafer processing times monitor
14	MZ	Amount of emptiness correction monitor
15	A1	Output 1 set value
16	A2	Output 2 set value
17	A3	Output 3 set value
18	A4	Output 4 set value
19	A5	Output 5 set value
1A	A6	Output 6 set value
1B	A7	Output 7 set value
1C	A8	Output 8 set value
1D	A9	Actual liquid output setting
1E	AZ	Emptiness adjustment
1F	WT	Number of wafer processing times
20	CW	Initializing the number of wafer processing times
21	HR	Hold reset
22	IR	Interlock release
23	LK	Set data lock
24	IS	Default setting
25	EC	Error release
26	LU	Decimal point position selection
27	LT	Number of linearizing table setting

Address	Identifier	Description
28	L0	Linearizing table setting 0
29	L1	Linearizing table setting 1
2A	L2	Linearizing table setting 2
2B	L3	Linearizing table setting 3
2C	L4	Linearizing table setting 4
2D	L5	Linearizing table setting 5
2E	L6	Linearizing table setting 6
2F	L7	Linearizing table setting 7
30	L8	Linearizing table setting 8
31	L9	Linearizing table setting 9
32	LA	Linearizing table setting 10
33	F1	Digital filter
34	XA	Output 1 type selection
35	DA	Output 1 deviation value setting
36	QA	Output 1 interlocking function selection
37	NA	Output 1 a/b contact selection
38	HA	Output 1 differential gap
39	TA	Output 1 timer setting
3A	XB	Output 2 type selection
3B	DB	Output 2 deviation value setting
3C	QB	Output 2 interlocking function selection
3D	NB	Output 2 a/b contact selection
3E	HB	Output 2 differential gap
3F	TB	Output 2 timer setting
40	XC	Output 3 type selection
41	DC	Output 3 deviation value setting
42	QC	Output 3 interlocking function selection
43	NC	Output 3 a/b contact selection
44	HC	Output 3 differential gap
45	TC	Output 3 timer setting
46	XD	Output 4 type selection
47	DD	Output 4 deviation value setting
48	QD	Output 4 interlocking function selection
49	ND	Output 4 a/b contact selection
4A	HD	Output 4 differential gap
4B	TD	Output 4 timer setting
4C	XE	Output 5 type selection
4D	DE	Output 5 deviation value setting
4E	QE	Output 5 interlocking function selection
4F	NE	Output 5 a/b contact selection
50	HE	Output 5 differential gap
51	TE	Output 5 timer setting

Address	Identifier	Description
52	XF	Output 6 type selection
53	DF	Output 6 deviation value setting
54	QF	Output 6 interlocking function selection
55	NF	Output 6 a/b contact selection
56	HF	Output 6 differential gap
57	TF	Output 6 timer setting
58	XG	Output 7 type selection
59	DG	Output 7 deviation value setting
5A	QG	Output 7 interlocking function selection
5B	NG	Output 7 a/b contact selection
5C	HG	Output 7 differential gap
5D	TG	Output 7 timer setting
5E	XH	Output 8 type selection
5F	DH	Output 8 deviation value setting
60	QH	Output 8 interlocking function selection
61	NH	Output 8 a/b contact selection
62	HH	Output 8 differential gap
63	TH	Output 8 timer setting
64	HV	Monitor output high
65	HW	Monitor output low
66	EG	End specific gravity setting
67	SW	Number of wafer processing times setting
68	XX	Scale low
69	SG	Specific gravity setting
6A	J1	Scale 1 actual liquid setting
6B	J2	Scale 2 actual liquid setting
6C	J3	Correction on the low limit side by actual liquid 2
6D	J4	Correction on the high limit side by actual liquid 2
6E	UN	Unit setting
6F	SP	Specific gravity setting transfer
70	SS	Specific gravity correction function selection
71	DS	DI function selection
72	MM	Volume/level display selection



When you register an identifier as a symbol, you can then select that identifier when setting up addresses. Installing the screen editor software will copy the sample symbol file of addresses registered for Unit No. 0 to the folder named "Sample". When designating a default folder, be sure to specify "C:\Program Files\Pro-face\ProPBWin\Sample". This sample file can be imported using the Symbol Editor. For information on how to use the Import feature, please refer to your screen editor's Operation Manual.

- Symbol File : RKCsymbol.lbe

After importing the symbol file, a pull-down list of registered symbols (identifiers) will appear when you click on the black triangle. (see below)

The screenshot shows a software interface with a 'Word Address' field containing 'CB_M1'. A pull-down menu is open, displaying a list of identifiers and their corresponding addresses. The list includes: CB_M1 - 00/CB0000, CB_M1 - 00/CB0001, CB_M3 - 00/CB0002, CB_AA - 00/CB0003, CB_AB - 00/CB0004, CB_B1 - 00/CB0005, and CB_S1 - 00/CB0006. Above the interface, the text 'CB_M1' is shown with a bracket pointing to the pull-down menu, labeled 'Identifier'. To the right, a legend defines the series names: 'CB :CB Series', 'REX :REX-F Series', and 'LE :LE100 Series'. The interface also shows buttons for 'play Format', 'Shape/Color', and 'Alarm Settings'.

* When using Sta. No. other than the sample file's Sta. No. 0, be sure to change the sample file's Sta. No. data.

12.4.4 Environment Setup

The following table lists Digital's recommended RKC INSTRUMENT INC. Controller and GP/GLC/LT communication settings.

■ **CB Series (Modbus protocol)**

GP/GLC/LT Settings		Controller Settings	
Baud Rate	9600bps	Baud Rate	9600bps
Data Length	7bits	Data Length	7bits
Stop Bit	2bits	Stop Bit	2bits
Parity Bit	odd	Parity Bit	odd
Data Flow Control	ER(Fixed)	_____	_____
Communication Format When using RS-422	RS-422(2-wire)	_____	_____
Unit No.	1~32	Slave Address	1~32



- **The controller's slave address number range is from 0 to 99 for CB Series units (The data communication feature does not operate when it is set to "0"). Use only from 1 to 32 on the GP/GLC/LT.**
- **With a 1:n connection, up to 31 CB Series units can be connected to a single GP/GLC/LT.**

■ **SR-Mini Series (Modbus protocol)**

GP/GLC/LT Settings		Controller Settings	
Baud Rate	9600bps	Baud Rate	9600bps
Data Length	8bits	Data Length	8bits
Stop Bit	1bit	Stop Bit	1bit
Parity Bit	None	Parity Bit	None
Data Flow Control	ER(fixed)	_____	_____
Communication Format When using RS-232C	RS-232C	_____	_____
Communication Format When using RS-422	RS-422(4-wire)	_____	_____
Unit No.	1~16	Slave Address	1~16



- **The controller's slave address number range is from 1 to 16 for SR-Mini Series units (The data communication feature does not operate when it is set to "0"). Use only from 1 to 16 on the GP/GLC/LT.**
- **With a 1:n connection, up to 16 SR-Mini Series units can be connected to a single GP/GLC/LT.**

■ **SR Mini HG Series** (Modbus protocol)

GP/GLC/LT Settings		Controller Settings	
Baud Rate	9600bps	Baud Rate	9600bps
Data Length	8bits	Data Length	8bits
Stop Bit	1bit	Stop Bit	1bit
Parity Bit	None	Parity Bit	None
Data Flow Control	ER	_____	_____
Communication Format *1	RS-422(4-wire)	_____	_____
	RS-232C		_____
Unit No.	1~16	Slave Address *2	1~16
_____	_____	Communication Protocol	MODBUS protocol

*1 The communication format varies depending on the controller model.

*2 The slave address is calculated by adding 1 to the unit address. Therefore, an unit address of 0 results in a slave address of 1.

■ **MA900 Series** (Modbus protocol)

GP/GLC/LT Settings		Controller Settings	
Baud Rate	9600bps	Baud Rate	9600bps
Data Length	8bits	Data Length	8bits
Stop Bit	1bit	Stop Bit	1bit
Parity Bit	None	Parity Bit	None
Data Flow Control	ER	_____	_____
Communication Format *1	RS-232C	_____	_____
	RS-422(4-wire)		_____
	RS-422(2-wire)		_____
Unit No.	1~32	Slave Address *2	1~32

*1 The communication format varies depending on the controller model.

*2 The Controller's slave address range is from 0 to 99 for MA900 Series units. Use only from 1 to 32 on the GP. Depending on MA900 Series unit specifications, the data communication feature does not operate when the slave address is set to "0".

■ HA900/HA400 Series (Modbus protocol)

GP/GLC/LT Settings		Controller Settings	
Baud Rate	9600bps	Baud rate	9600bps
Data Length	8bits	Data Length	8bits
Stop Bit	1bit	Stop Bit	1bit
Parity Bit	None	Parity Bit	None
Data Flow Control	ER	_____	_____
Communication Format *1	RS-232C	_____	_____
	RS-422(4-wire)		_____
	RS-422(2-wire)		_____
Unit No.	1~32	Slave Address *2	1~32

*1 The communication format varies depending on the controller model.

*2 The Controller's slave address range is from 0 to 99 for HA900 Series units. Use only from 1 to 32 on the GP. Depending on HA900 Series unit specifications, the data communication feature does not operate when the slave address is set to "0".

■ SA200 Series (Modbus protocol)

GP/GLC/LT Settings		Controller Settings	
Baud Rate	9600bps	Baud Rate	9600bps
Data Length	8bits	Data Length	8bits
Stop Bit	1bit	Stop Bit	1bit
Parity Bit	None	Parity Bit	None
Data Flow Control	ER	_____	_____
Communication Format	RS-422(2-wire)	_____	_____
Unit No.	1~32	Slave Address *1	1~32

*1 The controller's slave address range is from 0 to 99 for SA200 Series units. Use only from 1 to 32 on the GP. Depending on SA200 Series unit specifications, the data communication feature does not operate when the slave address is set to "0".

■ **SRX Series / SRV Series** (Modbus protocol)

GP/GLC/LT Settings		Controller Settings	
Baud rate	9600bps	Baud Rate	9600bps
Data Length	8bits	Data Length	8bits(Fixed)
Stop Bit	1bit	_____	
Parity Bit	None	Designates Parity	None
Data Flow Control	ER	_____	
Communication Format	2-wire	_____	
Unit No.	1~32	Slave Address *1	1~32
_____		Communication Protocol	MODBUS

*1 The slave address is calculated by adding 1 to the module address.

The controller's slave address range is from 0 to 99 for SRX Series / SRV Series units.
Use only from 1 to 32 on the GP.

■ **CB Series** (RKC protocol)

GP/GLC/LT Settings		Controller Settings	
Baud Rate	9600bps	Baud Rate	9600bps
Data Length	8bits	Data Length	8bits
Stop Bit	1bit	Stop Bit	1bit
Parity Bit	None	Parity Bit	None
Data Flow Control	ER(fixed)	_____	_____
Communication Format When using RS-422	RS-422(2-wire)	_____	_____
Unit No.	0~31	Device Address	0~31



- The controller's device address number range is from 0 to 99 for the CB Series units. Use only from 0 to 31 on the GP/GLC/LT.
- With a 1:n connection, up to 31 CB Series units can be connected to a single GP/GLC/LT.

■ **REX-F Series (RKC protocol)**

GP/GLC/LT Settings		Controller Settings	
Baud Rate	9600bps	Baud Rate	9600bps
Data Length	7bits	DataLength	7bits
Stop Bit	2bits	Stop Bit	2bits
Parity Bit	odd	Parity Bit	odd
Data Flow Control	ER(Fixed)	_____	_____
Communication Format When using RS-232C	RS-232C	_____	_____
Communication Format When using RS-422	RS-422(4-wire)	_____	_____
	RS-422(2-wire)	_____	_____
Unit No.	0~31	Device Address	0~31



- **The controller's device address number range is from 0 to 99 for the REX-F Series units. Use only from 0 to 31 on the GP/GLC/LT.**
- **With a 1:n connection, up to 31 REX-F Series units can be connected to a single GP/GLC/LT.**

■ **LE100 Series (RKC protocol)**

GP/GLC/LT Settings		Controller Settings	
Baud Rate	9600bps	Baud Rate	9600bps
Data Length	8bits	Data Length	8bits
Stop Bit	1bit	Stop Bit	1bit
Parity Bit	None	Parity Bit	None
Data Flow Control	ER(fixed)	_____	_____
Communication Format When using RS-422	RS-422(2-wire)	_____	_____
Unit No.	0~31	Device Address	0~31



- **The controller's device address number range is from 0 to 99 for the LE100 Series units. Use only from 0 to 31 on the GP/GLC/LT.**
- **With a 1:n connection, up to 31 LE100 Series units can be connected to a single GP/GLC/LT.**

12.4.5 Error Codes

■ Controller Error Codes

Error messages (Ex. Host communication error (02:**:##)) are displayed in the lower left corner of the GP/GLC/LT screen (** stands for an error code specific to the Controller).

Host Communication Error (02:**:##)

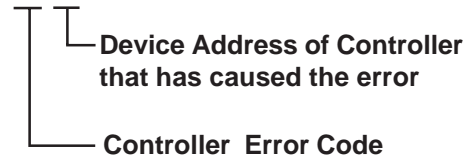

Error Code	Description
04	Occurs when a read out is performed from an address that cannot be read from.
15	Occurs when writing setting values that are outside of the allowed range.