

# Device/PLC Connection Manuals

---



## About the Device/PLC Connection Manuals

Prior to reading these manuals and setting up your device, be sure to read the "Important: Prior to reading the Device/PLC Connection manual" information. Also, be sure to download the "Preface for Trademark Rights, List of Units Supported, How to Read Manuals and Documentation Conventions" PDF file. Furthermore, be sure to keep all manual-related data in a safe, easy-to-find location.





## 2.1 Mitsubishi Electric

### 2.1.1 System Structure



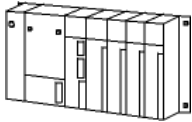

The following describes the system structure for connecting the GP to Mitsubishi Electric PLCs.

**Reference** *The Cable Diagrams mentioned in the following tables are listed in the section titled "2.1.2 Cable Diagrams".*

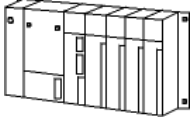

#### ■ MELSEC-A Series (using Link I/F)

CPU	Link I/F	Cable Diagram	Cables	Target Machine
	 Computer Link Unit			
A2A,A3A,A2U, A3U,A4U	AJ71C24-S6 AJ71C24-S8 AJ71UC24	RS-232C <Connection Diagram 1 >	GP410-IS00-0(5m)	GP/GLC Series
			CA3-CBL232/5M-01 (5m)	ST401/ST403
		RS-422 <Connection Diagram 2 >	GP230-IS11-0(5m)	GP/GLC Series
			CA3-CBL422/5M-01 (5m)	ST400/ST403
A2US	A1SJ71C24-R2, A1SJ71UC24-R2	RS-232C <Connection Diagram 3>	GP000-IS02-MS(3m)	GP/GLC Series
			—————	ST401/ST403
	A1SJ71UC24-R4	RS-422 <Connection Diagram 2>	GP230-IS11-0(5m)	GP/GLC Series
			CA3-CBL422/5M-01 (5m)	ST400/ST403
A2USH-S1	A1SJ71UC24-R4	RS-422 <Connection Diagram 2>	GP230-IS11-0(5m)	GP/GLC Series
			CA3-CBL422/5M-01 (5m)	ST400/ST403
	A1SJ71UC24-R2	RS-232C <Connection Diagram 3>	GP000-IS02-MS(3m)	GP/GLC Series
			—————	ST401/ST403

■ MELSEC-N Series (using Link I/F)

CPU	Link I/F	Cable Diagram	Cables	Target Machine	
	 Computer Link Unit				
A1N, A2N, A3N	AJ71C24, AJ71C24-S3, AJ71C24-S6, AJ71C24-S8, AJ71UC24 (A2N only)	RS-232C <Cable Diagram 1>	GP410-IS00-O (5m)	GP/GLC Series	
			CA3-CBL232/5M-01 (5m)	ST401/ST403	
	A0J2, A0J2H	A0J2-C214-S1	RS-422 <Cable Diagram 2>	GP230-IS11-0(5m)	GP/GLC Series
				CA3-CBL422/5M-01 (5m)	ST400/ST403
A1S	A1SJ71C24-R2, A1SJ71UC24-R2	RS-232C <Cable Diagram 3>	GP000-IS02-MS (3m)	GP/GLC Series	
			—————	ST401/ST403	
	A1SJ71C24-R4	RS-422 <Cable Diagram 2>	GP230-IS11-0(5m)	GP/GLC Series	
A1SJ, A2SH, A1SH	A1SJ71UC24-R4		CA3-CBL422/5M-01 (5m)	ST400/ST403	
	A1SJ71UC24-R2	RS-232C <Cable Diagram 3>	GP000-IS02-MS (3m)	GP/GLC Series	
—————			ST401/ST403		
A2CCPU24	Link unit on CPU	RS-232C <Cable Diagram 3>	GP000-IS02-MS (3m)	GP/GLC Series	
			—————	ST401/ST403	

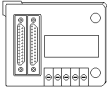
## MELSEC-A Series (CPU Direct Connection)

CPU <sup>*1</sup>	Adaptor	Cable Diagram	Cables	Target Machine
				
A2A,A3A,A4U,A3U, A2U-S1,A2US-S1, A2USH-S1,A2US		RS-422 <Cable Diagram 11> <sup>*4</sup>	A-Series Programing Console I/F Cable (isolation type) GP430-IP10-O (5m) <sup>*5*6</sup> GP2000-CBLA/5M- 01(5m) <sup>*7</sup>	GP/GLC Series
			CA3-CBLA-01(5m) <sup>*8</sup>	ST400/ST403
		Diatrend Cable DAFXIH-CABV <sup>*6</sup>	ST401/ST403	
A2A,A3A,A4U,A3U, A2U-S1,A2US-S1, A2USH-S1,A2US	2-Port Adaptor <sup>*2</sup> GP030-MD11-O	RS-422 (Refer to Mitsubishi's A Series PLC Manual "2 Port Adaptor" for cable diagram info.)	A-Series Programing Console I/F Cable (isolation type) GP430-IP10-O (5m) <sup>*5*6</sup>	GP/GLC Series
A2A,A3A,A4U, A2U-S1, A2USH-S1, A2US	2 Port Adaptor II <sup>*3</sup> GP070-MD11	RS-422 (Refer to Mitsubishi's A Series PLC Manual "2 Port AdapterII" for cable diagram info.)	GP070-MDCB11(5m) cable or user-created RS-422Cable	GP/GLC Series
		Refer to "Connecting a Device/PLC to the ST unit." page 1-6 "2-Port Adaptor II"	—————	ST400/ST403
	Mitsubishi's I/F unit FX-2PIF Refer to Mitsubishi's manual	RS-422 <Cable Diagram 11> <sup>*4</sup>	A-Series Programing Console I/F Cable (isolation type) GP430-IP10-O (5m) <sup>*5*6</sup> GP2000-CBLA/5M- 01(5m) <sup>*7</sup>	GP/GLC Series
			CA3-CBLA-01(5m) <sup>*8</sup>	ST400/ST403
			Diatrend Cable DAFXIH-CABV <sup>*6</sup>	ST401/ST403

\*1 Connect to the Programming Console I/F port.

\*2 When a Read/Write command is sent from ladder software while data is being transmitted between the PLC and the GP, there is a possibility the data transmission will not be completed normally.  
In that case, change the GP to OFFLINE mode and perform the read and write processing.



**If CPU direct connection with any CPUs that are not on the above list, the PLC can be damaged.**

**When the PLC unit has 2 ports, both cannot be connected with a GP at the same time.**

\*3 When using 2 Port Adapter II, refer to its manual for the connectable PLCs.

\*4 This connection is used for only GP2000 series units. When using other series units, use the GP430-IP10-0 cable.



\*5 ST Series units cannot use the GP430-IP10-0 cable.

\*6 When using this cable, be sure to set the Target Machine's communication settings to [RS-232C].

\*7 Can be used for GP2000 Series and GLC2000 Series only.

\*8 Can be used for ST Series only.

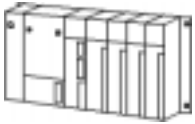
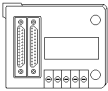
## ■ MELSEC-N Series (CPU Direct Connection)

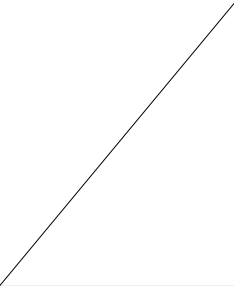
CPU <sup>*1</sup>	Adaptor	Cable Diagram	Cables	Target Machine
				
A1N,A2N,A3N,A3H, A1S,A2SH,A2CJS3, A1SH,A2CCPU24, A1SJ,A0J2H		RS-422 <Cable Diagram 11> <sup>*4</sup>	A-Series Programing Console I/F Cable (isolation type) GP430-IP10-O (5m) <sup>*5*6</sup> GP2000-CBLA/5M- 01(5m) <sup>*7</sup>	GP/GLC Series
			CA3-CBLA-01(5m) <sup>*8</sup>	ST400/ST403
			Diatrend Cable DAFXIH-CABV <sup>*6</sup>	ST401/ST403
A1N,A2N,A3N,A3H, A1S,A2SH,A1SH, A1SJ	2-Port Adaptor <sup>*2</sup> GP030-MD11-O	RS-422 (Refer to Mitsubishi's A Series PLC Manual "2 Port Adapter" for cable diagram information)	A-Series Programing Console I/F Cable (isolation type) GP430-IP10-O (5m) <sup>*5*6</sup>	GP/GLC Series
A1S,A2N,A3H,A3N, A1SJ,A2SH,A1SH, A2CJ-S3,A0J2H	2 Port Adaptor II <sup>*3</sup> GP070-MD11	RS-422 (Refer to Mitsubishi's A Series PLC Manual "2 Port AdapterII" for cable diagram information)	GP070-MDCB11(5m) cable or user-created RS-422Cable	GP/GLC Series
			Refer to "Connecting a Device/PLC to the ST unit." page 1-6 "2-Port Adaptor II"	ST400/ST403
	Mitsubishi's I/F unit FX-2PIF Refer to Mitsubishi's manual	RS-422 <Cable Diagram 11> <sup>*4</sup>	A-Series Programing Console I/F Cable (isolation type) GP430-IP10-O (5m) <sup>*5*6</sup> GP2000-CBLA/5M- 01(5m) <sup>*7</sup>	GP/GLC Series
			CA3-CBLA-01(5m) <sup>*8</sup>	ST400/ST403
			Diatrend Cable DAFXIH-CABV <sup>*6</sup>	ST401/ST403

*\*1 Connect to the Programming Console I/F port.*

*\*2 When a Read/Write command is sent from ladder software while data is being transmitted between the PLC and the GP, there is a possibility the data transmission will not be completed normally.*



**• If you connect a CPU not listed here via the Direct CPU connection, you may damage the PLC.**

**• If the PLC has two ports, both of them cannot be connected to a GP at the same time.**

*\*3 When using 2 Port Adapter II, refer to its manual for the connectable PLCs.*

*\*4 This connection is used for GP2000/GLC2000 and ST Series units. When using other series units, use the GP430-IP10-0 cable.*





*\*5 ST Series units cannot use the GP430-IP10-0 cable.*

*\*6 When using this cable, be sure to set the Target Machine's communication settings to [RS-232C].*

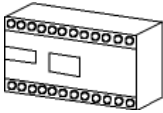

*\*7 Can be used for GP2000 Series and GLC2000 Series only.*

*\*8 Can be used for ST Series only.*

■ MELSEC-F<sub>2</sub> Series (using Link I/F)

CPU	Adapter	Cable Diagram	Cables	Target Machine
	 Interface Unit			
F <sub>2</sub> -20M, F <sub>2</sub> -40M, F <sub>2</sub> -60M	F <sub>2</sub> -232GF	RS-232C (Cable Diagram 1)	Digital's GP410-IS00-O(5m)cable Mitsubishi's F <sub>2</sub> -232CAB(3m)cable CA3-CBL232/5M-01 (5m)	GP/GLC Series  ST401/ST403

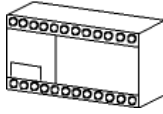
■ MELSEC-FX Series (A1FX) (using CPU Direct Connection)

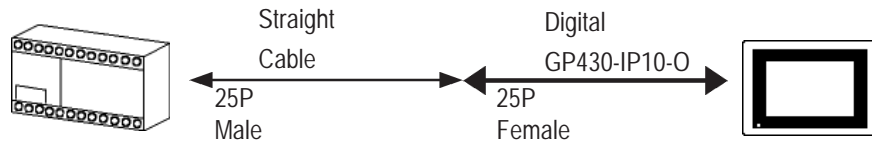

CPU	Cable Diagram	Cables	Target Machine
			
A1FX <sup>*1</sup>		GP410-IS00-O(5m) cable Mitsubishi's F <sub>2</sub> -232CAB(3m) cable <sup>*2</sup>	GP/GLC Series

\*1 When using an A1FX, choose the MELSEC-AnN (CPU) series as the GP-PRO/PBIII project file's PLC type (refer to the MELSEC-N series manuals for the range of devices available). You will also need a 25 Pin straight cable to adjust the connector's height to align it with that of the PLC's CPU cover.





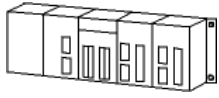
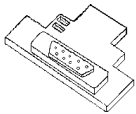

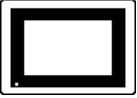
\*2 For ST series units, the GP430-IP10-0 cable cannot be used.

## ■ MELSEC-FX Series (Mitsubishi's MELSEC-FX2 (LINK) Protocol)

CPU	Adapter	Cable Diagram	Cables	Target Machine
	 (Expansion board)			
FX <sub>2N</sub> <sup>*1</sup>	FX <sub>2N</sub> -232-BD	RS-232C <Cable Diagram 6>		GP/GLC Series ST401/ST403
	FX <sub>2N</sub> -485-BD, FX <sub>0N</sub> -485ADP+ FX <sub>2N</sub> -CNV-BD	RS-422 <Cable Diagram 7>	GP230-IS11-O(5m)	GP/GLC Series
			CA3-CBL422/5M-01(5m)	ST400/ST403
FX <sub>2NC</sub> ,FX <sub>1NC</sub>	FX <sub>0N</sub> -232ADP	RS-232C <Cable Diagram 8>		GP/GLC Series ST401/ST403
	FX <sub>0N</sub> -485ADP	RS-422 <Cable Diagram 7>	GP230-IS11-O(5m)	GP/GLC Series
			CA3-CBL422/5M-01(5m)	ST400/ST403
FX <sub>1N</sub>	FX <sub>1N</sub> -232-BD	RS-232C <Cable Diagram 6>		GP/GLC Series ST401/ST403
	FX <sub>1N</sub> -485-BD, FX <sub>0N</sub> -485ADP+ FX <sub>1N</sub> -CNV-BD	RS-422 <Cable Diagram 7>	GP230-IS11-O(5m)	GP/GLC Series
			CA3-CBL422/5M-01(5m)	ST400/ST403
FX <sub>3UC</sub> , FX <sub>3U</sub>	FX <sub>3U</sub> -232-BD, FX <sub>3U</sub> -232ADP	RS-232C <Cable Diagram 6>		GP/GLC Series ST401/ST403
	FX <sub>3U</sub> -485-BD, FX <sub>3U</sub> -485ADP	RS-422C <Cable Diagram 7>	GP230-IS11-O(5m)	GP/GLC Series
			CA3-CBL422/5M-01(5m)	ST400/ST403

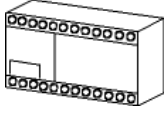
*\*1 The PLC's system version should be at least 1.06 or later. Check the PLC's version by reading out the data from the register (D8001). For detailed information refer to the Mitsubishi's FX 2N Series Micro Sequencer manuals.*

■ MELSEC-FX Series (Mitsubishi's MELSEC-FX(CPU) Protocol)

CPU	Adapter	Cable Diagram	Cables	Target Machine
				
FX <sub>1</sub> , *2 FX <sub>2</sub> , *2 FX <sub>2C</sub> , *2 FX <sub>0</sub> , *3 FX <sub>0S</sub> , *3 FX <sub>0N</sub> , *3 FX <sub>1S</sub> , *3 FX <sub>1N</sub> , *3 FX <sub>2N</sub> , *3 FX <sub>1NC</sub> , *3 FX <sub>2NC</sub> , *3 FX <sub>3UC</sub> , *3 FX <sub>3U</sub> *3			FX Series exclusive Programming Console I/F Cable (isolation type) GP430-IP11-O (5m) *8	GP/GLC Series
FX <sub>1</sub> , FX <sub>2</sub> , FX <sub>2C</sub> , FX <sub>0</sub> , FX <sub>0S</sub> , FX <sub>0N</sub> , FX <sub>1S</sub> , FX <sub>1N</sub> , FX <sub>2N</sub> , FX <sub>1NC</sub> , FX <sub>2NC</sub> , FX <sub>3UC</sub> , FX <sub>3U</sub>	Mitsubishi's I/F unit FX-232AW *1*4	RS-232C (Cable Diagram 1)	GP410-IS00-0(5m) Mitsubishi Corporation's F2-232CAB (3m) CA3-CBL232/5M-01 (5m)	GP/GLC Series ST401/ST403
FX <sub>2</sub> , *5 FX <sub>0S</sub> , *6 FX <sub>0N</sub> , *6 FX <sub>1S</sub> , *6 FX <sub>1N</sub> , *6 FX <sub>2N</sub> , *6 FX <sub>1NC</sub> , *6 FX <sub>2NC</sub> , *6 FX <sub>3UC</sub> , *6 FX <sub>3U</sub> *6	2 Port Adapter II GP070-MD11 *7	RS-422 (Refer to Mitsubishi's A Series PLC Manual "2 Port AdapterII" for cable diagram information) Refer to "Connecting a Device/PLC to the ST unit" page 1-6 "2-Port Adaptor II"	GP070-MDCB11 (5m) or User-Prepared cable (RS-422)	GP/GLC Series ST400/ST403

\*1 Although MELSEC-FX Series and the GP uses a CPU direct connection, to change an RS-422 signal to RS-232C's, the FX-232AW interface unit is necessary.

When connecting to FX<sub>1</sub>, FX<sub>2</sub>, and FX<sub>2C</sub>, it is necessary to connect the Interface Unit with the PLC using Mitsubishi's FX-422CAB.

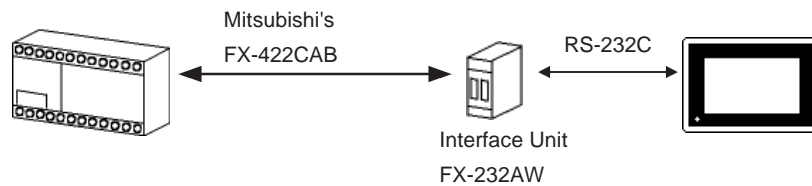

\*2 When using Digital's GP430-IP11-0 for connecting an FX<sub>1</sub>, FX<sub>2</sub>, or FX<sub>2C</sub>, use the Cable Diagram 2 shown below.

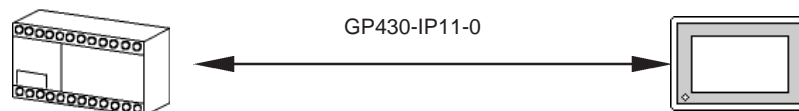

\*3 When using Digital's GP430-IP11-0 for connecting FX<sub>0</sub>, FX<sub>0S</sub>, FX<sub>0N</sub>, FX<sub>1S</sub>, FX<sub>1N</sub>, FX<sub>2N</sub>, FX<sub>1NC</sub>, FX<sub>2NC</sub>, FX<sub>3UC</sub> or FX<sub>3U</sub> be sure to use Mitsubishi's FX-20P-CADP cable.

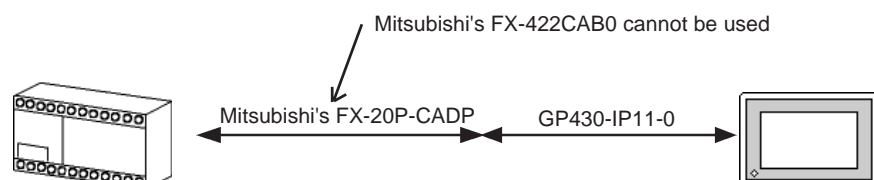



\*4 When connecting to  $FX_0$ ,  $FX_{0S}$ ,  $FX_{0N}$ ,  $FX_{1S}$ ,  $FX_{1N}$ ,  $FX_{2N}$ ,  $FX_{1NC}$ ,  $FX_{2NC}$ ,  $FX_{3UC}$  or  $FX_{3U}$  it is necessary to connect the Interface Unit with the PLC using Mitsubishi's FX-422CAB0 (see Diagram 4).

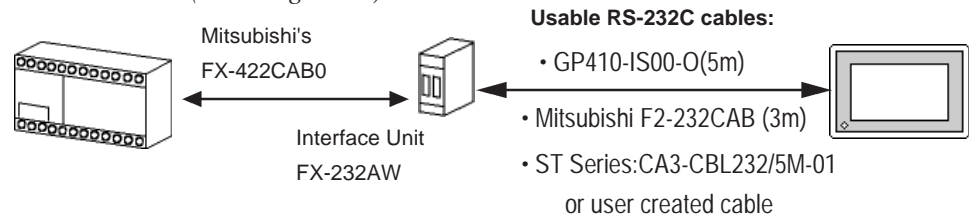

\*5 When using Digital's 2 Port Adapter II, it is necessary to connect the unit to the GP as shown below.

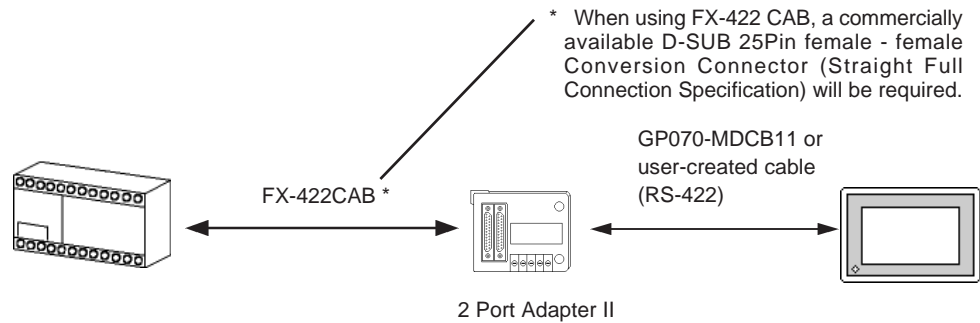

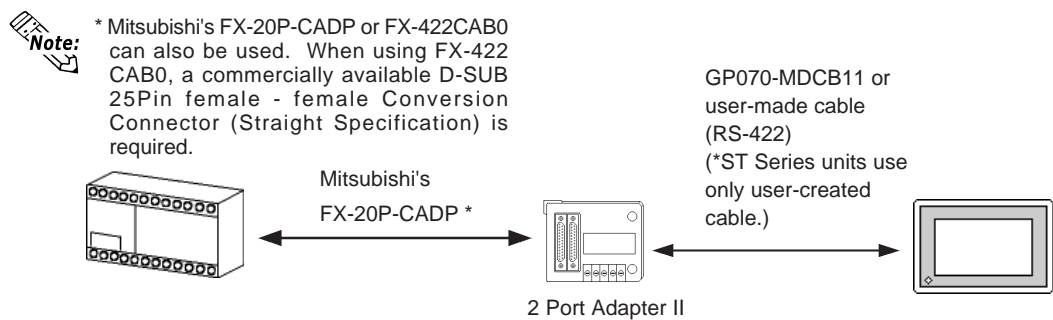

\*6 When using Digital's 2 Port Adapter II, it is necessary to connect the units to the GP as shown below.



\*7 When using 2 Port Adapter II, refer to its manual for connectable PLCs.

\*8 For the ST series units, the GP430-IP11-0 cable cannot be used.

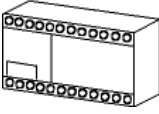
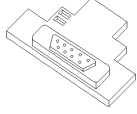
■ MELSEC-FX Series (using Expansion Board with Mitsubishi's MELSEC-FX (CPU) Protocol)

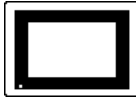
CPU	Expansion board	Cable Diagram	Cables	Target Machine
				
FX <sub>1S</sub> , FX <sub>1N</sub>	FX <sub>1N</sub> -232-BD	RS-232C <sup>*1</sup> <Cable Diagram 1>	GP410-IS00-O (5m)	GP/GLC Series
			Mitsubishi Electric F2-232CAB-1 (3m)	
		RS-232C <Cable Diagram 6>	CA3-CBL232/5M-01(5m)	ST401/ST403
			Mitsubishi Electric FX-232CAB-1 (3m)	
FX <sub>2N</sub>	FX <sub>2N</sub> -422-BD <sup>*2</sup>	/		GP/GLC Series
		/		ST401/ST403
FX <sub>2N</sub>	FX <sub>2N</sub> -232-BD	RS-232C <sup>*1</sup> <Cable Diagram 1>	GP410-IS00-O (5m)	GP/GLC Series
			Mitsubishi Electric F2-232CAB-1 (3m)	
		RS-232C <Cable Diagram 6>	CA3-CBL232/5M-01(5m)	ST401/ST403
			Mitsubishi Electric FX-232CAB-1 (3m)	
FX <sub>3UC</sub> , FX <sub>3U</sub>	FX <sub>3U</sub> -422-BD <sup>*2</sup>	/		GP/GLC Series
		/		ST401/ST403
FX <sub>3UC</sub> , FX <sub>3U</sub>	FX <sub>3U</sub> -232-BD, FX <sub>3U</sub> -232ADP	RS-232C <sup>*1</sup> <Cable Diagram 1>	GP410-IS00-O (5m)	GP/GLC Series
			Mitsubishi Electric F2-232CAB-1 (3m)	
		RS-232C <Cable Diagram 6>	CA3-CBL232/5M-01(5m)	ST401/ST403
			Mitsubishi Electric FX-232CAB-1 (3m)	
FX <sub>3UC</sub> , FX <sub>3U</sub>	FX <sub>3U</sub> -422-BD + Mitsubishi Electric RS-232C/RS-422 Conversion Unit FX-232AW <sup>*3</sup>	RS-232C <Cable Diagram 1>	GP410-IS00-O (5m)	GP/GLC Series
			Mitsubishi Electric F2-232CAB-1 (3m)	
		RS-422 (Refer to Mitsubishi's A Series PLC Manual "2 Port AdapterII" for cable diagram information)	CA3-CBL232/5M-01(5m)	ST401/ST403
			GP070-MDCB11 (5m) or User-Prepared cable (RS-422)	
FX <sub>3UC</sub> , FX <sub>3U</sub>	FX <sub>3U</sub> -422-BD + 2-Port Adaptor II GP070-MD11 <sup>*4</sup>	Refer to "Connecting a Device/PLC to the ST unit" page 1-6 "2-Port Adaptor II"	_____	ST400/ST403

\*1 When using a GP410-IS00-O, a 9 pin <--> 25 pin conversion adaptor (straight type) is required. The F2-232CAB-1 does not require conversion adaptor and can be connected directly to PLC.

With a GP/GLC Series Unit:

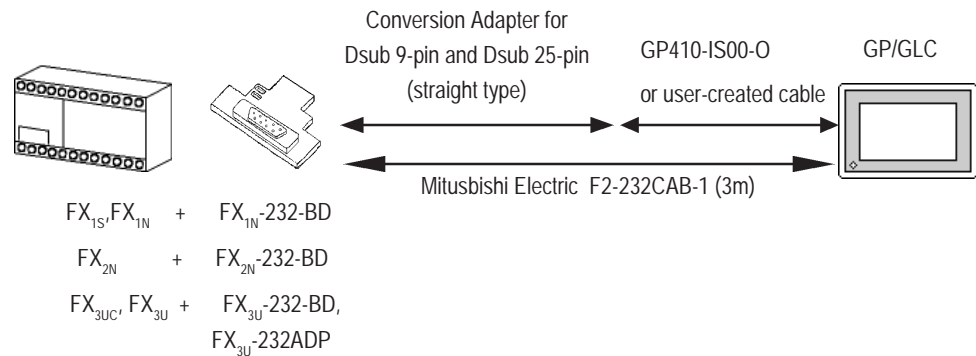

When using a CA3-CBL232/5M-01, a 9 pin <--> 25 pin conversion adaptor (straight type) is required. The FX-232CAB-1 does not require conversion adaptor and can be connected directly to PLC.

With an ST Series Unit:

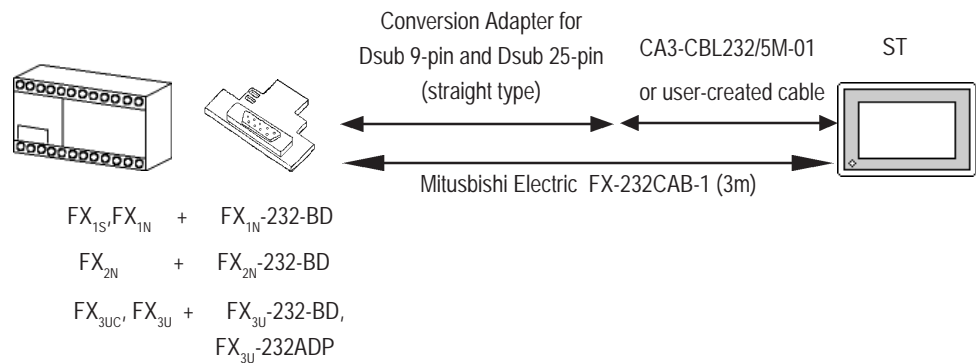

\*2 A round Dsub 8-pin to 25-pin conversion cable is required. (Mitsubishi Electronic FX-20P-CADP)

With a GP/GLC Series Unit:

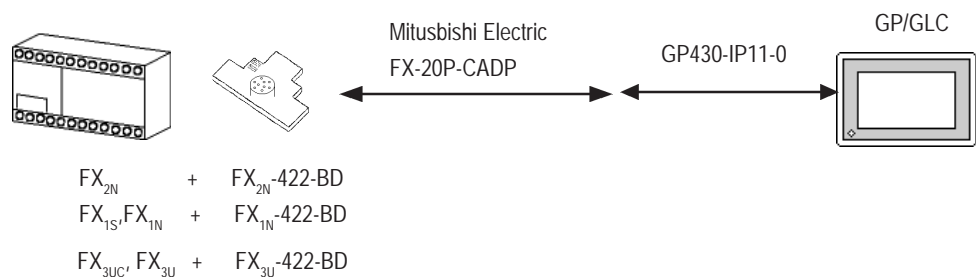

\*3 When connecting to an FX3UC, use a Mitsubishi Electric FX-422CAB0 cable to connect the FX3U-422-BD adaptor and the Interface Unit.

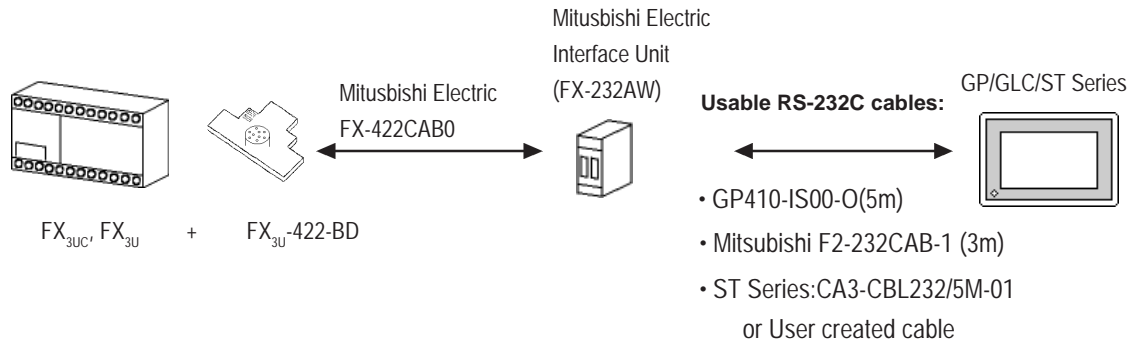

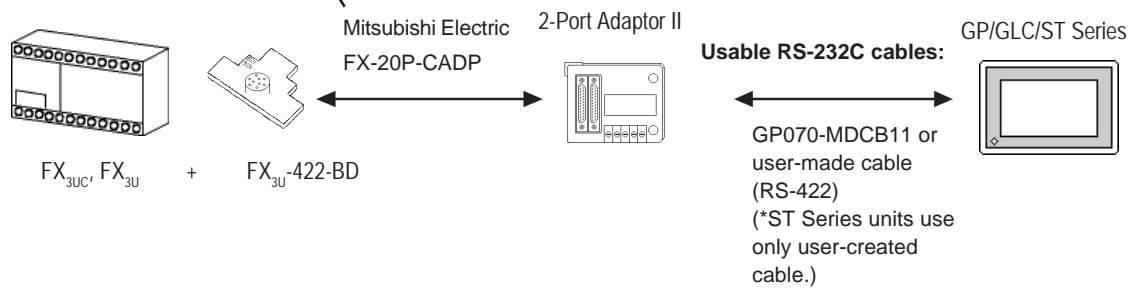

\*4 When using Digital Electric Corporation's 2 Port Adaptor II, it is necessary to connect the units to the GP as shown below.

\* Mitsubishi's FX-20P-CADP or FX-422CAB0 can also be used. When using FX-422 CAB0, a commercially available D-SUB 25Pin female - female Conversion Connector (Straight Specification) is required.



\*5 For ST Series units, the GP430-IP11-0 cable cannot be used.

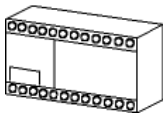

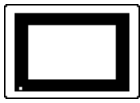
■ MELSEC-FX Series (using Mitsubishi's MELSEC-FX (CPU2) Protocol)

CPU	Cable Diagram	Cable	GP/GLC
			
FX0S, FX0N, FX1S, FX1N, FX1NC, FX2N, FX2NC, FX3UC, FX3U	RS-422 <Cable Diagram 12> <sup>*2</sup>	GP2000-CBLFX/5M-01 (5M)	GP/GLC Series <sup>*1</sup>
		GP2000-CBLFX/1M-01 (1M)	
		CA3-CBLFX/5M-01 (5m)	ST400/ST403
		CA3-CBLFX/1M-01 (1m)	

\*1 In the GP70 Series, only GP377 Series units can use this cable.

\*2 When connecting to a Device/PLC, be sure to use one of the option cables shown here.

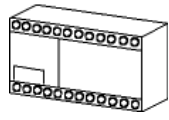
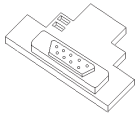
■ MELSEC-FX Series (using Expansion Board with Mitsubishi's MELSEC-FX (CPU2) Protocol)

CPU	Expansion board	Cable Diagram	Cables	Target Machine
				
FX3UC, FX3U	FX3U-232-BD, FX3U-232ADP	RS-232C <sup>*1</sup> <Cable Diagram 1>	GP410-IS00-O (5m)	GP/GLC Series
			Mitsubishi Electric F2-232CAB-1 (3m)	
			CA3-CBL232/5M-01(5m)	ST401/ST403
			Mitsubishi Electric FX-232CAB-1 (3m)	
		RS-232C <Cable Diagram 6>	—————	GP/GLC Series ST401/ST403
	FX3U-422-BD <sup>*2</sup>		GP430-IP11-O (5m) <sup>*5</sup>	GP/GLC Series
	FX3U-422-BD + Mitsubishi Electric RS-232C/RS-422 Conversion Unit FX-232AW <sup>*3</sup>	RS-232C <Cable Diagram 1>	GP410-IS00-O (5m)	GP/GLC Series
			Mitsubishi Electric F2-232CAB-1 (3m)	
	CA3-CBL232/5M-01(5m)	ST401/ST403		
FX3U-422-BD + 2-Port Adaptor II GP070-MD11 <sup>*4</sup>	RS-422 (Refer to Mitsubishi's A Series PLC Manual "2 Port AdapterII" for cable diagram information)	GP070-MDCB11 (5m) or User-Prepared cable (RS-422)	GP/GLC Series	
		Refer to "Connecting a Device/PLC to the ST unit" page 1-6 "2-Port Adaptor II"	————— ST400/ST403	

\*1 When using a GP410-IS00-O, a 9 pin <--> 25 pin conversion adaptor (straight type) is required. The F2-232CAB-1 does not require conversion adaptor and can be connected directly to PLC.

With a GP/GLC Series Unit:

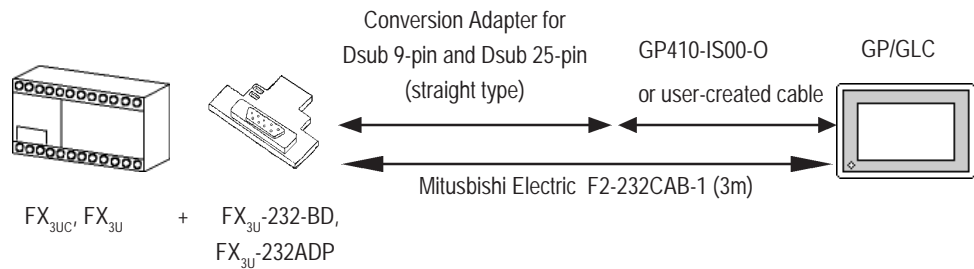

When using a CA3-CBL232/5M-01, a 9 pin <--> 25 pin conversion adaptor (straight type) is required. The FX-232CAB-1 does not require conversion adaptor and can be connected directly to PLC.

With an ST Series Unit:

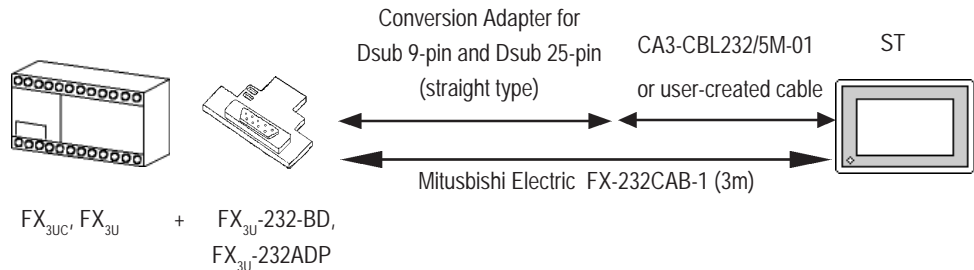

\*2 A round Dsub 8-pin to 25-pin conversion cable is required. (Mitsubishi Electric FX-20P-CADP)

With a GP/GLC Series Unit:

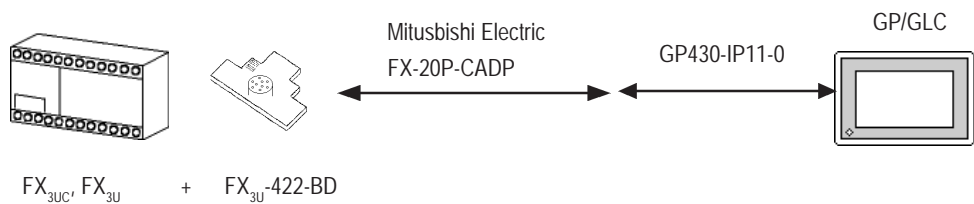

\*3 When connecting to an FX3UC, use a Mitsubishi Electric FX-422CAB0 cable to connect the FX3U-422-BD adaptor and the Interface Unit.

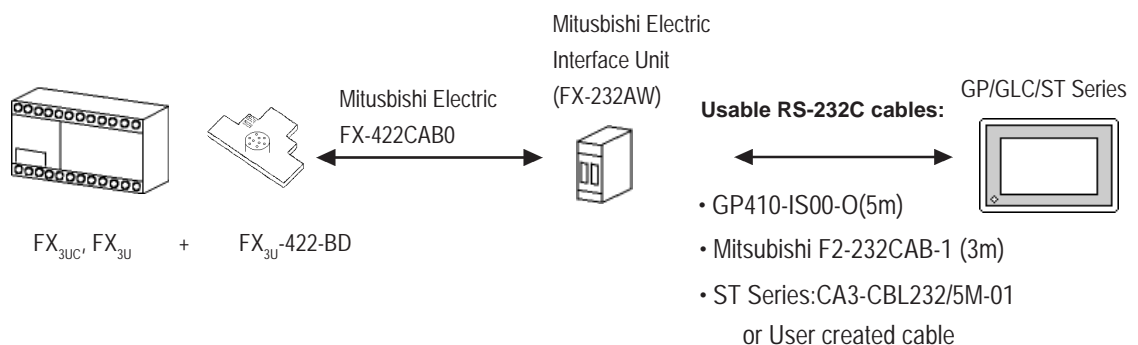

\*4 When using Digital Electric Corporation's 2 Port Adapter II, it is necessary to connect the units to the GP as shown below.

\* Mitsubishi's FX-20P-CADP or FX-422CAB0 can also be used. When using FX-422 CAB0, a commercially available D-SUB 25Pin female - female Conversion Connector (Straight Specification) is required.

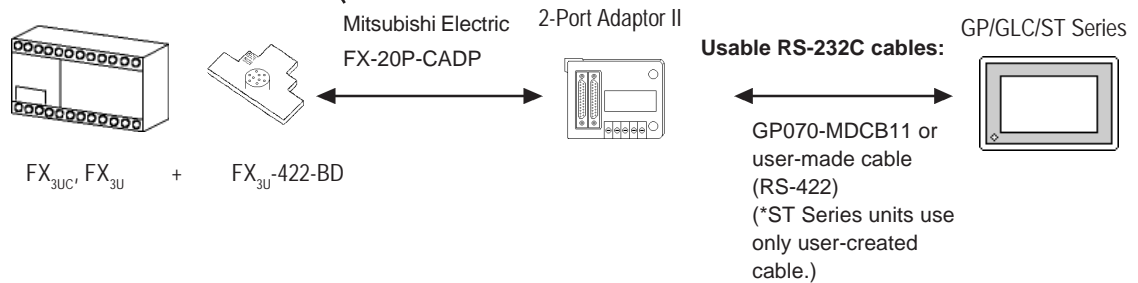

\*5 For ST Series units, the GP430-IP11-0 cable cannot be used.

**MELSEC-FX Series (using Mitsubishi's MELSEC-FX 1:N Communication Protocol)**

CPU	Adapter	Cable Diagram	Cables	Target Machine
	<b>Expansion Board or Adaptor</b> 			
$FX_{1N}$	$FX_{1N}-485-BD,$ $FX_{0N}-485ADP+FX_{1N}-CNV-BD$	RS-422 (4-wire) (Cable Diagram 13)	—	GP/GLC Series <sup>*2</sup>
$FX_{1NC}$	$FX_{0N}-485ADP$			
$FX_{2N}$ <sup>*1</sup>	$FX_{2N}-485-BD,$ $FX_{0N}-485ADP+FX_{2N}-CNV-BD$	RS-422 (2-wire) (Cable Diagram 14)	—	ST400/ST403
$FX_{2NC}$	$FX_{0N}-485ADP$			
$FX_{3UC}, FX_{3U}$	$FX_{3U}-485-BD, FX_{3U}-485ADP$			





\*1 The PLC's system version should be at least 1.06 or later. Check the PLC's version by reading out the data from the register (D8001). For detailed information refer to the Mitsubishi's FX 2N Series Micro Sequencer manuals.

\*2 In the GP70 Series, only GP377 Series units can use this cable.



**With a 1:n connection, a maximum of 8 PLC units can be connected.**

## ■ MELSEC-QnA Series (using Link I/F)



CPU	Link I/F	Cable Diagram	Cables	Target Machine
	Serial Communication Unit / Computer Link Unit 			
Q2A,Q2A-S1,Q4A	AJ71QC24 (Serial Communication Unit) <sup>*1</sup>	RS-232C <Cable Diagram 1>	GP410-IS00-O (5m)	GP/GLC Series
			CA3-CBL232/5M-01 (5m)	ST401/ST403
	AJ71UC24 (Computer Link Unit)	RS-422 <Cable Diagram 2>	GP230-IS11-0(5m)	GP/GLC Series
			CA3-CBL422/5M-01 (5m)	ST400/ST403
	AJ71QC24N-R4	RS-422 (for CN-2) <Cable Diagram 2>	GP230-IS11-0(5m)	GP/GLC Series
			CA3-CBL422/5M-01 (5m)	ST400/ST403
	RS-422 (for CN-1) <Cable Diagram 5>	—————	GP/GLC Series	
		—————	ST400/ST403	
Q2AS,Q2ASH	A1SJ71QC24 (Serial Communication Unit) <sup>*2</sup>	RS-232C <Cable Diagram 3>	GP000-IS02-MS(3m)	GP/GLC Series
			—————	ST401/ST403
	A1SJ71UC24 (Computer Link Unit)	RS-422 <Cable Diagram 2>	GP230-IS11-0(5m)	GP/GLC Series
			CA3-CBL422/5M-01 (5m)	ST400/ST403
Q2AS-S1	A1SJ71UC24-R2	RS-232C <Cable Diagram 3>	GP000-IS02-MS(3m)	GP/GLC Series
			—————	ST401/ST403
	A1SJ71UC24-R4	RS-422 <Cable Diagram 2>	GP230-IS11-0(5m)	GP/GLC Series
			CA3-CBL422/5M-01 (5m)	ST400/ST403
	A1SJ71QC24N	RS-232C <Cable Diagram 3>	GP000-IS02-MS(3m)	GP/GLC Series
			—————	ST401/ST403
		RS-422 <Cable Diagram 2>	GP230-IS11-0(5m)	GP/GLC Series
			CA3-CBL422/5M-01 (5m)	ST400/ST403
A1SJ71QC24N1	RS-232C <Cable Diagram 15>	GP000-IS02-MS(3m)	GP/GLC Series	
	RS-422 <Cable Diagram 16>	GP230-IS11-0(5m)	GP/GLC Series	
Q4AR	AJ71QC24N	RS-232C <Cable Diagram 1>	GP410-IS00-O (5m)	GP/GLC Series
			CA3-CBL232/5M-01 (5m)	ST401/ST403
		RS-422 <Cable Diagram 2>	GP230-IS11-0(5m)	GP/GLC Series
			CA3-CBL422/5M-01 (5m)	ST400/ST403

\*1 ROM : must be 7179B or higher.

\*2 ROM : must be 7179M or higher.

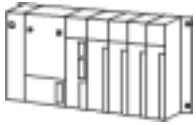
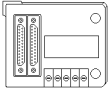

■ MELSEC-QnA Series (CPU Direct Connection)

CPU <sup>*1</sup>	Adaptor	Cable Diagram	Cables	Target Machine
				
Q4A, Q2A, Q2AS, Q2AS-S1, Q2A-S1, Q2ASH, Q4AR	/	RS-422 <Cable Diagram 11> <sup>*3</sup>	GP430-IP10-O (5m) <sup>*5</sup> GP2000-CBLA/5M-01(5m) <sup>*6</sup>	GP/GLC Series
			CA3-CBLA-01(5m) <sup>*7</sup>	ST400/ST403
		Diatrend Cable DAFXIH-CABV <sup>*5</sup>	ST401/ST403	
Q4A, Q2A, Q2AS, Q2AS-S1	2-Port Adaptor <sup>*1</sup> GP030-MD11-O <sup>*2</sup>	RS-422 (Refer to Mitsubishi's A Series PLC Manual "2 Port Adapter" for cable diagram information)	GP430-IP10-O (5m) <sup>*4,5</sup>	GP/GLC Series
Q4A, Q2A, Q2ASH, Q2AS-S1, Q2A-S1	2 Port Adaptor II <sup>*1</sup> GP070-MD11 <sup>*2</sup>	RS-422 (Refer to Mitsubishi's A Series PLC Manual "2 Port AdapterII" for cable diagram information)	GP070-MDCB11(5m) cable or user-created RS-422Cable	GP/GLC Series
		Refer to "Connecting a Device/PLC to the ST unit" page 1-6 "2-Port Adaptor II"	—————	ST400/ST403

\*1 When using 2 Port Adapter II, refer to its manual for the connectable PLCs.

\*2 When a Read/Write command is sent from ladder software while data is being transmitted between the PLC and the GP, there is a possibility the data transmission will not be completed normally. You may need to set the GP to the OFFLINE mode before you Read/Write in the program

\*3 This connection is used for the GP2000/GLC2000 and ST series units. When using other series unit, use the GP430-IP10-0.

\*4 For the ST series units, the GP430-IP11-0 units cannot be used.



**Digital's 2-port Adapter (GP030-MD11-0) will have this identification label.**





**Adapters that support the MELSEC-QnA unit have a circle around the "B" or later character.**

\*5 When using this cable, be sure to set the Target Machine's communication settings to [RS-232C].

\*6 Can be used for GP2000 Series and GLC2000 Series only.

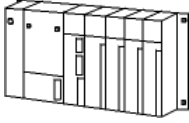
\*7 Can be used for ST Series only.



### ■ MELSEC-Q Series (using Link I/F)

CPU	Link I/F	Cable Diagram	Cables	Target Machine
	Serial Communication Unit / Computer Link Unit 			
Q02CPU-A, Q02HCPU-A, Q06HCPU-A	A1SJ71UC24-R2	RS-232C <Cable Diagram 3>	GP000-IS02-MS (3m) —————	GP/GLC Series ST401/ST403
	A1SJ71UC24-R4	RS-422 <Cable Diagram 2>	GP230-IS11-0(5m) CA3-CBL422/5M-01(5m)	GP/GLC Series ST400/ST403
Q02CPU, Q02HCPU, Q06HCPU, Q12HCPU, Q25HCPU, Q00CPU, Q01CPU, Q00JCPU	QJ71C24 QJ71C24N	RS-232C <Cable Diagram 3>	GP000-IS02-MS (3m) —————	GP/GLC Series ST401/ST403
		RS-422 <Cable Diagram 2>	GP230-IS11-0(5m) CA3-CBL422/5M-01(5m)	GP/GLC Series ST401/ST403
	QJ71C24N-R4	RS-422 <Cable Diagram 2>	GP230-IS11-0(5m) CA3-CBL422/5M-01(5m)	GP/GLC Series ST400/ST403
		RS-232C <Cable Diagram 3>	GP000-IS02-MS (3m) —————	GP/GLC Series ST401/ST403

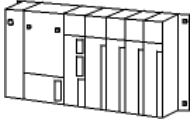

**Note:** When connecting a link I/F to a MELSEC-Q Series unit CPU, refer to the MELSEC-Q Series User Manual for a list of connectable (usable) devices.

## ■ MELSEC-Q Series (CPU Direct Connection)

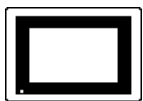
CPU	Cable Diagram	Cable	Target Machine
			
Q02CPU-A Q02HCPU-A Q06HCPU-A Q02CPU Q02HCPU Q06HCPU Q12HCPU Q25HCPU Q00CPU <sup>*4</sup> Q01CPU <sup>*4</sup> Q00JCPU <sup>*4</sup>	RS-232C <Cable Diagram 9>	Mitsubishi Electric QC30R2(3m) (Requires 9<->25 pin conversion adaptor)	GP/GLC Series
		Mitsubishi Electric QC30R2(3m) (Does not require adaptor)	ST401/ST403
	RS-232C <Cable Diagram 10>	GP2000-CBLO/5M- 01(5m) <sup>*2</sup> Diatrend Corporation DQCABR2-H(3m) <sup>*1</sup>	GP/GLC Series
		CA3-CBLO-01(5m) <sup>*3</sup> Diatrend Corporation DQCABR2-H(3m) <sup>*1</sup> (Requires 9<->25 pin conversion adaptor)	ST401/ST403

*\*1 When designating the length of a cable, be sure to use meters (\*m).*

*For the available range of cable lengths, please contact the Diatrend company.*

*\*2 Can be used for GP2000 Series and GLC2000 Series only.*

*\*3 Can be used for ST Series only.*

*\*4 When using the Mitsubishi MELSEC-QUTE(CPU) protocol, GP70 Series except GP377 Series can not be used.*

## 2.1.2 Cable Diagrams

The cable diagram illustrated below and the cable diagrams recommended by Mitsubishi Electric Corporation may differ. Using these cables for your PLC, however, will not cause any problems.



*Ground your PLC's FG terminal according to your country's applicable standard. For details, refer to the corresponding PLC manual.*

- **Connect the FG line of the Shield cable to either the GP or PLC, depending on your environment. When using a connector hood and grounding the FG line, be sure to use an electrical conductor. The following connection diagrams show examples for connecting a shielded cable to the PLC.**
- **For the RS-232C connection, use a cable length less than 15m.**
- **If a shielded cable is connected to the RS-422 port, it must be no longer than 600 m.**
- **If a communications cable is used, it must be connected to the SG (signal ground).**

Cable Diagram 1

### GP/GLC Series Units

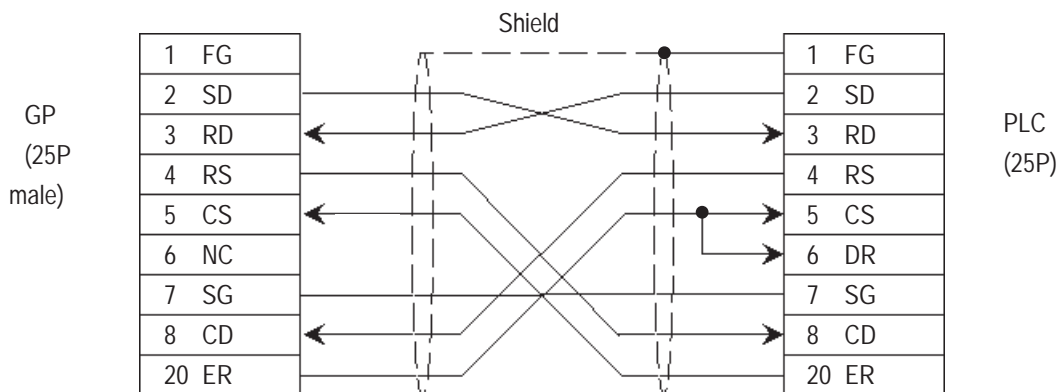

### ST401/ST403 Unit

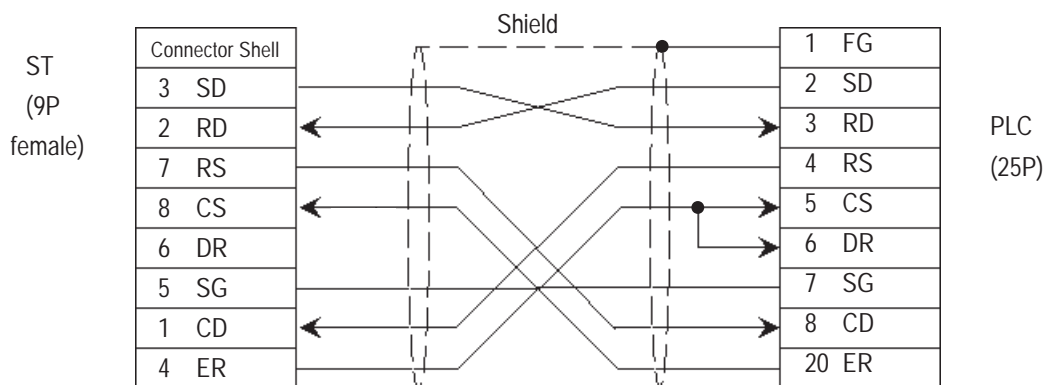

**Cable Diagram 2**



- Turn on the PLC's termination resistance switch.
- Depending on the type of PLC used, a termination resistance of  $330\Omega$  1/2W or  $330\Omega$  1/4W is needed between SDA and SDB, and also between RDA and RDB if no DIP switch is available. For details, refer to the corresponding PLC Manual.

**GP/GLC Series Units**

- When using Digital's RS-422 connector terminal adapter GP070-CN10-0

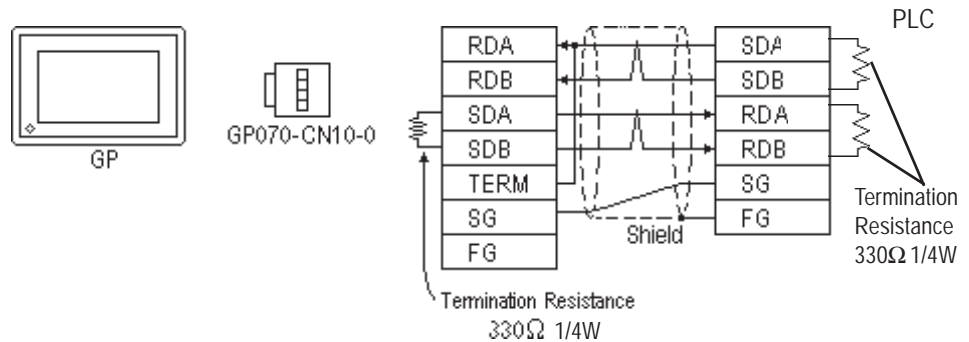

- When using Digital's RS-422 Cable, GP230-IS11-0

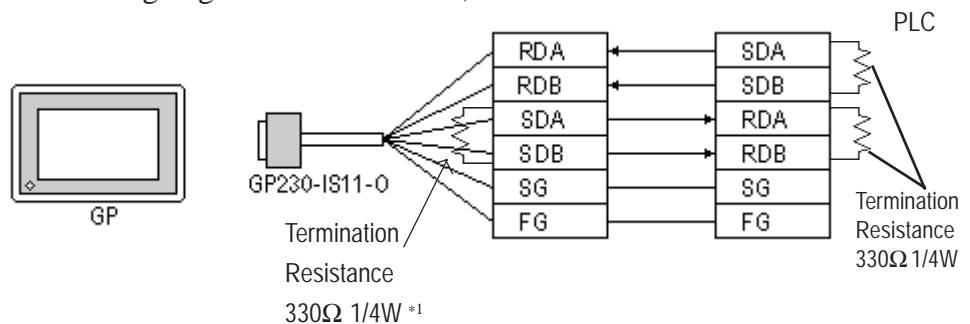

\*1 When extending the length of the cable, be sure to insert termination resistance between SDA and SDB.

- When making your own cable connections

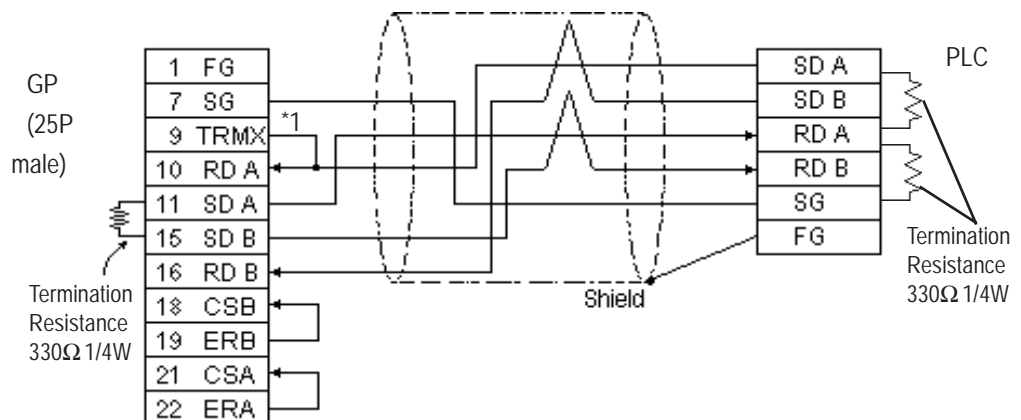

\*1 When connecting the #9 and #10 pins in the GP Serial I/F, a termination resistance of  $100\Omega$  is added between RDA and RDB.



- When making your own cable connections, we recommend using Mitsubishi's SPEV (SB)-MPC-0.2\*3P for the cable.

### ST400/ST403 Unit

- When using Digital's RS-422 cable CA3-CBL422/5M-01

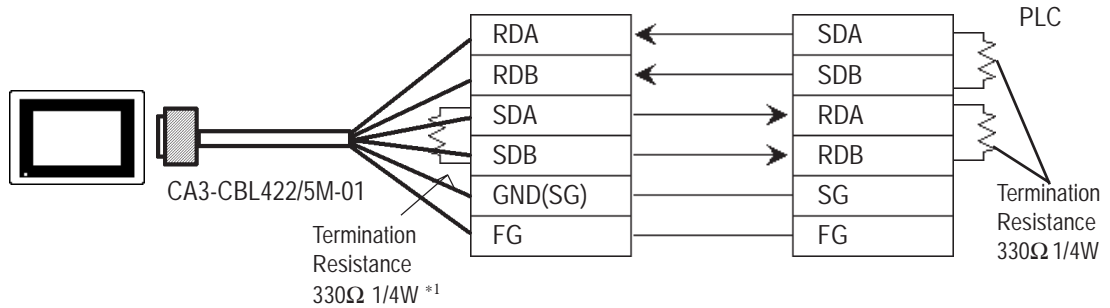

*\*1 When extending the length of the cable, be sure to insert termination resistance between SDA and SDB.*

- When making your own cable connections

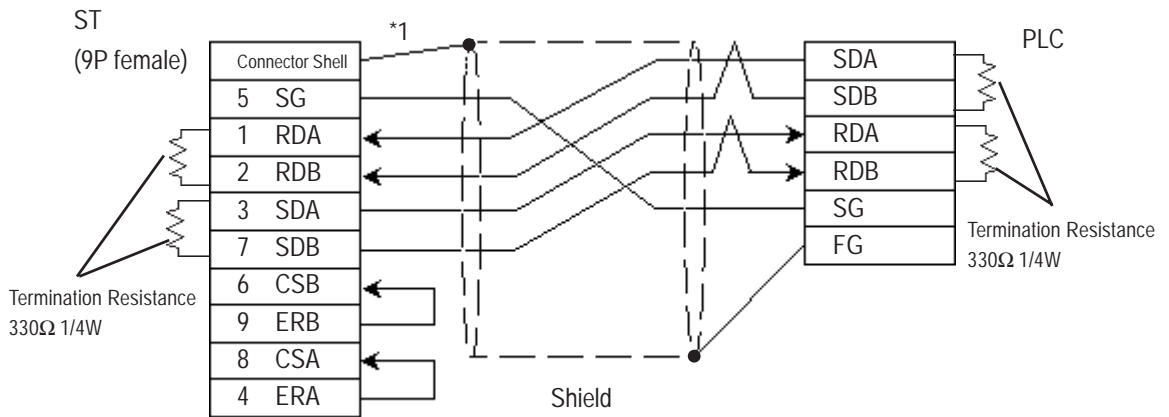

*\*1 Be sure to connect the shield to the Connector Shell. For information about FG connections, refer to page 1-2 "RS422 I/F (ST400/ST403)" section's Note, in the "Connecting a Device/PLC to the ST unit."*



- When making your own cable connections, we recommend using Mitsubishi's SPEV (SB)-MPC-0.2\*3P for the cable.

### Cable Diagram 3

#### GP/GLC Series Units

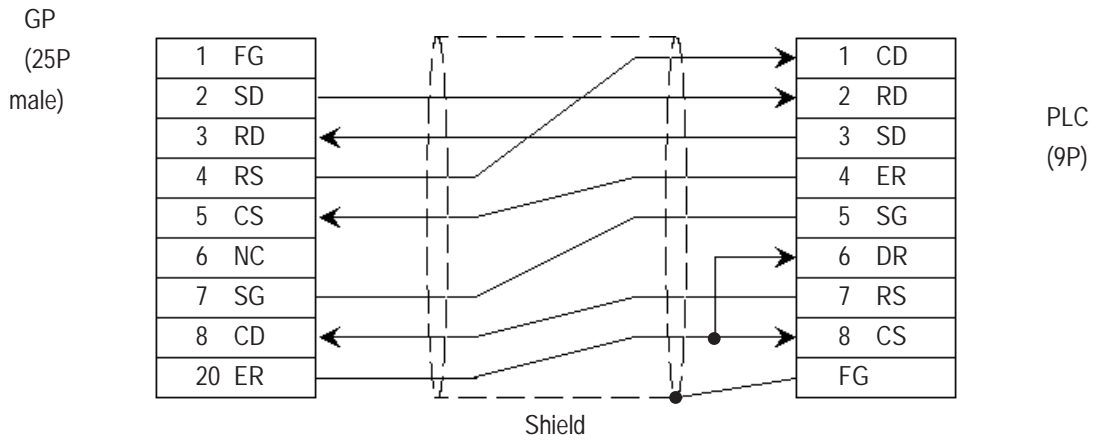

*Be sure to connect the shield line to the PLC unit's terminal block FG terminal.*

#### ST401/ST403 Unit

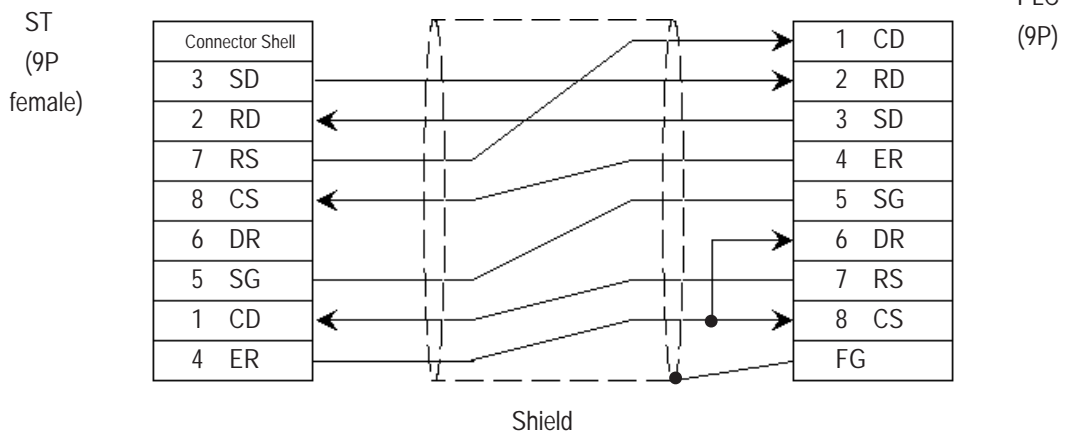

*Be sure to connect the shield line to the PLC unit's terminal block FG terminal.*

### Cable Diagram 4

#### GP/GLC Series Units

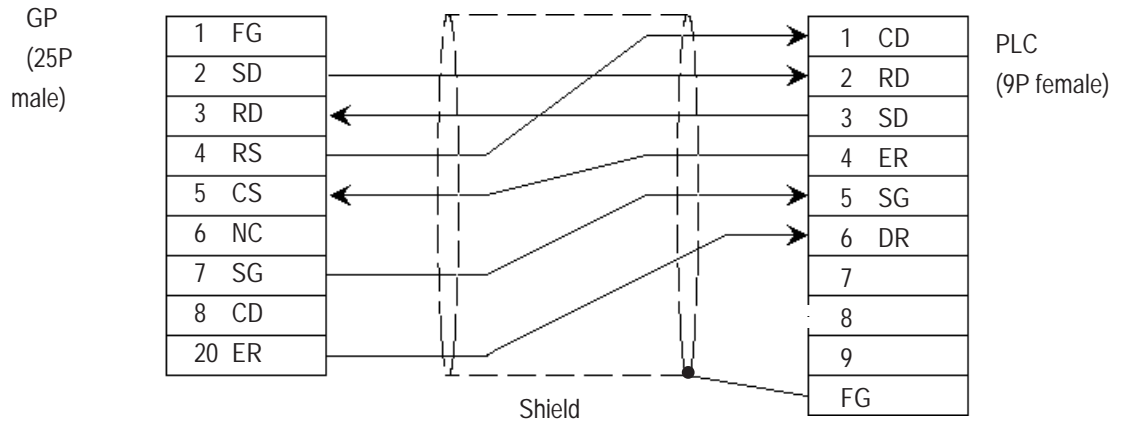

#### ST401/ST403 Unit

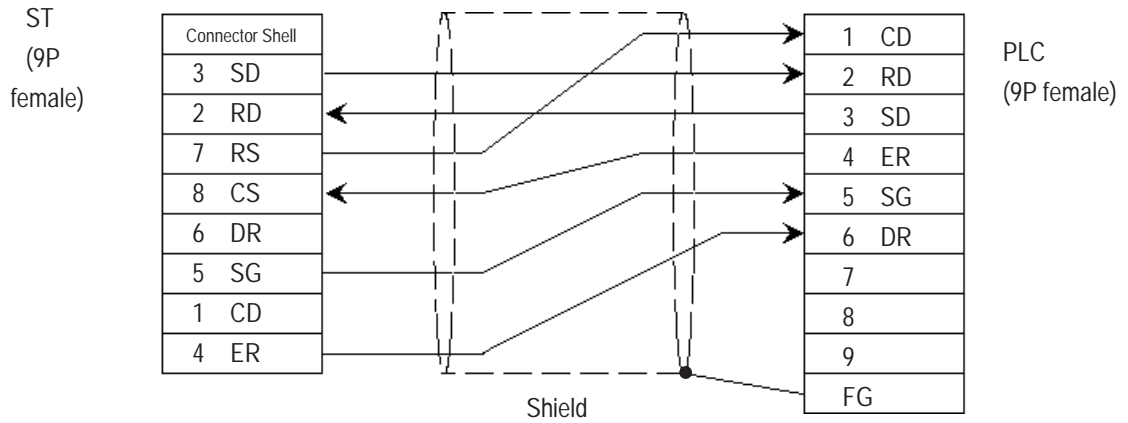



### Cable Diagram 5 GP/GLC Series Units

- When using Digital's RS-422 connector terminal adapter GP070-CN10-0

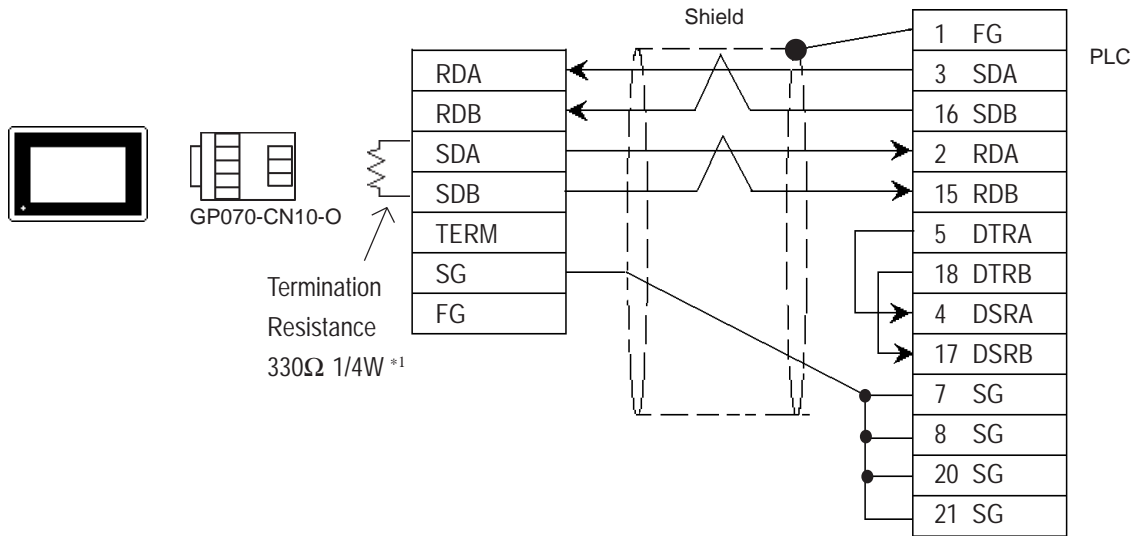

- When using Digital's RS-422 connector terminal adapter GP230-IS11-0

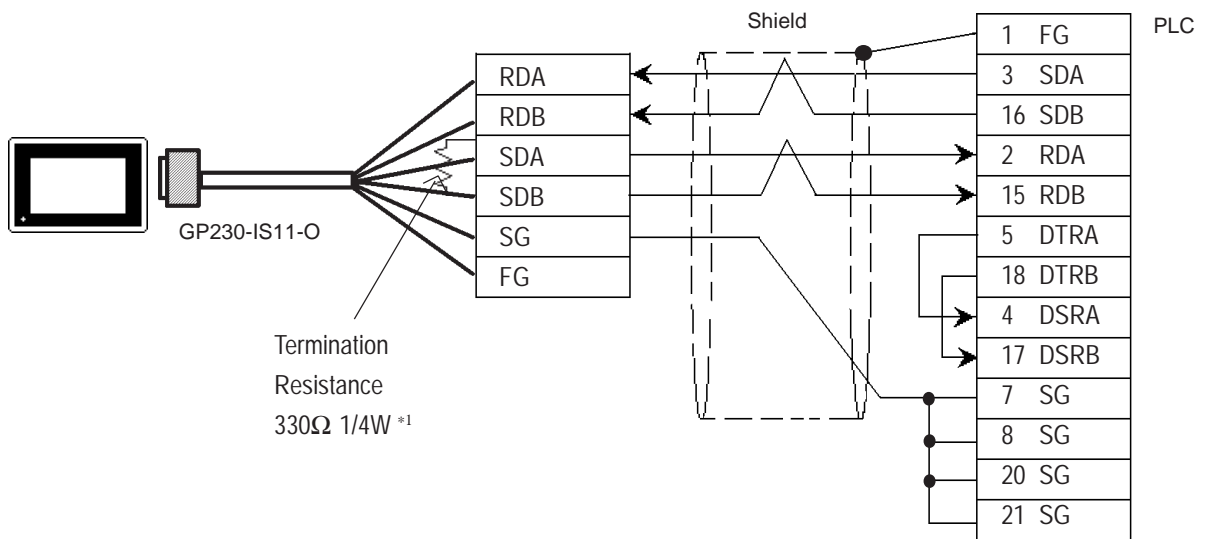

*\*1 When extending the length of the cable, be sure to insert termination resistance between SDA and SDB.*

- When making your own cable

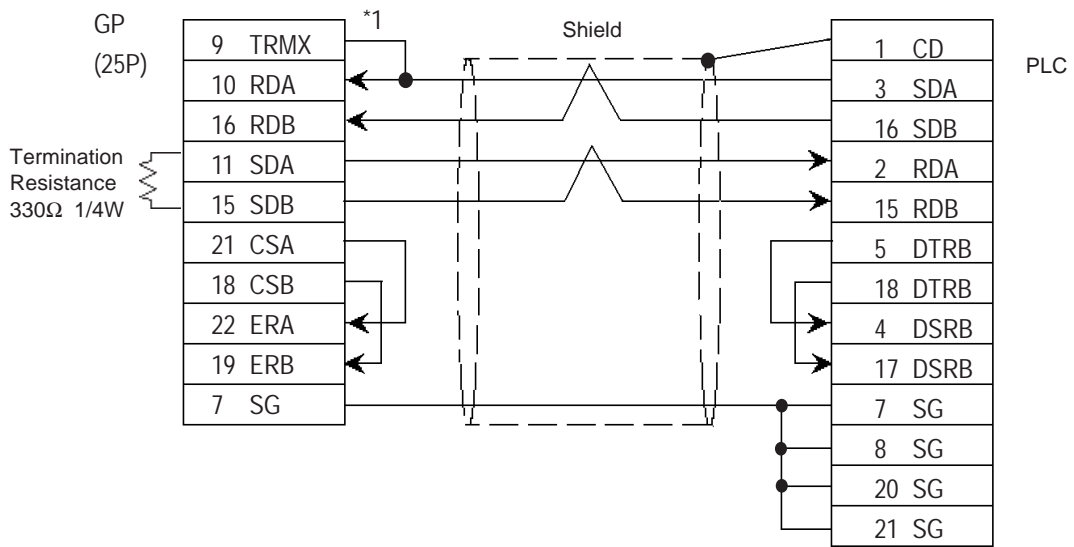

\*1 When connecting the #9 and #10 pins in the GP Serial I/F, a termination resistance of 100Ω is added between RDA and RDB.



- When making your own cable connections, we recommend using Mitsubishi's SPEV (SB)-MPC-0.2\*3P for the cable.

### ST400/ST403 Unit

- When using Digital's RS-422 cable CA3-CBL422/5M-01

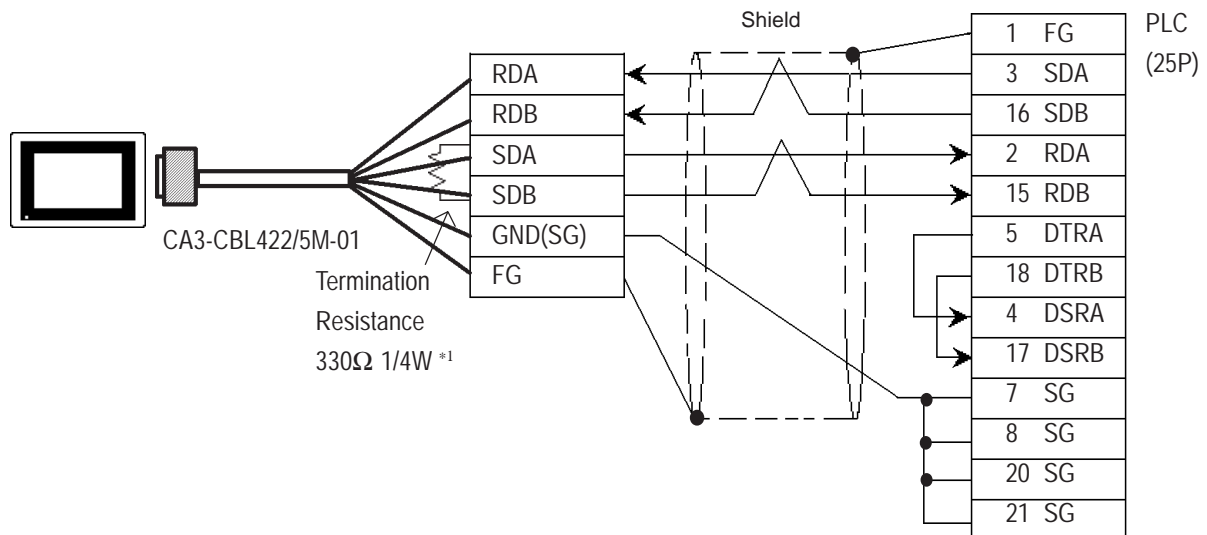

\*1 When extending the length of the cable, be sure to insert termination resistance between SDA and SDB.



- Be sure to connect the FG line to the FG terminal. For information about FG connections, refer to page 1-5 note \*1, in the "Connecting a Device/PLC to the ST unit."

- When making your own cable connections

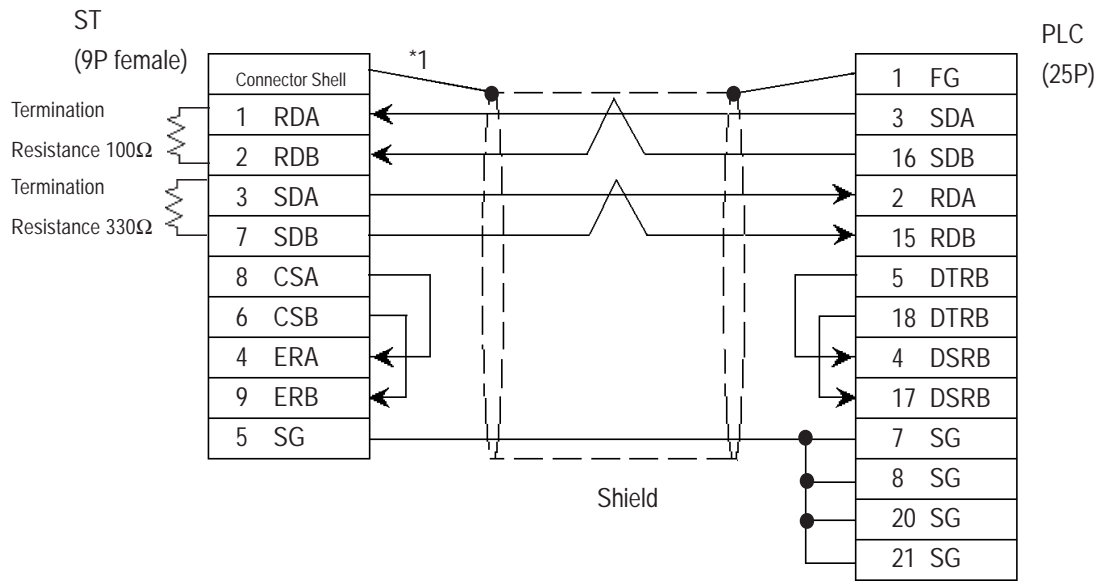

\*1 Be sure to connect the shield to the Connector Shell. For information about FG connections, refer to page 1-2 "RS422 I/F (ST400/ST403)" section's Note, in the "Connecting a Device/PLC to the ST unit."

### Cable Diagram 6

#### GP/GLC Series Units

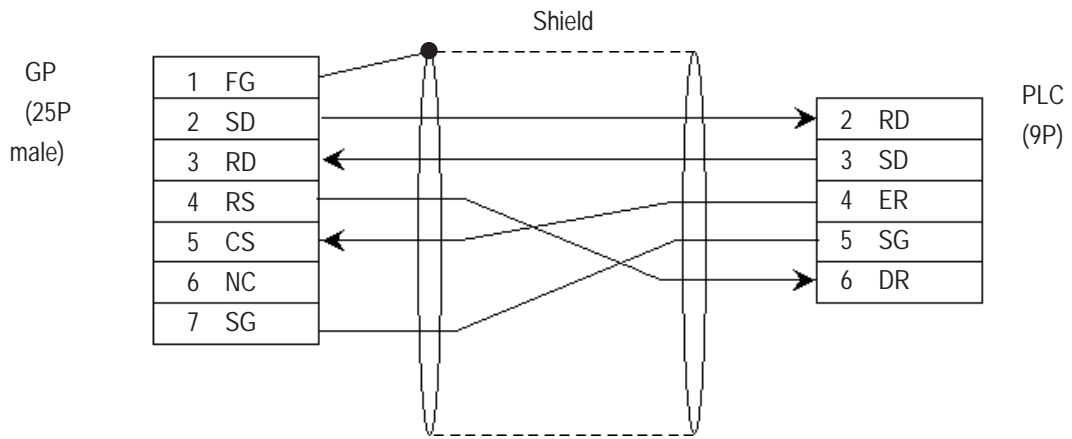

#### ST401/ST403 Unit

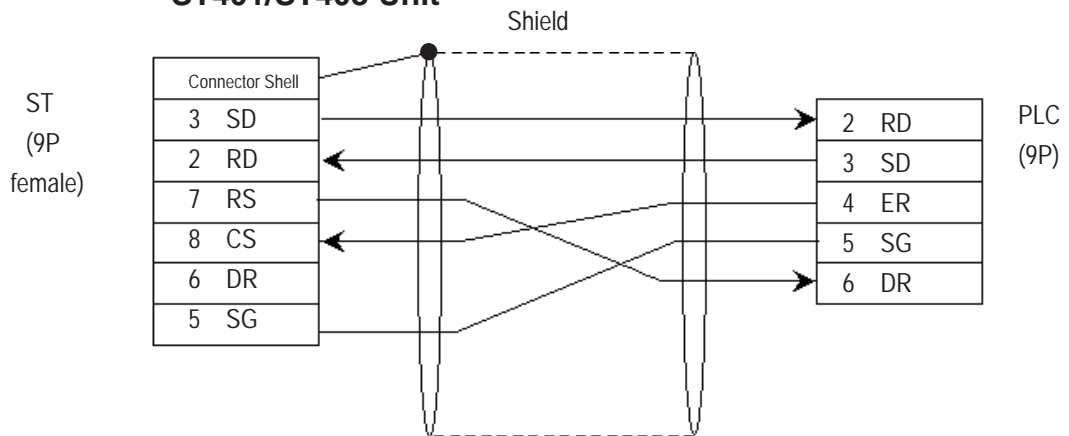

### Cable Diagram 7



- A termination resistance of  $330\Omega$  is needed between the PLC connector's SDA and SDB, and also between RDA and RDB.
- When using the FX2N-485-BD, FX1N-485-BD or FX3U-485-BD, be sure the cable is less than 50 meters.
- With the FX3UC, the PLC unit's termination resistance is built in to the FX3U-485-BD expansion board. When using a 4-wire system, be sure to change the unit's dip switch to  $330\Omega$ .

### GP/GLC Series Units

- When using Digital's RS-422 connector terminal adapter GP070-CN10-O

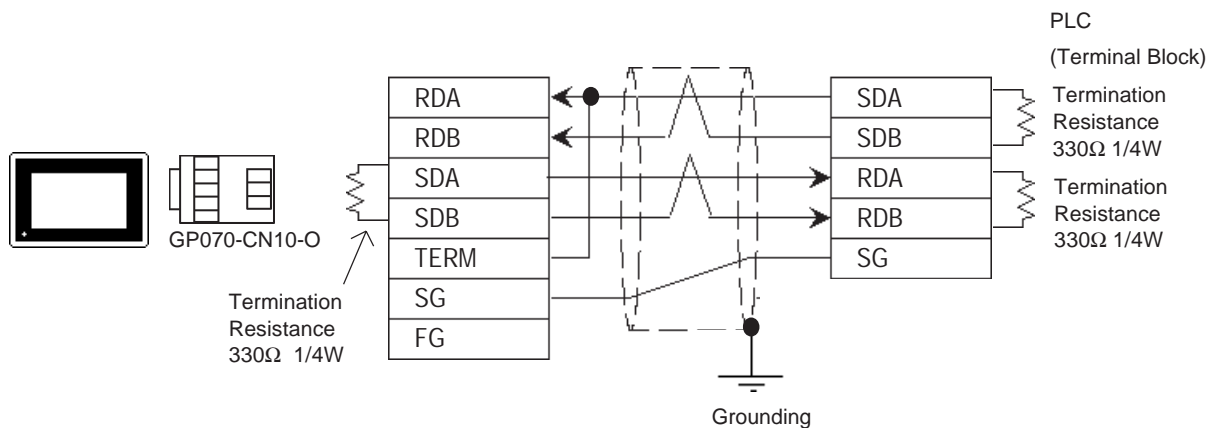

- When using Digital's RS-422 connector terminal adapter GP230-IS11-0

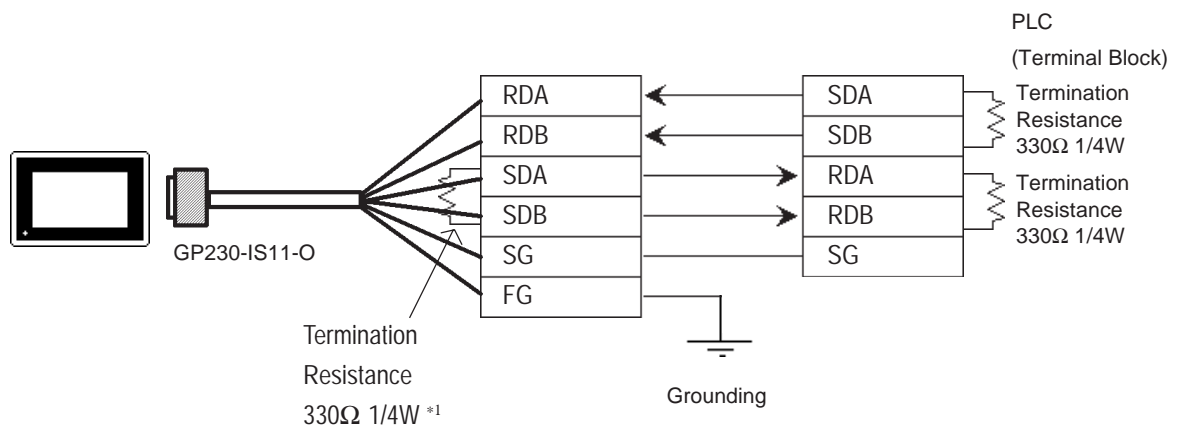

\*1 When extending the length of the cable, be sure to insert termination resistance between SDA and SDB.

- When making your own cable

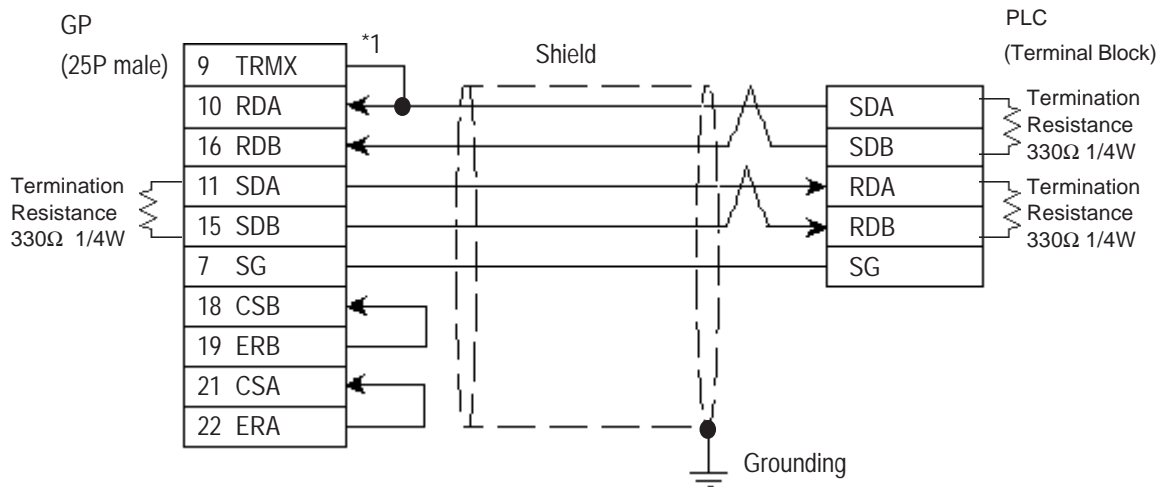

\*1 When connecting the #9 and #10 pins in the GP Serial I/F, a termination resistance of 100Ω is added between RDA and RDB.



**Digital recommends Mitsubishi Electric's SPEV(SB)-MPC-0.2x3P cable for this connection.**

### ST400/ST403 Unit

- When using Digital's RS-422 cable CA3-CBL422/5M-01

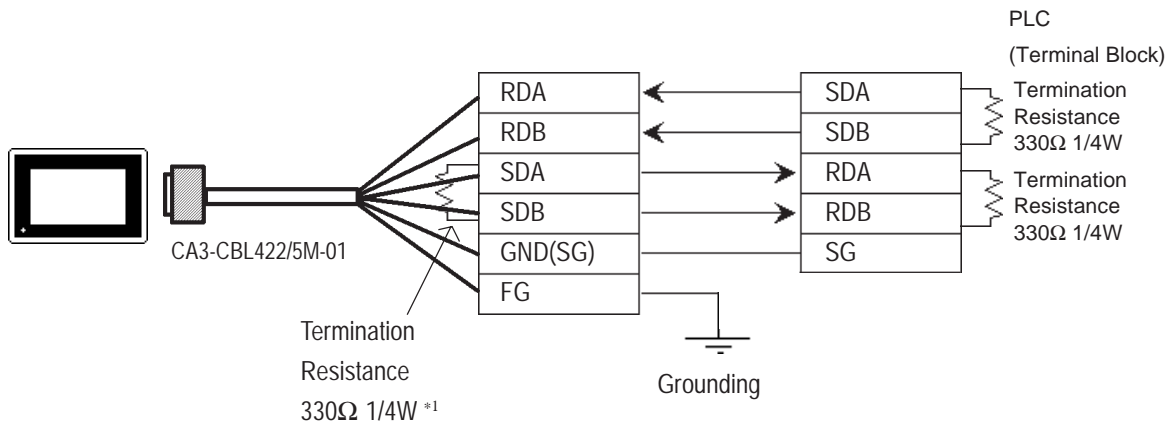

\*1 When extending the length of the cable, be sure to insert termination resistance between SDA and SDB.



**Be sure to connect the FG line to the FG terminal. For information about FG connections, refer to page 1-5 note \*1, in the "Connecting a Device/PLC to the ST unit."**

- When making your own cable

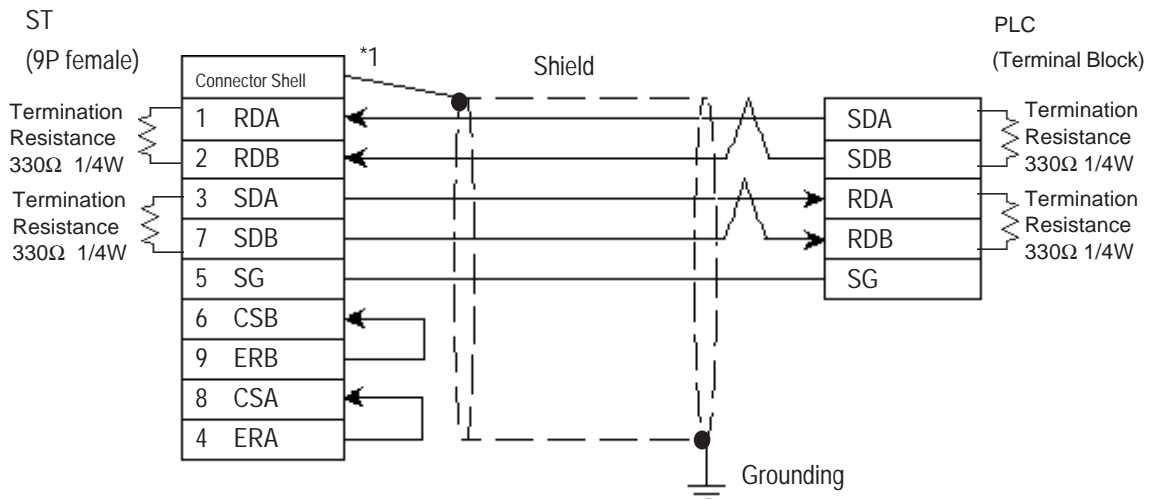

\*1 Be sure to connect the shield to the Connector Shell. For information about FG connections, refer to page 1-2 "RS422 I/F (ST400/ST403)" section's Note, in the "Connecting a Device/PLC to the ST unit."



**Note:** Digital recommends Mitsubishi Electric's SPEV(SB)-MPC-0.2x3P cable for this connection.

### Cable Diagram 8 (RS-232C)

#### GP/GLC Series Units

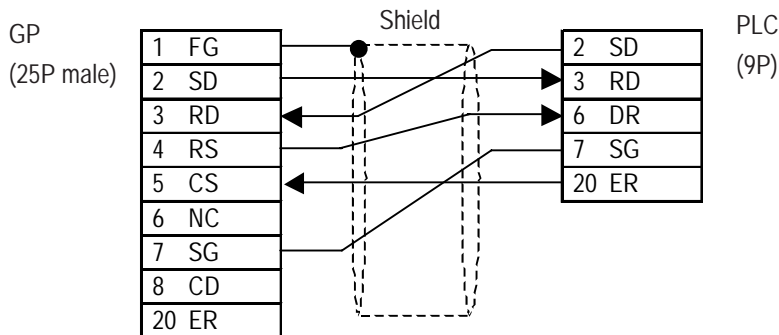

#### ST401/ST403 Unit

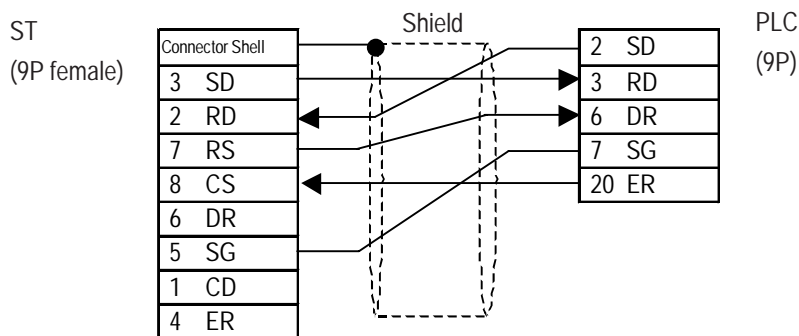

### Cable Diagram 9



- **Attaching a Ferrite Core will reduce the amount of noise in your cable.**
- **Attach two (2) Ferrite Cores to your cable, one at each end. Also, as shown in the drawing below, loop the cable once around the Ferrite Core.**
- **When using a data communication cable that is 3m(approx. 10ft.) or longer, please use a cable made by the Diatrend company.**
- **Be sure all cables are less than 15 meters long.**

### GP/GLC Series Units

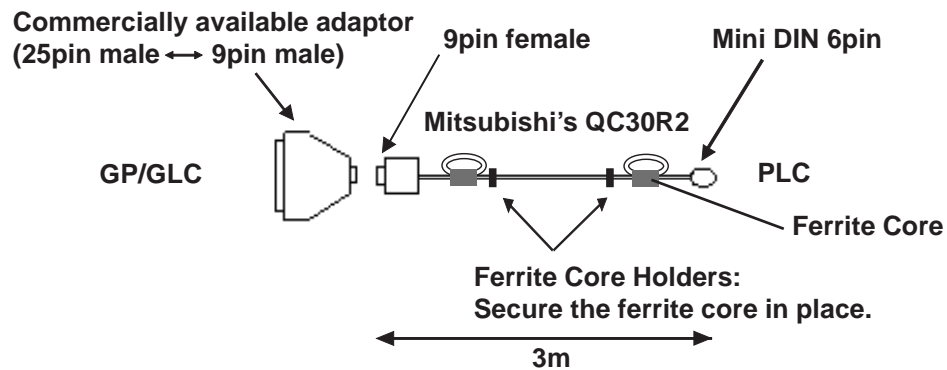

<Recommended Ferrite Core>

Maker :Seiwa Electronics Corporation

Model :E04SR301334

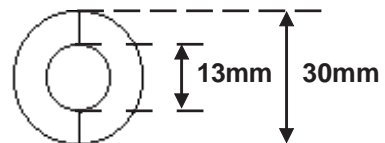
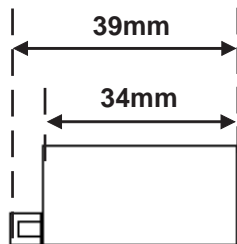



Conversion Adaptor Specifications

- Straight connection type
- D-Sub 25pin male Lock-screw (mm)
- D-Sub 9pin male Lock nut (inch)

<Adaptor : Roas Co. Model No. ZA-403>

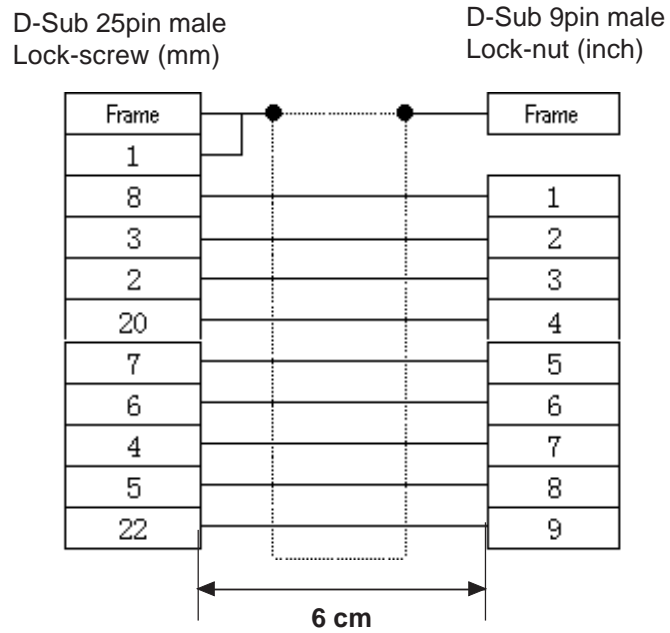

**ST401/ST403 Unit**

The ST 401/ST403 unit does not require this adaptor and can be connected directly to PLC.

## Cable Diagram 10



- **Attaching a Ferrite Core will reduce the amount of noise in your cable.**
- **Attach two (2) Ferrite Cores to your cable, one at each end. Also, as shown in the drawing below, loop the cable once around the Ferrite Core.**
- **When using a data communication cable that is 5m(approx. 10ft.) or longer, please use a cable made by the Diatrend company.**
- **Be sure all cables are less than 15 meters long.**

## GP/GLC Series Units

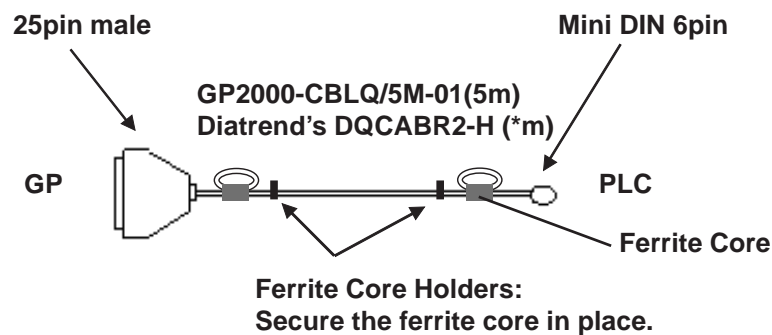

<Recommended Ferrite Core>

Maker :Seiwa Electronics Corporation

Model :E04SR301334

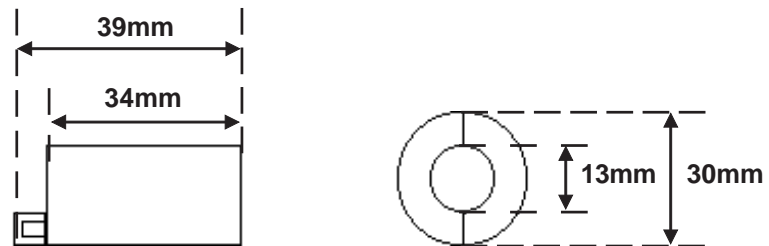

Other manufacturer's ferrite cores can be also used. (The size should be the same as shown here. )

## ST401/ST403 Unit

The DQCABR2-H requires a commercial-type conversion adaptor, such as one of the types listed below. Wiring is the same as shown for the conversion adaptor on page 30.

The CA3-CBLQ-01 does not require this adaptor and can be connected directly to PLC.

<Conversion Adaptor Specifications>

- Straight wiring type
- D-sub 9-pin female, with lock screw (inch)
- D-sub 25-pin female, with lock nut (mm)

### Cable Diagram 11



These cable diagrams can only be used for GP2000/GLC2000 Series units and the ST400/ST403 unit.

#### GP/GLC Series Units

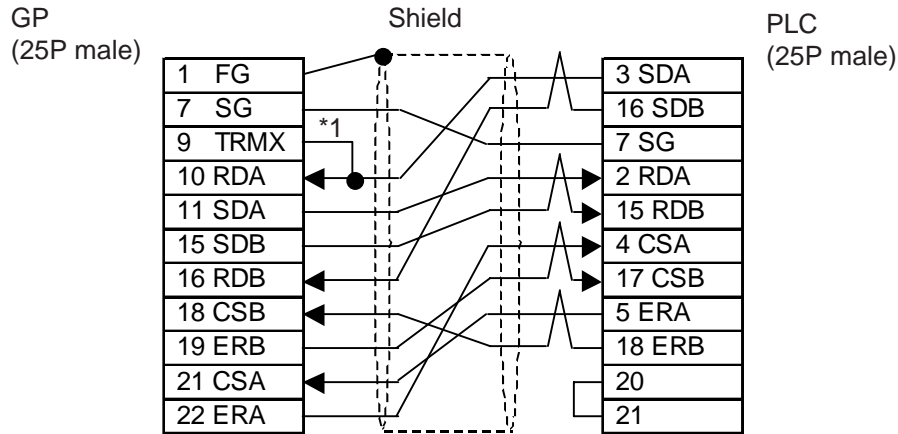

\*1 When connecting the #9 and #10 pins in the GP Serial I/F, a termination resistance of 100Ω is added between RDA and RDB.

#### ST400/ST403 Unit

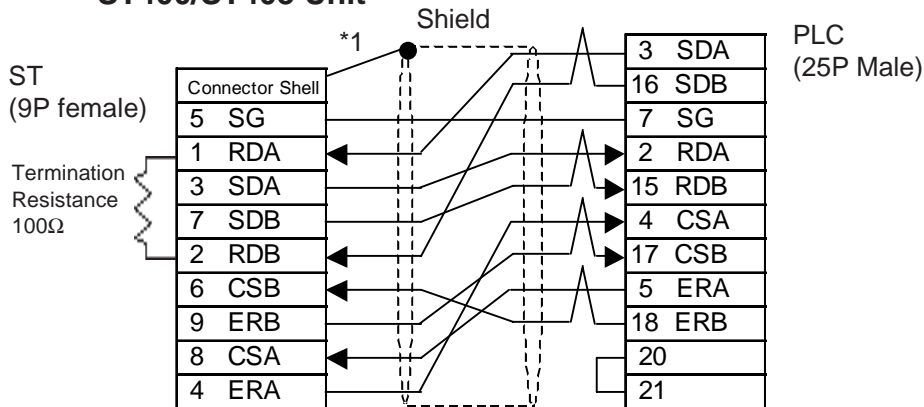

\*1 Be sure to connect the shield to the Connector Shell. For information about FG connections, refer to page 1-2 "RS422 I/F (ST400/ST403)" section's Note, in the "Connecting a Device/PLC to the ST unit."

### Cable Diagram 12 (RS-422)

The cable diagrams given below are for the option cables, however be sure to use an option cable when connecting to the Device/PLC.

- Using a GP2000-CBLFX/5M-01, GP2000-CBLFX/1M-01 cable

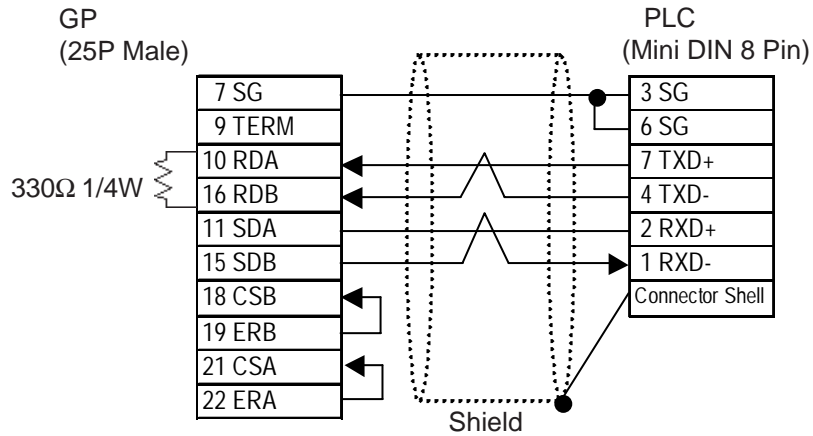

- Using a CA3-CBLFX/5M-01, CA3-CBLFX/1M-01 cable

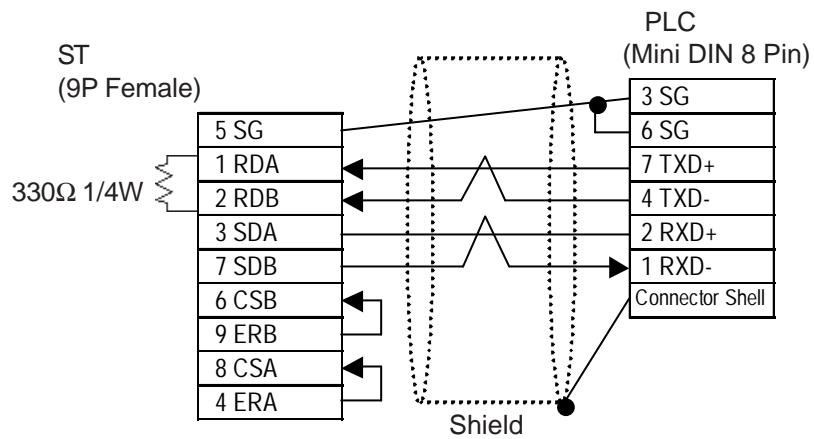

### Cable Diagram 13



- Connect a terminating resistor to both ends of the cable.
- When using only the FX0N-485ADP, the maximum cable length is 500m. When the FX1N-485-BD, FX2N-485-BD or FX3U-485-BD are included, the maximum cable length is 50m.
- As a general rule, connect the PLC at the end of the circuit's wiring (see below).
- With the FX3UC, the PLC unit's termination resistance is built into the FX3U-485-BD expansion board. When using a 4-wire system, be sure to change the unit's dip switch to 330Ω.

### GP/GLC Series Units

- When using Digital's RS-422 connector terminal adapter GP070-CN10-0

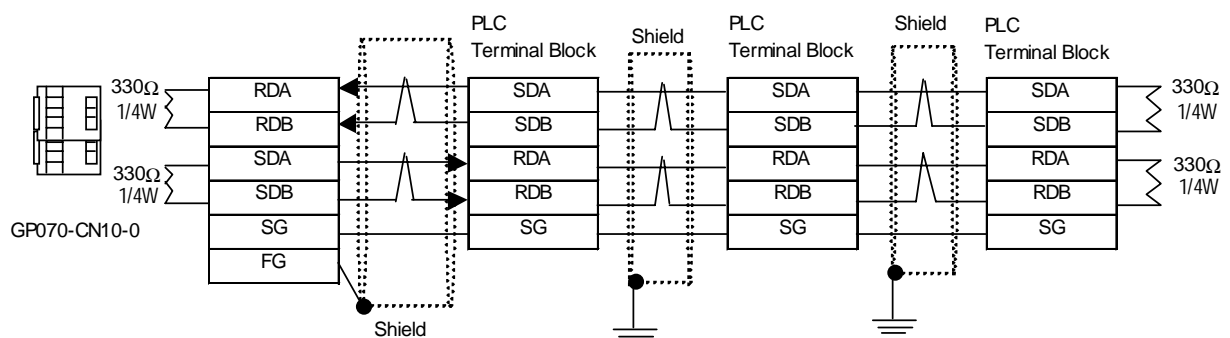

- When making your own cable

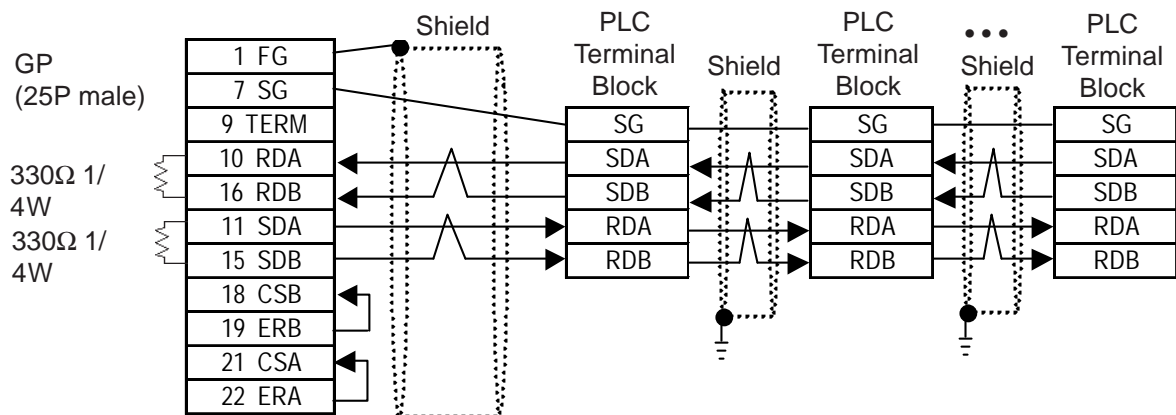

### ST400/ST403 Unit

- When making your own cable

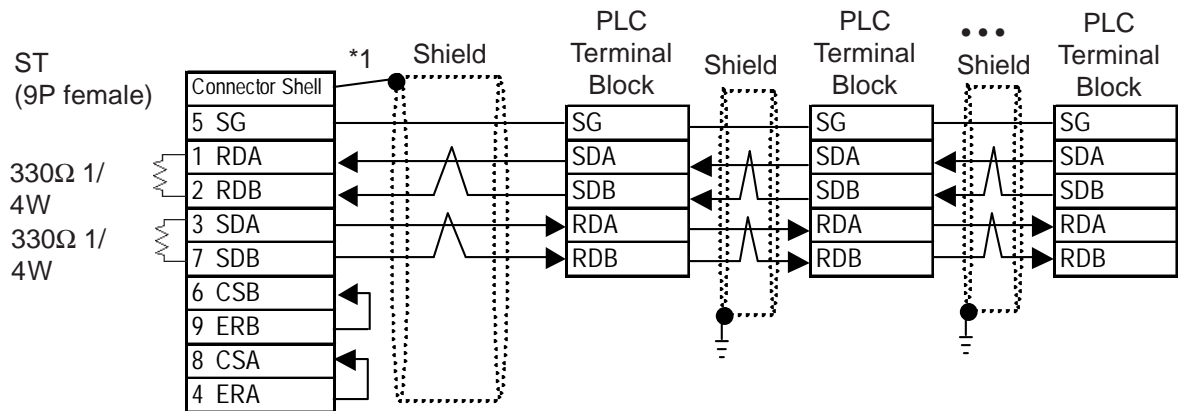

\*1 Be sure to connect the shield to the Connector Shell. For information about FG connections, refer to page 1-2 "RS422 I/F (ST400/ST403)" section's Note, in the "Connecting a Device/PLC to the ST unit."

**Cable Diagram 14 (RS-422 2-wire)**



- **Connect a terminating resistor to both ends of the cable.**
- **When using only the FX0N-485ADP, the maximum cable length is 500m. When the FX1N-485-BD, FX2N-485-BD or FX3U-485-BD are included, the maximum cable length is 50m.**
- **As a general rule, connect the PLC at the end of the circuit's wiring (see below).**
- **With the FX3UC, the PLC unit's termination resistance is built into the FX3U-485-BD expansion board. When using a 2-wire system, be sure to change the unit's dip switch to 110Ω.**

**GP/GLC Series Units**

- When using Digital's RS-422 connector terminal adapter GP070-CN10-O

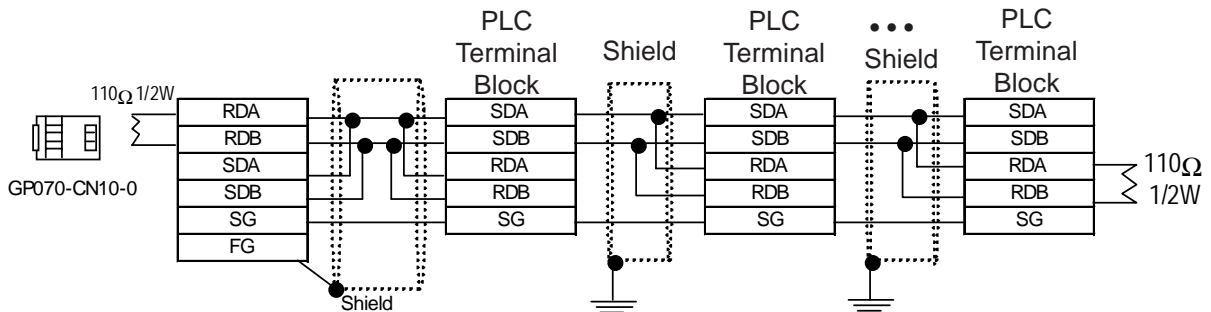

- When making your own cable

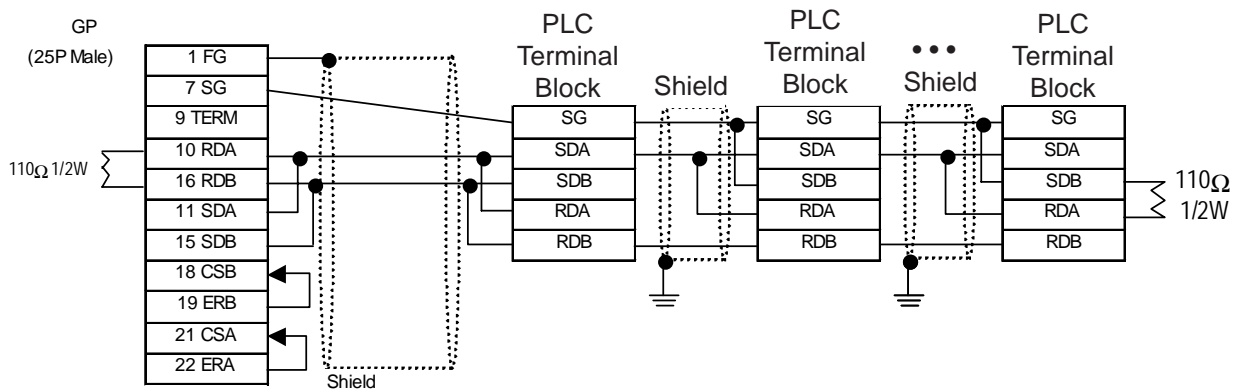

## ST400/ST403 Unit

- When making your own cable

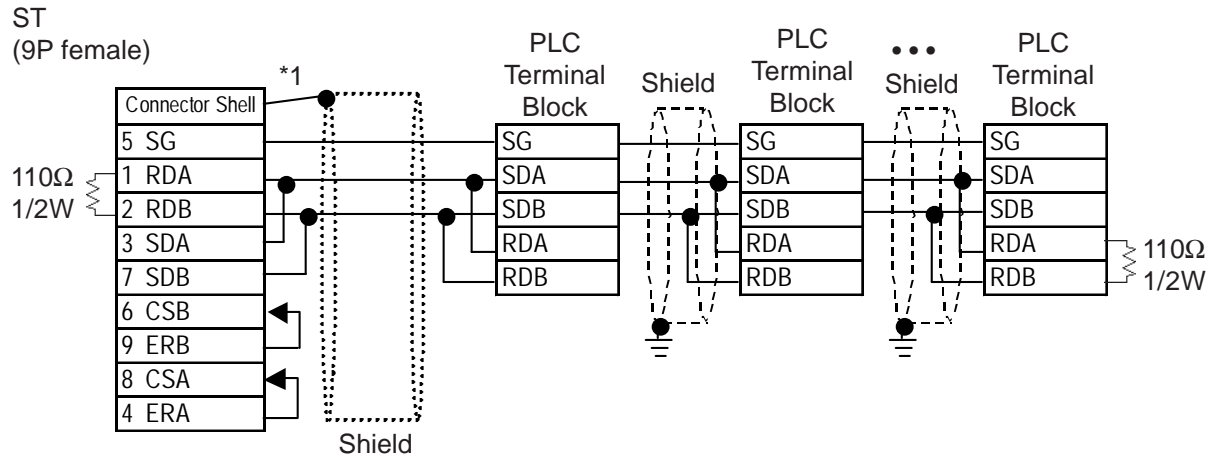

*\*1 Be sure to connect the shield to the Connector Shell. For information about FG connections, refer to page 1-2 "RS422 I/F (ST400/ST403)" section's Note, in the "Connecting a Device/PLC to the ST unit."*



### Cable Diagram 15

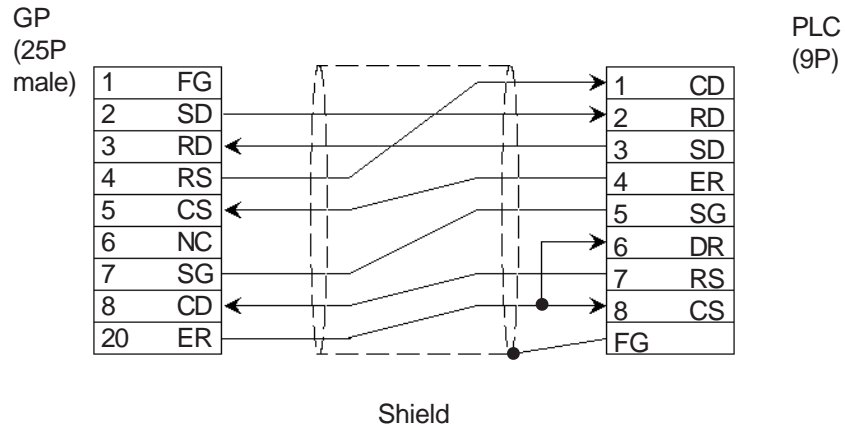

Be sure to connect the shield line to the PLC unit's terminal block FG terminal.

### Cable Diagram 16

- When using Digital's RS-422 connector terminal adapter GP070-CN10-0

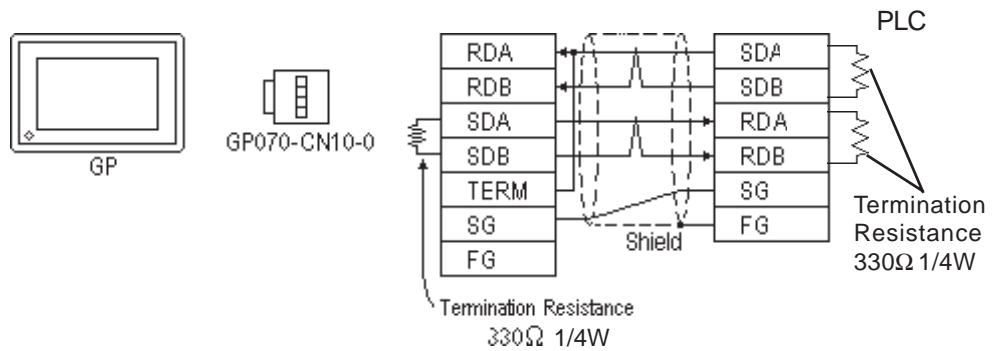

- When using Digital's RS-422 Cable, GP230-IS11-0

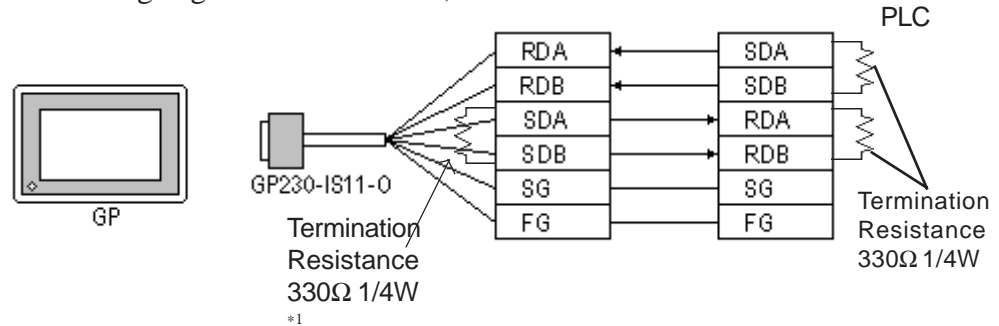

\*1 When extending the length of the cable, be sure to insert termination resistance between SDA and SDB.

- When making your own cable connections

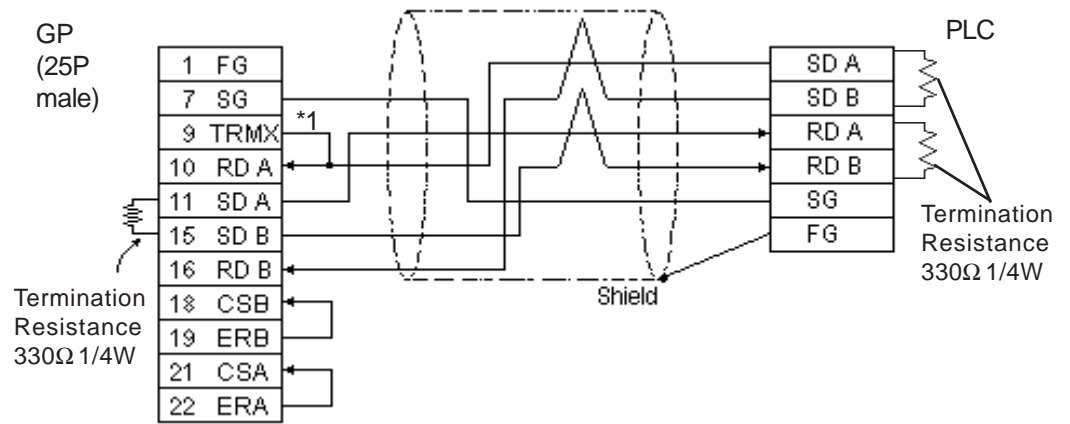











\*1 When connecting the #9 and #10 pins in the GP Serial I/F, a termination resistance of 100Ω is added between RDA and RDB.

## 2.1.3 Supported Devices

The following table describes the range of devices supported by the GP.

### ■ MELSEC-A Series (AnA/ AnU/ A2US/ A2USH-S1)

 Setup System Area here.

Device	Bit Address	Word Address	Particulars	
Input Relay	X0000 ~ X1FFF	X0000 ~ X1FF0		L/H
Output Relay	Y0000 ~ Y1FFF	Y0000 ~ Y1FF0		
Internal Relay	M0000 ~ M8191	M0000 ~ M8176		
Latch Relay	L0000 ~ L8191	L0000 ~ L8176		
Special Relay	M9000 ~ M9255	M9000 ~ M9240		
Annunciator	F0000 ~ F2047	F0000 ~ F2032		
Link Relay	B0000 ~ B1FFF	———		
Timer (contact)	TS0000 ~ TS2047	———		
Timer (coil)	TC0000 ~ TC2047	———		
Counter (contact)	CS0000 ~ CS1023	———		
Counter (coil)	CC0000 ~ CC1023	———		
Timer (current value)	———	TN0000 ~ TN2047		
Counter (current value)	———	CN0000 ~ CN1023		
Data Register	———	 D0000 ~ D8191		
Special Register	———	D9000 ~ D9255		
Link Register	———	W0000 ~ W1FFF		
File Register	———	R0000 ~ R8191	 *1	

\*1 When using the File Register on AnA or AnU, use the User's Memory area in the memory cassettes listed below.

A3NMCA-0    A3NMCA-2    A3NMCA-4    A3NMCA-8

A3NMCA-16    A3NMCA-24    A3NMCA-40    A3NMCA-56

A4UMCA-8E (only when using CPU Direct Communication)

When the File Register is setup and the memory cassette is not in use, an error will develop when communicating.



**If a ladder program is stored in ROM when a direct connection is used, there may be cases where the file register may not be used.**

## ■ MELSEC-N Series (AnN/ A2C/ A1S/ A3H/A0J2/A1SJ/A2SH/A1SH/A2CJ-S3)

     Setup System Area here.

Device	Bit Address	Word Address	Particulars	
Input Relay	X0000 ~ X07FF	X0000 ~ X07F0	<span style="border: 1px solid black; padding: 2px;">***0</span>	L/H
Output Relay	Y0000 ~ Y07FF	Y0000 ~ Y07F0	<span style="border: 1px solid black; padding: 2px;">***0</span> *1	
Internal Relay	M0000 ~ M2047	M0000 ~ M2032	<span style="border: 1px solid black; padding: 2px;">÷16</span>	
Latch Relay	L0000 ~ L2047	—		
Special Relay	M9000 ~ M9255	M9000 ~ M9240	<span style="border: 1px solid black; padding: 2px;">÷16</span> *2	
Annunciator	F000 ~ F255	F000 ~ F240	<span style="border: 1px solid black; padding: 2px;">÷16</span>	
Link Relay	B0000 ~ B03FF	—		
Timer (contact)	TS000 ~ TS255	—		
Timer (coil)	TC000 ~ TC255	—		
Counter (contact)	CS000 ~ CS255	—		
Counter (coil)	CC000 ~ CC255	—		
Timer (current value)	—	TN000 ~ TN255		
Counter (current value)	—	CN000 ~ CN255		
Data Register	—	D0000 ~ D1023	<span style="border: 1px solid black; padding: 2px;">Bit 15</span>	
Link Register	—	W0000 ~ W03FF	<span style="border: 1px solid black; padding: 2px;">Bit F</span>	
File Register	—	R0000 ~ R8191	<span style="border: 1px solid black; padding: 2px;">Bit 15</span> *3	

\*1 With the A2C, the Output Relays Y01F0~Y01FF (the word is Y01F0) cannot be setup for use on the PLC (only for A2C).

\*2 MELSEC-AnN and AJ71C24-S3 (or AJ71C24) cannot be matched and used.

\*3 When using the File Register on AnN or A3H, use the User's Memory area in the memory cassettes listed below.

A3NMCA-0    A3NMCA-2    A3NMCA-4    A3NMCA-8

A3NMCA-16    A3NMCA-24    A3NMCA-40    A3NMCA-56

A4UMCA-8E (only when using CPU Direct Connection)

When the File Register is setup when the memory cassette is not in use, an error will develop when communicating.



**Caution**

**If a ladder program is stored in ROM when a direct connection is used, there may be cases where the file register can not be used.**

## ■ MELSEC-F<sub>2</sub> Series (Using Link I/F)



Setup System Area here.

Device	Bit Address	Word Address	Particulars
Input Relay (X)	000 ~ 013, 400 ~ 413, 500 ~ 513	—	
Output Relay (Y)	030 ~ 037, 430 ~ 437, 530 ~ 537	—	
Timer (contact)(T)	050 ~ 057, 450 ~ 457, 550 ~ 557, 650 ~ 657	—	
Counter (contact)(C)	060 ~ 067, 460 ~ 467, 560 ~ 567, 660 ~ 667	—	
Hold Relay (M)	070 ~ 077, 100 ~ 177, 200 ~ 277, 470 ~ 477, 570 ~ 577	—	
Keep Relay (M)	300 ~ 377	—	
State (S)	800 ~ 877, 900 ~ 977, 600 ~ 647	—	
Timer (current value)	—	TC050 ~ TC057 TC450 ~ TC457 TC550 ~ TC557 TC650 ~ TC657	
Timer (set value)	—	TS050 ~ TS057 TS450 ~ TS457 TS550 ~ TS557 TS650 ~ TS657	
Counter (current value)	—	CC060 ~ CC067 CC460 ~ CC467 CC560 ~ CC567 CC660 ~ CC667	
Counter (set value)	—	CS060 ~ CS067 CS460 ~ CS467 CS560 ~ CS567 CS660 ~ CS667	
Data Register	—	DW700 ~ DW777	

**Note:**





Since the word addresses in F<sub>2</sub> Series' *Timer, Counter, and Data Register* bit length is 12, some tag functionality ( i.e. N-tag, S-tag, C-tag, etc.) is limited.



You cannot use 2 word (32 bit) data.











## ■ MELSEC-FX Series (using CPU Direct Connection and Mitsubishi's MELSEC-FX (CPU) Protocol on FX<sub>0</sub>)

 Setup System Area here.

Device	Bit Address	Word Address	Particulars	
Input Relay	X000 ~ X017	X000		L/H
Output Relay	Y000 ~ Y015	Y000		
Internal Relay	M000 ~ M511	M000 ~ M496		
State	S000 ~ S063	S000 ~ S048		
Timer (contact)	TS000 ~ TS055	—		
Counter (contact)	CS000 ~ CS015	—		
Timer (current value)	—	TN000 ~ TN055		
Counter (current value)	—	CN000 ~ CN015		
Data Register	—	D000 ~ D031		

## ■ MELSEC-FX Series (using Mitsubishi's MELSEC-FX2 (LINK) Protocol)

 Setup System Area here.

Device	Bit Address	Word Address	Remarks	
Input Relay	X0000 - X0377	X0000 - X0360	 	L/H
Output Relay	Y0000 - Y0377	Y0000 - Y0360	 	
Auxiliary Relay	M0000 - M7679	M0000 - M7664		
State	S0000 - S4095	S0000 - S4080		
Special Auxiliary relay	M8000 - M8511	M8000 - M8496	 *1	
Timer (contact)	TS000 - TS511	—		
Counter (contact)	CS000 - CS255	—		
Timer (current)	—	TN000 - TN511		
Counter (current)	—	CN000 - CN255	*2	
Data Register	—	D0000 - D7999		
Special Data Register	—	D8000 - D8511	 *1 *3	
Extended Register	—	R00000 - R32767	 *4 *3	

\*1 The Special Auxiliary Relay and the Special Data Register are divided into three areas. These are the Exclusive Reading Area, the Exclusive Writing Area and the System Area. For details, refer to your PLC's manual.

\*2 Word addresses CN200 to CN255 are 32 bit counters.







\*3 When designating data register addresses, be sure that they do not overlap with the special register area. For example, do not perform a write of two or more words, starting from "D7999".

When a write of two or more words is done starting from "D7999", a "Host Communication" error (02:FA) occurs.

\*4 With only FX3UC, FX3U units.

## ■ MELSEC-FX Series (using Mitsubishi's MELSEC-FX (CPU) or MELSEC-FX (CPU2) Protocol)

 Setup System Area here.

Device	Bit Address	Word Address	Remarks	
Input Relay	X000 - X0377	X000 - X0360	 *2	L/H
Output Relay	Y000 - Y0377	Y000 - Y0360	 *2	
Internal Relay	M0000 - M7679	M0000 - M7664	 *3	
Special Auxiliary relay	M8000 - M8511	M8000 - M8496	 *3	
State	S000 - S4095	S000 - S4080		
Timer (contact)	TS000 - TS511	—————		
Counter (contact)	CS000 - CS255	—————		
Timer (current value)	—————	TN000 - TN511		
Counter (current value)	—————	CN000 - CN255	*1	
Data Register	—————	D000 - D7999	 *4 *5	
Special Data Register	—————	D8000 - D8511	 *3	
Extended Register	—————	R00000 - R32767	 *6	

\*1 Addresses CN200 to CN255 are 32 bits long.

\*2 Cannot perform data write.

\*3 The Special Auxiliary Relay and the Special Data Register are divided into three areas. These are the Exclusive Reading Area, the Exclusive Writing Area and the System Area. For details, refer to your PLC's manual.

\*4 When designating data register addresses, be sure that they do not overlap with the special register area.

For example, do not perform a write of two or more words, starting from "D7999".

When a write of two or more words is done starting from "D7999", a "Host Communication" error (02:FA) occurs.

\*5 For the FX1S series and FX0N series, addresses D1000 to D2499 are file registers.

File registers can be used based on the file data amount designated through the ladder program.

When this amount is not specified, a "Host Communication" error (02:FA) occurs.

When changing the PLC's file data amount settings during GP-PLC communication, be sure to turn ON/OFF the GP unit's power. As long as the screen is not changed to a different one, the screen's file register will continue to access the memory value that was designated before the change.









\*6 With only FX3UC, FX3U units.



**Refer to the MELSEC-N series manuals for the A1FX's range of available devices.**

## ■ MELSEC-FX Series (using Mitsubishi's MELSEC-FX 1 : n Connection Protocol)

 Setup System Area here.

Device	Bit Address	Word Address	Remarks	
Input Relay	X0000 - X0377	X0000 - X0360		L/H
Output Relay	Y0000 - Y0377	Y0000 - Y0360		
AUX Relay	M0000 - M7679	M0000 - M7664		
Special AUX Relay	S0000 - S4095	S0000 - S4080		
State	M8000 - M8511	M8000 - M8496	 *3	
Timer (contact)	TS000 - TS511	—————		
Counter (contact)	CS000 - CS255	—————		
Timer (current value)	—————	TN000 - TN511		
Counter (current value)	—————	CN000 - CN255	*1	
Data Register	—————	D0000 - D7999	 *3	
Special Data Register	—————	D8000 - D8511	 *2	
Extended Register	—————	R00000 - R32767	 *4 *5	

\*1 Addresses CN200 to CN255 are 32 bits long.

\*2 The Special Auxiliary Relay and the Special Data Register are divided into three areas. These are the Exclusive Reading Area, the Exclusive Writing Area and the System Area. For details, refer to your PLC's manual.

\*3 When designating data register addresses, be sure that they do not overlap with the special register area.

For example, do not perform a write of two or more words, starting from "D7999". When a write of two or more words is done starting from "D7999", a "Host Communication" error (02:FA) occurs.

\*4 Used only by FX3UC, FX3U.

\*5 (Only when using Mitsubishi Electric MELSEC-FX 1:N Communication Protocol)

The GP unit processes data internally in blocks of 8192 words. If data spans more than one block, the following features cannot be used. When using these features, be sure all data spans no more than a single block.

















- 1) a-Tag settings
- 2) 2-Way feature block readout/writing of data.

Ex. Using Pro-Server to perform a block readout of 20 words of data, starting from R8191.



■ MELSEC-QnA Series (using Computer Unit AJ71QC24/A1SJ71QC24/A1SJ71QC24N/ AJ71QC24N-R4/AJ71QC24N/A1SJ71QC24N1 or using CPU Direct Connection)

 Setup System Area here.

Device	Bit Address	Word Address	Particulars
Input Relay	X0000 - X1FFF	X0000 - X1FF0	
Output Relay	Y0000 - Y1FFF	Y0000 - Y1FF0	
Internal Relay	M00000 - M32767	M00000 - M32752	
Special Relay	SM0000 - SM2047	SM0000 - SM2032	
Latch Relay	L00000 - L32767	L00000 - L32752	
Annunciator	F00000 - F32767	F00000 - F32752	
Edge Relay	V00000 - V32767	V00000 - V32752	
Step Relay	S0000 - S8191	S0000 - S8176	
Link Relay	B0000 - B7FFF	B0000 - B7FF0	
Special Link Relay	SB000 - SB7FF	SB000 - SB7F0	
Timer (contact)	TS00000 - TS23087	———	
Timer (coil)	TC00000 - TC23087	———	
Aggregate Timer (contact)	SS00000 - SS23087	———	
Aggregate Timer (coil)	SC00000 - SC23087	———	
Counter (contact)	CS00000 - CS23087	———	
Counter (coil)	CC00000 - CC23087	———	
Timer (current value)	———	TN00000 - TN23087	
Aggregate Timer (current value)	———	SN00000 - SN23087	
Counter (current value)	———	CN00000 - CN23087	
Data Register	———	<b>D00000 - D25983</b>	
Special Data Register	———	SD0000 - SD2047	
Link Data Register	———	W0000 - W657F	
Special Link Register	———	SW000 - SW7FF	
File Register (normal)		R00000 - R32767	 *1
File Register (serial)		0R0000 - 0R7FFF (ZR0000 - ZR32767) : 1R0000 - 1R7FFF (ZR32768 - ZR65535)	 *1

L/H

\*1 When using File Register, a Memory Card is necessary.

Usable capacity of the File Register varies depending on the capacity of the Memory Card.



- Each device range represents the maximum range available, given the parameter settings.
- Depending on your CPU, the usable device type and range may differ. Before using only a CPU, refer to your CPU User Manual.

### ■ MELSEC-QnA Series (using Computer Unit AJ71UC24/A1SJ71UC24/A1SJ71UC24-R2/A1SJ71UC24-R4)

     Setup System Area here.

Device	Bit Address	Word Address	Particulars
Input Relay	X0000 ~ X03FF	X0000 ~ X03F0	<span style="border: 1px solid black; padding: 2px;">***0</span>
Output Relay	Y0000 ~ Y03FF	Y0000 ~ Y03F0	<span style="border: 1px solid black; padding: 2px;">***0</span>
Internal Relay	M00000 ~ M8191	M00000 ~ M8176	<span style="border: 1px solid black; padding: 2px;">÷16</span>
Special Relay	SM1000 ~ SM1255	SM1000 ~ SM1240	<span style="border: 1px solid black; padding: 2px;">÷16</span> *1
Annunciator	F0000 ~ F2047	F0000 ~ F2032	<span style="border: 1px solid black; padding: 2px;">÷16</span>
Link Relay	B0000 ~ B0FFF	———	<span style="border: 1px solid black; padding: 2px;">***0</span>
Timer (contact)	TS0000 ~ TS2047	———	
Timer (coil)	TC0000 ~ TC2047	———	
Counter (contact)	CS0000 ~ CS1023	———	
Counter (coil)	CC0000 ~ CC1023	———	
Timer (current value)	———	TN0000 ~ TN2047	
Counter (current value)	———	CN0000 ~ CN1023	
Data Register	———	D0000 ~ D6143	<span style="border: 1px solid black; padding: 2px;">Bit15</span>
Special Data Register	———	SD1000 ~ SD1255	<span style="border: 1px solid black; padding: 2px;">Bit15</span> *1
Link Register	———	W0000 ~ W0FFF	<span style="border: 1px solid black; padding: 2px;">BitF</span>

L/H

\*1 Table data will change depending on whether the perspective is from the PLC or the User's PC.

Device	GP-PRO/PBIII	PLC Manual
Special Relay	M9000 ~ M9255	SM1000 ~ SM1255 (cannot use SM0000~SM0999)
Special Register	D9000 ~ D9255	SD1000 ~ SD1255 (cannot use SD0000~SD0999)

◆ **MELSEC-QnA series communications mode selection (when using a link unit)**

When using the MELSEC-QnA series unit, either mode 2 or mode 1 can be selected during the entering of the initial settings, when the GP is in the OFFLINE mode.

**Mode 2:** This is a new communications mode. It is enabled when less than 64 devices have been designated by a single screen's tags. The communications speed has been improved. Select this mode when using less than 64 devices.











**Mode 1:** This mode is equivalent to the communications mode used previously. This mode is valid for 64 or more devices have been specified by a single screen's tags. The communications speed has been improved. Select this mode when using 64 or more devices.

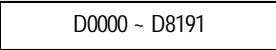

- ***If the on-screen data memory area in the GP is initialized or if the on-screen data is transferred from the drawing software, the GP returns to mode 1 (its initial setting). Use the offline settings area to select mode 2.***
- ***In mode 2, the communications speed may not always be improved depending on which tags and system area are used, as well as how the PLC's read areas are allocated.***

## ■ MELSEC-Q Series (A mode, CPU Direct Connection)



















 Setup System Area here.

Device	Bit Address	Word Address	Particulars	
Input Relay	X0000 ~ X1FFF	X0000 ~ X1FF0		L/H
Output Relay	Y0000 ~ Y1FFF	Y0000 ~ Y1FF0		
Internal Relay	M0000 ~ M8191	M0000 ~ M8176		
Latch Relay	L0000 ~ L8191	L0000 ~ L8176		
Special Relay	M9000 ~ M9255	M9000 ~ M9240		
Annunciator	F0000 ~ F2047	F0000 ~ F2032		
Link Relay	B0000 ~ B1FFF	———		
Timer (contact)	TS0000 ~ TS2047	———		
Timer (coil)	TC0000 ~ TC2047	———		
Counter (contact)	CS0000 ~ CS1023	———		
Counter (coil)	CC0000 ~ CC1023	———		
Timer (current value)	———	TN0000 ~ TN2047		
Counter (current value)	———	CN0000 ~ CN1023		
Data Register	———			
Special Data Register	———	D9000 ~ D9255		
Link Register	———	W0000 ~ W1FFF		
File Register	———	R0000 ~ R8191	 *1	

\* 1 The amount of space available when using the File Register will vary, depending on the amount of CPU ROM/RAM available, or the amount of memory available on the memory card.

## ■ MELSEC-Q Series (Q mode Link I/F, CPU Direct)

 Setup System Area here.

Device	Bit Address	Word Address	Notes	
Input Relay	X0000 ~ X1FFF	X0000 ~ X1FF0		L/H
Output Relay	Y0000 ~ Y1FFF	Y0000 ~ Y1FF0		
Internal Relay	M00000 ~ M32767	M00000 ~ M32752		
Special Relay	SM0000 ~ SM2047	SM0000 ~ SM2032		
Latch Relay	L0000 ~ L32767	L0000 ~ L32752		
Annunciator	F0000 ~ F32767	F0000 ~ F32752		
Edge Relay	V0000 ~ V32767	V0000 ~ V32752		
Step Relay	S0000 ~ S8191	S0000 ~ S8176		
Link Relay	B0000 ~ B7FFF	B0000 ~ B7FF0		
Special Link Relay	SB000 ~ SB7FF	SB000 ~ SB7F0		
Timer (contact)	TS00000 ~ TS23087	———		
Timer (coil)	TC00000 ~ TC23087	———		
Aggregate Timer (contact)	SS00000 ~ SS23087	———		
Aggregate Timer (coil)	SC00000 ~ SC23087	———		
Counter (contact)	CS00000 ~ CS23087	———		
Counter (coil)	CC00000 ~ CC23087	———		
Timer (current value)	———	TN00000 ~ TN23087		
Aggregate Timer (current value)	———	SN00000 ~ SN23087		
Counter (current value)	———	CN00000 ~ CN23087		
Data Register	———	D00000 ~ D25983		
Special Data Register	———	SD0000 ~ SD2047		
Link Data Register	———	W0000 ~ W657FF		
Special Link Register	———	SW000 ~ SW7FF		
File Register (normal)	———	R00000 ~ R32767	 *1	
File Register (serial)	———	0R0000 ~ 0R7FFF (ZR0000 ~ ZR32767)	 *1	
	———	1R0000 ~ 1R7FFF (ZR32768 ~ ZR65535)	 *1	
	:	:	:	
	———	31R0000 ~ 31R67FF (ZR1015808 ~ ZR1042431)	 *1	

\*1 The amount of space available when using the File Register will vary, depending on the amount of CPU ROM/RAM available, or the amount of memory available on the memory card.



- Each device range represents the maximum range available, given the parameter settings.
- Depending on your CPU, the usable device type and range may differ. Before using only a CPU, refer to your CPU User Manual.

## 2.1.4 Environment Setup

The following lists Digital's recommended PLC and GP communication settings.



- Items affecting the PLC program cycle -
- Please be aware that PLC program cycle time slows by approximately 8% when you connect the GP to the programming port and begin communications with the GP.

### ■ MELSEC-A Series / N Series (using Calculation Link Unit)

GP Setup		Computer Link Unit Settings	
Baud Rate	19200 bps	Baud Rate	19200 bps
Data Length	7 bits	Data Bit	7 bits
Stop Bit	2 bits	Stop Bit	2 bits
Parity Bit	Even	Parity Check Parity setting even/odd	Yes Even
Data Flow Control	ER Control	---	
Communication Format (RS-232C)	RS-232C	Channel Setup <sup>*1</sup> Mode Setup (RS-232C)	RS-232C 4 (Format 4 protocol)
Communication Format (RS-422)	4-wire type	Channel Setup <sup>*1</sup> Mode Setup (RS-422)	RS-422 8 (Format 4 protocol)
---		Write possible in RUN mode.	Possible
---		Sum Check	Yes
---		Enable Sender Termination Resistor <sup>*2</sup>	Yes
---		Enable Receiver Termination Resistor <sup>*2</sup>	Yes
Unit No.	0	Station Number	0

\*1 A1SJ71C24-R2, A1SJ71UC24-R2, and A1SJ71C24-R4 do not have this setting.

\*2 The A171UC24 does not have this setting.

■ MELSEC-A Series / N Series (CPU Direct Connection)

GP Setup		PLC Settings
Baud Rate	9600 bps (fixed)	---
Data Length	8 bit (fixed)	---
Stop Bit	1 bit (fixed)	---
Parity Bit	Odd (fixed)	---
Data Flow Control	ER Control	---
Communication Format <sup>*1</sup> (RS-232C)	RS-232C	---
Communication Format (RS-422)	4-wire type	---
Unit No.	0 (fixed)	---

*\*1 Only when using Digital's Programming Console I/F cable (GP430-IP10-O) for the MELSEC-A Series unit or a Diatrend Co. DAFXIH-CABV cable. Otherwise, a 4-wire type cable is required.*

■ MELSEC-A2C

GP Setup		A2C Settings	
Baud Rate	19200 bps	Baud Rate	19200 bps
Data Length	8 bits	Data Bit	8 bits
Stop Bit	1 bit	Stop Bit	1 bit
Parity Bit	Even	Parity Check Parity setting even/oddd	Yes Even
Data Flow Control	ER Control	---	
Communication Format	RS-232C	Channel Setup Mode Setup	RS-232C 4 (Format 4 protocol)
---		Write possible in RUN mode	Possible
---		Sum Check	Yes
Unit No.	0	Station Number	0

■ MELSEC-F<sub>2</sub> Series

GP Setup		Interface Settings	
Baud Rate	9600 bps	Baud Rate	9600 bps
Data Length	7 bits	Data Bit	7 bits
Stop Bit	1 bit (fixed)	Stop Bit	1 bit (fixed)
Parity Bit	Even	Parity Bit	Even
Data Flow Control	ER Control	---	
Communication Format	RS-232C	---	
---		Resistor Setting	Yes
---		Sum Check	Yes
Unit No.	0	Station Number	0

■ **MELSEC-FX Series** (Mitsubishi's MELSEC-FX2 (LINK) Protocol - not using FX3UC, FX3U unit)

GP Setup		Computer Link Unit Settings	
Baud Rate	19200 bps	Baud Rate	19200 bps
Data Length	7 bits	Data Bit	7 bits
Stop Bit	2 bits	Stop Bit	2 bits
Parity Bit	Even	Parity Bit	Even
Data Flow Control	ER Control	---	
Communication Format (RS-232C)	RS-232C	Computer Link	RS-232C I/F
Communication Format (RS-422)	4-wire type	Computer Link	RS485 (RS422) I/F
Unit No.	0	Station Number <sup>*1</sup>	0
---		Sum Check	Yes
---		Protocol	Yes
---		Control Method	4
---		Header	No
---		Terminator	No

*\*1 Even though PLC station numbers are set using 00h to 0Fh, the GP Series units use only 0 to 7.*



- Note:**
- It is possible to enter PLC settings via the ladder software's PC system settings or to write data directly to data registers D8120 and D8121. For details, refer to Mitsubishi's "FX Communication User Manual".
  - For [Send Wait], set the value more than twice as the scanning time of PLC when connecting the GP Series units to FX0N, FX1S, FX1N and FX1NC Series.



■ **MELSEC-FX Series** (Mitsubishi's MELSEC-FX2 (LINK) Protocol - using FX3UC, FX3U unit)

GP Setup		Computer Link Unit Settings	
Baud Rate	19200 bps	Baud Rate	19200 bps
Data Length	7 bits	Data Bit	7 bits
Stop Bit	2 bits	Stop Bit	2 bits
Parity Bit	Even	Parity Bit	Even
Data Flow Control	ER Control	---	
Communication Format (RS-232C)	RS-232C	Computer Link	RS-232C I/F
Communication Format (RS-422)	4-wire type	Computer Link	RS485 (RS422) I/F
Unit No.	0	Station Number	0
---		Sum Check	Yes
---		Protocol	Yes
---		Control Method	4
---		Header	No
---		Terminator	No

\*1 The termination resistance will vary depending on if a 4-wire or a 2-wire connection is used. Termination resistance is built into the FX3U-485-BD expansion board.

\*2 Even though PLC station numbers are set using 00h to 0Fh, the GP Series units use only 0 to 7.



**It is possible to enter PLC settings via the ladder software's PC system settings or to write data directly to data registers D8120 and D8121. For details, refer to Mitsubishi's "FX Communication User Manual".**

■ **MELSEC-FX Series** \*1 (using Mitsubishi's MELSEC-FX (CPU) or MELSEC-FX (CPU2) Protocol)

GP Setup		FX Series Settings
Baud Rate *2	9600 bps	---
Data Length	7 bits (fixed)	---
Stop Bit	1 bit (fixed)	---
Parity Bit	Even (fixed)	---
Data Flow Control	ER Control	---
Communication Format (When using Mitsubishi Melsec-FX(CPU) Protocol)	RS-232C	---
Communication Format (When using Mitsubishi Melsec-FX(CPU2) Protocol)	4-wire	---
Unit No.	0 (fixed)	---

\*1 When using the AIFX unit, use the same settings as those for the MELSEC-N Series (CPU Direct Connection).



**Caution**

**When using the expansion board with the above mentioned direct connection protocol, store "0" data in D8120. Also, when using the FX3UC or the FX3U, be sure to set M8070 and M8071 to OFF.**

\*2 If the version of MELSEC-FX(CPU2) protocol is lower than V1.43, 9600 bps is fixed. The version of the protocol can be checked in the main menu of the offline mode.

■ **MELSEC-FX Series** (Mitsubishi's MELSEC-FX 1:n Connection Protocol - not using FX3UC, FX3U unit)

GP Setup		PLC Settings	
Baud Rate	19200 bps	Baud Rate	19200 bps
Data Length	7 bits	Data Length	7 bits
Stop Bit	2 bits	Stop Bit	2 bits
Parity Bit	Even	Parity Bit	Even
Data Flow Control	ER	-----	
Communication Format	4-wire or 2-wire	H/W Type	RS-485
Unit No.	0	Station Number *1	0
-----		Use Comm. Settings	Use
-----		Sum Check	Yes
-----		Protocol	Special Protocol
-----		Control Method	4
-----		Header	None
-----		Terminator	None

\*1 Although 00H to 0FH can be used for the PLC station numbers, use only 0 to 7 for the GP Series unit.



**Note:**

**It is possible to enter PLC settings via the ladder software's PC system settings or to write data directly to data registers D8120 and D8121. For details, refer to Mitsubishi's "FX Communication User Manual".**

■ **MELSEC-FX Series** (Mitsubishi's MELSEC-FX 1:n Connection Protocol - using FX3UC, FX3U unit)

GP Setup		PLC Settings	
Baud Rate	19200 bps	Baud Rate	19200 bps
Data Length	7 bits	Data Length	7 bits
Stop Bit	2 bits	Stop Bit	2 bits
Parity Bit	Even	Parity Bit	Even
Data Flow Control	ER		ER
Communication Format	4-wire or 2-wire	H/W Type <sup>*1</sup>	RS-485
Unit No.	0	Station Number <sup>*2</sup>	00h
_____		CH	CH1
_____		Protocol	Special Protocol
_____		Control Method	4
_____		Sum Check	Added
_____		Comm. Settings	Use check
_____		Header	None
_____		Terminator	None

\*1 The termination resistance will vary depending on if a 4-wire or a 2-wire connection is used. Termination resistance is built into the FX3U-485-BD expansion board or the FX3U-485ADP expansion board.

\*2 Even though PLC station numbers are set using 00h to 0Fh, the GP Series units use only 0 to 7.



**It is possible to enter PLC settings via the ladder software's PC system settings or to write data directly to data registers D8120 and D8121. For details, refer to Mitsubishi's "FX Communication User Manual".**

■ MELSEC-QnA (using Serial Communication Unit)

GP Setup		Serial Communication Unit Settings	
Baud Rate	19200 bps <sup>*1</sup>	Baud Rate	19200 bps
Data Length	7 bits	Data Bit	7 bits
Stop Bit	2 bits	Stop Bit	2 bits
Parity Bit	Even	Parity Check Parity setting even/odd	Yes Even
Data Flow Control	ER Control	---	
Communication Format (RS-232C)	RS-232C	Mode Setup (RS-232C)	4 (Format 4 Protocol Mode)
Communication Format (RS-422)	4-wire type	Mode Setup (RS-422)	4 (Format 4 Protocol Mode)
---		Sum Check	Yes
---		Enable Sender Termination Resistor	Yes
---		Enable Receiver Termination Resistor	Yes
Unit No.	0	Station Number	0

\*1 AJ71QC24-R4 , A1SJ71QC24N and AJ71QC24N can use a baud rate of 115,200bps.



- When your environment setup involves using MELSEC-QnA and the Computer Link Unit AJ71UC24 together, refer to the MELSEC-A Series' table.
- Serial communication units CH1 and CH2 can communicate at the same time, given any of the following conditions are true.
  - Condition 1 : The sticker on the top of the communication unit indicates the version is AB or later.
  - Condition 2 : The date shown on the side of the communication unit indicates it was produced in September 1996 (9609) or later.
  - Condition 3 : The communication unit's ROM version is 7179M or later.

■ MELSEC-QnA (using Serial Communication Unit A1SJ71QC24N1)

GP Setup		Serial Communication Unit Settings <sup>*1</sup>	
Baud Rate	19200 bps	Baud Rate	19200 bps
Data Length	7 bits	Data Length	7 bits
Stop Bit	2 bits	Stop Bit	2 bits
Parity Bit	Even	Parity bit Even/Odd parity	Even
Control system	ER Control	---	
Communication method (RS-232C is used.)	RS-232C	---	
Communication method (RS-422 is used.)	4-wire type	---	
---		Sum check code	Enabled
Unit No.	0	Node number	0
---		Setting change	Permit
---		Writing during RUN	Permit
---		Operation setting	Independent
---		Communication protocol setting	MC protocol (form 4)

\*1 The setting is made by Mitsubishi's GPP function software.

■ MELSEC-QnA (CPU Direct Connection)

GP Setup		PLC Settings
Baud Rate	19200 bps	---
Data Length	8 bits	---
Stop Bit	1 bit	---
Parity Bit	Odd	---
Data Flow Control	ER Control	---
Communication Format <sup>*1</sup> (RS-232C)	RS-232C	---
Communication Format (RS-422)	4-wire type	---
Unit No.	0 (fixed)	---

*\*1 Only when using Digital's Programming Console I/F cable (GP430-IP10-O) for the MELSEC-A Series unit or a Diatrend Co. DAFXIH-CABV cable. Otherwise, a 4-wire type cable is required.*

■ MELSEC-Q Series (A Mode CPU Direct Connection)

GP Setup		PLC Settings
Baud Rate	9600bps (fixed)	——
Data Length	8bit (fixed)	——
Stop Bit	1bit (fixed)	——
Parity Bit	Odd (fixed)	——
Data Flow Control	ER Control	——
Communication Format	RS-232C	——
Unit No.	0 (fixed)	——

■ MELSEC-Q Series (Q Mode CPU Direct Connection)

GP Setup		PLC Settings <sup>*1</sup>	
Baud Rate	19200 bps	——	
Data Length	8bit (fixed)	——	
Stop Bit	1bit (fixed)	——	
Parity Bit	Odd (fixed)	——	
Data Flow Control	ER Control (fixed)	——	
Communication Format	RS-232C (fixed)	——	
Unit No.	0 (fixed)	——	
——		Use serial communication	Do not use

*\*1 Can be set for Q00CPU or Q01CPU only. The setting is made by Mitsubishi's GPP function software.*



**Range of data transfer speeds is from 9600bps to 15,200bps. However, the maximum speed available with GP70 Series units (except for GP-377 Series units) is 38,400bps.**

■ **MELSEC-Q Series (Q Mode CPU Direct Connection When Using Mitsubishi Electric Corporation MELSEC-QnA(LINK)Protocol<sup>\*1</sup>)**

GP Setup		PLC Settings <sup>*1</sup>	
Baud Rate	19200 bps	Transmission speed	19200bps
Data Length	8bit (fixed)		---
Stop Bit	1bit (fixed)		---
Parity Bit	Odd (fixed)		---
Data Flow Control	ER Control (fixed)		---
Communication Format	RS-232C (fixed)		---
		Run write setting	Enable
		Sum check	Yes
Unit No.	0 (fixed)		---
		Use serial communication	Use

*\*1 Can be set for Q00CPU or Q01CPU only. The setting is made by Mitsubishi's GPP function software.*

■ **MELSEC-Q Series (using A Mode CPU Computer Link Unit)**

GP Setup		Computer Link Unit Settings	
Baud Rate	19200bps (fixed)	Baud Rate	19200 bps
Data Length	7bits (fixed)	Data Bit	7 bits
Stop Bit	2bits (fixed)	Stop Bit	2 bits
Parity Bit	Even	Parity Check Parity setting even/odd	Yes Even
Data Flow Control	ER Control		---
Communication Format (RS-232C)	RS-232C	Mode Setup (RS-232C)	4 (Format 4 Protocol Mode)
Communication Format (RS-422)	4-wire type	Mode Setup (RS-422)	4 (Format 4 Protocol Mode)
	-	Write possible in RUN mode	Possible
	-	Sum Check	Yes
Unit No.	0 (fixed)	Station Number	0

■ **MELSEC-Q Series (Q Mode CPU Serial Communication Unit)**

GP Setup		Serial Communication Unit Settings <sup>*1</sup>	
Baud Rate	19200 bps	Baud Rate	19200 bps
Data Length	7 bits	Data Length	7 bits
Stop Bit	2 bits	Stop Bit	2 bits
Parity Bit	Even	Parity bit Even/Odd parity	Even
Control system	ER Control		---
Communication method (RS-232C is used.)	RS-232C		---
Communication method (RS-422 is used.)	4-wire type		---
	---	Thumb check code	Enabled
Unit No.	0	Node number	0
	---	Setting change	Permit
	---	Writing during RUN	Permit
	---	Operation setting	Independent
	---	Communication protocol setting	MC protocol (form 4)

*\*1 The setting is made by Mitsubishi's GPP function software.*

**2.1.5 2-Port Feature**

The 2-Port feature can be used in two ways:

- (1) Via the GP's built-in 2-Port feature
- (2) Via the external 2-Port Adapter II.

Both methods are described below:

**■ When Using GP unit's Internal 2-Port feature \*1**

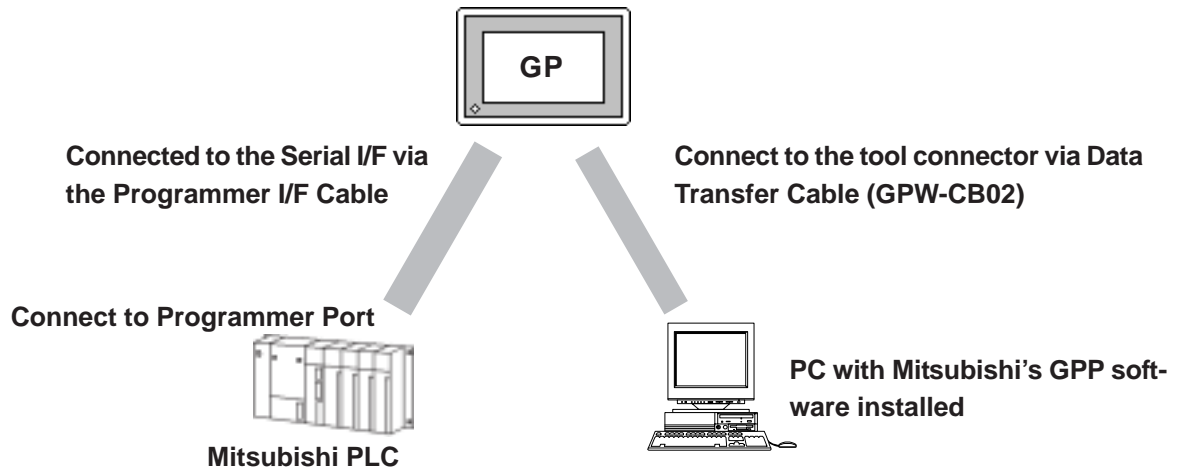

\*1 The Device Monitor feature can also be used at the same time.

For the ST series units, however, the Device Monitor feature cannot be used.

**◆ PLC models supporting Internal 2-Port Feature**

Series	CPU
MELSEC-AnA Series	A2A, A2U-S1, A2USH-S1, A3A, A2US
MELSEC-AnN Series	A1S, A1SH, A2N, A3H, A2SH, A3N, A0J2H
MELSEC-QnA Series	Q2A, Q2A-S1, Q2AS-S1, Q2ASH, Q4A
MELSEC-FX Series *1	FX0S, FX0N, FX1S, FX1N, FX2N, FX1NC, FX2NC, FX3UC
MELSEC-Q Series	Q02CPU-A, Q02HCPU-A, Q06HCPU-A, Q02CPU, Q02HCPU, Q06HCPU, Q12HCPU, Q25HCPU, Q00CPU, Q01CPU, Q00JCPU

\*1 MELSEC-FX Series' FX2 cannot use the internal 2-Port feature.

## ◆ GP models supporting the Internal 2-Port Feature

Series		GP Type	
GP-377 Series		GP-377L	
		GP-377S	
GP77 Series	GP-37W2 Series	GP-37W2B	
GP77R Series		GP-377R Series	GP-377RT
		GP-477R Series	GP-477RE
		GP-577R Series	GP-577RT
			GP-577RS
GP2000 Series		GP-2301H Series	GP-2301HL
			GP-2301HS
		GP-2401H Series	GP-2401HT
		GP-2300 Series	GP-2300L
			GP-2300T
		GP-2301 Series	GP-2301L
			GP-2301S
			GP-2301T
		GP-2400 Series	GP-2400T
		GP-2401 Series	GP-2401T
		GP-2500 Series	GP-2500T
		GP-2501 Series	GP-2501S
			GP-2501T
		GP-2600 Series	GP-2600T
GP-2601 Series	GP-2601T		
GLC2000 Series		GLC2300 Series	GLC2300L
			GLC2300T
		GLC2400 Series	GLC2400T
		GLC2500 Series	GLC2500T
		GLC2600 Series	GLC2600T
ST Series		ST400 Series	ST400
			ST401
			ST403



◆GPP Feature Software Package

MELSEC-A Series	DOS3.1.1 Series SW31VD-GPPA type GPP feature software package or later Windows95, Windows NT SW0D5*-GPPW type GPP feature software package or later
MELSEC-QnA Series	DOS 3.1.1 Series SW01VD-GPPQ type GPP feature software package Windows95, Windows NT SW0D5*-GPPW type GPP feature software package or later
MELSEC-FX Series	Windows 95 SW0PC-FXGP/WIN type GPP feature software package Windows 95, Windows NT SW4D5C-GPPW type GPP feature software package or later
MELSEC-Q Series	Windows 95, Windows NT SW4D5C-GPPW type GPP feature software package or later

■Internal 2-Port Feature Usage Notes



- The selections “USE ADAPTER MODE/CPU DIRECT MODE” will be displayed only when a direct CPU connection is used.
- The factory setting will become “Adapter”(when using 2-Port Adapter II).
- This feature can be used only while the GP is in ONLINE mode.
- Use Digital's transfer cable GPW-CB02.



- **If you transfer screen data while the GP is in ONLINE mode, the screen will not change to the data transfer screen automatically. Thus, you will need to change the screen manually to the OFFLINE mode's [Main Menu/ Transfer] screen. When sending screen data, be sure to pause or quit any GPP feature ladder monitoring or device monitoring.**
- **Since the internal 2-Port feature uses the GP's single tool connector, you will not be able to use optional equipment which requires the tool connector (i.e. a Barcode Reader, etc.)**
- **Peripheral equipment which cannot be connected to the GP's tool connector (such as a Programming Console) is not compatible with the GP's Internal 2-Port feature. To use this type of equipment, you will need to use the external 2- Port Adapter II.**
- **When using the GP's built-in 2-Port feature, be sure not to switch to OFFLINE mode while the GPP software is communicating with the PLC. Switching to OFFLINE mode will result in a communication (data transfer) break**
- **With GP2000, GP77R and ST series units, if the 2-Port feature is designated, the Simulation feature cannot be used. Be sure to select "Adapter" or "Direct" when using the Simulation feature.**
- **When using the GP's built-in 2-Port feature with the MELSEC-Q Series, be sure to set your PC's data link speed to the same values as used by the GP. If the setting values are different, an error will appear on the GP and your PC. The error will appear as shown below.**

<GP>

"PC's data link speed is different. (02:F5)"

<PC>

"Cannot communicate with the PC."

<e.g : GP-377 series unit's screen>

- ① Touch item, PLC SETTING.  
The SET UP OPERATION SURROUNDINGS menu will appear.

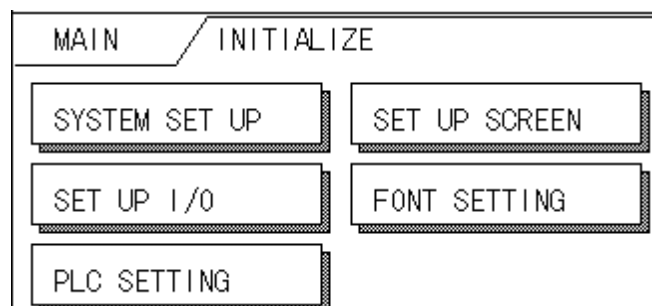

- ② Touch the button, SET on the upper right on the screen. The SET UP OPERATION SURROUNDINGS 2 menu appears.

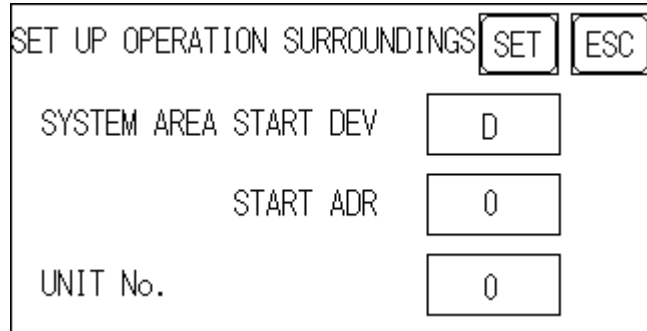

- ③ Touch the “2-Port Feature/ CPU Direct” selection’s right side setting box until “IN-SIDE” appears. When using the 2-Port Adapter II unit, select “Adapter”, or “CPU” for a direct CPU connection. When using the 2-Port Adapter with GP2000H or ST Series units (Excluding Mitsubishi's MELSEC-FX (CPU2) Protocol), select "Adapter + GPH".

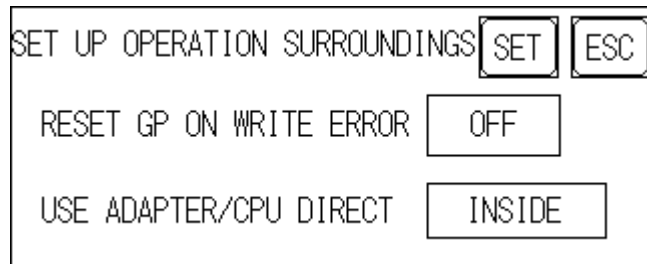

**■ When Using the External 2-Port Adapter Cable \*1**

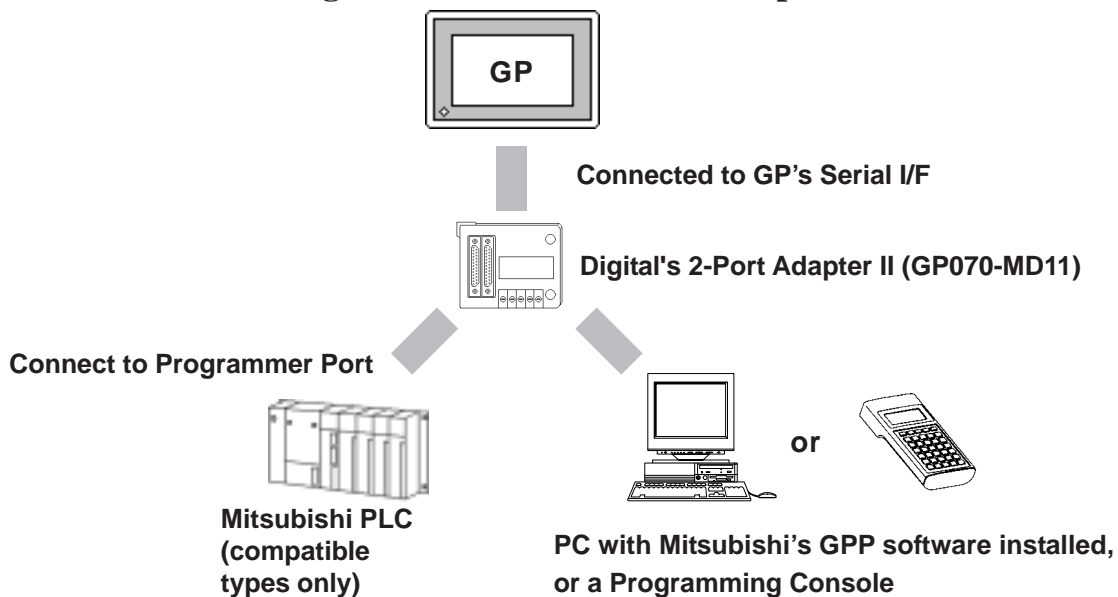

\*1 2-Port Adapter can be used for the GP series units supporting the internal 2-Port feature .

**■ PLCs supported by the 2-Port Adapter II**



For information about which CPUs the 2-Port Adapter II (GP070-MD11) can connect to, refer to the 2-Port Adapter II Users Manual.

## ■ When Using the 2-Port Adapter II

Set up from the GP's OFFLINE mode when using 2-Port Adapter II.

**Reference** *GP User Manual (Sold separately), "OFFLINE Mode"*

### ◆ GP70 Series (except GP-377 series)



- The selections "USE ADAPTER MODE/CPU DIRECT MODE" will be displayed only when a direct CPU connection is used.
- The factory setting will become "2 Port".

<e.g : GP-570 series unit's screen>

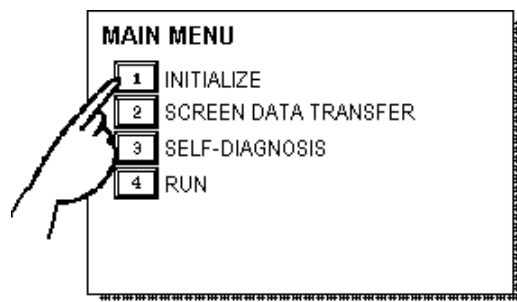

- ① Touch item #1, INITIALIZE. The INITIALIZE menu will appear.

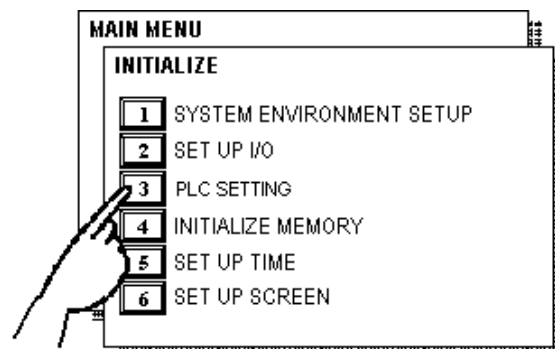

- ② Touch item #3, PLC SETTING. The PLC SETTING menu appears.

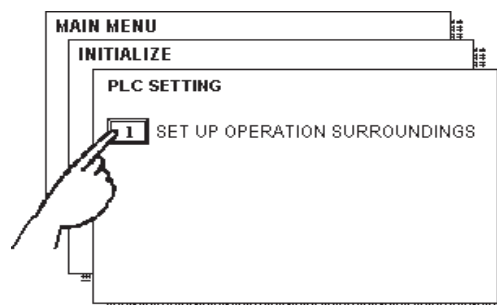

- ③ Touch item #1, SET UP OPERATION SURROUNDINGS. The SET UP OPERATION SURROUNDINGS menu will appear.

SET UP OPERATION SURROUNDINGS	[ ]
STARTING ADDRESS OF SYSTEM DATA AREA	[ ]
UNIT NO.	[ ]
SYSTEM AREA    READING AREA SIZE (0-256)	[ ]
RESET GP ON DATA WRITE ERROR	ON    OFF
USE ADAPTER MODE/CPU DIRECT MODE	<input checked="" type="radio"/> 2PORT    2PORT+GPH    CPU

- ④ Touch the “USE ADAPTER MODE/CPU DIRECT MODE” selection. The selected item is highlighted.

**GP70 Series Units**

- ⑤ When using the 2 port adapter II (GP070-MD11), select the *2PORT* option. For *GPH70* however, select *2PORT + GPH*. Select CPU when connecting CPU directly.

◆ GP-377/GP77R/GP2000/ST Series



- The selections “2 Port Mode/CPU DIRECT MODE” will be displayed only when a direct CPU connection is used.
- The factory setting will become “Adapter”.

<e.g : GP-577R series unit's screen>

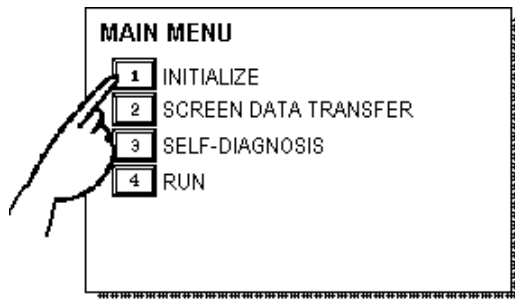

- ① Touch item #1, INITIALIZE. The INITIALIZE menu will appear.

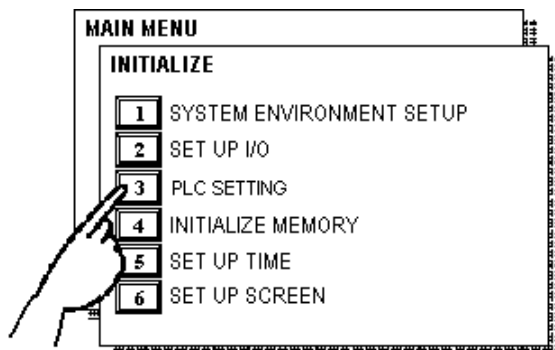

- ② Touch item #3, PLC SETTING. The PLC SETTING menu appears.

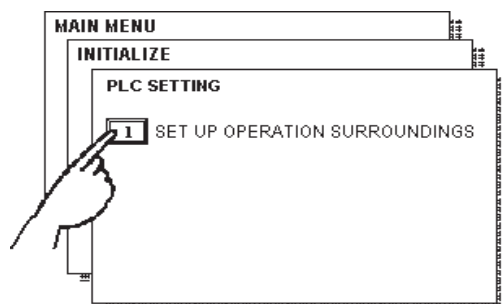

- ③ Touch item #1, SET UP OPERATION SURROUNDINGS. The SET UP OPERATION SURROUNDINGS menu will appear.

SET UP OPERATION SURROUNDINGS	
STARTING ADDRESS OF SYSTEM DATA AREA	[       ]
UNIT NO.	[   ]
SYSTEM AREA    READING AREA SIZE (0-256)	[   ]
RESET GP ON DATA WRITE ERROR	ON      OFF
<input checked="" type="checkbox"/> USE ADAPTER MODE/CPU DIRECT MODE	<input checked="" type="checkbox"/> ADAPTER    ADAPTER + GPH    CPU    INSIDE

- ④ Touch the “USE ADAPTER MODE/CPU DIRECT MODE” selection. The selected item is highlighted.

**GP77R Series Units**

- ⑤ When using the 2 Port Adapter II (GP070-MD11), select the *ADAPTER* option. When using GP2000H or ST Series units with the 2-Port Adapter (Excluding Mitsubishi's MELSEC-FX (CPU2) Protocol), select "Adapter + GPH". Select *CPU* when connecting CPU directly. When using the internal 2-Port feature, select *INSIDE* option.