

# Device/PLC Connection Manuals

---



## About the Device/PLC Connection Manuals



Prior to reading these manuals and setting up your device, be sure to read the "Important: Prior to reading the Device/PLC Connection manual" information. Also, be sure to download the "Preface for Trademark Rights, List of Units Supported, How to Read Manuals and Documentation Conventions" PDF file. Furthermore, be sure to keep all manual-related data in a safe, easy-to-find location.

# GE Fanuc Automation Ethernet

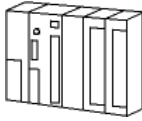

## 1 System Structure

The following describes the system structure used when connecting the GP/GLC to the GE Fanuc PLC.

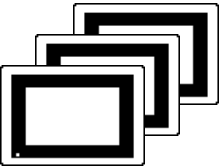
### ■ Series 90-30

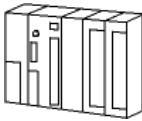

CPU	Link I/F	Cable	Supported Models <sup>*1</sup>
	Ethernet unit 		
CPU311, CPU313 CPU323, CPU331 CPU340, CPU341 CPU350, CPU351 CPU352, CPU360 CPU363, CSE311 CSE313, CSE323 CSE331, CSE340	IC693CMM321	Ethernet Cable IEEE802.3 standard	GP/GLC Series Factory Gateway
CPU364, CPU374	Ethernet I/F on CPU unit		

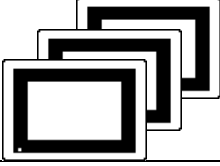
### ■ Series 90-70

CPU	Link I/F	Cable	Supported Modles <sup>*1</sup>
	Ethernet Unit 		
CPU731, CPU771, CPU772, CPU780, CPU781, CPU782, CPU788, CPU789, CPM915, CPM925, CPM790, CSE784, CSE924, CSE925, CPX772, CPX782, CPX928, CPX935, CGR772, CGR935	IC697CMM742	Ethernet Cable IEEE802.3 Standard	GP/GLC Series Factory Gateway

*\*1 When using GP/GLC and the optional Ethernet I/F unit, refer to the following List of Connectable GP/GLC Units.*

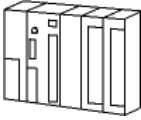
■ **RX7i**

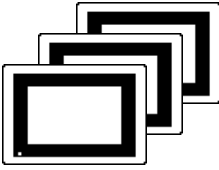
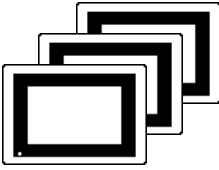
CPU	Link I/F	Cable	Supported Models <sup>*1</sup>
			
CPE010 CPE020 CRE020	Ethernet I/F on CPU unit	Ethernet Cable IEEE802.3 Standard	GP/GLC Series Factory Gateway

*\*1 When using GP/GLC and the optional Ethernet I/F unit, refer to the following List of Connectable GP/GLC Units.*

◆ **Compatible GP/GLC Types**

Series		Product Name	Optional Ethernet Unit	Built-in Ethernet Port	
GP77R Series	GP-377R Series	GP-377RT	○ <sup>*1*2</sup>	X	
	GP-477R Series	GP-477RE	○ <sup>*2</sup>	X	
	GP-577R Series	GP-577RS	○ <sup>*2</sup>	X	
		GP-577RT	○ <sup>*2</sup>	X	
GP2000 Series	GP-2300 Series	GP-2300L	X	○	
		GP-2300T	X	○	
	GP-2400 Series	GP-2400T	X	○	
		GP-2500 Series	GP-2500L	○ <sup>*3*4</sup>	○
			GP-2500S	○ <sup>*3*4</sup>	○
	GP-2500T	○ <sup>*3*4</sup>	○		
	GP-2501 Series	GP-2501S	○ <sup>*2*3</sup>	X	
		GP-2501T	○ <sup>*2*3</sup>	X	
	GP-2600 Series	GP-2600T	○ <sup>*3*4</sup>	○	
	GP-2601 Series	GP-2601T	○ <sup>*2*3</sup>	X	
GLC2000 Series	GLC2300 Series	GLC2300L	X	○	
		GLC2300T	X	○	
	GLC2400 Series	GLC2400T	X	○	
	GLC2600 Series	GLC2600T	○ <sup>*3*4</sup>	○	
Factory Gateway		—	X	○	
ST Series		ST403	X	○	

*\*1 Only Multi unit can be used.*

*\*2 The 2-Way Driver (Pro-Server, GP-Web and others) cannot be used.*

*\*3 When using optional Ethernet I/F unit, a bus conversion unit (PSL-CONV00) is required.*

*\*4 Using the optional Ethernet I/F unit allows you to set up separate Class and Net No.s for 2-Way Driver applications (Pro-Server, GP-Web and others) and the PLC. When doing this, data transfer with the PLC is performed through the optional Ethernet I/F Unit.*



- For cable connection and Optional Unit information, refer to the User Manual for each optional unit. For GP2000 and GLC2000 series units, refer to that unit's User Manual.

◆ Connection Structure

<1 : 1 connection>

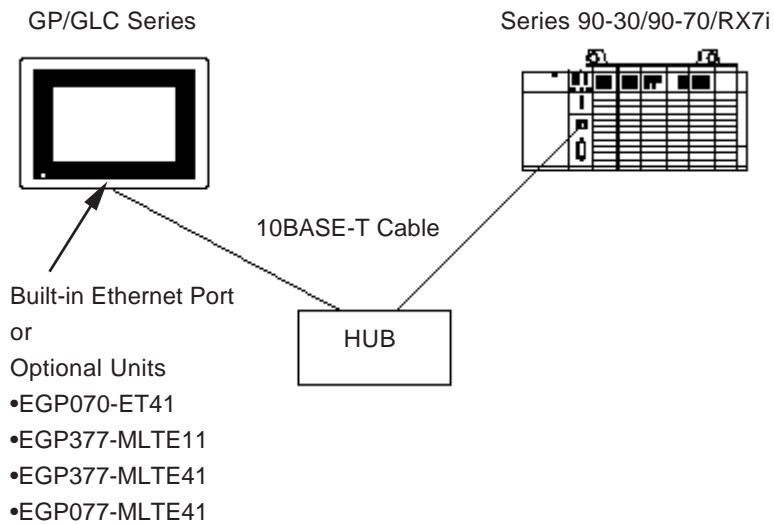

<n : 1 connection>

Series 90-30 : Up to 32 units per a PLC unit  
Series 90-70/RX7i : Up to 16 units per a PLC unit

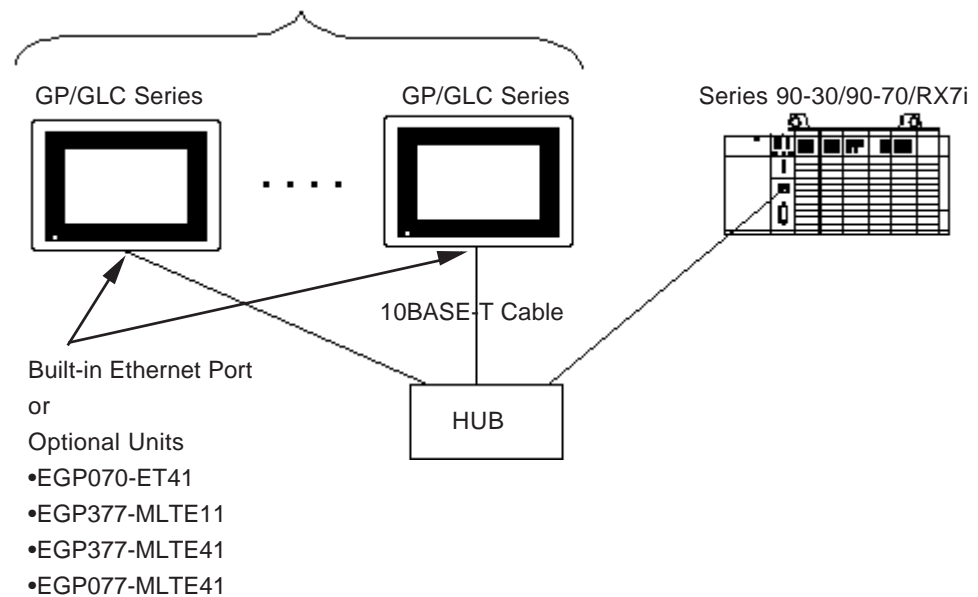

- **When connecting plural units of Series 90-30, CPU with V6.50 and more is required.**

**The version of CPU can be checked from the [Status Info] menu of ladder software.**

\*1 In RX7i, 2 Ethernet I/Fs have been installed and any of them can be connected.

## 2 Supported Devices

The following list shows the range of devices supported by the GP/GLC.

### ■ Series 90-30/90-70/RX7i

Setup System Area here.

Device	Bit Address	Word Address	Particulars	
Input Relay (I)	I0001 ~ I32768	I00001 ~ I32753	<span style="border: 1px solid black; padding: 2px;">÷16+1</span>	L/H
Output Relay (Q)	Q00001 ~ Q32768	Q0001 ~ Q32753	<span style="border: 1px solid black; padding: 2px;">÷16+1</span>	
Internal Relay (M)	M00001 ~ M32768	M0001 ~ M32753	<span style="border: 1px solid black; padding: 2px;">÷16+1</span>	
Global Relay (G)	G0001 ~ G7680	G0001 ~ G7665	<span style="border: 1px solid black; padding: 2px;">÷16+1</span>	
Momentary Relay (T)	T0001 ~ T1024	T0001 ~ T1009	<span style="border: 1px solid black; padding: 2px;">÷16+1</span>	
System Function Relay (SA)	SA001 ~ SA128	SA001 ~ SA113	<span style="border: 1px solid black; padding: 2px;">÷16+1</span>	
System Function Relay (SB)	SB001 ~ SB128	SB001 ~ SB113	<span style="border: 1px solid black; padding: 2px;">÷16+1</span>	
System Function Relay (SC)	SC001 ~ SC128	SC001 ~ SC113	<span style="border: 1px solid black; padding: 2px;">÷16+1</span>	
System Function Relay (S)	S001 ~ S128	S001 ~ S113	<span style="border: 1px solid black; padding: 2px;">÷16+1</span> *1	
Register (R)	---	R00001 ~ R32640	<span style="border: 1px solid black; padding: 2px;">Bit 5</span>	
Analog Input (AI)	---	AI0001 ~ AI32640	<span style="border: 1px solid black; padding: 2px;">Bit 5</span>	
Analog Output (AQ)	---	AQ0001 ~ AQ32640	<span style="border: 1px solid black; padding: 2px;">Bit 5</span>	

(Continued on following page.)

\*1 Data cannot be written to this relay. If data is written, a host communication error (02:02:05) will be displayed.



**Depending on the CPU used, the devices address ranges may differ.**

■ Series 90-30/90-70/RX7i (Continued from previous page)

Device	Bit Address	Word Address	Particulars	
Word (W)	---	W0000001 ~ W0065536	Bit 5	*2 L/H
		W0065537 ~ W0131072		
		W0131073 ~ W0196608		
		W0196609 ~ W0262144		
		W0262145 ~ W0327680		
		W0327681 ~ W0393216		
		W0393217 ~ W0458752		
		W0458753 ~ W0524288		
		W0524289 ~ W0589824		
		W0589825 ~ W0655360		
		W0655361 ~ W0720896		
		W0720897 ~ W0786432		
		W0786433 ~ W0851968		
		W0851969 ~ W0917504		
		W0917505 ~ W0983040		
		W0983041 ~ W1048576		
		W1048577 ~ W1114112		
		W1114113 ~ W1179648		
		W1179649 ~ W1245184		
		W1245185 ~ W1310720		
		W1310721 ~ W1376256		
		W1376257 ~ W1441792		
		W1441793 ~ W1507328		
		W1507329 ~ W1572864		
		W1572865 ~ W1638400		
		W1638401 ~ W1703936		
		W1703937 ~ W1769472		
		W1769473 ~ W1835008		
		W1835009 ~ W1900544		
		W1900545 ~ W1966080		
W1966081 ~ W2031616				
W2031617 ~ W2048000				

\*2 Word (W) are each 65536 words on your GP application.

Therefore, you cannot extend over more than a single data block when performing some features.

For example, when using the following features, be sure to set these features' settings so they are within a single data block.

- 1) "a-tag" settings
- 2) Block Write/Read from Pro-Server
- 3) Designating the "Convert from Before" and "Convert to After" addresses for "Address Conversion" features.
- 4) PLC Device Read/Write using D-Script's Memory Operation Feature
- 5) Write from SRAM to PLC Device using Filing Data Feature



• **Depending on the CPU used, the devices address ranges may differ.**

• **Word (W) can be used for RX7i only.**

### 3 Environment Setup

#### ■ GP Settings

The GP's Ethernet communication settings are as follows.

#### ◆ SET UP OPERATION SURROUNDINGS Menu

SETUP OPERATION SURROUNDINGS MENU

RETURN

1 SETUP OPERATION SURROUNDINGS

2 SETUP ETHERNET INFORMATION

3 SETUP ETHERNET EXT. INFORMATION

#### ◆ SET UP ETHERNET INFORMATION

Select "SETUP ETHERNET INFORMATION," and then enter the necessary information for each item.

SETUP ETHERNET INFORMATION

SET CANCEL

SRC IP ADDRESS [ ] . [ ] . [ ] . [ ]

SRC PORT NO. [ ]

DEST IP ADDRESS [ ] . [ ] . [ ] . [ ]

DEST PORT NO. [ ]

1 2 3 4 5 6 7 8 9 0 ↑ ↓ BS

← →

- **SRC IP ADDRESS**

Enter the IP address for the GP at your station. To do this, separate the 32 bits of the IP address into four segments of eight bits each, delimit those segments with a dot, and then enter them as decimal numbers.

- **SRC PORT NO.**

Enter your station port number in the range from 1024 to 65535.

- **DEST IP ADDRESS**

Enter the PLC IP address.

- **DEST PORT NO.**

Enter the PLC port number. Set the PLC port number to 18245.



For the IP addresses, check with the network manager. Do not specify any duplicate IP addresses.



**When using the built-in Ethernet port on a GP2000 or GLC2000 series unit, be sure not to set any duplicate "SRC PORT No." values.**

**Check the 2-Way driver's "SRC PORT No." setting via the following menu:**

**GP OFFLINE mode's Main menu [INITIALIZE] -> [SETUP OPERATION SURROUNDINGS] -> [EXTENDED SETTINGS] -> [SETUP ETHERNET INFORMATION].**

**The default value is 8000. The 2-Way driver uses this port and the following 9 ports (8000 ~ 8009).**

◆ **SET UP NETWORK EXT. INFORMATION**

SETUP NETWORK EXT. INFORMATION												SET	CANCEL
SEND WAIT TIME	[	]	(ms)										
TIMEOUT	[	]	(x 2sec)										
IP ROUTER ADDRESS	[	]	.	[	]	.	[	]	.	[	]		
SUBNET MASK	[	]	.	[	]	.	[	]	.	[	]		
	1	2	3	4	5	6	7	8	9	0	↑	↓	BS
	←	→											

- **SEND WAIT TIME (0 to 255)**

Wait time can be added when a command is transmitted from the GP. Use the wait time if the traffic on the communications line is heavy. If no wait time is required, enter "0."

- **TIMEOUT (0 to 65535)**

Enter the desired timeout value. If no response is received from the other station within the specified time, a timeout occurs. If "0" is specified, the default time is 15 seconds.

- **IP ROUTER ADDRESS**

Enter the IP address of the router (only one). If no router is used, enter "0" in all fields.



- **SUBNET MASK**

Enter subnet masks. If no subnet mask is used, enter “0” in all fields.



***If the memory is initialized in the OFFLINE mode, random values may be included. Be sure to check the displayed values.***

## ■ PLC Settings

The communications settings for the GP/GLC, which are required for communications via the Ethernet, as shown below:

### ◆ Series 90-30/90-70/RX7i

GP/GLC Setting		PLC Setting	
SRC IP Address	GP IP Address <sup>*1</sup>	_____	_____
SRC Port No.	GP Port Number <sup>*2</sup>	_____	_____
Target IP Address	PLC IP Address <sup>*1</sup>	IP Address	PLC IP Address
Target Port No.	PLC Port Number <sup>*3</sup>	_____	_____

*\*1 Contact your network administrator about setting values. When the SRC IP Address is 0.0.0.0, the IP address set in the 2-Way driver is effective.*

*\*2 When using the following function on a GP2000 Series unit, be sure not to use duplicate port number values. Check the 2-Way driver's port number setting via the following menu:*

*From the GP OFFLINE mode's Main menu [INITIALIZE] -> [SETUP OPERATION SURROUNDINGS] -> [EXTENDED SETTINGS] -> [SETUP ETHERNET INFORMATION].*

*The default value is 8000. The 2-Way driver uses this port and the following nine ports for a total of 10 (8000 ~ 8009).*

*\*3 Set the PLC Port Number to 18245.*



• **Protocol Type is TCP/IP Connection.**

**4 Error Codes**

**Reference** About the GP Ethernet Specific Error Codes, refer to Device/PLC Connection Manual’s “Protocol Stack Error Codes”.

**PLC SPECIFIC ERROR CODES**

The PLC error codes are displayed by the “Host Communication Error (02:\*\*:##)”, and are indicated in the left lower corner of the GP screen.

Error codes are displayed using 2-byte codes; Major Error Status Code and Minor Error Status Code.

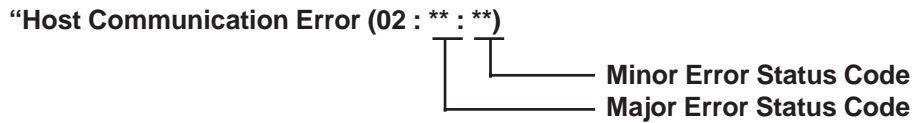

**Series 90-30/90-70**

Major Error Status Code	Minor Error Status Code	Reason
02	05	Data is written in System Function Relay (S).
05	F4	Designated device is out side allowable range.

**RX7i**

Major Error Status Code	Minor Error Status Code	Reason
05	E9	Data is written in System Function Relay (S).
05	90	Designated device is out side allowable range.

## 7.9 Protocol Stack Error Codes

Protocol Stack Error Codes are displayed on the GP as follows.

Host communication error (02:FE:\*\*)

\*\* represents one of the following error codes, from 00 to F0.

Error Code	Description	Notes
00	There is a setup error related to the IP address of your station at initialization.	
05	Initialization has failed.	
06	Cancelling of communications has failed.	
07	An attempt was made to establish a connection before initialization was successfully completed.	
08	Your station's port number is incorrect	
09	The destination station's port number is incorrect.	
0A	The IP address of the other station is incorrect.	
0B	The same port number is already being used by UDP for establishing the connection.	
0C	The same port number is already being used by TCP for establishing the connection.	
0D	Protocol stack has refused connection establishment.	
0E	Protocol stack has returned the unsuccessful establishment of a connection.	
0F	The connection has been shut down.	
10	All connections are busy. No connection is available.	
13	Your station was aborted by a different station.	
30	There was no reply from the protocol stack.	
32	There was no reply from the other station.	*1*2
40	No network information exists for the designated node.	*1
41	I/O memory type of the random read-out response data is incorrect.	*1
42	Network information does not exist.	
F0	Undefined error.	

\*1 When using an OMRON Corporation CS1/CJ/CJ1M Series unit, the error code will appear on the GP screen as shown below. Also, behind the Ethernet error code will appear the designated Network and Node addresses.

Host Communication Error (02:FE:\*\*:###:###)

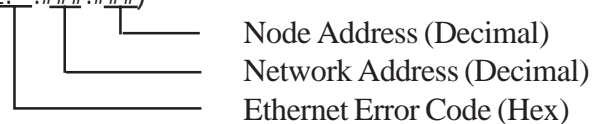

\*2 When using a Hitachi Industrial Equipment Corporation's HIDIC H Series or a Schneider Corporation MODBUS TCP unit, the error code will appear on the GP screen as shown below. Also, behind the Ethernet error code will appear the designated Node address.

Host Communication Error (02:FE:\*\*:###:###)

