



DANGERS

When Designing your LogiTouch System:

- Be sure to design your LogiTouch control system so that in the event of a main power supply failure or a LogiTouch accident, this system's overall safety integrity will be maintained. If this is not done, incorrect output signals or a LogiTouch malfunction may cause an accident.
 - (1) Interlock circuits, etc. designed to interrupt or oppose normal machine movement (i.e. Emergency Stop, General Protection, forward and reverse rotation, etc.), as well as those designed to prevent machine damage (i.e. for upper, lower and traverse movement limit positioning, etc.) should all be designed to be located outside of the LogiTouch.
 - (2) Whenever the LogiTouch generates a "Watchdog Timer Error", LogiTouch operation will halt. Also, when an error occurs in Input/Output control areas that the LogiTouch cannot detect, it is possible for unexpected equipment operation to occur there. As a result, to prevent unsafe or unexpected equipment operation, a "Failsafe Circuit" should be created which is completely external to the LogiTouch.
 - (3) If an external unit's relay or transistor malfunctions, causing an output (coil) to remain either ON or OFF, a major accident can occur. To prevent this, be sure to set up external watchdog circuits that will monitor vital output signals.
- Be sure to design a circuit that will supply power to the LogiTouch's I/O unit(s) before starting up the LogiTouch. If the LogiTouch's internal program enters RUN mode prior to the I/O unit's load control power turning ON, an incorrect output (signal) or malfunction could cause an accident to occur.
- Be sure to design a program that will ensure the safety of your system in, in the event of a LogiTouch display or control unit malfunction, or in the event of either a data transmission error or power failure between the LogiTouch and any connected unit(s). These types of problems can lead to an incorrect output (signal) or malfunction, which could thereby cause an accident to occur.
- Do not create touch panel switches which could possibly endanger the safety of humans or equipment. This is due to the possibility of a malfunction in the LogiTouch or its cable(s), causing the output of a signal that could result in a major accident. All of a system's major, safety-related switches should be designated to be operated separately from the LogiTouch.
- Be sure to design your system so that equipment will not malfunction due to a communication fault between the LogiTouch and its host controller. This is to prevent any possibility of bodily injury or material damage.
- Do not use the LogiTouch with aircraft control devices or medical life support equipment, central trunk data transmission (communication) devices, nuclear power control devices, or medical life support equipment, due to these devices inherent requirements of extremely high levels of safety and reliability.
- When using the LogiTouch with transportation vehicles (trains, cars and ships), disaster and crime prevention devices, various types of safety equipment, non-life support related medical devices, etc. be sure to use redundant and/or failsafe system designs ensure the proper degree of reliability and safety.



WARNINGS

- After the LogiTouch's backlight burns out, unlike the LogiTouch's "Standby Mode", the touch panel is still active. If the operator fails to notice that the backlight is burned out and touches the panel, a potentially dangerous machine operation error can occur.

1) If your LogiTouch is not set to "Standby Mode" and the screen has gone blank, your backlight is burned out.

2) Or, if your LogiTouch is set to Standby Mode, but touching the screen does not cause the display to reappear, your backlight is burned out.

Also, to prevent an accidental machine operation error, Pro-face suggests you use the LogiTouch's built-in "USE TOUCH PANEL AFTER BACKLIGHT BURN-OUT" feature, that will automatically detect a burnout and disable the touch screen.

Installation:

- High voltage runs through the LogiTouch. Except for replacing the backlight, never disassemble the LogiTouch, otherwise an electric shock can occur.
- Do not modify the LogiTouch unit. Doing so may cause a fire or an electric shock.
- Do not use the LogiTouch in an environment where flammable gasses are present, since operating the LogiTouch may cause an explosion.

Wiring:

- To prevent electric shock or equipment damage, prior to installing or wiring the LogiTouch, be sure that the LogiTouch's power cord is unplugged from the power supply.
- Be sure to reattach the LogiTouch terminal block's plastic cover after completing any terminal wiring. If this cover is not reattached, an electric shock could easily occur.
- High voltage runs through the LogiTouch. Except for changing the backlight, do NOT attempt to open the LogiTouch, since there is a possibility of an electric shock.
- Do not use power levels with the LogiTouch that are outside of the LogiTouch's specified power range. Doing so may cause a fire, electric shock or damage the LogiTouch.

Operation and Maintenance:

- Do not touch a live power terminal. This could cause a shock or machine malfunction.
- Due to the danger of an electric shock, be sure to confirm that the LogiTouch's power cord is unplugged before either cleaning the LogiTouch or attaching/detaching the power terminal block screws.
- When replacing the LogiTouch's backlight, be sure to unplug the unit's power cord to prevent a shock, and wear gloves to prevent being burned.
- The LogiTouch uses a lithium battery for backing up its internal clock and control memory data. If the battery is incorrectly replaced (i.e. the + and - sides are reversed), the battery may explode. Therefore, before changing the battery, Pro-face recommends that you contact your local LogiTouch distributor for battery replacement instructions.
- Do not modify the LogiTouch's internal parts or wiring, since doing so may lead to either a shock or fire.



CAUTIONS

Wiring Layout:

- Be sure that all LogiTouch input/output signal lines are isolated from all power wiring or power cables, via a separate wiring duct. This is to prevent excessive noise, which can cause a unit malfunction.

Installation:

- Be sure all data cables attached to the LogiTouch are securely connected. If all connector pins do not make complete contact, incorrect input or output signals can result.

General Wiring:

- To prevent shocks or malfunctions, LogiTouch's FG (earth) wire should be grounded according to the following:
 - 1) Be sure to use a maximum grounding resistance of 100Ω or less.
 - 2) A grounding wire of 2mm² or larger should be used.
- Be sure to confirm that the LogiTouch's operating voltage and wiring terminal locations are correct. If either are incorrect, it can cause a fire or accident.
- Be sure to secure all wiring terminal screws in place with the designated torque. Screws and terminals that become loose can cause a short circuit, fire or accident.
- Be sure that metal filings or wiring remnants do not fall inside the LogiTouch, since they can cause a fire, accident, or malfunction.

LogiTouch Operation and Maintenance:

- Be sure to read the LogiTouch's manual and on-line help information carefully before performing program changes, forced output, or utilizing the RUN, STOP or PAUSE commands while the LogiTouch is in operation. Mistakes concerning the use of these items can cause an accident or equipment or damage.
- The LogiTouch's liquid crystal display contains a powerful irritant and if for any reason the panel is damaged and this liquid enters your eye, flush your eye for 15 minutes with running water and contact a physician.

LogiTouch Unit Disposal:

- Be sure to dispose of the LogiTouch unit in a manner appropriate to your country's industrial machinery disposal standards.

UL/c-UL(CSA) Application Notes

The GLC150-BG41-XY32SC-24V is a UL/c-UL listed product.
(UL file No. E214883)

This unit conforms as a component to the following standards:

■UL508

Industrial Control Equipment

■UL1604

Electrical Equipment for Use in Class I and II Division 2 and Class III Hazardous (Classified) Locations

■CAN/CSA-C22.2, Nos.1010

Standard for Safety of Information Technology Equipment, including Electrical Business Equipment

GLC150-BG41-XY32SC-24V (UL Registration Model : 2980036-04)

<Cautions>

If the LogiTouch is installed so as to cool itself naturally, be sure to install it in a vertical panel. Also, be sure that the LogiTouch is mounted at least 100mm away from adjacent structures and other equipment, otherwise, the heat generated by the LogiTouch's internal components may become higher than that allowed by UL standard requirements. The LogiTouch shall be separated from the mains by double or reinforced insulation.

UL1604 Conditions of Acceptability and Handling Cautions:

1. Power, input and output (I/O) wiring must all be in accordance with Class I, Division 2 wiring methods, Article 501-4 (b) of the National Electrical Code, NFPA 70, or as specified in Section 18-152 of the Canadian Electrical Code for units installed within Canada, and in accordance with that location's authority.
2. Suitable for use in Class I, Division 2, Groups A, B, C and D hazardous locations, or nonhazardous locations only.
3. WARNING: Explosion hazard - substitution of components may impair suitability for Class I, Division 2.
4. WARNING: Explosion hazard - do not disconnect equipment unless power has been switched OFF or the area is known to be nonhazardous.
5. WARNING: Explosion hazard - when in hazardous locations, turn OFF power before replacing or wiring modules.

CE Marking Notes

The GLC150-BG41-XY32SC-24V is a CE marked, EMC compliant product. This unit also conforms to EN55011 Class A, EN50082-2 directives.

For detailed CE marking information, please contact your local LogiTouch distributor.

CNS Notes

The GLC150-BG41-XY32SC-24V conforms as a component to the following standards:

- CNS 13438 (Class A)

<Cautions>

The LogiTouch unit is designated as Class A industrial equipment. Therefore, when using this unit in a residential area, be careful to avoid electromagnetic interference from nearby home appliances.

<警告使用者>

這是甲類的資訊產品、在居住的環境中使用時、可能會造成射頻干擾、在這種情況下、使用者會被要求採取某些適當的對策。

Package Contents

The following items are included in the LogiTouch's package. Before using the LogiTouch, please confirm that all items shown here are present.

- LogiTouch Type-A2 (1)
(GLC150-BG41-XY32SC-24V)

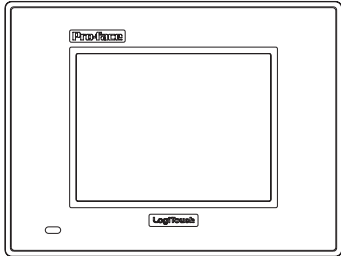

- Installation Guide (1)
<This Guide>

- Installation Fasteners (4)

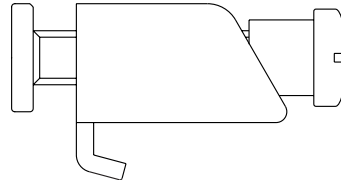

This unit has been carefully packed, with special attention to quality. However, should you find any of the items shown here to be damaged or missing, please contact your local LogiTouch distributor immediately.

Option Items (sold separately)

- LogiTouch Series User Manual
(GLC150-MM01)

- DIO Connector

- Logic Program Development Software
LogiTouch Editor

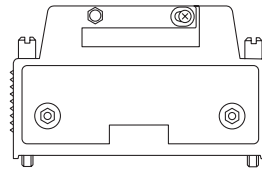

- Data Transfer Cable (GPW-CB02)

Fujitsu Takamisawa	FCN-361J040-AU (connector)
Component Co. Inc.	FCN-360C040-B (cover)

Option

Digital Elec. Corp.	GLC100-DIOCN01 (connector / cover) 5 pieces
---------------------	--

1 Part Names

The LogiTouch Type-A2's part names and their functions are explained below.

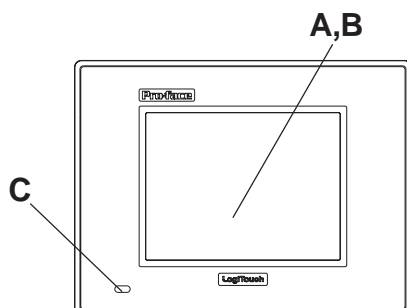

- A : Display :
Displays controller and user-created screen data.
- B : Touch Panel :
Performs touch-initiated screen change operations.

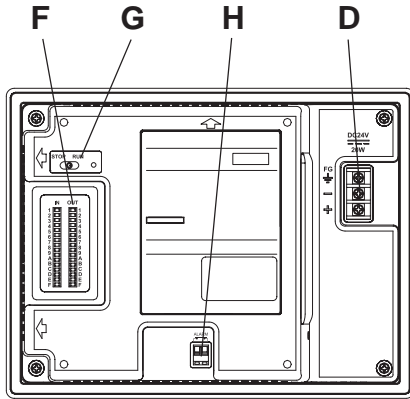

C : Status LED :

Operation Mode ^{*1}	Controller Operation Mode ^{*2}	LED Color
OFFLINE	—	Green - Constant
In Operation	RUN	Green - Constant
In Operation	STOP	Green - Flashing
In Operation	Backlight burnout has occurred	Green / Red - Constant
In Operation	Major Error	Red - Constant

*1 Operation mode includes Display, and touch key features.

*2 Includes the performance of logic circuit program features.

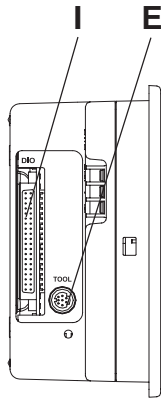

D : Power Input Terminal Block :

The input and ground terminals for the DC power cable.

E : Tool Connector :

Data Transfer cable is connected here.

F : Input/Output LED :

Indicates the input/output of DIN/DOU signal.

G : RUN/STOP Switch (LED lights during RUN mode.) :

RUN - Indicates the logic program is operating.

STOP - Indicates the logic program has stopped.

H : Alarm Output :

Turns OFF (Releases) the designated contact when a major or watchdog error occurs.

Reference Alarm Output Circuit

I : Input/Output Connector

2

General Specifications

Rated Voltage	DC24V
Voltage Supply Range	DC20.4 to DC28.8V
Ambient Operating Temperature	0 to 50
Ambient Humidity	20%RH to 85%RH (no condensation)
Atmospheric Pressure	800hPa to 1114hPa (2000 meter or lower)
Atmosphere	Pollution Degree 2

3

Dimensions

The GLC150-BG41-XY32SC-24V unit dimensions are as follows.

(Unit:mm [in.] - Excluding projections)

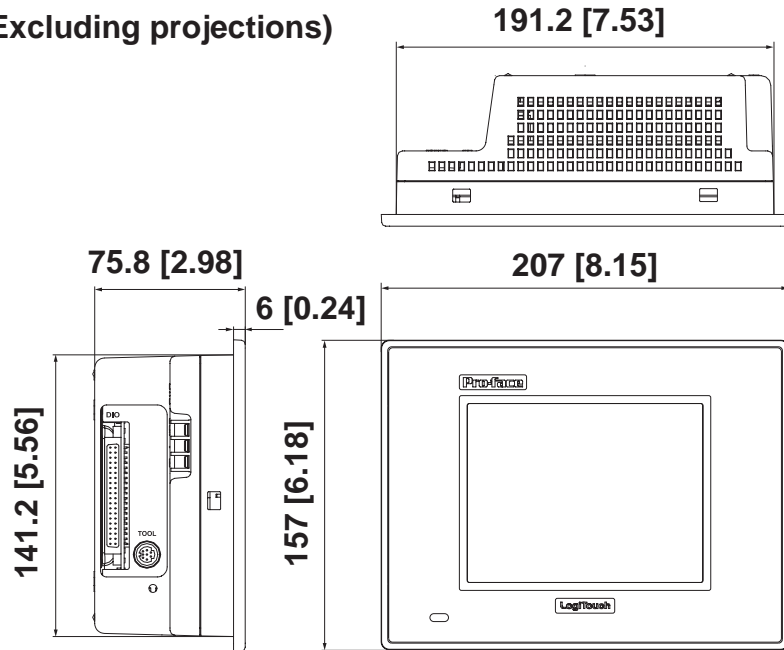

4

Interfaces

Input/Output Interface

The following table shows the pin assignments for this connector.

Pin Arrangement	Pin No.	Signal	Pin No.	Signal
	A1	COM (24V : DOUT)	B1	COM (0V:DIN)
	A2	COM (24V : DOUT)	B2	0V (DOUT)
	A3	NC	B3	NC
	A4	NC	B4	NC
	A5	DOUT 15	B5	DIN 15
	A6	DOUT 14	B6	DIN 14
	A7	DOUT 13	B7	DIN 13
	A8	DOUT 12	B8	DIN 12
	A9	DOUT 11	B9	DIN 11
	A10	DOUT 10	B10	DIN 10
	A11	DOUT 9	B11	DIN 9
	A12	DOUT 8	B12	DIN 8
	A13	DOUT 7	B13	DIN 7
	A14	DOUT 6	B14	DIN 6
	A15	DOUT 5	B15	DIN 5
	A16	DOUT 4	B16	DIN 4
	A17	DOUT 3	B17	DIN 3
	A18	DOUT 2	B18	DIN 2
	A19	DOUT 1	B19	DIN 1
	A20	DOUT 0	B20	DIN 0

Recommended Connectors and Connector Covers

Connector Type	Connector Model Numbers (made by Fujitsu Takamisawa Component Limited.)
Solder	FCN-361J040-AU (Connector) FCN-360C040-B (Cover)
Crimp	FCN-363J040 (Connector) FCN-363J040-AU/S (Contact) FCN-360C040-B (Cover)
Pressure	FCN-367J040-AU/F (Contact)

Connector Type	Connector Model Numbers (made by Digital Electronics Corporation)
Solder	GLC100-DIOCN01 (Connector / Cover) 5 pieces *1

*1 A set of 5 pieces for FCN-361J040-AU (Connector) / FCN-360C040-B (Cover)

■Input/Output Specifications

	Input	Output
Rated Voltage	DC24V	
Common Lines	1	
Input/Output Points	16	16
Input Signal Display	LED lights when each point turns ON (logical side)	
Isolation Method	Photocoupler Isolation	
External Power Supply	For Signal : DC24V	
Maximum Allowable Voltage	DC26.4V	DC24V +10%
Input/Output Delay Time	OFF to ON: 10ms or less ON to OFF: 10ms or less	OFF to ON: 2ms or less ON to OFF: 2ms or less
Input Rated Current	5mA (24V)	—————
Input Resistance	4.7kΩ	—————
Operation Range	ON Voltage: 21V or more OFF Voltage: 7V or less	—————
Output Method	—————	Source Output
Maximum Load Voltage	—————	0.2A/point, 1.6A/Common
Output Voltage Drop	—————	2.5V or less
Current Leakage (when OFF)	—————	0.4mA or less
Type of Output	—————	Transistor Output
Output Protection Type	—————	Output is unprotected
Internal Fuse	—————	3.5A,125V Chip Fuse (cannot be replaced)
Surge Control Circuit	—————	Diode

Input Circuit

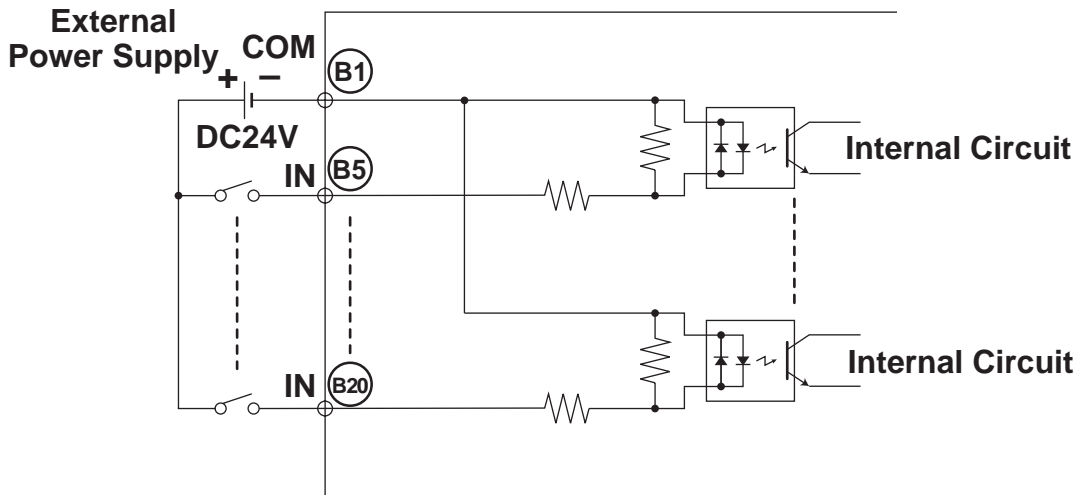

Output Circuit

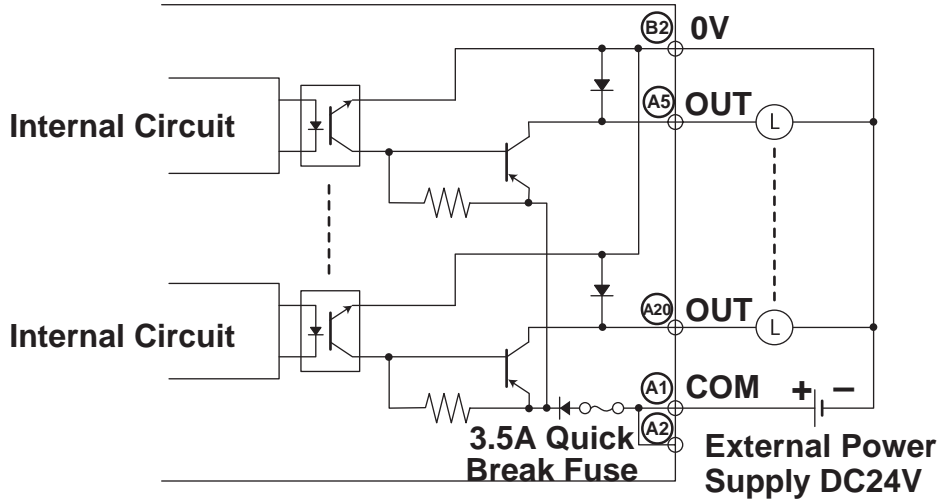

Alarm Output Circuit

Turning the LT unit ON will start the unit's system software and the alarm output circuit's relay. When a major error triggers a watchdog alarm, however, this relay will turn OFF. Since an undefined LogiTouch input or output condition can occur, be sure to design an external failsafe circuit that will monitor the output of this relay.



This relay switch remains OFF until the LT unit's system software completes its startup routine. During this startup period, this external circuit must be informed that the LT is not yet operational. Be sure to design a hold timer circuit that will start operations after the startup routine is completed, or create an alarm monitoring system that will monitor the LT unit's circuits.

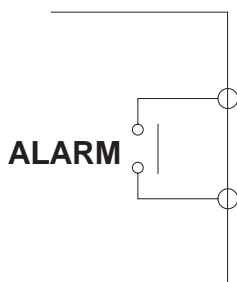

Contact Rating	0.15A, AC125V (Resistance Load) 0.6A, DC24V (Resistance Load)
Operating Time (Set Time at 20°C)	4ms or less
Recover Time (Reset Time at 20°C)	4ms or less
Minimum switching load	1mA / DC5V
Initial Contact Resistance	100mΩ or less

5

Installation

■ Confirm the Installation Gasket's Positioning

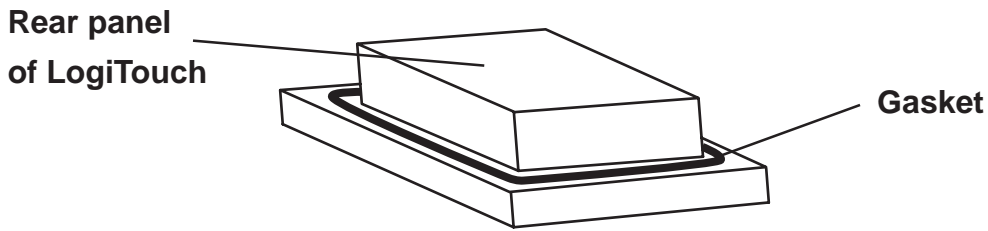

Before installing the LogiTouch into a cabinet or panel, check that the installation gasket is securely attached to the unit.

■ Create a Panel Cut and insert the LogiTouch into the panel from the front

Unit:mm [in.]

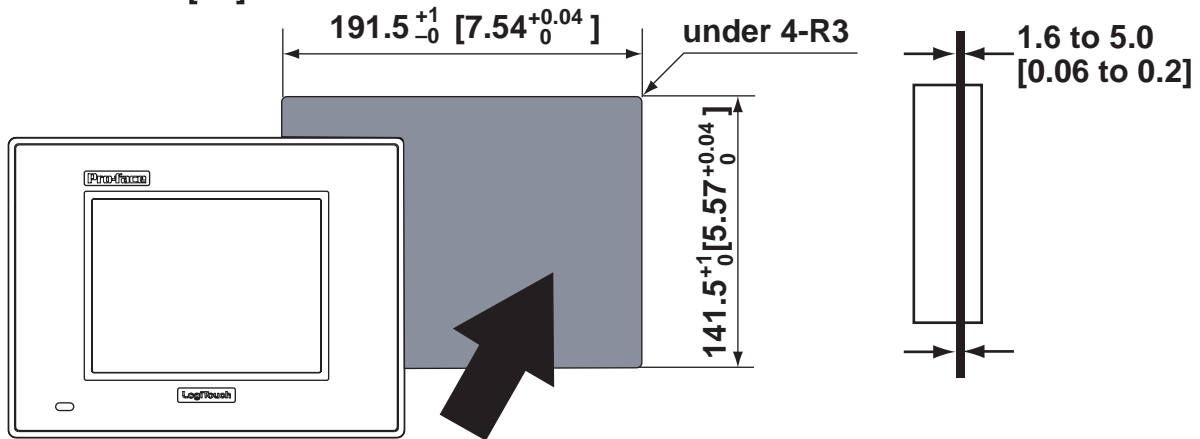

■ Attach the Installation Fasteners from Inside the Panel

The following figures show the four (4) fastener insertion slot locations. Insert each fastener's hook into the slot and pull it back until the hook catches.

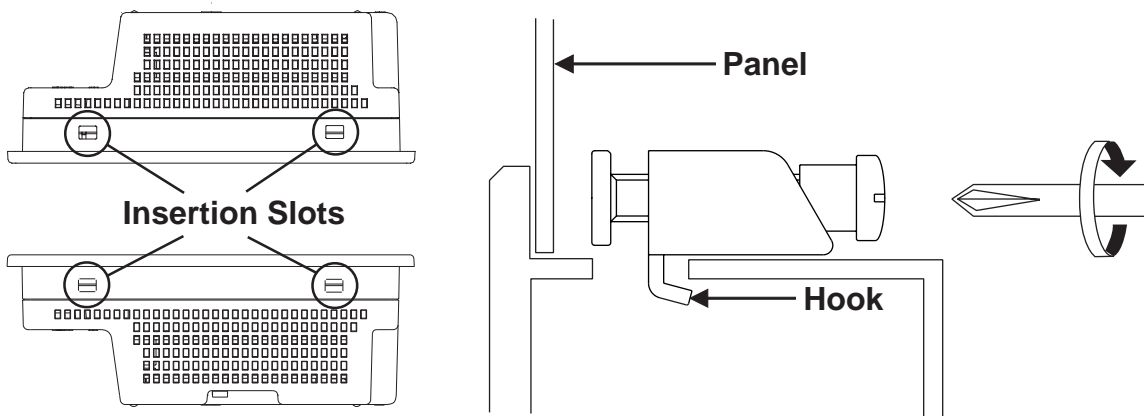

- Tightening the screws with too much force can damage the LogiTouch's plastic case.
- The necessary torque is 0.5Nm.

6

Wiring



WARNINGS

- To prevent an electric shock, prior to connecting the LogiTouch's power cord terminals to the power terminal block, be sure that the LogiTouch's power supply is turned OFF, via a breaker, or similar unit.
- The GLC150-BG41-XY32SC-24V unit is designed to use only DC24V input. Any other power level can damage both the LogiTouch and the power supply.
- To prevent an electric shock or equipment damage, be sure to reattach the plastic cover to the terminal block after completing any wiring.



- To avoid a short caused by loose ring terminals, be sure to use ring terminals with an insulating sleeve.*1
- When the FG terminal is connected, be sure the wire is grounded. Not grounding the LogiTouch unit will result in excess noise and vibration.



- Note:**
- Wherever possible, use thick wires (max. 2 mm²) for power terminals, and twist the wire ends before attaching the ring terminals.
 - Be sure to use the following size ring terminals.

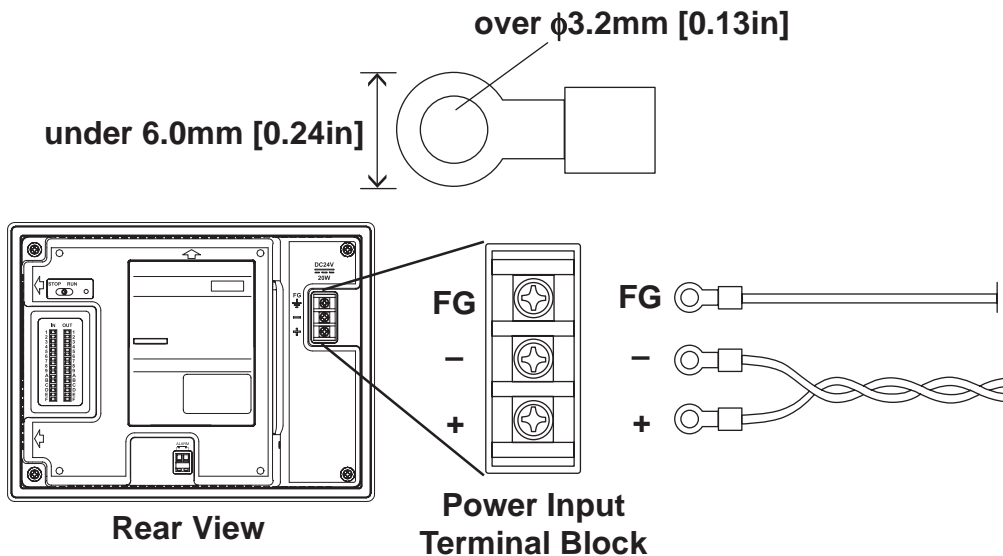

■ Connecting the LogiTouch Power Cord

When connecting the power cord, be sure to follow the procedures given below.

1. Confirm that the LogiTouch's Power Cord is unplugged from the power supply.
2. Use a screwdriver to remove the Power Input Terminal Block's clear plastic cover.
3. Unscrew the screws from the middle three (3) terminals, align the Ring Terminals and reattach the screws.
4. Confirm that the wires are connected correctly.
5. Replace the Power Input Terminal Block's clear plastic cover.



Note: The torque required to tighten these screws is 0.5 to 0.6Nm.

*1 Suggested Ring Terminal : V2-MS3 (made by JST)

7

Power Supply Cautions

Please pay special attention to the following instructions when connecting the power cord terminals to the LogiTouch unit.

- If the power supply voltage exceeds the LogiTouch's specified range, connect a voltage transformer.
- Between the line and the ground, be sure to use a low noise power supply. If there is still an excessive amount of noise, connect a noise reducing transformer.
- Input and Output signal lines must be separated from the power control cables for operational circuits.
- To increase the noise resistance, be sure to twist the ends of the power cord wires before connecting it to the LogiTouch unit.
- The LogiTouch's power supply cord should not be bundled with or kept close to main circuit lines (high voltage, high current), or input/output signal lines.
- Connect a surge absorber to handle power surges.
- To reduce noise, make the power cord as short as possible.

8

Grounding Cautions

- When attaching a wire to the LogiTouch's rear face FG terminal, (on the Power Input Terminal Block), be sure to create an exclusive ground*¹.
- Inside the LogiTouch unit, the SG (Signal Ground) and FG (Frame Ground) terminals are connected to each other.
- When attaching an expansion unit to the LogiTouch, be sure to read the expansion unit's Installation Guide.
- The grounding electric wire must be independent, not crossing over other wires.

9

Input/Output Signal Line Cautions

- All LogiTouch Input and Output signal lines must be separated from all operating circuit (power) cables.
- If this is not possible, use a shielded cable and ground the shield.

10

Maintenance and Periodic Inspection

When dirt collects on the surface or the frame of the display, soak a soft cloth in water with a neutral detergent, wring the cloth tightly, and wipe the display.



- *Do not use paint thinner, organic solvents, or strong acid compound to clean the unit.*
- *Do not use hard or pointed objects to operate the touch-screen panel, since it can damage the panel surface.*

*¹ Use a grounding resistance of 100Ω, a wire of 2mm² or thicker, or your country's applicable standard.