

IT2400-TC41-PSGJ Installation Guide

Thank you for purchasing Proface's IT2400-TC41-PSGJ, hereafter referred to as the "IT" unit.

This guide explains the steps necessary for setting up and operating the IT unit safely. For further details, refer to this guide, and to the PS-400G Series User Manual (PDF manual in the bundled CD-ROM).

Safety Precautions



WARNINGS

System Design

- Do not create switches used to control machine safety operations, such as an emergency stop switch, as a IT touch screen icon. Be sure to install these switches as separate hardware switches, otherwise severe bodily injury or equipment damage can occur.
- Please design your system so that equipment will not malfunction due to a communication fault between the IT and its host controller. This is to prevent any possibility of bodily injury or material damage.
- The IT is not appropriate for use with aircraft control devices, aerospace equipment, central trunk data transmission (communication) devices, nuclear power control devices, or medical life support equipment, due to these devices' inherent requirements of extremely high levels of safety and reliability.
- When using the IT with transportation vehicles (trains, cars and ships), disaster and crime prevention devices, various types of safety equipment, non-life support related medical devices, etc. redundant and/or failsafe system designs should be used to ensure the proper degree of reliability and safety.
- Do not use the IT unit as a warning device for critical alarms that can cause serious operator injury, machine damage or production stoppage. Critical alarm indicators and their control/activator units must be designed using stand-alone hardware and/or mechanical interlocks.
- After the IT's backlight burns out, unlike the IT's "Standby Mode", the touch panel is still active. If the operator fails to notice that the backlight is burned out and touches the panel, a potentially dangerous machine miss-operation can occur. Therefore, do not use IT touch switches for the control of any equipment safety mechanisms, such as Emergency Stop switches, etc. that protect humans and equipment from injury and damage. If your IT's backlight suddenly turns OFF, use the following steps to determine if the backlight is actually burned out.
 - 1) If your IT is not set to "Standby Mode" and the screen has gone blank, your backlight is burned out.
 - 2) Or, if your IT is set to Standby Mode, but touching the screen does not cause the display to reappear, your backlight is burned out.

Also, to prevent accidental machine miss-operation, Proface suggests you use the IT's built-in "USE TOUCH PANEL AFTER BACKLIGHT BURNOUT" feature, that will automatically detect a burnout and disable the touch screen.



WARNINGS

Installation

- High voltage runs through the IT. Except for replacing the backlight, never disassemble the IT, otherwise an electric shock can occur.
- Do not modify the IT unit. Doing so may cause a fire or an electric shock.
- Do not use the IT in an environment where flammable gasses are present, since operating the IT may cause an explosion.

Wiring

- To prevent an electric shock, be sure to confirm that the IT's power cord is not connected to the main power when connecting any cords, cables or lines to the IT.
- Do not use power beyond the IT's specified voltage range. Doing so may cause a fire or an electric shock.

Maintenance

- The IT uses a lithium battery for backing up its internal clock data. If the battery is incorrectly replaced, the battery may explode. To prevent this, please do not replace the battery yourself. Prior to replacing the battery, please contact your local IT distributor.

In order to use the IT unit safely, be sure to refer to the Warning data included in this guide, and to the Warning and Caution data in the PS-400G Series User Manual (PDF manual in the bundled CD-ROM).

UL/c-UL(CSA) Approval

The IT2400-TC41-PSGJ is a UL/c-UL(CSA) listed product.
(UL file No. E171486)

This Unit conforms as a component to the following standards:

UL 1950, Third Edition, dated March 1, 1998

(Standard for Safety of Information Technology Equipment, including Electrical Business Equipment)

CAN-C22.2 No.950-M95

(Standard for Safety of Information Technology Equipment, including Electrical Business Equipment)

IT2400-TC41-PSGJ (UL Registration Model: 2980043-03)

Failure to fulfill the following items may cause the IT unit to fail to meet the conditions of UL/c-UL(CSA) approval.

- The IT unit is to be used indoors.
- Design the IT unit's power cut-off switch as a separate disconnect device and locate it where the operator can easily reach it.
- Be sure to design the plug of the IT unit's power supply so that it is easily removed.
- When creating a cable, be sure the cable is flame-resistant grade (VW-1). Also, check that the rated voltage of the Serial I/F power output terminals is +5V.

CE Marking

The IT2400-TC41-PSGJ is a CE marked, EMC compliant product. This unit conforms to EN55011 ClassA, EN61000-6-2 directives.

FCC Regulations

The IT2400-TC41-PSGJ is a FCC approved product. This unit conforms to FCC regulations, Part 15 ClassA.

Package Contents

Please check that the following items are included in your package.

- IT2400-TC41-PSGJ
- PS-400G Installation Guide
- IT2400-TC41-PSGJ Installation Guide (this guide)
- CD-ROM (PDF Manual)

1 Part Names

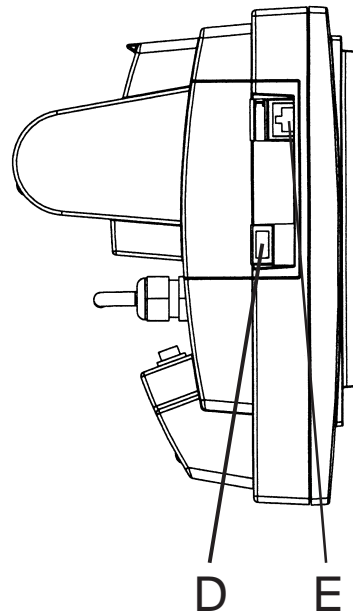
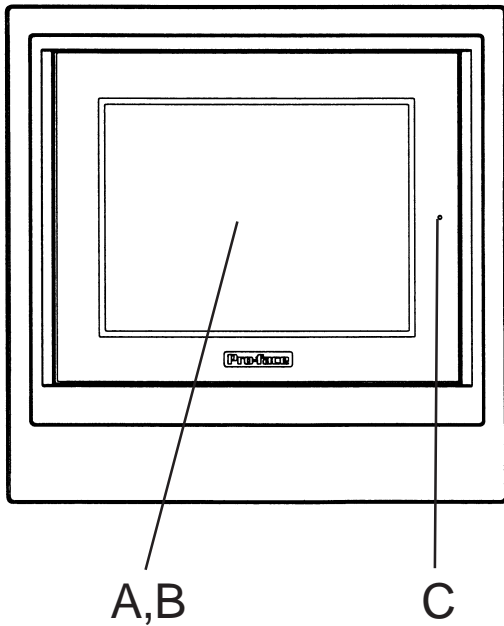

- A : Display
- B : Touch Panel
- C : Status LED
- D : USB I/F (USB)
- E : Ethernet Interface (10BASE-T)
- F : Power Cord
- G : Power Switch
- H : RAS I/F (RAS)
- I : Serial Interface (COM1)
- J : Serial Interface (COM2)
- K : Printer Interface (PIO)
- L : Sound Output Terminal Block
- M: CF Card I/F

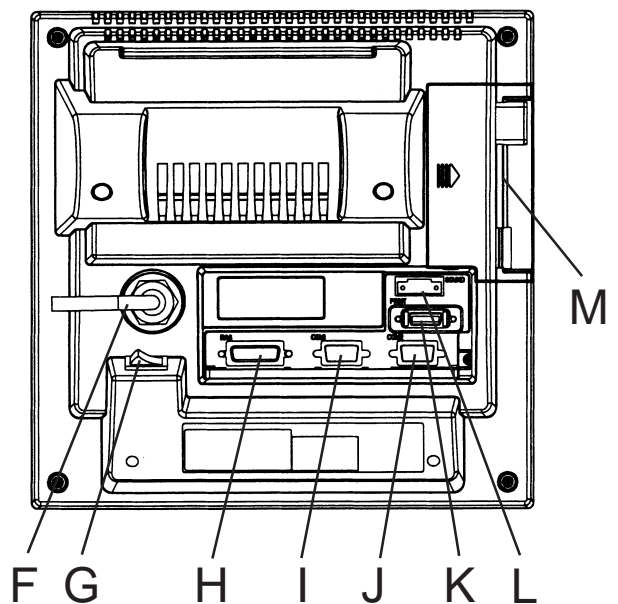

2 Dimensions

Units:mm [in.]

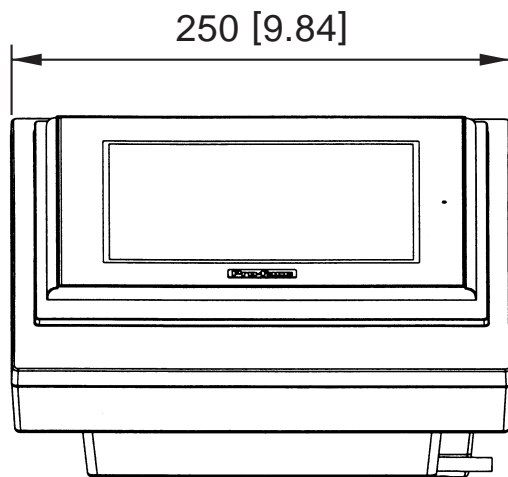

Front

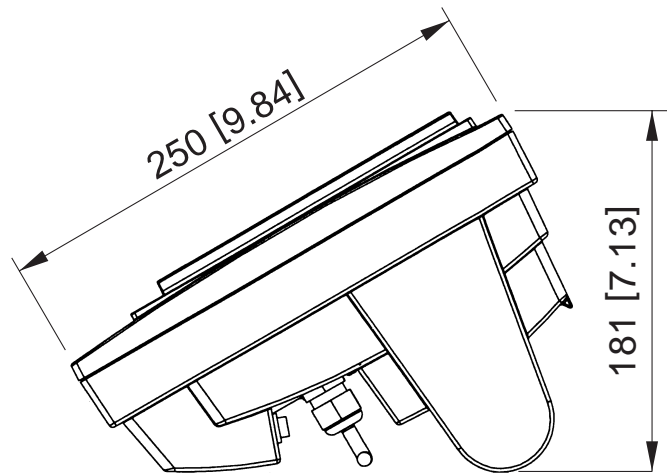

Side

AC Cable Length : 2000mm \pm 150mm

3 Specifications

Rated Voltage	AC100V
Voltage Supply Range	AC85V to AC125V
Allowable Voltage Drop	20ms or less
Power Consumption	70VA or less
Voltage Endurance	AC1500V 20mA for 1 minute
Insulation Resistance	10M Ω or higher at DC500V
Ambient Operating Temperature	0°C to 35°C
Grounding	100 Ω or less, or your country's applicable standard ^{*1}

*1 Grounding requirements differ from country to country. Be sure to confirm your work environment requirements prior to installation. For further information, please contact your Pro-face distributor.

All other IT unit specifications are based on the PS-400G unit's specifications. Also, see the bundled PS-400G Installation Guide.

Note

Please be aware that Digital Electronics Corporation shall not be held liable by the user for any damages, losses, or third party claims arising from the uses of this product.

Digital Electronics Corporation

8-2-52 Nanko Higashi, Suminoe-ku, Osaka 559-0031, Japan

URL: <http://www.pro-face.com/>