



# Temperature Controller Driver

1	System Configuration.....	3
2	Selection of External Device .....	11
3	Example of Communication Setting.....	12
4	Setup Items.....	104
5	Cable Diagram .....	109
6	Supported Device.....	211
7	Device Code and Address Code.....	286
8	Error Messages.....	292

## Introduction

This manual describes how to connect the Display and the External Device (target PLC).

In this manual, the connection procedure will be described by following the below sections:

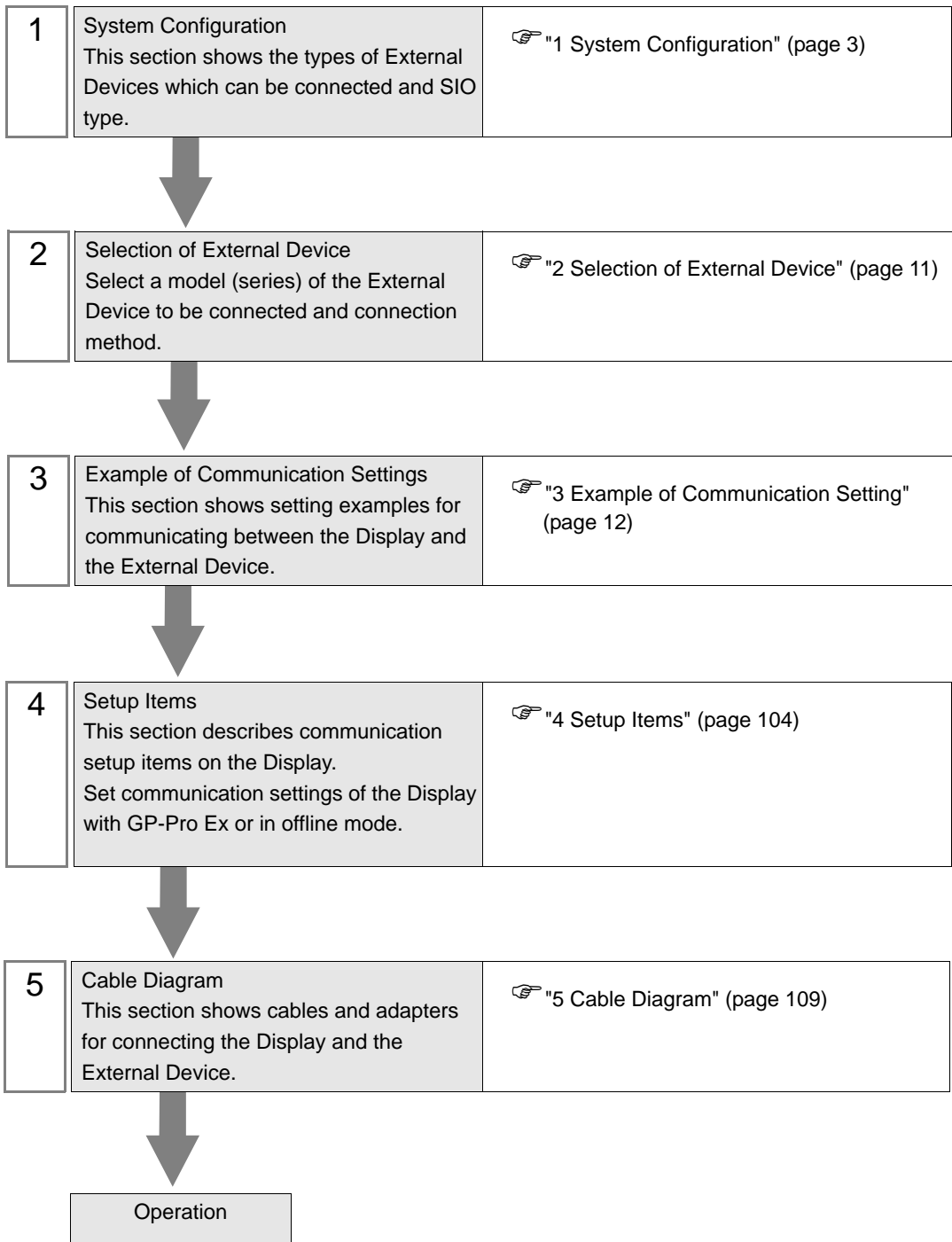

# 1 System Configuration

The system configuration in the case when the External Device of RKC INSTRUMENT INC. and the Display are connected is shown.

Series	CPU*1	Link I/F	SIO Type	Setting Example	Cable Diagram
CB	CB100□□□□-□□*□□-5□/□ CB400□□□□-□□*□□-5□/□ CB500□□□□-□□*□□-5□/□ CB700□□□□-□□*□□-5□/□ CB900□□□□-□□*□□-5□/□	Terminal Block on the controller.	RS422/485 (2 wire)	Setting Example 1 (page 12)	Cable Diagram 1 (page 109)
FB*2	FB900-□□-□*□□□1/□□-□□□□ FB400-□□-□*□□□1/□□-□□□□	Terminal Block on the controller. (Communication 1)	RS232C	Setting Example 2 (page 14)	Cable Diagram 2 (page 117)
	FB900-□□-□*□□□4/□□-□□□□ FB400-□□-□*□□□4/□□-□□□□	Terminal Block on the controller. (Communication 1)	RS422/485 (4 wire)	Setting Example 3 (page 16)	Cable Diagram 10 (page 172)
	FB900-□□-□*□□□5/□□-□□□□ FB400-□□-□*□□□5/□□-□□□□	Terminal Block on the controller. (Communication 1)	RS422/485 (2 wire)	Setting Example 4 (page 18)	Cable Diagram 1 (page 109)
	FB900-□□-□*□□□Y/□□-□□□□ FB400-□□-□*□□□Y/□□-□□□□	Terminal Block on the controller. (Communication 2)			
	FB900-□□-□*□□□X/□□-□□□□ FB400-□□-□*□□□X/□□-□□□□	Terminal Block on the controller. (Communication 1)			
	FB900-□□-□*□□□W/□□-□□□□ FB400-□□-□*□□□W/□□-□□□□	Terminal Block on the controller. (Communication 1)	RS232C	Setting Example 2 (page 14)	Cable Diagram 2 (page 117)
Terminal Block on the controller. (Communication 2)		RS422/485 (2 wire)	Setting Example 4 (page 18)	Cable Diagram 1 (page 109)	

Series	CPU*1	Link I/F	SIO Type	Setting Example	Cable Diagram	
HA*3	HA900-□□-□□-□*□□-□□1□-□/□/□ HA900-□□-□□-□*□□-□□□1-□/□/□ HA901-□□-□□-□*□□-□□1□-□/□/□ HA901-□□-□□-□*□□-□□□1-□/□/□ HA400-□□-□□-□*□□-□□1□-□/□/□ HA400-□□-□□-□*□□-□□□1-□/□/□ HA401-□□-□□-□*□□-□□1□-□/□/□ HA401-□□-□□-□*□□-□□□1-□/□/□ HA930-□□-□□-□*□□-□1-□/□ HA430-□□-□□-□*□□-□1-□/□	Terminal Block on the controller.	RS232C	Setting Example 5 (page 20)	Cable Diagram 2 (page 117)	
	HA900-□□-□□-□*□□-□□5□-□/□/□ HA900-□□-□□-□*□□-□□□5-□/□/□ HA901-□□-□□-□*□□-□□5□-□/□/□ HA901-□□-□□-□*□□-□□□5-□/□/□ HA400-□□-□□-□*□□-□□5□-□/□/□ HA400-□□-□□-□*□□-□□□5-□/□/□ HA401-□□-□□-□*□□-□□5□-□/□/□ HA401-□□-□□-□*□□-□□□5-□/□/□ HA930-□□-□□-□*□□-□5-□/□ HA430-□□-□□-□*□□-□5-□/□	Terminal Block on the controller.	RS422/485 (2 wire)	Setting Example 6 (page 22)	Cable Diagram 1 (page 109)	
	HA900-□□-□□-□*□□-□□□4-□/□/□ HA901-□□-□□-□*□□-□□□4-□/□/□ HA400-□□-□□-□*□□-□□□4-□/□/□ HA401-□□-□□-□*□□-□□□4-□/□/□ HA930-□□-□□-□*□□-□4-□/□ HA430-□□-□□-□*□□-□4-□/□	Terminal Block on the controller.	RS422/485 (4 wire)*4	Setting Example 7 (page 24)	Cable Diagram 10 (page 172)	
	MA900*3*5	MA900-4□□□□-□□-□*□□□-□5/□ MA901-8□□□□-□□-□*□□□-□5/□	Terminal Block on the controller.	RS422/485 (2 wire)	Setting Example 8 (page 26)	Cable Diagram 1 (page 109)
		MA900-4□□□□-□□-□*□□□-□4/□ MA901-8□□□□-□□-□*□□□-□4/□	Terminal Block on the controller.	RS422/485 (4 wire)	Setting Example 9 (page 28)	Cable Diagram 10 (page 172)
		MA900-4□□□□-□□-□*□□□-□1/□ MA901-8□□□□-□□-□*□□□-□1/□	Terminal Block on the controller.	RS232C	Setting Example 10 (page 30)	Cable Diagram 2 (page 117)
	SRV	V-TIO-A-□□□□-□□*□□□-□□-□-□ V-TIO-C-□□□□-□□*□□□-□□-□-□	Terminal Block on the controller.	RS422/485 (2 wire)	Setting Example 14 (page 38)	Cable Diagram 1 (page 109)
	SRX	X-TIO-A-□□-□□*□□	Terminal Block on the controller.	RS422/485 (2 wire)	Setting Example 15 (page 40)	Cable Diagram 1 (page 109)
	SA100	SA100□□□□-□□-□*□□-5□/□□	Terminal Block on the controller.	RS422/485 (2 wire)	Setting Example 16 (page 42)	Cable Diagram 1 (page 109)
SA200	SA200□□□□-□□-□*□□-5□/□/□□	Terminal Block on the controller.	RS422/485 (2 wire)	Setting Example 17 (page 44)	Cable Diagram 1 (page 109)	



Series	CPU <sup>*1</sup>	Link I/F	SIO Type	Setting Example	Cable Diagram
SR Mini HG (H-PCP-A/B)	H-PCP-□-□1N-□*□□	Modular connector 1 on the controller.	RS232C	Setting Example 38 (page 86)	Cable Diagram 11 (page 177)
	H-PCP-□-□4N-□*□□	Modular connector on the controller.	RS422/485 (4 wire)	Setting Example 39 (page 88)	Cable Diagram 8 (page 159)
SR Mini HG (H-PCP-J)	H-PCP-J-□4□-D*□□	COM.PORT1 and COM.PORT2 on the controller.	RS422/485 (4 wire)	Setting Example 20 (page 50)	Cable Diagram 4 (page 124)
	H-PCP-J-□5□-D*□□		RS422/485 (2 wire)	Setting Example 21 (page 52)	Cable Diagram 5 (page 131)
	H-PCP-J-□□1-D*□□	COM.PORT3 on the controller.	RS232C	Setting Example 22 (page 54)	Cable Diagram 12 (page 179)
	H-PCP-J-□□4-D*□□		RS422/485 (4 wire)	Setting Example 20 (page 50)	Cable Diagram 6 (page 141)
	H-PCP-J-□□5-D*□□		RS422/485 (2 wire)	Setting Example 21 (page 52)	Cable Diagram 7 (page 148)
REX-F9000	F9000-□□□-□*□□/□	Terminal Block on the controller.	RS422/485 (2 wire)	Setting Example 13 (page 36)	Cable Diagram 1 (page 109)
REX-F	F400□□□-□□*□□-□□□-1□ F700□□□-□□*□□-□□□-1□ F900□□□-□□*□□-□□□-1□	Terminal Block on the controller.	RS232C	Setting Example 23 (page 56)	Cable Diagram 2 (page 117)
	F400□□□-□□*□□-□□□-4□ F700□□□-□□*□□-□□□-4□ F900□□□-□□*□□-□□□-4□	Terminal Block on the controller.	RS422/485 (4 wire)	Setting Example 24 (page 58)	Cable Diagram 10 (page 172)
	F400□□□-□□*□□-□□□-5□ F700□□□-□□*□□-□□□-5□ F900□□□-□□*□□-□□□-5□	Terminal Block on the controller.	RS422/485 (2 wire)	Setting Example 25 (page 60)	Cable Diagram 1 (page 109)
REX-D	D400□-□*□□-□-4 D700□-□*□□-□-4 D900□-□*□□-□-4	Terminal Block on the controller.	RS422/485 (4 wire)	Setting Example 18 (page 46)	Cable Diagram 3 (page 119)
	D100□-□□*□□-□□-5□ D400□-□*□□-□-5 D700□-□*□□-□-5 D900□-□*□□-□-5	Terminal Block on the controller.	RS422/485 (2 wire)	Setting Example 19 (page 48)	Cable Diagram 1 (page 109)

Series	CPU*1	Link I/F	SIO Type	Setting Example	Cable Diagram
REX-G9	G9□□□□-□*□□□□-□□-1/A	Terminal Block on the controller.	RS232C	Setting Example 26 (page 62)	Cable Diagram 2 (page 117)
	G9□□□□-□*□□□□-□□-4/A	Terminal Block on the controller.	RS422/485 (4 wire)	Setting Example 27 (page 64)	Cable Diagram 10 (page 172)
	G9□□□□-□*□□□□-□□-2/A	Terminal Block on the controller.	RS422/485 (2 wire)	Setting Example 28 (page 66)	Cable Diagram 9 (page 164)
REX-P300	P300□□□□-□□□□*D-□□□□□-1	Terminal Block on the controller.	RS232C	Setting Example 29 (page 68)	Cable Diagram 2 (page 117)
	P300□□□□-□□□□*D-□□□□□-4	Terminal Block on the controller.	RS422/485 (4 wire)	Setting Example 30 (page 70)	Cable Diagram 3 (page 119)
	P300□□□□-□□□□*D-□□□□□-5	Terminal Block on the controller.	RS422/485 (2 wire)	Setting Example 31 (page 72)	Cable Diagram 1 (page 109)
REX-P250	P250□□□□-□*□□□□-1	Terminal Block on the controller.	RS232C	Setting Example 32 (page 74)	Cable Diagram 2 (page 117)
	P250□□□□-□*□□□□-2	Terminal Block on the controller.	RS422/485 (2 wire)	Setting Example 33 (page 76)	Cable Diagram 9 (page 164)
REX-AD	AD410□□□□*□□□□-4/CE	Terminal Block on the controller.	RS422/485 (4 wire)	Setting Example 34 (page 78)	Cable Diagram 3 (page 119)
	AD410□□□□*□□□□-5/CE	Terminal Block on the controller.	RS422/485 (2 wire)	Setting Example 35 (page 80)	Cable Diagram 1 (page 109)
REX-PG	PG410□□□□*□□□□-□4	Terminal Block on the controller.	RS422/485 (4 wire)	Setting Example 36 (page 82)	Cable Diagram 3 (page 119)
	PG410□□□□*□□□□-□5	Terminal Block on the controller.	RS422/485 (2 wire)	Setting Example 37 (page 84)	Cable Diagram 1 (page 109)
AE500	AE500□□□□-□*□□□□□-5□□□□	Terminal Block on the controller.	RS422/485 (2 wire)	Setting Example 11 (page 32)	Cable Diagram 1 (page 109)
LE100	LE100-□□□□*□5□□□□-□□□□	Terminal Block on the controller.	RS422/485 (2 wire)	Setting Example 12 (page 34)	Cable Diagram 1 (page 109)

Series	CPU*1	Link I/F	SIO Type	Setting Example	Cable Diagram
SRZ (Z-TIO)	Z-TIO-A□-□□□□/□□-□□□□ Z-TIO-B□-□□/□N□-□□□□ Z-TIO-C□-□□□□/□□-□□□□ Z-TIO-D□-□□/□N□-□□□□	Terminal Block on the controller.	RS422/485 (2 wire)	Setting Example 40 (page 90)	Cable Diagram 13 (page 181)
SRZ (Z-DIO)	Z-DIO-A□-□□/□-□□□□□□□□ Z-DIO-A□-□□/□N	Terminal Block on the controller.	RS422/485 (2 wire)	Setting Example 41 (page 92)	Cable Diagram 13 (page 181)
SRZ (Z-CT)	Z-CT-A□/□-□□ Z-CT-A□/□N	Terminal Block on the controller.	RS422/485 (2 wire)	Setting Example 42 (page 94)	Cable Diagram 13 (page 181)
SRZ (Z-COM)	Z-COM-A-4□/□□□□ Z-COM-A-4□/□N	COM.PORT1 COM.PORT2 on the controller.	RS422/485 (4 wire)	Setting Example 43 (page 96)	Cable Diagram 14 (page 192)
	Z-COM-A-5□/□□□□ Z-COM-A-5□/□N		RS422/485 (2 wire)	Setting Example 44 (page 98)	Cable Diagram 15 (page 199)
	Z-COM-A-□4/□□□□ Z-COM-A-□4/□N	COM.PORT3 COM.PORT4 on the controller	RS422/485 (4 wire)	Setting Example 45 (page 100)	Cable Diagram 14 (page 192)
	Z-COM-A-□5/□□□□ Z-COM-A-□5/□N		RS422/485 (2wire)	Setting Example 46 (page 102)	Cable Diagram 15 (page 199)

\*1 The mode data "□" will vary depending on the type of option.

\*2 There are two communication port: Communication 1 and Communication 2.

Communication 1 is used for host communication. Communication 2 is used for intercontroller communication, but can be also used for host communication. When Communication 2 is used for host communication, it is necessary to change the protocol of Communication 2 (RKC communication is set).

\*3 No memory area number is specified, "Control area" is used as default.

\*4 Only Communication 2 supports RS-422 connection.

\*5 Only support Single mode, Multi-point mode hasn't been supported.

## ■ Connection Configuration

- 1:1 Connection



- 1:n Connection

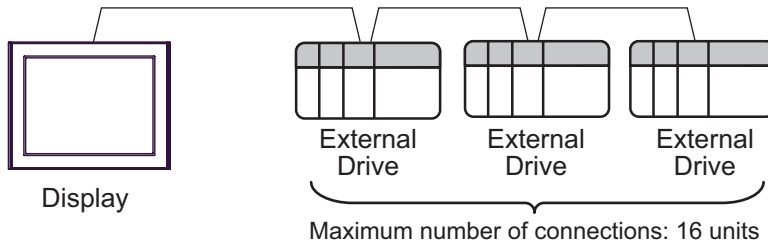

- 1:n Connection (For the SRZ (Z-TIO), SRZ (Z-DIO), and SRZ (Z-CT) Series)

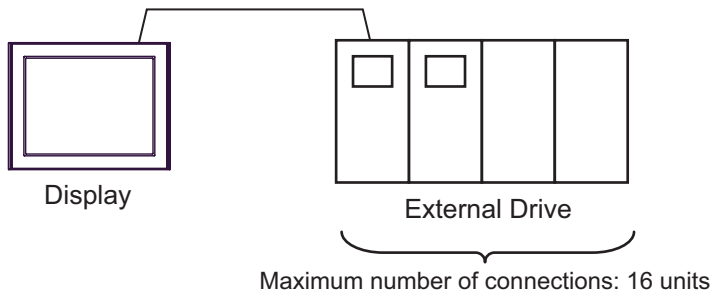

- 1:n Connection (For the SRZ (Z-COM) Series)

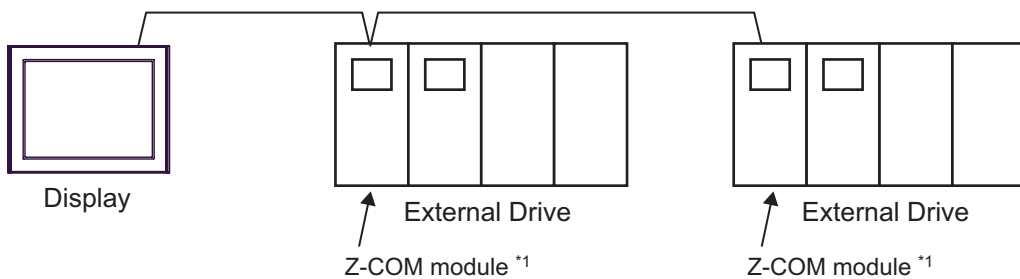

\*1 Up to 16 Z-COM modules can be connected.

## ■ IPC COM Port

When connecting IPC with an External Device, the COM port used depends on the series and SIO type. Please refer to the IPC manual for details.

Usable port

Series	Usable Port		
	RS-232C	RS-422/485(4 wire)	RS-422/485(2 wire)
PS-2000B	COM1 <sup>*1</sup> , COM2, COM3 <sup>*1</sup> , COM4	-	-
PS-3450A, PS-3451A, PS3000-BA, PS3001-BD	COM1, COM2 <sup>*1*2</sup>	COM2 <sup>*1*2</sup>	COM2 <sup>*1*2</sup>
PS-3650A (T41 model), PS-3651A (T41 model)	COM1 <sup>*1</sup>	-	-
PS-3650A (T42 model), PS-3651A (T42 model)	COM1 <sup>*1*2</sup> , COM2	COM1 <sup>*1*2</sup>	COM1 <sup>*1*2</sup>
PS-3700A (Pentium®4-M) PS-3710A	COM1 <sup>*1</sup> , COM2 <sup>*1</sup> , COM3 <sup>*2</sup> , COM4	COM3 <sup>*2</sup>	COM3 <sup>*2</sup>
PS-3711A	COM1 <sup>*1</sup> , COM2 <sup>*2</sup>	COM2 <sup>*2</sup>	COM2 <sup>*2</sup>
PS4000 <sup>*3</sup>	COM1, COM2	-	-
PL3000	COM1 <sup>*1*2</sup> , COM2 <sup>*1</sup> , COM3, COM4	COM1 <sup>*1*2</sup>	COM1 <sup>*1*2</sup>

\*1 The RI/5V can be switched. Use the IPC's switch to change if necessary.

\*2 Set up the SIO type with the DIP Switch. Please set up as follows according to SIO type to be used.

\*3 When making communication between an External Device and COM port on the Expansion slot, only RS-232C is supported. However, ER (DTR/CTS) control cannot be executed because of the specification of COM port.

For connection with External Device, use user-created cables and disable Pin Nos. 1, 4, 6 and 9.

Please refer to the IPC manual for details of pin layout.

DIP Switch setting: RS-232C

DIP Switch	Setting	Description
1	OFF <sup>*1</sup>	Reserved (always OFF)
2	OFF	SIO type: RS-232C
3	OFF	
4	OFF	Output mode of SD (TXD) data: Always output
5	OFF	Terminal resistance (220Ω) insertion to SD (TXD): None
6	OFF	Terminal resistance (220Ω) insertion to RD (RXD): None
7	OFF	Short-circuit of SDA (TXA) and RDA (RXA): Not available
8	OFF	Short-circuit of SDB (TXB) and RDB (RXB): Not available
9	OFF	RS (RTS) Auto control mode: Disabled
10	OFF	

\*1 When using PS-3450A, PS-3451A, PS3000-BA and PS3001-BD, turn ON the set value.

## DIP Switch setting: RS-422/485 (4 wire)

DIP Switch	Setting	Description
1	OFF	Reserved (always OFF)
2	ON	SIO type: RS-422/485
3	ON	
4	OFF	Output mode of SD (TXD) data: Always output
5	OFF	Terminal resistance (220Ω) insertion to SD (TXD): None
6	OFF	Terminal resistance (220Ω) insertion to RD (RXD): None
7	OFF	Short-circuit of SDA (TXA) and RDA (RXA): Not available
8	OFF	Short-circuit of SDB (TXB) and RDB (RXB): Not available
9	OFF	RS (RTS) Auto control mode: Disabled
10	OFF	

## DIP Switch setting: RS-422/485 (2 wire)

DIP Switch	Setting	Description
1	OFF	Reserved (always OFF)
2	ON	SIO type: RS-422/485
3	ON	
4	OFF	Output mode of SD (TXD) data: Always output
5	OFF	Terminal resistance (220Ω) insertion to SD (TXD): None
6	OFF	Terminal resistance (220Ω) insertion to RD (RXD): None
7	ON	Short-circuit of SDA (TXA) and RDA (RXA): Available
8	ON	Short-circuit of SDB (TXB) and RDB (RXB): Available
9	ON	RS (RTS) Auto control mode: Enabled
10	ON	

## 2 Selection of External Device

Select the External Device to be connected to the Display.

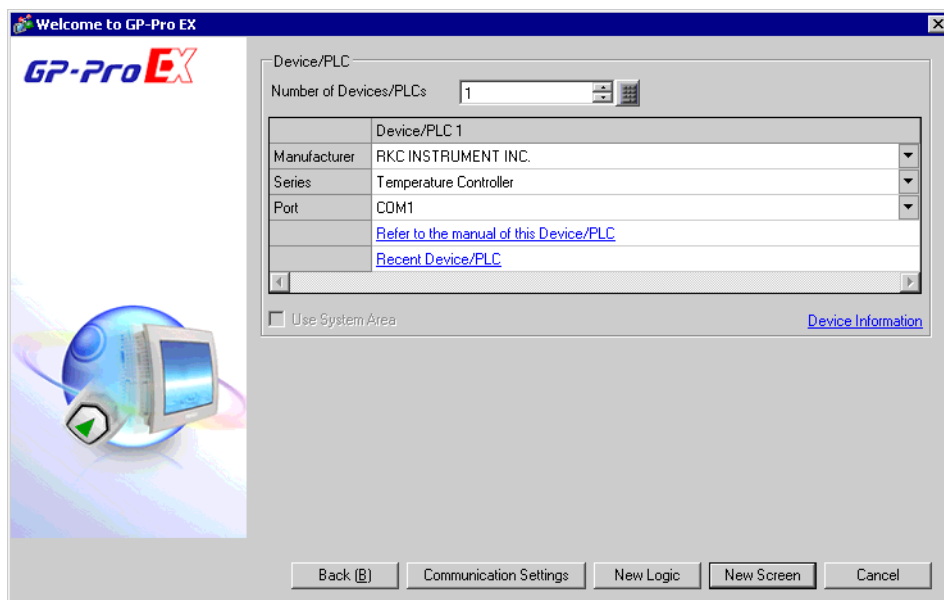

Setup Items	Setup Description
Number of Devices/PLCs	Use an integer from 1 to 4 to enter the number of Devices/PLCs to connect to the Display.
Manufacturer	Select the manufacturer of the External Device to be connected. Select "RKC INSTRUMENT INC.".
Series	Select the model (series) of the External Device to be connected and connection method. Select "Temperature Controller". In the System Configuration, check to make sure the External Device you are connecting is supported in "Temperature Controller". ☞ "1 System Configuration" (page 3)
Port	Select the port of the Display to be connected to the External Device.
Use System Area	Not available in this driver.

## 3 Example of Communication Setting

Examples of communication settings of the Display and the External Device, recommended by Pro-face, are shown.

### 3.1 Setting Example 1

#### ■ Settings of GP-Pro EX

##### ◆ Communication Settings

To display the setup screen, from the [Project] menu, point to [System Settings] and select [Device/PLC].

- NOTE** • Setting value for Wait To Send differs depending on the External Device. Please refer to the manual of the External Device for more details.

##### ◆ Device Setting

To display the [Individual Device Settings] dialog box, from [Device-Specific Settings] in the [Device/PLC] window, select the external device and click [Settings] .

To connect multiple External Devices, from [Device-Specific Settings] in the [Device/PLC] window, click [Add Device] to add another External Device.



## ■ Settings of External Device

Communication setting of the external device is set with the SET, Shift, UP and Down keys located on the front face of the temperature controller.

Please refer to the temperature controller manual for details.

### ◆ Procedure

1. While depressing the SET key, press the Shift key to change from PV/SV display mode to communication setting mode.
2. Press the SET key and select parameters.
3. Press UP/Down keys to change the setting.
4. While depressing the SET key, press Shift key to change from communication setting mode to PV/SV display mode.
5. Turn off power to the temperature controller and turn on again to set the setting.

### ◆ Setting value

Add	0
bPS	2
bIT	0

---

**NOTE** • Parameters to be set differ per temperature controller. Please refer to the temperature controller manual for details.

---

## 3.2 Setting Example 2

### ■ Settings of GP-Pro EX

#### ◆ Communication Settings

To display the setup screen, from the [Project] menu, point to [System Settings] and select [Device/PLC].

**NOTE** • Setting value for Wait To Send differs depending on the External Device. Please refer to the manual of the External Device for more details.

#### ◆ Device Setting

To display the [Individual Device Settings] dialog box, from [Device-Specific Settings] in the [Device/PLC] window, select the external device and click [Settings] .

To connect multiple External Devices, from [Device-Specific Settings] in the [Device/PLC] window, click [Add Device] to add another External Device.

## ■ Settings of External Device

Communication setting of the external device is set with the SET, Shift, UP and Down keys located on the front face of the temperature controller.

Please refer to the temperature controller manual for details.

### ◆ Procedure

1. While depressing the SET key, press the Shift key and hold until display mode changes from PV/SV display mode to engineering mode.
2. Press the Up key several times to set the F60, and press the SET key.
3. Set 0 (zero) to CMP1.
4. While depressing the SET key, press the Shift key to change from engineering mode to PV/SV display mode.
5. While depressing the SET key, press the Shift key to change from PV/SV display mode to setup setting mode.
6. Press the SET key several times to select the parameter.
7. Press Up/Down keys to change the setting.
8. While depressing the SET key, press the Shift key to change from setup setting mode to PV/SV display mode.
9. Turn off power of the temperature controller and turn on again to set the setting.

### ◆ Setting value

Add1	0
bPS1	19.2
bIT1	8n1

#### **NOTE**

- Parameters to be set differ per temperature controller. Please refer to the temperature controller manual for details.

### 3.3 Setting Example 3

#### ■ Settings of GP-Pro EX

##### ◆ Communication Settings

To display the setup screen, from the [Project] menu, point to [System Settings] and select [Device/PLC].

Device/PLC 1

Summary [Change Device/PLC](#)

Manufacturer  Series  Port

Text Data Mode  [Change](#)

Communication Settings

SID Type  RS232C  RS422/485(2wire)  RS422/485(4wire)

Speed

Data Length  7  8

Parity  NONE  EVEN  ODD

Stop Bit  1  2

Flow Control  NONE  ER(DTR/CTS)  XON/XOFF

Timeout  (sec)

Retry

Wait To Send  (ms)

RI / VCC  RI  VCC

In the case of RS232C, you can select the 9th pin to RI (Input) or VCC (5V Power Supply). If you use the Digital's RS232C Isolation Unit, please select it to VCC.

Device-Specific Settings

Allowable Number of Devices/PLCs  [Add Device](#)

No.	Device Name	Settings	Add Indirect Device
<input type="button" value="1"/>	<input type="text" value="PLC1"/>	<input type="text" value="Series=FB,Device Address=0"/>	<input type="button" value="+"/>

**NOTE** • Setting value for Wait To Send differs depending on the External Device. Please refer to the manual of the External Device for more details.

##### ◆ Device Setting

To display the [Individual Device Settings] dialog box, from [Device-Specific Settings] in the [Device/PLC] window, select the external device and click [Settings] .

To connect multiple External Devices, from [Device-Specific Settings] in the [Device/PLC] window, click [Add Device] to add another External Device.

Individual Device Settings

PLC1

Series

Device Address

## ■ Settings of External Device

Communication setting of the external device is set with the SET, Shift, UP and Down keys located on the front face of the temperature controller.

Please refer to the temperature controller manual for details.

### ◆ Procedure

1. While depressing the SET key, press the Shift key and hold until display mode changes from PV/SV display mode to engineering mode.
2. Press the Up key several times to set the F60, and press the SET key.
3. Set 0 (zero) to CMP1.
4. While depressing the SET key, press the Shift key to change from engineering mode to PV/SV display mode.
5. While depressing the SET key, press the Shift key to change from PV/SV display mode to setup setting mode.
6. Press the SET key several times to select the parameter.
7. Press Up/Down keys to change the setting.
8. While depressing the SET key, press the Shift key to change from setup setting mode to PV/SV display mode.
9. Turn off power of the temperature controller and turn on again to set the setting.

### ◆ Setting value

Add1	0
bPS1	19.2
bIT1	8n1

#### **NOTE**

- Parameters to be set differ per temperature controller. Please refer to the temperature controller manual for details.

### 3.4 Setting Example 4

#### ■ Settings of GP-Pro EX

##### ◆ Communication Settings

To display the setup screen, from the [Project] menu, point to [System Settings] and select [Device/PLC].

**NOTE** • Setting value for Wait To Send differs depending on the External Device. Please refer to the manual of the External Device for more details.

##### ◆ Device Setting

To display the [Individual Device Settings] dialog box, from [Device-Specific Settings] in the [Device/PLC] window, select the external device and click [Settings] .

To connect multiple External Devices, from [Device-Specific Settings] in the [Device/PLC] window, click [Add Device] to add another External Device.

## ■ Settings of External Device

Communication setting of the external device is set with the SET, Shift, UP and Down keys located on the front face of the temperature controller.

Please refer to the temperature controller manual for details.

### ◆ Procedure

1. While depressing the SET key, press the Shift key and hold until display mode changes from PV/SV display mode to engineering mode.
2. Press the Up key several times to set the F60, and press the SET key.
3. Set 0 (zero) to CMP1.
4. While depressing the SET key, press the Shift key to change from engineering mode to PV/SV display mode.
5. While depressing the SET key, press the Shift key to change from PV/SV display mode to setup setting mode.
6. Press the SET key several times to select the parameter.
7. Press Up/Down keys to change the setting.
8. While depressing the SET key, press the Shift key to change from setup setting mode to PV/SV display mode.
9. Turn off power of the temperature controller and turn on again to set the setting.

### ◆ Setting value

Add1	0
bPS1	19.2
bIT1	8n1

#### **NOTE**

- Parameters to be set differ per temperature controller. Please refer to the temperature controller manual for details.

## 3.5 Setting Example 5

### ■ Settings of GP-Pro EX

#### ◆ Communication Settings

To display the setup screen, from the [Project] menu, point to [System Settings] and select [Device/PLC].

**NOTE** • Setting value for Wait To Send differs depending on the External Device. Please refer to the manual of the External Device for more details.

#### ◆ Device Setting

To display the [Individual Device Settings] dialog box, from [Device-Specific Settings] in the [Device/PLC] window, select the external device and click [Settings] .

To connect multiple External Devices, from [Device-Specific Settings] in the [Device/PLC] window, click [Add Device] to add another External Device.



## ■ Settings of External Device

Communication setting of the external device is set with the SET, Shift, UP and Down keys located on the front face of the temperature controller.

Please refer to the temperature controller manual for details.

### ◆ Procedure

1. While depressing the SET key, press the Shift key to change from SV setting & monitor mode to setup setting mode.
2. Press the SET key and select parameters.
3. Press UP/Down keys to change the setting.
4. While depressing the SET key, press Shift key to change from setup setting mode to SV setting & monitor mode.
5. Turn off power to the temperature controller and turn on again to set the setting.

### ◆ Setting value

Add1	0
bPS1	9.6
bIT1	8n1

#### **NOTE**

- Parameters to be set differ per temperature controller. Please refer to the temperature controller manual for details.

## 3.6 Setting Example 6

### ■ Settings of GP-Pro EX

#### ◆ Communication Settings

To display the setup screen, from the [Project] menu, point to [System Settings] and select [Device/PLC].

Device/PLC 1

Summary [Change Device/PLC](#)

Manufacturer  Series  Port

Text Data Mode  [Change](#)

Communication Settings

SID Type  RS232C  RS422/485(2wire)  RS422/485(4wire)

Speed

Data Length  7  8

Parity  NONE  EVEN  ODD

Stop Bit  1  2

Flow Control  NONE  ER(DTR/CTS)  XON/XOFF

Timeout  (sec)

Retry

Wait To Send  (ms)

RI / VCC  RI  VCC

In the case of RS232C, you can select the 9th pin to RI (Input) or VCC (5V Power Supply). If you use the Digital's RS232C Isolation Unit, please select it to VCC.

Device-Specific Settings

Allowable Number of Devices/PLCs  [Add Device](#)

No.	Device Name	Settings	Add Indirect Device
<input type="button" value="1"/>	<input type="text" value="PLC1"/>	<input type="text" value="Series=HA, Device Address=0"/>	<input type="button" value="+"/>

**NOTE** • Setting value for Wait To Send differs depending on the External Device. Please refer to the manual of the External Device for more details.

#### ◆ Device Setting

To display the [Individual Device Settings] dialog box, from [Device-Specific Settings] in the [Device/PLC] window, select the external device and click [Settings] .

To connect multiple External Devices, from [Device-Specific Settings] in the [Device/PLC] window, click [Add Device] to add another External Device.

Individual Device Settings

PLC1

Series

Device Address

## ■ Settings of External Device

Communication setting of the external device is set with the SET, Shift, UP and Down keys located on the front face of the temperature controller.

Please refer to the temperature controller manual for details.

### ◆ Procedure

1. While depressing the SET key, press the Shift key to change from SV setting & monitor mode to setup setting mode.
2. Press the SET key and select parameters.
3. Press UP/Down keys to change the setting.
4. While depressing the SET key, press Shift key to change from setup setting mode to SV setting & monitor mode.
5. Turn off power to the temperature controller and turn on again to set the setting.

### ◆ Setting value

Add1	0
bPS1	9.6
bIT1	8n1

#### NOTE

- Parameters to be set differ per temperature controller. Please refer to the temperature controller manual for details.

## 3.7 Setting Example 7

### ■ Settings of GP-Pro EX

#### ◆ Communication Settings

To display the setup screen, from the [Project] menu, point to [System Settings] and select [Device/PLC].

**NOTE** • Setting value for Wait To Send differs depending on the External Device. Please refer to the manual of the External Device for more details.

#### ◆ Device Setting

To display the [Individual Device Settings] dialog box, from [Device-Specific Settings] in the [Device/PLC] window, select the external device and click [Settings] .

To connect multiple External Devices, from [Device-Specific Settings] in the [Device/PLC] window, click [Add Device] to add another External Device.

## ■ Settings of External Device

Communication setting of the external device is set with the SET, Shift, UP and Down keys located on the front face of the temperature controller.

Please refer to the temperature controller manual for details.

### ◆ Procedure

1. While depressing the SET key, press the Shift key to change from SV setting & monitor mode to setup setting mode.
2. Press the SET key and select parameters.
3. Press UP/Down keys to change the setting.
4. While depressing the SET key, press Shift key to change from setup setting mode to SV setting & monitor mode.
5. Turn off power to the temperature controller and turn on again to set the setting.

### ◆ Setting value

Add1	0
bPS1	9.6
bIT1	8n1

**NOTE**

- Parameters to be set differ per temperature controller. Please refer to the temperature controller manual for details.

## 3.8 Setting Example 8

### ■ Settings of GP-Pro EX

#### ◆ Communication Settings

To display the setup screen, from the [Project] menu, point to [System Settings] and select [Device/PLC].

**NOTE** • Setting value for Wait To Send differs depending on the External Device. Please refer to the manual of the External Device for more details.

#### ◆ Device Setting

To display the [Individual Device Settings] dialog box, from [Device-Specific Settings] in the [Device/PLC] window, select the external device and click [Settings] .

To connect multiple External Devices, from [Device-Specific Settings] in the [Device/PLC] window, click [Add Device] to add another External Device.

## ■ Settings of External Device

Communication setting of the external device is set with the SET, Shift, UP and Down keys located on the front face of the temperature controller.

Please refer to the temperature controller manual for details.

### ◆ Procedure

1. While depressing the SET key, press the <R/S key to change from PV/SV display mode to setup setting mode.
2. Press the SET key and select parameters.
3. Press UP/Down keys and <R/S key to change the setting.
4. While depressing the SET key, press <R/S key to change from setup setting mode to PV/SV display mode.
5. Turn off power to the temperature controller and turn on again to set the setting.

### ◆ Setting value

Add	0
bPS	960
bIT	8n1

**NOTE**

- Parameters to be set differ per temperature controller. Please refer to the temperature controller manual for details.

### 3.9 Setting Example 9

#### ■ Settings of GP-Pro EX

##### ◆ Communication Settings

To display the setup screen, from the [Project] menu, point to [System Settings] and select [Device/PLC].

**NOTE** • Setting value for Wait To Send differs depending on the External Device. Please refer to the manual of the External Device for more details.

##### ◆ Device Setting

To display the [Individual Device Settings] dialog box, from [Device-Specific Settings] in the [Device/PLC] window, select the external device and click [Settings] .

To connect multiple External Devices, from [Device-Specific Settings] in the [Device/PLC] window, click [Add Device] to add another External Device.



## ■ Settings of External Device

Communication setting of the external device is set with the SET, Shift, UP and Down keys located on the front face of the temperature controller.

Please refer to the temperature controller manual for details.

### ◆ Procedure

1. While depressing the SET key, press the <R/S key to change from PV/SV display mode to setup setting mode.
2. Press the SET key and select parameters.
3. Press UP/Down keys and <R/S key to change the setting.
4. While depressing the SET key, press <R/S key to change from setup setting mode to PV/SV display mode.
5. Turn off power to the temperature controller and turn on again to set the setting.

### ◆ Setting value

Add	0
bPS	960
bIT	8n1

#### **NOTE**

- Parameters to be set differ per temperature controller. Please refer to the temperature controller manual for details.

### 3.10 Setting Example 10

#### ■ Settings of GP-Pro EX

##### ◆ Communication Settings

To display the setup screen, from the [Project] menu, point to [System Settings] and select [Device/PLC].

Device/PLC 1

Summary [Change Device/PLC](#)

Manufacturer  Series  Port

Text Data Mode  [Change](#)

Communication Settings

SI0 Type  RS232C  RS422/485(2wire)  RS422/485(4wire)

Speed

Data Length  7  8

Parity  NONE  EVEN  ODD

Stop Bit  1  2

Flow Control  NONE  ER(DTR/CTS)  XON/XOFF

Timeout  (sec)

Retry

Wait To Send  (ms)

RI / VCC  RI  VCC

In the case of RS232C, you can select the 9th pin to RI (Input) or VCC (5V Power Supply). If you use the Digital's RS232C Isolation Unit, please select it to VCC.

Device-Specific Settings

Allowable Number of Devices/PLCs: 16 [Add Device](#)

No.	Device Name	Settings
<input type="button" value="1"/>	<input type="text" value="PLC1"/>	<input type="text" value="Series=MA,Device Address=0"/> <input type="button" value="Settings"/>

**NOTE** • Setting value for Wait To Send differs depending on the External Device. Please refer to the manual of the External Device for more details.

##### ◆ Device Setting

To display the [Individual Device Settings] dialog box, from [Device-Specific Settings] in the [Device/PLC] window, select the external device and click [Settings].

To connect multiple External Devices, from [Device-Specific Settings] in the [Device/PLC] window, click [Add Device] to add another External Device.

Individual Device Settings

PLC1

Series

Device Address

## ■ Settings of External Device

Communication setting of the external device is set with the SET, Shift, UP and Down keys located on the front face of the temperature controller.

Please refer to the temperature controller manual for details.

### ◆ Procedure

1. While depressing the SET key, press the <R/S key to change from PV/SV display mode to setup setting mode.
2. Press the SET key and select parameters.
3. Press UP/Down keys and <R/S key to change the setting.
4. While depressing the SET key, press <R/S key to change from setup setting mode to PV/SV display mode.
5. Turn off power to the temperature controller and turn on again to set the setting.

### ◆ Setting value

Add	0
bPS	960
bIT	8n1

**NOTE**

- Parameters to be set differ per temperature controller. Please refer to the temperature controller manual for details.

### 3.11 Setting Example 11

#### ■ Settings of GP-Pro EX

##### ◆ Communication Settings

To display the setup screen, from the [Project] menu, point to [System Settings] and select [Device/PLC].

- NOTE** • Setting value for Wait To Send differs depending on the External Device. Please refer to the manual of the External Device for more details.

##### ◆ Device Setting

To display the [Individual Device Settings] dialog box, from [Device-Specific Settings] in the [Device/PLC] window, select the external device and click [Settings] .

To connect multiple External Devices, from [Device-Specific Settings] in the [Device/PLC] window, click [Add Device] to add another External Device.

## ■ Settings of External Device

Communication setting of the external device is set with the SET, Shift, UP and Down keys located on the front face of the temperature controller.

Please refer to the temperature controller manual for details.

### ◆ Procedure

1. While depressing the Shift key, press the SET key to change from PV display mode to communication setting mode.  
Device address of setting item is displayed.
2. Press the SET key to display the communication item to be set.  
Every time the SET key is depressed, setting item switches.
3. Press the Shift key to move to the value setting display. Press the Up/Down keys and input the setting value.
4. Press the SET key to register the input value.
5. While depressing the Shift key, press the SET key to change from communication setting mode to PV display mode.

### ◆ Setting value

Add	0
bPS	2
bIT	0

#### **NOTE**

- Parameters to be set differ per temperature controller. Please refer to the temperature controller manual for details.

## 3.12 Setting Example 12

### ■ Settings of GP-Pro EX

#### ◆ Communication Settings

To display the setup screen, from the [Project] menu, point to [System Settings] and select [Device/PLC].

Device/PLC 1

Summary [Change Device/PLC](#)

Manufacturer  Series  Port

Text Data Mode  [Change](#)

Communication Settings

RS232C     RS422/485(2wire)     RS422/485(4wire)

Speed

Data Length  7     8

Parity  NONE     EVEN     ODD

Stop Bit  1     2

Flow Control  NONE     ER(DTR/CTS)     XON/XOFF

Timeout  (sec)

Retry

Wait To Send  (ms)

RI / VCC     RI     VCC

In the case of RS232C, you can select the 9th pin to RI (Input) or VCC (5V Power Supply). If you use the Digital's RS232C Isolation Unit, please select it to VCC.

Device-Specific Settings

Allowable Number of Devices/PLCs  [Add Device](#)

No.	Device Name	Settings	Add Indirect Device
<input type="button" value="1"/>	<input type="text" value="PLC1"/>	<input type="text" value="Series=LE,Device Address=0"/>	<input type="button" value="+"/>

- NOTE** • Setting value for Wait To Send differs depending on the External Device. Please refer to the manual of the External Device for more details.

#### ◆ Device Setting

To display the [Individual Device Settings] dialog box, from [Device-Specific Settings] in the [Device/PLC] window, select the external device and click [Settings] .

To connect multiple External Devices, from [Device-Specific Settings] in the [Device/PLC] window, click [Add Device] to add another External Device.

Individual Device Settings

PLC1

Series

Device Address

## ■ Settings of External Device

Communication setting of the external device is set with the SET, Shift, UP and Down keys located on the front face of the temperature controller.

Please refer to the temperature controller manual for details.

### ◆ Procedure

1. While depressing the Down key, press the SET key to change from PV display mode to device configuration setting mode.

Communication parameter group is displayed.

2. Press the UP/Down keys to display the communication parameter group "PG10".
3. Press the SET key to display the communication item to be set.  
Every time the SET key is depressed, setting item switches.
4. Press the UP/Down keys and set the communication setting.
5. Turn off power of the temperature controller and turn on again to set the setting.

### ◆ Setting value

Add	0
bPS	2
bIT	0

#### **NOTE**

- Parameters to be set differ per temperature controller. Please refer to the temperature controller manual for details.

### 3.13 Setting Example 13

#### ■ Settings of GP-Pro EX

##### ◆ Communication Settings

To display the setup screen, from the [Project] menu, point to [System Settings] and select [Device/PLC].

- NOTE** • Setting value for Wait To Send differs depending on the External Device. Please refer to the manual of the External Device for more details.

##### ◆ Device Setting

To display the [Individual Device Settings] dialog box, from [Device-Specific Settings] in the [Device/PLC] window, select the external device and click [Settings] .

To connect multiple External Devices, from [Device-Specific Settings] in the [Device/PLC] window, click [Add Device] to add another External Device.



## ■ Settings of External Device

Communication setting of the external device is set with the SEL, MODE, UP and Down keys located on the front face of the temperature controller.

Please refer to the temperature controller manual for details.

### ◆ Procedure

1. Set the external device to operation STOP status.  
Press the MODE key to display "Operation execution (RUN) /STOP transfer," and press the Down key to set the mode to STOP.
2. Press the SET key to change from SV setting mode to operator setting mode.
3. Depress the SET key for 5 seconds or more to change from operator setting mode to setup mode.
4. Press the Up key to display PG24.
5. Every time the SET key is depressed, setting item switches.  
Display the item to be set, and select set contents with the Up/Down keys or the Shift key.
6. Press the SET key to set the set contents.
7. Press the MODE key to display "Operation execution (RUN)/STOP transfer," and press the Up key to set the mode to RUN.

### ◆ Setting value

Add	0
bPS	3
bIT	0
CMPS	0

---

**NOTE** • Parameters to be set differ per temperature controller. Please refer to the temperature controller manual for details.

---

### 3.14 Setting Example 14

#### ■ Settings of GP-Pro EX

##### ◆ Communication Settings

To display the setup screen, from the [Project] menu, point to [System Settings] and select [Device/PLC].

Device/PLC 1

Summary [Change Device/PLC](#)

Manufacturer  Series  Port

Text Data Mode  [Change](#)

Communication Settings

RS232C     RS422/485(2wire)     RS422/485(4wire)

Speed

Data Length  7     8

Parity  NONE     EVEN     ODD

Stop Bit  1     2

Flow Control  NONE     ER(DTR/CTS)     XON/XOFF

Timeout  (sec)

Retry

Wait To Send  (ms)

RI / VCC     RI     VCC

In the case of RS232C, you can select the 9th pin to RI (Input) or VCC (5V Power Supply). If you use the Digital's RS232C Isolation Unit, please select it to VCC.

Device-Specific Settings

Allowable Number of Devices/PLCs: 16 [Add Device](#)

No.	Device Name	Settings	Add Indirect Device
1	PLC1	Series=SRV, Device Address=0	<input type="button" value="+"/>

**NOTE** • Setting value for Wait To Send differs depending on the External Device. Please refer to the manual of the External Device for more details.

##### ◆ Device Setting

To display the [Individual Device Settings] dialog box, from [Device-Specific Settings] in the [Device/PLC] window, select the external device and click [Settings] .

To connect multiple External Devices, from [Device-Specific Settings] in the [Device/PLC] window, click [Add Device] to add another External Device.

Individual Device Settings

PLC1

Series

Device Address

## ■ Settings of External Device

Communication setting of the external device is set with the rotary switch on the front face of the temperature controller and the dip switch in the temperature controller.

Please refer to the temperature controller manual for details.

### ◆ Procedure

1. Set module address with the rotary switch on the front face of the temperature controller.
2. Set communication speed and data bit construction with the dip switch on the side of the temperature controller.

### ◆ Setting value

Rotary switch

Upper Digit Setting	0
Lower Digit Setting	0

Dip switch

Dip switch	Setting	Description
SW1	ON	Communication speed
SW2	OFF	
SW3	ON	Data bit construction
SW4	OFF	
SW5	OFF	
SW6	OFF	Protocol construction
SW7	OFF	Fixed
SW8	OFF	

### 3.15 Setting Example 15

#### ■ Settings of GP-Pro EX

##### ◆ Communication Settings

To display the setup screen, from the [Project] menu, point to [System Settings] and select [Device/PLC].

- NOTE** • Setting value for Wait To Send differs depending on the External Device. Please refer to the manual of the External Device for more details.

##### ◆ Device Setting

To display the [Individual Device Settings] dialog box, from [Device-Specific Settings] in the [Device/PLC] window, select the external device and click [Settings] .

To connect multiple External Devices, from [Device-Specific Settings] in the [Device/PLC] window, click [Add Device] to add another External Device.

## ■ Settings of External Device

Communication setting of the external device is set with the rotary switch on the front face of the temperature controller and the dip switch in the temperature controller.

Please refer to the temperature controller manual for details.

### ◆ Procedure

1. Set module address with the rotary switch on the front face of the temperature controller.
2. Set communication speed and data bit construction with the dip switch on the side of the temperature controller.

### ◆ Setting value

Rotary switch

Upper Digit Setting	0
Lower Digit Setting	0

Dip switch

Dip switch	Setting	Description
SW1	ON	Communication speed
SW2	OFF	
SW3	ON	Data bit construction
SW4	OFF	
SW5	OFF	
SW6	OFF	Protocol construction
SW7	OFF	Fixed
SW8	OFF	

## 3.16 Setting Example 16

### ■ Settings of GP-Pro EX

#### ◆ Communication Settings

To display the setup screen, from the [Project] menu, point to [System Settings] and select [Device/PLC].

- NOTE** • Setting value for Wait To Send differs depending on the External Device. Please refer to the manual of the External Device for more details.

#### ◆ Device Setting

To display the [Individual Device Settings] dialog box, from [Device-Specific Settings] in the [Device/PLC] window, select the external device and click [Settings] .

To connect multiple External Devices, from [Device-Specific Settings] in the [Device/PLC] window, click [Add Device] to add another External Device.

## ■ Settings of External Device

Communication setting of the external device is set with the SET, Shift, UP and Down keys located on the front face of the temperature controller.

Please refer to the temperature controller manual for details.

### ◆ Procedure

1. While depressing the SET key, press the Shift key to change from PV/SV display mode to communication setting mode.
2. Press the SET key and select parameters.
3. Press UP/Down keys to change the setting.
4. While depressing the SET key, press Shift key to change from communication setting mode to PV/SV display mode.
5. Turn off power to the temperature controller and turn on again to set the setting.

### ◆ Setting value

Add	0
bPS	960
bIT	8n1

**NOTE**

- Parameters to be set differ per temperature controller. Please refer to the temperature controller manual for details.

### 3.17 Setting Example 17

#### ■ Settings of GP-Pro EX

##### ◆ Communication Settings

To display the setup screen, from the [Project] menu, point to [System Settings] and select [Device/PLC].

#### NOTE

- Setting value for Wait To Send differs depending on the External Device. Please refer to the manual of the External Device for more details.

##### ◆ Device Setting

To display the [Individual Device Settings] dialog box, from [Device-Specific Settings] in the [Device/PLC] window, select the external device and click [Settings] .

To connect multiple External Devices, from [Device-Specific Settings] in the [Device/PLC] window, click [Add Device] to add another External Device.



## ■ Settings of External Device

Communication setting of the external device is set with the SET, Shift, UP and Down keys located on the front face of the temperature controller.

Please refer to the temperature controller manual for details.

### ◆ Procedure

1. While depressing the SET key, press the Shift key to change from PV/SV display mode to communication setting mode.
2. Press the SET key and select parameters.
3. Press UP/Down keys to change the setting.
4. While depressing the SET key, press Shift key to change from communication setting mode to PV/SV display mode.
5. Turn off power to the temperature controller and turn on again to set the setting.

### ◆ Setting value

Add	0
bPS	960
bIT	8n1

**NOTE**

- Parameters to be set differ per temperature controller. Please refer to the temperature controller manual for details.

## 3.18 Setting Example 18

### ■ Settings of GP-Pro EX

#### ◆ Communication Settings

To display the setup screen, from the [Project] menu, point to [System Settings] and select [Device/PLC].

- NOTE** • Setting value for Wait To Send differs depending on the External Device. Please refer to the manual of the External Device for more details.

#### ◆ Device Setting

To display the [Individual Device Settings] dialog box, from [Device-Specific Settings] in the [Device/PLC] window, select the external device and click [Settings] .

To connect multiple External Devices, from [Device-Specific Settings] in the [Device/PLC] window, click [Add Device] to add another External Device.

## ■ Settings of External Device

Communication setting of the external device is set with the SEL, MONI/MODE, UP and Down keys located on the front face of the temperature controller.

Please refer to the temperature controller manual for details.

### ◆ Procedure

1. Depress the SEL key for 2 seconds to change from PV display mode to engineer setting mode.  
Parameter group is displayed.
2. Press the Up/Down keys to display the parameter group, "PG8."
3. Press the SEL key to display the setting item. Every time the SEL key is depressed, setting item switches.
4. Press the Up/Down keys to select the setting value, and press the SEL key.
5. Press the Monitor/Mode key to switch to the PV display mode.
6. Press the Monitor/Mode key and the SEL key at the same time to change from PV display mode to SETUP setting mode.
7. Press the SEL key several times to display Add.
8. Press the Up/Down keys to input set value, and press the SEL key to set the input value.
9. Press the Monitor/Mode keys to switch to the PV display mode.
10. Turn off power of external device off, and turn it on again.

### ◆ Setting value

Engineer setting mode

bPS	3
bIT	0

SETUP setting mode

Add	0
-----	---

#### **NOTE**

- Parameters to be set differ per temperature controller. Please refer to the temperature controller manual for details.

### 3.19 Setting Example 19

#### ■ Settings of GP-Pro EX

##### ◆ Communication Settings

To display the setup screen, from the [Project] menu, point to [System Settings] and select [Device/PLC].

**NOTE** • Setting value for Wait To Send differs depending on the External Device. Please refer to the manual of the External Device for more details.

##### ◆ Device Setting

To display the [Individual Device Settings] dialog box, from [Device-Specific Settings] in the [Device/PLC] window, select the external device and click [Settings] .

To connect multiple External Devices, from [Device-Specific Settings] in the [Device/PLC] window, click [Add Device] to add another External Device.

## ■ Settings of External Device

Communication setting of the external device is set with the SEL, MONI/MODE, UP and Down keys located on the front face of the temperature controller.

Please refer to the temperature controller manual for details.

### ◆ Procedure

1. Depress the SEL key for 2 seconds to change from PV display mode to engineer setting mode.  
Parameter group is displayed.
2. Press the Up/Down keys to display the parameter group, "PG8."
3. Press the SEL key to display the setting item. Every time the SEL key is depressed, setting item switches.
4. Press the Up/Down keys to select the setting value, and press the SEL key.
5. Press the Monitor/Mode key to switch to the PV display mode.
6. Press the Monitor/Mode key and the SEL key at the same time to change from PV display mode to SETUP setting mode.
7. Press the SEL key several times to display Add.
8. Press the Up/Down keys to input set value, and press the SEL key to set the input value.
9. Press the Monitor/Mode keys to switch to the PV display mode.
10. Turn off power of external device off, and turn it on again.

### ◆ Setting value

Engineer setting mode

bPS	3
bIT	0

SETUP setting mode

Add	0
-----	---

#### **NOTE**

- Parameters to be set differ per temperature controller. Please refer to the temperature controller manual for details.

## 3.20 Setting Example 20

### ■ Settings of GP-Pro EX

#### ◆ Communication Settings

To display the setup screen, from the [Project] menu, point to [System Settings] and select [Device/PLC].

#### NOTE

- Setting value for Wait To Send differs depending on the External Device. Please refer to the manual of the External Device for more details.

#### ◆ Device Setting

To display the [Individual Device Settings] dialog box, from [Device-Specific Settings] in the [Device/PLC] window, select the external device and click [Settings] .

To connect multiple External Devices, from [Device-Specific Settings] in the [Device/PLC] window, click [Add Device] to add another External Device.

## ■ Settings of External Device

Communication setting of the external device is set with the rotary switch on the front face of the temperature controller and the dip switch in the temperature controller.

Please refer to the temperature controller manual for details.

### ◆ Procedure

1. Unit address is set with the rotary switch on the front face of the temperature controller.
2. Remove the temperature controller from the mother block, and set the communication speed and data construction with the dip switch in the temperature controller.

### ◆ Setting value

Rotary switch

Upper Digit Setting	0
Lower Digit Setting	0

Dip switch

Dip switch	Setting	Description
SW1	OFF	Data construction
SW2	OFF	
SW3	ON	Communication speed
SW4	OFF	

## 3.21 Setting Example 21

### ■ Settings of GP-Pro EX

#### ◆ Communication Settings

To display the setup screen, from the [Project] menu, point to [System Settings] and select [Device/PLC].

**NOTE** • Setting value for Wait To Send differs depending on the External Device. Please refer to the manual of the External Device for more details.

#### ◆ Device Setting

To display the [Individual Device Settings] dialog box, from [Device-Specific Settings] in the [Device/PLC] window, select the external device and click [Settings] .

To connect multiple External Devices, from [Device-Specific Settings] in the [Device/PLC] window, click [Add Device] to add another External Device.



## ■ Settings of External Device

Communication setting of the external device is set with the rotary switch on the front face of the temperature controller and the dip switch in the temperature controller.

Please refer to the temperature controller manual for details.

### ◆ Procedure

1. Unit address is set with the rotary switch on the front face of the temperature controller.
2. Remove the temperature controller from the mother block, and set the communication speed and data construction with the dip switch in the temperature controller.

### ◆ Setting value

Rotary switch

Upper Digit Setting	0
Lower Digit Setting	0

Dip switch

Dip switch	Setting	Description
SW1	OFF	Data construction
SW2	OFF	
SW3	ON	Communication speed
SW4	OFF	

## 3.22 Setting Example 22

### ■ Settings of GP-Pro EX

#### ◆ Communication Settings

To display the setup screen, from the [Project] menu, point to [System Settings] and select [Device/PLC].

**NOTE** • Setting value for Wait To Send differs depending on the External Device. Please refer to the manual of the External Device for more details.

#### ◆ Device Setting

To display the [Individual Device Settings] dialog box, from [Device-Specific Settings] in the [Device/PLC] window, select the external device and click [Settings] .

To connect multiple External Devices, from [Device-Specific Settings] in the [Device/PLC] window, click [Add Device] to add another External Device.

## ■ Settings of External Device

Communication setting of the external device is set with the rotary switch on the front face of the temperature controller and the dip switch in the temperature controller.

Please refer to the temperature controller manual for details.

### ◆ Procedure

1. Unit address is set with the rotary switch on the front face of the temperature controller.
2. Remove the temperature controller from the mother block, and set the communication speed and data construction with the dip switch in the temperature controller.

### ◆ Setting value

Rotary switch

Upper Digit Setting	0
Lower Digit Setting	0

Dip switch

Dip switch	Setting	Description
SW1	OFF	Data construction
SW2	OFF	
SW3	ON	Communication speed
SW4	OFF	

### 3.23 Setting Example 23

#### ■ Settings of GP-Pro EX

##### ◆ Communication Settings

To display the setup screen, from the [Project] menu, point to [System Settings] and select [Device/PLC].

Device/PLC 1

Summary [Change Device/PLC](#)

Manufacturer  Series  Port

Text Data Mode  [Change](#)

Communication Settings

SI0 Type  RS232C  RS422/485(2wire)  RS422/485(4wire)

Speed

Data Length  7  8

Parity  NONE  EVEN  ODD

Stop Bit  1  2

Flow Control  NONE  ER(DTR/CTS)  XON/XOFF

Timeout  (sec)

Retry

Wait To Send  (ms)

RI / VCC  RI  VCC

In the case of RS232C, you can select the 9th pin to RI (Input) or VCC (5V Power Supply). If you use the Digital's RS232C Isolation Unit, please select it to VCC.

Device-Specific Settings

Allowable Number of Devices/PLCs: 16 [Add Device](#)

No.	Device Name	Settings
1	PLC1	Series=REX-F, Device Address=0

#### NOTE

- Setting value for Wait To Send differs depending on the External Device. Please refer to the manual of the External Device for more details.

##### ◆ Device Setting

To display the [Individual Device Settings] dialog box, from [Device-Specific Settings] in the [Device/PLC] window, select the external device and click [Settings] .

To connect multiple External Devices, from [Device-Specific Settings] in the [Device/PLC] window, click [Add Device] to add another External Device.

Individual Device Settings

PLC1

Series

Device Address

## ■ Settings of External Device

Communication setting of the external device is set with the SEL, MODE, UP and Down keys located on the front face of the temperature controller.

Please refer to the temperature controller manual for details.

### ◆ Procedure

1. Set the external device to the operation STOP status.  
Press the MODE key several times to display "Operation execution (RUN) /STOP transfer," and press the Down key to set the mode to STOP.
2. Press the SET key to call up the set operator level 1.
3. Depress the SET key for 5 seconds or more to call up the set operator level 2.
4. Depress the SET key for 5 seconds or more to call up the engineer level.
5. Press the Down key several times to display PG24.
6. Press the SET key to display the set contents. Every time the SET key is depressed, item to be set switches.
7. Input the set contents with the Up/Down key, and press the SET key.
8. Press the MODE key to display "Operation execution (RUN)/STOP transfer," and press the Up key to set the mode to RUN.

### ◆ Setting value

Add	0
bPS	3
bIT	11

#### **NOTE**

- Parameters to be set differ per temperature controller. Please refer to the temperature controller manual for details.

## 3.24 Setting Example 24

### ■ Settings of GP-Pro EX

#### ◆ Communication Settings

To display the setup screen, from the [Project] menu, point to [System Settings] and select [Device/PLC].

#### NOTE

- Setting value for Wait To Send differs depending on the External Device. Please refer to the manual of the External Device for more details.

#### ◆ Device Setting

To display the [Individual Device Settings] dialog box, from [Device-Specific Settings] in the [Device/PLC] window, select the external device and click [Settings] .

To connect multiple External Devices, from [Device-Specific Settings] in the [Device/PLC] window, click [Add Device] to add another External Device.

## ■ Settings of External Device

Communication setting of the external device is set with the SEL, MODE, UP and Down keys located on the front face of the temperature controller.

Please refer to the temperature controller manual for details.

### ◆ Procedure

1. Set the external device to the operation STOP status.  
Press the MODE key several times to display "Operation execution (RUN) /STOP transfer," and press the Down key to set the mode to STOP.
2. Press the SET key to call up the set operator level 1.
3. Depress the SET key for 5 seconds or more to call up the set operator level 2.
4. Depress the SET key for 5 seconds or more to call up the engineer level.
5. Press the Down key several times to display PG24.
6. Press the SET key to display the set contents. Every time the SET key is depressed, item to be set switches.
7. Input the set contents with the Up/Down key, and press the SET key.
8. Press the MODE key to display "Operation execution (RUN)/STOP transfer," and press the Up key to set the mode to RUN.

### ◆ Setting value

Add	0
bPS	3
bIT	11

---

**NOTE** • Parameters to be set differ per temperature controller. Please refer to the temperature controller manual for details.

---

## 3.25 Setting Example 25

### ■ Settings of GP-Pro EX

#### ◆ Communication Settings

To display the setup screen, from the [Project] menu, point to [System Settings] and select [Device/PLC].

Device/PLC 1

Summary [Change Device/PLC](#)

Manufacturer  Series  Port

Text Data Mode  [Change](#)

Communication Settings

RS232C  RS422/485(2wire)  RS422/485(4wire)  
 Speed   
 Data Length  7  8  
 Parity  NONE  EVEN  ODD  
 Stop Bit  1  2  
 Flow Control  NONE  ER(DTR/CTS)  XON/XOFF  
 Timeout  (sec)  
 Retry   
 Wait To Send  (ms)

RI / VCC  RI  VCC  
In the case of RS232C, you can select the 9th pin to RI (Input or VCC (5V Power Supply). If you use the Digital's RS232C Isolation Unit, please select it to VCC.

Device-Specific Settings

Allowable Number of Devices/PLCs  [Add Device](#)

No.	Device Name	Settings
<input type="button" value="1"/>	<input type="text" value="PLC1"/>	<input type="text" value="Series=REX-F,Device Address=0"/>

#### NOTE

- Setting value for Wait To Send differs depending on the External Device. Please refer to the manual of the External Device for more details.

#### ◆ Device Setting

To display the [Individual Device Settings] dialog box, from [Device-Specific Settings] in the [Device/PLC] window, select the external device and click [Settings] .

To connect multiple External Devices, from [Device-Specific Settings] in the [Device/PLC] window, click [Add Device] to add another External Device.

Individual Device Settings

PLC1

Series

Device Address



## ■ Settings of External Device

Communication setting of the external device is set with the SEL, MODE, UP and Down keys located on the front face of the temperature controller.

Please refer to the temperature controller manual for details.

### ◆ Procedure

1. Set the external device to the operation STOP status.  
Press the MODE key several times to display "Operation execution (RUN) /STOP transfer," and press the Down key to set the mode to STOP.
2. Press the SET key to call up the set operator level 1.
3. Depress the SET key for 5 seconds or more to call up the set operator level 2.
4. Depress the SET key for 5 seconds or more to call up the engineer level.
5. Press the Down key several times to display PG24.
6. Press the SET key to display the set contents. Every time the SET key is depressed, item to be set switches.
7. Input the set contents with the Up/Down key, and press the SET key.
8. Press the MODE key to display "Operation execution (RUN)/STOP transfer," and press the Up key to set the mode to RUN.

### ◆ Setting value

Add	0
bPS	3
bIT	11

#### **NOTE**

- Parameters to be set differ per temperature controller. Please refer to the temperature controller manual for details.

## 3.26 Setting Example 26

### ■ Settings of GP-Pro EX

#### ◆ Communication Settings

To display the setup screen, from the [Project] menu, point to [System Settings] and select [Device/PLC].

**NOTE** • Setting value for Wait To Send differs depending on the External Device. Please refer to the manual of the External Device for more details.

#### ◆ Device Setting

To display the [Individual Device Settings] dialog box, from [Device-Specific Settings] in the [Device/PLC] window, select the external device and click [Settings] .

To connect multiple External Devices, from [Device-Specific Settings] in the [Device/PLC] window, click [Add Device] to add another External Device.

## ■ Settings of External Device

Communication setting of the external device is set with the MODE, PARA, >>>, UP and Down keys located on the front face of the temperature controller.

Please refer to the temperature controller manual for details.

### ◆ Procedure

1. Press the MODE key to display "Operation execution (RUN)/STOP transfer."  
Press the >>> key to stop operation.
2. Press PARA key to display "Setting (PARA) screen."  
Press the Up/Down keys, select PARA GROUP 24, and press the PARA key.
3. Every time the PARA Key is depressed, setting item switches.  
Display the item to be set, and select the set contents with the Up/Down keys.
4. After setting, press the MODE key to display "Operation execution (RUN)/STOP screen."  
Press the >>> key to put the operation into action.

### ◆ Setting value

Bit Format	P (Parity): n DT (Data Bit): 8 SP (Stop bit): 1
Device Address	0
Speed	9600

#### NOTE

- Parameters to be set differ per temperature controller. Please refer to the temperature controller manual for details.

## 3.27 Setting Example 27

### ■ Settings of GP-Pro EX

#### ◆ Communication Settings

To display the setup screen, from the [Project] menu, point to [System Settings] and select [Device/PLC].

**NOTE** • Setting value for Wait To Send differs depending on the External Device. Please refer to the manual of the External Device for more details.

#### ◆ Device Setting

To display the [Individual Device Settings] dialog box, from [Device-Specific Settings] in the [Device/PLC] window, select the external device and click [Settings] .

To connect multiple External Devices, from [Device-Specific Settings] in the [Device/PLC] window, click [Add Device] to add another External Device.

## ■ Settings of External Device

Communication setting of the external device is set with the MODE, PARA, >>>, UP and Down keys located on the front face of the temperature controller.

Please refer to the temperature controller manual for details.

### ◆ Procedure

1. Press the MODE key to display "Operation execution (RUN)/STOP transfer."  
Press the >>> key to stop operation.
2. Press PARA key to display "Setting (PARA) screen."  
Press the Up/Down keys, select PARA GROUP 24, and press the PARA key.
3. Every time the PARA Key is depressed, setting item switches.  
Display the item to be set, and select the set contents with the Up/Down keys.
4. After setting, press the MODE key to display "Operation execution (RUN)/STOP screen."  
Press the >>> key to put the operation into action.

### ◆ Setting value

Bit Format	P (Parity): n DT (Data Bit): 8 SP (Stop bit): 1
Device Address	0
Speed	9600

#### NOTE

- Parameters to be set differ per temperature controller. Please refer to the temperature controller manual for details.

## 3.28 Setting Example 28

### ■ Settings of GP-Pro EX

#### ◆ Communication Settings

To display the setup screen, from the [Project] menu, point to [System Settings] and select [Device/PLC].

Device/PLC 1

Summary [Change Device/PLC](#)

Manufacturer  Series  Port

Text Data Mode  [Change](#)

Communication Settings

SI0 Type  RS232C  RS422/485(2wire)  RS422/485(4wire)

Speed

Data Length  7  8

Parity  NONE  EVEN  ODD

Stop Bit  1  2

Flow Control  NONE  ER(DTR/CTS)  XON/XOFF

Timeout  (sec)

Retry

Wait To Send  (ms)

RI / VCC  RI  VCC

In the case of RS232C, you can select the 9th pin to RI (Input or VCC (5V Power Supply). If you use the Digital's RS232C Isolation Unit, please select it to VCC.

Device-Specific Settings

Allowable Number of Devices/PLCs  [Add Device](#)

No.	Device Name	Settings
<input type="button" value="1"/>	<input type="text" value="PLC1"/>	<input type="text" value="Series=REX-G9, Device Address=0"/>

#### NOTE

- Setting value for Wait To Send differs depending on the External Device. Please refer to the manual of the External Device for more details.

#### ◆ Device Setting

To display the [Individual Device Settings] dialog box, from [Device-Specific Settings] in the [Device/PLC] window, select the external device and click [Settings] .

To connect multiple External Devices, from [Device-Specific Settings] in the [Device/PLC] window, click [Add Device] to add another External Device.

Individual Device Settings

PLC1

Series

Device Address

## ■ Settings of External Device

Communication setting of the external device is set with the MODE, PARA, >>>, UP and Down keys located on the front face of the temperature controller.

Please refer to the temperature controller manual for details.

### ◆ Procedure

1. Press the MODE key to display "Operation execution (RUN)/STOP transfer."  
Press the >>> key to stop operation.
2. Press PARA key to display "Setting (PARA) screen."  
Press the Up/Down keys, select PARA GROUP 24, and press the PARA key.
3. Every time the PARA Key is depressed, setting item switches.  
Display the item to be set, and select the set contents with the Up/Down keys.
4. After setting, press the MODE key to display "Operation execution (RUN)/STOP screen."  
Press the >>> key to put the operation into action.

### ◆ Setting value

Bit Format	P (Parity): n DT (Data Bit): 8 SP (Stop bit): 1
Device Address	0
Speed	9600

#### NOTE

- Parameters to be set differ per temperature controller. Please refer to the temperature controller manual for details.

## 3.29 Setting Example 29

### ■ Settings of GP-Pro EX

#### ◆ Communication Settings

To display the setup screen, from the [Project] menu, point to [System Settings] and select [Device/PLC].

Device/PLC 1

Summary [Change Device/PLC](#)

Manufacturer  Series  Port

Text Data Mode  [Change](#)

Communication Settings

RS232C   
  RS422/485(2wire)   
  RS422/485(4wire)

Speed

Data Length  7     8

Parity  NONE     EVEN     ODD

Stop Bit  1     2

Flow Control  NONE     ER(DTR/CTS)     XON/XOFF

Timeout  (sec)

Retry

Wait To Send  (ms)

RI / VCC   
  RI   
  VCC

In the case of RS232C, you can select the 9th pin to RI (Input) or VCC (5V Power Supply). If you use the Digital's RS232C Isolation Unit, please select it to VCC.

Device-Specific Settings

Allowable Number of Devices/PLCs  [Add Device](#)

No.	Device Name	Settings
<input type="button" value="1"/>	<input type="text" value="PLC1"/>	<input type="text" value="Series=REX-P300, Device Address=0"/>

**NOTE** • Setting value for Wait To Send differs depending on the External Device. Please refer to the manual of the External Device for more details.

#### ◆ Device Setting

To display the [Individual Device Settings] dialog box, from [Device-Specific Settings] in the [Device/PLC] window, select the external device and click [Settings] .

To connect multiple External Devices, from [Device-Specific Settings] in the [Device/PLC] window, click [Add Device] to add another External Device.

Individual Device Settings

PLC1

Series

Device Address



## ■ Settings of External Device

Communication setting of the external device is set with the SET, MODE, UP and Down keys located on the front face of the temperature controller.

Please refer to the temperature controller manual for details.

### ◆ Procedure

1. Press the SET key for 2 seconds to change from PV display mode to engineer setting mode.  
Parameter group is displayed.
2. Press the Up/Down keys to display the parameter group, "PG60."
3. Press the SET Key to display setting item. Every time the SET Key is depressed, item to be set switches.
4. Press the Up/Down keys to select set value, and press the SET Key.
5. Press the Reset key to reset the external device.
6. Press the Monitor/Mode key and the SET key at the same time to move to SETUP setting mode.
7. Press the SET key several times to display Add.
8. Press the Up/Down keys to select set value, and press the SET key.
9. Press the RUN/HOLD key to move to operation monitor mode.

### ◆ Setting value

Engineer setting mode

bPS	2
bIT	0

SETUP setting mode

Add	0
-----	---

#### **NOTE**

- Parameters to be set differ per temperature controller. Please refer to the temperature controller manual for details.

### 3.30 Setting Example 30

#### ■ Settings of GP-Pro EX

##### ◆ Communication Settings

To display the setup screen, from the [Project] menu, point to [System Settings] and select [Device/PLC].

Device/PLC 1

Summary [Change Device/PLC](#)

Manufacturer  Series  Port

Text Data Mode  [Change](#)

Communication Settings

SI0 Type  RS232C  RS422/485(2wire)  RS422/485(4wire)

Speed

Data Length  7  8

Parity  NONE  EVEN  ODD

Stop Bit  1  2

Flow Control  NONE  ER(DTR/CTS)  XON/XOFF

Timeout  (sec)

Retry

Wait To Send  (ms)

RI / VCC  RI  VCC

In the case of RS232C, you can select the 9th pin to RI (Input) or VCC (5V Power Supply). If you use the Digital's RS232C Isolation Unit, please select it to VCC.

Device-Specific Settings

Allowable Number of Devices/PLCs 16 [Add Device](#)

No.	Device Name	Settings
<input type="button" value="1"/>	<input type="text" value="PLC1"/>	<input type="text" value="Series=REX-P300,Device Address=0"/>

**NOTE** • Setting value for Wait To Send differs depending on the External Device. Please refer to the manual of the External Device for more details.

##### ◆ Device Setting

To display the [Individual Device Settings] dialog box, from [Device-Specific Settings] in the [Device/PLC] window, select the external device and click [Settings] .

To connect multiple External Devices, from [Device-Specific Settings] in the [Device/PLC] window, click [Add Device] to add another External Device.

Individual Device Settings

PLC1

Series

Device Address

## ■ Settings of External Device

Communication setting of the external device is set with the SET, MODE, UP and Down keys located on the front face of the temperature controller.

Please refer to the temperature controller manual for details.

### ◆ Procedure

1. Press the SET key for 2 seconds to change from PV display mode to engineer setting mode.  
Parameter group is displayed.
2. Press the Up/Down keys to display the parameter group, "PG60."
3. Press the SET Key to display setting item. Every time the SET Key is depressed, item to be set switches.
4. Press the Up/Down keys to select set value, and press the SET Key.
5. Press the Reset key to reset the external device.
6. Press the Monitor/Mode key and the SET key at the same time to move to SETUP setting mode.
7. Press the SET key several times to display Add.
8. Press the Up/Down keys to select set value, and press the SET key.
9. Press the RUN/HOLD key to move to operation monitor mode.

### ◆ Setting value

Engineer setting mode

bPS	2
bIT	0

SETUP setting mode

Add	0
-----	---

#### **NOTE**

- Parameters to be set differ per temperature controller. Please refer to the temperature controller manual for details.

### 3.31 Setting Example 31

#### ■ Settings of GP-Pro EX

##### ◆ Communication Settings

To display the setup screen, from the [Project] menu, point to [System Settings] and select [Device/PLC].

#### NOTE

- Setting value for Wait To Send differs depending on the External Device. Please refer to the manual of the External Device for more details.

##### ◆ Device Setting

To display the [Individual Device Settings] dialog box, from [Device-Specific Settings] in the [Device/PLC] window, select the external device and click [Settings] .

To connect multiple External Devices, from [Device-Specific Settings] in the [Device/PLC] window, click [Add Device] to add another External Device.

## ■ Settings of External Device

Communication setting of the external device is set with the SET, MODE, UP and Down keys located on the front face of the temperature controller.

Please refer to the temperature controller manual for details.

### ◆ Procedure

1. Press the SET key for 2 seconds to change from PV display mode to engineer setting mode.  
Parameter group is displayed.
2. Press the Up/Down keys to display the parameter group, "PG60."
3. Press the SET Key to display setting item. Every time the SET Key is depressed, item to be set switches.
4. Press the Up/Down keys to select set value, and press the SET Key.
5. Press the Reset key to reset the external device.
6. Press the Monitor/Mode key and the SET key at the same time to move to SETUP setting mode.
7. Press the SET key several times to display Add.
8. Press the Up/Down keys to select set value, and press the SET key.
9. Press the RUN/HOLD key to move to operation monitor mode.

### ◆ Setting value

Engineer setting mode

bPS	2
bIT	0

SETUP setting mode

Add	0
-----	---

#### **NOTE**

- Parameters to be set differ per temperature controller. Please refer to the temperature controller manual for details.

## 3.32 Setting Example 32

### ■ Settings of GP-Pro EX

#### ◆ Communication Settings

To display the setup screen, from the [Project] menu, point to [System Settings] and select [Device/PLC].

#### NOTE

- Setting value for Wait To Send differs depending on the External Device. Please refer to the manual of the External Device for more details.

#### ◆ Device Setting

To display the [Individual Device Settings] dialog box, from [Device-Specific Settings] in the [Device/PLC] window, select the external device and click [Settings] .

To connect multiple External Devices, from [Device-Specific Settings] in the [Device/PLC] window, click [Add Device] to add another External Device.

## ■ Settings of External Device

Communication setting of the external device is set with the SET, UP and Down keys located on the front face of the temperature controller.

Please refer to the temperature controller manual for details.

### ◆ Procedure

1. While lifting up the stopper located at the lower section of the external device with a finger, pull and remove it from the case.
2. Turn on the internal switch A at upper external device and put it back in the case.
3. Press the SET key to display the item to be set, and select the set contents with the Up/Down keys. Stop bit, data bit, and parity bit are displayed in a 3 digit character string at the setting item, bIT, so touch each one's digit, ten's digit, and hundred's digit on the SV indicator, and select the set contents with the Up/Down keys.
4. Press the SET key to set the set contents.
5. Remove the external device from the case, turn OFF the internal switch A mentioned in 2 above, and return it to the case.

### ◆ Setting value

bPS	4800
bIT	072
Add	0

#### **NOTE**

- Parameters to be set differ per temperature controller. Please refer to the temperature controller manual for details.

### 3.33 Setting Example 33

#### ■ Settings of GP-Pro EX

##### ◆ Communication Settings

To display the setup screen, from the [Project] menu, point to [System Settings] and select [Device/PLC].

Device/PLC 1

Summary [Change Device/PLC](#)

Manufacturer  Series  Port

Text Data Mode  [Change](#)

Communication Settings

SI0 Type  RS232C  RS422/485(2wire)  RS422/485(4wire)

Speed

Data Length  7  8

Parity  NONE  EVEN  ODD

Stop Bit  1  2

Flow Control  NONE  ER(DTR/CTS)  XON/XOFF

Timeout  (sec)

Retry

Wait To Send  (ms)

RI / VCC  RI  VCC

In the case of RS232C, you can select the 9th pin to RI (Input) or VCC (5V Power Supply). If you use the Digital's RS232C Isolation Unit, please select it to VCC.

Device-Specific Settings

Allowable Number of Devices/PLCs  [Add Device](#)

No.	Device Name	Settings
<input type="button" value="1"/>	<input type="text" value="PLC1"/>	<input type="text" value="Series=REX-P250, Device Address=0"/>

**NOTE** • Setting value for Wait To Send differs depending on the External Device. Please refer to the manual of the External Device for more details.

##### ◆ Device Setting

To display the [Individual Device Settings] dialog box, from [Device-Specific Settings] in the [Device/PLC] window, select the external device and click [Settings] .

To connect multiple External Devices, from [Device-Specific Settings] in the [Device/PLC] window, click [Add Device] to add another External Device.

Individual Device Settings

PLC1

Series

Device Address



## ■ Settings of External Device

Communication setting of the external device is set with the SET, UP and Down keys located on the front face of the temperature controller.

Please refer to the temperature controller manual for details.

### ◆ Procedure

1. While lifting up the stopper located at the lower section of the external device with a finger, pull and remove it from the case.
2. Turn on the internal switch A at upper external device and put it back in the case.
3. Press the SET key to display the item to be set, and select the set contents with the Up/Down keys. Stop bit, data bit, and parity bit are displayed in a 3 digit character string at the setting item, bIT, so touch each one's digit, ten's digit, and hundred's digit on the SV indicator, and select the set contents with the Up/Down keys.
4. Press the SET key to set the set contents.
5. Remove the external device form the case, turn OFF the internal switch A mentioned in 2 above, and return it to the case.

### ◆ Setting value

bPS	4800
bIT	072
Add	0

#### NOTE

- Parameters to be set differ per temperature controller. Please refer to the temperature controller manual for details.

### 3.34 Setting Example 34

#### ■ Settings of GP-Pro EX

##### ◆ Communication Settings

To display the setup screen, from the [Project] menu, point to [System Settings] and select [Device/PLC].

**NOTE** • Setting value for Wait To Send differs depending on the External Device. Please refer to the manual of the External Device for more details.

##### ◆ Device Setting

To display the [Individual Device Settings] dialog box, from [Device-Specific Settings] in the [Device/PLC] window, select the external device and click [Settings] .

To connect multiple External Devices, from [Device-Specific Settings] in the [Device/PLC] window, click [Add Device] to add another External Device.

## ■ Settings of External Device

Communication setting of the external device is set with the SEL, MODE, UP and Down keys located on the front face of the temperature controller.

Please refer to the temperature controller manual for details.

### ◆ Procedure

1. Depress the SEL key for 2 seconds to change from PV display mode to engineer setting mode.  
Parameter group is displayed.
2. Press the Up/Down keys to display the parameter group, "PG9."
3. Press the SEL key to display the setting item. Every time the SEL key is depressed, setting item switches.
4. Press the Up/Down keys to display the setting value.
5. Press the Up/Down keys to select the setting value, and press the SEL key.
6. Press the Monitor/Mode key to switch to the PV display mode.
7. Press the Monitor/Mode key and the SEL key at the same time to change from PV display mode to SETUP setting mode.
8. Press the SEL key several times to display Add.
9. Press the Up/Down keys to display the setting value.
10. Press the Up/Down keys to display the setting value.
11. Press the Monitor/Mode keys to switch to the PV display mode.

### ◆ Setting value

Engineer setting mode

bPS	3
bIT	0

SETUP setting mode

Add	0
-----	---

---

**NOTE** • Parameters to be set differ per temperature controller. Please refer to the temperature controller manual for details.

---

### 3.35 Setting Example 35

#### ■ Settings of GP-Pro EX

##### ◆ Communication Settings

To display the setup screen, from the [Project] menu, point to [System Settings] and select [Device/PLC].

**NOTE** • Setting value for Wait To Send differs depending on the External Device. Please refer to the manual of the External Device for more details.

##### ◆ Device Setting

To display the [Individual Device Settings] dialog box, from [Device-Specific Settings] in the [Device/PLC] window, select the external device and click [Settings] .

To connect multiple External Devices, from [Device-Specific Settings] in the [Device/PLC] window, click [Add Device] to add another External Device.

## ■ Settings of External Device

Communication setting of the external device is set with the SEL, MODE, UP and Down keys located on the front face of the temperature controller.

Please refer to the temperature controller manual for details.

### ◆ Procedure

1. Depress the SEL key for 2 seconds to change from PV display mode to engineer setting mode.  
Parameter group is displayed.
2. Press the Up/Down keys to display the parameter group, "PG9."
3. Press the SEL key to display the setting item. Every time the SEL key is depressed, setting item switches.
4. Press the Up/Down keys to display the setting value.
5. Press the Up/Down keys to select the setting value, and press the SEL key.
6. Press the Monitor/Mode key to switch to the PV display mode.
7. Press the Monitor/Mode key and the SEL key at the same time to change from PV display mode to SETUP setting mode.
8. Press the SEL key several times to display Add.
9. Press the Up/Down keys to display the setting value.
10. Press the Up/Down keys to display the setting value.
11. Press the Monitor/Mode keys to switch to the PV display mode.

### ◆ Setting value

Engineer setting mode

bPS	3
bIT	0

SETUP setting mode

Add	0
-----	---

#### **NOTE**

- Parameters to be set differ per temperature controller. Please refer to the temperature controller manual for details.

### 3.36 Setting Example 36

#### ■ Settings of GP-Pro EX

##### ◆ Communication Settings

To display the setup screen, from the [Project] menu, point to [System Settings] and select [Device/PLC].

#### NOTE

- Setting value for Wait To Send differs depending on the External Device. Please refer to the manual of the External Device for more details.

##### ◆ Device Setting

To display the [Individual Device Settings] dialog box, from [Device-Specific Settings] in the [Device/PLC] window, select the external device and click [Settings] .

To connect multiple External Devices, from [Device-Specific Settings] in the [Device/PLC] window, click [Add Device] to add another External Device.

## ■ Settings of External Device

Communication setting of the external device is set with the SEL, MODE, UP and Down keys located on the front face of the temperature controller.

Please refer to the temperature controller manual for details.

### ◆ Procedure

1. Depress the SEL key for 2 seconds to change from PV display mode to engineer setting mode.  
Parameter group is displayed.
2. Press the Up/Down keys to display the parameter group, "PG6."
3. Press the SEL key to display the setting item. Every time the SEL key is depressed, setting item switches.
4. Press the Up/Down keys to display the setting value.
5. Press the Up/Down keys to select the setting value, and press the SEL key.
6. Press the Monitor/Mode key to switch to the PV display mode.
7. Press the Monitor/Mode key and the SEL key at the same time to change from PV display mode to SETUP setting mode.
8. Press the SEL key several times to display Add.
9. Press the Up/Down keys to display the setting value.
10. Press the Up/Down keys to display the setting value.
11. Press the Monitor/Mode keys to switch to the PV display mode.

### ◆ Setting value

Engineer setting mode

bPS	3
bIT	0

SETUP setting mode

Add	0
-----	---

#### **NOTE**

- Parameters to be set differ per temperature controller. Please refer to the temperature controller manual for details.

### 3.37 Setting Example 37

#### ■ Settings of GP-Pro EX

##### ◆ Communication Settings

To display the setup screen, from the [Project] menu, point to [System Settings] and select [Device/PLC].

**NOTE** • Setting value for Wait To Send differs depending on the External Device. Please refer to the manual of the External Device for more details.

##### ◆ Device Setting

To display the [Individual Device Settings] dialog box, from [Device-Specific Settings] in the [Device/PLC] window, select the external device and click [Settings] .

To connect multiple External Devices, from [Device-Specific Settings] in the [Device/PLC] window, click [Add Device] to add another External Device.



## ■ Settings of External Device

Communication setting of the external device is set with the SEL, MODE, UP and Down keys located on the front face of the temperature controller.

Please refer to the temperature controller manual for details.

### ◆ Procedure

1. Depress the SEL key for 2 seconds to change from PV display mode to engineer setting mode.  
Parameter group is displayed.
2. Press the Up/Down keys to display the parameter group, "PG9."
3. Press the SEL key to display the setting item. Every time the SEL key is depressed, setting item switches.
4. Press the Up/Down keys to display the setting value.
5. Press the Up/Down keys to select the setting value, and press the SEL key.
6. Press the Monitor/Mode key to switch to the PV display mode.
7. Press the Monitor/Mode key and the SEL key at the same time to change from PV display mode to SETUP setting mode.
8. Press the SEL key several times to display Add.
9. Press the Up/Down keys to display the setting value.
10. Press the Up/Down keys to display the setting value.
11. Press the Monitor/Mode keys to switch to the PV display mode.

### ◆ Setting value

Engineer setting mode

bPS	3
bIT	0

SETUP setting mode

Add	0
-----	---

#### **NOTE**

- Parameters to be set differ per temperature controller. Please refer to the temperature controller manual for details.

### 3.38 Setting Example 38

#### ■ Settings of GP-Pro EX

##### ◆ Communication Settings

To display the setup screen, from the [Project] menu, point to [System Settings] and select [Device/PLC].

#### NOTE

- Setting value for Wait To Send differs depending on the External Device. Please refer to the manual of the External Device for more details.

##### ◆ Device Setting

To display the [Individual Device Settings] dialog box, from [Device-Specific Settings] in the [Device/PLC] window, select the external device and click [Settings] .

To connect multiple External Devices, from [Device-Specific Settings] in the [Device/PLC] window, click [Add Device] to add another External Device.

## ■ Settings of External Device

Communication setting of the external device is set with the slave address setting switch on the front face of the temperature controller and the dip switch in the temperature controller.

Please refer to the temperature controller manual for details.

### ◆ Procedure

1. Set slave address for the host link with the slave address setting switch on the front face of the temperature controller.
2. Remove the temperature controller from the mother block and set communication speed and data construction with the dip switch in the temperature controller.

### ◆ Setting value

Slave address setting switch

Upper Digit Setting	0
Lower Digit Setting	0

Dip switch

Dip switch	Setting	Discription
1	ON	Data construction
2	ON	
3	ON	Communication speed
4	OFF	

#### **NOTE**

- Parameters to be set differ per temperature controller. Please refer to the temperature controller manual for details.

### 3.39 Setting Example 39

#### ■ Settings of GP-Pro EX

##### ◆ Communication Settings

To display the setup screen, from the [Project] menu, point to [System Settings] and select [Device/PLC].

**NOTE** • Setting value for Wait To Send differs depending on the External Device. Please refer to the manual of the External Device for more details.

##### ◆ Device Setting

To display the [Individual Device Settings] dialog box, from [Device-Specific Settings] in the [Device/PLC] window, select the external device and click [Settings] .

To connect multiple External Devices, from [Device-Specific Settings] in the [Device/PLC] window, click [Add Device] to add another External Device.

## ■ Settings of External Device

Communication setting of the external device is set with the slave address setting switch on the front face of the temperature controller and the dip switch in the temperature controller.

Please refer to the temperature controller manual for details.

### ◆ Procedure

1. Set slave address for the host link with the slave address setting switch on the front face of the temperature controller.
2. Remove the temperature controller from the mother block and set communication speed and data construction with the dip switch in the temperature controller.

### ◆ Setting value

Slave address setting switch

Upper Digit Setting	0
Lower Digit Setting	0

Dip switch

Dip switch	Setting	Discription
1	ON	Data construction
2	ON	
3	ON	Communication speed
4	OFF	

#### **NOTE**

- Parameters to be set differ per temperature controller. Please refer to the temperature controller manual for details.

### 3.40 Setting Example 40

#### ■ Settings of GP-Pro EX

##### ◆ Communication Settings

To display the setup screen, from the [Project] menu, point to [System Settings] and select [Device/PLC].

Device/PLC 1

Summary [Change Device/PLC](#)

Manufacturer  Series  Port

Text Data Mode  [Change](#)

Communication Settings

SID Type  RS232C  RS422/485(2wire)  RS422/485(4wire)

Speed

Data Length  7  8

Parity  NONE  EVEN  ODD

Stop Bit  1  2

Flow Control  NONE  ER(DTR/CTS)  XON/XOFF

Timeout  (sec)

Retry

Wait To Send  (ms)

RI / VCC  RI  VCC

In the case of RS232C, you can select the 9th pin to RI (Input) or VCC (5V Power Supply). If you use the Digital's RS232C Isolation Unit, please select it to VCC.

Device-Specific Settings

Allowable Number of Devices/PLCs  [Add Device](#)

No.	Device Name	Settings	Add Indirect Device
<input type="button" value="1"/>	<input type="text" value="PLC1"/>	<input type="text" value="Series=SRZ(Z-TIO),Device Address=0"/>	<input type="button" value="+"/>

#### NOTE

- Setting value for Wait To Send differs depending on the External Device. Please refer to the manual of the External Device for more details.

### ◆ Device Setting

To display the [Individual Device Settings] dialog box, from [Device-Specific Settings] in the [Device/PLC] window, select the external device and click [Settings] .

To connect multiple External Devices, from [Device-Specific Settings] in the [Device/PLC] window, click [Add Device] to add another External Device.



### ■ Settings of External Device

Use the unit address setting switch on the front of the Temperature Controller and the DIP switch on the side of the Temperature Controller for communication settings of the External Device.

Please refer to the manual of the Temperature Controller for more details.

### ◆ Procedure

1. Use the unit address setting switch on the front of the Temperature Controller to set the slave address.
2. Use the DIP switch on the side of the Temperature Controller to set the speed, data bit configuration, and communication protocol.
3. After completing the settings, turn ON the Temperature Controller again.

### ◆ Setting Value

Unit address setting switch

Slave address setting	0
-----------------------	---

DIP Switch

SW	Settings	Description
1	OFF	Speed: 19200 bps
2	ON	
3	OFF	Data bit configuration: Data length 8 bits, no parity, stop 1 bit
4	OFF	
5	ON	
6	OFF	Communication protocol: RKC communication
7	OFF	Fixed
8	OFF	Fixed

**NOTE** • Parameters to be set vary depending on the Temperature Controller. Please refer to the manual of the Temperature Controller for more details.

### 3.41 Setting Example 41

#### ■ Settings of GP-Pro EX

##### ◆ Communication Settings

To display the setup screen, from the [Project] menu, point to [System Settings] and select [Device/PLC].

Device/PLC 1

Summary [Change Device/PLC](#)

Manufacturer  Series  Port

Text Data Mode  [Change](#)

Communication Settings

SIO Type  RS232C  RS422/485(2wire)  RS422/485(4wire)

Speed

Data Length  7  8

Parity  NONE  EVEN  ODD

Stop Bit  1  2

Flow Control  NONE  ER(DTR/CTS)  XON/XOFF

Timeout  (sec)

Retry

Wait To Send  (ms)

RI / VCC  RI  VCC

In the case of RS232C, you can select the 9th pin to RI (Input) or VCC (5V Power Supply). If you use the Digital's RS232C Isolation Unit, please select it to VCC.

Device-Specific Settings

Allowable Number of Devices/PLCs 16 [Add Device](#)

No.	Device Name	Settings
1	PLC1	Series=SRZ(Z-DIO),Device Address=0

- NOTE** • Setting value for Wait To Send differs depending on the External Device. Please refer to the manual of the External Device for more details.



### ◆ Device Setting

To display the [Individual Device Settings] dialog box, from [Device-Specific Settings] in the [Device/PLC] window, select the external device and click [Settings] .

To connect multiple External Devices, from [Device-Specific Settings] in the [Device/PLC] window, click [Add Device] to add another External Device.



### ■ Settings of External Device

Use the unit address setting switch on the front of the Temperature Controller and the DIP switch on the side of the Temperature Controller for communication settings of the External Device.

Please refer to the manual of the Temperature Controller for more details.

### ◆ Procedure

1. Use the unit address setting switch on the front of the Temperature Controller to set the slave address.  
The number added 16 to the set value becomes the slave address.
2. Use the DIP switch on the side of the Temperature Controller to set the speed, data bit configuration, and communication protocol.
3. After completing the settings, turn ON the Temperature Controller again.

### ◆ Setting Value

Unit address setting switch

Slave address setting	0
-----------------------	---

DIP Switch

SW	Settings	Description
1	OFF	Speed: 19200 bps
2	ON	
3	OFF	Data bit configuration: Data length 8 bits, no parity, stop 1 bit
4	OFF	
5	ON	
6	OFF	Communication protocol: RKC communication
7	OFF	Fixed
8	OFF	Fixed

**NOTE** • Parameters to be set vary depending on the Temperature Controller. Please refer to the manual of the Temperature Controller for more details.

## 3.42 Setting Example 42

### ■ Settings of GP-Pro EX

#### ◆ Communication Settings

To display the setup screen, from the [Project] menu, point to [System Settings] and select [Device/PLC].

Device/PLC 1

Summary [Change Device/PLC](#)

Manufacturer  Series  Port

Text Data Mode  [Change](#)

Communication Settings

SID Type  RS232C  RS422/485(2wire)  RS422/485(4wire)

Speed

Data Length  7  8

Parity  NONE  EVEN  ODD

Stop Bit  1  2

Flow Control  NONE  ER(DTR/CTS)  XON/XOFF

Timeout  (sec)

Retry

Wait To Send  (ms)

RI / VCC  RI  VCC

In the case of RS232C, you can select the 9th pin to RI (Input) or VCC (5V Power Supply). If you use the Digital's RS232C Isolation Unit, please select it to VCC.

Device-Specific Settings

Allowable Number of Devices/PLCs  [Add Device](#)

No.	Device Name	Settings
<input type="button" value="Add"/>	1	PLC1 <input type="text" value="Series=SRZ[Z-CT].Device Address=0"/> <input type="button" value="Add Indirect Device"/>

#### NOTE

- Setting value for Wait To Send differs depending on the External Device. Please refer to the manual of the External Device for more details.

### ◆ Device Setting

To display the [Individual Device Settings] dialog box, from [Device-Specific Settings] in the [Device/PLC] window, select the external device and click [Settings] .

To connect multiple External Devices, from [Device-Specific Settings] in the [Device/PLC] window, click [Add Device] to add another External Device.



### ■ Settings of External Device

Use the unit address setting switch on the front of the Temperature Controller and the DIP switch on the side of the Temperature Controller for communication settings of the External Device.

Please refer to the manual of the Temperature Controller for more details.

### ◆ Procedure

1. Use the unit address setting switch on the front of the Temperature Controller to set the slave address.  
The number added 32 to the set value becomes the slave address.
2. Use the DIP switch on the side of the Temperature Controller to set the speed, data bit configuration, and communication protocol.
3. After completing the settings, turn ON the Temperature Controller again.

### ◆ Setting Value

Unit address setting switch

Slave address setting	0
-----------------------	---

DIP Switch

SW	Settings	Description
1	OFF	Speed: 19200 bps
2	ON	
3	OFF	Data bit configuration: Data length 8 bits, no parity, stop 1 bit
4	OFF	
5	ON	
6	OFF	Communication protocol: RKC communication
7	OFF	Fixed
8	OFF	Fixed

**NOTE** • Parameters to be set vary depending on the Temperature Controller. Please refer to the manual of the Temperature Controller for more details.

### 3.43 Setting Example 43

#### ■ Settings of GP-Pro EX

##### ◆ Communication Settings

To display the setup screen, from the [Project] menu, point to [System Settings] and select [Device/PLC].

- 
- NOTE** • Setting value for Wait To Send differs depending on the External Device. Please refer to the manual of the External Device for more details.
-

### ◆ Device Setting

To display the [Individual Device Settings] dialog box, from [Device-Specific Settings] in the [Device/PLC] window, select the external device and click [Settings] .

To connect multiple External Devices, from [Device-Specific Settings] in the [Device/PLC] window, click [Add Device] to add another External Device.



### ■ Settings of External Device

Use the unit address setting switch on the front of the Temperature Controller and the DIP switch on the side of the Temperature Controller for communication settings of the External Device.

Please refer to the manual of the Temperature Controller for more details.

### ◆ Procedure

1. Use the unit address setting switch on the front of the Temperature Controller to set the slave address.
2. Use the DIP switch on the side of the Temperature Controller to set the speed, data bit configuration, and communication protocol.
3. After completing the settings, turn ON the Temperature Controller again.

### ◆ Setting Value

Unit address setting switch

Slave address setting	0
-----------------------	---

DIP Switch

SW	Settings	Description
1	OFF	Speed: 19200 bps
2	ON	
3	OFF	Communication protocol: Host communication (RKC communication) Data length 8 bits, no parity, stop 1 bit

#### NOTE

- Parameters to be set vary depending on the Temperature Controller. Please refer to the manual of the Temperature Controller for more details.

### 3.44 Setting Example 44

#### ■ Settings of GP-Pro EX

##### ◆ Communication Settings

To display the setup screen, from the [Project] menu, point to [System Settings] and select [Device/PLC].

Device/PLC 1

Summary [Change Device/PLC](#)

Manufacturer  Series  Port

Text Data Mode  [Change](#)

Communication Settings

SIO Type  RS232C  RS422/485(2wire)  RS422/485(4wire)

Speed

Data Length  7  8

Parity  NONE  EVEN  ODD

Stop Bit  1  2

Flow Control  NONE  ER(DTR/CTS)  XON/XOFF

Timeout  (sec)

Retry

Wait To Send  (ms)

RI / VCC  RI  VCC

In the case of RS232C, you can select the 9th pin to RI (Input) or VCC (5V Power Supply). If you use the Digital's RS232C Isolation Unit, please select it to VCC.

Device-Specific Settings

Allowable Number of Devices/PLCs  [Add Device](#)

No.	Device Name	Settings
<input type="button" value="1"/>	<input type="text" value="PLC1"/>	<input type="text" value="Series=SRZ(Z-COM),Device Address=0"/>

- NOTE** • Setting value for Wait To Send differs depending on the External Device. Please refer to the manual of the External Device for more details.

### ◆ Device Setting

To display the [Individual Device Settings] dialog box, from [Device-Specific Settings] in the [Device/PLC] window, select the external device and click [Settings] .

To connect multiple External Devices, from [Device-Specific Settings] in the [Device/PLC] window, click [Add Device] to add another External Device.



### ■ Settings of External Device

Use the unit address setting switch on the front of the Temperature Controller and the DIP switch on the side of the Temperature Controller for communication settings of the External Device.

Please refer to the manual of the Temperature Controller for more details.

### ◆ Procedure

1. Use the unit address setting switch on the front of the Temperature Controller to set the slave address.
2. Use the DIP switch on the side of the Temperature Controller to set the speed, data bit configuration, and communication protocol.
3. After completing the settings, turn ON the Temperature Controller again.

### ◆ Setting Value

Unit address setting switch

Slave address setting	0
-----------------------	---

DIP Switch

SW	Settings	Description
1	OFF	Speed: 19200 bps
2	ON	
3	OFF	Communication protocol: Host communication (RKC communication) Data length 8 bits, no parity, stop 1 bit

#### NOTE

- Parameters to be set vary depending on the Temperature Controller. Please refer to the manual of the Temperature Controller for more details.

### 3.45 Setting Example 45

#### ■ Settings of GP-Pro EX

##### ◆ Communication Settings

To display the setup screen, from the [Project] menu, point to [System Settings] and select [Device/PLC].

Device/PLC 1

Summary [Change Device/PLC](#)

Manufacturer  Series  Port

Text Data Mode  [Change](#)

Communication Settings

SI0 Type  RS232C  RS422/485(2wire)  RS422/485(4wire)

Speed

Data Length  7  8

Parity  NONE  EVEN  ODD

Stop Bit  1  2

Flow Control  NONE  ER(DTR/CTS)  XON/XOFF

Timeout  (sec)

Retry

Wait To Send  (ms)

RI / VCC  RI  VCC

In the case of RS232C, you can select the 9th pin to RI (Input) or VCC (5V Power Supply). If you use the Digital's RS232C Isolation Unit, please select it to VCC.

Device-Specific Settings

Allowable Number of Devices/PLCs  [Add Device](#)

No.	Device Name	Settings
<input type="button" value="Add"/> 1	<input type="text" value="PLC1"/>	<input type="text" value="Series=SRZ(Z-COM),Device Address=0"/>

- 
- NOTE** • Setting value for Wait To Send differs depending on the External Device. Please refer to the manual of the External Device for more details.
-



### ◆ Device Setting

To display the [Individual Device Settings] dialog box, from [Device-Specific Settings] in the [Device/PLC] window, select the external device and click [Settings] .

To connect multiple External Devices, from [Device-Specific Settings] in the [Device/PLC] window, click [Add Device] to add another External Device.



### ■ Settings of External Device

Use the unit address setting switch on the front of the Temperature Controller and the DIP switch on the side of the Temperature Controller for communication settings of the External Device.

Please refer to the manual of the Temperature Controller for more details.

### ◆ Procedure

1. Use the unit address setting switch on the front of the Temperature Controller to set the slave address.
2. Use the DIP switch on the side of the Temperature Controller to set the speed, data bit configuration, and communication protocol.
3. After completing the settings, turn ON the Temperature Controller again.

### ◆ Setting Value

Unit address setting switch

Slave address setting	0
-----------------------	---

DIP Switch

SW	Settings	Description
4	ON	Speed: 19200 bps
5	OFF	Communication protocol: Host communication (RKC communication) Data length 8 bits, no parity, stop 1 bit
6	OFF	
7	OFF	
8	OFF	DIP switch setting: Enabled

**NOTE** • Parameters to be set vary depending on the Temperature Controller. Please refer to the manual of the Temperature Controller for more details.

## 3.46 Setting Example 46

### ■ Settings of GP-Pro EX

#### ◆ Communication Settings

To display the setup screen, from the [Project] menu, point to [System Settings] and select [Device/PLC].

Device/PLC 1

Summary [Change Device/PLC](#)

Manufacturer  Series  Port

Text Data Mode  [Change](#)

Communication Settings

RS232C
  RS422/485(2wire)
  RS422/485(4wire)

Speed

Data Length  7  8

Parity  NONE  EVEN  ODD

Stop Bit  1  2

Flow Control  NONE  ER(DTR/CTS)  XON/XOFF

Timeout  (sec)

Retry

Wait To Send  (ms)

RI / VCC
  RI
  VCC

In the case of RS232C, you can select the 9th pin to RI (Input) or VCC (5V Power Supply). If you use the Digital's RS232C Isolation Unit, please select it to VCC.

Device-Specific Settings

Allowable Number of Devices/PLCs  [Add Device](#)

No.	Device Name	Settings
<input type="button" value="Add"/> 1	<input type="text" value="PLC1"/>	<input type="text" value="Series=SRZ(Q-COM),Device Address=0"/>

**NOTE** • Setting value for Wait To Send differs depending on the External Device. Please refer to the manual of the External Device for more details.

### ◆ Device Setting

To display the [Individual Device Settings] dialog box, from [Device-Specific Settings] in the [Device/PLC] window, select the external device and click [Settings] .

To connect multiple External Devices, from [Device-Specific Settings] in the [Device/PLC] window, click [Add Device] to add another External Device.



### ■ Settings of External Device

Use the unit address setting switch on the front of the Temperature Controller and the DIP switch on the side of the Temperature Controller for communication settings of the External Device.

Please refer to the manual of the Temperature Controller for more details.

### ◆ Procedure

1. Use the unit address setting switch on the front of the Temperature Controller to set the slave address.
2. Use the DIP switch on the side of the Temperature Controller to set the speed, data bit configuration, and communication protocol.
3. After completing the settings, turn ON the Temperature Controller again.

### ◆ Setting Value

Unit address setting switch

Slave address setting	0
-----------------------	---

DIP Switch

SW	Settings	Description
4	ON	Speed: 19200 bps
5	OFF	Communication protocol: Host communication (RKC communication) Data length 8 bits, no parity, stop 1 bit
6	OFF	
7	OFF	
8	OFF	DIP switch setting: Enabled

**NOTE** • Parameters to be set vary depending on the Temperature Controller. Please refer to the manual of the Temperature Controller for more details.

## 4 Setup Items

Set communication settings of the Display with GP-Pro EX or in offline mode of the Display.

The setting of each parameter must be identical to that of External Device.

 "3 Example of Communication Setting" (page 12)

### 4.1 Setup Items in GP-Pro EX

#### ■ Communication Settings

To display the setup screen, from the [Project] menu, point to [System Settings] and select [Device/PLC].

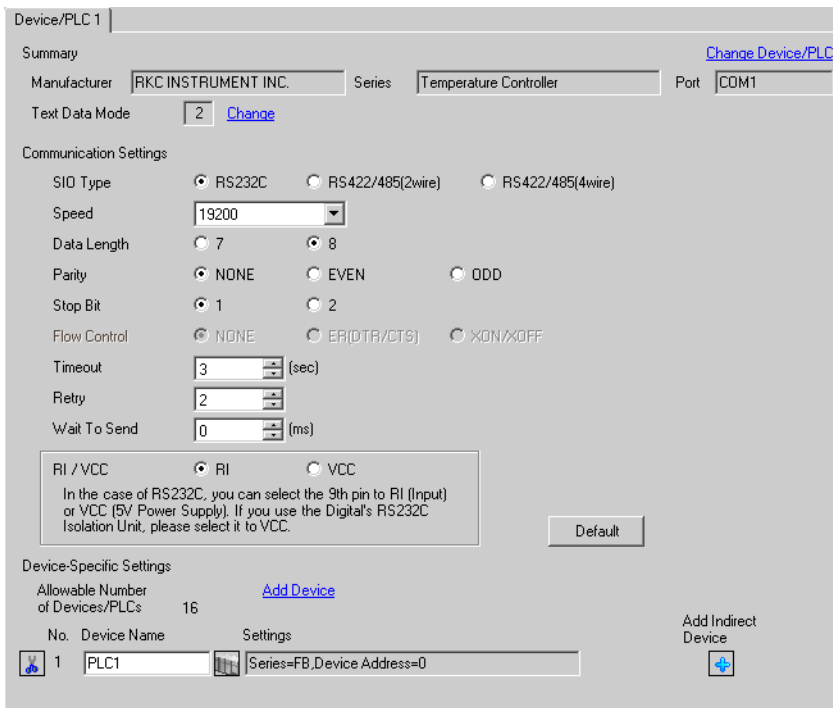

Device/PLC 1

Summary [Change Device/PLC](#)

Manufacturer  Series  Port

Text Data Mode  [Change](#)

Communication Settings

SIO Type  RS232C  RS422/485(2wire)  RS422/485(4wire)

Speed

Data Length  7  8

Parity  NONE  EVEN  ODD

Stop Bit  1  2

Flow Control  NONE  ER(DTR/CTS)  XON/XOFF

Timeout  (sec)

Retry

Wait To Send  (ms)

RI / VCC  RI  VCC  
In the case of RS232C, you can select the 9th pin to RI (Input) or VCC (5V Power Supply). If you use the Digital's RS232C Isolation Unit, please select it to VCC.

Device-Specific Settings

Allowable Number of Devices/PLCs 16 [Add Device](#)

No.	Device Name	Settings
1	PLC1	Series=FB, Device Address=0

Setup Items	Setup Description
SIO Type	Select the SIO type to communicate with the External Device.
Speed	Select speed between the External Device and the Display.
Data Length	Select data length.
Parity	Select how to check parity.
Stop Bit	Select stop bit length.
Flow Control	Display the communication control method to prevent overflow of transmission and reception data.
Timeout	Use an integer from 1 to 127 to enter the time (s) for which the Display waits for the response from the External Device.
Retry	In case of no response from the External Device, use an integer from 0 to 255 to enter how many times the Display retransmits the command.
Wait To Send	Use an integer from 0 to 255 to enter standby time (ms) for the Display from receiving packets to transmitting next commands.

Setup Items	Setup Description
RI/VCC	You can switch RI/VCC of the 9th pin when you select RS232C for SIO type. It is necessary to change RI/5V by changeover switch of IPC when connect with IPC. Please refer to the manual of the IPC for more detail.

**NOTE**

- Refer to the GP-Pro EX Reference Manual for Indirect Device.

Cf. GP-Pro EX Reference Manual "Changing the Device/PLC at Runtime (Indirect Device)"

### ■ Device Setting

To display the [Individual Device Settings] dialog box, from [Device-Specific Settings] in the [Device/PLC] window, select the external device and click [Settings] .

To connect multiple External Devices, from [Device-Specific Settings] in the [Device/PLC] window, click [Add Device] to add another External Device.



Setup Items	Setup Description
Series	Select the External Device series.
Device Address	Enter the address of the External Device, using 0 to 99.

## 4.2 Setup Items in Offline Mode

**NOTE**

- Refer to the Maintenance/Troubleshooting guide for information on how to enter offline mode or about the operation.

Cf. Maintenance/Troubleshooting Guide "Offline Mode"

- The number of the setup items to be displayed for 1 page in the offline mode depends on the Display in use. Please refer to the Reference manual for details.

### ■ Communication Settings

To display the setting screen, touch [Device/PLC Settings] from [Peripheral Settings] in offline mode. Touch the External Device you want to set from the displayed list.

Comm.	Device	Option		
Temperature Controller		[COM1]	Page 1/1	
SIO Type	RS232C			
Speed	9600			
Data Length	<input type="radio"/> 7 <input checked="" type="radio"/> 8			
Parity	<input checked="" type="radio"/> NONE <input type="radio"/> EVEN <input type="radio"/> ODD			
Stop Bit	<input checked="" type="radio"/> 1 <input type="radio"/> 2			
Flow Control	NONE			
Timeout(s)	3			
Retry	2			
Wait To Send(ms)	0			
Exit		Back		2006/03/09 16:58:58

Setup Items	Setup Description
SIO Type	Select the SIO type to communicate with the External Device. <b>IMPORTANT</b> To make the communication settings correctly, confirm the serial interface specifications of Display unit for [SIO Type]. We cannot guarantee the operation if a communication type that the serial interface does not support is specified. For details concerning the serial interface specifications, refer to the manual for Display unit.
Speed	Select speed between the External Device and the Display.
Data Length	Select data length.
Parity	Select how to check parity.
Stop Bit	Select stop bit length.
Flow Control	Display the communication control method to prevent overflow of transmission and reception data.
Timeout	Use an integer from 1 to 127 to enter the time (s) for which the Display waits for the response from the External Device.

Setup Items	Setup Description
Retry	In case of no response from the External Device, use an integer from 0 to 255 to enter how many times the Display retransmits the command.
Wait To Send	Use an integer from 0 to 255 to enter standby time (ms) for the Display from receiving packets to transmitting next commands.

#### ◆ Device Setting

To display the setting screen, touch [Device/PLC Settings] from [Peripheral Settings]. Touch the External Device you want to set from the displayed list, and touch [Device].

Comm.	Device	Option		
Temperature Controller		[COM1]	Page 1/1	
Device/PLC Name		PLC1 ▼		
Series		CB		
Device Address		0 ▼ ▲		
Exit		Back		2006/03/09 16:59:00

Setup Items	Setup Description
Device/PLC Name	Select the External Device for device setting. Device name is a title of External Device set with GP-Pro EX.(Initial value [PLC1])
Series	Display the External Device series.
Device Address	Enter the address of the External Device, using 0 to 99.

## ■ Option

To display the setting screen, touch [Device/PLC Settings] from [Peripheral Settings]. Touch the External Device you want to set from the displayed list, and touch [Option].

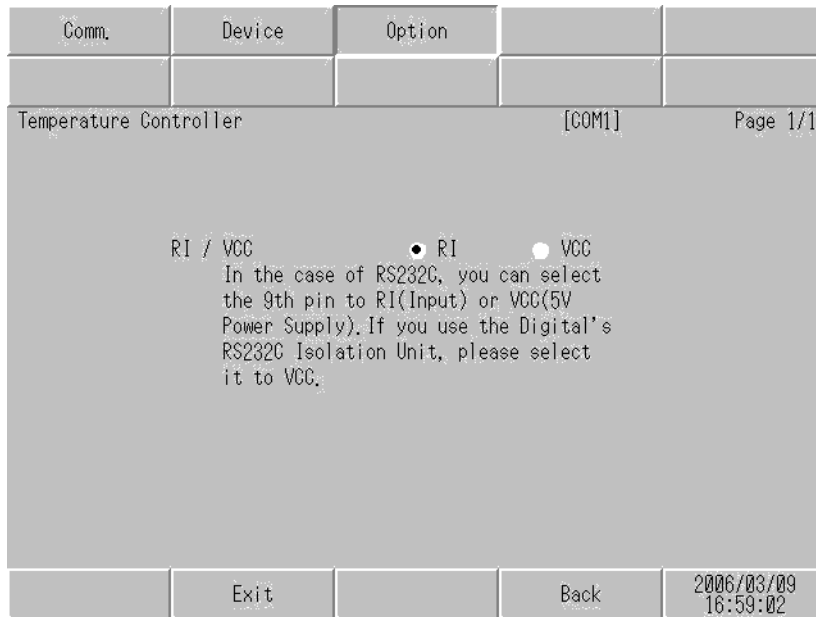

Setup Items	Setup Description
RI/VCC	You can switch RI/VCC of the 9th pin when you select RS232C for SIO type. It is necessary to change RI/5V by changeover switch of IPC when connect with IPC. Please refer to the manual of the IPC for more detail.

### NOTE

- GP-4100 series, GP-4\*0ITM and LT-4\*0ITM do not have the [Option] setting in the offline mode.



## 5 Cable Diagram

The cable diagram shown below may be different from the cable diagram recommended by RKC INSTRUMENT INC. Please be assured there is no operational problem in applying the cable diagram shown in this manual.

- The FG pin of the External Device body must be D-class grounded. Please refer to the manual of the External Device for more details.
- SG and FG are connected inside the Display. When connecting SG to the External Device, design the system not to form short-circuit loop.
- Connect the isolation unit, when communication is not stabilized under the influence of a noise etc..
- When connecting with RS422/485 (2 wire) or RS422/485 (4 wire), up to 16 units of temperature controllers can be connected. However, when connecting FB400/900 series with RS422/485 (4 wire), only up to 15 units can be connected.

Cable Diagram 1

Display (Connection Port)	Cable		Notes
GP3000* <sup>1</sup> (COM1) AGP-3302B (COM2) GP-4*0ITM (COM1) ST* <sup>2</sup> (COM2) LT3000 (COM1)	1A	COM port conversion adapter by Pro-face CA3-ADPCOM-01 + Terminal block conversion adapter by Pro-face CA3-ADPTRM-01 + User-created cable	The cable length must be 1200m or less.
	1B	User-created cable	
GP3000* <sup>3</sup> (COM2)	1C	Online adapter by Pro-face CA4-ADPONL-01 + Terminal block conversion adapter by Pro-face CA3-ADPTRM-01 + User-created cable	
	1D	Online adapter by Pro-face CA4-ADPONL-01 + User-created cable	
IPC* <sup>4</sup>	1E	COM port conversion adapter by Pro-face CA3-ADPCOM-01 + Terminal block conversion adapter by Pro-face CA3-ADPTRM-01 + User-created cable	
	1F	User-created cable	
GP-4106 (COM1)	1G	User-created cable	

Display (Connection Port)	Cable		Notes
GP-4107 (COM1) GP-4*03T* <sup>5</sup> (COM2) GP-4203T (COM1)	1H	User-created cable	The cable length must be 1200m or less.
GP4000* <sup>6</sup> (COM2) GP-4201T (COM1)	1I	RS-422 terminal block conversion adapter by Pro-face PFXZCBADTM1* <sup>7</sup> + User-created cable	
	1B	User-created cable	
LT-4*01TM (COM1)	1J	RJ45 RS-485 Cable (5m) by Pro-face PFXZLMCBJR81	

\*1 All GP3000 models except AGP-3302B

\*2 All ST models except AST-3211A and AST-3302B

\*3 All GP3000 models except GP-3200 series and AGP-3302B

\*4 Only the COM port which can communicate by RS-422/485 (2 wire) can be used.

☞ ■ IPC COM Port (page 9)

\*5 Except GP-4203T

\*6 All GP4000 models except GP-4100 series, GP-4\*01TM, GP-4201T and GP-4\*03T

\*7 When using a Terminal Block Conversion Adapter (CA3-ADPTRM-01) instead of the RS-422 Terminal Block Conversion Adapter, refer to Cable Diagram 1A.

1A)

- 1:1 Connection

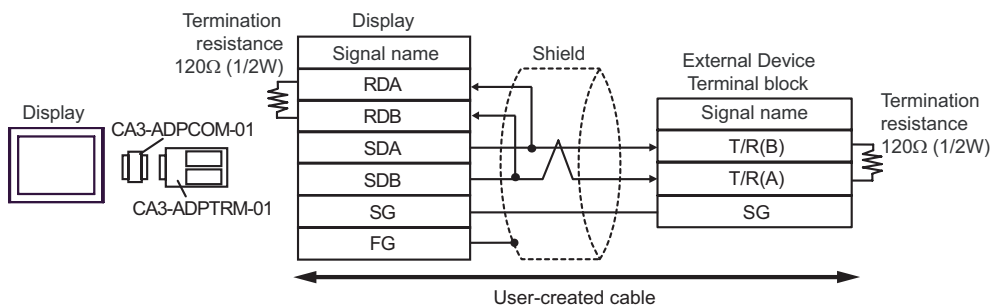

- 1:n Connection

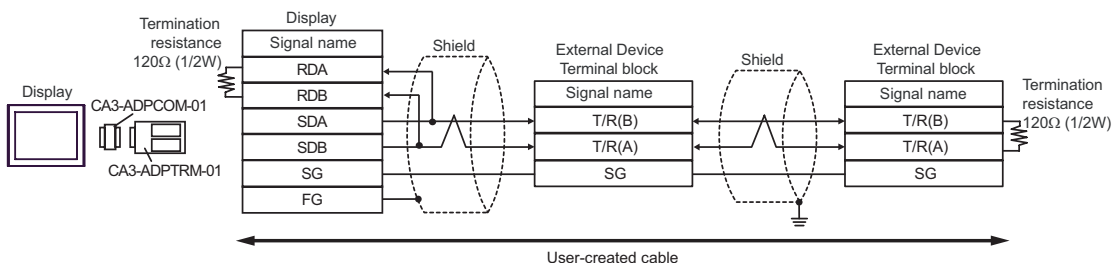

1B)

- 1:1 Connection

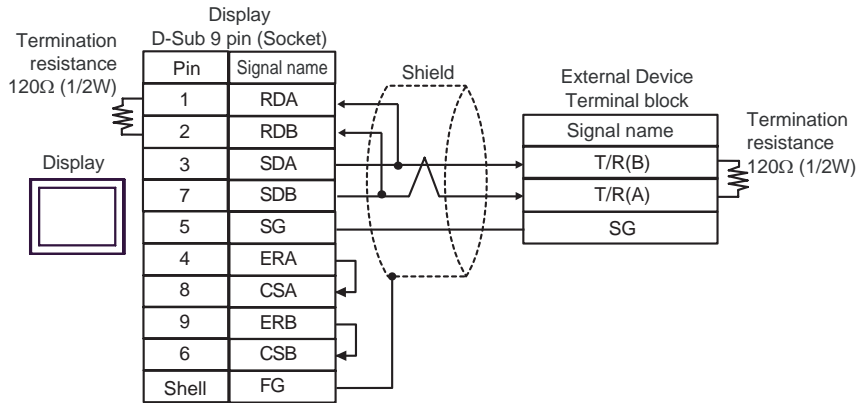

- 1:n Connection

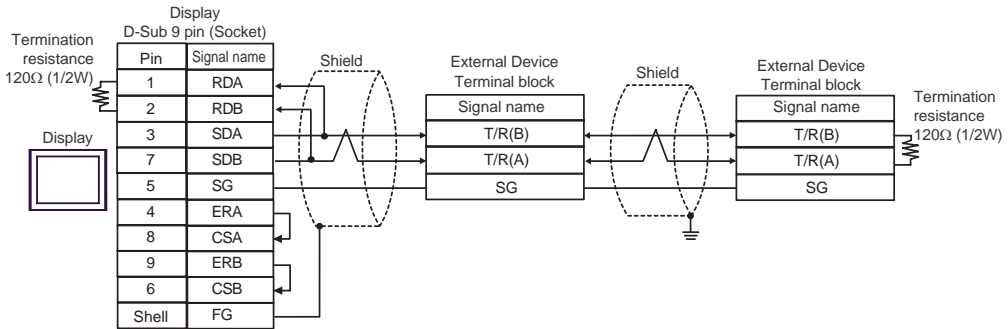

1C)

- 1:1 Connection

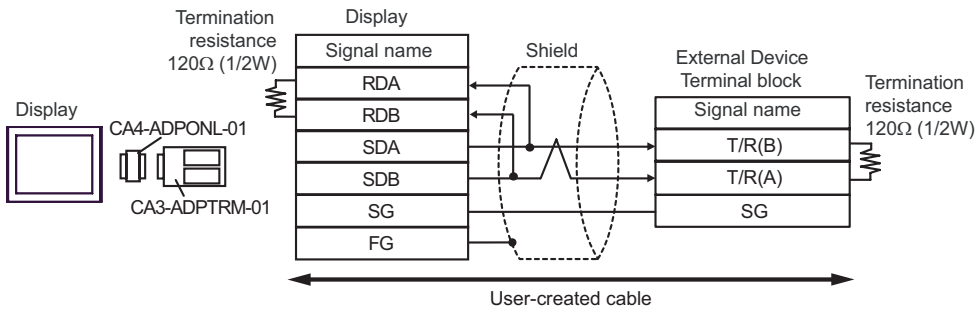

- 1:n Connection

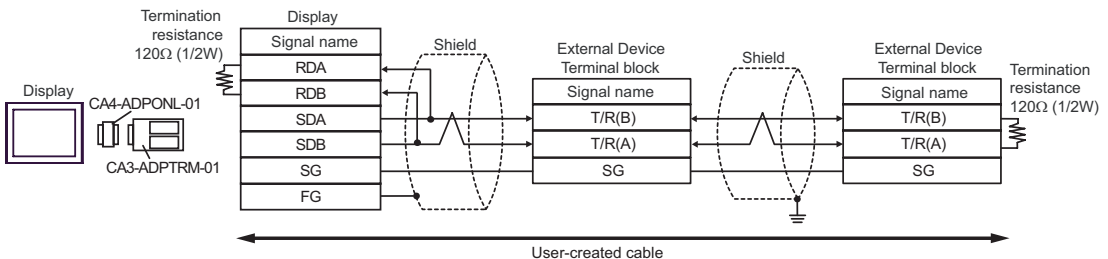

1D)

- 1:1 Connection

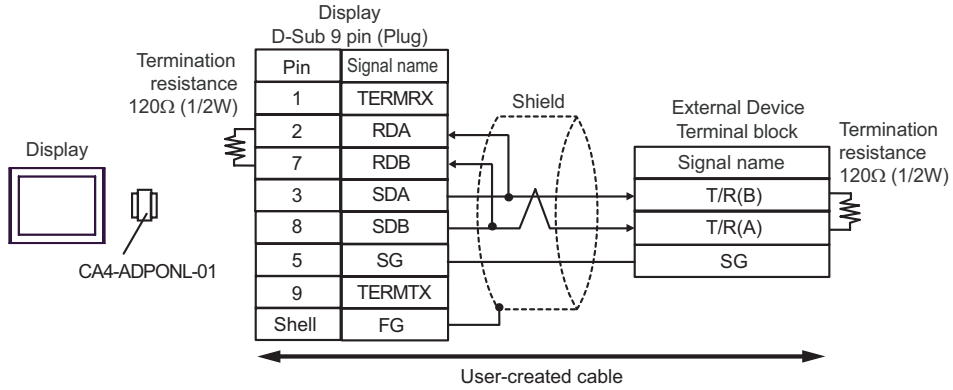

- 1:n Connection

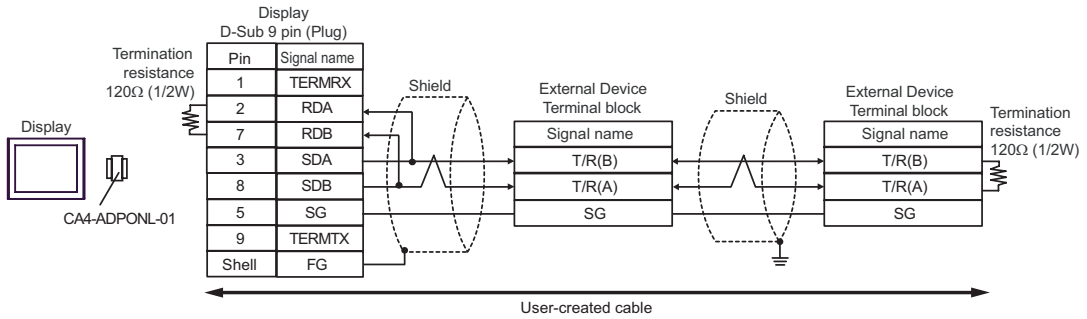

1E)

- 1:1 Connection

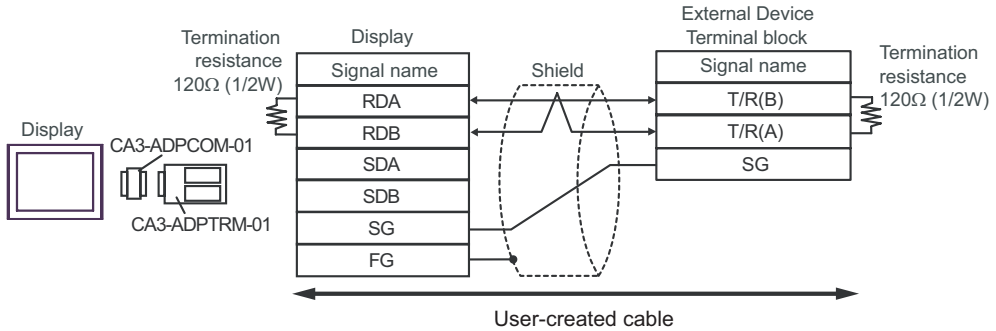

- 1:n Connection

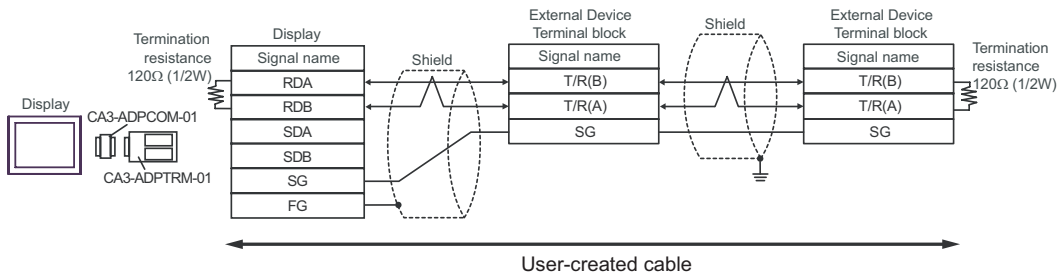

1F)

- 1:1 Connection

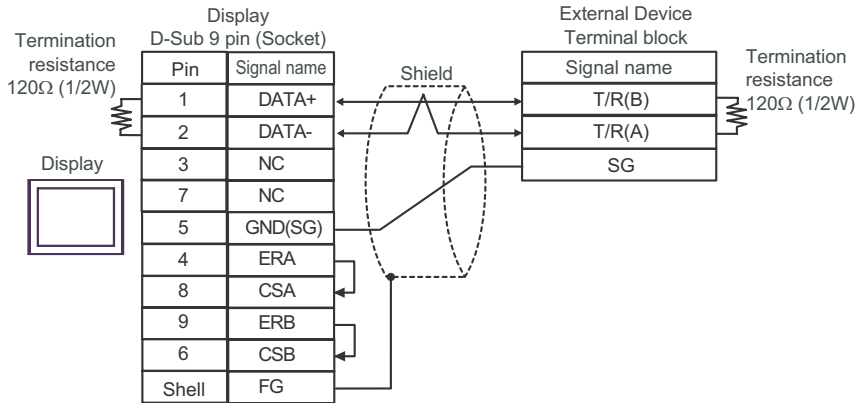

- 1:n Connection

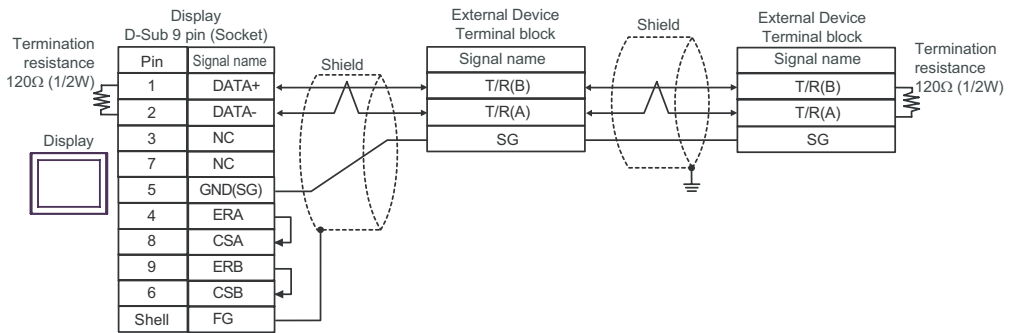

1G)

- 1:1 Connection

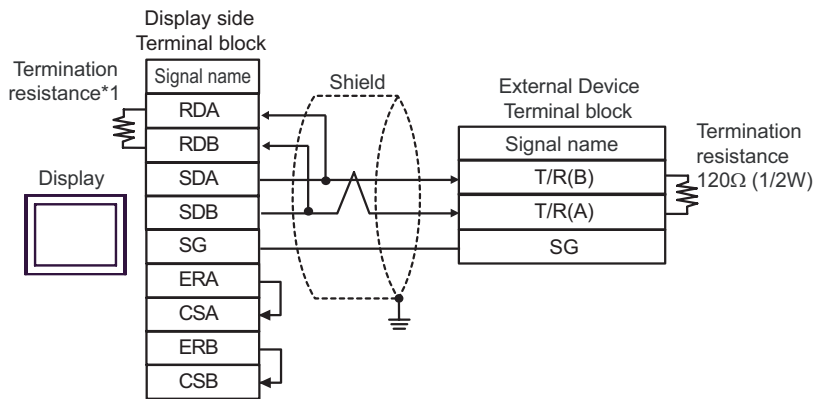

- 1:n Connection

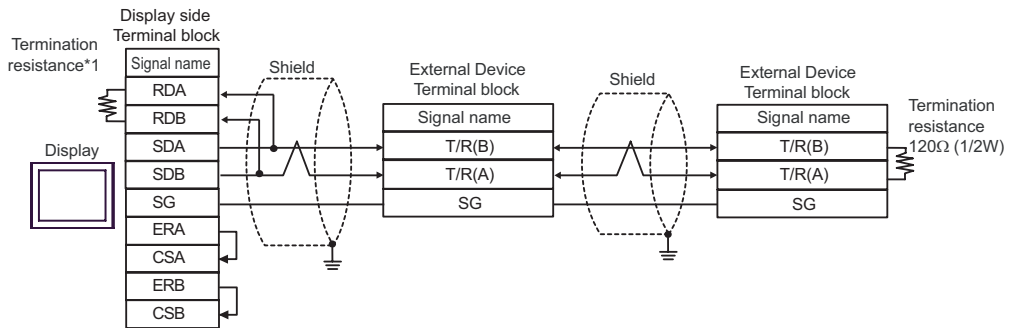

- \*1 The resistance in the Display is used as the termination resistance. Set the value of the DIP Switch on the rear of the Display as shown in the table below.

DIP Switch No.	Set Value
1	OFF
2	OFF
3	ON
4	ON

1H)

- 1:1 Connection

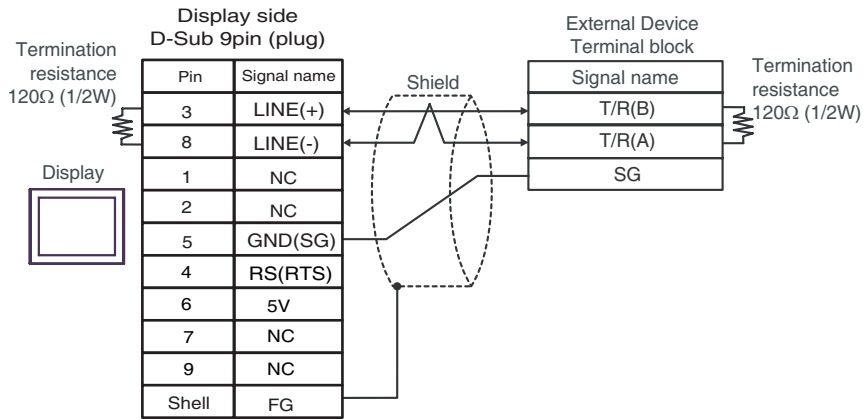

- 1:n Connection

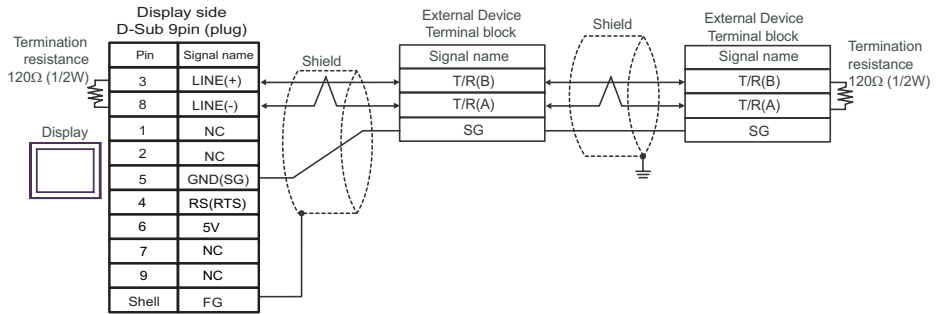

**IMPORTANT**

- The 5V output (Pin #6) on the Display is the power for the Siemens AG's PROFIBUS connector. Do not use it for other devices.

**NOTE**

- In COM on the GP-4107, the SG and FG terminals are isolated.

1I)

- 1:1 Connection

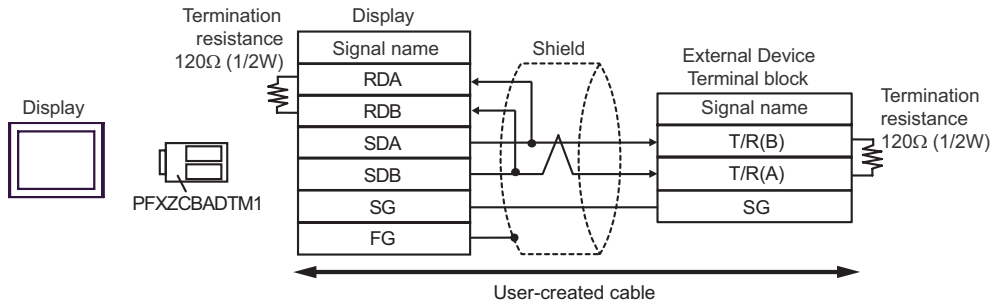

- 1:n Connection

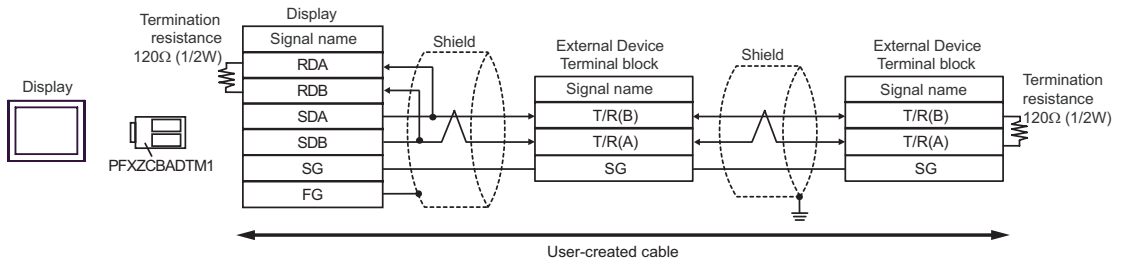

1J)

- 1:1 Connection

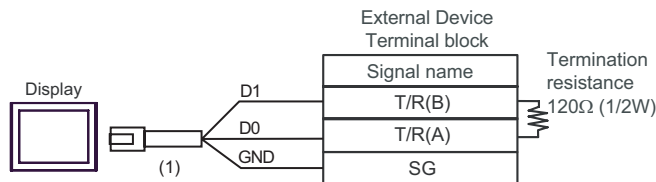

- 1:n Connection

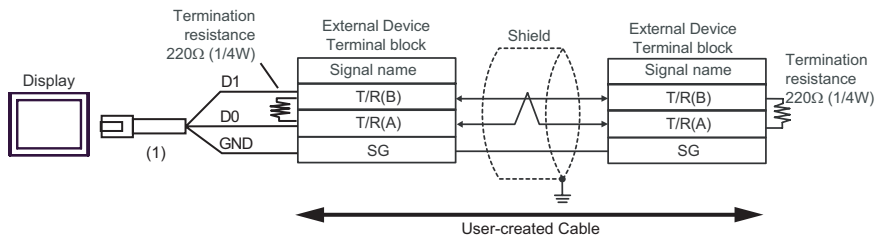

Number	Name	Notes
(1)	RJ45 RS-485 Cable (5m) by Pro-face PFXZLMCBJR81	



Cable Diagram 2

Display (Connection Port)	Cable		Notes
GP3000 (COM1) GP4000* <sup>1</sup> (COM1) ST (COM1) LT3000 (COM1) IPC* <sup>2</sup> PC/AT	2A	User-created cable	The cable length must be 15m or less.
GP-4105 (COM1)	2B	User-created cable	
LT-4*0ITM (COM1)	2C	RJ45 RS-232C Cable (5m) by Pro-face PFXZLMCBRJR21	

\*1 All GP4000 models except GP-4100 Series and GP-4203T

\*2 Only the COM port which can communicate by RS-232C can be used.

 ■ IPC COM Port (page 9)

2A)

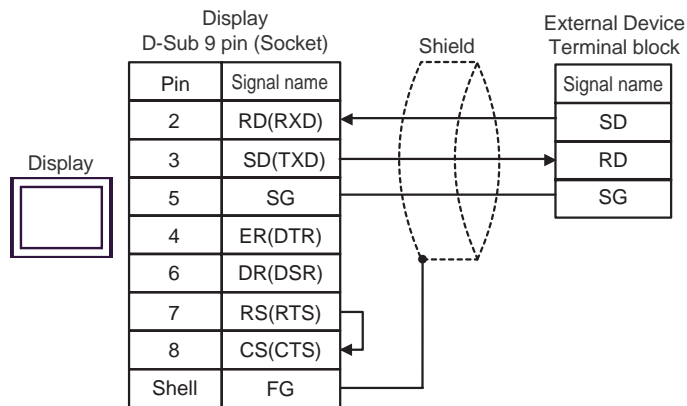

2B)

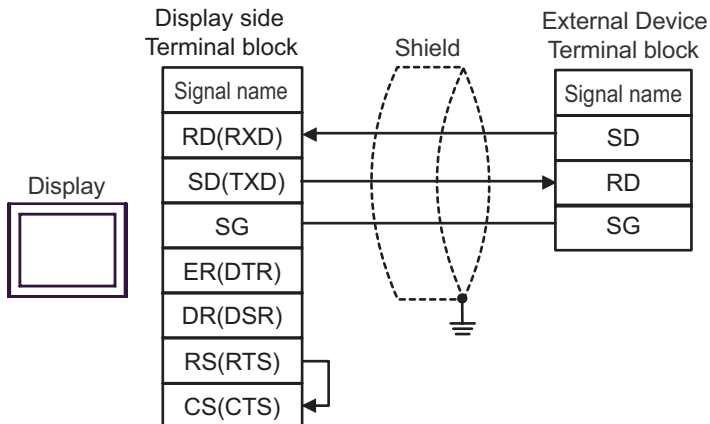

2C)

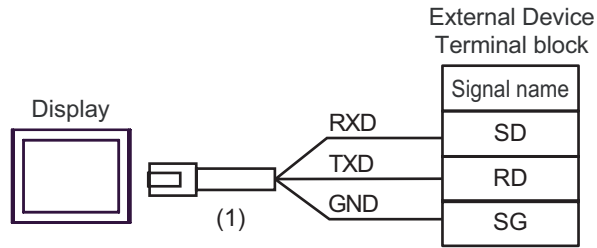

Number	Name	Notes
(1)	RJ45 RS-232C Cable (5m) by Pro-face PFXZLMCBRJ21	

Cable Diagram 3

Display (Connection Port)	Cable		Notes
GP3000* <sup>1</sup> (COM1) AGP-3302B (COM2) GP-4*01TM (COM1) ST* <sup>2</sup> (COM2) LT3000 (COM1) IPC* <sup>3</sup>	3A	COM port conversion adapter by Pro-face CA3-ADPCOM-01 + Terminal block conversion adapter by Pro-face CA3-ADPTRM-01 + User-created cable	The cable length must be 1200m or less.
	3B	User-created cable	
GP3000* <sup>4</sup> (COM2)	3C	Online adapter by Pro-face CA4-ADPONL-01 + Terminal block conversion adapter by Pro-face CA3-ADPTRM-01 + User-created cable	
	3D	Online adapter by Pro-face CA4-ADPONL-01 + User-created cable	
GP-4106 (COM1)	3E	User-created cable	
GP4000* <sup>5</sup> (COM2) GP-4201T (COM1)	3F	RS-422 terminal block conversion adapter by Pro-face PFXZCBADTM1* <sup>6</sup> + User-created cable	
	3B	User-created cable	

\*1 All GP3000 models except AGP-3302B

\*2 All ST models except AST-3211A and AST-3302B

\*3 Only the COM port which can communicate by RS-422/485 (4 wire) can be used.

 ■ IPC COM Port (page 9)

\*4 All GP3000 models except GP-3200 series and AGP-3302B

\*5 All GP4000 models except GP-4100 series, GP-4\*01TM, GP-4201T and GP-4\*03T

\*6 When using a Terminal Block Conversion Adapter (CA3-ADPTRM-01) instead of the RS-422 Terminal Block Conversion Adapter, refer to Cable Diagram 3A.

3A)

- 1:1 Connection

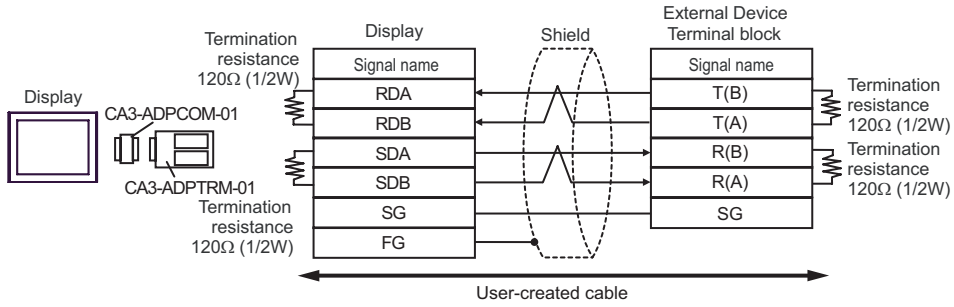

- 1:n Connection

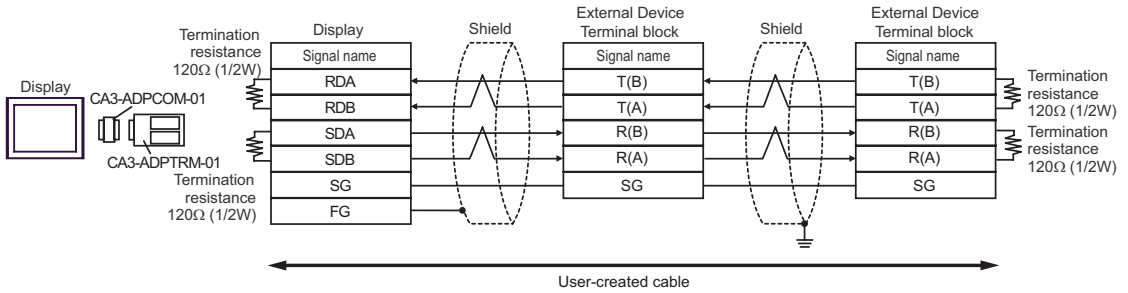

3B)

- 1:1 Connection

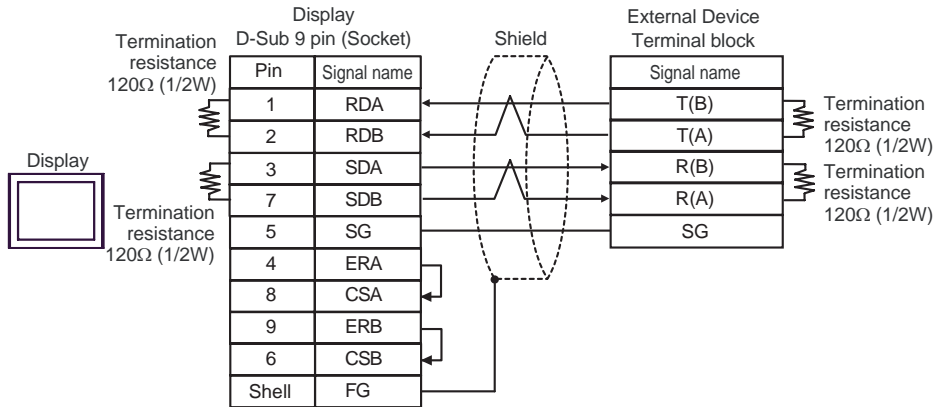

- 1:n Connection

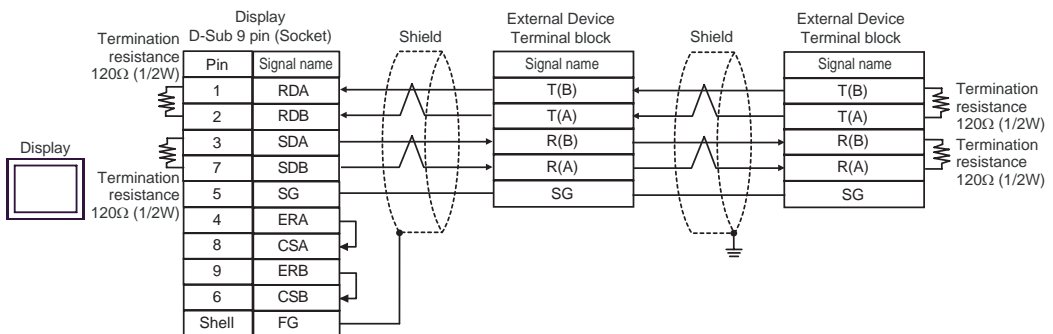

3C)

- 1:1 Connection

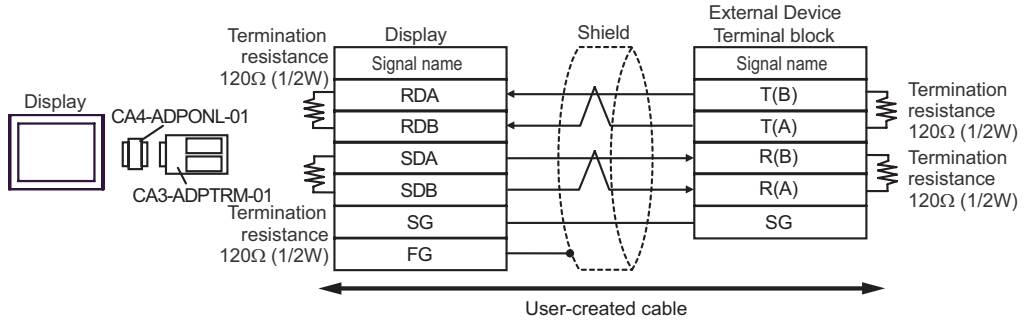

- 1:n Connection

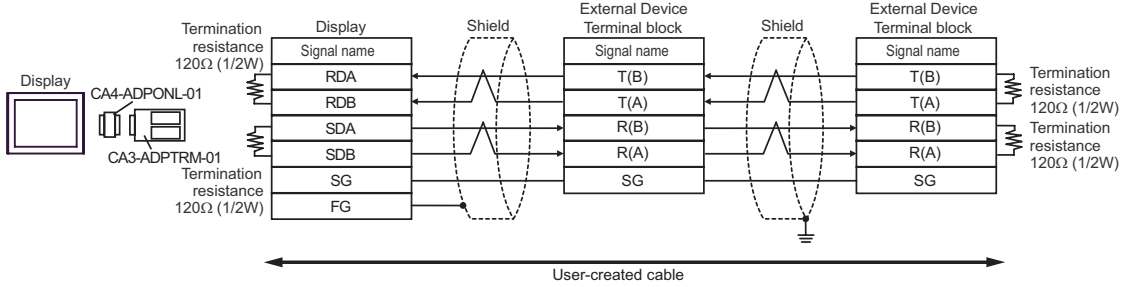

3D)

- 1:1 Connection

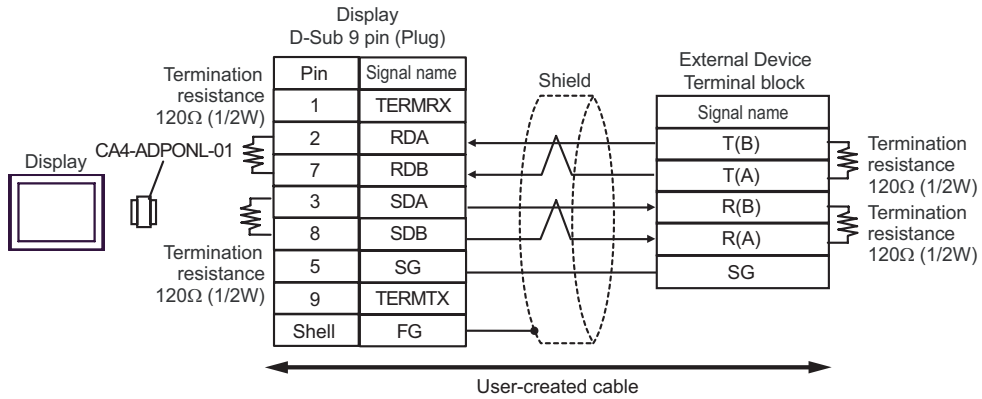

- 1:n Connection

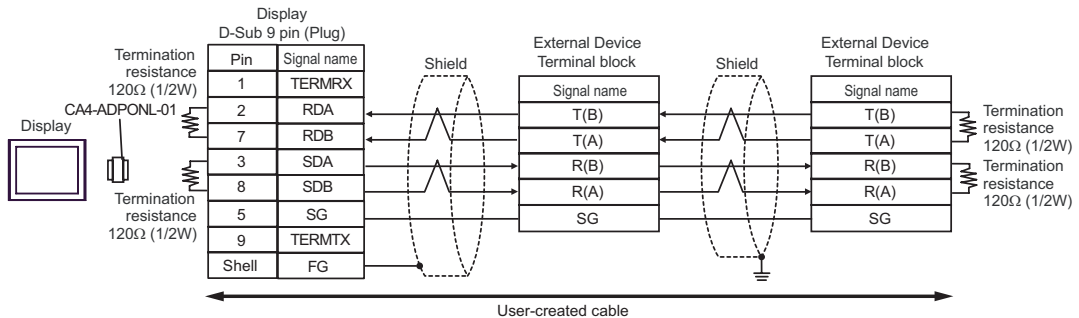

3E)

- 1:1 Connection

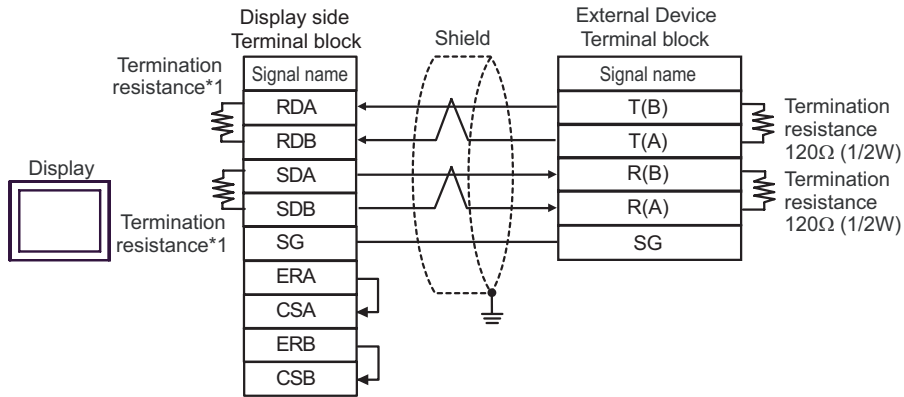

- 1:n Connection

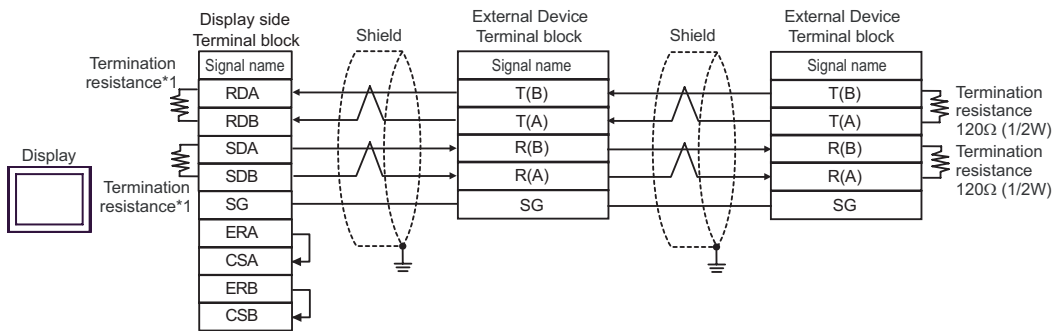

\*1 The resistance in the Display is used as the termination resistance. Set the value of the DIP Switch on the rear of the Display as shown in the table below.

DIP Switch No.	Set Value
1	ON
2	ON
3	ON
4	ON

3F)

- 1:1 Connection

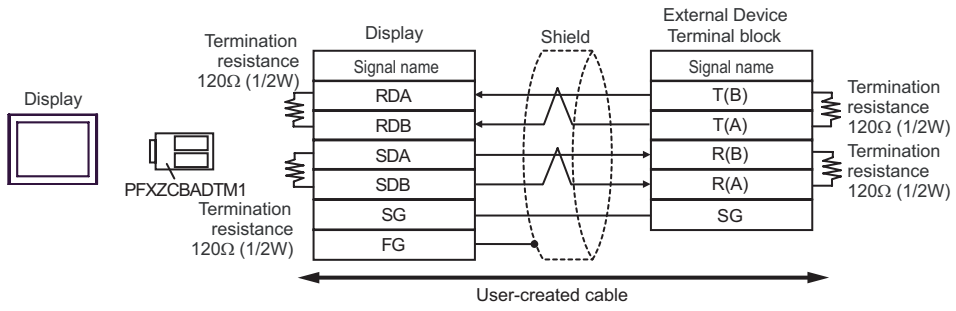

- 1:n Connection

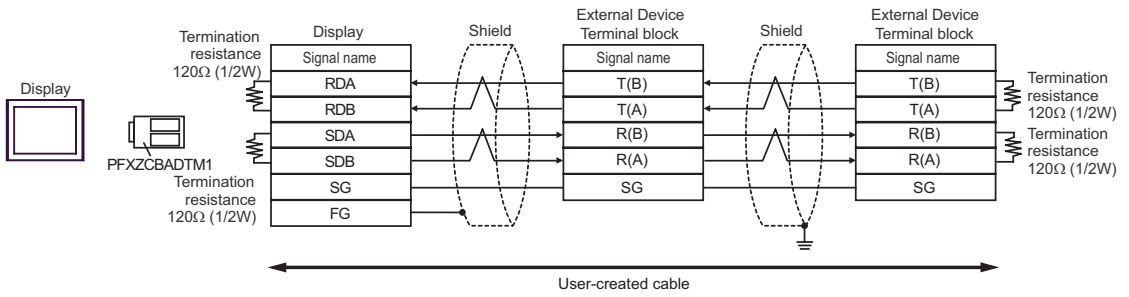

Cable Diagram 4

Display (Connection Port)	Cable		Notes
GP3000* <sup>1</sup> (COM1) AGP-3302B (COM2) GP-4*01TM (COM1) ST* <sup>2</sup> (COM2) LT3000 (COM1) IPC* <sup>3</sup>	4A	COM port conversion adapter by Pro-face CA3-ADPCOM-01 + Terminal block conversion adapter by Pro-face CA3-ADPTRM-01 + User-created cable	The cable length must be 1200m or less.
	4B	User-created cable	
GP3000* <sup>4</sup> (COM2)	4C	Online adapter by Pro-face CA4-ADPONL-01 + Terminal block conversion adapter by Pro-face CA3-ADPTRM-01 + User-created cable	
	4D	Online adapter by Pro-face CA4-ADPONL-01 + User-created cable	
GP-4106 (COM1)	4E	User-created cable	
GP4000* <sup>5</sup> (COM2) GP-4201T (COM1)	4F	RS-422 terminal block conversion adapter by Pro-face PFXZCBADTM1* <sup>6</sup> + User-created cable	
	4B	User-created cable	

\*1 All GP3000 models except AGP-3302B

\*2 All ST models except AST-3211A and AST-3302B

\*3 Only the COM port which can communicate by RS-422/485 (4 wire) can be used.

 ■ IPC COM Port (page 9)

\*4 All GP3000 models except GP-3200 series and AGP-3302B

\*5 All GP4000 models except GP-4100 series, GP-4\*01TM, GP-4201T and GP-4\*03T

\*6 When using a Terminal Block Conversion Adapter (CA3-ADPTRM-01) instead of the RS-422 Terminal Block Conversion Adapter, refer to Cable Diagram 4A.



4A)

- 1:1 Connection

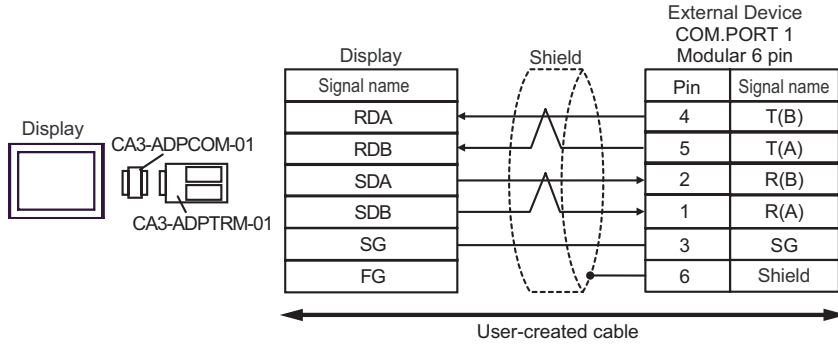

- 1:n Connection

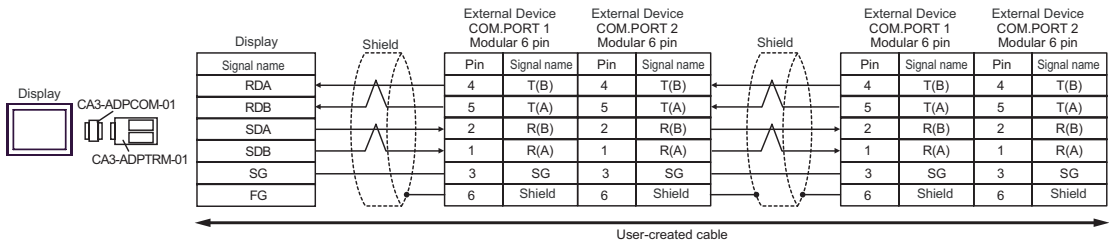

**NOTE** • Terminal resistance is not required.

4B)

- 1:1 Connection

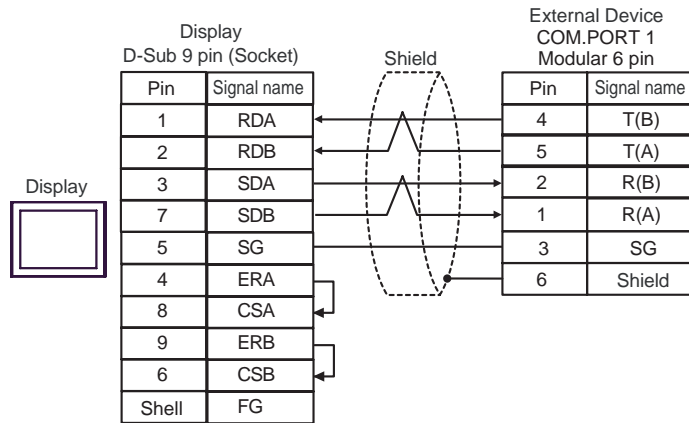

- 1:n Connection

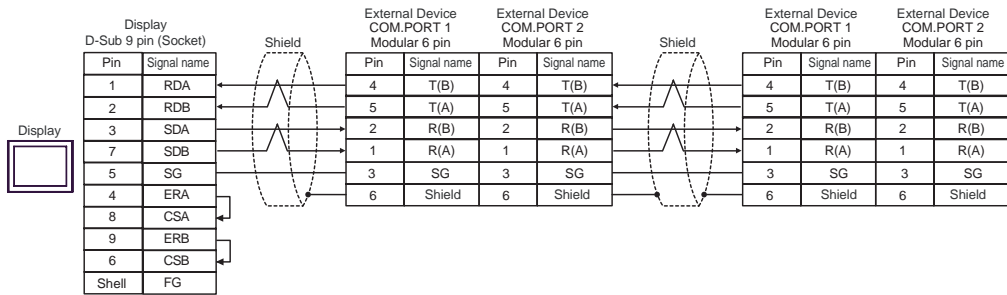

**NOTE** • Terminal resistance is not required.

4C)

- 1:1 Connection

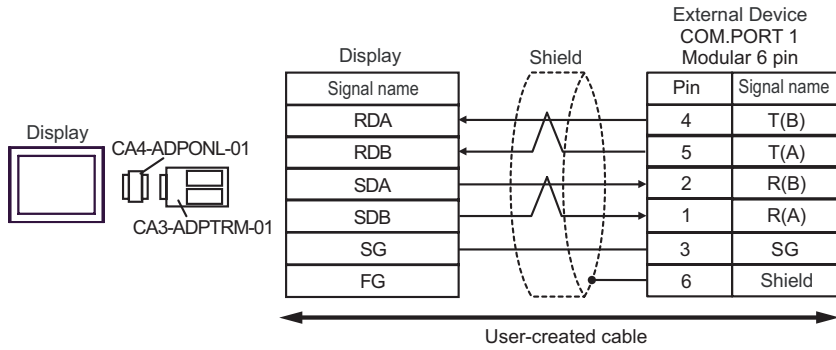

- 1:n Connection

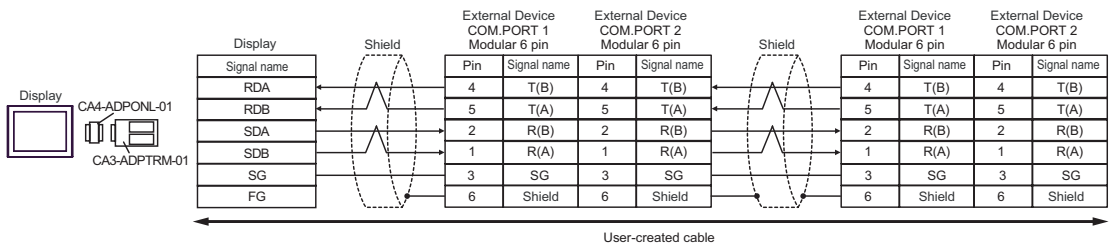

**NOTE**

- Terminal resistance is not required.

4D)

- 1:1 Connection

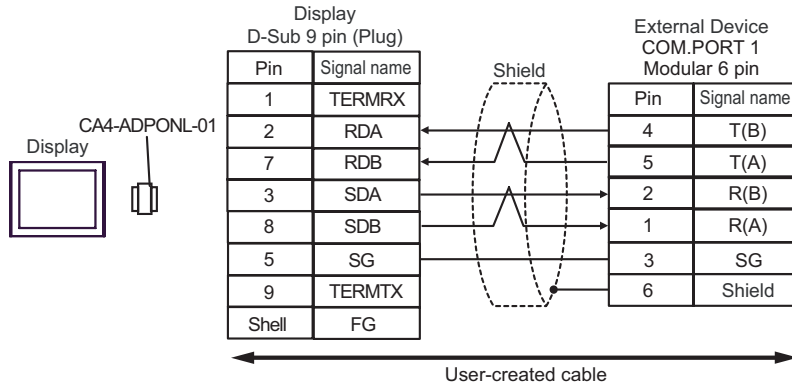

- 1:n Connection

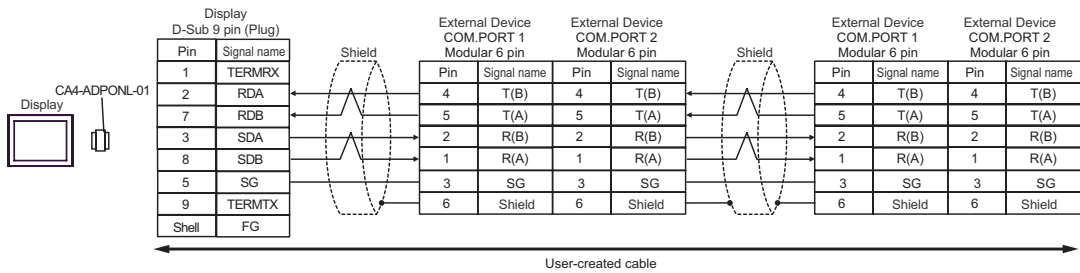

**NOTE** • Terminal resistance is not required.

4E)

- 1:1 Connection

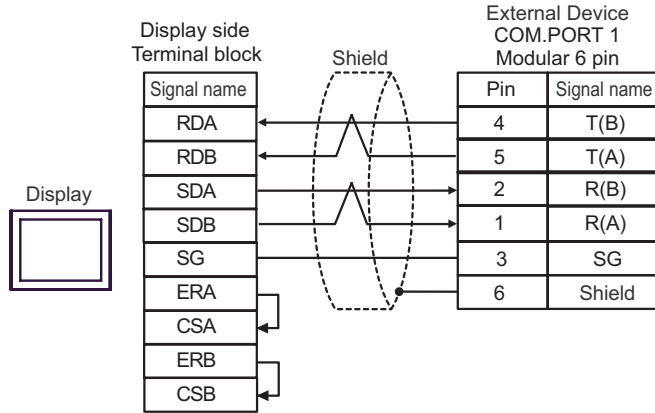

- 1:n Connection

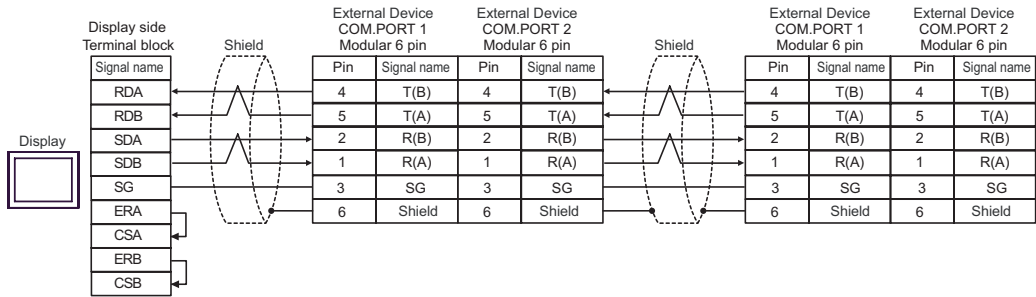

**NOTE** • Terminal resistance is not required.

4F)

- 1:1 Connection

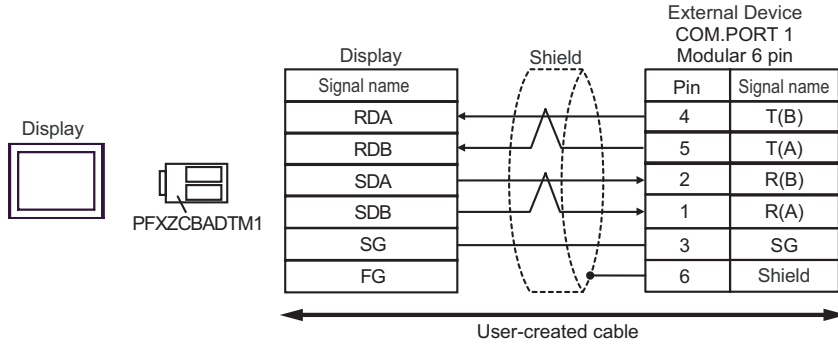

- 1:n Connection

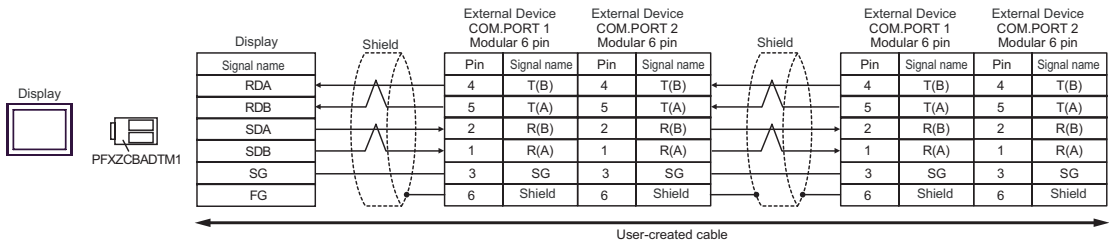

**NOTE** • Terminal resistance is not required.

Cable Diagram 5

Display (Connection Port)	Cable		Notes
GP3000* <sup>1</sup> (COM1) AGP-3302B (COM2) GP-4*0ITM (COM1) ST* <sup>2</sup> (COM2) LT3000 (COM1)	5A	COM port conversion adapter by Pro-face CA3-ADPCOM-01 + Terminal block conversion adapter by Pro-face CA3-ADPTRM-01 + User-created cable	The cable length must be 1200m or less.
	5B	User-created cable	
GP3000* <sup>3</sup> (COM2)	5C	Online adapter by Pro-face CA4-ADPONL-01 + Terminal block conversion adapter by Pro-face CA3-ADPTRM-01 + User-created cable	
	5D	Online adapter by Pro-face CA4-ADPONL-01 + User-created cable	
IPC* <sup>4</sup>	5E	COM port conversion adapter by Pro-face CA3-ADPCOM-01 + Terminal block conversion adapter by Pro-face CA3-ADPTRM-01 + User-created cable	
	5F	User-created cable	
GP-4106 (COM1)	5G	User-created cable	
GP-4107 (COM1) GP-4*03T* <sup>5</sup> (COM2) GP-4203T (COM1)	5H	User-created cable	
GP4000* <sup>6</sup> (COM2) GP-4201T (COM1)	5I	RS-422 terminal block conversion adapter by Pro-face PFXZCBADTM1* <sup>7</sup> + User-created cable	
	5B	User-created cable	
LT-4*0ITM (COM1)	5J	RJ45 RS-485 Cable (5m) by Pro-face PFXZLMCBJR81	

\*1 All GP3000 models except AGP-3302B

\*2 All ST models except AST-3211A and AST-3302B

\*3 All GP3000 models except GP-3200 series and AGP-3302B

\*4 Only the COM port which can communicate by RS-422/485 (2 wire) can be used.

 ■ IPC COM Port (page 9)

\*5 Except GP-4203T

\*6 All GP4000 models except GP-4100 series, GP-4\*01TM, GP-4201T and GP-4\*03T

\*7 When using a Terminal Block Conversion Adapter (CA3-ADPTRM-01) instead of the RS-422 Terminal Block Conversion Adapter, refer to Cable Diagram 5A.

5A)

- 1:1 Connection

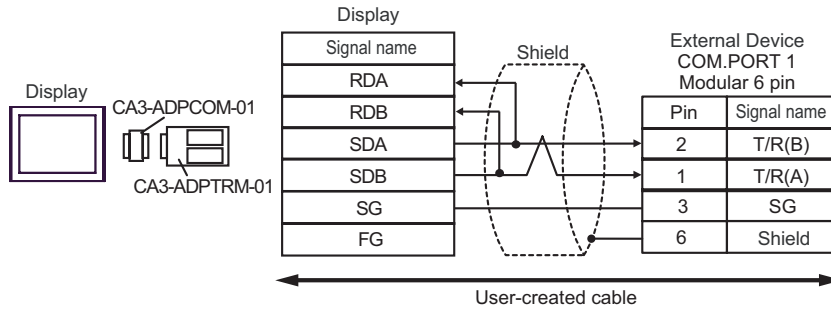

- 1:n Connection

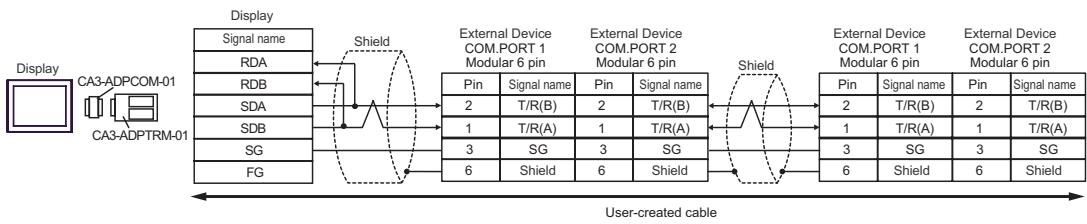

**NOTE** • Terminal resistance is not required.



5B)

- 1:1 Connection

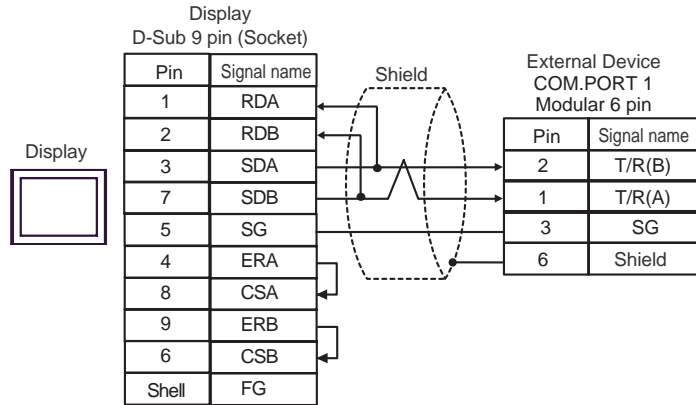

- 1:n Connection

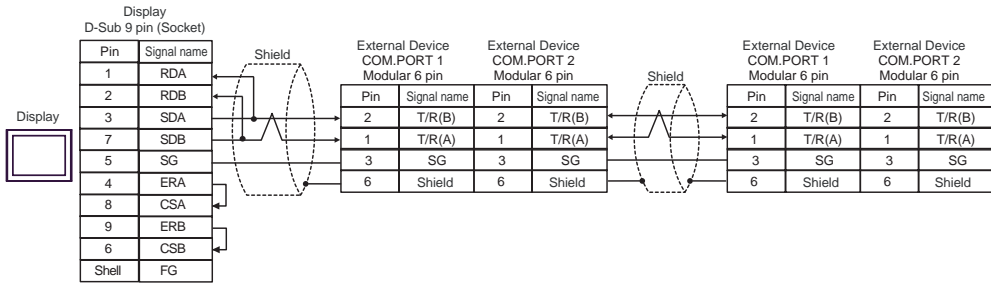

**NOTE** • Terminal resistance is not required.

5C)

- 1:1 Connection

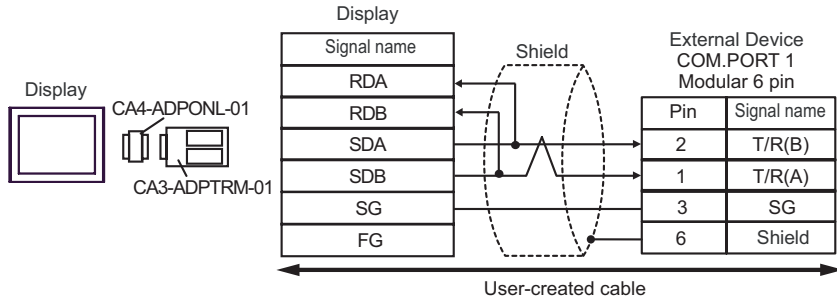

- 1:n Connection

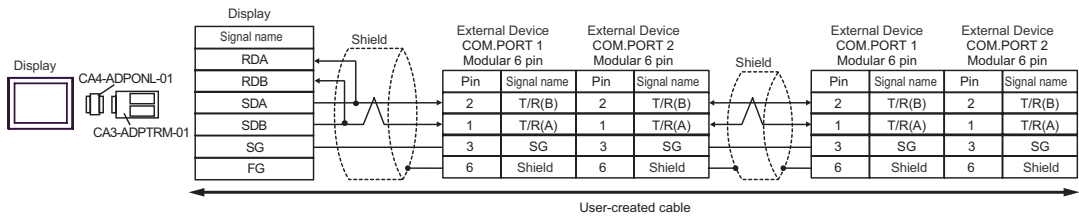

**NOTE** • Terminal resistance is not required.

5D)

- 1:1 Connection

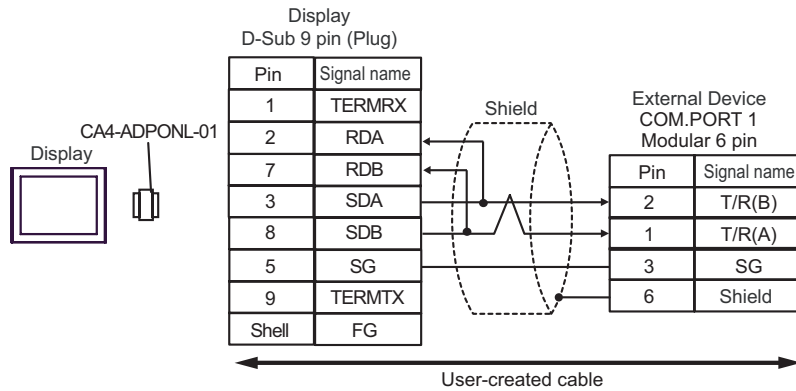

- 1:n Connection

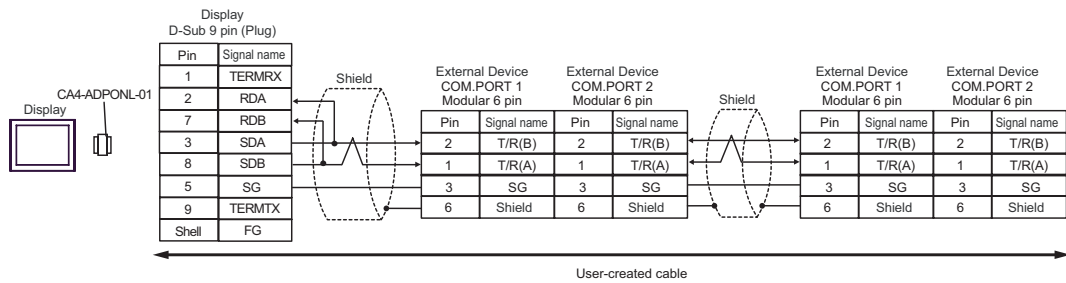

**NOTE**

- Terminal resistance is not required.

5E)

- 1:1 Connection

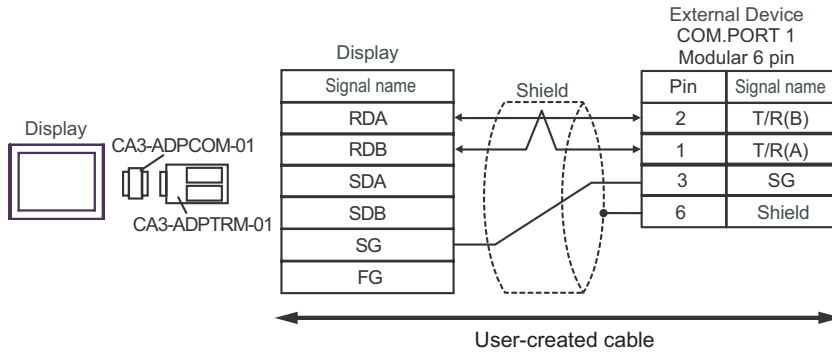

- 1:n Connection

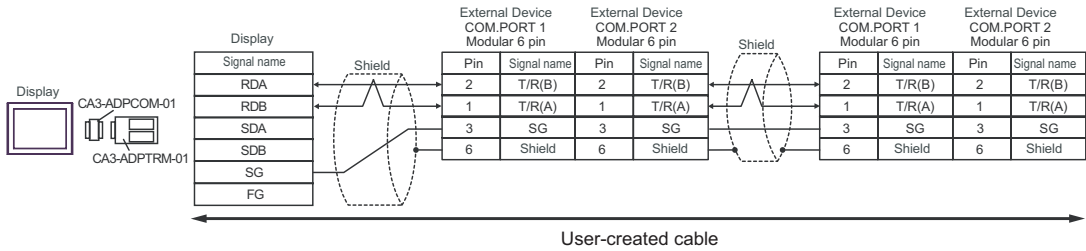

**NOTE** • Terminal resistance is not required.

5F)

- 1:1 Connection

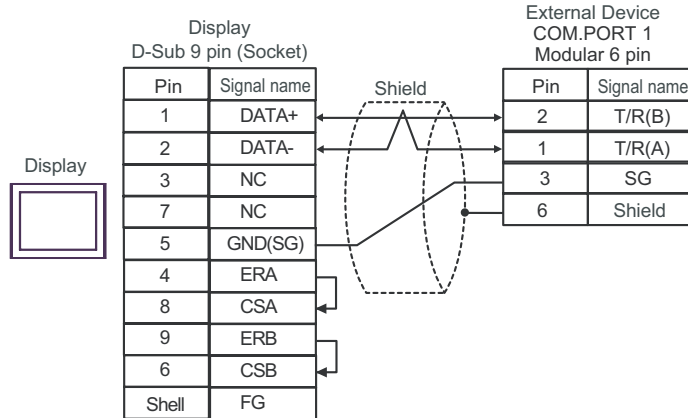

- 1:n Connection

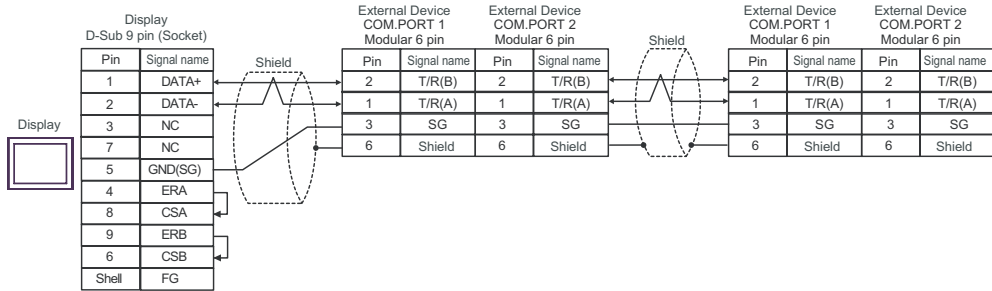

**NOTE** • Terminal resistance is not required.

5G)

- 1:1 Connection

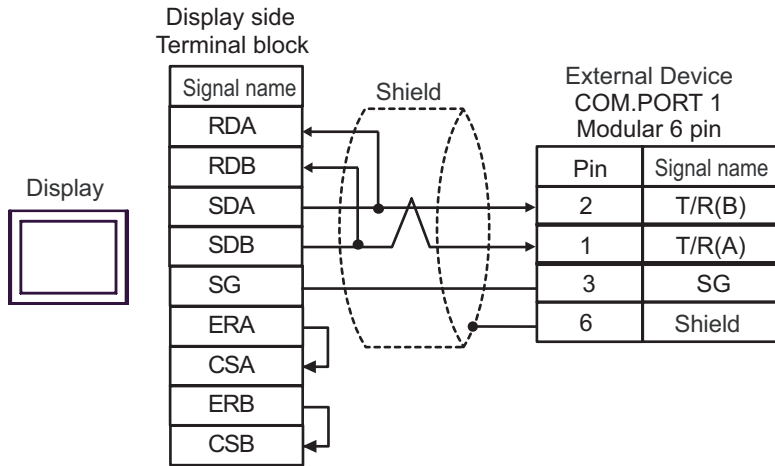

- 1:n Connection

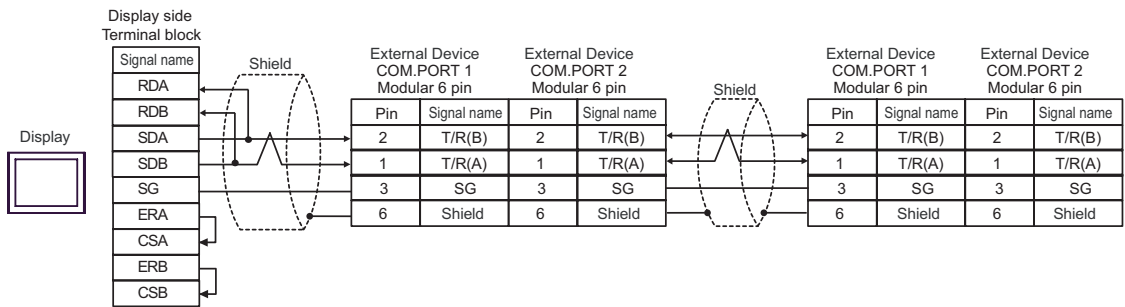

**NOTE** • Terminal resistance is not required.

5H)

- 1:1 Connection

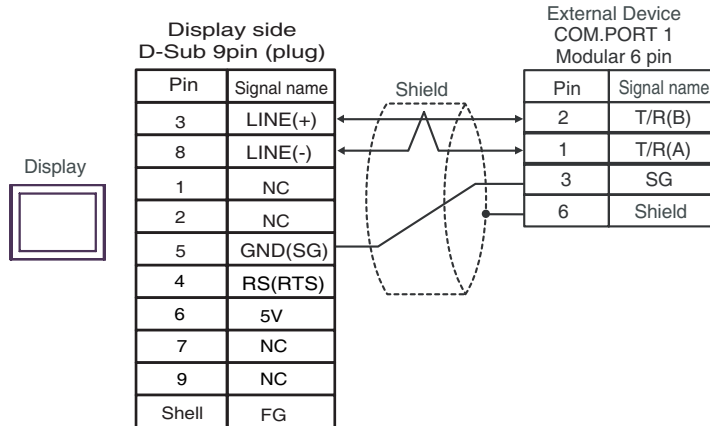

- 1:n Connection

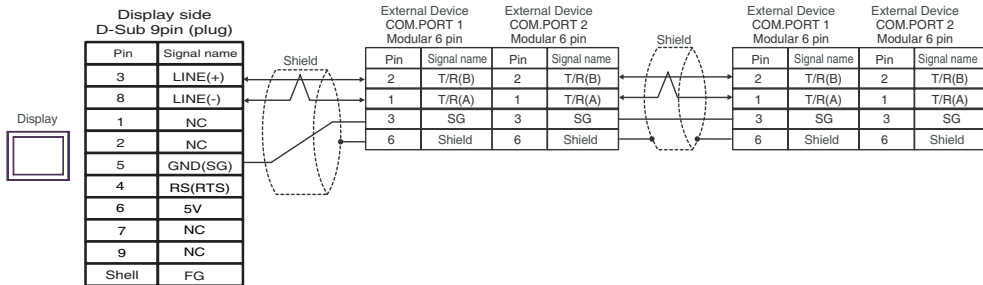

**IMPORTANT**

- The 5V output (Pin #6) on the Display is the power for the Siemens AG's PROFIBUS connector. Do not use it for other devices.

**NOTE**

- Terminal resistance is not required.
- In COM on the GP-4107, the SG and FG terminals are isolated.

5I)

- 1:1 Connection

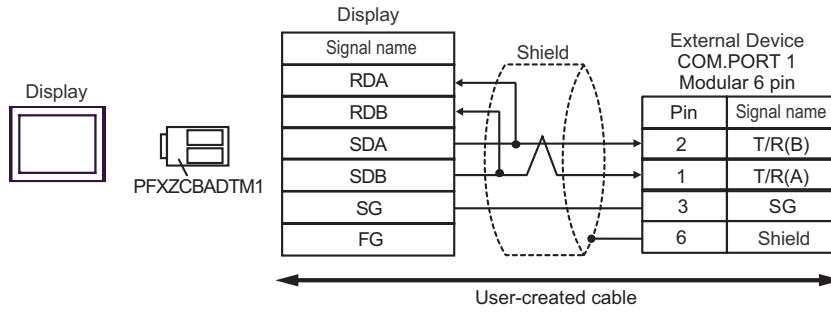

- 1:n Connection

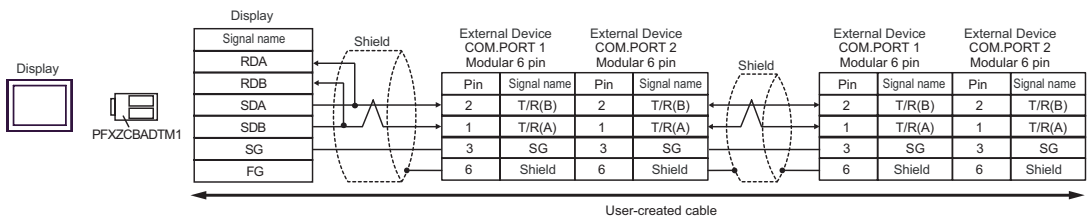

**NOTE** • Terminal resistance is not required.

5J)

- 1:1 Connection

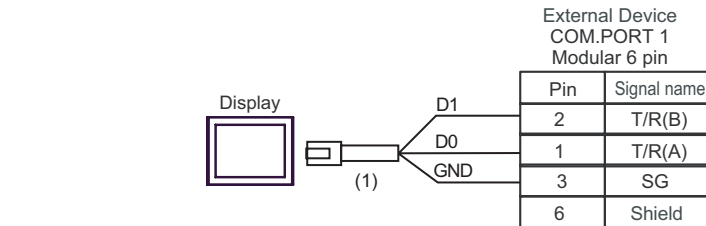

- 1:n Connection

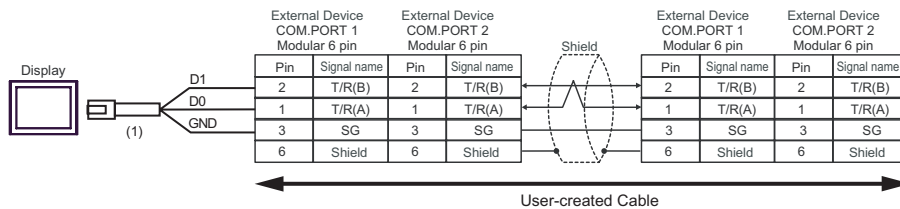

**NOTE** • Terminal resistance is not required.

Number	Name	Notes
(1)	RJ45 RS-485 Cable (5m) by Pro-face PFXZLMCBJR81	



Cable Diagram 6

Display (Connection Port)	Cable		Notes
GP3000 <sup>*1</sup> (COM1) AGP-3302B (COM2) GP-4*01TM (COM1) ST <sup>*2</sup> (COM2) LT3000 (COM1) IPC <sup>*3</sup>	6A	COM port conversion adapter by Pro-face CA3-ADPCOM-01 + Terminal block conversion adapter by Pro-face CA3-ADPTRM-01 + User-created cable	The cable length must be 1200m or less.
	6B	User-created cable	
GP3000 <sup>*4</sup> (COM2)	6C	Online adapter by Pro-face CA4-ADPONL-01 + Terminal block conversion adapter by Pro-face CA3-ADPTRM-01 + User-created cable	
	6D	Online adapter by Pro-face CA4-ADPONL-01 + User-created cable	
GP-4106 (COM1)	6E	User-created cable	
GP4000 <sup>*5</sup> (COM2) GP-4201T (COM1)	6F	RS-422 terminal block conversion adapter by Pro-face PFXZCBADTM1 <sup>*6</sup> + User-created cable	
	6B	User-created cable	

\*1 All GP3000 models except AGP-3302B

\*2 All ST models except AST-3211A and AST-3302B

\*3 Only the COM port which can communicate by RS-422/485 (4 wire) can be used.

 ■ IPC COM Port (page 9)

\*4 All GP3000 models except GP-3200 series and AGP-3302B

\*5 All GP4000 models except GP-4100 series, GP-4\*01TM, GP-4201T and GP-4\*03T

\*6 When using a Terminal Block Conversion Adapter (CA3-ADPTRM-01) instead of the RS-422 Terminal Block Conversion Adapter, refer to Cable Diagram 6A.

6A)

- 1:1 Connection

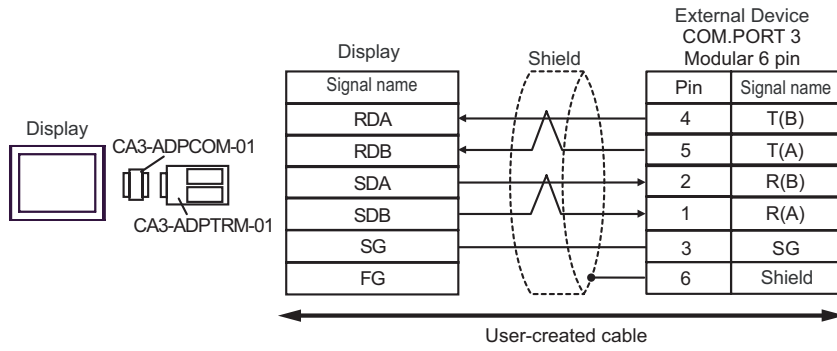

- 1:n Connection

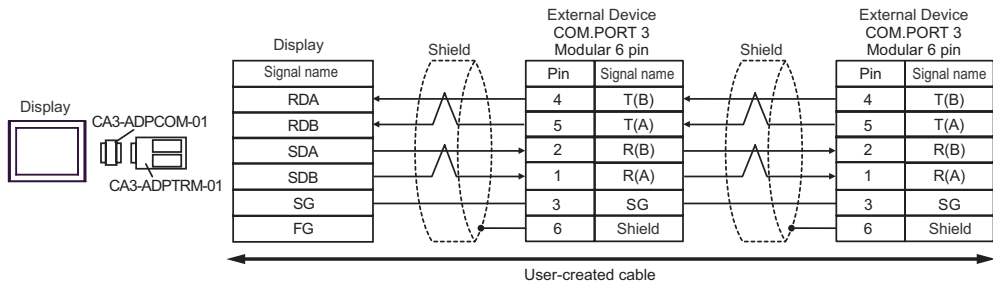

**NOTE** • Terminal resistance is not required.

6B)

- 1:1 Connection

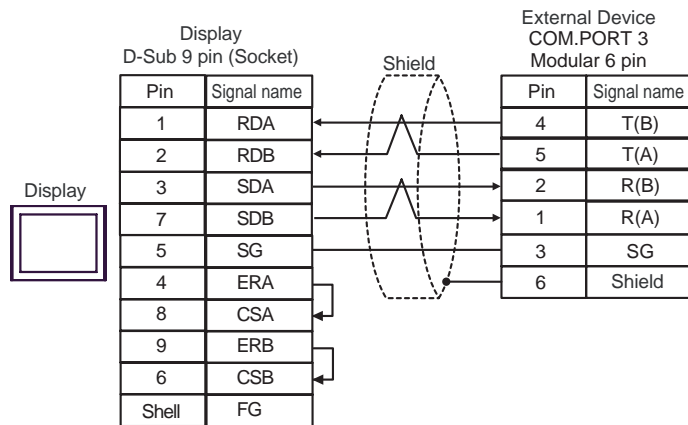

- 1:n Connection

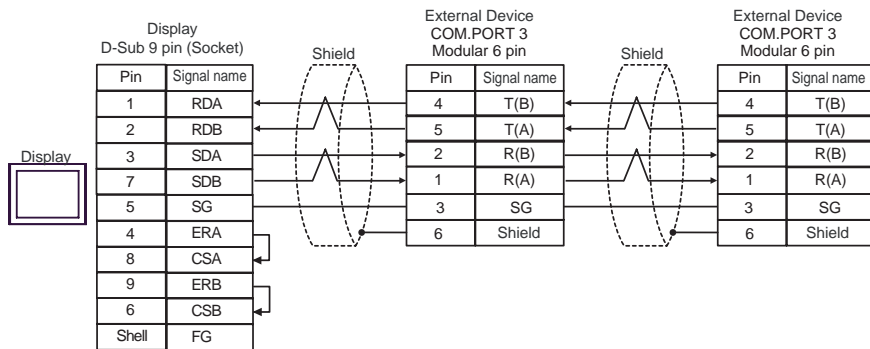

**NOTE** • Terminal resistance is not required.

6C)

- 1:1 Connection

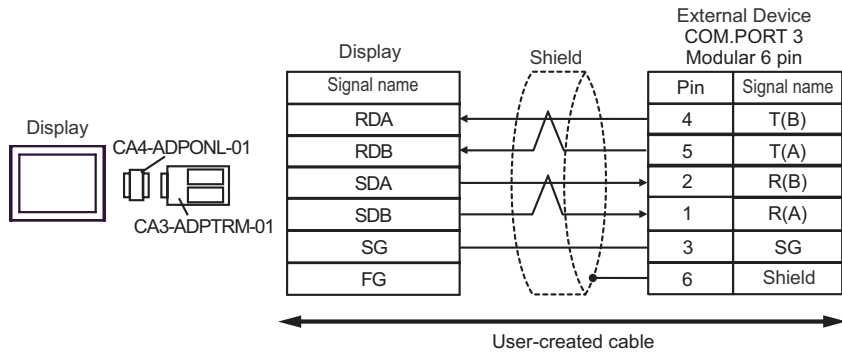

- 1:n Connection

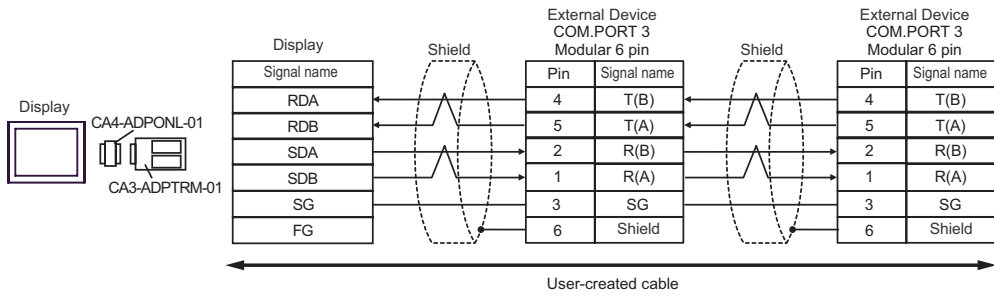

**NOTE** • Terminal resistance is not required.

6D)

- 1:1 Connection

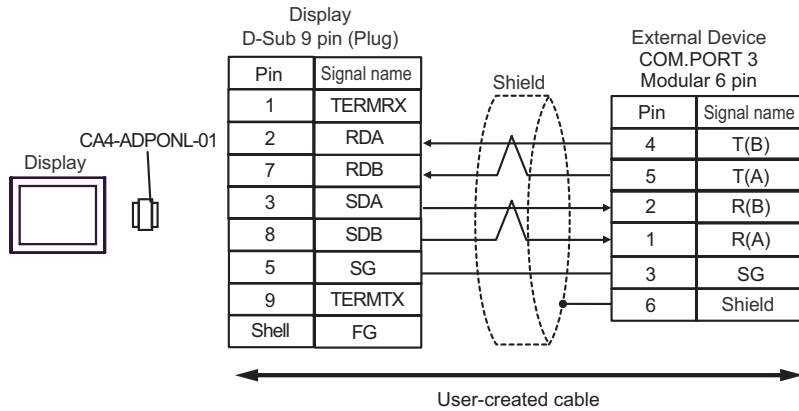

- 1:n Connection

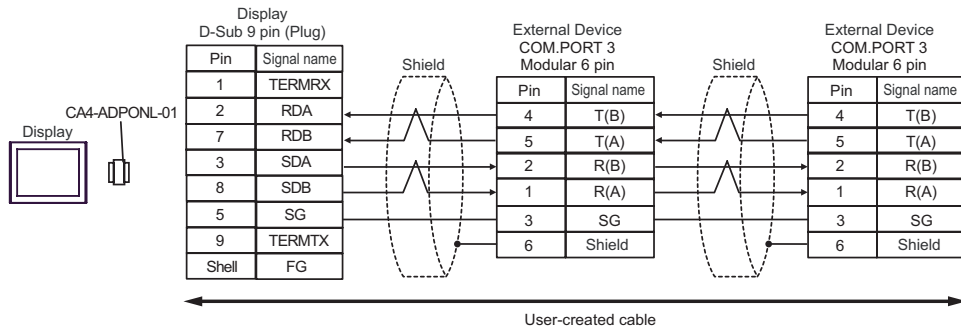

**NOTE** • Terminal resistance is not required.

6E)

- 1:1 Connection

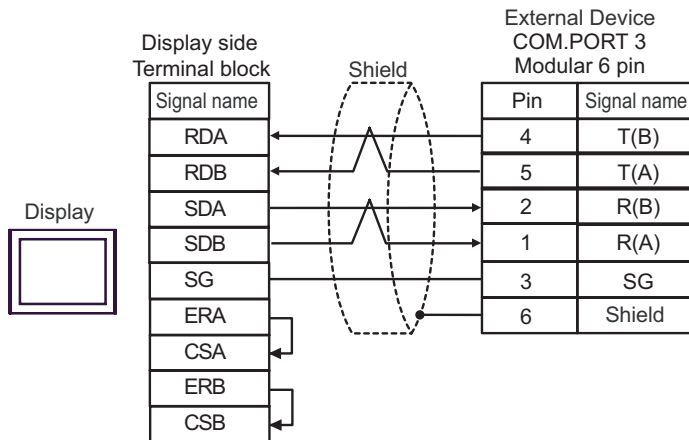

- 1:n Connection

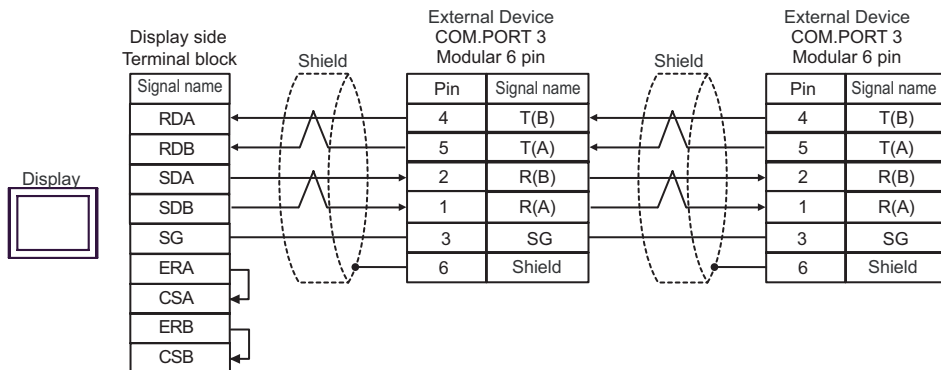

**NOTE** • Terminal resistance is not required.

6F)

- 1:1 Connection

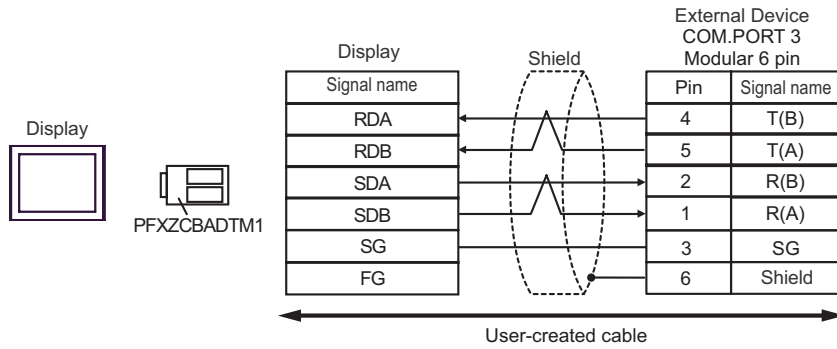

- 1:n Connection

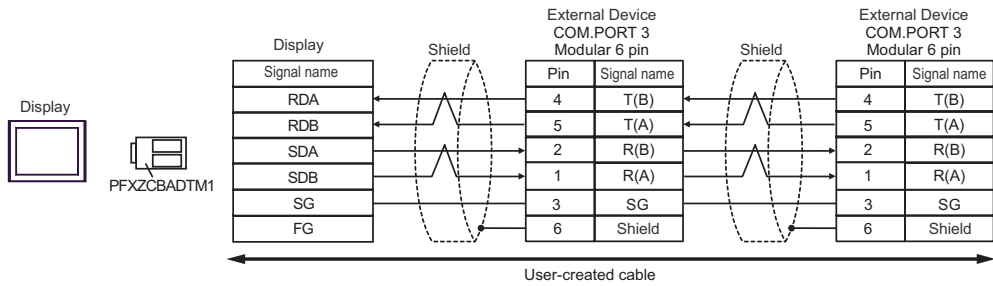

**NOTE** • Terminal resistance is not required.

Cable Diagram 7

Display (Connection Port)	Cable		Notes
GP3000* <sup>1</sup> (COM1) AGP-3302B (COM2) GP-4*01TM (COM1) ST* <sup>2</sup> (COM2) LT3000 (COM1)	7A	COM port conversion adapter by Pro-face CA3-ADPCOM-01 + Terminal block conversion adapter by Pro-face CA3-ADPTRM-01 + User-created cable	The cable length must be 1200m or less.
	7B	User-created cable	
GP3000* <sup>3</sup> (COM2)	7C	Online adapter by Pro-face CA4-ADPONL-01 + Terminal block conversion adapter by Pro-face CA3-ADPTRM-01 + User-created cable	
	7D	Online adapter by Pro-face CA4-ADPONL-01 + User-created cable	
IPC* <sup>4</sup>	7E	COM port conversion adapter by Pro-face CA3-ADPCOM-01 + Terminal block conversion adapter by Pro-face CA3-ADPTRM-01 + User-created cable	
	7F	User-created cable	
GP-4106 (COM1)	7G	User-created cable	
GP-4107 (COM1) GP-4*03T* <sup>5</sup> (COM2) GP-4203T (COM1)	7H	User-created cable	
GP4000* <sup>6</sup> (COM2) GP-4201T (COM1)	7I	RS-422 terminal block conversion adapter by Pro-face PFXZCBADTM1* <sup>7</sup> + User-created cable	
	7B	User-created cable	
LT-4*01TM (COM1)	7J	RJ45 RS-485 Cable (5m) by Pro-face PFXZLMCBRJR81	

\*1 All GP3000 models except AGP-3302B

\*2 All ST models except AST-3211A and AST-3302B

\*3 All GP3000 models except GP-3200 series and AGP-3302B

\*4 Only the COM port which can communicate by RS-422/485 (2 wire) can be used.

 ■ IPC COM Port (page 9)

\*5 Except GP-4203T

\*6 All GP4000 models except GP-4100 series, GP-4\*01TM, GP-4201T and GP-4\*03T

\*7 When using a Terminal Block Conversion Adapter (CA3-ADPTRM-01) instead of the RS-422 Terminal Block Conversion Adapter, refer to Cable Diagram 7A.



7A)

- 1:1 Connection

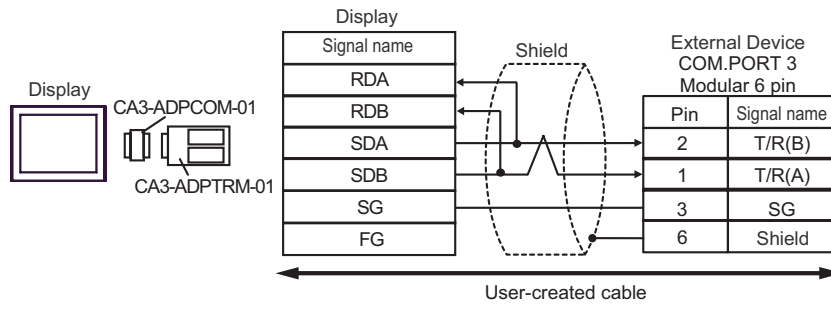

- 1:n Connection

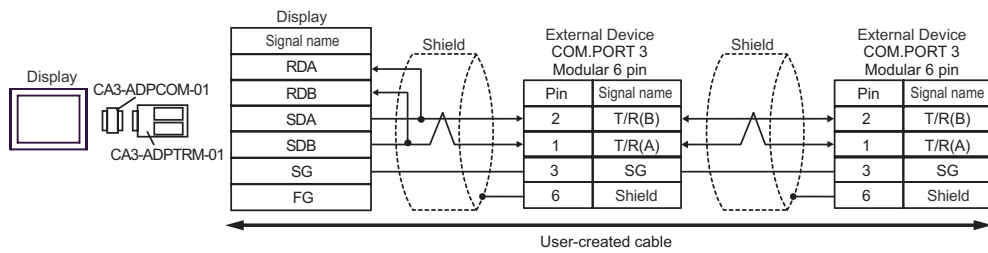

**NOTE** • Terminal resistance is not required.

7B)

- 1:1 Connection

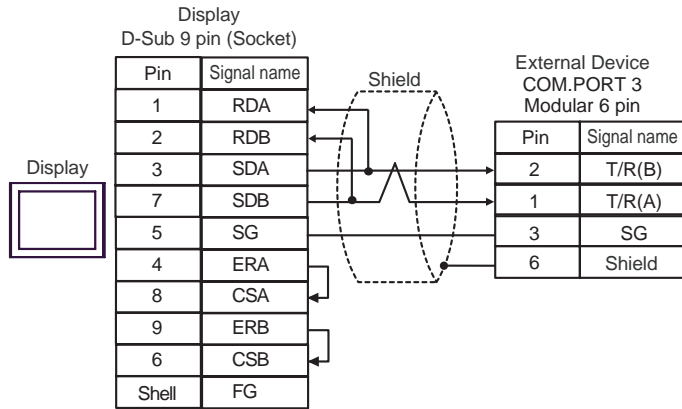

- 1:n Connection

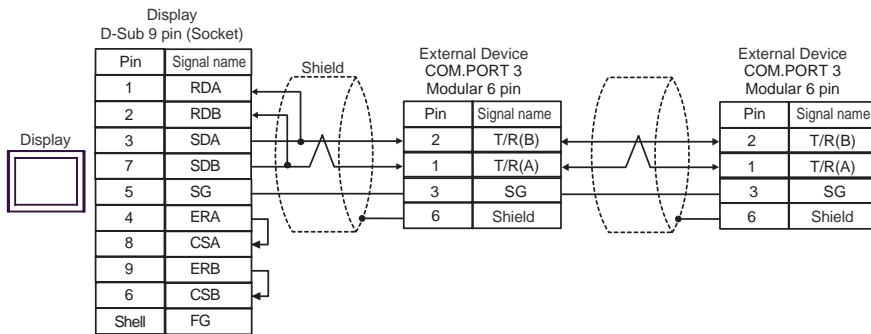

**NOTE** • Terminal resistance is not required.

7C)

- 1:1 Connection

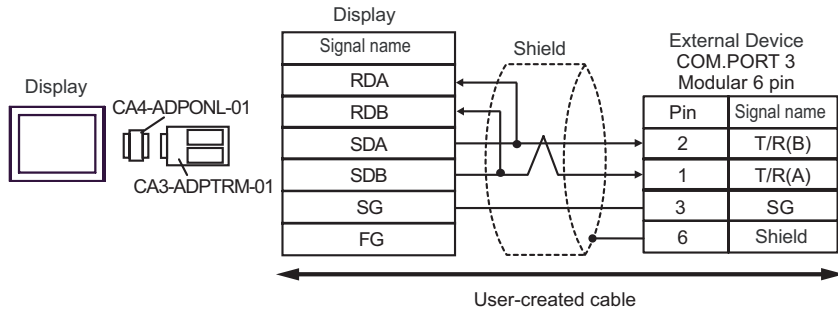

- 1:n Connection

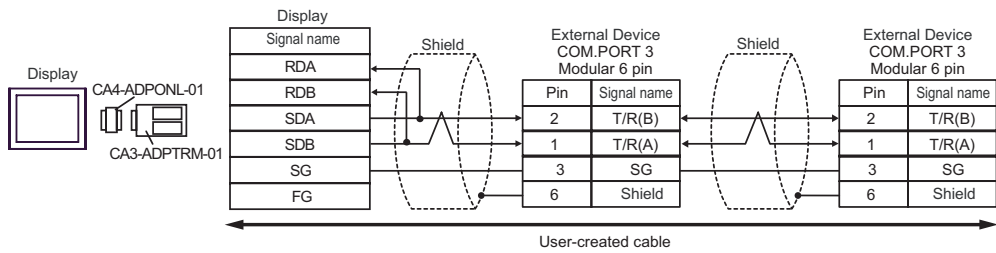

**NOTE**

- Terminal resistance is not required.

7D)

- 1:1 Connection

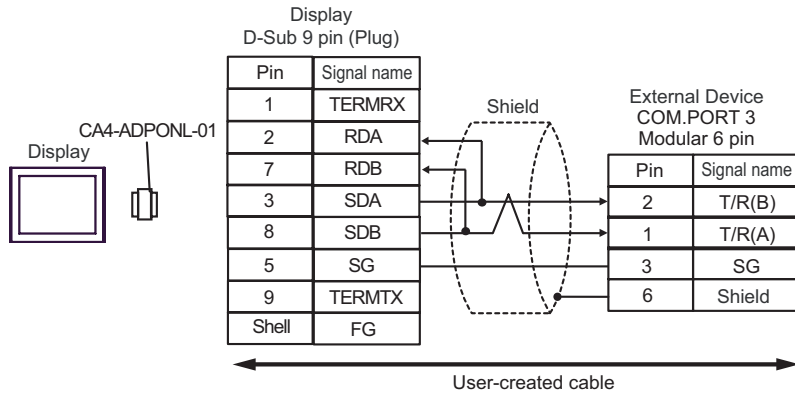

- 1:n Connection

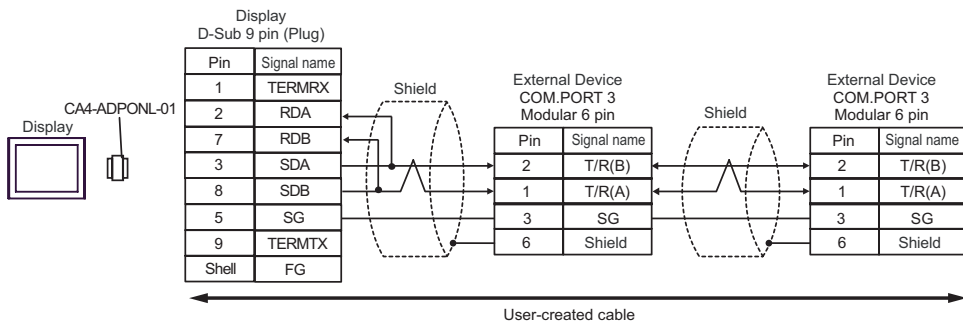

**NOTE** • Terminal resistance is not required.

7E)

- 1:1 Connection

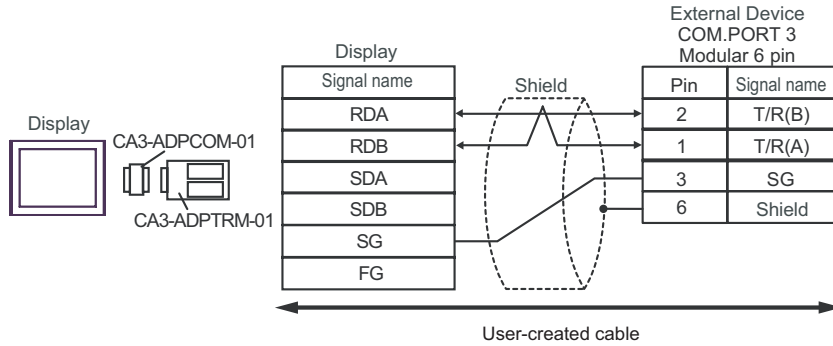

- 1:n Connection

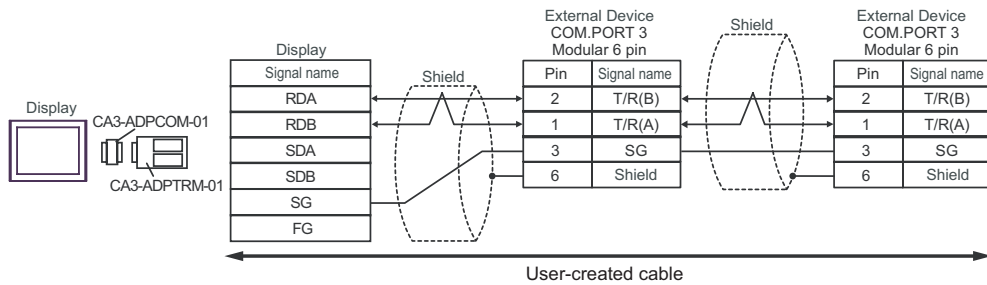

**NOTE** • Terminal resistance is not required.

7F)

- 1:1 Connection

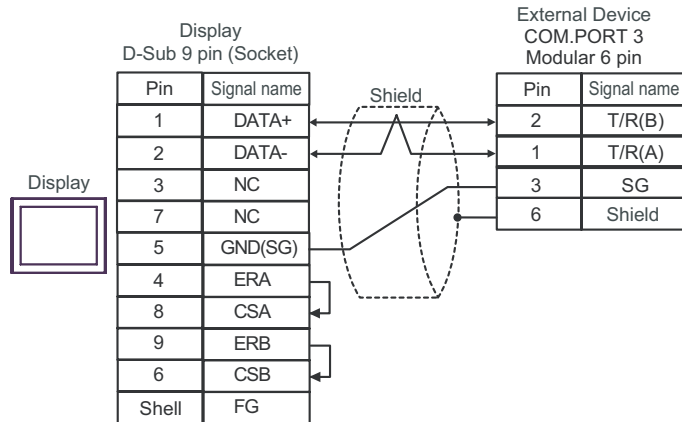

- 1:n Connection

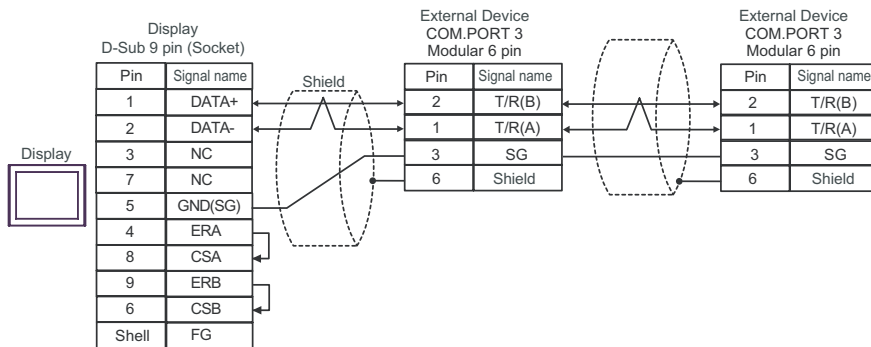

**NOTE** • Terminal resistance is not required.

7G)

- 1:1 Connection

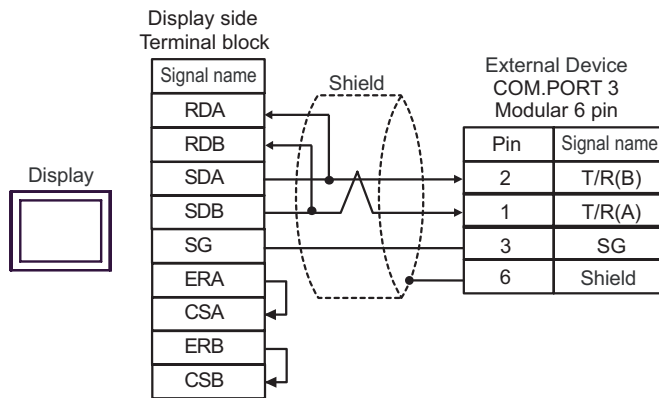

- 1:n Connection

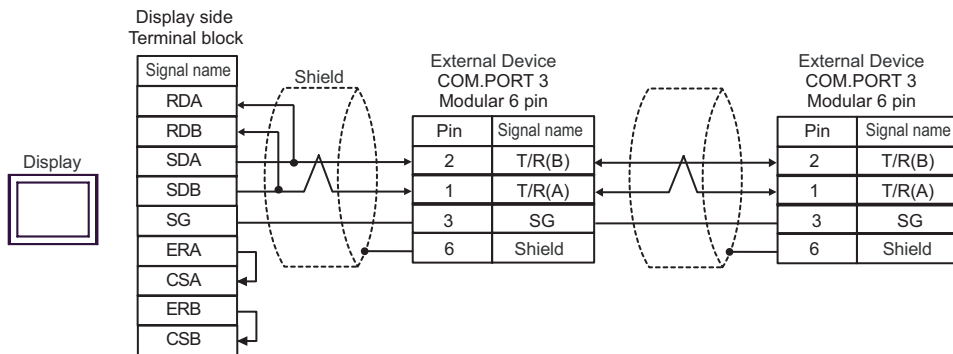

**NOTE** • Terminal resistance is not required.

7H)

- 1:1 Connection

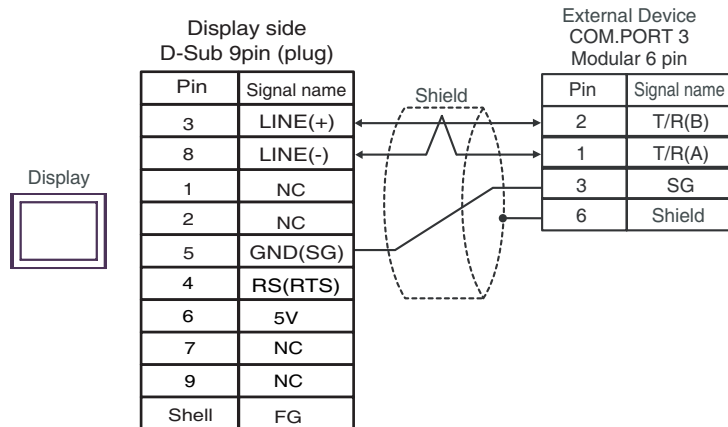

- 1:n Connection

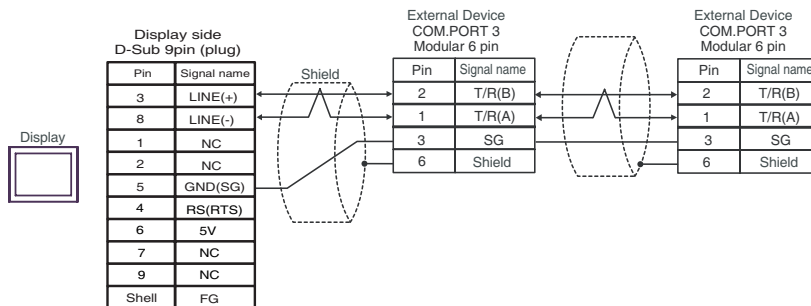

**IMPORTANT** • The 5V output (Pin #6) on the Display is the power for the Siemens AG's PROFIBUS connector. Do not use it for other devices.

**NOTE** • Terminal resistance is not required.  
 • In COM on the GP-4107, the SG and FG terminals are isolated.



7I)

- 1:1 Connection

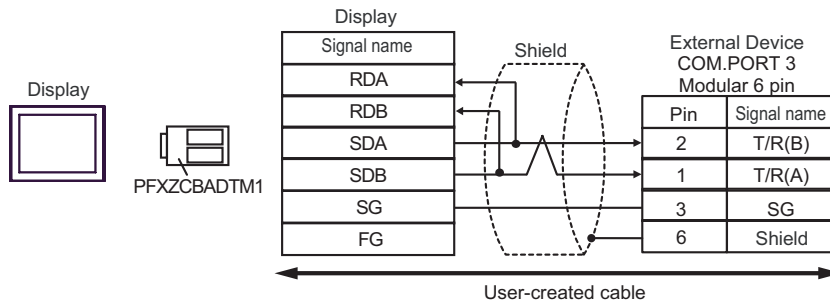

- 1:n Connection

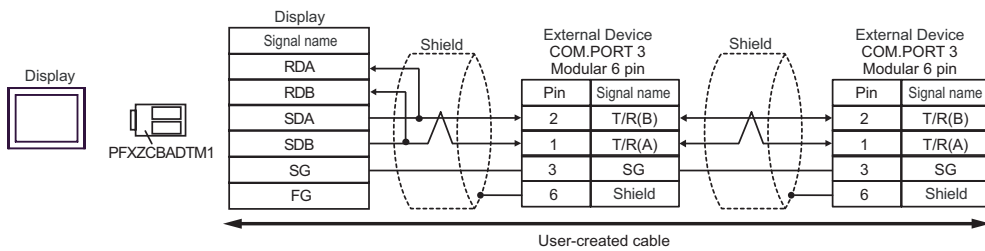

**NOTE** • Terminal resistance is not required.

7J)

- 1:1 Connection

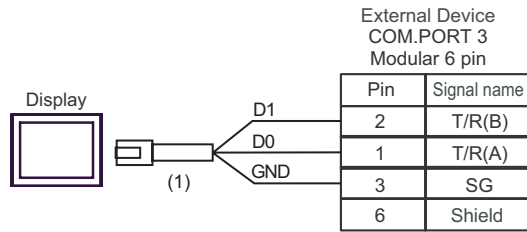

- 1:n Connection

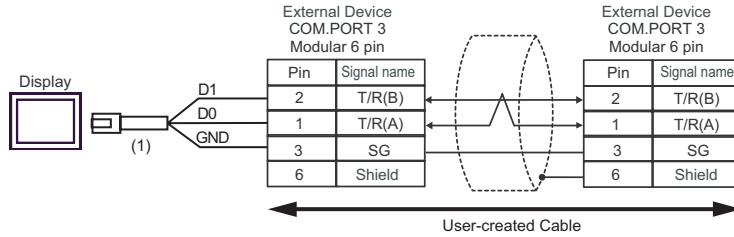

**NOTE**

- Terminal resistance is not required.

Number	Name	Notes
(1)	RJ45 RS-485 Cable (5m) by Pro-face PFXZLMCBRJR81	

Cable Diagram 8

Display (Connection Port)	Cable		Notes
GP3000* <sup>1</sup> (COM1) AGP-3302B (COM2) GP-4*01TM (COM1) ST* <sup>2</sup> (COM2) LT3000 (COM1) IPC* <sup>3</sup>	8A	COM port conversion adapter by Pro-face CA3-ADPCOM-01 + Terminal block conversion adapter by Pro-face CA3-ADPTRM-01 + User-created cable	The cable length must be 1200m or less.
	8B	User-created cable	
GP3000* <sup>4</sup> (COM2)	8C	Online adapter by Pro-face CA4-ADPONL-01 + Terminal block conversion adapter by Pro-face CA3-ADPTRM-01 + User-created cable	
	8D	Online adapter by Pro-face CA4-ADPONL-01 + User-created cable	
GP-4106 (COM1)	8E	User-created cable	
GP4000* <sup>5</sup> (COM2) GP-4201T (COM1)	8F	RS-422 terminal block conversion adapter by Pro-face PFXZCBADTM1* <sup>6</sup> + User-created cable	
	8B	User-created cable	

\*1 All GP3000 models except AGP-3302B

\*2 All ST models except AST-3211A and AST-3302B

\*3 Only the COM port which can communicate by RS-422/485 (4 wire) can be used.

 ■ IPC COM Port (page 9)

\*4 All GP3000 models except GP-3200 series and AGP-3302B

\*5 All GP4000 models except GP-4100 series, GP-4\*01TM, GP-4201T and GP-4\*03T

\*6 When using a Terminal Block Conversion Adapter (CA3-ADPTRM-01) instead of the RS-422 Terminal Block Conversion Adapter, refer to Cable Diagram 8A.

8A)

- 1:1 Connection

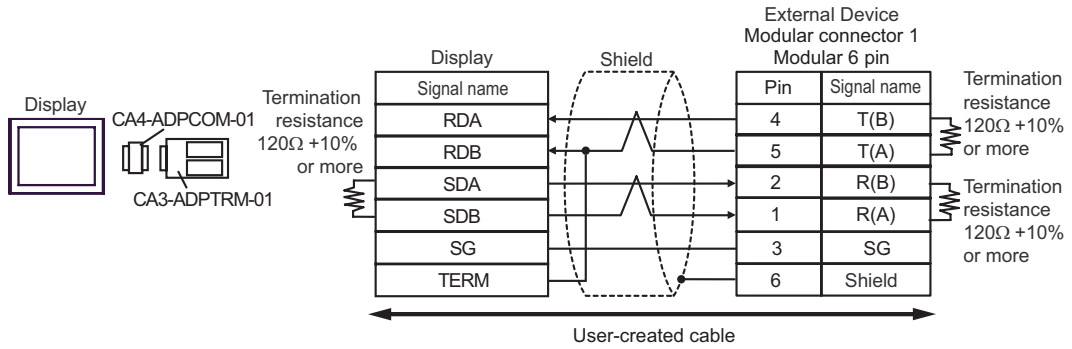

- 1:n Connection

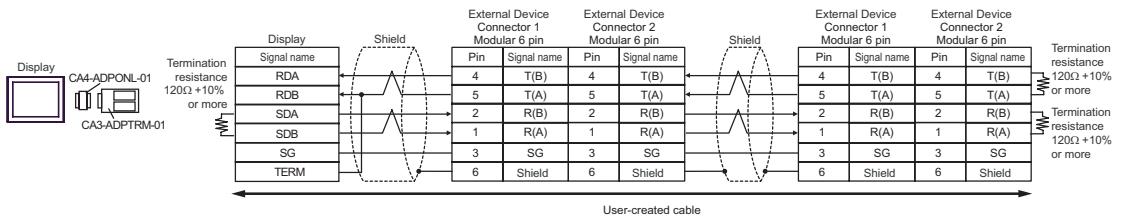

8B)

- 1:1 Connection

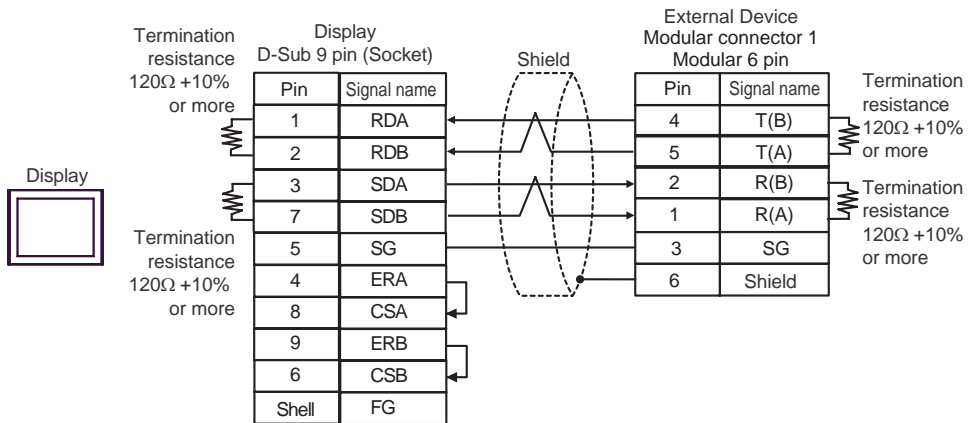

- 1:n Connection

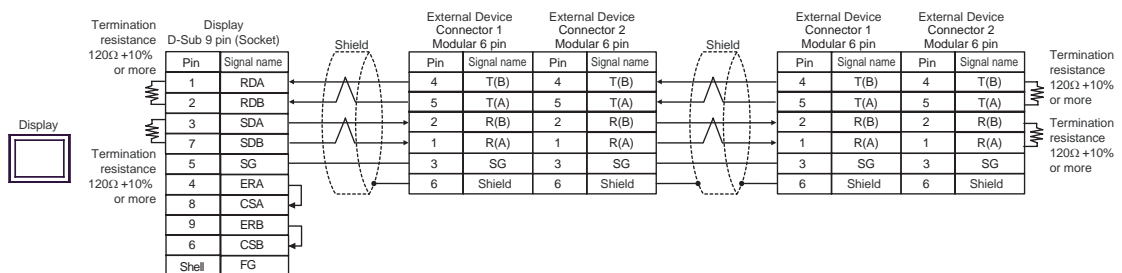

8C)

- 1:1 Connection

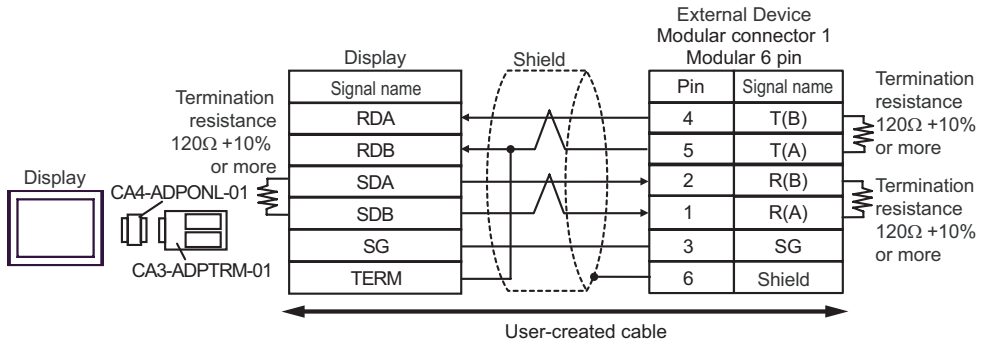

- 1:n Connection

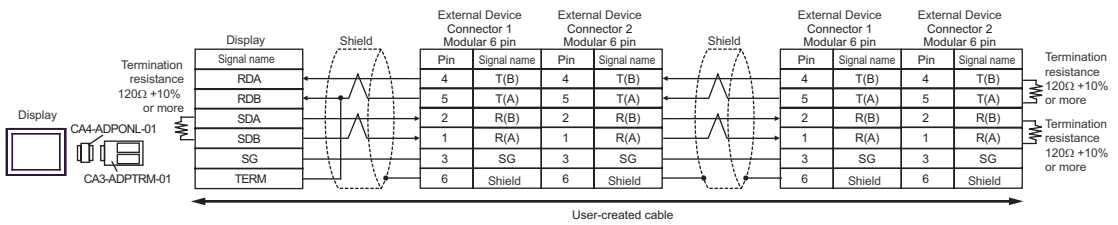

8D)

- 1:1 Connection

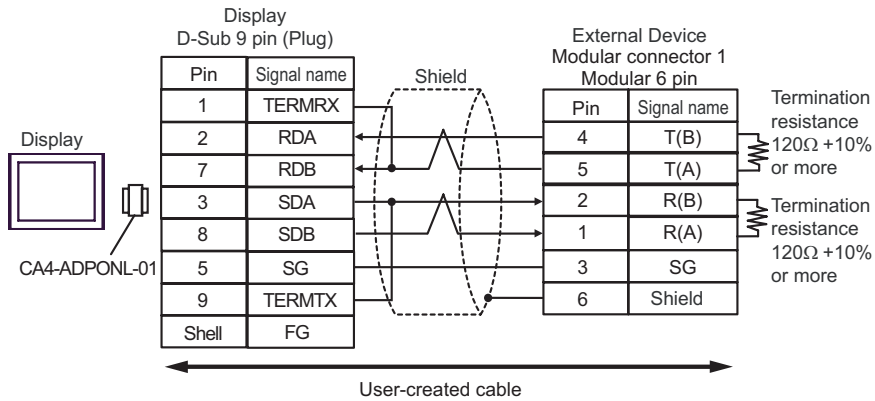

- 1:n Connection

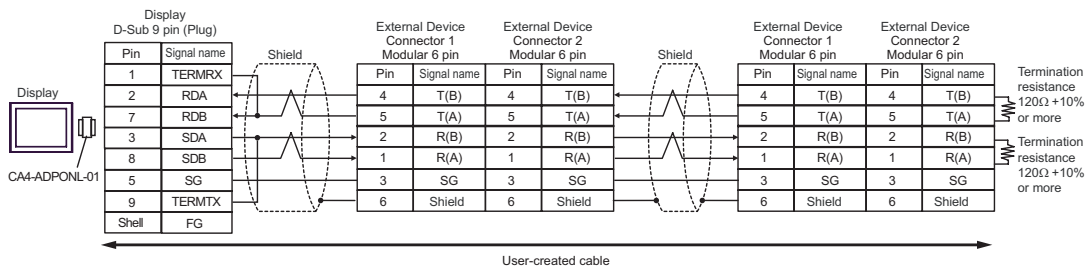

8E)

- 1:1 Connection

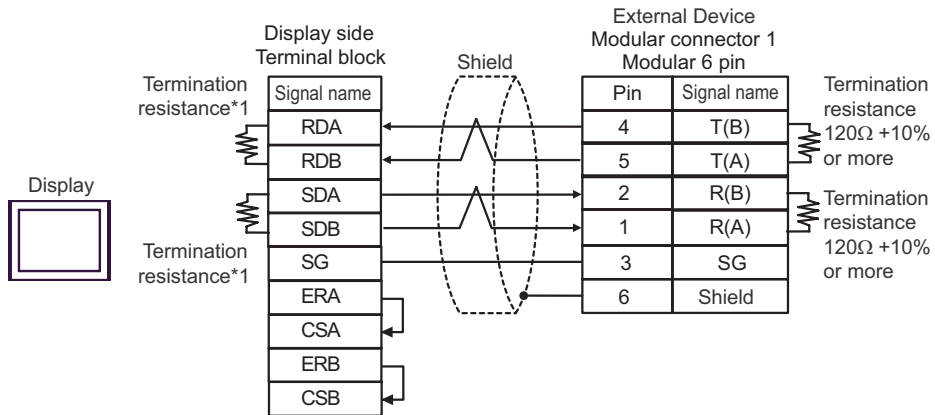

- 1:n Connection

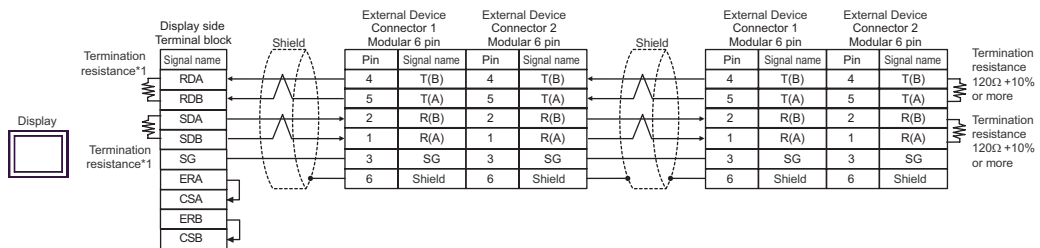

\*1 The resistance in the Display is used as the termination resistance. Set the value of the DIP Switch on the rear of the Display as shown in the table below.

DIP Switch No.	Set Value
1	ON
2	ON
3	ON
4	ON

8F)

- 1:1 Connection

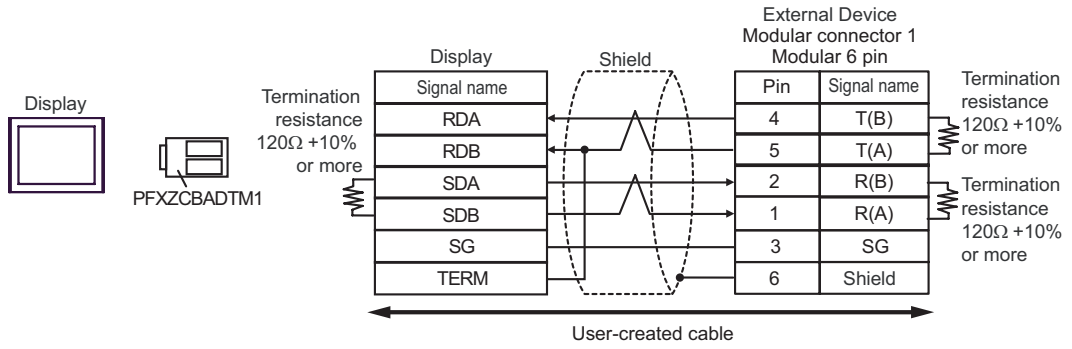

- 1:n Connection

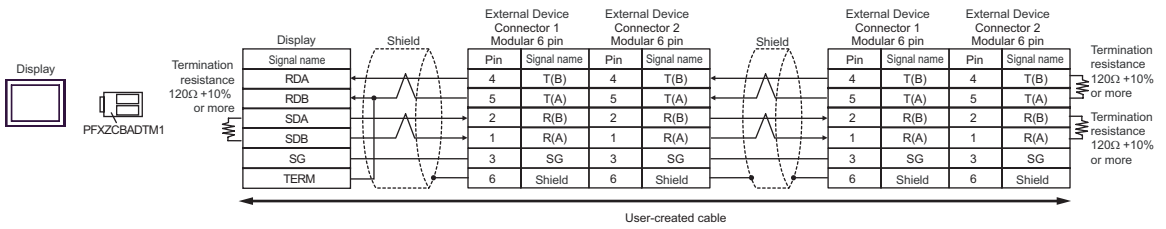

Cable Diagram 9

Display (Connection Port)	Cable		Notes
GP3000* <sup>1</sup> (COM1) AGP-3302B (COM2) GP-4*01TM (COM1) ST* <sup>2</sup> (COM2) LT3000 (COM1)	9A	COM port conversion adapter by Pro-face CA3-ADPCOM-01 + Terminal block conversion adapter by Pro-face CA3-ADPTRM-01 + User-created cable	The cable length must be 1200m or less.
	9B	User-created cable	
GP3000* <sup>3</sup> (COM2)	9C	Online adapter by Pro-face CA4-ADPONL-01 + Terminal block conversion adapter by Pro-face CA3-ADPTRM-01 + User-created cable	
	9D	Online adapter by Pro-face CA4-ADPONL-01 + User-created cable	
IPC* <sup>4</sup>	9E	COM port conversion adapter by Pro-face CA3-ADPCOM-01 + Terminal block conversion adapter by Pro-face CA3-ADPTRM-01 + User-created cable	
	9F	User-created cable	
GP-4106 (COM1)	9G	User-created cable	
GP-4107 (COM1) GP-4*03T* <sup>5</sup> (COM2) GP-4203T (COM1)	9H	User-created cable	
GP4000* <sup>6</sup> (COM2) GP-4201T (COM1)	9I	RS-422 terminal block conversion adapter by Pro-face PFXZCBADTM1* <sup>7</sup> + User-created cable	
	9B	User-created cable	
LT-4*01TM (COM1)	9J	RJ45 RS-485 Cable (5m) by Pro-face PFXZLMCBRJR81	

\*1 All GP3000 models except AGP-3302B

\*2 All ST models except AST-3211A and AST-3302B

\*3 All GP3000 models except GP-3200 series and AGP-3302B

\*4 Only the COM port which can communicate by RS-422/485 (2 wire) can be used.

 ■ IPC COM Port (page 9)

\*5 Except GP-4203T

\*6 All GP4000 models except GP-4100 series, GP-4\*01TM, GP-4201T and GP-4\*03T

\*7 When using a Terminal Block Conversion Adapter (CA3-ADPTRM-01) instead of the RS-422 Terminal Block Conversion Adapter, refer to Cable Diagram 9A.



9A)

- 1:1 Connection

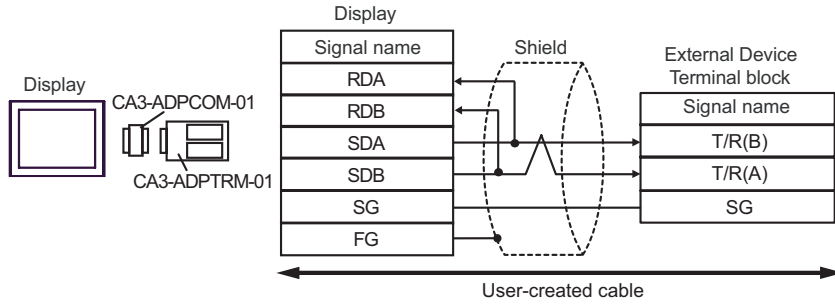

- 1:n Connection

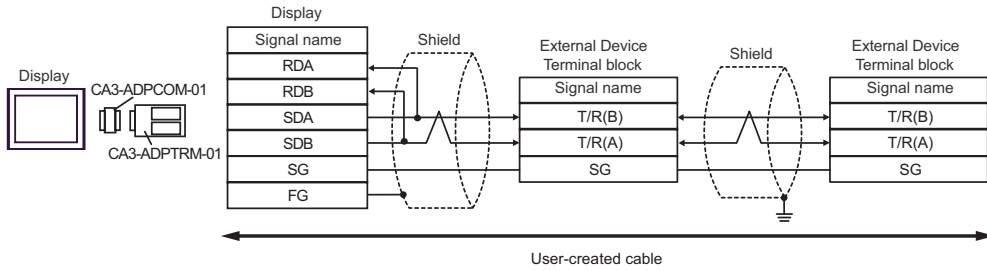

9B)

- 1:1 Connection

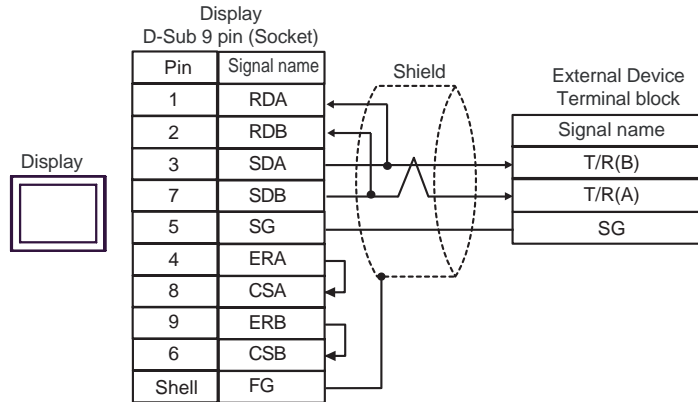

- 1:n Connection

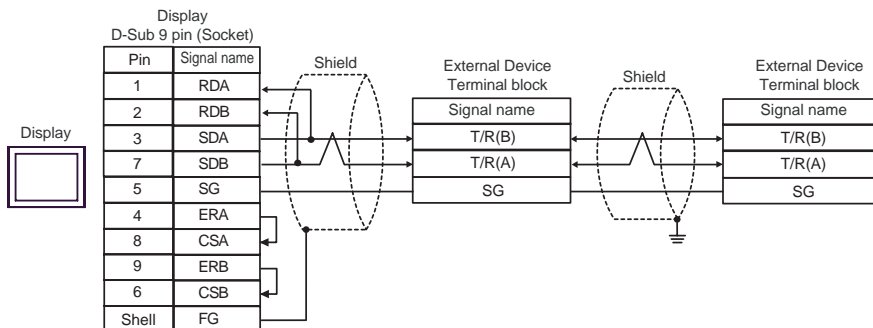

9C)

- 1:1 Connection

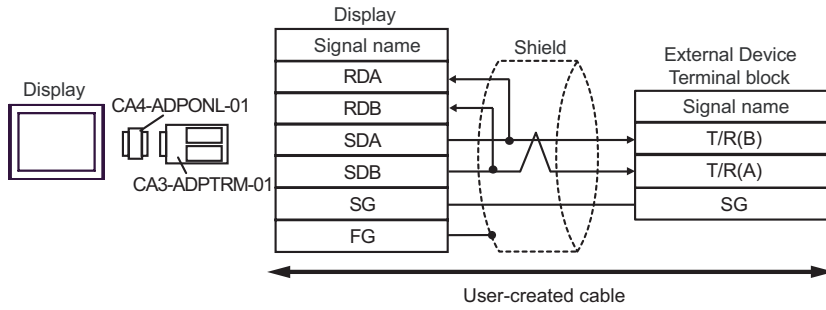

- 1:n Connection

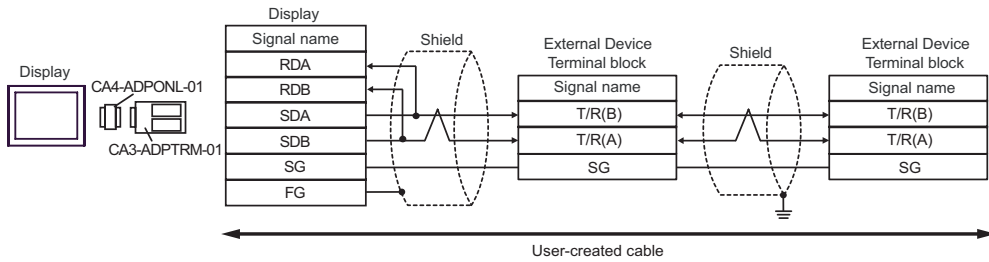

9D)

- 1:1 Connection

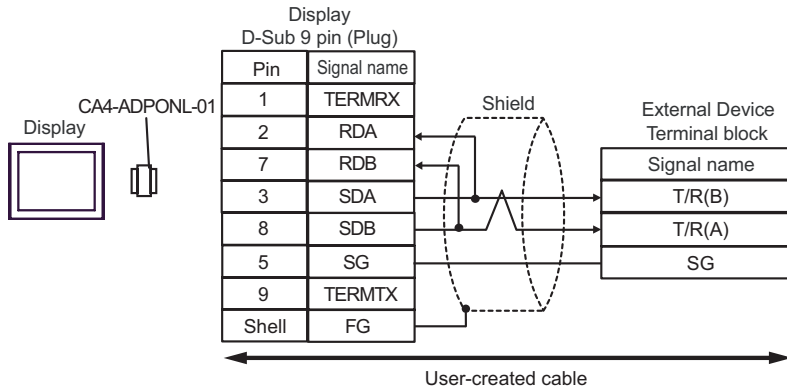

- 1:n Connection

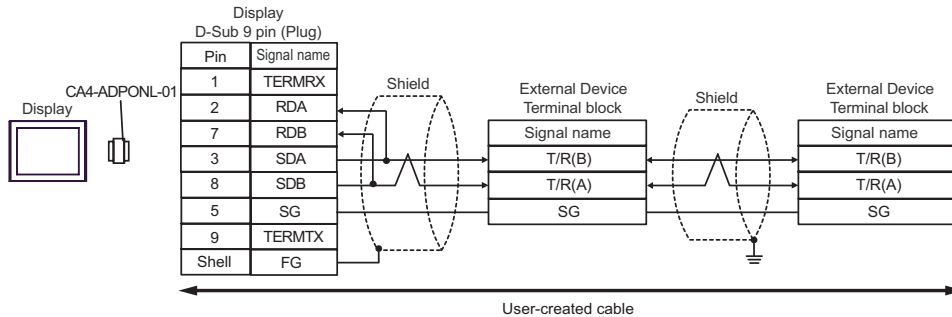

9E)

- 1:1 Connection

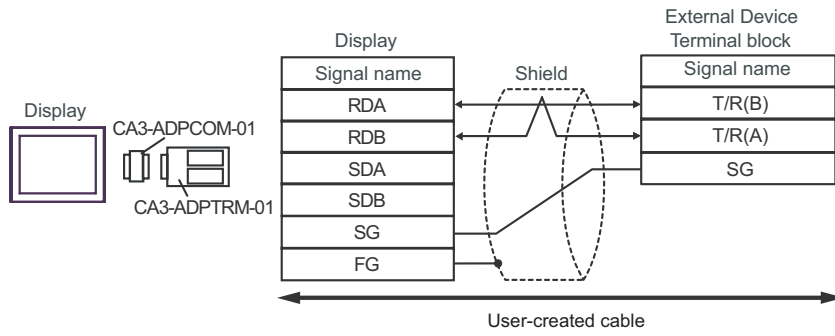

- 1:n Connection

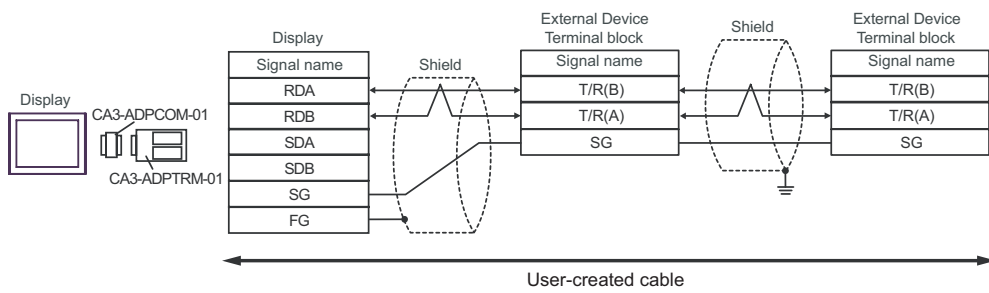

9F)

- 1:1 Connection

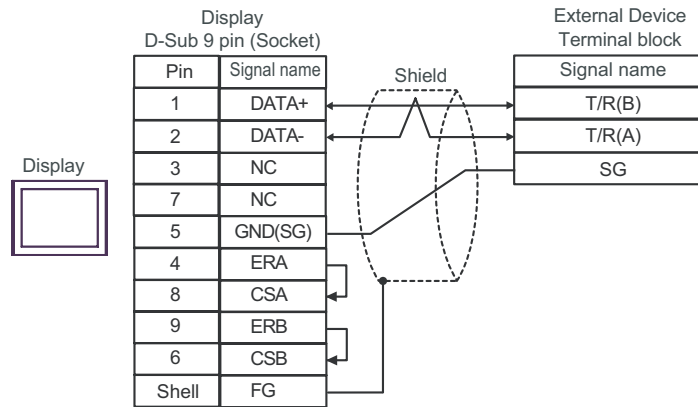

- 1:n Connection

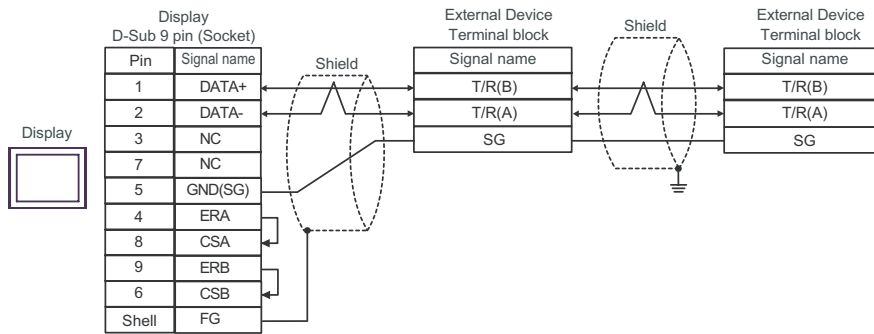

9G)

- 1:1 Connection

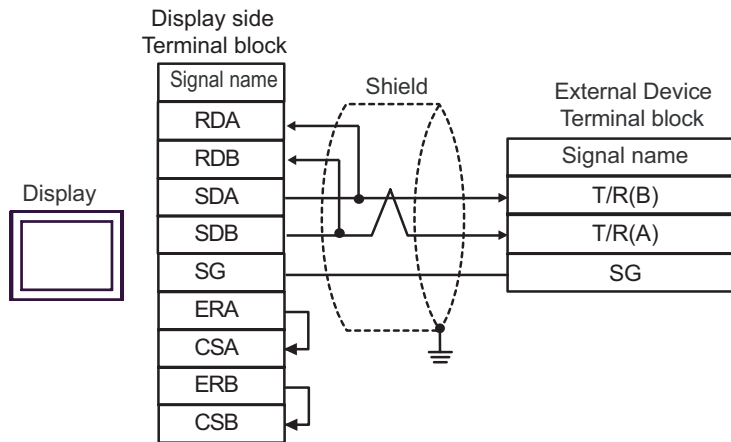

- 1:n Connection

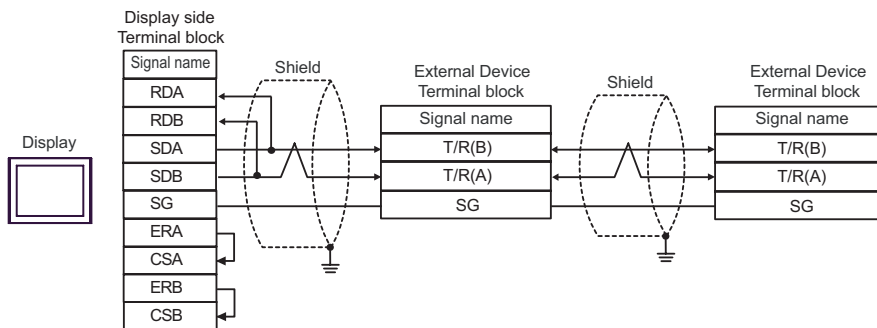

9H)

- 1:1 Connection

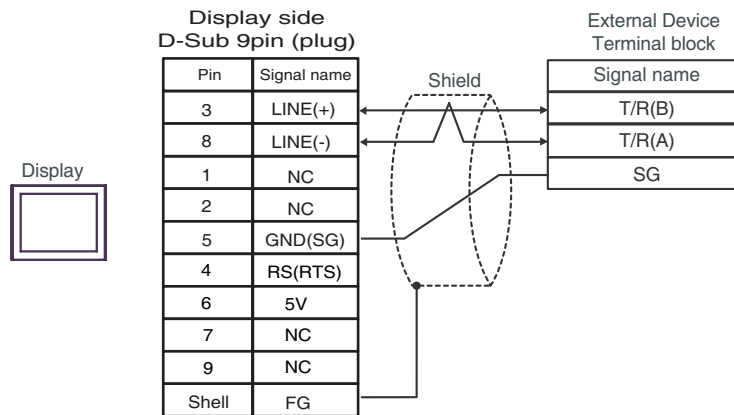

- 1:n Connection

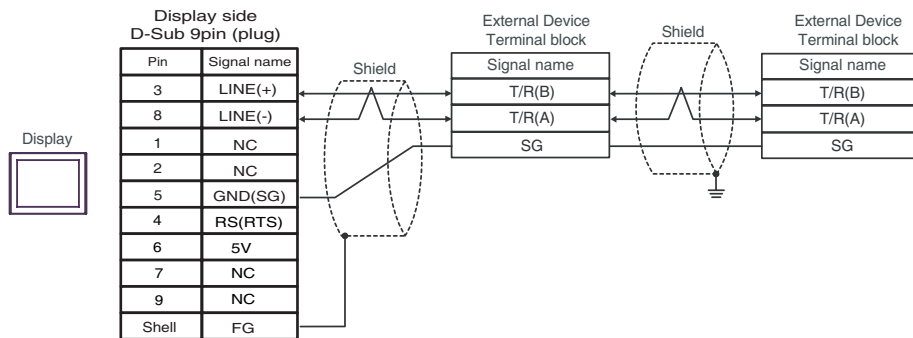

**IMPORTANT** • The 5V output (Pin #6) on the Display is the power for the Siemens AG's PROFIBUS connector. Do not use it for other devices.

**NOTE** • In COM on the GP-4107, the SG and FG terminals are isolated.

9I)

- 1:1 Connection

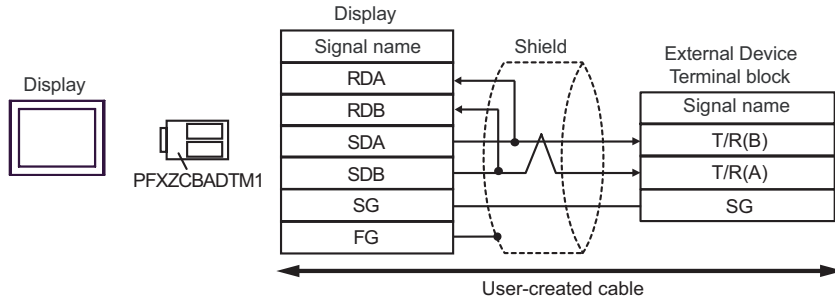

- 1:n Connection

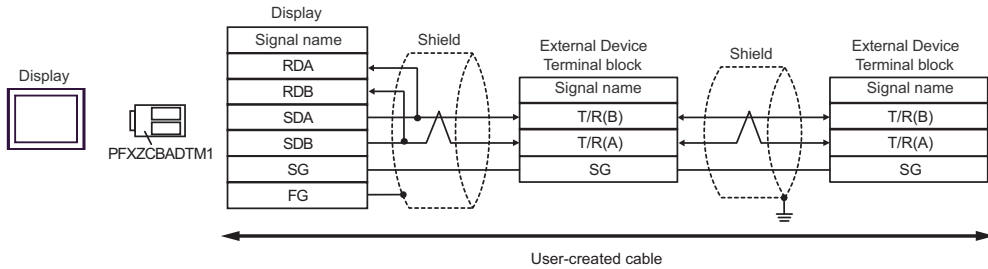

9J)

- 1:1 Connection

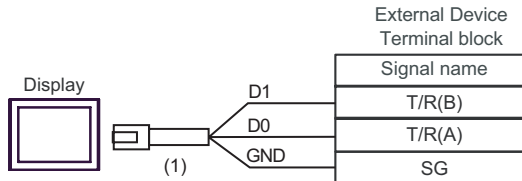

- 1:n Connection

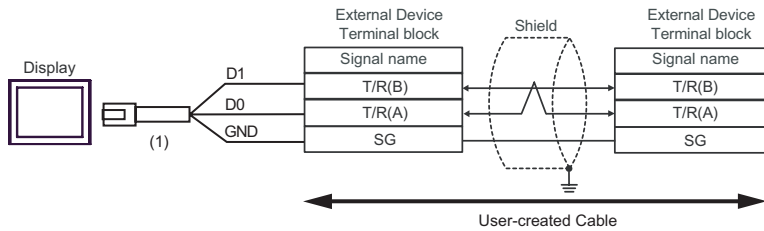

Number	Name	Notes
(1)	RJ45 RS-485 Cable (5m) by Pro-face PFXZLMCBRJ81	

Cable Diagram 10

Display (Connection Port)	Cable		Notes
GP3000 <sup>*1</sup> (COM1) AGP-3302B (COM2) GP-4*01TM (COM1) ST <sup>*2</sup> (COM2) LT3000 (COM1) IPC <sup>*3</sup>	10A	COM port conversion adapter by Pro-face CA3-ADPCOM-01 + Terminal block conversion adapter by Pro-face CA3-ADPTRM-01 + User-created cable	The cable length must be 1200m or less.
	10B	User-created cable	
GP3000 <sup>*4</sup> (COM2)	10C	Online adapter by Pro-face CA4-ADPONL-01 + Terminal block conversion adapter by Pro-face CA3-ADPTRM-01 + User-created cable	
	10D	Online adapter by Pro-face CA4-ADPONL-01 + User-created cable	
GP-4106 (COM1)	10E	User-created cable	
GP4000 <sup>*5</sup> (COM2) GP-4201T (COM1)	10F	RS-422 terminal block conversion adapter by Pro-face PFXZCBADTM1 <sup>*6</sup> + User-created cable	
	10B	User-created cable	

\*1 All GP3000 models except AGP-3302B

\*2 All ST models except AST-3211A and AST-3302B

\*3 Only the COM port which can communicate by RS-422/485 (4 wire) can be used.

 ■ IPC COM Port (page 9)

\*4 All GP3000 models except GP-3200 series and AGP-3302B

\*5 All GP4000 models except GP-4100 series, GP-4\*01TM, GP-4201T and GP-4\*03T

\*6 When using a Terminal Block Conversion Adapter (CA3-ADPTRM-01) instead of the RS-422 Terminal Block Conversion Adapter, refer to Cable Diagram 10A.



10A)

- 1:1 Connection

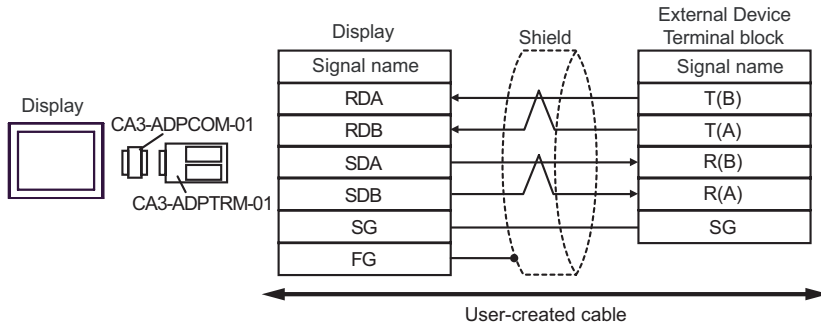

- 1:n Connection

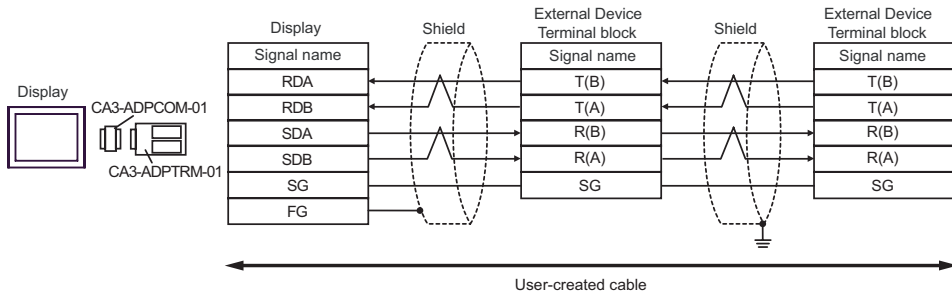

10B)

- 1:1 Connection

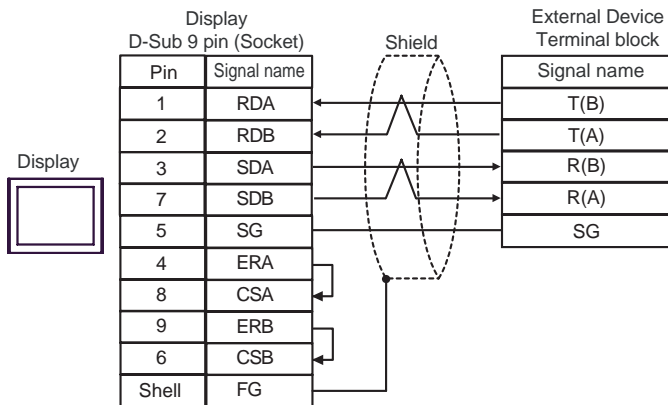

- 1:n Connection

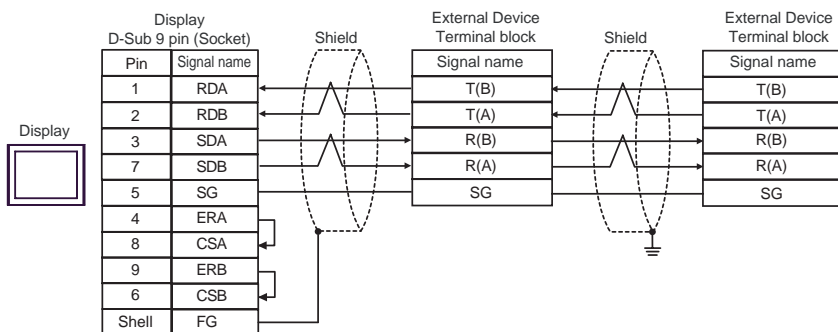

10C)

- 1:1 Connection

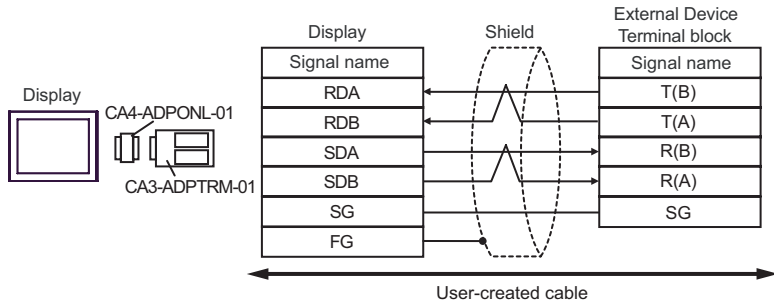

- 1:n Connection

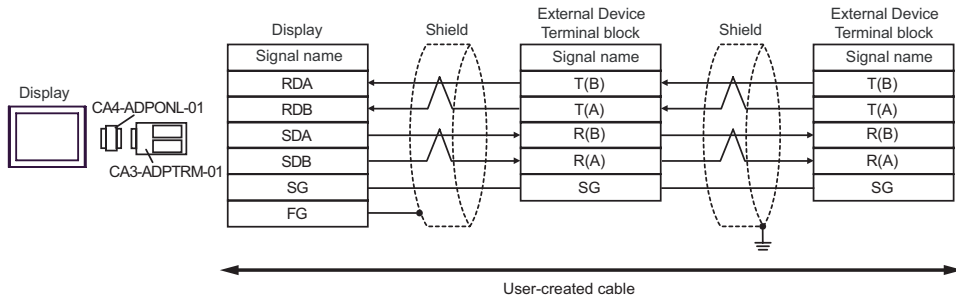

10D)

- 1:1 Connection

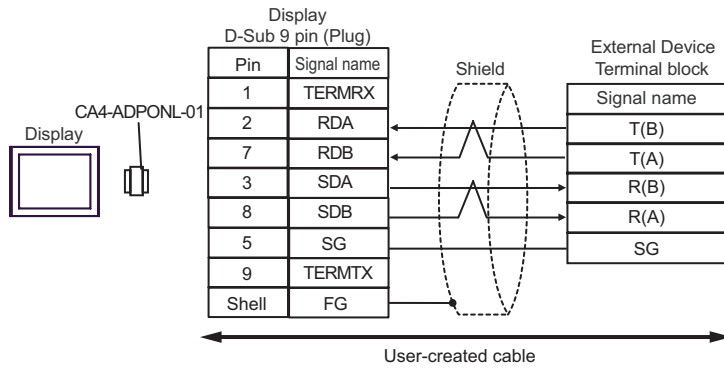

- 1:n Connection

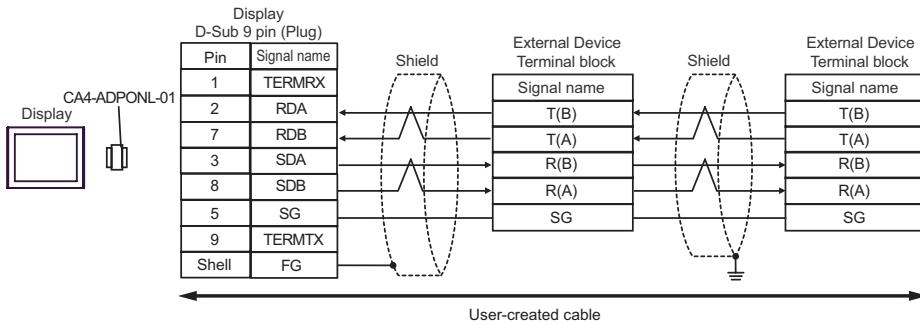

10E)

- 1:1 Connection

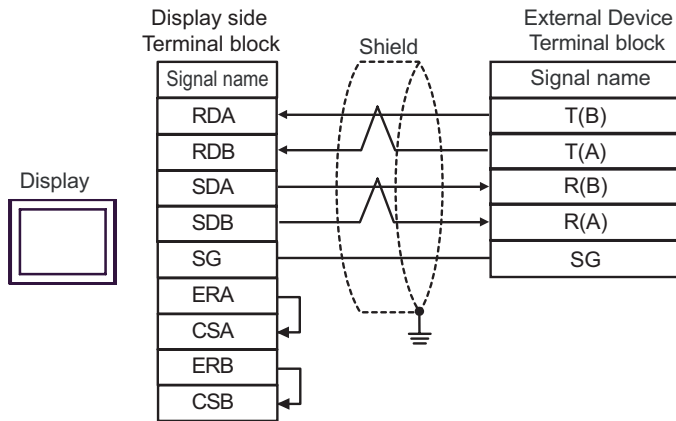

- 1:n Connection

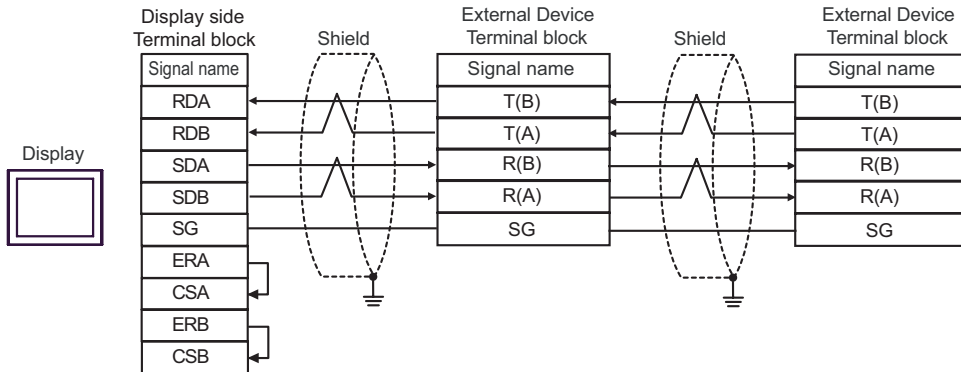

10F)

- 1:1 Connection

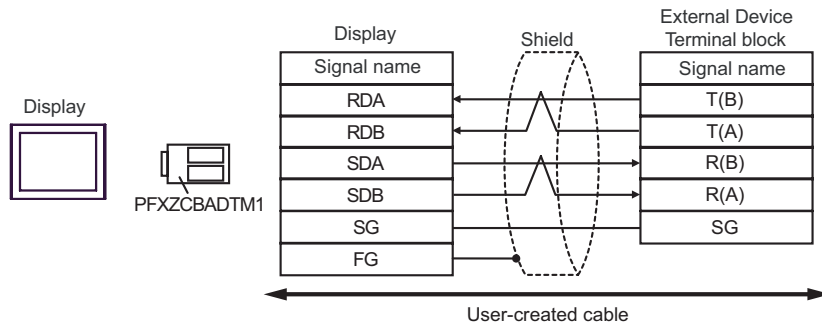

- 1:n Connection

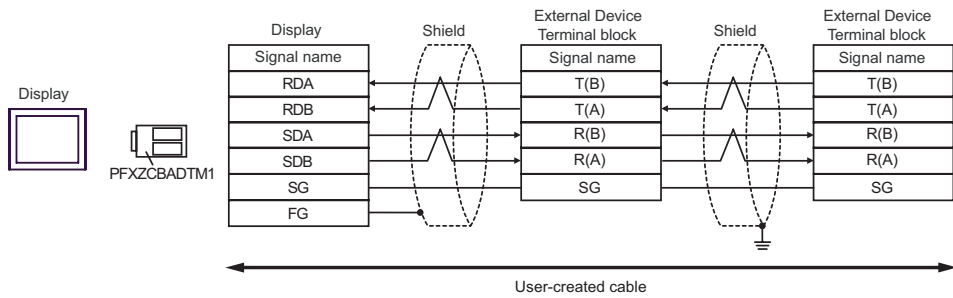

Cable Diagram 11

Display (Connection Port)	Cable		Notes
GP3000 (COM1) GP4000* <sup>1</sup> (COM1) ST (COM1) LT3000 (COM1) IPC* <sup>2</sup> PC/AT	11A	User-created cable	The cable length must be 15m or less.
GP-4105 (COM1)	11B	User-created cable	
LT-4*01TM (COM1)	11C	RJ45 RS-232C Cable (5m) by Pro-face PFXZLMCBRJ21	

\*1 All GP4000 models except GP-4100 series and GP-4203T

\*2 Only the COM port which can communicate by RS-232C can be used.

 ■ IPC COM Port (page 9)

11A)

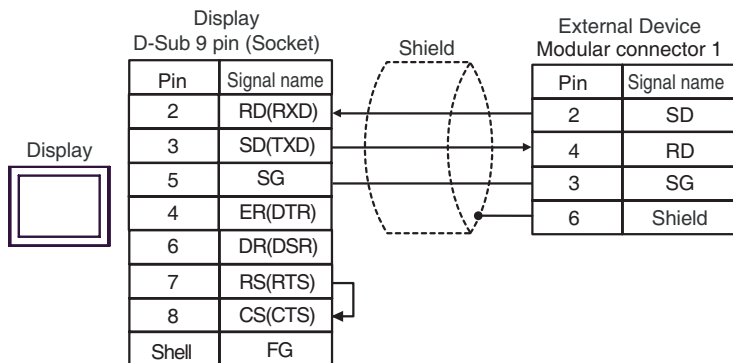

11B)

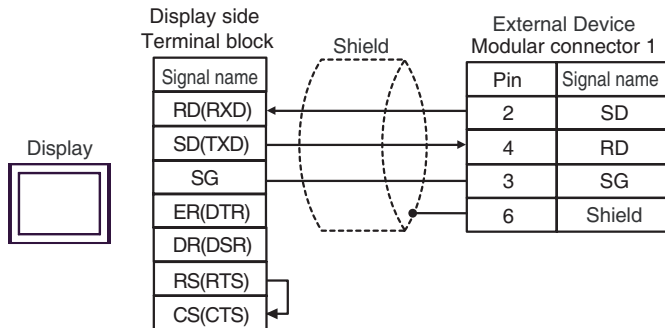

11C)

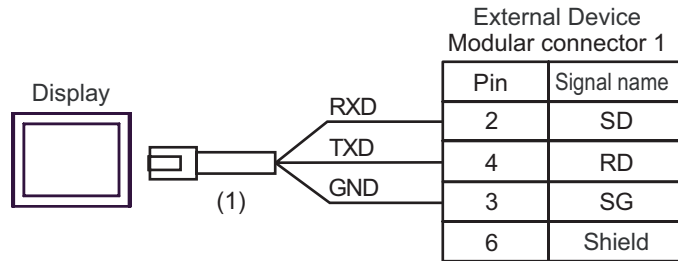

Number	Name	Notes
(1)	RJ45 RS-232C Cable (5m) by Pro-face PFXZLMCBRJ21	

Cable Diagram 12

Display (Connection Port)	Cable		Notes
GP3000 (COM1) GP4000* <sup>1</sup> (COM1) ST (COM1) LT3000 (COM1) IPC* <sup>2</sup> PC/AT	12A	User-created cable	The cable length must be 15m or less.
GP-4105 (COM1)	12B	User-created cable	
LT-4*0ITM (COM1)	12C	RJ45 RS-232C Cable (5m) by Pro-face PFXZLMCBRJ21	

\*1 All GP4000 models except GP-4100 Series and GP-4203T

\*2 Only the COM port which can communicate by RS-232C can be used.

 ■ IPC COM Port (page 9)

12A)

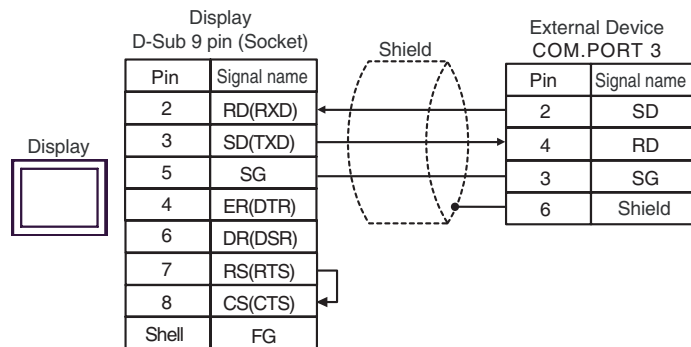

12B)

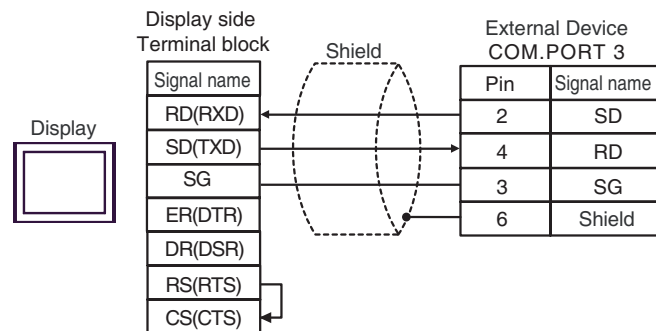

12C)

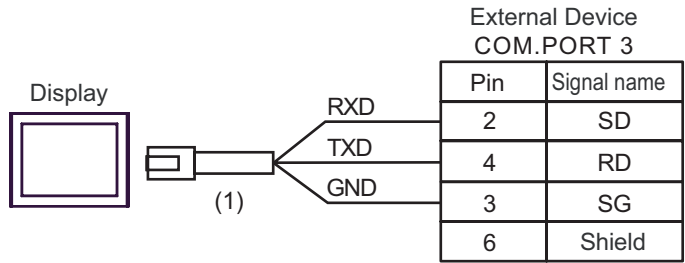

Number	Name	Notes
(1)	RJ45 RS-232C Cable (5m) by Pro-face PFXZLMCBJR21	



Cable Diagram 13

Display (Connection Port)	Cable		Remarks
GP3000* <sup>1</sup> (COM1) AGP-3302B (COM2) GP-4*01TM (COM1) ST* <sup>2</sup> (COM2) LT3000 (COM1)	13A	COM port conversion adapter by Pro-face CA3-ADPCOM-01 + Terminal block conversion adapter by Pro-face CA3-ADPTRM-01 + User-created cable	Cable length: 1200m or less
	13B	User-created cable	
GP3000* <sup>3</sup> (COM2)	13C	Online adapter by Pro-face CA4-ADPONL-01 + Terminal block conversion adapter by Pro-face CA3-ADPTRM-01 + User-created cable	
	13D	Online adapter by Pro-face CA4-ADPONL-01 + User-created cable	
IPC* <sup>4</sup>	13E	COM port conversion adapter by Pro-face CA3-ADPCOM-01 + Terminal block conversion adapter by Pro-face CA3-ADPTRM-01 + User-created cable	
	13F	User-created cable	
GP-4106 (COM1)	13G	User-created cable	
GP-4107 (COM1) GP-4*03T* <sup>5</sup> (COM2) GP-4203T (COM1)	13H	User-created cable	
GP4000* <sup>6</sup> (COM2) GP-4201T (COM1)	13I	RS-422 terminal block conversion adapter by Pro-face PFXZCBADTM1* <sup>7</sup> + User-created cable	
	13B	User-created cable	
LT-4*01TM (COM1)	13J	RJ45 RS-485 Cable (5m) by Pro-face PFXZLMCBJR81	

\*1 All GP3000 models except AGP-3302B

\*2 All ST models except AST-3211A and AST-3302B

\*3 All GP3000 models except GP-3200 and AGP-3302B

\*4 Only the COM port which can communicate by RS-422/485 (2wire) can be used.

 ■ IPC COM Port (page 9)

\*5 Except GP-4203T

\*6 All GP4000 models except GP-4100 series, GP-4\*01TM, GP-4201T and GP-4\*03T

\*7 When using a Terminal Block Conversion Adapter (CA3-ADPTRM-01) instead of the RS-422 Terminal Block Conversion Adapter, refer to Cable Diagram 13A.

13A)

- 1:1 Connection

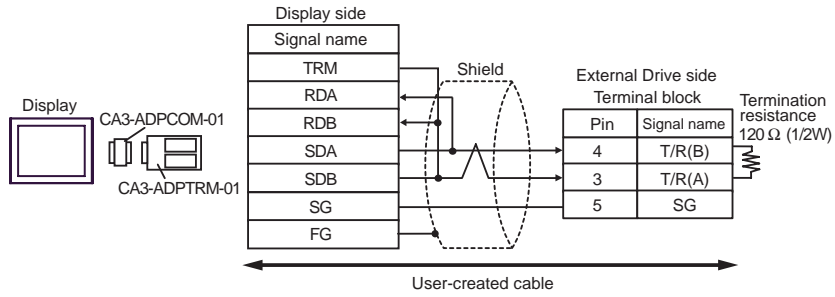

- 1:n Connection (When connecting with the internal communication line)

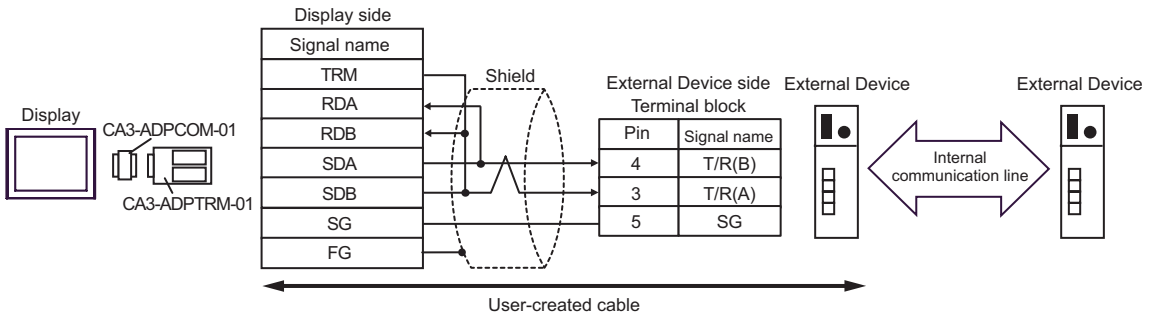

- 1:n Connection

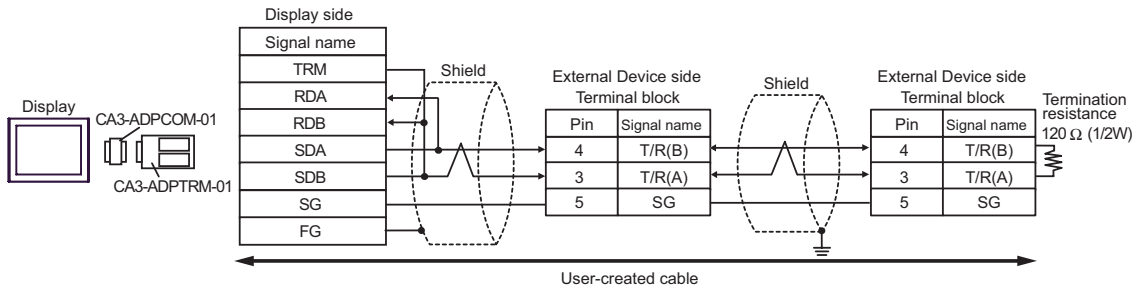

13B)

- 1:1 Connection

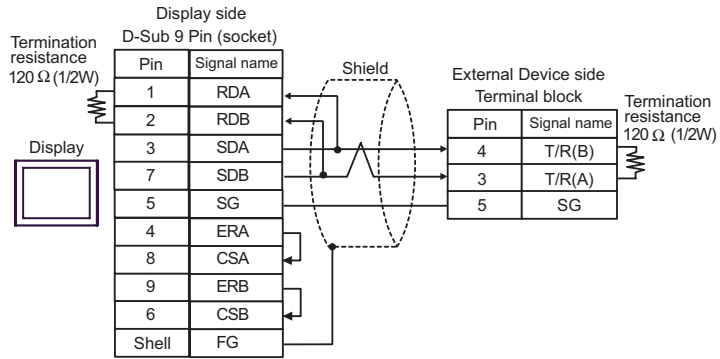

- 1:n Connection (When connecting with the internal communication line)

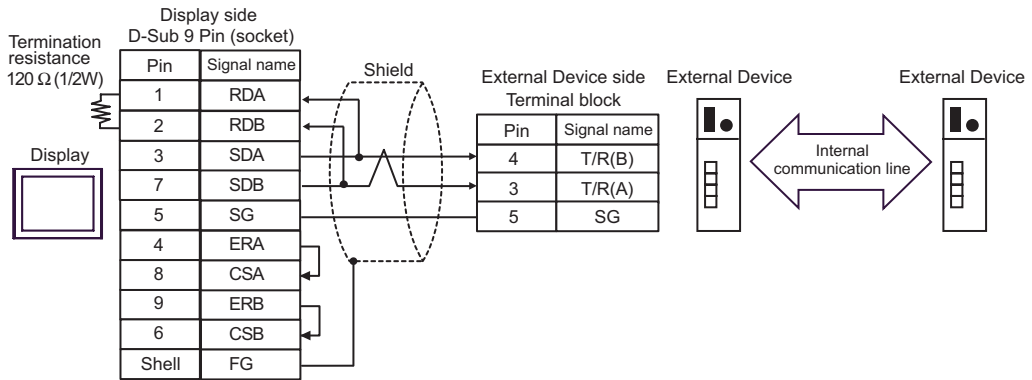

- 1:n Connection

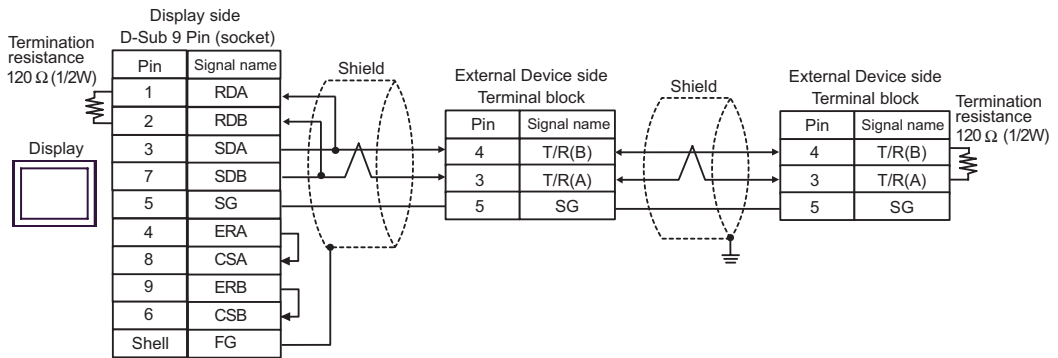

13C)

- 1:1 Connection

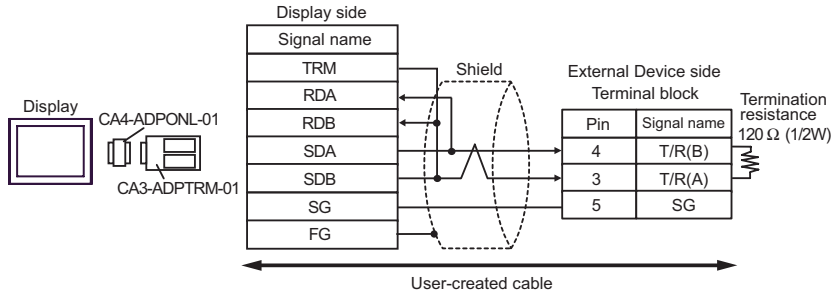

- 1:n Connection (When connecting with the internal communication line)

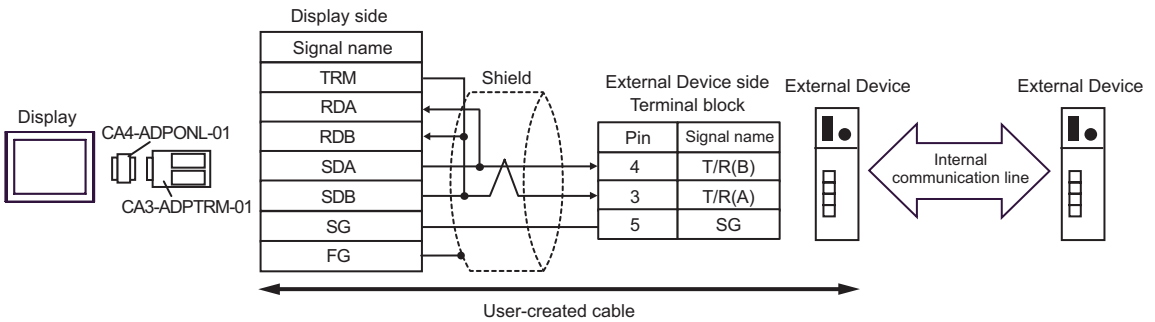

- 1:n Connection

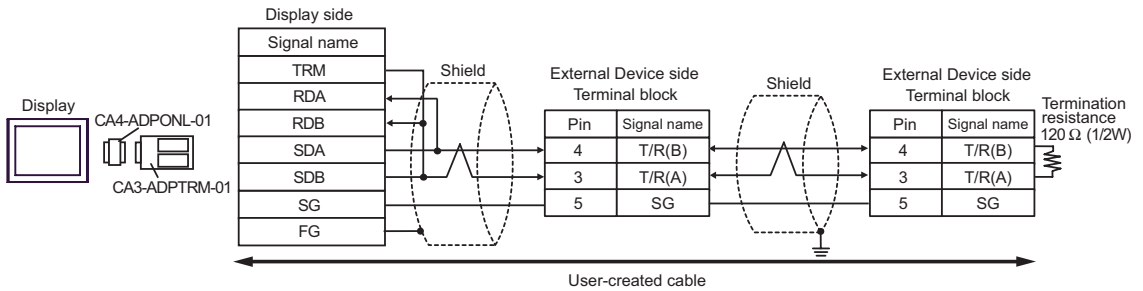

13D)

- 1:1 Connection

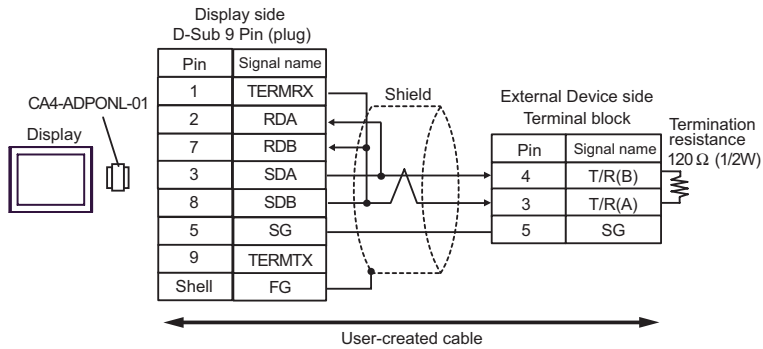

- 1:n Connection (When connecting with the internal communication line)

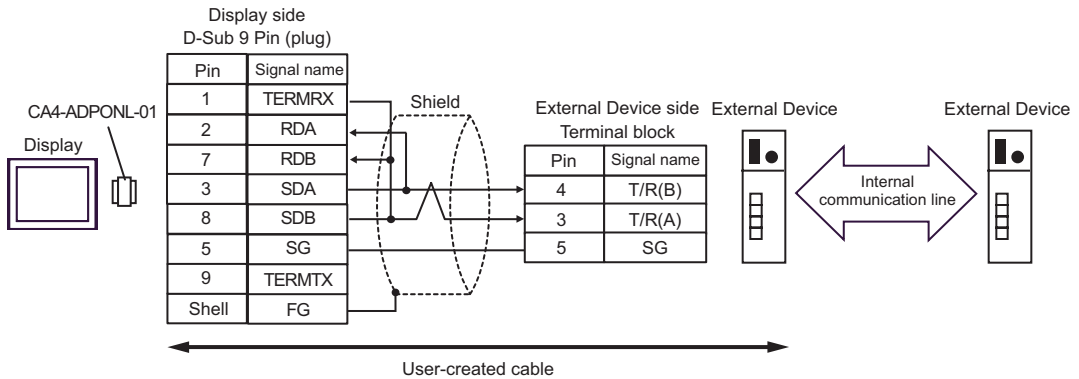

- 1:n Connection

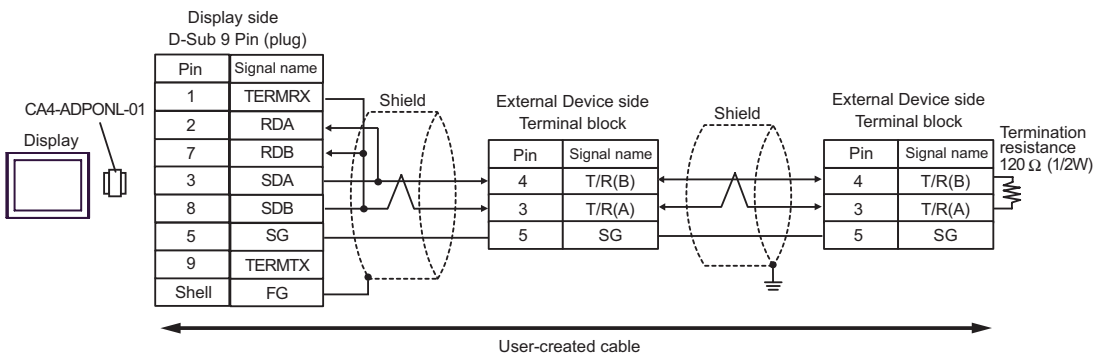

13E)

- 1:1 Connection

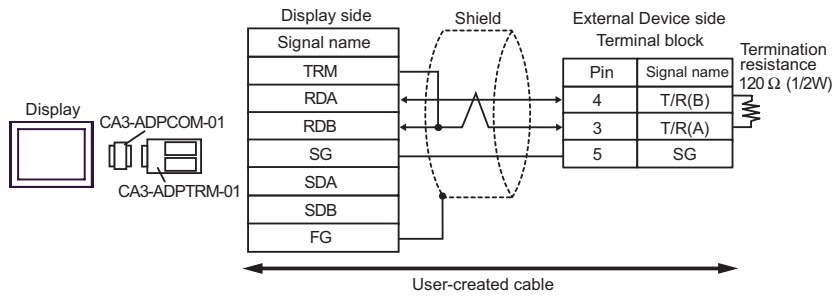

- 1:n Connection (When connecting with the internal communication line)

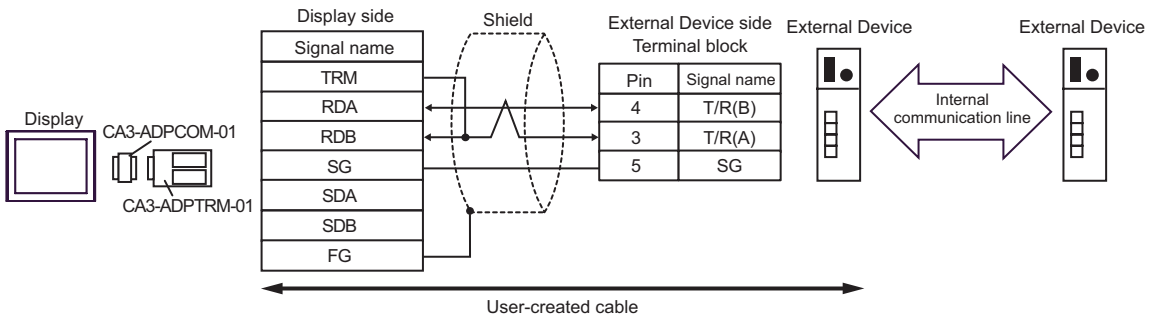

- 1:n Connection

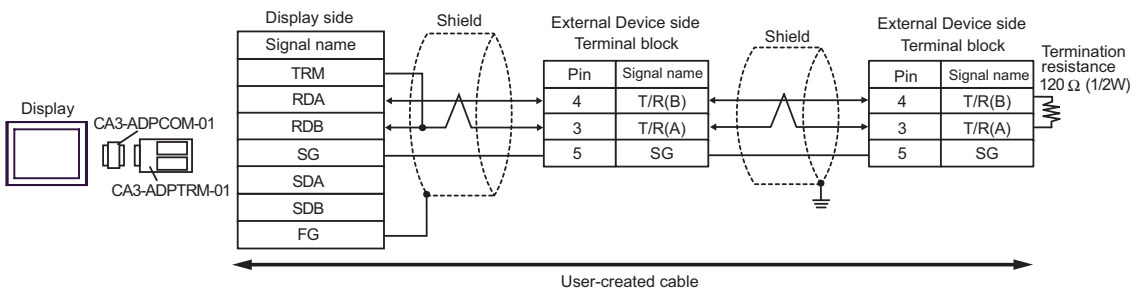

13F)

- 1:1 Connection

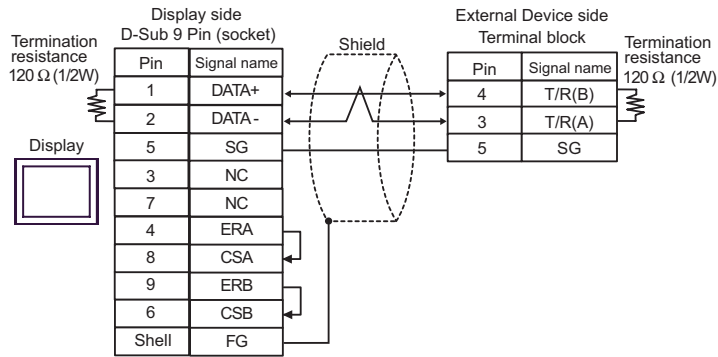

- 1:n Connection (When connecting with the internal communication line)

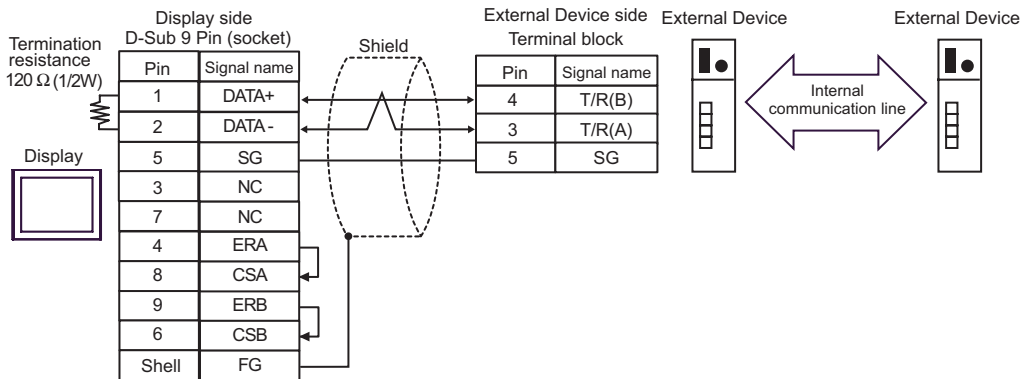

- 1:n Connection

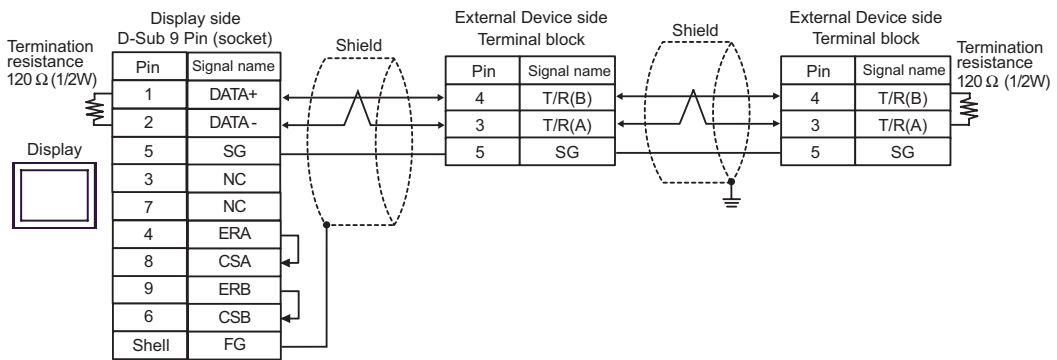

13G)

- 1:1 Connection

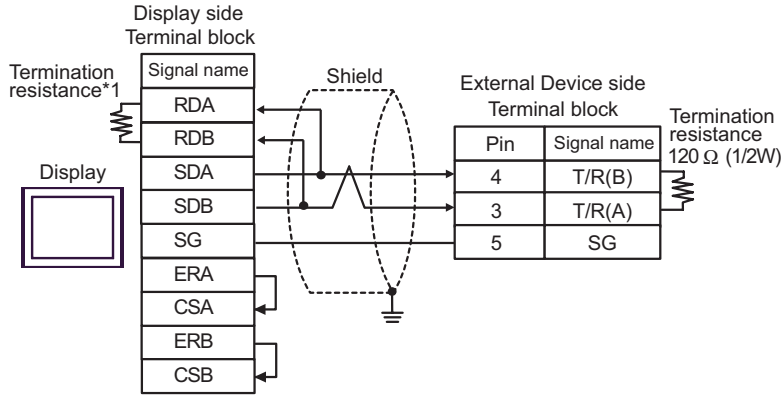

- 1:n Connection (When connecting with the internal communication line)

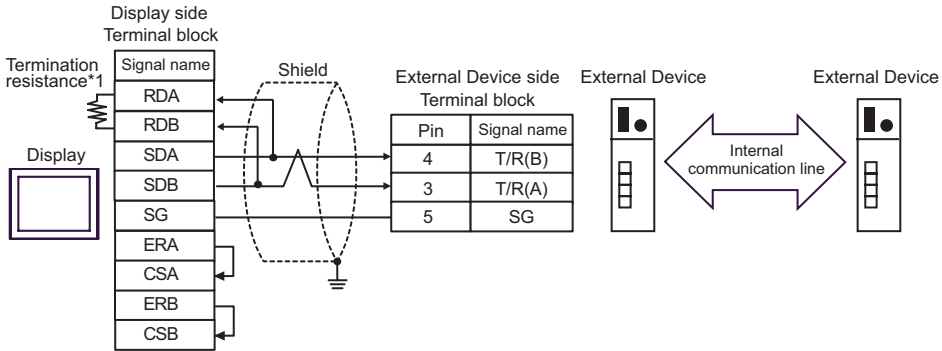

- 1:n Connection

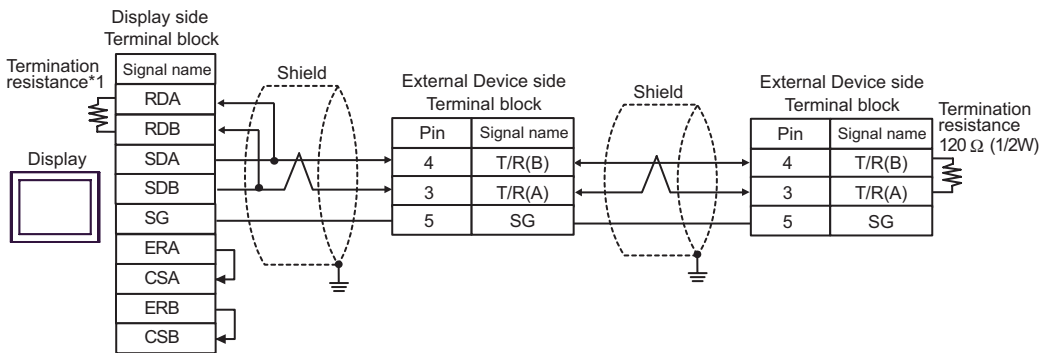

\*1 The resistance in the Display is used as the termination resistance. Set the value of the DIP Switch on the rear of the Display as shown in the table below.

DIP Switch No.	Set Value
1	OFF
2	OFF
3	ON
4	ON



13H)

- 1:1 Connection

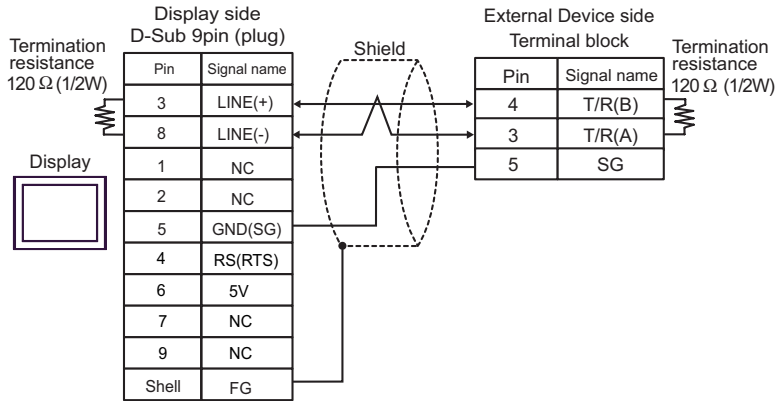

- 1:n Connection (When connecting with the internal communication line)

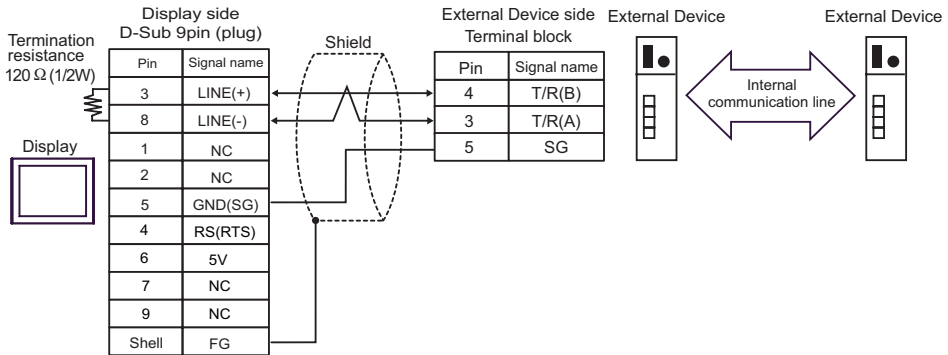

- 1:n Connection

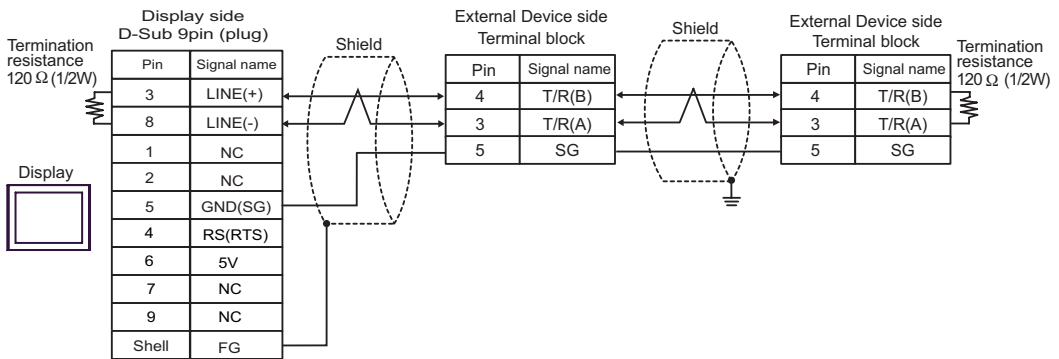

**IMPORTANT**

- The 5V output (Pin #6) on the Display is the power for the Siemens AG's PROFIBUS connector. Do not use it for other devices.

**NOTE**

- In COM on the GP-4107, the SG and FG terminals are isolated.

13I)

- 1:1 Connection

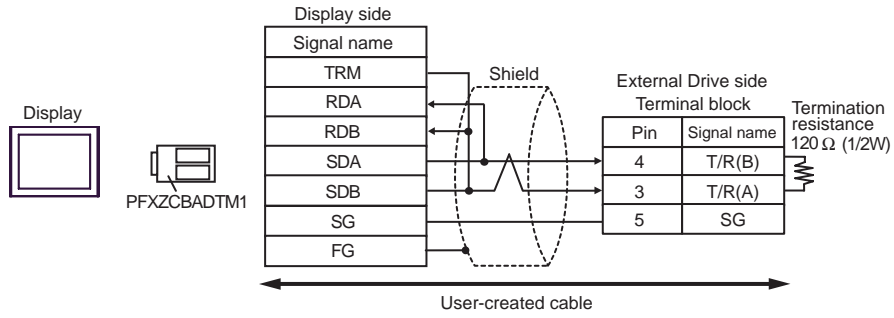

- 1:n Connection (When connecting with the internal communication line)

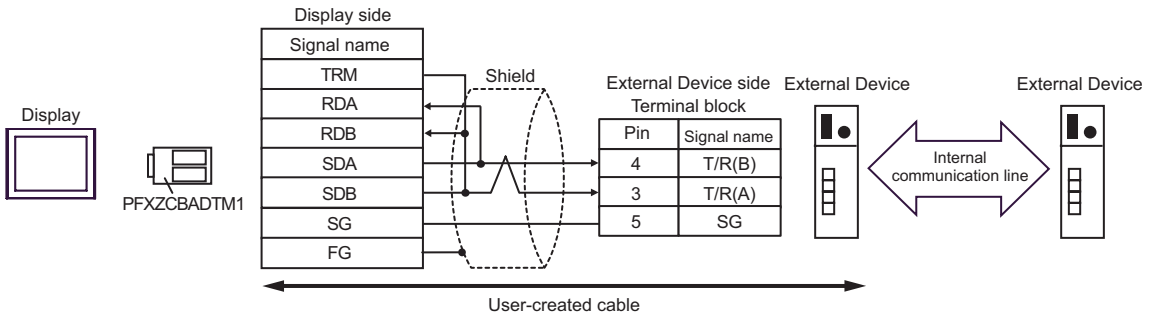

- 1:n Connection

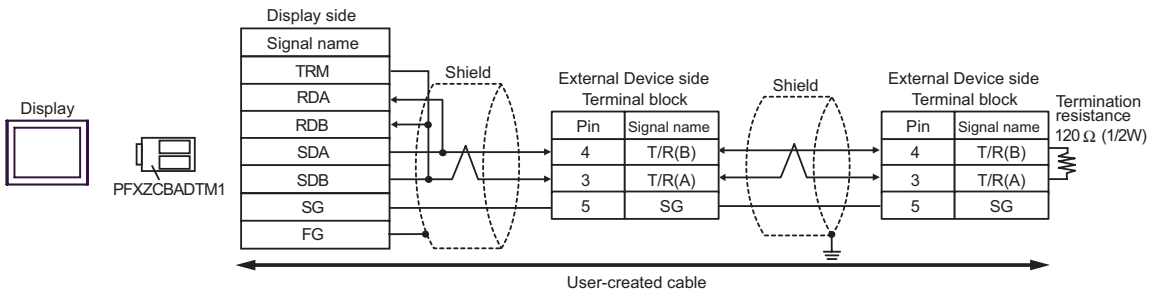

13J)

- 1:1 Connection

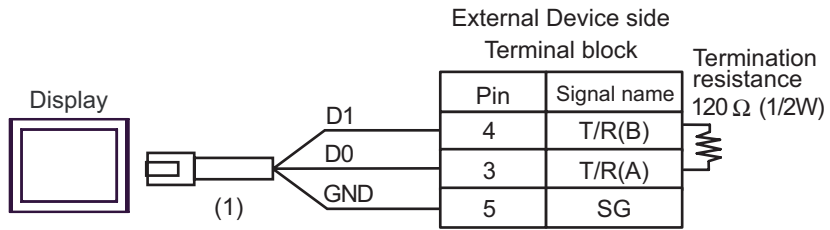

- 1:n Connection (When connecting with the internal communication line)

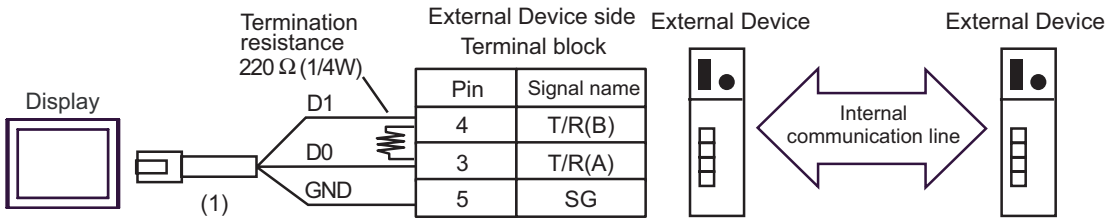

- 1:n Connection

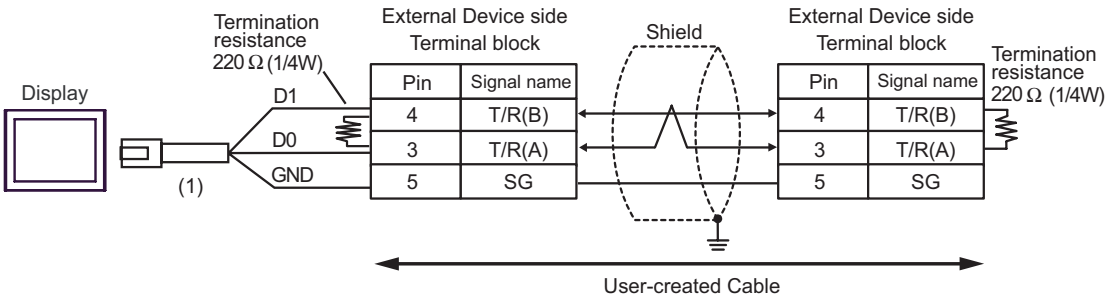

Number	Name	Notes
(1)	RJ45 RS-485 Cable (5m) by Pro-face PFXZLMCBJR81	

Cable Diagram 14

Display (Connection Port)	Cable		Remarks
GP3000* <sup>1</sup> (COM1) AGP-3302B (COM2) GP-4*01TM (COM1) ST* <sup>2</sup> (COM2) LT3000 (COM1) IPC* <sup>3</sup>	14A	COM port conversion adapter by Pro-face CA3-ADPCOM-01 + Terminal block conversion adapter by Pro-face CA3-ADPTRM-01 + User-created cable + Connection cable from RKC INSTRUMENT INC.* <sup>5</sup> W-BF-02	Cable length: 1200m or less
	14B	User-created cable + Connection cable from RKC INSTRUMENT INC.* <sup>5</sup> W-BF-02	
GP3000* <sup>4</sup> (COM2)	14C	Online adapter by Pro-face CA4-ADPONL-01 + Terminal block conversion adapter by Pro-face CA3-ADPTRM-01 + User-created cable + Connection cable from RKC INSTRUMENT INC.* <sup>5</sup> W-BF-02	
	14D	Online adapter by Pro-face CA4-ADPONL-01 + User-created cable + Connection cable from RKC INSTRUMENT INC.* <sup>5</sup> W-BF-02	
GP-4106 (COM1)	14E	User-created cable + Connection cable from RKC INSTRUMENT INC.* <sup>5</sup> W-BF-02	
GP4000* <sup>6</sup> (COM2) GP-4201T (COM1)	14F	RS-422 terminal block conversion adapter by Pro-face PFXZCBADTM1* <sup>7</sup> + User-created cable + Connection cable from RKC INSTRUMENT INC.* <sup>5</sup> W-BF-02	
	14B	User-created cable + Connection cable from RKC INSTRUMENT INC.* <sup>5</sup> W-BF-02	

\*1 All GP3000 models except AGP-3302B

\*2 All ST models except AST-3211A and AST-3302B

- \*3 Only the COM port which can communicate by RS-422/485 (4wire) can be used.  
 ☞ ■ IPC COM Port (page 9)
- \*4 All GP3000 models except GP-3200 and AGP-3302B
- \*5 To use multiple External Devices, utilize the W-BF-02 connection cable from RKC INSTRUMENT INC.
- \*6 All GP4000 models except GP-4100 series, GP-4\*01TM, GP-4201T and GP-4\*03T
- \*7 When using a Terminal Block Conversion Adapter (CA3-ADPTRM-01) instead of the RS-422 Terminal Block Conversion Adapter, refer to Cable Diagram 14A.

14A)

- 1:1 Connection

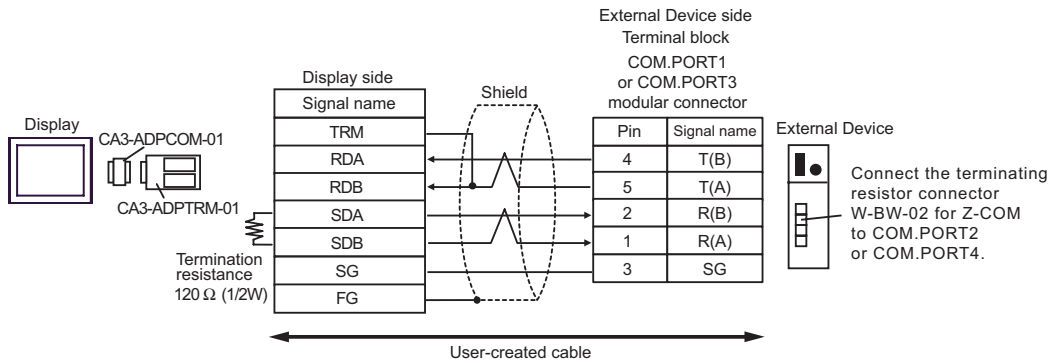

- 1:n Connection

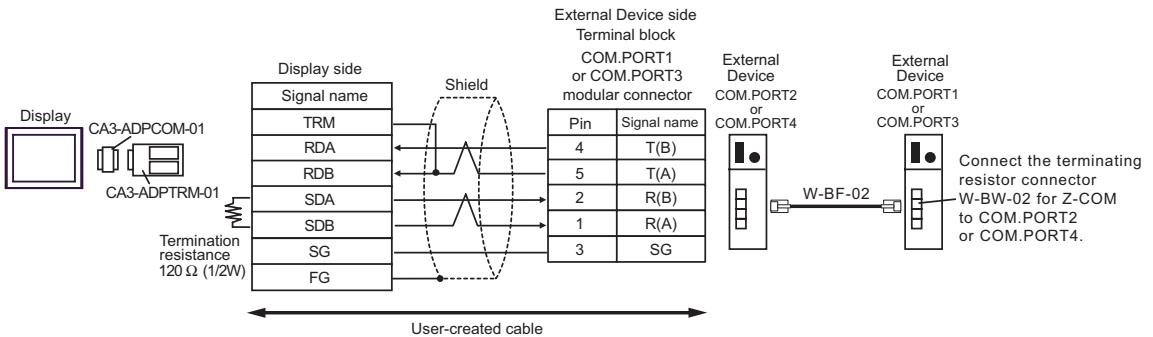

**NOTE**

- We recommend the TM4P-66P from HIROSE ELECTRIC CO., LTD. as the modular connector.
- To use the External Device's COM.PORT, pair COM.PORT1 with COM.PORT2, and COM.PORT3 with COM.PORT4.

14B)

- 1:1 Connection

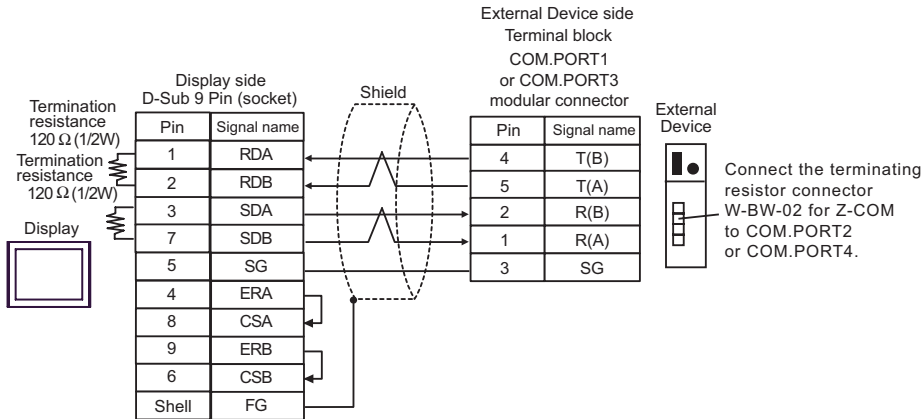

- 1:n Connection

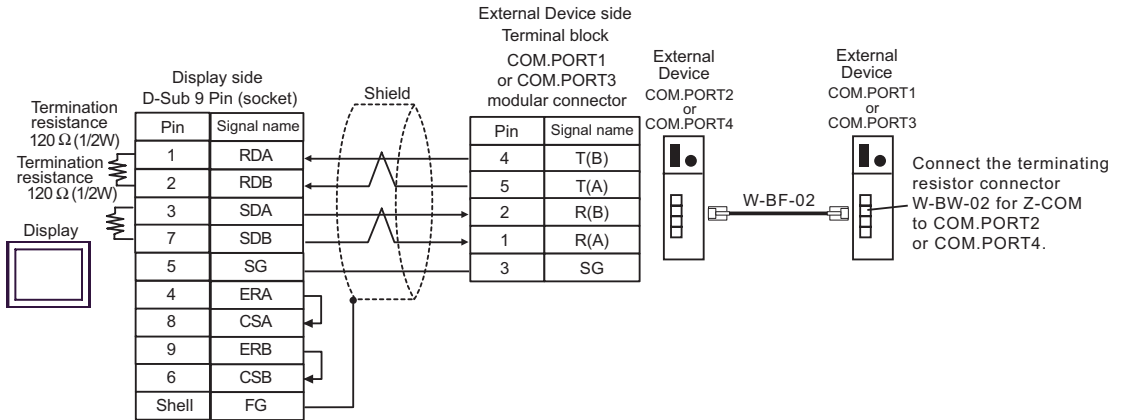

**NOTE**

- We recommend the TM4P-66P from HIROSE ELECTRIC CO., LTD. as the modular connector.
- To use the External Device's COM.PORT, pair COM.PORT1 with COM.PORT2, and COM.PORT3 with COM.PORT4.

14C)

- 1:1 Connection

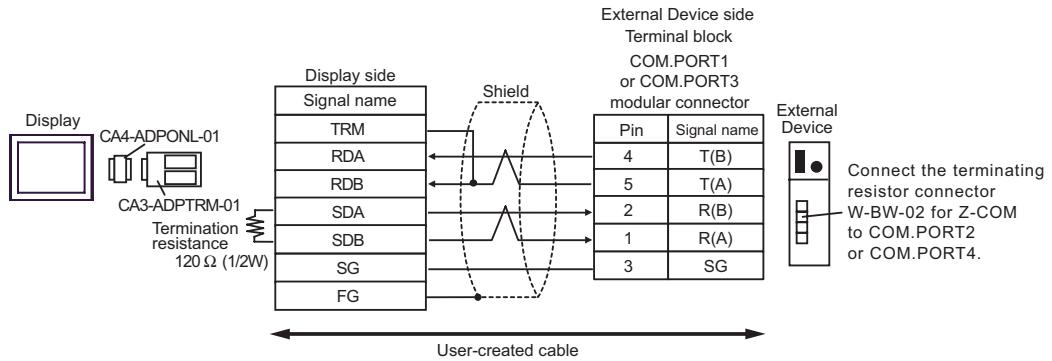

- 1:n Connection

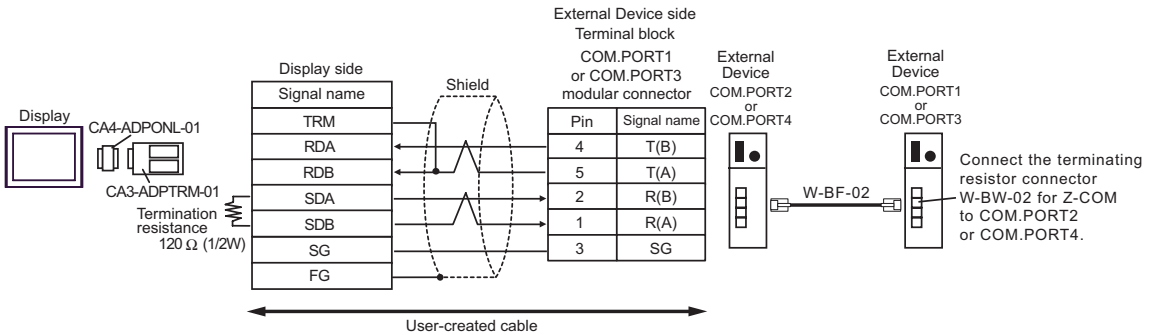

**NOTE**

- We recommend the TM4P-66P from HIROSE ELECTRIC CO., LTD. as the modular connector.
- To use the External Device's COM.PORT, pair COM.PORT1 with COM.PORT2, and COM.PORT3 with COM.PORT4.

14D)

• 1:1 Connection

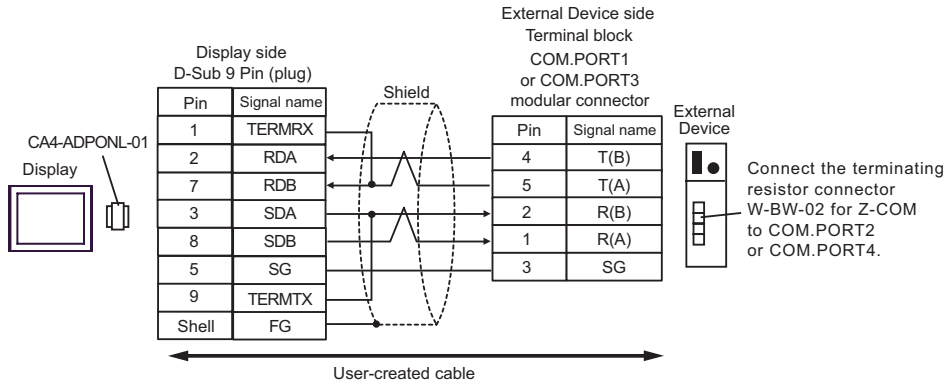

• 1:n Connection

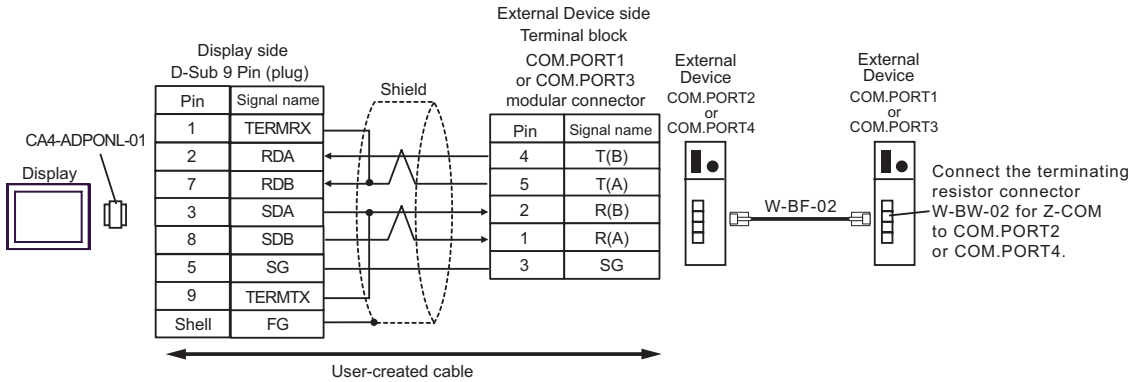

**NOTE**

- We recommend the TM4P-66P from HIROSE ELECTRIC CO., LTD. as the modular connector.
- To use the External Device's COM.PORT, pair COM.PORT1 with COM.PORT2, and COM.PORT3 with COM.PORT4.



14E)

- 1:1 Connection

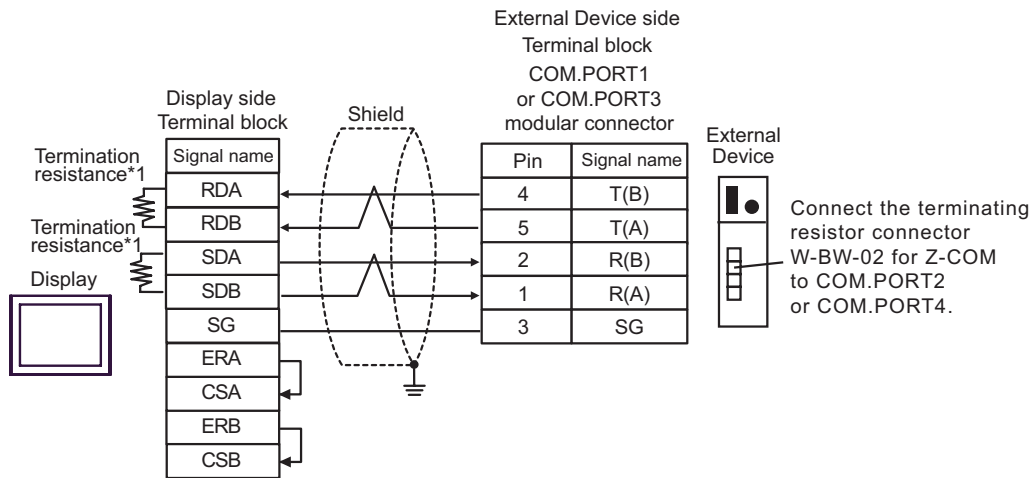

- 1:n Connection

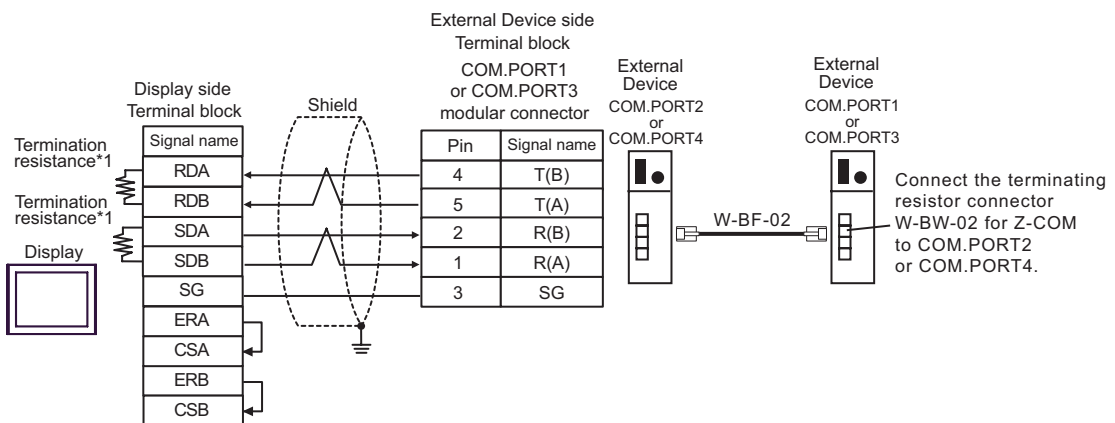

**NOTE**

- We recommend the TM4P-66P from HIROSE ELECTRIC CO., LTD. as the modular connector.
- To use the External Device's COM.PORT, pair COM.PORT1 with COM.PORT2, and COM.PORT3 with COM.PORT4.

\*1 The resistance in the Display is used as the termination resistance. Set the value of the DIP Switch on the rear of the Display as shown in the table below.

DIP Switch No.	Set Value
1	ON
2	ON
3	ON
4	ON

14F)

- 1:1 Connection

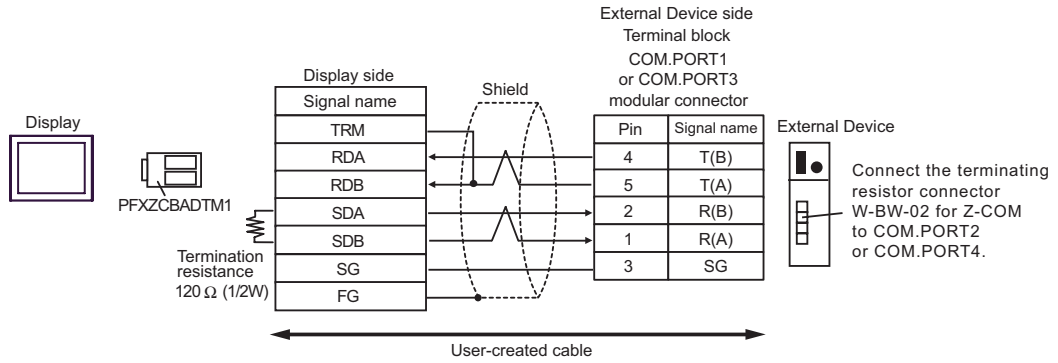

- 1:n Connection

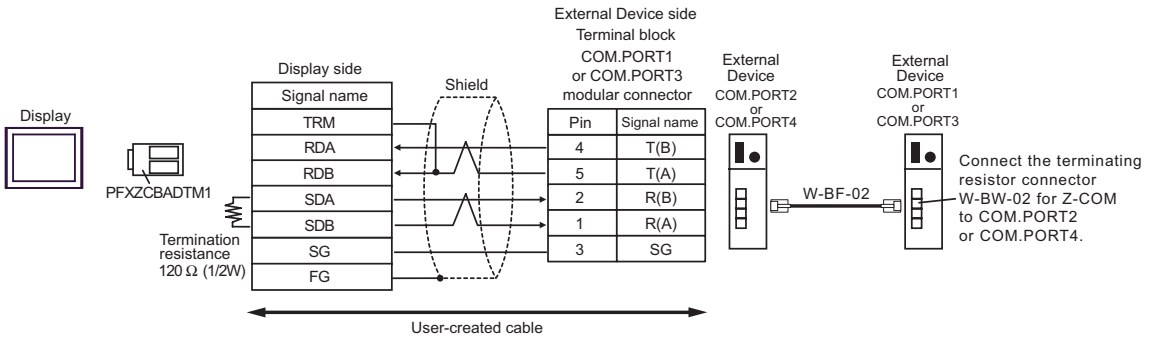

**NOTE**

- We recommend the TM4P-66P from HIROSE ELECTRIC CO., LTD. as the modular connector.
- To use the External Device's COM.PORT, pair COM.PORT1 with COM.PORT2, and COM.PORT3 with COM.PORT4.

## Cable Diagram 15

Display (Connection Port)	Cable		Remarks
GP3000* <sup>1</sup> (COM1) AGP-3302B (COM2) GP-4*0ITM (COM1) ST* <sup>2</sup> (COM2) LT3000 (COM1)	15A	COM port conversion adapter by Pro-face CA3-ADPCOM-01 + Terminal block conversion adapter by Pro-face CA3-ADPTRM-01 + User-created cable + Connection cable from RKC INSTRUMENT INC.* <sup>5</sup> W-BF-02	Cable length: 1200m or less
	15B	User-created cable + Connection cable from RKC INSTRUMENT INC.* <sup>5</sup> W-BF-02	
GP3000* <sup>3</sup> (COM2)	15C	Online adapter by Pro-face CA4-ADPONL-01 + Terminal block conversion adapter by Pro-face CA3-ADPTRM-01 + User-created cable + Connection cable from RKC INSTRUMENT INC.* <sup>5</sup> W-BF-02	
	15D	Online adapter by Pro-face CA4-ADPONL-01 + User-created cable + Connection cable from RKC INSTRUMENT INC.* <sup>5</sup> W-BF-02	
IPC* <sup>4</sup>	15E	COM port conversion adapter by Pro-face CA3-ADPCOM-01 + Terminal block conversion adapter by Pro-face CA3-ADPTRM-01 + User-created cable + Connection cable from RKC INSTRUMENT INC.* <sup>5</sup> W-BF-02	
	15F	User-created cable + Connection cable from RKC INSTRUMENT INC.* <sup>5</sup> W-BF-02	

Display (Connection Port)	Cable		Remarks
GP-4106 (COM1)	15G	User-created cable + Connection cable from RKC INSTRUMENT INC. *5 W-BF-02	Cable length: 1200m or less
GP-4107 (COM1) GP-4*03T*6 (COM2) GP-4203T (COM1)	15H	User-created cable + Connection cable from RKC INSTRUMENT INC. *5 W-BF-02	
GP4000*7 (COM2) GP-4201T (COM1)	15I	RS-422 terminal block conversion adapter by Pro-face PFXZCBADTM1*8 + User-created cable + Connection cable from RKC INSTRUMENT INC. *5 W-BF-02	
	15B	User-created cable + Connection cable from RKC INSTRUMENT INC. *5 W-BF-02	
LT-4*01TM (COM1)	15J	RJ45 RS-485 Cable (5m) by Pro-face PFXZLMCBRJR81 + Connection cable from RKC INSTRUMENT INC. *5 W-BF-02	

\*1 All GP3000 models except AGP-3302B

\*2 All ST models except AST-3211A and AST-3302B

\*3 All GP3000 models except GP-3200 and AGP-3302B

\*4 Only the COM port which can communicate by RS-422/485 (2wire) can be used.

 ■ IPC COM Port (page 9)

\*5 To use multiple External Devices, utilize the W-BF-02 connection cable from RKC INSTRUMENT INC.

\*6 Except GP-4203T

\*7 All GP4000 models except GP-4100 series, GP-4\*01TM, GP-4201T and GP-4\*03T

\*8 When using a Terminal Block Conversion Adapter (CA3-ADPTRM-01) instead of the RS-422 Terminal Block Conversion Adapter, refer to Cable Diagram 15A.

15A)

• 1:1 Connection

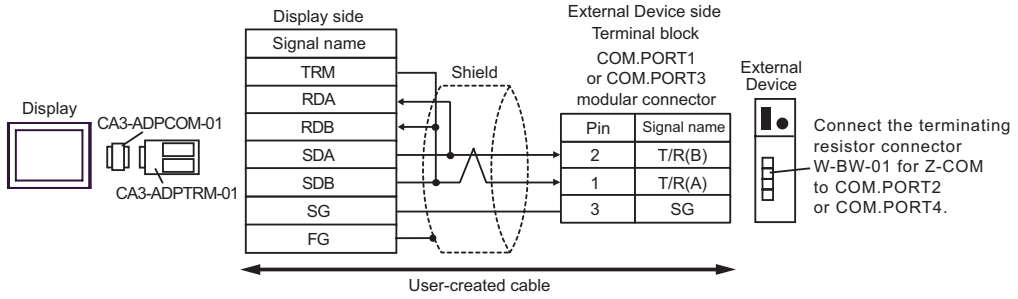

• 1:n Connection

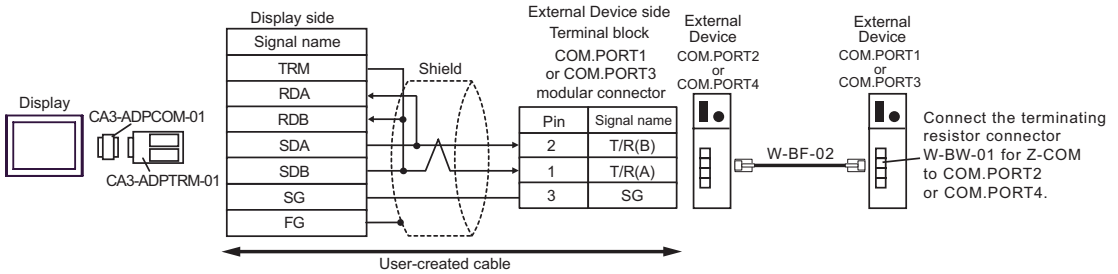

**NOTE**

- We recommend the TM4P-66P from HIROSE ELECTRIC CO., LTD. as the modular connector.
- To use the External Device's COM.PORT, pair COM.PORT1 with COM.PORT2, and COM.PORT3 with COM.PORT4.

15B)

• 1:1 Connection

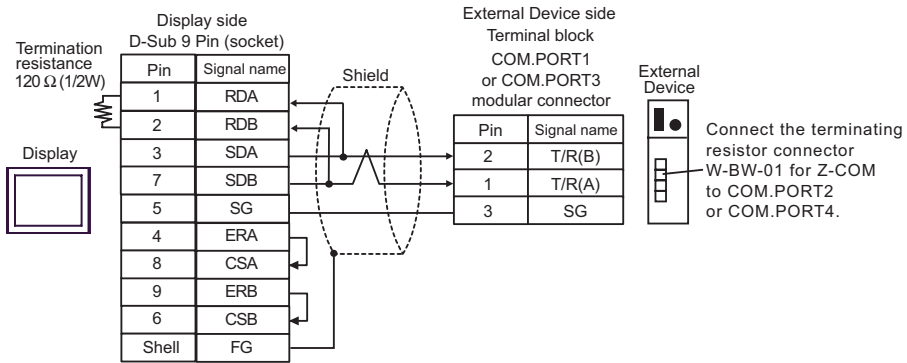

• 1:n Connection

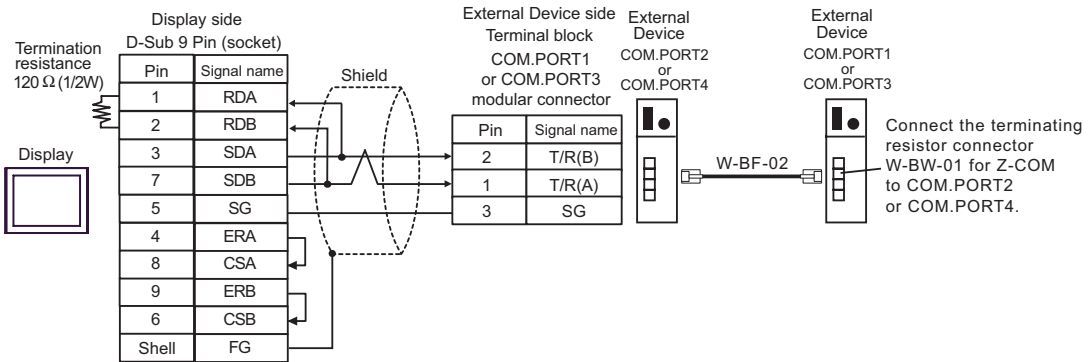

**NOTE**

- We recommend the TM4P-66P from HIROSE ELECTRIC CO., LTD. as the modular connector.
- To use the External Device's COM.PORT, pair COM.PORT1 with COM.PORT2, and COM.PORT3 with COM.PORT4.

15C)

• 1:1 Connection

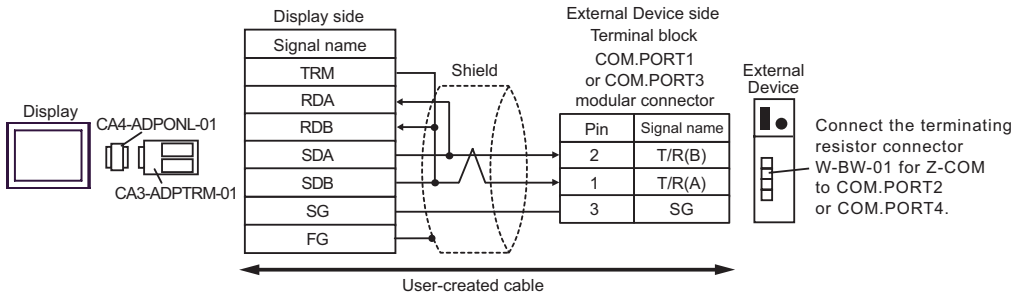

• 1:n Connection

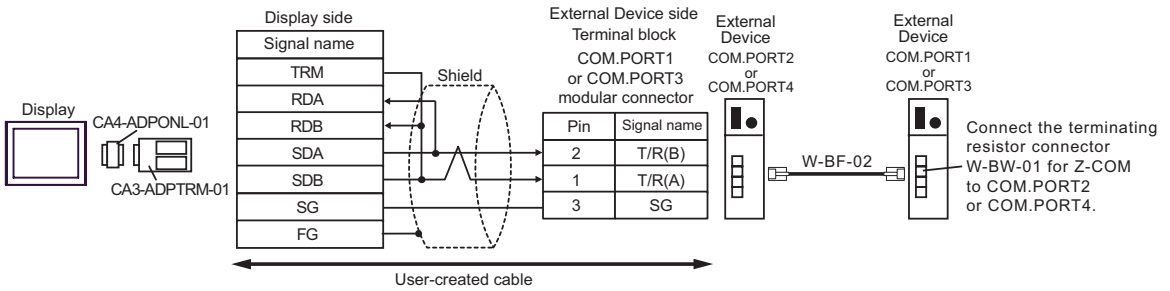

**NOTE**

- We recommend the TM4P-66P from HIROSE ELECTRIC CO., LTD. as the modular connector.
- To use the External Device's COM.PORT, pair COM.PORT1 with COM.PORT2, and COM.PORT3 with COM.PORT4.

15D)

- 1:1 Connection

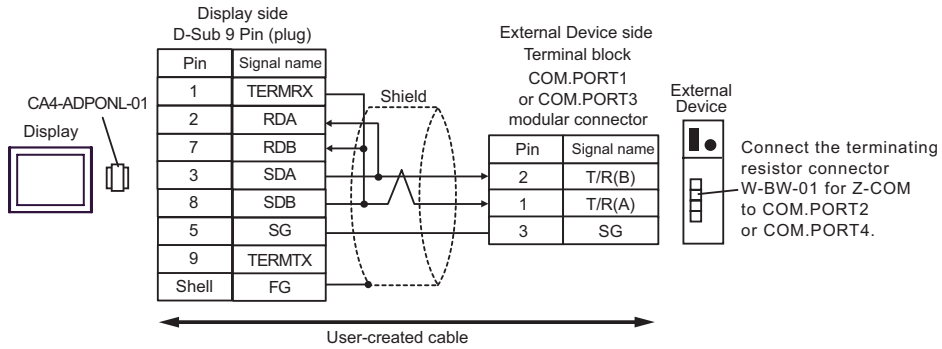

- 1:n Connection

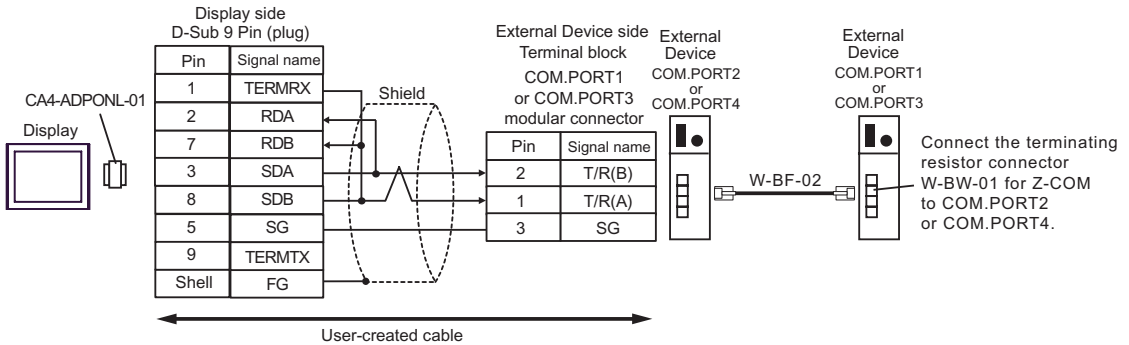

**NOTE**

- We recommend the TM4P-66P from HIROSE ELECTRIC CO., LTD. as the modular connector.
- To use the External Device's COM.PORT, pair COM.PORT1 with COM.PORT2, and COM.PORT3 with COM.PORT4.



15E)

• 1:1 Connection

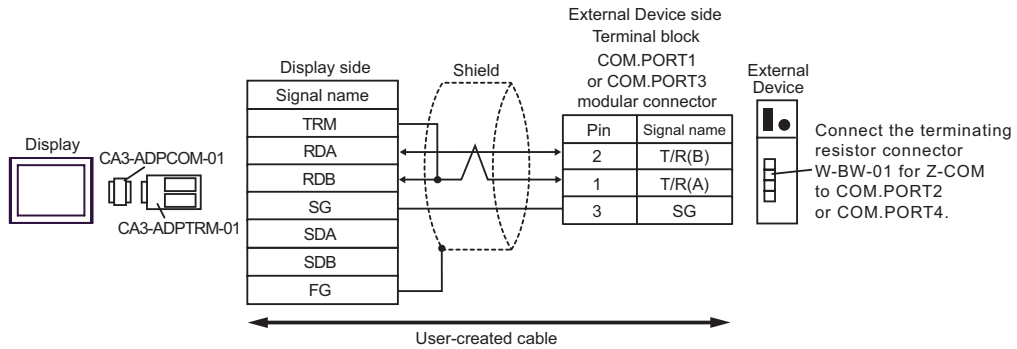

• 1:n Connection

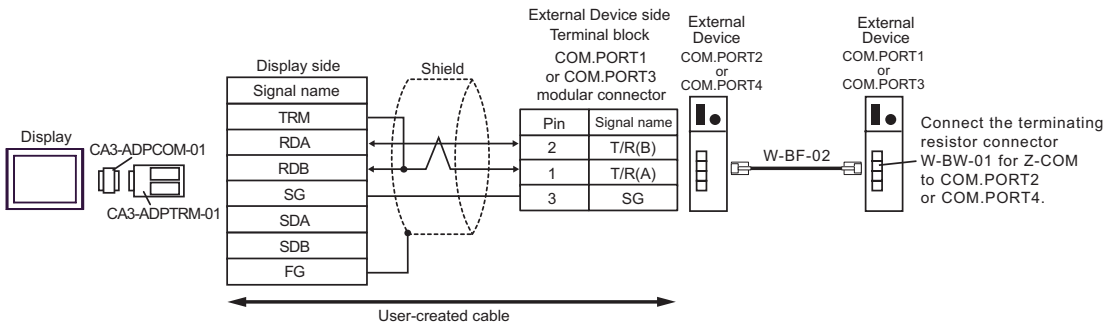

**NOTE**

- We recommend the TM4P-66P from HIROSE ELECTRIC CO., LTD. as the modular connector.
- To use the External Device's COM.PORT, pair COM.PORT1 with COM.PORT2, and COM.PORT3 with COM.PORT4.

15F)

- 1:1 Connection

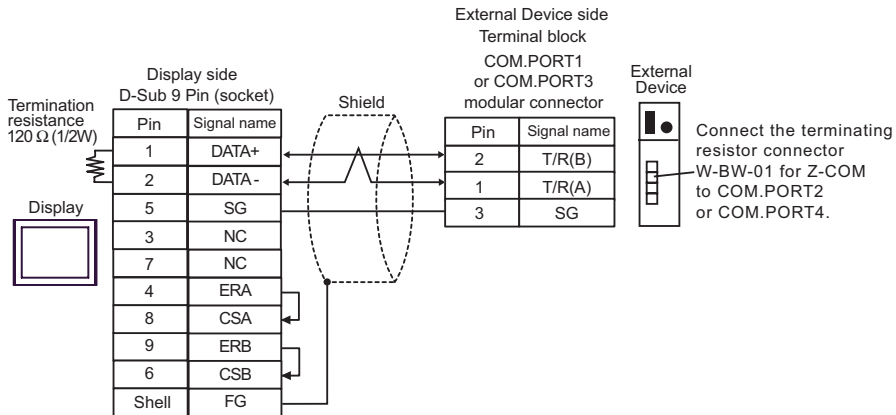

- 1:n Connection

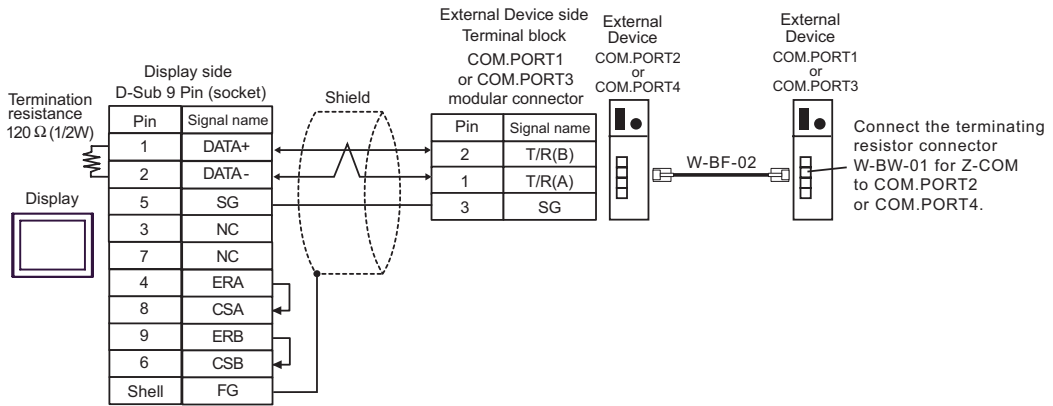

**NOTE**

- We recommend the TM4P-66P from HIROSE ELECTRIC CO., LTD. as the modular connector.
- To use the External Device's COM.PORT, pair COM.PORT1 with COM.PORT2, and COM.PORT3 with COM.PORT4.

15G)

• 1:1 Connection

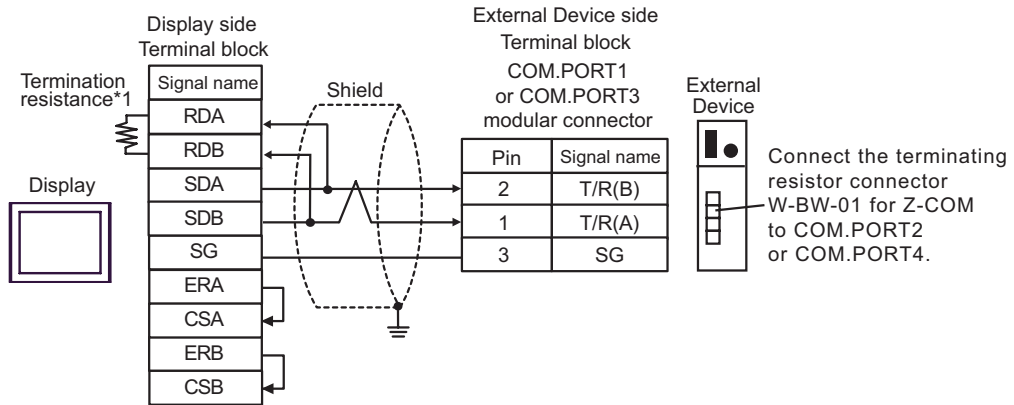

• 1:n Connection

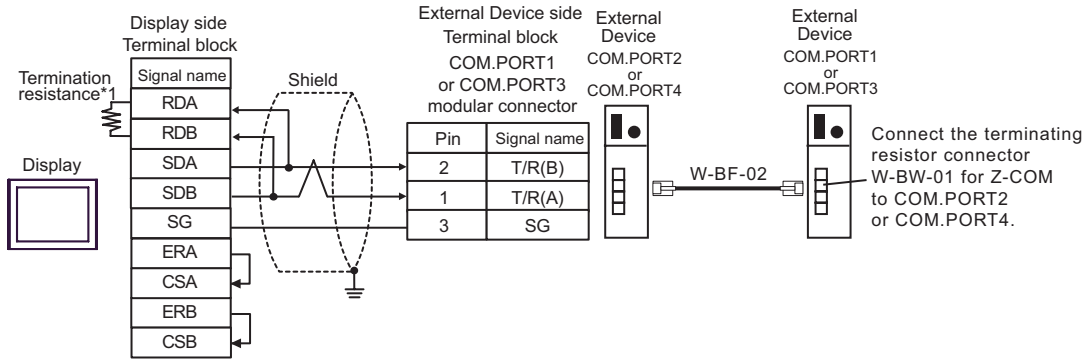

**NOTE**

- We recommend the TM4P-66P from HIROSE ELECTRIC CO., LTD. as the modular connector.
- To use the External Device's COM.PORT, pair COM.PORT1 with COM.PORT2, and COM.PORT3 with COM.PORT4.

\*1 The resistance in the Display is used as the termination resistance. Set the value of the DIP Switch on the rear of the Display as shown in the table below.

DIP Switch No.	Set Value
1	OFF
2	OFF
3	ON
4	ON

15H)

- 1:1 Connection

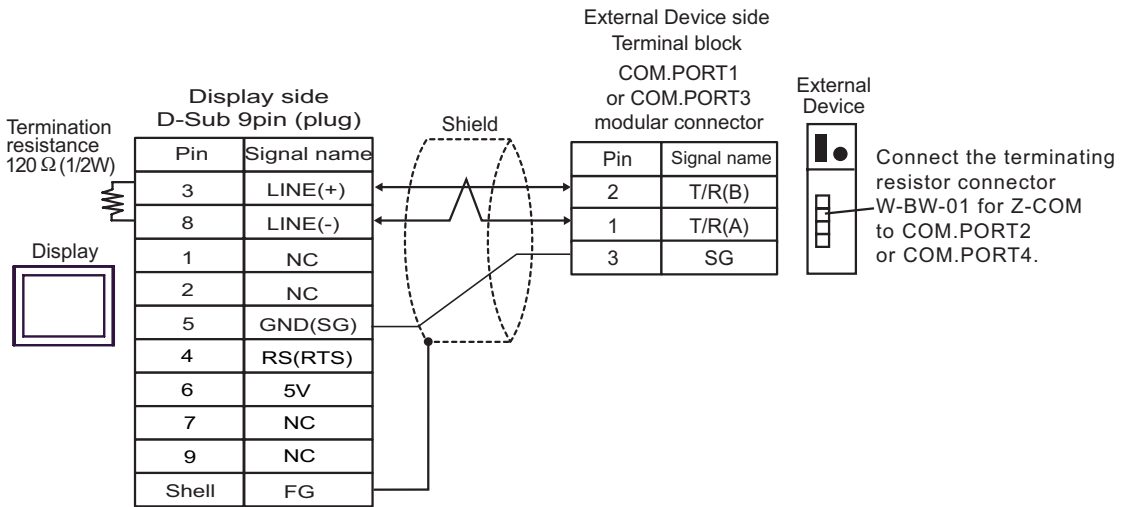

- 1:n Connection

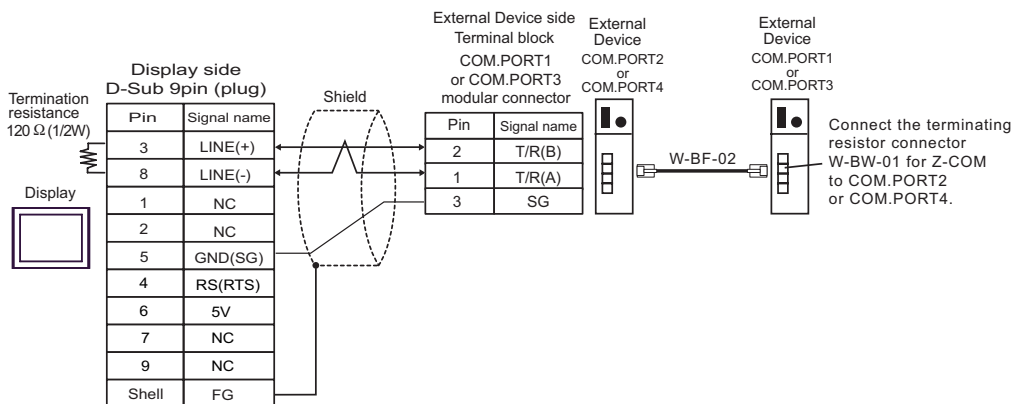

**IMPORTANT**

- The 5V output (Pin #6) on the Display is the power for the Siemens AG's PROFIBUS connector. Do not use it for other devices.

**NOTE**

- We recommend the TM4P-66P from HIROSE ELECTRIC CO., LTD. as the modular connector.
- To use the External Device's COM.PORT, pair COM.PORT1 with COM.PORT2, and COM.PORT3 with COM.PORT4.
- In COM on the GP-4107, the SG and FG terminals are isolated.

15I)

- 1:1 Connection

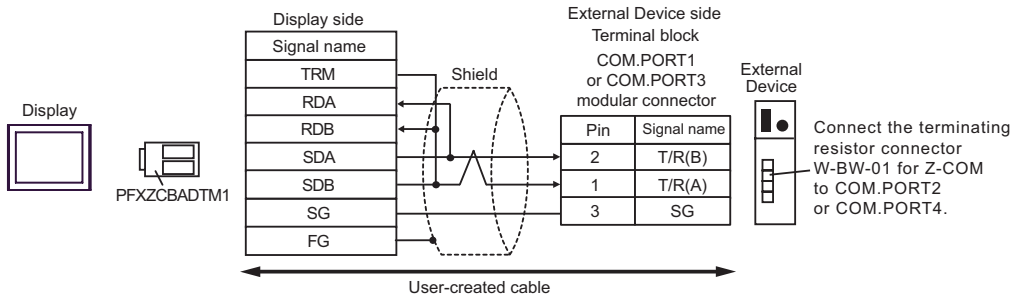

- 1:n Connection

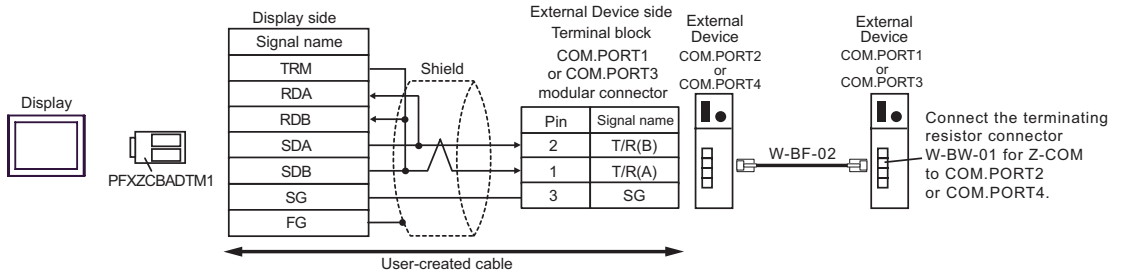

**NOTE**

- We recommend the TM4P-66P from HIROSE ELECTRIC CO., LTD. as the modular connector.
- To use the External Device's COM.PORT, pair COM.PORT1 with COM.PORT2, and COM.PORT3 with COM.PORT4.

15J)

- 1:1 Connection

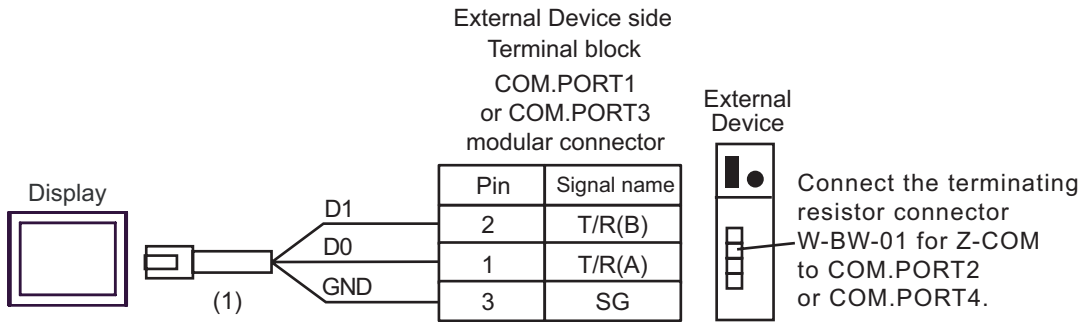

- 1:n Connection

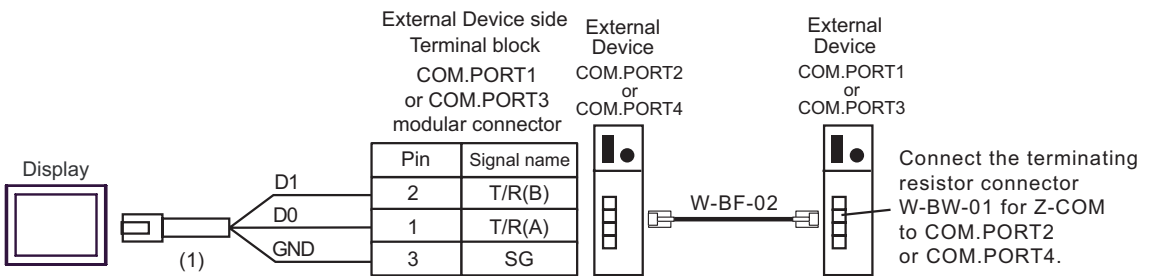

**NOTE**

- We recommend the TM4P-66P from HIROSE ELECTRIC CO., LTD. as the modular connector.
- To use the External Device's COM.PORT, pair COM.PORT1 with COM.PORT2, and COM.PORT3 with COM.PORT4.

Number	Name	Notes
(1)	RJ45 RS-485 Cable (5m) by Pro-face PFXZLMCBRJR81	

## 6 Supported Device

Range of supported device address is shown in the table below. Please note that the actually supported range of the devices varies depending on the External Device to be used. Please check the actual range in the manual of your connecting equipment.

Input address of external device in the dialog below.

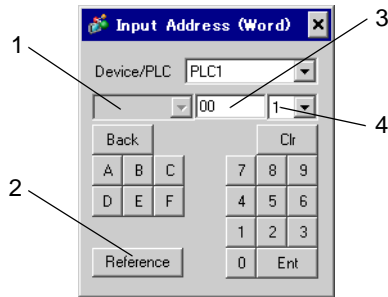

- |                         |   |
|-------------------------|---|
| 1. Channel number       | Select the channel number of external device.<br>It can be selected when SR Mini HG(H-PCP-A/B), SR Mini HG(H-PCP-J), SRZ(Z-TIO), SRZ(Z-DIO), SRZ(Z-CT) and SRZ(Z-COM) are used. |
| 2. Reference            | The list of available identifiers is displayed.<br>When clicking the identifier to be used and pressing "Select," the address is inputted.                                      |
| 3. Address              | Address is set.<br>Combination of identifier and address differs per external device. Please refer to the list of identifiers.  |
| 4. Decimal digit number | Decimal digit number of data is set.  |

■ When reading out:

Data read out from the temperature controller are dealt as integral number.

e.g. When the value of temperature controller is 100.0;

Value of temperature controller: 100.0

Value indicated by display: 1000

To display decimal points in value indication, set "decimal digit number" of "display data form." In the case of the example above, the decimal digit number is the first decimal place, so set "1."

e.g. When the value of temperature controller is 100.0;

Value of temperature controller: 100.0

Value indicated by Display: 100.0

The decimal point position is internally processed depending on the specified address.

Specified same as the address on the device list: No decimal point

Specified by adding 0x1000 to the address on the device list

: One digit after decimal point.

Specified by adding 0x2000 to the address on the device list

: Two digit after decimal point.

Specified by adding 0x3000 to the address on the device list

: Three digit after decimal point.

GP data are as follows depending on the address specifying method.

Data of temperature controller	Data of display			
	Specified same as the address	Specified by adding 0x1000 to the address	Specified by adding 0x2000 to the address	Specified by adding 0x3000 to the address
123	123	1230	12300	23000
123.4	123	1234	12340	23400
12.34	12	123	1234	12340
1.234	1	12	123	1234

\* When address specifying method does not match decimal point position of data of temperature controller, truncate the decimal digit number of the specified address or add a zero.

Data are indicated in decadal system and are 6 digits or more, upper level digits are truncated.

■ When writing:

When writing in the temperature controller, value is set in integral number. Decimal point position is internally processed depending on the specified address.

Specified same as the address on the device list: No decimal point

Specified by adding 0x1000 to the address on the device list

: One digit after decimal point.

Specified by adding 0x2000 to the address on the device list

: Two digit after decimal point.

Specified by adding 0x3000 to the address on the device list

: Three digit after decimal point.

Example 1) When writing 100.0 in the first alarm setting (A1) of CB series;

Address value set by indicator: 0x1007

Written value set by indicator: 1000

Example 2) When writing 100 in the first alarm setting (A1) of CB series;

Address value set by indicator: 0x0007

Written value set by indicator: 100

Data written in the temperature controller are as follows depending on the address specifying method.

Data of temperature controller	Data written in the temperature controller			
	Specified same as the address	Specified by adding 0x1000 to the address	Specified by adding 0x2000 to the address	Specified by adding 0x3000 to the address
1	1	0.1	0.01	0.001
123	123	12.3	1.23	0.123
1234	1234	123.4	12.34	1.234

\* When address specifying method does not match decimal point position of data of temperature controller, truncate the decimal digit number of the specified address or add a zero.



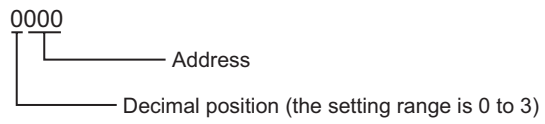

For details of the setting value range or decimal point position of each identifier, please refer to the communication manual of the temperature controller made by RKC INSTRUMENT INC.

- 
- NOTE** • The decimal position is saved together with the device string.



## 6.1 CB Series

 This address can be specified as system data area.

Device	Bit Address	Word Address	32 bits	Notes
Communication identifier	0000.00-0038.F	0000-0038		*1 *2

- \*1 There are cases for which writing is not available depending on the device address. Check the identifying attributes of the external device's manual before use.
- \*2 When bit is written, the indicator reads the corresponding word address of external device, assign a bit to the read word address, and return to the external device. There are cases when correct data cannot be written if the word address is written using a ladder program, while the indicator reads data of the external device and sends it back.

## &lt;Communication identifier list&gt;

Address	Identifier	Description
00	M1	Measured value (PV)
01	M2	Current transformer input 1
02	M3	Current transformer input 2
03	AA	Alarm 1 status
04	AB	Alarm 2 status
05	B1	Burnout
06	S1	Set value (SV)
07	A1	Alarm 1 setting
08	A2	Alarm 2 setting
09	A3	Heater break alarm 1 setting
0A	A4	Heater break alarm 2 setting
0B	A5	Control loop break alarm (LBA) setting
0C	A6	LBA deadband
0D	G1	Autotuning (AT)
0E	G2	Self-tuning (ST)
0F	P1	Heat-side proportional band
10	I1	Integral time
11	D1	Derivative time
12	W1	Anti-reset windup
13	T0	Heat-side proportioning cycle
14	P2	Cool-side proportional band
15	V1	Overlap/deadband
16	T1	Cool-side proportioning cycle
17	PB	PV bias
18	LK	Set data lock function
19	SR	RUN/STOP transfer
1A	ER	Error code
1B	IO	Initialization mode selection
1C	IP	Setting necessary code [Cod]
1D	XI	Input type selection [SL1]
1E	XQ	Engineering unit and cooling type selection [SL2]
1F	LV	Heater break alarm (HBA), control loop break alarm (LBA), special specification, or control loop break alarm (LBA) output selection [SL3]
20	XA	First alarm (ALM1) type or First alarm (ALM1) with hold action selection [SL4]
21	XB	Second alarm (ALM2) type or Second alarm (ALM2) with hold action selection [SL5]

Address	Identifier	Description
22	CA	Control action type selection [SL6]
23	Z1	Energized/de-energized alarm selection, special specification selection 1 [SL7]
24	Z2	Special specification selection 2 [SL8]
25	Z3	Special specification selection 3 [SL9]
26	DH	Option selection [SL10]
27	XC	SV alarm type selection [SL11]
28	XV	Setting limiter (high limit) [SLH]
29	XW	Setting limiter (low limit) [SLL]
2A	XU	Setting the position of decimal point [PGdP]
2B	MH	Differential gap setting of ON/OFF action [oH]
2C	HA	Differential gap setting of first alarm (ALM1) [AH1]
2D	HB	Differential gap setting of second alarm (ALM2) [AH2]
2E	XR	CT ratio setting [CTr]
2F	F1	Digital filter setting [dF]
30	GH	Time factor assumed to be safe [STTM]
31	PU	Factor to calculate proportional band [STPK]
32	IU	Factor to calculate integral time [STIK]
33	IL	Integral time limiter [ILIM]
34	HP	Holding peak ambient temperature [TCJ]
35	UT	Operating time display unit (Upper digits) [WTH]
36	UU	Operating time display unit (Lower digits) [WTL]
37	EB	EEPROM storage mode
38	EM	EEPROM storage state

**IMPORTANT**

- Setting "Use system data area" to GP-Pro EX system area result in improper operation. Do not set "Use system data area."

**NOTE**

- System area setting that can be used for the temperature controller is reading area size only. Please refer to the GP-Pro EX Reference Manual for system data area.  
Cf. GP-Pro EX Reference Manual "LS Area (Direct Access Method Area)"
- Please refer to the precautions on manual notation for icons in the table.  
☞ "Manual Symbols and Terminology"
- Even if non-existing address is used, there are cases when read error is not indicated. In this case, zero (0) is kept for read out data. On the other hand, writing error is indicated.

## 6.2 FB Series

 This address can be specified as system data area.

Device	Bit Address	Word Address	32 bits	Notes
Communication identifier	0000.00-00CF.1F	0000-00CF		*1 *2 *3

- \*1 There are cases for which writing is not available depending on the device address. Check the identifying attributes of the external device's manual before use.
- \*2 When bit is written, the indicator reads the corresponding word address of external device, assign a bit to the read word address, and return to the external device. There are cases when correct data cannot be written if the word address is written using a ladder program, while the indicator reads data of the external device and sends it back.
- \*3 32-bit device

## &lt;Communication identifier list&gt;

Address	Identifier	Description
0	M1	Measured value (PV) monitor
1	M3	Current transformer 1 (CT1) input value monitor
2	M4	Current transformer 2 (CT2) input value monitor
3	MS	Set value (SV) monitor
4	S2	Remote setting (RS) input value monitor
5	B1	Burnout state monitor
6	B2	Burnout state monitor of feedback resistance input
7	AA	Event 1 state monitor
8	AB	Event 2 state monitor
9	AC	Event 3 state monitor
0A	AD	Event 4 state monitor
0B	AE	Heater break alarm 1 (HBA1) state monitor
0C	AF	Heater break alarm 2 (HBA2) state monitor
0D	O1	Manipulated output value (MV1) monitor [heat-side]
0E	O2	Manipulated output value (MV2) monitor [cool-side]
0F	ER	Error code
10	L1	Digital input (DI) state monitor
11	Q1	Output state monitor
12	L0	Operation mode state monitor
13	TR	Memory area soak time monitor
14	UT	Integrated operating time monitor
15	Hp	Holding peak value ambient temperature monitor
16	HM	Power feed forward input value monitor
17	EM	Backup memory state monitor
18	VR	ROM version monitor (1-4 character)
19	G1	PID/AT transfer
1A	J1	Auto/Manual transfer
1B	C1	Remote/Local transfer
1C	SR	RUN/STOP transfer
1D	ZA	Memory area transfer
1E	IL	Interlock release
1F	A1	Event 1 set value (EV1)
20	A2	Event 2 set value (EV2)
21	A3	Event 3 set value (EV3)

Address	Identifier	Description
22	A4	Event 4 set value (EV4)
23	A5	Control loop break alarm (LBA) time
24	N1	LBA deadband
25	S1	Set value (SV)
26	P1	Proportional band [heat-side]
27	I1	Integral time [heat-side]
28	D1	Derivative time [heat-side]
29	CA	Control response parameter
2A	P2	Proportional band [cool-side]
2B	I2	Integral time [cool-side]
2C	D2	Derivative time [cool-side]
2D	V1	Overlap/Deadband
2E	MR	Manual reset
2F	HH	Setting change rate limiter (up)
30	HL	Setting change rate limiter (down)
31	TM	Area soak time
32	LP	Link area number
33	A7	Heater break alarm 1 (HBA1) set value
34	NE	Heater break determination point 1
35	NF	Heater melting determination point 1
36	A8	Heater break alarm 2 (HBA2) set value
37	NH	Heater break determination point 2
38	NI	Heater melting determination point 2
39	PB	PV bias
3A	F1	PV digital filter
3B	PR	PV ratio
3C	DP	PV low input cut-off
3D	RB	RS bias
3E	F2	RS digital filter
3F	PR	RS ratio
40	T0	Proportional cycle time [heat-side]
41	T1	Proportional cycle time [cool-side]
42	ON	Manual manipulated output value
43	LK	Set lock level
44	DX	STOP display
45	DA	Bar graph display
46	DE	Bar graph display resolution
47	DK	Direct key 1
48	DL	Direct key 2
49	DM	Direct key 3
4A	DN	Direct key type
4B	XI	Input type
4C	PU	Display unit
4D	XU	Decimal point position
4E	XV	Input scale high
4F	XW	Input scale low
50	AV	Input error determination point (high)
51	AW	Input error determination point (low)
52	BS	TC input burnout direction
53	XH	Square root extraction
54	JT	Power supply frequency
55	TZ	Sampling cycle

Address	Identifier	Description
56	XR	Remote setting input type
57	H2	Digital input (DI) assignment
58	E0	Output assignment
59	TH	Timer 1
5A	TI	Timer 2
5B	TJ	Timer 3
5C	TK	Timer 4
5D	NA	Energized/De-energized
5E	LY	Alarm (ALM) lamp lighting condition 1
5F	LZ	Alarm (ALM) lamp lighting condition 2
60	SS	Output status at STOP mode
61	LA	Transmission output type
62	HV	Transmission output scale high
63	HW	Transmission output scale low
64	XA	Event 1 type
65	WA	Event 1 hold action
66	LF	Event 1 interlock
67	HA	Event 1 differential gap
68	TD	Event 1 delay timer
69	OA	Event 1 action at input error
6A	XB	Event 2 type
6B	WB	Event 2 hold action
6C	LG	Event 2 interlock
6D	HB	Event 2 differential gap
6E	TG	Event 2 delay timer
6F	OB	Event 2 action at input error
70	XC	Event 3 type
71	WC	Event 3 hold action
72	LH	Event 3 interlock
73	HC	Event 3 differential gap
74	TE	Event 3 delay timer
75	OC	Event 3 action at input error
76	XD	Event 4 type
77	WD	Event 4 hold action
78	LI	Event 4 interlock
79	HD	Event 4 differential gap
7A	TF	Event 4 delay timer
7B	OD	Event 4 action at input error
7C	XS	CT1 ratio
7D	ZF	CT1 assignment
7E	ND	Heater break alarm 1 (HBA1) type
7F	DH	Number of heater break alarm 1 (HBA1) delay times
80	XT	CT2 ratio
81	ZG	CT2 assignment
82	NG	Heater break alarm 2 (HBA2) type
83	DF	Number of heater break alarm 2 (HBA2) delay times
84	XN	Hot/Cold start
85	SX	Start determination point
86	KM	External input type
87	MC	Master channel selection
88	XL	SV tracking
89	OT	MV transfer function

Address	Identifier	Description
8A	XE	Control action
8B	PK	Integral/derivative time decimal point position
8C	KA	Derivative term operating factor
8D	KB	Undershoot suppression factor
8E	DG	Derivative gain
8F	IV	ON/OFF action differential gap (upper)
90	IW	ON/OFF action differential gap (lower)
91	WH	Action (high) at input error
92	WL	Action (low) at input error
93	OE	Manipulated output value at input error
94	OF	Manipulated output value (MV1) at STOP mode
95	OG	Manipulated output value (MV2) at STOP mode
96	PH	Output change rate limiter (up) [MV1]
97	PL	Output change rate limiter (down) [MV1]
98	OH	Output limiter (high) [MV1]
99	OL	Output limiter (low) [MV1]
9A	PX	Output change rate limiter (up) [MV2]
9B	PY	Output change rate limiter (down) [MV2]
9C	OX	Output limiter (high) [MV2]
9D	OY	Output limiter (low) [MV2]
9E	PF	Power feed forward selection
9F	PZ	Power feed forward gain
A0	GB	AT bias
A1	G3	AT cycles
A2	OP	Output value with AT turned on
A3	OQ	Output value with AT turned off
A4	GH	AT differential gap time
A5	KC	Proportional band adjusting factor [heat-side]
A6	KD	Integral time adjusting factor [heat-side]
A7	KE	Derivative time adjusting factor [heat-side]
A8	KF	Proportional band adjusting factor [cool-side]
A9	KG	Integral time adjusting factor [cool-side]
AA	KH	Derivative time adjusting factor [cool-side]
AB	P6	Proportional band limiter (high) [heat-side]
AC	P7	Proportional band limiter (low) [heat-side]
AD	I6	Integral time limiter (high) [heat-side]
AE	I7	Integral time limiter (low) [heat-side]
AF	D6	Derivative time limiter (high) [heat-side]
B0	D7	Derivative time limiter (low) [heat-side]
B1	P8	Proportional band limiter (high) [cool-side]
B2	P9	Proportional band limiter (low) [cool-side]
B3	I8	Integral time limiter (high) [cool-side]
B4	I9	Integral time limiter (low) [cool-side]
B5	D8	Derivative time limiter (high) [cool-side]
B6	D9	Derivative time limiter (low) [cool-side]
B7	V2	Open/Close output neutral zone
B8	VH	Open/Close output differential gap
B9	SY	Action at feedback resistance (FBR) input error
BA	FV	Feedback adjustment
BB	TN	Control motor time
BC	OI	Integrated output limiter
BD	VS	Valve action at STOP

Address	Identifier	Description
BE	ST	Startup tuning (ST)
BF	KI	ST proportional band adjusting factor
C0	KJ	ST integral time adjusting factor
C1	KK	ST derivative time adjusting factor
C2	SU	ST start condition
C3	Y7	Automatic temperature rise group
C4	Y8	Automatic temperature rise learning
C5	RT	Automatic temperature rise dead time
C6	R2	Automatic temperature rise gradient data
C7	GQ	RUN/STOP group
C8	HU	Setting change rate limiter unit time
C9	RU	Soak time unit
CA	SH	Setting limiter (high)
CB	SL	Setting limiter (low)
CC	TS	PV transfer function
CD	DU	PV flashing display at input error
CE	VR	ROM version monitor (1-4 character)
CF	VR	ROM version monitor (5-8 character)

**IMPORTANT**

- Setting "Use system data area" to GP-Pro EX system area result in improper operation. Do not set "Use system data area."

**NOTE**

- System area setting that can be used for the temperature controller is reading area size only. Please refer to the GP-Pro EX Reference Manual for system data area.  
Cf. GP-Pro EX Reference Manual "LS Area (Direct Access Method Area)"
- Please refer to the precautions on manual notation for icons in the table.  
☞ "Manual Symbols and Terminology"
- Even if non-existing address is used, there are cases when read error is not indicated. In this case, zero (0) is kept for read out data. On the other hand, writing error is indicated.



## 6.3 HA Series

 This address can be specified as system data area.

Device	Bit Address	Word Address	32 bits	Notes
Communication identifier	0000.00-00E8.1F	0000-00E8		*1 *2 *3

- \*1 There are cases for which writing is not available depending on the device address. Check the identifying attributes of the external device's manual before use.
- \*2 When bit is written, the indicator reads the corresponding word address of external device, assign a bit to the read word address, and return to the external device. There are cases when correct data cannot be written if the word address is written using a ladder program, while the indicator reads data of the external device and sends it back.
- \*3 32-bit device

<Communication identifier list>

Address	Identifier	Description
00	M1	Input 1 measured value (PV1)
01	M0	Input 2 measured value (PV2)
02	M2	Feedback resistance input monitor
03	M3	Current transformer 1 (CT1) input value monitor
04	M4	Current transformer 2 (CT2) input value monitor
05	MS	Input 1 setting-value(SV1) monitor
06	MT	Input 2 setting-value(SV1) monitor
07	S2	Remote setting (RS) input value monitor
08	KH	Cascade monitor
09	B1	Burnout state monitor of input 1
0A	B0	Burnout state monitor of input 2
0B	B2	Burnout state monitor of feedback resistance input
0C	AA	Event 1 state monitor
0D	AB	Event 2 state monitor
0E	AC	Event 3 state monitor
0F	AD	Event 4 state monitor
10	AE	Heater break alarm 1 (HBA1) state
11	AF	Heater break alarm 2 (HBA1) state
12	O1	Manipulated output value (MV1) of input 1
13	O0	Manipulated output value (MV2) of input 2
14	ER	Error code
15	L1	Event input(DI) state
16	L0	Operation mode state
17	TR	Memory area soak time monitor
18	G1	PID/AT transfer of input 1
19	G0	PID/AT transfer of input 2
1A	J1	Auto/Manual transfer of input 1
1B	J0	Auto/Manual transfer of input 2
1C	C1	Remote/Local transfer
1D	SR	RUN/STOP transfer
1E	ZA	Memory area transfer
1F	A1	Event 1 set value
20	A2	Event 2 set value
21	A3	Event 3 set value
22	A5	Control loop break alarm 1 (LBA1) time

Address	Identifier	Description
23	N1	LBA1 deadband
24	A4	Event 4 set value
25	A6	Control loop break alarm 2 (LBA2) time
26	N2	LBA2 deadband
27	S1	Set value (SV1) of input 1
28	P1	Proportional band of input 1
29	I1	Integral time of input 1
2A	D1	Derivative time of input 1
2B	CA	Control response parameter of input 1
2C	S0	Set value (SV2) of input 2
2D	P0	Proportional band of input 2
2E	I0	Integral time of input 2
2F	D0	Derivative time of input 2
30	C9	Control response parameter of input 2
31	HH	Setting change rate limiter (up) of input 1
32	HL	Setting change rate limiter (down) of input 1
33	HX	Setting change rate limiter (up) of input 2
34	HY	Setting change rate limiter (down) of input 2
35	TM	Area soak time
36	LP	Link area number
37	A7	Heater break alarm 1 (HBA1) set value
38	A8	Heater break alarm 2 (HBA2) set value
39	PB	PV bias of input 1
3A	F1	PV digital filter of input 1
3B	PR	PV ratio of input 1
3C	DP	PV low input cut-off of input 1
3D	T0	Proportional cycle of input 1
3E	ON	Manual output value of input 1
3F	PA	PV bias of input 2
40	F0	PV digital filter of input 2
41	PQ	PV ratio of input 2
42	DO	PV low input cut-off of input 2
43	T2	Proportional cycle of input 2
44	OM	Manual output value of input 2
45	LK	Set lock level
46	EM	EEPROM status
47	EB	EEPROM mode
48	NE	Heater break determination point 1
49	NF	Heater melting determination point 1
4A	NH	Heater break determination point 2
4B	NI	Heater melting determination point 2
4C	HP	Not used
4D	HQ	Not used
4E	HR	Not used
4F	FP	Not used
50	FQ	Not used
51	FR	Not used
52	IL	Not used
53	AZ	Not used
54	FS	Not used
55	DX	STOP display selection
56	DA	Bar graph display selection

Address	Identifier	Description
57	DE	Bar graph display resolution
58	DK	Auto/manual change key operation selection (A/M)
59	DL	Remote/local change key operation selection (R/L)
5A	DM	RUN/STOP change key operation selection (R/S)
5B	XI	Input type selection of input 1
5C	PU	Display unit selection of input 1
5D	XU	Decimal-point position selection of input 1
5E	XV	Input scale high-limit of input 1
5F	XW	Input scale low-limit of input 1
60	AV	Input abnormality determination point (High limit) of input 1
61	AW	Input abnormality determination point (Low limit) of input 1
62	BS	Burnout direction of input 1
63	XH	Square root extraction selection of input 1
64	JT	Power supply frequency selection
65	XJ	Input type selection of input 2
66	PT	Display unit selection of input 2
67	XT	Decimal-point position selection of input 2
68	XX	Input scale high-limit of input 2
69	XY	Input scale low-limit of input 2
6A	AX	Input abnormality determination point (High limit) of input 2
6B	AY	Input abnormality determination point (Low limit) of input 2
6C	BR	Burnout direction of input 2
6D	XG	Square root extraction selection of input 2
6E	H2	Event input logic selection
6F	E0	Output logic selection
70	TD	Output 1 timer setting
71	TG	Output 2 timer setting
72	TH	Output 3 timer setting
73	TI	Output 4 timer setting
74	TJ	Output 5 timer setting
75	LA	Transmission output 1 type selection
76	HV	Transmission output 1 scale high
77	HW	Transmission output 1 scale low
78	LB	Transmission output 2 type selection
79	CV	Transmission output 2 scale high
7A	CW	Transmission output 2 scale low
7B	LC	Transmission output 3 type selection
7C	EV	Transmission output 3 scale high
7D	EW	Transmission output 3 scale low
7E	XA	Event 1 type selection
7F	WA	Event 1 hold action
80	HA	Event 1 differential gap
81	OA	Event 1 action at input error
82	FA	Event 1 assignment
83	XB	Event 2 type selection
84	WB	Event 2 hold action
85	HB	Event 2 differential gap
86	OB	Event 2 action at input error
87	FB	Event 2 assignment
88	XC	Event 3 type selection
89	WC	Event 3 hold action
8A	HC	Event 3 differential gap

Address	Identifier	Description
8B	OC	Event 3 action at input error
8C	FC	Event 3 assignment
8D	XD	Event 4 type selection
8E	WD	Event 4 hold action
8F	HD	Event 4 differential gap
90	OD	Event 4 action at input error
91	FD	Event 4 assignment
92	XR	CT1 ratio
93	ZF	CT1 assignment
94	XS	CT2 ratio
95	ZG	CT2 assignment
96	XN	Hot/Cold start selection
97	KM	Usage selection of input 2
98	RR	Cascade ratio
99	RB	Cascade bias
9A	XL	SV tracking selection
9B	XE	Control action selection of input 1
9C	PK	Integral/derivative time decimal point position selection of input 1
9D	DG	Derivative gain of input 1
9E	IV	ON/OFF action differential gap (upper) of input 1
9F	IW	ON/OFF action differential gap (lower) of input 1
A0	WH	Action (high) at input error of input 1
A1	WL	Action (low) at input error of input 1
A2	OE	Manipulated output value at input error of input 1
A3	PH	Output change rate limiter (up) of input 1
A4	PL	Output change rate limiter (down) of input 1
A5	OH	Output limiter (high) of input 1
A6	OL	Output limiter (low) of input 1
A7	PF	Power feed forward selection of input 1
A8	XF	Control action selection of input 2
A9	PJ	Integral/derivative time decimal point position selection of input 2
AA	DJ	Derivative gain of input 2
AB	IX	ON/OFF action differential gap (upper) of input 2
AC	IY	ON/OFF action differential gap (lower) of input 2
AD	WX	Action (high) at input error of input 2
AE	WY	Action (low) at input error of input 2
AF	OF	Manipulated output value at input error of input 2
B0	PX	Output change rate limiter (up) of input 2
B1	PY	Output change rate limiter (down) of input 2
B2	OX	Output limiter (high) of input 2
B3	OY	Output limiter (low) of input 2
B4	PG	Power feed forward selection of input 2
B5	GB	AT bias of input 1
B6	G3	AT cycles of input 1
B7	GH	AT differential gap time of input 1
B8	GA	AT bias of input 2
B9	G2	AT cycles of input 2
BA	GG	AT differential gap time of input 2
BB	V2	Open/Close output neutral zone
BC	VH	Open/Close output differential gap
BD	SY	Action at feedback resistance (FBR) input error
BE	FV	Feedback adjustment

Address	Identifier	Description
BF	HU	Setting change rate limiter unit time
C0	RU	Soak time unit
C1	SH	Setting limiter (high) of input 1
C2	SL	Setting limiter (low) of input 1
C3	ST	Setting limiter (high) of input 2
C4	SU	Setting limiter (low) of input 2
C5	VR	ROM version (1-4 character)
C6	UT	Integrated operating time
C7	Hp	Holding peak value ambient temperature
C8	HM	Power feed forward input value
C9	VG	Feedback resistance (FBR) input assignment
CA	PZ	Power feed forward gain of input 1
CB	PW	Power feed forward gain of input 2
CC	ND	Heater break alarm 1 (HBA1) type
CD	DH	Number of heater break alarm 1 (HBA1) delay times
CE	NG	Heater break alarm 2 (HBA2) type
CF	DF	Number of heater break alarm 2 (HBA2) delay times
D0	LY	Alarm (ALM) lamp lighting condition 1
D1	LZ	Alarm (ALM) lamp lighting condition 2
D2	HT	Not used
D3	FT	Not used
D4	OG	Not used
D5	LI	Not used
D6	OR	Not used
D7	TS	Not used
D8	US	Not used
D9	RH	Not used
DA	RL	Not used
DB	RP	Not used
DC	JI	Not used
DD	JJ	Not used
DE	OI	Not used
DF	OJ	Not used
E0	QA	Not used
E1	OT	Not used
E2	OU	Not used
E3	MY	Not used
E4	NY	Not used
E5	MZ	Not used
E6	NZ	Not used
E7	VR	ROM version (1-4 character)
E8	VR	ROM version (5-7 character)

**IMPORTANT**

- Setting "Use system data area" to GP-Pro EX system area result in improper operation. Do not set "Use system data area."

**NOTE**

- System area setting that can be used for the temperature controller is reading area size only. Please refer to the GP-Pro EX Reference Manual for system data area.  
Cf. GP-Pro EX Reference Manual "LS Area (Direct Access Method Area)"
- Please refer to the precautions on manual notation for icons in the table.
  - ☞ "Manual Symbols and Terminology"
- Even if non-existing address is used, there are cases when read error is not indicated. In this case, zero (0) is kept for read out data. On the other hand, writing error is indicated.

## 6.4 MA Series

 This address can be specified as system data area.

Device	Bit Address	Word Address	32 bits	Notes
Communication identifier	0000.0-002A.F	0000-002A		*1 *2

- \*1 There are cases for which writing is not available depending on the device address. Check the identifying attributes of the external device's manual before use.
- \*2 When bit is written, the indicator reads the corresponding word address of external device, assign a bit to the read word address, and return to the external device. There are cases when correct data cannot be written if the word address is written using a ladder program, while the indicator reads data of the external device and sends it back.

## &lt;Communication identifier list&gt;

Address	Identifier	Description
00	M1	Measured value (PV)
01	M2	Current transformer 1 input value
02	M3	Current transformer 2 input value
03	MS	Set value monitor
04	B1	Burnout
05	AA	Alarm 1 status
06	AB	Alarm 2 status
07	AC	Alarm 3 status
08	AJ	Output status
09	O1	Manipulated output value
0A	O2	Cool-side manipulated output value
0B	ER	Error code
0C	L1	DI status
0D	ZA	Memory area number selection
0E	S1	Set value (SV)
0F	A1	Alarm 1
10	N1	Control loop break alarm deadband (LBD)
11	A2	Alarm 2
12	N2	Heater break alarm 2 (HBA2)
13	A3	Alarm 3
14	P1	Proportional band
15	P2	Cool-side proportional band
16	I1	Integral time
17	D1	Derivative time
18	W1	Anti-reset windup
19	V1	Overlap/deadband
1A	HH	Setting change rate limiter
1B	EI	Used/unused of channels
1C	SR	RUN/STOP transfer
1D	G1	PID/AT selection
1E	PB	PV bias
1F	F1	Digital filter
20	T0	Proportioning cycle time
21	T1	Cool-side proportioning cycle time
22	TL	Scan interval time

Address	Identifier	Description
23	IP	Device address
24	IR	Communication speed
25	IQ	Data bit configuration
26	IT	Interval time
27	EB	EEPROM storage mode
28	EM	EEPROM storage status
29	LK	Lock level 1
2A	LL	Lock level 2

**IMPORTANT**

- Setting "Use system data area" to GP-Pro EX system area result in improper operation. Do not set "Use system data area."

**NOTE**

- System area setting that can be used for the temperature controller is reading area size only. Please refer to the GP-Pro EX Reference Manual for system data area.  
Cf. GP-Pro EX Reference Manual "LS Area (Direct Access Method Area)"
- Please refer to the precautions on manual notation for icons in the table.
  - ☞ "Manual Symbols and Terminology"
- Even if non-existing address is used, there are cases when read error is not indicated. In this case, zero (0) is kept for read out data. On the other hand, writing error is indicated.



## 6.5 SRV Series

 This address can be specified as system data area.

Device	Bit Address	Word Address	32 bits	Notes
Communication identifier	0000.0-0085.1F	0000-0085		*1 *2 *3

- \*1 There are cases for which writing is not available depending on the device address. Check the identifying attributes of the external device's manual before use.
- \*2 When bit is written, the indicator reads the corresponding word address of external device, assign a bit to the read word address, and return to the external device. There are cases when correct data cannot be written if the word address is written using a ladder program, while the indicator reads data of the external device and sends it back.
- \*3 32-bit device

## &lt;Communication identifier list&gt;

Address	Identifier	Description
00	M1(ch1)	CH1 Measured-value (PV)
01	M1(ch2)	CH2 Measured-value (PV)
02	AJ(ch1)	CH1 Overall event status
03	AJ(ch2)	CH2 Overall event status
04	B1(ch1)	CH1 Burnout state
05	B1(ch2)	CH2 Burnout state
06	AA(ch1)	CH1 Event 1 state
07	AA(ch2)	CH2 Event 1 state
08	AB(ch1)	CH1 Event 2 state
09	AB(ch2)	CH2 Event 2 state
0A	AC(ch1)	CH1 Heater break alarm (HBA) state
0B	AC(ch2)	CH2 Heater break alarm (HBA) state
0C	AP(ch1)	CH1 Control loop break alarm (LBA) state
0D	AP(ch2)	CH2 Control loop break alarm (LBA) state
0E	O1(ch1)	CH1 Manipulated output value[heat-side]
0F	O1(ch2)	CH2 Manipulated output value[heat-side]
10	O2(ch1)	CH1 Manipulated output value[cool-side]
11	O2(ch2)	CH2 Manipulated output value[cool-side]
12	M3(ch1)	CH1 CT input measured value
13	M3(ch2)	CH2 CT input measured value
14	MS(ch1)	CH1 Set-value monitoring
15	MS(ch2)	CH2 Set-value monitoring
16	ER	Error code
17	HE(ch1)	CH1 Temperature rise completion status
18	HE(ch2)	CH2 Temperature rise completion status
19	S1(ch1)	CH1 Set value (SV)
1A	S1(ch2)	CH2 Set value (SV)
1B	P1(ch1)	CH1 Proportional band [heat-side]
1C	P1(ch2)	CH2 Proportional band [heat-side]
1D	P2(ch1)	CH1 Proportional band [cool-side]
1E	P2(ch2)	CH2 Proportional band [cool-side]
1F	I1(ch1)	CH1 Integral time
20	I1(ch2)	CH2 Integral time
21	D1(ch1)	CH1 Derivative time

Address	Identifier	Description
22	D1(ch2)	CH2 Derivative time
23	CA(ch1)	CH1 Control response designation parameter
24	CA(ch2)	CH2 Control response designation parameter
25	V1(ch1)	CH1 Overlap/Deadband
26	V1(ch2)	CH2 Overlap/Deadband
27	HH(ch1)	CH1 Setting change rate limiter
28	HH(ch2)	CH2 Setting change rate limiter
29	PB(ch1)	CH1 PV bias
2A	PB(ch2)	CH2 PV bias
2B	A1(ch1)	CH1 Event 1 setting value
2C	A1(ch2)	CH2 Event 1 setting value
2D	A2(ch1)	CH1 Event 2 setting value
2E	A2(ch2)	CH2 Event 2 setting value
2F	EI(ch1)	CH1 Operation mode
30	EI(ch2)	CH2 Operation mode
31	G1(ch1)	CH1 PID/AT transfer
32	G1(ch2)	CH2 PID/AT transfer
33	J1(ch1)	CH1 Auto/Manual transfer
34	J1(ch2)	CH2 Auto/Manual transfer
35	ON(ch1)	CH1 Manual output value
36	ON(ch2)	CH2 Manual output value
37	OH(ch1)	CH1 Output limiter (high)
38	OH(ch2)	CH2 Output limiter (high)
39	OL(ch1)	CH1 Output limiter (low)
3A	OL(ch2)	CH2 Output limiter (low)
3B	T0(ch1)	CH1 Proportioning cycle (heat-side)
3C	T0(ch2)	CH2 Proportioning cycle (heat-side)
3D	T1(ch1)	CH1 Proportioning cycle (cool-side)
3E	T1(ch2)	CH2 Proportioning cycle (cool-side)
3F	F1(ch1)	CH1 digital filter
40	F1(ch2)	CH2 digital filter
41	A3(ch1)	CH1 Heater break alarm (HBA) set value
42	A3(ch2)	CH2 Heater break alarm (HBA) set value
43	DH(ch1)	CH1 Number of heater break alarm (HBA) delay times
44	DH(ch2)	CH2 Number of heater break alarm (HBA) delay times
45	SR	Control RUN/STOP transfer
46	AV(ch1)	CH1 Input error determination point (high)
47	AV(ch2)	CH2 Input error determination point (high)
48	AW(ch1)	CH1 Input error determination point (low)
49	AW(ch2)	CH2 Input error determination point (low)
4A	WH(ch1)	CH1 Action (high) at input error
4B	WH(ch2)	CH2 Action (high) at input error
4C	WL(ch1)	CH1 Action (low) at input error
4D	WL(ch2)	CH2 Action (low) at input error
4E	OE(ch1)	CH1 Manipulated output value at input error
4F	OE(ch2)	CH2 Manipulated output value at input error
50	GH(ch1)	CH1 AT differential gap time
51	GH(ch2)	CH2 AT differential gap time
52	GB(ch1)	CH1 AT bias
53	GB(ch2)	CH2 AT bias
54	XH	Event LED mode set
55	HP(ch1)	CH1 Control loop break alarm (LBA) usage selection

Address	Identifier	Description
56	HP(ch2)	CH2 Control loop break alarm (LBA) usage selection
57	C6(ch1)	CH1 Control loop break alarm (LBA) time
58	C6(ch2)	CH2 Control loop break alarm (LBA) time
59	V2(ch1)	CH1 Control loop break alarm (LBA) deadband
5A	V2(ch2)	CH2 Control loop break alarm (LBA) deadband
5B	E1	DI set
5C	L1	DI status
5D	QA	DO1 set
5E	QB	DO2 set
5F	Q1	DO status
60	AR	Event interlock release
61	HD(ch1)	CH1 Temperature rise completion range
62	HD(ch2)	CH2 Temperature rise completion range
63	T3(ch1)	CH1 Temperature rise completion soak time
64	T3(ch2)	CH2 Temperature rise completion soak time
65	IN	Initial set mode
66	XI(ch1)	CH1 Input range number
67	XI(ch2)	CH2 Input range number
68	XV(ch1)	CH1 Input scale high
69	XV(ch2)	CH2 Input scale high
6A	XW(ch1)	CH1 Input scale low
6B	XW(ch2)	CH2 Input scale low
6C	XU(ch1)	CH1 Input range decimal point position
6D	XU(ch2)	CH2 Input range decimal point position
6E	PU(ch1)	CH1 Temperature unit selection
6F	PU(ch2)	CH2 Temperature unit selection
70	XE(ch1)	CH1 Control type
71	XE(ch2)	CH2 Control type
72	IV(ch1)	CH1 ON/OFF action differential gap (upper)
73	IV(ch2)	CH2 ON/OFF action differential gap (upper)
74	IW(ch1)	CH1 ON/OFF action differential gap (lower)
75	IW(ch2)	CH2 ON/OFF action differential gap (lower)
76	HA(ch1)	CH1 Event 1 differential gap
77	HA(ch2)	CH2 Event 1 differential gap
78	HB(ch1)	CH1 Event 2 differential gap
79	HB(ch2)	CH2 Event 2 differential gap
7A	XA(ch1)	CH1 Event 1 type
7B	XA(ch2)	CH2 Event 1 type
7C	XB(ch1)	CH1 Event 2 type
7D	XB(ch2)	CH2 Event 2 type
7E	WA(ch1)	CH1 Event 1 action
7F	WA(ch2)	CH2 Event 1 action
80	WB(ch1)	CH1 Event 2 action
81	WB(ch2)	CH2 Event 2 action
82	TD(ch1)	CH1 Event delay timer
83	TD(ch2)	CH2 Event delay timer
84	ZX	Transmission transfer time setting
85	X2	Transfer mode hold setting

**IMPORTANT**

- Setting "Use system data area" to GP-Pro EX system area result in improper operation. Do not set "Use system data area."

**NOTE**

- System area setting that can be used for the temperature controller is reading area size only. Please refer to the GP-Pro EX Reference Manual for system data area.  
Cf. GP-Pro EX Reference Manual "LS Area (Direct Access Method Area)"
- Please refer to the precautions on manual notation for icons in the table.
  - ☞ "Manual Symbols and Terminology"
- Even if non-existing address is used, there are cases when read error is not indicated. In this case, zero (0) is kept for read out data. On the other hand, writing error is indicated.

## 6.6 SRX Series

 This address can be specified as system data area.

Device	Bit Address	Word Address	32 bits	Notes
Communication identifier	0000.00-008C.1F	0000-008C		*1 *2 *3

- \*1 There are cases for which writing is not available depending on the device address. Check the identifying attributes of the external device's manual before use.
- \*2 When bit is written, the indicator reads the corresponding word address of external device, assign a bit to the read word address, and return to the external device. There are cases when correct data cannot be written if the word address is written using a ladder program, while the indicator reads data of the external device and sends it back.
- \*3 32-bit device

## &lt;Communication identifier list&gt;

Address	Identifier	Description
00	M1(ch1)	CH1 Measured-value (PV)
01	M1(ch2)	CH2 Measured-value (PV)
02	AJ(ch1)	CH1 Overall event status
03	AJ(ch2)	CH2 Overall event status
04	B1(ch1)	CH1 Burnout state
05	B1(ch2)	CH2 Burnout state
06	AA(ch1)	CH1 Event 1 state
07	AA(ch2)	CH2 Event 1 state
08	AB(ch1)	CH1 Event 2 state
09	AB(ch2)	CH2 Event 2 state
0A	AC(ch1)	CH1 Heater break alarm (HBA) state
0B	AC(ch2)	CH2 Heater break alarm (HBA) state
0C	AP(ch1)	CH1 Control loop break alarm (LBA) state
0D	AP(ch2)	CH2 Control loop break alarm (LBA) state
0E	O1(ch1)	CH1 Manipulated output value
0F	O1(ch2)	CH2 Manipulated output value
10	M3(ch1)	CH1 CT input measured value
11	M3(ch2)	CH2 CT input measured value
12	MS(ch1)	CH1 Set-value monitoring
13	MS(ch2)	CH2 Set-value monitoring
14	ER	Error code
15	S1(ch1)	CH1 Set value (SV)
16	S1(ch2)	CH2 Set value (SV)
17	PI(ch1)	CH1 Proportional band
18	PI(ch2)	CH2 Proportional band
19	I1(ch1)	CH1 Integral time
1A	I1(ch2)	CH2 Integral time
1B	D1(ch1)	CH1 Derivative time
1C	D1(ch2)	CH2 Derivative time
1D	CA(ch1)	CH1 Control response designation parameter
1E	CA(ch2)	CH2 Control response designation parameter
1F	PB(ch1)	CH1 PV bias
20	PB(ch2)	CH2 PV bias
21	A1(ch1)	CH1 Event 1 setting value

Address	Identifier	Description
22	A1(ch2)	CH2 Event 1 setting value
23	A2(ch1)	CH1 Event 2 setting value
24	A2(ch2)	CH2 Event 2 setting value
25	EI(ch1)	CH1 Operation mode
26	EI(ch2)	CH2 Operation mode
27	G1(ch1)	CH1 PID/AT transfer
28	G1(ch2)	CH2 PID/AT transfer
29	J1(ch1)	CH1 Auto/Manual transfer
2A	J1(ch2)	CH2 Auto/Manual transfer
2B	ON(ch1)	CH1 Manual output value
2C	ON(ch2)	CH2 Manual output value
2D	OH(ch1)	CH1 Output limiter (high)
2E	OH(ch2)	CH2 Output limiter (high)
2F	OL(ch1)	CH1 Output limiter (low)
30	OL(ch2)	CH2 Output limiter (low)
31	T0(ch1)	CH1 Proportioning cycle
32	T0(ch2)	CH2 Proportioning cycle
33	F1(ch1)	CH1 digital filter
34	F1(ch2)	CH2 digital filter
35	A3(ch1)	CH1 Heater break alarm (HBA) set value
36	A3(ch2)	CH2 Heater break alarm (HBA) set value
37	DH(ch1)	CH1 Number of heater break alarm (HBA) delay times
38	DH(ch2)	CH2 Number of heater break alarm (HBA) delay times
39	XN(ch1)	CH1 Hot/Cold start selection
3A	XN(ch2)	CH2 Hot/Cold start selection
3B	SX(ch1)	CH1 Start determination point
3C	SX(ch2)	CH2 Start determination point
3D	SR	Control RUN/STOP transfer
3E	AV(ch1)	CH1 Input error determination point (high)
3F	AV(ch2)	CH2 Input error determination point (high)
40	AW(ch1)	CH1 Input error determination point (low)
41	AW(ch2)	CH2 Input error determination point (low)
42	WH(ch1)	CH1 Action (high) at input error
43	WH(ch2)	CH2 Action (high) at input error
44	WL(ch1)	CH1 Action (low) at input error
45	WL(ch2)	CH2 Action (low) at input error
46	OE(ch1)	CH1 Manipulated output value at input error
47	OE(ch2)	CH2 Manipulated output value at input error
48	GH(ch1)	CH1 AT differential gap time
49	GH(ch2)	CH2 AT differential gap time
4A	GB(ch1)	CH1 AT bias
4B	GB(ch2)	CH2 AT bias
4C	C1	Remote/Local transfer
4D	XH	Event LED mode set
4E	E1(ch1)	CH1 Digital input setting 1 (RESET)
4F	E1(ch2)	CH2 Digital input setting 1 (RESET)
50	E2(ch1)	CH1 Digital input setting 2 (RUN)
51	E2(ch2)	CH2 Digital input setting 2 (RUN)
52	E3(ch1)	CH1 Digital input setting 3 (FIX)
53	E3(ch2)	CH2 Digital input setting 3 (FIX)
54	E4(ch1)	CH1 Digital input setting 4 (MAN)
55	E4(ch2)	CH2 Digital input setting 4 (MAN)

Address	Identifier	Description
56	E5(ch1)	CH1 Digital input setting 5 (HOLD)
57	E5(ch2)	CH2 Digital input setting 5 (HOLD)
58	E6(ch1)	CH1 Digital input setting 6 (STEP)
59	E6(ch2)	CH2 Digital input setting 6 (STEP)
5A	E7(ch1)	CH1 Digital input setting 7 (Program pattern selection)
5B	E7(ch2)	CH2 Digital input setting 7 (Program pattern selection)
5C	E8(ch1)	CH1 Digital input setting 8 (AT/PID)
5D	E8(ch2)	CH2 Digital input setting 8 (AT/PID)
5E	HP(ch1)	CH1 Control loop break alarm (LBA) usage selection
5F	HP(ch2)	CH2 Control loop break alarm (LBA) usage selection
60	C6(ch1)	CH1 Control loop break alarm (LBA) time
61	C6(ch2)	CH2 Control loop break alarm (LBA) time
62	V2(ch1)	CH1 Control loop break alarm (LBA) deadband
63	V2(ch2)	CH2 Control loop break alarm (LBA) deadband
64	PK(ch1)	CH1 Integral/Derivative time decimal point position
65	PK(ch2)	CH2 Integral/Derivative time decimal point position
66	IN	Initial set mode
67	XI(ch1)	CH1 Input range number
68	XI(ch2)	CH2 Input range number
69	XV(ch1)	CH1 Input scale high
6A	XV(ch2)	CH2 Input scale high
6B	XW(ch1)	CH1 Input scale low
6C	XW(ch2)	CH2 Input scale low
6D	XU(ch1)	CH1 Input range decimal point position
6E	XU(ch2)	CH2 Input range decimal point position
6F	PU(ch1)	CH1 Temperature unit selection
70	PU(ch2)	CH2 Temperature unit selection
71	XE(ch1)	CH1 Control type
72	XE(ch2)	CH2 Control type
73	IV(ch1)	CH1 ON/OFF action differential gap (upper)
74	IV(ch2)	CH2 ON/OFF action differential gap (upper)
75	IW(ch1)	CH1 ON/OFF action differential gap (lower)
76	IW(ch2)	CH2 ON/OFF action differential gap (lower)
77	HA(ch1)	CH1 Event 1 differential gap
78	HA(ch2)	CH2 Event 1 differential gap
79	HB(ch1)	CH1 Event 2 differential gap
7A	HB(ch2)	CH2 Event 2 differential gap
7B	XA(ch1)	CH1 Event 1 type
7C	XA(ch2)	CH2 Event 1 type
7D	XB(ch1)	CH1 Event 2 type
7E	XB(ch2)	CH2 Event 2 type
7F	WA(ch1)	CH1 Event 1 action
80	WA(ch2)	CH2 Event 1 action
81	WB(ch1)	CH1 Event 2 action
82	WB(ch2)	CH2 Event 2 action
83	DF(ch1)	CH1 Event delay frequency
84	DF(ch2)	CH2 Event delay frequency
85	ZX	Transmission transfer time setting
86	XP(ch1)	CH1 Segment time unit setting
87	XP(ch2)	CH2 Segment time unit setting
88	X2	Transfer mode hold setting
89	PH(ch1)	CH1 Change rate limiter(up) of output

Address	Identifier	Description
8A	PH(ch2)	CH2 Change rate limiter(up) of output
8B	PL(ch1)	CH1 Change rate limiter(down) of output
8C	PL(ch2)	CH2 Change rate limiter(down) of output

**IMPORTANT**

- Setting "Use system data area" to GP-Pro EX system area result in improper operation. Do not set "Use system data area."

**NOTE**

- System area setting that can be used for the temperature controller is reading area size only. Please refer to the GP-Pro EX Reference Manual for system data area.  
Cf. GP-Pro EX Reference Manual "LS Area (Direct Access Method Area)"
- Please refer to the precautions on manual notation for icons in the table.
  - ☞ "Manual Symbols and Terminology"
- Even if non-existing address is used, there are cases when read error is not indicated. In this case, zero (0) is kept for read out data. On the other hand, writing error is indicated.



## 6.7 SA Series

 This address can be specified as system data area.

Device	Bit Address	Word Address	32 bits	Notes
Communication identifier	0000.0-001E.F	0000-001E		*1 *2

- \*1 There are cases for which writing is not available depending on the device address. Check the identifying attributes of the external device's manual before use.
- \*2 When bit is written, the indicator reads the corresponding word address of external device, assign a bit to the read word address, and return to the external device. There are cases when correct data cannot be written if the word address is written using a ladder program, while the indicator reads data of the external device and sends it back.

## &lt;Communication identifier list&gt;

Address	Identifier	Description
00	M1	Measured value(PV)
01	B1	Burnout
02	AA	Alarm 1 status
03	AB	Alarm 2 status
04	O1	Heat-side manipulated output value
05	O2	Cool-side manipulated output value
06	ER	Error code
07	SR	RUN/STOP function
08	G1	Autotuning
09	G2	Self-tuning
0A	S1	Set value (SV)
0B	A1	Alarm 1 set value
0C	A2	Alarm 2 set value
0D	A5	Control loop break alarm
0E	A6	Control loop break alarm deadband
0F	P1	Heat-side proportional band (P)
10	I1	Integral time (I)
11	D1	Derivative time (D)
12	W1	Anti-reset windup
13	T0	Heat-side proportioning cycle time
14	P2	Cool-side proportional band
15	V1	Overlap/deadband
16	T1	Cool-side proportioning cycle time
17	PB	PV bias
18	F1	Digital filter
19	LK	Set data lock function
1A	EB	EEPROM storage mode
1B	EM	EEPROM storage status
1C	LA	Analog output specification selection
1D	HV	Analog output scale high
1E	HW	Analog output scale low

**IMPORTANT**

- Setting "Use system data area" to GP-Pro EX system area result in improper operation. Do not set "Use system data area."

**NOTE**

- System area setting that can be used for the temperature controller is reading area size only. Please refer to the GP-Pro EX Reference Manual for system data area.  
Cf. GP-Pro EX Reference Manual "LS Area (Direct Access Method Area)"
- Please refer to the precautions on manual notation for icons in the table.
  - ☞ "Manual Symbols and Terminology"
- Even if non-existing address is used, there are cases when read error is not indicated. In this case, zero (0) is kept for read out data. On the other hand, writing error is indicated.

## 6.8 SR Mini HG(H-PCP-A/B) Series

 This address can be specified as system data area.

Device	Bit Address	Word Address	32 bits	Notes
Communication identifier	01/0000.0-01/00BD.F	01/0000-01/00BD	<b>[L/H]</b>	*1 *2 *3
	02/0000.0-02/00BD.F	02/0000-02/00BD		
	03/0000.0-03/00BD.F	03/0000-03/00BD		
	04/0000.0-04/00BD.F	04/0000-04/00BD		
	05/0000.0-05/00BD.F	05/0000-05/00BD		
	06/0000.0-06/00BD.F	06/0000-06/00BD		
	07/0000.0-07/00BD.F	07/0000-07/00BD		
	08/0000.0-08/00BD.F	08/0000-08/00BD		
	09/0000.0-09/00BD.F	09/0000-09/00BD		
	10/0000.0-10/00BD.F	10/0000-10/00BD		
	11/0000.0-11/00BD.F	11/0000-11/00BD		
	12/0000.0-12/00BD.F	12/0000-12/00BD		
	13/0000.0-13/00BD.F	13/0000-13/00BD		
	14/0000.0-14/00BD.F	14/0000-14/00BD		
	15/0000.0-15/00BD.F	15/0000-15/00BD		
	16/0000.0-16/00BD.F	16/0000-16/00BD		
	17/0000.0-17/00BD.F	17/0000-17/00BD		
	18/0000.0-18/00BD.F	18/0000-18/00BD		
	19/0000.0-19/00BD.F	19/0000-19/00BD		
	20/0000.0-20/00BD.F	20/0000-20/00BD		

\*1 There are cases for which writing is not available depending on the device address. Check the identifying attributes of the external device's manual before use.

\*2 When bit is written, the indicator reads the corresponding word address of external device, assign a bit to the read word address, and return to the external device. There are cases when correct data cannot be written if the word address is written using a ladder program, while the indicator reads data of the external device and sends it back.

\*3 It is necessary to specify the channel number for a module supported by the identifier about SR-Mini-HG (H-PCP-A/B) and SR-Mini-HG (H-PCP-J) Series.

01/0000

└ Channel number (Setting range: 01 to 20)

## &lt;Communication identifier list&gt;

Address	Identifier	Description
00	M1	Temperature measured value
01	AA	Alarm 1 status
02	AB	Alarm 2 status
03	B1	Burnout status
04	O1	Heat-side manipulated output value
05	O2	Cool-side manipulated output value
06	AC	Heater break alarm status
07	M3	Current transformer input measured value 1
08	M4	Current transformer input measured value 2
09	MS	Set value monitor
0A	HE	Temperature rise completion status
0B	ER	Error code
0C	G1	PID/AT transfer
0D	S1	Temperature set value
0E	P1	Heat-side proportional band
0F	P2	Cool-side proportional band
10	I1	Integral time
11	D1	Derivative time
12	V1	Overlap/deadband
13	CA	Control response parameters
14	A1	Alarm 1 set value
15	A2	Alarm 2 set value
16	A3	Heater break alarm set value 1
17	A4	Heater break alarm set value 2
18	EI	Operation mode transfer
19	T0	Heat-side proportioning cycle time
1A	T1	Cool-side proportioning cycle time
1B	PB	PV bias
1C	SR	Control RUN/STOP transfer
1D	IN	Initial setting mode
1E	ZA	Memory area number
1F	AR	Alarm interlock release
20	J1	Auto/Manual transfer
21	ON	Manual output value
22	HD	Temperature rise completion range
23	HS	Temperature rise completion trigger
24	T3	Temperature rise completion soak time
25	M5	AI measured value
26	AD	AI alarm 1 status
27	AE	AI alarm 2 status
28	A5	AI alarm 1 set value
29	A6	AI alarm 2 set value
2A	J1	AI zero point correction
2B	JJ	AI full scale correction
2C	NJ	AI operation mode transfer
2D	AP	Control loop break alarm (LBA) status
2E	HP	LBA use selection
2F	C6	LBA time
30	V2	LBA deadband
31	M6	AO output value monitor
32	S6	AO output set value

Address	Identifier	Description
33	XO	AO function selection
34	OY	AO corresponding channel setting
35	CV	AO zooming high limit
36	CW	AO zooming low limit
37	JK	AO zero point correction
38	JL	AO full scale correction
39	L1	DI module input status (DI-A module)
3A	C2	CC-Link selecting flag
3B	Q3	Event DO status (DO-C module)
3C	Q4	Event DO manual output value (DO-C module)
3D	A7	Event DO extension alarm set value
3E	KH	Cascade monitor
3F	KF	Cascade ON/OFF
40	KG	Cascade gain
41	KI	Cascade bias
42	M7	TI measured value
43	AF	TI alarm 1 status
44	AG	TI alarm 2 status
45	B2	TI burnout status
46	A8	TI alarm 1 set value
47	A9	TI alarm 2 set value
48	PC	TI PV bias
49	EJ	TI operation mode transfer
4A	L3	PCP module DI status
4B	L4	Event DI contact input monitor (DI-B module)
4C	L5	Event DI logic input monitor
4D	Q5	Event DI logic output monitor
4E	AH	CT module heater break alarm status
4F	AJ	Comprehensive alarm status
50	M8	Positioning monitor
51	V3	Positioning output neutral zone
52	TJ	Motor time
53	OS	Integrated output limite
54	OO	Manual positioning output value
55	C1	Local/Computer transfer
56	XI	Input range number [ <input type="checkbox"/> -TIO- <input type="checkbox"/> , H-CIO-A]
57	SH	Setting limiter (high) [ <input type="checkbox"/> -TIO- <input type="checkbox"/> , H-CIO-A]
58	SL	Setting limiter (low) [ <input type="checkbox"/> -TIO- <input type="checkbox"/> , H-CIO-A]
59	F1	Digital filter [ <input type="checkbox"/> -TIO- <input type="checkbox"/> , H-CIO-A]
5A	AV	Input error determination point (high) [ <input type="checkbox"/> -TIO- <input type="checkbox"/> , H-CIO-A]
5B	AW	Input error determination point (high) [ <input type="checkbox"/> -TIO- <input type="checkbox"/> , H-CIO-A]
5C	WH	Action at input error (high) [ <input type="checkbox"/> -TIO- <input type="checkbox"/> , H-CIO-A]
5D	WL	Action at input error (low) [ <input type="checkbox"/> -TIO- <input type="checkbox"/> , H-CIO-A]
5E	GB	AT bias [ <input type="checkbox"/> -TIO- <input type="checkbox"/> , H-CIO-A]
5F	HH	Setting change rate limiter (high) [ <input type="checkbox"/> -TIO- <input type="checkbox"/> , H-CIO-A]
60	OH	Output limiter (high) [For heat/cool control:Heat-side output limiter (high)] [ <input type="checkbox"/> -TIO- <input type="checkbox"/> , H-CIO-A]
61	OL	Output limiter (low) [For heat/cool control:Cool-side output limiter (high)] [ <input type="checkbox"/> -TIO- <input type="checkbox"/> , H-CIO-A]
62	IV	ON/OFF control differential gap (upper) [ <input type="checkbox"/> -TIO- <input type="checkbox"/> , H-CIO-A]
63	IW	ON/OFF control differential gap (lower) [ <input type="checkbox"/> -TIO- <input type="checkbox"/> , H-CIO-A]
64	OE	Manipulated output value at input error [ <input type="checkbox"/> -TIO- <input type="checkbox"/> , H-CIO-A]
65	PH	Output change rate limiter (up) [ <input type="checkbox"/> -TIO- <input type="checkbox"/> , H-CIO-A]

Address	Identifier	Description
66	PL	Output change rate limiter (down) [ <input type="checkbox"/> -TIO- <input type="checkbox"/> , H-CIO-A]
67	XE	Direct/Reverse action selection [ <input type="checkbox"/> -TIO- <input type="checkbox"/> , H-CIO-A]
68	XN	Hot/Cold start selection [ <input type="checkbox"/> -TIO- <input type="checkbox"/> , H-CIO-A]
69	SX	Start determination point [ <input type="checkbox"/> -TIO- <input type="checkbox"/> , H-CIO-A]
6A	X1	Control RUN/STOP holding [ <input type="checkbox"/> -PCP-A/B]
6B	EK	Temperature rise completion hold function [ <input type="checkbox"/> -PCP-A/B]
6C	ZX	Transmit interval time setting [ <input type="checkbox"/> -PCP-A/B]
6D	HA	Alarm 1 differential gap [ <input type="checkbox"/> -TIO- <input type="checkbox"/> , H-CIO-A]
6E	HB	Alarm 2 differential gap [ <input type="checkbox"/> -TIO- <input type="checkbox"/> , H-CIO-A]
6F	XA	Alarm 1 type selection [ <input type="checkbox"/> -TIO- <input type="checkbox"/> , H-CIO-A]
70	XB	Alarm 2 type selection [ <input type="checkbox"/> -TIO- <input type="checkbox"/> , H-CIO-A]
71	WA	Alarm 1 hold action [ <input type="checkbox"/> -TIO- <input type="checkbox"/> , H-CIO-A]
72	WB	Alarm 2 hold action [ <input type="checkbox"/> -TIO- <input type="checkbox"/> , H-CIO-A]
73	LA	Alarm 1 interlock [ <input type="checkbox"/> -TIO- <input type="checkbox"/> , H-CIO-A]
74	LB	Alarm 2 interlock [ <input type="checkbox"/> -TIO- <input type="checkbox"/> , H-CIO-A]
75	OA	Alarm 1 action at input error [ <input type="checkbox"/> -TIO- <input type="checkbox"/> , H-CIO-A]
76	OB	Alarm 2 action at input error [ <input type="checkbox"/> -TIO- <input type="checkbox"/> , H-CIO-A]
77	DF	Number of alarm delay times [ <input type="checkbox"/> -TIO- <input type="checkbox"/> , H-CIO-A]
78	CL	Module initialization [ <input type="checkbox"/> -PCP-A/B]
79	VP	PCP module DO type selection [ <input type="checkbox"/> -PCP-A/B]
7A	ZF	CT channel setting [ <input type="checkbox"/> -CT-A]
7B	LT	DO function selection [ <input type="checkbox"/> -DO-A/B/D]
7C	XK	DI function selection [ <input type="checkbox"/> -DI-A]
7D	H2	DI using selection [ <input type="checkbox"/> -DI-A]
7E	VK	AI input range number [H-AI-A/B]
7F	JS	AI display scale high [H-AI-A/B]
80	JV	AI display scale low [H-AI-A/B]
81	HC	AI alarm 1 differential gap [H-AI-A/B]
82	HF	AI alarm 2 differential gap [H-AI-A/B]
83	XC	AI alarm 1 type selection [H-AI-A/B]
84	XD	AI alarm 2 type selection [H-AI-A/B]
85	WC	AI alarm 1 hold action [H-AI-A/B]
86	WD	AI alarm 2 hold action [H-AI-A/B]
87	LC	AI alarm 1 interlock [H-AI-A/B]
88	LD	AI alarm 2 interlock [H-AI-A/B]
89	TK	Number of AI alarm delay times [H-AI-A/B]
8A	JU	AI decimal point position [H-AI-A/B]
8B	JT	Power supply frequency selection [H-PCP-A/B]
8C	F2	AI digital filter [H-AI-A/B]
8D	VA	AI moving average [H-AI-A/B]
8E	XV	Display scale high [H-TIO-H/J, H-CIO-A]
8F	XW	Display scale low [H-TIO-H/J, H-CIO-A]
90	XU	Decimal point position [H-TIO-H/J, H-CIO-A]
91	HV	AO display scale high [H-AO-A/B]
92	HW	AO display scale low [H-AO-A/B]
93	JR	AO decimal point position [H-AO-A/B]
94	PW	AO output change rate limiter [H-AO-A/B]
95	XF	Event DO function selection [H-DO-C]
96	XG	Event DO corresponding channel setting [H-DO-C]
97	XH	Event DO mode select setting [H-DO-C]
98	HG	Event DO extension alarm differential gap [H-DO-C]
99	LE	Event DO extension alarm interlock [H-DO-C]

Address	Identifier	Description
9A	TI	Number of Event DO extension alarm delay times [H-DO-C]
9B	XL	Cascade tracking [H-CIO-A]
9C	KD	Cascade data selection [H-CIO-A]
9D	H3	Cascade DI function selection [H-CIO-A]
9E	XJ	TI input range number [H-TI-A/B/C]
9F	F3	TI digital filter [H-TI-A/B/C]
A0	HI	TI alarm 1 differential gap [H-TI-A/B/C]
A1	HJ	TI alarm 2 differential gap [H-TI-A/B/C]
A2	XP	TI alarm 1 type selection [H-TI-A/B/C]
A3	XQ	TI alarm 2 type selection [H-TI-A/B/C]
A4	WE	TI alarm 1 hold action [H-TI-A/B/C]
A5	WF	TI alarm 2 hold action [H-TI-A/B/C]
A6	LF	TI alarm 1 interlock [H-TI-A/B/C]
A7	LG	TI alarm 2 interlock [H-TI-A/B/C]
A8	OC	TI alarm 1 action at input error [H-TI-A/B/C]
A9	OD	TI alarm 2 action at input error [H-TI-A/B/C]
AA	DG	Number of TI alarm delay times [H-TI-A/B/C]
AB	R1	Event DI type selection 1 [H-DI-B]
AC	R2	Event DI type selection 2 [H-DI-B]
AD	R3	Event DI type selection 3 [H-DI-B]
AE	R4	Event DI type selection 4 [H-DI-B]
AF	E1	Event DI corresponding channel selection 1 [H-DI-B]
B0	E2	Event DI corresponding channel selection 2 [H-DI-B]
B1	E3	Event DI corresponding channel selection 3 [H-DI-B]
B2	E4	Event DI corresponding channel selection 4 [H-DI-B]
B3	W1	Event DI reversal selection 1 [H-DI-B]
B4	W2	Event DI reversal selection 2 [H-DI-B]
B5	W3	Event DI reversal selection 3 [H-DI-B]
B6	W4	Event DI reversal selection 4 [H-DI-B]
B7	LU	Event DI logic circuit selection [H-DI-B]
B8	LW	Event DI delay timer setting [H-DI-B]
B9	DH	Number of HBA trigger points [H-CT-A]
BA	FV	Positioning adjustment counter [H-TIO-K]
BB	VQ	PCP module DI type selection [H-PCP-B]
BC	H4	PCP module DI use selection [H-PCP-B]
BD	VS	PCP module DO de-energized selection [H-PCP-A, M-PCP-A (Z-190)]

**IMPORTANT**

- Setting "Use system data area" to GP-Pro EX system area result in improper operation. Do not set "Use system data area."

**NOTE**

- System area setting that can be used for the temperature controller is reading area size only. Please refer to the GP-Pro EX Reference Manual for system data area.  
Cf. GP-Pro EX Reference Manual "LS Area (Direct Access Method Area)"
- Please refer to the precautions on manual notation for icons in the table.
  - ☞ "Manual Symbols and Terminology"
- Even if non-existing address is used, there are cases when read error is not indicated. In this case, zero (0) is kept for read out data. On the other hand, writing error is indicated.

## 6.9 SR Mini HG(H-PCP-J) Series

 This address can be specified as system data area.

Device	Bit Address	Word Address	32 bits	Notes
Communication identifier	01/0000.0-01/00D4.F	01/0000-01/00D4		*1 *2 *3
	02/0000.0-02/00D4.F	02/0000-02/00D4		
	03/0000.0-03/00D4.F	03/0000-03/00D4		
	04/0000.0-04/00D4.F	04/0000-04/00D4		
	05/0000.0-05/00D4.F	05/0000-05/00D4		
	06/0000.0-06/00D4.F	06/0000-06/00D4		
	07/0000.0-07/00D4.F	07/0000-07/00D4		
	08/0000.0-08/00D4.F	08/0000-08/00D4		
	09/0000.0-09/00D4.F	09/0000-09/00D4		
	10/0000.0-10/00D4.F	10/0000-10/00D4		
	11/0000.0-11/00D4.F	11/0000-11/00D4		
	12/0000.0-12/00D4.F	12/0000-12/00D4		
	13/0000.0-13/00D4.F	13/0000-13/00D4		
	14/0000.0-14/00D4.F	14/0000-14/00D4		
	15/0000.0-15/00D4.F	15/0000-15/00D4		
	16/0000.0-16/00D4.F	16/0000-16/00D4		
	17/0000.0-17/00D4.F	17/0000-17/00D4		
	18/0000.0-18/00D4.F	18/0000-18/00D4		
	19/0000.0-19/00D4.F	19/0000-19/00D4		
	20/0000.0-20/00D4.F	20/0000-20/00D4		
:	:			
95/0000.0-95/00D4.F	95/0000-95/00D4			
96/0000.0-96/00D4.F	96/0000-96/00D4			

\*1 There are cases for which writing is not available depending on the device address. Check the identifying attributes of the external device's manual before use.

\*2 When bit is written, the indicator reads the corresponding word address of external device, assign a bit to the read word address, and return to the external device. There are cases when correct data cannot be written if the word address is written using a ladder program, while the indicator reads data of the external device and sends it back.

\*3 It is necessary to specify the channel number for a module supported by the identifier about SR-Mini-HG (H-PCP-A/B) and SR-Mini-HG (H-PCP-J) Series.

01/0000

└── Channel number (Setting range: 01 to 96)



## &lt;Communication identifier list&gt;

Address	Identifier	Description
00	M1	Temperature measured value (PV) [H-TIO-□, H-CIO-A] / Motor speed measured value [H-SIO-A]
01	AA	Alarm 1 status [H-TIO-□, H-CIO-A, H-SIO-A]
02	AB	Alarm 2 status [H-TIO-□, H-CIO-A, H-SIO-A]
03	B1	Burnout status [H-TIO-□, H-CIO-A, H-SIO-A]
04	O1	Heat-side manipulated output value [H-TIO-□, H-CIO-A]
05	O2	Cool-side manipulated output value [H-TIO-□, H-CIO-A]
06	AC	Heater break alarm status [H-TIO-A/C/D, H-CIO-A]
07	M3	Current transformer input measured value 1 [H-TIO-A/C/D]
08	M4	Current transformer input measured value 2 [H-CT-A]
09	MS	Set value monitor [H-TIO-□, H-CIO-A, H-SIO-A]
0A	HE	Temperature rise completion status [H-TIO-□, H-CIO-A]
0B	ER	Error code [H-PCP-J]
0C	G1	PID/AT transfer [H-TIO-□, H-CIO-A, H-SIO-A]
0D	S1	Temperature set value (SV) [H-TIO-□, H-CIO-A] / Motor speed set value [H-SIO-A]
0E	P1	Heat-side proportional band [H-TIO-□, H-CIO-A, H-SIO-A]
0F	P2	Cool-side proportional band [H-TIO-□, H-CIO-A]
10	I1	Integral time [H-TIO-□, H-CIO-A, H-SIO-A]
11	D1	Derivative time [H-TIO-□, H-CIO-A, H-SIO-A]
12	V1	Overlap/deadband [H-TIO-□, H-CIO-A]
13	CA	Control response parameters [H-TIO-□, H-CIO-A, H-SIO-A]
14	A1	Alarm 1 set value [H-TIO-□, H-CIO-A, H-SIO-A]
15	A2	Alarm 2 set value [H-TIO-□, H-CIO-A, H-SIO-A]
16	A3	Heater break alarm set value 1 [H-TIO-A/C/D]
17	A4	Heater break alarm set value 2 [H-CT-A]
18	EI	Operation mode transfer [H-TIO-□, H-CIO-A, H-SIO-A]
19	T0	Heat-side proportioning cycle time [H-TIO-□, H-CIO-A]
1A	T1	Cool-side proportioning cycle time [H-TIO-□, H-CIO-A]
1B	PB	PV bias [H-TIO-□, H-CIO-A, H-SIO-A]
1C	SR	Control RUN/STOP transfer [H-PCP-J]
1D	IN	Initial setting mode [H-PCP-J]
1E	ZA	Memory area number [H-TIO-□, H-CIO-A, H-SIO-A]
1F	AR	Alarm interlock release [H-TIO-□, H-CIO-A, H-TI-□, H-AI-□]
20	J1	Auto/Manual transfer [H-TIO-□, H-CIO-A]
21	ON	Manual output value [H-TIO-□, H-CIO-A]
22	HD	Temperature rise completion range [H-TIO-□, H-CIO-A]
23	HS	Temperature rise completion trigger [H-TIO-□, H-CIO-A]
24	T3	Temperature rise completion soak time [H-TIO-□, H-CIO-A]
25	M5	AI measured value [H-AI-A/B]
26	AD	AI alarm 1 status [H-AI-A/B]
27	AE	AI alarm 2 status [H-AI-A/B]
28	A5	AI alarm 1 set value [H-AI-A/B]
29	A6	AI alarm 2 set value [H-AI-A/B]
2A	JI	AI zero point correction [H-AI-A/B]
2B	JJ	AI full scale correction [H-AI-A/B]
2C	NJ	AI operation mode transfer [H-AI-A/B]
2D	AP	Control loop break alarm (LBA) status [H-TIO-□, H-CIO-A]
2E	HP	LBA use selection [H-TIO-□, H-CIO-A]
2F	C6	LBA time [H-TIO-□, H-CIO-A]
30	V2	LBA deadband [H-TIO-□, H-CIO-A]
31	M6	AO output value monitor [H-AO-A/B]
32	S6	AO output set value [H-AO-A/B]

Address	Identifier	Description
33	XO	AO function selection [H-AO-A/B]
34	OY	AO corresponding channel setting [H-AO-A/B]
35	CV	AO zooming high limit [H-AO-A/B]
36	CW	AO zooming low limit [H-AO-A/B]
37	JK	AO zero point correction [H-AO-A/B]
38	JL	AO full scale correction [H-AO-A/B]
39	L1	H-DI-A module input status [H-DI-A]
3A	C2	CC-Link selecting flag
3B	Q3	Event DO status [H-DO-C]
3C	Q4	Event DO manual output value [H-DO-C]
3D	A7	Event DO extension alarm set value [H-DO-C]
3E	KH	Cascade monitor [H-CIO-A]
3F	KF	Cascade ON/OFF [H-CIO-A]
40	KG	Cascade gain [H-CIO-A]
41	KI	Cascade bias [H-CIO-A]
42	M7	TI measured value [H-TI-A/B/C]
43	AF	TI alarm 1 status [H-TI-A/B/C]
44	AG	TI alarm 2 status [H-TI-A/B/C]
45	B2	TI burnout status [H-TI-A/B/C]
46	A8	TI alarm 1 set value [H-TI-A/B/C]
47	A9	TI alarm 2 set value [H-TI-A/B/C]
48	PC	TI PV bias [H-TI-A/B/C]
49	EJ	TI operation mode transfer [H-TI-A/B/C]
4A	L3	PCP module DI status
4B	L4	Event DI contact input monitor [H-DI-B]
4C	L5	Event DI logic input monitor [H-DI-B]
4D	Q5	Event DI logic output monitor [H-DI-B]
4E	AH	H-CT-A module heater break alarm status [H-CT-A]
4F	AJ	Comprehensive alarm status [H-PCP-J]
50	M8	Positioning monitor [H-TIO-K]
51	V3	Positioning output neutral zone [H-TIO-K]
52	TJ	Motor time [H-TIO-K]
53	OS	Integrated output limiter [H-TIO-K]
54	OO	Manual positioning output value [H-TIO-K]
55	C1	Local/Computer transfer
56	HH	Setting change rate limiter [H-TIO-□, H-CIO-A, H-SIO-A]
57	D0	H-DO-G manipulated output value [H-DO-G]
58	D2	H-DO-G DO output status [H-DO-G]
59	D3	H-DO-G output limiter (high) [H-DO-G]
5A	D4	H-DO-G output limiter (low) [H-DO-G]
5B	D5	H-DO-G output cycle time [H-DO-G]
5C	D6	H-DO-G Auto/Manual transfer [H-DO-G]
5D	D7	H-DO-G manual output value [H-DO-G]
5E	D8	H-DO-G master channel setting [H-DO-G]
5F	D9	H-DO-G output ratio set value [H-DO-G]
60	ST	PLC scanning time setting [H-PCP-J]
61	GY	Integral time limiter at AT end [H-TIO-□, H-CIO-A, H-SIO-A]
62	XI	Input range number [H-TIO-□, H-CIO-A, H-SIO-A]
63	SH	Setting limiter (high) [H-TIO-□, H-CIO-A, H-SIO-A]
64	SL	Setting limiter (low) [H-TIO-□, H-CIO-A, H-SIO-A]
65	F1	Digital filter [H-TIO-□, H-CIO-A, H-SIO-A]
66	AV	Input error determination point (high) [H-TIO-□, H-CIO-A, H-SIO-A]

Address	Identifier	Description
67	AW	Input error determination point (low) [H-TIO-□, H-CIO-A, H-SIO-A]
68	WH	Action at input error (high) [H-TIO-□, H-CIO-A, H-SIO-A]
69	WL	Action at input error (low) [H-TIO-□, H-CIO-A, H-SIO-A]
6A	GB	AT bias [H-TIO-□, H-CIO-A, H-SIO-A]
6B	OH	Output limiter (high) [For heat/cool control:Heat-side output limiter (high)] [H-TIO-□, H-CIO-A, H-SIO-A]
6C	OL	Output limiter (low) [For heat/cool control:Cool-side output limiter (high)] [H-TIO-□, H-CIO-A, H-SIO-A]
6D	IV	ON/OFF control differential gap (upper) [H-TIO-□, H-CIO-A, H-SIO-A]
6E	IW	ON/OFF control differential gap (lower) [H-TIO-□, H-CIO-A, H-SIO-A]
6F	OE	Manipulated output value at input error [H-TIO-□, H-CIO-A, H-SIO-A]
70	PH	Output change rate limiter (up) [H-TIO-□, H-CIO-A, H-SIO-A]
71	PL	Output change rate limiter (down) [H-TIO-□, H-CIO-A, H-SIO-A]
72	XE	Direct/Reverse action selection [H-TIO-□, H-CIO-A, H-SIO-A]
73	XN	Hot/Cold start selection [H-TIO-□, H-CIO-A, H-SIO-A]
74	SX	Start determination point [H-TIO-□, H-CIO-A]
75	X1	Control RUN/STOP holding [H-PCP-J]
76	EK	Temperature rise completion hold function [H-PCP-J]
77	ZX	Interval time setting COM.PORT1/COM.PORT2 [H-PCP-J]
78	ZY	Interval time setting COM.PORT3 [H-PCP-J]
79	HA	Alarm 1 differential gap [H-TIO-□, H-CIO-A, H-SIO-A]
7A	HB	Alarm 2 differential gap [H-TIO-□, H-CIO-A, H-SIO-A]
7B	XA	Alarm 1 type selection [H-TIO-□, H-CIO-A, H-SIO-A]
7C	XB	Alarm 2 type selection [H-TIO-□, H-CIO-A, H-SIO-A]
7D	WA	Alarm 1 hold action [H-TIO-□, H-CIO-A, H-SIO-A]
7E	WB	Alarm 2 hold action [H-TIO-□, H-CIO-A, H-SIO-A]
7F	LA	Alarm 1 interlock [H-TIO-□, H-CIO-A, H-SIO-A]
80	LB	Alarm 2 interlock [H-TIO-□, H-CIO-A, H-SIO-A]
81	OA	Alarm 1 action at input error [H-TIO-□, H-CIO-A, H-SIO-A]
82	OB	Alarm 2 action at input error [H-TIO-□, H-CIO-A, H-SIO-A]
83	DF	Number of alarm delay times [H-TIO-□, H-CIO-A, H-SIO-A]
84	CL	Module initialization [H-PCP-J]
85	ZF	CT channel setting [H-CT-A]
86	LT	DO function selection [H-DO-A/B/D]
87	XK	DI function selection [H-DI-A]
88	H2	DI using selection [H-DI-A]
89	VK	AI input range number [H-AI-A/B]
8A	JS	AI display scale high [H-AI-A/B]
8B	JV	AI display scale low [H-AI-A/B]
8C	HC	AI alarm 1 differential gap [H-AI-A/B]
8D	HF	AI alarm 2 differential gap [H-AI-A/B]
8E	XC	AI alarm 1 type selection [H-AI-A/B]
8F	XD	AI alarm 2 type selection [H-AI-A/B]
90	WC	AI alarm 1 hold action [H-AI-A/B]
91	WD	AI alarm 2 hold action [H-AI-A/B]
92	LC	AI alarm 1 interlock [H-AI-A/B]
93	LD	AI alarm 2 interlock [H-AI-A/B]
94	TK	Number of AI alarm delay times [H-AI-A/B]
95	JU	AI decimal point position [H-AI-A/B]
96	JT	Power supply frequency selection [H-PCP-J]
97	F2	AI digital filter [H-AI-A/B]
98	VA	AI moving average [H-AI-A/B]
99	XV	Display scale high [H-TIO-H/J,H-CIO-A,H-SIO-A]

Address	Identifier	Description
9A	XW	Display scale low [H-TIO-H/J,H-CIO-A,H-SIO-A]
9B	XU	Decimal point position [H-TIO-H/J,H-CIO-A,H-SIO-A]
9C	HV	AO display scale high [H-AO-A/B]
9D	HW	AO display scale low [H-AO-A/B]
9E	JR	AO decimal point position [H-AO-A/B]
9F	PW	AO output change rate limiter [H-AO-A/B]
A0	XF	Event DO function selection [H-DO-C]
A1	XG	Event DO corresponding channel setting [H-DO-C]
A2	XH	Event DO mode select setting [H-DO-C]
A3	HG	Event DO extension alarm differential gap [H-DO-C]
A4	LE	Event DO extension alarm interlock [H-DO-C]
A5	TI	Number of Event DO extension alarm delay times [H-DO-C]
A6	XL	Cascade tracking [H-CIO-A]
A7	KD	Cascade data selection [H-CIO-A]
A8	H3	Cascade DI function selection [H-CIO-A] / DI process selection [H-SIO-A]
A9	XJ	TI input range number [H-TI-A/B/C]
AA	F3	TI digital filter [H-TI-A/B/C]
AB	HI	TI alarm 1 differential gap [H-TI-A/B/C]
AC	HJ	TI alarm 2 differential gap [H-TI-A/B/C]
AD	XP	TI alarm 1 type selection [H-TI-A/B/C]
AE	XQ	TI alarm 2 type selection [H-TI-A/B/C]
AF	WE	TI alarm 1 hold action [H-TI-A/B/C]
B0	WF	TI alarm 2 hold action [H-TI-A/B/C]
B1	LF	TI alarm 1 interlock [H-TI-A/B/C]
B2	LG	TI alarm 2 interlock [H-TI-A/B/C]
B3	OC	TI alarm 1 action at input error [H-TI-A/B/C]
B4	OD	TI alarm 2 action at input error [H-TI-A/B/C]
B5	DG	Number of TI alarm delay times [H-TI-A/B/C]
B6	R1	Event DI type selection 1 [H-DI-B]
B7	R2	Event DI type selection 2 [H-DI-B]
B8	R3	Event DI type selection 3 [H-DI-B]
B9	R4	Event DI type selection 4 [H-DI-B]
BA	E1	Event DI corresponding channel selection 1 [H-DI-B]
BB	E2	Event DI corresponding channel selection 2 [H-DI-B]
BC	E3	Event DI corresponding channel selection 3 [H-DI-B]
BD	E4	Event DI corresponding channel selection 4 [H-DI-B]
BE	W1	Event DI reversal selection 1 [H-DI-B]
BF	W2	Event DI reversal selection 2 [H-DI-B]
C0	W3	Event DI reversal selection 3 [H-DI-B]
C1	W4	Event DI reversal selection 4 [H-DI-B]
C2	LU	Event DI logic circuit selection [H-DI-B]
C3	LW	Event DI delay timer setting [H-DI-B]
C4	DH	Number of HBA trigger points [H-CT-A]
C5	FV	Positioning adjustment counter [H-TIO-K]
C6	VS	H-PCP-J module DO de-energized selection [H-PCP-J]
C7	JF	H-SIO-A input frequency at full scale [H-SIO-A]
C8	SC	H-SIO-A control range [H-SIO-A]
C9	SU	H-SIO-A output scale high [H-SIO-A]
CA	SD	H-SIO-A output scale low [H-SIO-A]
CB	SP	H-SIO-A measuring method [H-SIO-A]
CC	SQ	H-SIO-A divide ratio [H-SIO-A]
CD	RT	H-SIO-A gate time [H-SIO-A]

Address	Identifier	Description
CE	SA	H-SIO-A auto zero time [H-SIO-A]
CF	SW	H-SIO-A alarm hold cancel time [H-SIO-A]
D0	SM	H-SIO-A open/closed loop control transfer [H-SIO-A]
D1	SE	H-SIO-A correction trigger [H-SIO-A]
D2	J2	H-SIO-A correction actual measured value [H-SIO-A]
D3	JW	PV bias unit selection [H-TIO-H/J,H-CIO-A,H-SIO-A]
D4	VU	H-PCP-J module DO type selection [H-PCP-J]

**IMPORTANT**

- Setting "Use system data area" to GP-Pro EX system area result in improper operation. Do not set "Use system data area."

**NOTE**

- System area setting that can be used for the temperature controller is reading area size only. Please refer to the GP-Pro EX Reference Manual for system data area.

Cf. GP-Pro EX Reference Manual "LS Area (Direct Access Method Area)"

- Please refer to the precautions on manual notation for icons in the table.

 "Manual Symbols and Terminology"

- Even if non-existing address is used, there are cases when read error is not indicated. In this case, zero (0) is kept for read out data. On the other hand, writing error is indicated.

## 6.10 REX-F9000 Series

 This address can be specified as system data area.

Device	Bit Address	Word Address	32 bits	Notes
Communication identifier	0000.00-002F.1F	0000-002F	<input type="checkbox"/> L / <input type="checkbox"/> H	*1 *2 *3

- \*1 There are cases for which writing is not available depending on the device address. Check the identifying attributes of the external device's manual before use.
- \*2 When bit is written, the indicator reads the corresponding word address of external device, assign a bit to the read word address, and return to the external device. There are cases when correct data cannot be written if the word address is written using a ladder program, while the indicator reads data of the external device and sends it back.
- \*3 32-bit device

## &lt;Communication identifier list&gt;

Address	Identifier	Description
00	M1	Measured-value(PV)
01	AA	First alarm output
02	AB	Second alarm output
03	O1	Manipulated output value(MV)
04	B1	Burnout
05	ER	Error code
06	G1	PID/AT transferPID control/auto-tuning transfer
07	J1	Auto/Manual transfer
08	SR	Operation execution (RUN)/STOP transfer
09	S1	Set value (SV)
0A	A1	First alarm setting
0B	A2	Second alarm setting
0C	P1	Proportional band
0D	I1	Integral time
0E	D1	Derivative time
0F	CA	Control response designation parameter
10	PB	PV bias
11	PC	Sensor bias
12	F1	digital filter
13	OH	Output limit (High limit)
14	OL	Output limit (Low limit)
15	GB	AT bias
16	HA	First alarm differential gap
17	TD	First alarm timer setting
18	HB	Second alarm differential gap
19	TG	Second alarm timer setting
1A	LA	Analog output Specification selection
1B	HV	Analog output Scale high limit
1C	HW	Analog output Scale low limit
1D	DA	Bar-graph display selection
1E	XI	Input type selection
1F	XU	Decimal-point position selection
20	JT	Power supply frequency
21	SH	Setting limit (High limit)

Address	Identifier	Description
22	SL	Setting limit (Low limit)
23	T0	Proportioning cycle(OUT1)
24	XE	Direct/reverse action selection
25	PF	Power feed forward
26	XA	Alarm 1 type selection
27	NA	First alarm Energized/de-energized selection
28	OA	First alarm Action selection at input abnormality
29	WA	First alarm Hold action selection
2A	XB	Alarm 2 type selection
2B	NB	Second alarm Energized/de-energized selection
2C	OB	Second alarm Action selection at input abnormality
2D	WB	Second alarm Hold action selection
2E	LK	Set data lock level
2F	LM	Mode lock level selection

**IMPORTANT**

- Setting "Use system data area" to GP-Pro EX system area result in improper operation. Do not set "Use system data area."

**NOTE**

- System area setting that can be used for the temperature controller is reading area size only. Please refer to the GP-Pro EX Reference Manual for system data area.  
Cf. GP-Pro EX Reference Manual "LS Area (Direct Access Method Area)"
- Please refer to the precautions on manual notation for icons in the table.  
 "Manual Symbols and Terminology"
- Even if non-existing address is used, there are cases when read error is not indicated. In this case, zero (0) is kept for read out data. On the other hand, writing error is indicated.

## 6.11 REX-F Series

 This address can be specified as system data area.

Device	Bit Address	Word Address	32 bits	Notes
Communication identifier	0000.0-0055.F	0000-0055		*1 *2

- \*1 There are cases for which writing is not available depending on the device address. Check the identifying attributes of the external device's manual before use.
- \*2 When bit is written, the indicator reads the corresponding word address of external device, assign a bit to the read word address, and return to the external device. There are cases when correct data cannot be written if the word address is written using a ladder program, while the indicator reads data of the external device and sends it back.

## &lt;Communication identifier list&gt;

Address	Identifier	Description
00	M1	Measured-value (PV) input
01	AA	First alarm output
02	AB	Second alarm output
03	AC	Heater break alarm output
04	O1	Manipulated output (Heating-side)
05	O2	Manipulated output (Cooling-side)
06	B1	Burnout
07	B2	Feedback resistance (FBR) input burnout
08	S2	Remote setting value (RS)
09	M2	Feedback resistance input value (POS)
0A	M3	Current transformer input value
0B	MS	Set-value (SV) monitoring
0C	J1	Auto/manual transfer
0D	C1	Local/remote transfer
0E	E1	Local/external memory area transfer
0F	ZA	Control area No. transfer
10	G1	PID control/auto-tuning transfer
11	RA	Local mode/computer mode identification
12	SR	Operation execution (RUN)/STOP transfer
13	ON	Manipulated output value (MV)
14	S1	Set-value (SV)
15	A1	First alarm setting
16	A2	Second alarm setting
17	P1	Proportional band (Heating-side)
18	I1	Integral time
19	D1	Derivative time
1A	CA	Control response designation parameter
1B	P2	Cooling-side proportional band
1C	V1	Deadband
1D	HH	Setting change rate limit
1E	PB	PV bias
1F	F1	PV digital filter
20	DP	PV low input cut-off
21	RR	RS ratio
22	RB	RS bias



Address	Identifier	Description
23	F2	RS digital filter
24	OH	Output limit (High limit)
25	OL	Output limit (Low limit)
26	OQ	Cooling output Min. ON time
27	PH	Increase in output change rate limit
28	PL	Decrease in output change rate limit
29	IV	Upper ON/OFF action (A) differential gap
2A	IW	Lower ON/OFF action (A) differential gap
2B	OE	Manual output at abnormality
2C	GB	AT bias
2D	HA	First alarm differential gap
2E	TD	First alarm timer setting
2F	A3	Heater break alarm
30	HB	Second alarm differential gap
31	TG	Second alarm timer setting
32	LA	Analog output (AO) Specification selection
33	HV	Analog output (AO) Scale high limit
34	HW	Analog output (AO) Scale low limit
35	V2	Neutral zone
36	VH	Open/close output differential gap
37	SY	Action selection at feedback resistance (FBR) input break
38	DA	Bar-graph display selection
39	XI	PV input type selection
3A	AV	Input abnormality determination point (High limit)
3B	AW	Input abnormality determination point (Low limit)
3C	WH	Action selection at input abnormality (High limit)
3D	WL	Action selection at input abnormality (Low limit)
3E	XV	Input programmable range (High limit)
3F	XW	Input programmable range (Low limit)
40	XU	Decimal-point position selection
41	XH	Square root extraction selection
42	SH	Setting limit (High limit)
43	SL	Setting limit (Low limit)
44	XR	RS input type selection
45	XL	SV tracking selection
46	T0	Proportioning cycle (Heating-side)
47	T1	Cooling-side proportioning cycle
48	XE	Direct/reverse action selection
49	XN	Hot/cold start selection
4A	SX	Start determination point
4B	XA	First alarm Action selection
4C	NA	First alarm Energized/de-energized selection
4D	OA	First alarm Action selection at input abnormality
4E	WA	First alarm Hold action selection
4F	XB	Second alarm Action selection
50	NB	Second alarm Energized/de-energized selection
51	OB	Second alarm Action selection at input abnormality
52	WB	Second alarm Hold action selection
53	LK	Set data lock level
54	LL	area lock
55	DH	Operation RUN/STOP display lock

**IMPORTANT**

- Setting "Use system data area" to GP-Pro EX system area result in improper operation. Do not set "Use system data area."

**NOTE**

- System area setting that can be used for the temperature controller is reading area size only. Please refer to the GP-Pro EX Reference Manual for system data area.  
Cf. GP-Pro EX Reference Manual "LS Area (Direct Access Method Area)"
- Please refer to the precautions on manual notation for icons in the table.
  - ☞ "Manual Symbols and Terminology"
- Even if non-existing address is used, there are cases when read error is not indicated. In this case, zero (0) is kept for read out data. On the other hand, writing error is indicated.

## 6.12 REX-D Series

 This address can be specified as system data area.

Device	Bit Address	Word Address	32 bits	Notes
Communication identifier	0000.0-003E.F	0000-003E	L/H	*1 *2

- \*1 There are cases for which writing is not available depending on the device address. Check the identifying attributes of the external device's manual before use.
- \*2 When bit is written, the indicator reads the corresponding word address of external device, assign a bit to the read word address, and return to the external device. There are cases when correct data cannot be written if the word address is written using a ladder program, while the indicator reads data of the external device and sends it back.

## &lt;Communication identifier list&gt;

Address	Identifier	Description
00	M1	Measured-value(PV)
01	M2	First current transformer input value(CT1)
02	M3	Second current transformer input value(CT2)
03	AA	First alarm output
04	AB	Second alarm output
05	AC	Heater break alarm output 1
06	AD	Heater break alarm output 2
07	AE	Control loop break alarm
08	B1	Burnout
09	O1	Manipulated output 1(Heating-side)
0A	O2	Manipulated output 2(Cooling-side)
0B	MS	Set-value(SV)monitoring
0C	ER	Error data
0D	J1	AUTO/MAN transfer
0E	SR	RUN/STOP transfer
0F	G1	PID/Auto-tuning transfer
10	S1	Set-value(SV1)
11	ON	Manipulated output value(MV)
12	S2	Step set-value(SV2)
13	A1	First alarm setting
14	A2	Second alarm setting
15	A3	First heater break alarm setting
16	A4	Second heater break alarm setting
17	PB	PV bias
18	HH	SV change rate limit
19	XA	First alarm action selection
1A	HA	First alarm differential gap
1B	TD	First alarm timer setting
1C	A5	Control loop break alarm setting
1D	V3	LBA deadband
1E	XB	Second alarm action selection
1F	HB	Second alarm differential gap setting
20	TG	Second alarm timer setting
21	TH	HBA delay timer
22	P1	Proportional band(Heating-side)

Address	Identifier	Description
23	I1	Integral time
24	D1	Derivative time
25	W1	Anti-reset windup(ARW)
26	P2	Cooling-side proportional band
27	V1	Overlap/deadband
28	MH	ON/OFF action differential gap
29	MR	Manual reset
2A	XP	Fazzy
2B	T0	Proportioning cycle(OUT1)
2C	OH	Output limit(High-limit)
2D	OL	Output limit(Low-limit)
2E	XE	Direct/reverse action selection
2F	T1	Proportioning cycle(OUT2)
30	OI	Output limit(high-limit)(OUT2)
31	LA	Analog output specification selection
32	HV	High limit analog output range
33	HW	Low limit analog output range
34	XI	Input type selection
35	XV	Scaling high-limit
36	XW	Scaling low-limit
37	XU	Decimal-point position selection
38	PQ	AUTO/MAN function selection
39	DH	Control RUN/STOP display selection
3A	XR	Current transformer type selection
3B	XQ	Air cooling/water cooling selection
3C	GH	Auto-tuning(AT)differential gap
3D	WH	Action selection at input abnormality
3E	XO	Universal output selection

**IMPORTANT**

- Setting "Use system data area" to GP-Pro EX system area result in improper operation. Do not set "Use system data area."

**NOTE**

- System area setting that can be used for the temperature controller is reading area size only. Please refer to the GP-Pro EX Reference Manual for system data area.  
Cf. GP-Pro EX Reference Manual "LS Area (Direct Access Method Area)"
- Please refer to the precautions on manual notation for icons in the table.  
☞ "Manual Symbols and Terminology"
- Even if non-existing address is used, there are cases when read error is not indicated. In this case, zero (0) is kept for read out data. On the other hand, writing error is indicated.

## 6.13 REX-G9 Series

 This address can be specified as system data area.

Device	Bit Address	Word Address	32 bits	Notes
Communication identifier	0000.00-005E.1F	0000-005E	L/H	*1 *2 *3

- \*1 There are cases for which writing is not available depending on the device address. Check the identifying attributes of the external device's manual before use.
- \*2 When bit is written, the indicator reads the corresponding word address of external device, assign a bit to the read word address, and return to the external device. There are cases when correct data cannot be written if the word address is written using a ladder program, while the indicator reads data of the external device and sends it back.
- \*3 32-bit device

## &lt;Communication identifier list&gt;

Address	Identifier	Description
00	M1	Measured-value (PV) input
01	AA	First alarm output
02	AB	Second alarm output
03	AC	Third alarm output
04	O1	Manipulated output1
05	B1	Burnout
06	B2	Feedback resistance (FBR) input burnout
07	S2	Remote setting value
08	M2	Feedback display
09	MS	Set-value (SV) monitoring
0A	J1	Auto/Manual transfer
0B	C1	Remote/Local transfer
0C	E1	Local/external memory area transfer
0D	ZA	Control area No. transfer
0E	G1	PID control/auto-tuning transfer
0F	RA	Computer mode/local mode identification
10	SR	Operation execution (RUN)/STOP transfer
11	ON	Manipulated output value
12	S1	Set-value (SV)
13	A1	First alarm setting
14	A2	Second alarm setting
15	A3	Third alarm setting
16	P1	Proportional band
17	I1	Integral time
18	D1	Derivative time
19	CA	Control response designation parameter
1A	PB	PV bias
1B	F1	PV digital filter
1C	VA	PV Moving average
1D	DP	PV low input cut-off
1E	HH	Setting change rate limiter (up)
1F	HL	Setting change rate limiter (down)
20	RR	RS ratio
21	RB	RS bias

Address	Identifier	Description
22	F2	RS digital filter
23	VB	RS Moving average
24	OH	Output limit (High limit)
25	OL	Output limit (Low limit)
26	PH	Increase in output change rate limit
27	PL	Decrease in output change rate limit
28	IV	Upper ON/OFF action (A) differential gap
29	IW	Lower ON/OFF action (A) differential gap
2A	DG	Derivative gain
2B	OE	Manual output at abnormality
2C	GB	AT bias
2D	G2	AT cycles
2E	HA	Alarm 1 hysteresis
2F	HB	Alarm 2 hysteresis
30	HC	Alarm 3 hysteresis
31	LA	Analog output 1 Specification selection
32	HV	Analog output 1 Scale high limit
33	HW	Analog output 1 Scale low limit
34	LB	Analog output 2 Specification selection
35	CV	Analog output 2 Scale high limit
36	CW	Analog output 2 Scale low limit
37	V2	Neutral zone
38	VH	Open/close hysteresis
39	SY	Action selection at feedback resistance (FBR) input break
3A	TL	Display update cycle
3B	DA	Deflection bar graph(display/non-display)
3C	DB	RS bar graph(display/non-display)
3D	DC	PV bar graph(display/non-display)
3E	DE	Range of display in deflection bar graph
3F	XI	PV input type selection
40	AV	Input abnormality determination point (High limit)
41	AW	Input abnormality determination point (Low limit)
42	WH	Action selection at input abnormality (High limit)
43	WL	Action selection at input abnormality (Low limit)
44	XV	Input programmable range (High limit)
45	XW	Input programmable range (Low limit)
46	PU	PV input unit
47	XU	Decimal-point position selection
48	XH	Square root extraction selection
49	SH	Setting limit (High limit)
4A	SL	Setting limit (Low limit)
4B	XR	RS input type selection
4C	XL	SV tracking selection
4D	T0	Output cycles
4E	XE	Direct/reverse action selection
4F	DT	Derivative cycle
50	XN	Hot/Cold start selection
51	XA	First alarm Action selection
52	NA	First alarm Energized/de-energized selection
53	OA	First alarm Action selection at input abnormality
54	WA	First alarm Hold action selection
55	XB	Second alarm Action selection

Address	Identifier	Description
56	NB	Second alarm Energized/de-energized selection
57	OB	Second alarm Action selection at input abnormality
58	WB	Second alarm Hold action selection
59	XC	Third alarm Action selection
5A	NC	Third alarm Energized/de-energized selection
5B	OC	Third alarm Action selection at input abnormality
5C	WC	Third alarm Hold action selection
5D	JT	Power supply frequency
5E	LK	Setting lock No.

**IMPORTANT**

- Setting "Use system data area" to GP-Pro EX system area result in improper operation. Do not set "Use system data area."

**NOTE**

- System area setting that can be used for the temperature controller is reading area size only. Please refer to the GP-Pro EX Reference Manual for system data area.  
Cf. GP-Pro EX Reference Manual "LS Area (Direct Access Method Area)"
- Please refer to the precautions on manual notation for icons in the table.  
☞ "Manual Symbols and Terminology"
- Even if non-existing address is used, there are cases when read error is not indicated. In this case, zero (0) is kept for read out data. On the other hand, writing error is indicated.

## 6.14 REX-P300 Series

 This address can be specified as system data area.

Device	Bit Address	Word Address	32 bits	Notes
Communication identifier	0000.00-001F.1F 002D.00-0078.1F	0000-001F 002D-0078	<b>L/H</b>	*1 *2 *3

- \*1 There are cases for which writing is not available depending on the device address. Check the identifying attributes of the external device's manual before use.
- \*2 When bit is written, the indicator reads the corresponding word address of external device, assign a bit to the read word address, and return to the external device. There are cases when correct data cannot be written if the word address is written using a ladder program, while the indicator reads data of the external device and sends it back.
- \*3 32-bit device

## &lt;Communication identifier list&gt;

Address	Identifier	Description
00	M1	Measured value(PV)monitoring
01	S1	Set value(SV)monitoring
02	O1	Manipulated output monitoring 1 (Heat side)
03	O2	Manipulated output monitoring 2 (Cool side)
04	AA	First alarm monitoring
05	AB	Second alarm monitoring
06	B1	Burnout
07	PS	Pattern No.
08	SN	Segment No.
09	T1	Time signal output No.1 status
0A	T2	Time signal output No.2 status
0B	T3	Time signal output No.3 status
0C	T4	Time signal output No.4 status
0D	T5	Time signal output No.5 status
0E	T6	Time signal output No.6 status
0F	T7	Time signal output No.7 status
10	T8	Time signal output No.8 status
11	EO	Program end output
12	AC	OUT2 action output
13	AD	OUT3 action output
14	AE	OUT4 action output
15	ER	Error
16	TR	Segment remaining time
17	RT	No. of repeat execution times
18	ON	Manipulated output value(MV)
19	G1	PID/AT transfer
1A	XM	Operation mode
1B	EN	Program end status
1C	WT	Wait status
1D	HO	Hold status
1E	SK	Step function
1F	SM	Search function
20	-	-
21	-	-



Address	Identifier	Description
22	-	-
23	-	-
24	-	-
25	-	-
26	-	-
27	-	-
28	-	-
29	-	-
2A	-	-
2B	-	-
2C	-	-
2D	S2	FIX set value
2E	PB	PV bias
2F	PR	PV ratio
30	PW	Level PID setting1
31	PX	Level PID setting2
32	PY	Level PID setting3
33	F1	Digital filter
34	DP	Low level cut-off point
35	A1	First alarm setting
36	A2	Second alarm setting
37	XA	First alarm action selection
38	XB	Second alarm action selection
39	HA	First alarm differential gap
3A	HB	Second alarm differential gap
3B	TD	First alarm timer
3C	TG	Second alarm timer
3D	NA	First alarm energized/de-energized selection
3E	NB	Second alarm energized/de-energized selection
3F	P1	Proportional band 1
40	P3	Proportional band 2
41	P5	Proportional band 3
42	P7	Proportional band 4
43	I1	Integral time 1
44	I2	Integral time 2
45	I3	Integral time 3
46	I4	Integral time 4
47	D1	Derivative time 1
48	D2	Derivative time 2
49	D3	Derivative time 3
4A	D4	Derivative time 4
4B	W1	Anti-reset windup 1(ARW)
4C	W2	Anti-reset windup 2(ARW)
4D	W3	Anti-reset windup 3(ARW)
4E	W4	Anti-reset windup 4(ARW)
4F	P2	Cool side proportional band 1
50	P4	Cool side proportional band 2
51	P6	Cool side proportional band 3
52	P8	Cool side proportional band 4
53	V1	Deadband/Overlap 1 / Control motor neutral zone 1
54	V2	Deadband/Overlap 2 / Control motor neutral zone 2
55	V3	Deadband/Overlap 3 / Control motor neutral zone 3

Address	Identifier	Description
56	V4	Deadband/Overlap 4 / Control motor neutral zone 4
57	XP	Fuzzy function 1
58	FW	Fuzzy function 2
59	FX	Fuzzy function 3
5A	FY	Fuzzy function 4
5B	TC	Output cycle 1 / Control motor time
5C	T0	Output cycle 2
5D	OH	Output limit(High limit) / Integrated output limit
5E	OL	Output limit(Low limit)
5F	XE	Direct/reverse action selection
60	KB	OUT2 action selection
61	A3	OUT2 set value
62	XC	OUT3 action selection
63	A4	OUT3 set value
64	XD	OUT4 action selection
65	A5	OUT4 set value
66	LA	Analog output selection
67	HV	Analog output scaling high limit
68	HW	Analog output scaling low limit
69	XI	Input type selection
6A	XV	Scale high limit
6B	XW	Scale low limit
6C	XU	Decimal point position
6D	SS	SV at program start
6E	X1	Control state at program end
6F	XN	Control output value during reset / Control state selection during reset
70	XK	Control input pattern entry method
71	XQ	Water cooling/air cooling selection at heat/cool control
72	PD	Start mode selection
73	GH	Autotuning(AT) differential gap
74	JT	Power frequency
75	B2	Action selection at burnout occurrence
76	WH	Action selection for abnormal PV input
77	XH	Selection of Use/Non-use of square root extraction function
78	PU	Setting time unit selection

**IMPORTANT**

- Setting "Use system data area" to GP-Pro EX system area result in improper operation. Do not set "Use system data area."

**NOTE**

- System area setting that can be used for the temperature controller is reading area size only. Please refer to the GP-Pro EX Reference Manual for system data area.  
Cf. GP-Pro EX Reference Manual "LS Area (Direct Access Method Area)"
- Please refer to the precautions on manual notation for icons in the table.  
☞ "Manual Symbols and Terminology"
- Even if non-existing address is used, there are cases when read error is not indicated. In this case, zero (0) is kept for read out data. On the other hand, writing error is indicated.

## 6.15 REX-P250 Series

 This address can be specified as system data area.

Device	Bit Address	Word Address	32 bits	Notes
Communication identifier	0000.0-0027.F	0000-0027		*1 *2

\*1 There are cases for which writing is not available depending on the device address. Check the identifying attributes of the external device's manual before use.

\*2 When bit is written, the indicator reads the corresponding word address of external device, assign a bit to the read word address, and return to the external device. There are cases when correct data cannot be written if the word address is written using a ladder program, while the indicator reads data of the external device and sends it back.

## &lt;Communication identifier list&gt;

Address	Identifier	Description
00	M1	Measured-value(PV)
01	S1	Set-value(SV)during operation
02	ON	Manipulated-value(MV)or Manual control output set-value
03	TR	Segment remaining time
04	RT	The number of program execution times
05	M2	Opening feedback input value or Current transformer input value
06	AA	Alarm 1 output
07	AB	Alarm 2 output
08	B1	Burnout
09	HO	Hold status
0A	EN	End status
0B	WT	Wait status
0C	T1	Time signal No.1 status
0D	T2	Time signal No.2 status
0E	T3	Time signal No.3 status
0F	T4	Time signal No.4 status
10	XM	Operation mode
11	PS	Execution pattern
12	SN	Execution segment
13	RA	COMP/LOC identification
14	G1	AT/PID identification
15	TT	AT learning function
16	SK	Step function
17	S2	Set-value(SV)
18	PP	PID memory NO.
19	AP	Alarm memory NO.
1A	PQ	PID memory NO.
1B	AQ	Alarm memory NO.
1C	PB	PV bias
1D	HA	Alarm 1 hysteresis band
1E	HB	Alarm 2 hysteresis band
1F	TC	Proportional cycle setting
20	F1	Digital filter
21	XN	Start mode selection
22	SS	Set-value(SV)selection at start[Program control]

Address	Identifier	Description
23	ER	Error code
24	CL	Data all clear
25	TR	Segment remaining time
26	TR	Segment remaining time
27	TR	Segment remaining time

**IMPORTANT**

- Setting "Use system data area" to GP-Pro EX system area result in improper operation. Do not set "Use system data area."

**NOTE**

- System area setting that can be used for the temperature controller is reading area size only. Please refer to the GP-Pro EX Reference Manual for system data area.  
Cf. GP-Pro EX Reference Manual "LS Area (Direct Access Method Area)"
- Please refer to the precautions on manual notation for icons in the table.
  - ☞ "Manual Symbols and Terminology"
- Even if non-existing address is used, there are cases when read error is not indicated. In this case, zero (0) is kept for read out data. On the other hand, writing error is indicated.

## 6.16 REX-AD Series

 This address can be specified as system data area.

Device	Bit Address	Word Address	32 bits	Notes
Communication identifier	0000.0-003B.F	0000-003B		*1 *2

- \*1 There are cases for which writing is not available depending on the device address. Check the identifying attributes of the external device's manual before use.
- \*2 When bit is written, the indicator reads the corresponding word address of external device, assign a bit to the read word address, and return to the external device. There are cases when correct data cannot be written if the word address is written using a ladder program, while the indicator reads data of the external device and sends it back.

## &lt;Communication identifier list&gt;

Address	Identifier	Description
00	M1	Measured-value(PV)
01	AA	First alarm monitor
02	AB	Second alarm monitor
03	AC	Third alarm monitor
04	AD	Fourth alarm monitor
05	AE	Fifth alarm monitor
06	AF	Sixth alarm monitor
07	AG	EXCEED monitor
08	B1	Burnout
09	ER	Error data
0A	HP	Peak hold monitor
0B	HQ	Bottom hold monitor
0C	TM	Time duration monitor
0D	HR	Hold reset
0E	IR	Interlock release
0F	A1	First alarm setting
10	A2	Second alarm setting
11	A3	Third alarm setting
12	A4	Fourth alarm setting
13	A5	Fifth alarm setting
14	A6	Sixth alarm setting
15	PB	PV bias
16	F1	Digital filter
17	XA	First alarm action selection
18	QA	First alarm interlock
19	NA	First alarm Energized/De-energized
1A	HA	First alarm differential gap
1B	TD	First alarm timer setting selection
1C	XB	Second alarm action selection
1D	QB	Second alarm interlock
1E	NB	Second alarm Energized/De-energized
1F	HB	Second alarm differential gap
20	TG	Second alarm timer setting selection
21	XC	Third alarm action selection
22	QC	Third alarm interlock

Address	Identifier	Description
23	NC	Third alarm Energized/De-energized
24	HC	Third alarm differential gap
25	TH	Third alarm timer setting selection
26	XD	Fourth alarm action selection
27	QD	Fourth alarm interlock
28	ND	Fourth alarm Energized/De-energized
29	HD	Fourth alarm differential gap
2A	TI	Fourth alarm timer setting selection
2B	XE	Fifth alarm action selection
2C	QE	Fifth alarm interlock
2D	NE	Fifth alarm Energized/De-energized
2E	HE	Fifth alarm differential gap
2F	TJ	Fifth alarm timer setting selection
30	XF	Sixth alarm action selection
31	QF	Sixth alarm interlock
32	NF	Sixth alarm Energized/De-energized
33	HF	Sixth alarm differential gap
34	TK	Sixth alarm timer setting selection
35	HV	Analog output high-limit set-value
36	HW	Analog output low-limit set-value
37	XI	Input type selection
38	XV	Scaling high-limit setting
39	XW	Scaling low-limit setting
3A	XU	Decimal point position selection
3B	TS	Time unit selection setting

**IMPORTANT**

- Setting "Use system data area" to GP-Pro EX system area result in improper operation. Do not set "Use system data area."

**NOTE**

- System area setting that can be used for the temperature controller is reading area size only. Please refer to the GP-Pro EX Reference Manual for system data area.  
Cf. GP-Pro EX Reference Manual "LS Area (Direct Access Method Area)"
- Please refer to the precautions on manual notation for icons in the table.  
☞ "Manual Symbols and Terminology"
- Even if non-existing address is used, there are cases when read error is not indicated. In this case, zero (0) is kept for read out data. On the other hand, writing error is indicated.

## 6.17 REX-PG Series

 This address can be specified as system data area.

Device	Bit Address	Word Address	32 bits	Notes
Communication identifier	0000.0-0021.F	0000-0021	L/H	*1 *2

- \*1 There are cases for which writing is not available depending on the device address. Check the identifying attributes of the external device's manual before use.
- \*2 When bit is written, the indicator reads the corresponding word address of external device, assign a bit to the read word address, and return to the external device. There are cases when correct data cannot be written if the word address is written using a ladder program, while the indicator reads data of the external device and sends it back.

## &lt;Communication identifier list&gt;

Address	Identifier	Description
00	M1	Measured-value (PV)
01	AA	Alarm 1 monitor
02	AB	Alarm 2 monitor
03	B1	Burnout
04	ER	Error data
05	HP	Peak hold monitor
06	HQ	Bottom hold monitor
07	AZ	Auto 0
08	HR	Hold reset
09	IR	Alarm interlock release
0A	A1	First alarm setting
0B	A2	Second alarm setting
0C	IB	Operation selection when input break
0D	TL	Display time setting
0E	XA	First alarm Action selection
0F	QA	First alarm interlock function
10	NA	First alarm Energized/de-energized selection
11	HA	First alarm differential gap
12	TD	First alarm timer setting
13	XB	Second alarm Action selection
14	QB	Second alarm interlock function
15	NB	Second alarm Energized/de-energized selection
16	HB	Second alarm differential gap
17	TG	Second alarm timer setting
18	HW	Low limit analog output range
19	HV	High limit analog output range
1A	TO	Analog output time setting
1B	XI	Input type selection
1C	GA	Gain setting
1D	PU	Pressure unit setting
1E	XU	Decimal-point position selection
1F	XW	Pressure display low limit setting
20	XV	Pressure display high limit setting
21	LI	Linearizing type selection

**IMPORTANT**

- Setting "Use system data area" to GP-Pro EX system area result in improper operation. Do not set "Use system data area."

**NOTE**

- System area setting that can be used for the temperature controller is reading area size only. Please refer to the GP-Pro EX Reference Manual for system data area.

Cf. GP-Pro EX Reference Manual "LS Area (Direct Access Method Area)"

- Please refer to the precautions on manual notation for icons in the table.

 "Manual Symbols and Terminology"

- Even if non-existing address is used, there are cases when read error is not indicated. In this case, zero (0) is kept for read out data. On the other hand, writing error is indicated.



## 6.18 AE500 Series

 This address can be specified as system data area.

Device	Bit Address	Word Address	32 bits	Notes
Communication identifier	0000.0-0012.F	0000-0012		*1 *2

- \*1 There are cases for which writing is not available depending on the device address. Check the identifying attributes of the external device's manual before use.
- \*2 When bit is written, the indicator reads the corresponding word address of external device, assign a bit to the read word address, and return to the external device. There are cases when correct data cannot be written if the word address is written using a ladder program, while the indicator reads data of the external device and sends it back.

<Communication identifier list>

Address	Identifier	Description
00	M1	Measured value (PV)
01	AA	Alarm 1 monitor
02	AB	Alarm 2 monitor
03	AC	Alarm 3 monitor
04	AD	Alarm 4 monitor
05	B1	Burnout
06	ER	Error code
07	A1	Alarm 1 setting
08	A2	Alarm 2 setting
09	A3	Alarm 3 setting
0A	A4	Alarm 4 setting
0B	HA	Alarm 1 differential gap setting
0C	HB	Alarm 2 differential gap setting
0D	HC	Alarm 3 differential gap setting
0E	HD	Alarm 4 differential gap setting
0F	PB	PV bias
10	HV	Analog output scale high
11	HW	Analog output scale low
12	LK	Set data lock function

**IMPORTANT**

- Setting "Use system data area" to GP-Pro EX system area result in improper operation. Do not set "Use system data area."

**NOTE**

- System area setting that can be used for the temperature controller is reading area size only. Please refer to the GP-Pro EX Reference Manual for system data area.  
Cf. GP-Pro EX Reference Manual "LS Area (Direct Access Method Area)"
- Please refer to the precautions on manual notation for icons in the table.
  -  "Manual Symbols and Terminology"
- Even if non-existing address is used, there are cases when read error is not indicated. In this case, zero (0) is kept for read out data. On the other hand, writing error is indicated.

## 6.19 LE100 Series

 This address can be specified as system data area.

Device	Bit Address	Word Address	32 bits	Notes
Communication identifier	0000.0-0072.F	0000-0072		*1 *2

- \*1 There are cases for which writing is not available depending on the device address. Check the identifying attributes of the external device's manual before use.
- \*2 When bit is written, the indicator reads the corresponding word address of external device, assign a bit to the read word address, and return to the external device. There are cases when correct data cannot be written if the word address is written using a ladder program, while the indicator reads data of the external device and sends it back.

## &lt;Communication identifier list&gt;

Address	Identifier	Description
00	M1	Measured value (PV)
01	AA	Output 1 status
02	AB	Output 2 status
03	AC	Output 3 status
04	AD	Output 4 status
05	AE	Output 5 status
06	AF	Output 6 status
07	AG	Output 7 status
08	AH	Output 8 status
09	B1	Burnout
0A	ER	Error code
0B	ID	ID data
0C	ID	ID data
0D	ID	ID data
0E	MS	Specific gravity monitor
0F	ML	Scale low monitor
10	MH	Scale high monitor
11	HP	Peak hold monitor
12	HQ	Bottom hold monitor
13	MW	Number of wafer processing times monitor
14	MZ	Amount of emptiness correction monitor
15	A1	Output 1 set value
16	A2	Output 2 set value
17	A3	Output 3 set value
18	A4	Output 4 set value
19	A5	Output 5 set value
1A	A6	Output 6 set value
1B	A7	Output 7 set value
1C	A8	Output 8 set value
1D	A9	Actual liquid output setting
1E	AZ	Emptiness adjustment
1F	WT	Number of wafer processing times
20	CW	Initializing the number of wafer processing times
21	HR	Hold reset
22	IR	Interlock release

Address	Identifier	Description
23	LK	Set data lock
24	IS	Default setting
25	EC	Error release
26	LU	Decimal point position selection
27	LT	Number of linearizing table setting
28	L0	Linearizing table setting 0
29	L1	Linearizing table setting 1
2A	L2	Linearizing table setting 2
2B	L3	Linearizing table setting 3
2C	L4	Linearizing table setting 4
2D	L5	Linearizing table setting 5
2E	L6	Linearizing table setting 6
2F	L7	Linearizing table setting 7
30	L8	Linearizing table setting 8
31	L9	Linearizing table setting 9
32	LA	Linearizing table setting 10
33	F1	Digital filter
34	XA	Output 1 type selection
35	DA	Output 1 deviation value setting
36	QA	Output 1 interlocking function selection
37	NA	Output 1 a/b contact selection
38	HA	Output 1 differential gap
39	TA	Output 1 timer setting
3A	XB	Output 2 type selection
3B	DB	Output 2 deviation value setting
3C	QB	Output 2 interlocking function selection
3D	NB	Output 2 a/b contact selection
3E	HB	Output 2 differential gap
3F	TB	Output 2 timer setting
40	XC	Output 3 type selection
41	DC	Output 3 deviation value setting
42	QC	Output 3 interlocking function selection
43	NC	Output 3 a/b contact selection
44	HC	Output 3 differential gap
45	TC	Output 3 timer setting
46	XD	Output 4 type selection
47	DD	Output 4 deviation value setting
48	QD	Output 4 interlocking function selection
49	ND	Output 4 a/b contact selection
4A	HD	Output 4 differential gap
4B	TD	Output 4 timer setting
4C	XE	Output 5 type selection
4D	DE	Output 5 deviation value setting
4E	QE	Output 5 interlocking function selection
4F	NE	Output 5 a/b contact selection
50	HE	Output 5 differential gap
51	TE	Output 5 timer setting
52	XF	Output 6 type selection
53	DF	Output 6 deviation value setting
54	QF	Output 6 interlocking function selection
55	NF	Output 6 a/b contact selection
56	HF	Output 6 differential gap

Address	Identifier	Description
57	TF	Output 6 timer setting
58	XG	Output 7 type selection
59	DG	Output 7 deviation value setting
5A	QG	Output 7 interlocking function selection
5B	NG	Output 7 a/b contact selection
5C	HG	Output 7 differential gap
5D	TG	Output 7 timer setting
5E	XH	Output 8 type selection
5F	DH	Output 8 deviation value setting
60	QH	Output 8 interlocking function selection
61	NH	Output 8 a/b contact selection
62	HH	Output 8 differential gap
63	TH	Output 8 timer setting
64	HV	Monitor output high
65	HW	Monitor output low
66	EG	End specific gravity setting
67	SW	Number of wafer processing times setting
68	XX	Scale low
69	SG	Specific gravity setting
6A	J1	Scale 1 actual liquid setting
6B	J2	Scale 2 actual liquid setting
6C	J3	Correction on the low limit side by actual liquid 2
6D	J4	Correction on the high limit side by actual liquid 2
6E	UN	Unit setting
6F	SP	Specific gravity setting transfer
70	SS	Specific gravity correction function selection
71	DS	DI function selection
72	MM	Volume/level display selection

**IMPORTANT**

- Setting "Use system data area" to GP-Pro EX system area result in improper operation. Do not set "Use system data area."

**NOTE**

- System area setting that can be used for the temperature controller is reading area size only. Please refer to the GP-Pro EX Reference Manual for system data area.  
Cf. GP-Pro EX Reference Manual "LS Area (Direct Access Method Area)"
- Please refer to the precautions on manual notation for icons in the table.
  -  "Manual Symbols and Terminology"
- Even if non-existing address is used, there are cases when read error is not indicated. In this case, zero (0) is kept for read out data. On the other hand, writing error is indicated.

6.20 SRZ (Z-TIO) Series

 This address can be specified as system data area.

Device	Bit Address	Word Address	32 bits	Notes
Communication identifier	01/0000.00 -01/00CF.1F	01/0000-01/00CF	<b>L/H</b>	*1 *2 *3*4
	02/0000.00 -02/00CF.1F	02/0000-02/00CF		
	03/0000.00 -03/00CF.1F	03/0000-03/00CF		
	04/0000.00 -04/00CF.1F	04/0000-04/00CF		

- \*1 There are cases for which writing is not available depending on the device address. Check the identifying attributes of the external device's manual before use.
- \*2 When bit is written, the indicator reads the corresponding word address of external device, assign a bit to the read word address, and return to the external device. There are cases when correct data cannot be written if the word address is written using a ladder program, while the indicator reads data of the external device and sends it back.
- \*3 Some of the identifiers are for each channel, some are for each module. As for the identifiers which are for each channel, it is necessary to specified the channel number correctly. As for the identifiers which are for each module, the specified channel number is meaningless.

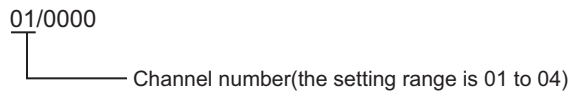

- \*4 32-bit device

## &lt;Communication identifier list&gt;

Address	Identifier	Description	Address	Identifier	Description
00	VR	ROM version	32	A7	Heater break alarm (HBA) set value
01	VR	ROM version	33	NE	Heater break determination point
02	M1	Measured value (PV)	34	NF	Heater melting determination point
03	AJ	Comprehensive event state	35	PB	PV bias
04	L0	Operation mode state monitor	36	F1	PV digital filter
05	ER	Error code	37	PR	PV ratio
06	O1	Manipulated output value (MV) monitor [heat-side]	38	DP	PV low input cut-off
07	O2	Manipulated output value (MV) monitor [cool-side]	39	RB	RS bias
08	M3	Current transformer (CT) input value monitor	3A	F2	RS digital filter
09	MS	Set value (SV) monitor	3B	RR	RS ratio
0A	S2	Remote setting (RS) input value monitor	3C	DV	Output distribution selection
0B	B1	Burnout state monitor	3D	DW	Output distribution bias
0C	AA	Event 1 state monitor	3E	DQ	Output distribution ratio
0D	AB	Event 2 state monitor	3F	T0	Proportional cycle time
0E	AC	Event 3 state monitor	40	VI	Minimum ON/OFF time of proportioning cycle
0F	AD	Event 4 state monitor	41	ON	Manual manipulated output value
10	AE	Heater break alarm (HBA) state monitor	42	RV	Area soak time stop function
11	Q1	Output state monitor	43	NG	EDS mode (for disturbance 1)
12	TR	Memory area soak time monitor	44	NX	EDS mode 2 (for disturbance 2)
13	UT	Integrated operating time monitor	45	NI	EDS value 1 (for disturbance 1)
14	Hp	Holding peak value ambient temperature monitor	46	NJ	EDS value 1 (for disturbance 2)
15	EM	Backup memory state monitor	47	NK	EDS value 2 (for disturbance 1)
16	ED	Logic output monitor 1	48	NM	EDS value 2 (for disturbance 2)
17	EE	Logic output monitor 2	49	NN	EDS transfer time (for disturbance 1)
18	G1	PID/AT transfer	4A	NO	EDS transfer time (for disturbance 2)
19	J1	Auto/Manual transfer	4B	NQ	EDS action time (for disturbance 1)
1A	C1	Remote/Local transfer	4C	NL	EDS action time (for disturbance 2)
1B	SR	RUN/STOP transfer	4D	NR	EDS action wait time (for disturbance 1)
1C	ZA	Memory area transfer	4E	NY	EDS action wait time (for disturbance 2)
1D	AR	Interlock release	4F	NT	EDS value learning times
1E	A1	Event 1 set value (EV1)	50	NU	EDS start signal
1F	A2	Event 2 set value (EV2)	51	EI	Operation mode
20	A3	Event 3 set value (EV3)	52	ST	Startup tuning (ST)
21	A4	Event 4 set value (EV4)	53	Y8	Automatic temperature rise learning
22	A5	Control loop break alarm (LBA) time	54	EF	Communication switch for logic
23	N1	LBA deadband	55	XI	Input type
24	S1	Set value (SV)	56	PU	Display unit
25	P1	Proportional band [heat-side]	57	XU	Decimal point position
26	I1	Integral time [heat-side]	58	XV	Input scale high
27	D1	Derivative time [heat-side]	59	XW	Input scale low
28	CA	Control response parameter	5A	AV	Input error determination point (high)
29	P2	Proportional band [cool-side]	5B	AW	Input error determination point (low)
2A	I2	Integral time [cool-side]	5C	BS	Burnout direction
2B	D2	Derivative time [cool-side]	5D	XH	Square root extraction
2C	V1	Overlap/Deadband	5E	E0	Output assignment (Logic output selection function)
2D	MR	Manual reset	5F	NA	Energized/De-energized (Logic output selection function)
2E	HH	Setting change rate limiter (up)	60	XA	Event 1 type
2F	HL	Setting change rate limiter (down)	61	FA	Event 1 channel setting
30	TM	Area soak time	62	WA	Event 1 hold action
31	LP	Link area number	63	LF	Event 1 interlock

Address	Identifier	Description	Address	Identifier	Description
64	HA	Event 1 differential gap	93	OL	Output limiter (low) [heat-side]
65	TD	Event 1 delay timer	94	PX	Output change rate limiter (up) [cool-side]
66	OA	Force ON of Event 1 action	95	PY	Output change rate limiter (down) [cool-side]
67	XB	Event 2 type	96	OX	Output limiter (high) [cool-side]
68	FB	Event 2 channel setting	97	OY	Output limiter (low) [cool-side]
69	WB	Event 2 hold action	98	GB	AT bias
6A	LG	Event 2 interlock	99	G3	AT cycles
6B	HB	Event 2 differential gap	9A	OP	Output value with AT turned on
6C	TG	Event 2 delay timer	9B	OQ	Output value with AT turned off
6D	OB	Force ON of Event 2 action	9C	GH	AT differential gap time
6E	XC	Event 3 type	9D	KC	Proportional band adjusting factor [heat-side]
6F	FC	Event 3 channel setting	9E	KD	Integral time adjusting factor [heat-side]
70	WC	Event 3 hold action	9F	KE	Derivative time adjusting factor [heat-side]
71	LH	Event 3 interlock	A0	KF	Proportional band adjusting factor [cool-side]
72	HC	Event 3 differential gap	A1	KG	Integral time adjusting factor [cool-side]
73	TE	Event 3 delay timer	A2	KH	Derivative time adjusting factor [cool-side]
74	OC	Force ON of Event 3 action	A3	P6	Proportional band limiter (high) [heat-side]
75	XD	Event 4 type	A4	P7	Proportional band limiter (low) [heat-side]
76	FD	Event 4 channel setting	A5	I6	Integral time limiter (high) [heat-side]
77	WD	Event 4 hold action	A6	I7	Integral time limiter (low) [heat-side]
78	LI	Event 4 interlock	A7	D6	Derivative time limiter (high) [heat-side]
79	HD	Event 4 differential gap	A8	D7	Derivative time limiter (low) [heat-side]
7A	TF	Event 4 delay timer	A9	P8	Proportional band limiter (high) [cool-side]
7B	OD	Force ON of Event 4 action	AA	P9	Proportional band limiter (low) [cool-side]
7C	XS	CT ratio	AB	I8	Integral time limiter (high) [cool-side]
7D	ZF	CT assignment	AC	I9	Integral time limiter (low) [cool-side]
7E	ND	Heater break alarm (HBA) type	AD	D8	Derivative time limiter (high) [cool-side]
7F	DH	Number of heater break alarm (HBA) delay times	AE	D9	Derivative time limiter (low) [cool-side]
80	XN	Hot/Cold start	AF	V2	Open/Close output neutral zone
81	SX	Start determination point	B0	SY	Action at feedback resistance (FBR) input error
82	XL	SV tracking	B1	FV	Feedback adjustment
83	OT	MV transfer function	B2	TN	Control motor time
84	XE	Control action	B3	OI	Integrated output limiter
85	PK	Integral/derivative time decimal point position	B4	VS	Valve action at STOP
86	KA	Derivative action	B5	KI	ST proportional band adjusting factor
87	KB	Undershoot suppression factor	B6	KJ	ST integral time adjusting factor
88	DG	Derivative gain	B7	KK	ST derivative time adjusting factor
89	IV	ON/OFF action differential gap (upper)	B8	SU	ST start condition
8A	IW	ON/OFF action differential gap (lower)	B9	Y7	Automatic temperature rise group
8B	WH	Action (high) at input error	BA	RT	Automatic temperature rise dead time
8C	WL	Action (low) at input error	BB	R2	Automatic temperature rise gradient data
8D	OE	Manipulated output value at input error	BC	NS	EDS transfer time decimal point position
8E	OF	Manipulated output value at STOP mode [heat-side]	BD	NV	Output average processing time for EDS
8F	OG	Manipulated output value at STOP mode [cool-side]	BE	NW	Responsive action trigger point for EDS
90	PH	Output change rate limiter (up) [heat-side]	BF	HU	Setting change rate limiter unit time
91	PL	Output change rate limiter (down) [heat-side]	C0	RU	Soak time unit
92	OH	Output limiter (high) [heat-side]	C1	SH	Setting limiter (high)

Address	Identifier	Description	Address	Identifier	Description
C2	SL	Setting limiter (low)	C9	DY	Output distribution master channel module address
C3	TS	PV transfer function	CA	DZ	Output distribution master channel selection
C4	EA	Operation mode assignment 1 (Logic output selection function) Logic output 1 to 4	CB	RL	Address of interacting modules
C5	EB	Operation mode assignment 2 (Logic output selection function) Logic output 5 to 8	CC	RM	Channel selection of interacting modules
C6	KM	SV select function	CD	RN	Selection switch of interacting modules
C7	MC	Remote SV function master channel module address	CE	X1	Control RUN/STOP holding setting
C8	MN	Remote SV function master channel selection	CF	ZX	Interval time

**IMPORTANT**

- Setting "Use system data area" to GP-Pro EX system area result in improper operation. Do not set "Use system data area."

**NOTE**

- System area setting that can be used for the temperature controller is reading area size only. Please refer to the GP-Pro EX Reference Manual for system data area.  
Cf. GP-Pro EX Reference Manual "LS Area (Direct Access Method Area)"
- Please refer to the precautions on manual notation for icons in the table.  
 "Manual Symbols and Terminology"
- Even if non-existing address is used, there are cases when read error is not indicated. In this case, zero (0) is kept for read out data. On the other hand, writing error is indicated.



## 6.21 SRZ (Z-DIO) Series

 This address can be specified as system data area.

Device	Bit Address	Word Address	32 bits	Notes
Communication identifier	01/0000.00 -01/001E.1F	01/0000-01/001E	<b>L/H</b>	*1 *2 *3*4
	02/0000.00 -02/001E.1F	02/0000-02/001E		
	03/0000.00 -03/001E.1F	03/0000-03/001E		
	04/0000.00 -04/001E.1F	04/0000-04/001E		
	05/0000.00 -05/001E.1F	05/0000-05/001E		
	06/0000.00 -06/001E.1F	06/0000-06/001E		
	07/0000.00 -07/001E.1F	07/0000-07/001E		
	08/0000.00 -08/001E.1F	08/0000-08/001E		

- \*1 There are cases for which writing is not available depending on the device address. Check the identifying attributes of the external device's manual before use.
- \*2 When bit is written, the indicator reads the corresponding word address of external device, assign a bit to the read word address, and return to the external device. There are cases when correct data cannot be written if the word address is written using a ladder program, while the indicator reads data of the external device and sends it back.
- \*3 Some of the identifiers are for each channel, some are for each module. As for the identifiers which are for each channel, it is necessary to specified the channel number correctly. As for the identifiers which are for each module, the specified channel number is meaningless.

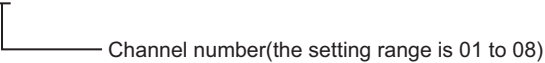
01/0000  

 Channel number(the setting range is 01 to 08)

- \*4 32-bit device

## &lt;Communication identifier list&gt;

Address	Identifier	Description	Address	Identifier	Description
00	VR	ROM version	10	VJ	DO minimum ON/OFF time of proportioning cycle
01	VR	ROM version	11	H2	DI function assignment
02	L1	Digital input (DI) state 1	12	E1	Memory area setting signal
03	L6	Digital input (DI) state 2	13	LQ	DO signal assignment module address 1
04	Q2	Digital output (DO) state 1	14	LR	DO signal assignment module address 2
05	Q3	Digital output (DO) state 2	15	LT	DO output assignment 1 [DO1 to DO4]
06	ER	Error code	16	LX	DO output assignment 2 [DO5 to DO8]
07	UT	Integrated operating time monitor	17	NB	DO energized/de-energized
08	EM	Backup memory state monitor	18	DD	DO output distribution master channel module address
09	SR	RUN/STOP transfer	19	DJ	DO output distribution master channel selection
0A	Q4	DO manual output 1	1A	OJ	DO manipulated output value (MV) at STOP mode
0B	Q5	DO manual output 2	1B	D3	DO output limiter (high)
0C	DO	DO output distribution selection	1C	D4	DO output limiter (low)
0D	O8	DO output distribution bias	1D	X1	Control RUN/STOP holding setting
0E	O9	DO output distribution ratio	1E	ZX	Interval time
0F	V0	DO proportional cycle time			

---

**IMPORTANT** • Setting "Use system data area" to GP-Pro EX system area result in improper operation. Do not set "Use system data area."

---

**NOTE**

- System area setting that can be used for the temperature controller is reading area size only. Please refer to the GP-Pro EX Reference Manual for system data area.  
Cf. GP-Pro EX Reference Manual "LS Area (Direct Access Method Area)"
- Please refer to the precautions on manual notation for icons in the table.  
☞ "Manual Symbols and Terminology"
- Even if non-existing address is used, there are cases when read error is not indicated. In this case, zero (0) is kept for read out data. On the other hand, writing error is indicated.

---

## 6.22 SRZ (Z-CT) Series

 This address can be specified as system data area.

Device	Bit Address	Word Address	32 bits	Notes
Communication identifier	01/0000.00 -01/001D.1F	01/0000-01/001D	<b>L/H</b>	*1 *2 *3 *4
	02/0000.00 -02/001D.1F	02/0000-02/001D		
	03/0000.00 -03/001D.1F	03/0000-03/001D		
	04/0000.00 -04/001D.1F	04/0000-04/001D		
	05/0000.00 -05/001D.1F	05/0000-05/001D		
	06/0000.00 -06/001D.1F	06/0000-06/001D		
	07/0000.00 -07/001D.1F	07/0000-07/001D		
	08/0000.00 -08/001D.1F	08/0000-08/001D		
	09/0000.00 -09/001D.1F	09/0000-09/001D		
	10/0000.00 -10/001D.1F	10/0000-10/001D		
	11/0000.00 -11/001D.1F	11/0000-11/001D		
	12/0000.00 -12/001D.1F	12/0000-12/001D		

- \*1 There are cases for which writing is not available depending on the device address. Check the identifying attributes of the external device's manual before use.
- \*2 When bit is written, the indicator reads the corresponding word address of external device, assign a bit to the read word address, and return to the external device. There are cases when correct data cannot be written if the word address is written using a ladder program, while the indicator reads data of the external device and sends it back.
- \*3 Some of the identifiers are for each channel, some are for each module. As for the identifiers which are for each channel, it is necessary to specified the channel number correctly. As for the identifiers which are for each module, the specified channel number is meaningless.

01/0000  
└── Channel number(the setting range is 01 to 12)

- \*4 32-bit device

## &lt;Communication identifier list&gt;

Address	Identifier	Description	Address	Identifier	Description
00	VR	ROM version	0F	BO	Heater overcurrent alarm selection
01	VR	ROM version	10	CX	Heater break alarm (HBA) interlock release
02	M4	Current transformer (CT) input value monitor	11	CY	Heater overcurrent alarm interlock release
03	M5	Load factor conversion CT monitor	12	LK	Set lock
04	AF	Heater break alarm (HBA) state monitor	13	BV	CT type
05	AG	Heater overcurrent alarm state monitor	14	XT	CT ratio (CT number of winds)
06	ER	Error code	15	DI	Number of heater break alarm (HBA) delay times
07	UT	Integrated operating time monitor	16	BW	Automatic setting factor for heater break alarm (HBA)
08	EM	Backup memory state monitor	17	B9	Automatic setting factor for heater overcurrent alarm
09	CJ	Automatic setting state monitor	18	BP	Determination current value for automatic setting
0A	BT	Heater break/Heater overcurrent alarm automatic setting selection	19	BQ	Automatic setting time
0B	BU	Automatic setting transfer	1A	BX	Module address assignments for CT input
0C	A8	Heater break alarm (HBA) set value	1B	BY	Module channel assignments for CT input
0D	BZ	Heater break alarm (HBA) selection	1C	IC	Load factor conversion method
0E	A6	Heater overcurrent alarm set value	1D	ZX	Interval time

**IMPORTANT**

- Setting "Use system data area" to GP-Pro EX system area result in improper operation. Do not set "Use system data area."

**NOTE**

- System area setting that can be used for the temperature controller is reading area size only. Please refer to the GP-Pro EX Reference Manual for system data area.  
Cf. GP-Pro EX Reference Manual "LS Area (Direct Access Method Area)"
- Please refer to the precautions on manual notation for icons in the table.  
☞ "Manual Symbols and Terminology"
- Even if non-existing address is used, there are cases when read error is not indicated. In this case, zero (0) is kept for read out data. On the other hand, writing error is indicated.

6.23 SRZ (Z-COM) Series

 This address can be specified as system data area.

Device	Bit Address	Word Address	32 bits	Notes
Communication identifier	001/0000.00 -001/0123.1F	001/0000-001/0123	<b>L/H</b>	*1 *2 *3 *4
	002/0000.00 -002/0123.1F	002/0000-002/0123		
	003/0000.00 -003/0123.1F	003/0000-003/0123		
	:	:		
	191/0000.00 -191/0123.1F	191/0000-191/0123		
	192/0000.00 -192/0123.1F	192/0000-192/0123		

- \*1 There are cases for which writing is not available depending on the device address. Check the identifying attributes of the external device's manual before use.
- \*2 When bit is written, the indicator reads the corresponding word address of external device, assign a bit to the read word address, and return to the external device. There are cases when correct data cannot be written if the word address is written using a ladder program, while the indicator reads data of the external device and sends it back.
- \*3 Some of the identifiers are for each channel, some are for each module, and some are for each SRZ unit. Only for the identifiers which are for each SRZ unit, the channel number is meaningless. For the identifiers which are for each channel and for each module, it is necessary to calculate the channel number according to the SRZ unit configuration correctly. The method of calculating the channel number is explained below. (Please refer to the manual of the External Device for more details.)
  - Data for each module (The channel number that is assigned regardless of module type)  
Channel number of communication = Module address setting + Offset value + 1
  - Data for each module (The channel number for every module type)  
Channel number of communication = Module address setting + 1
  - Data for each channel  
Channel number of communication = (Module address setting × Maximum channel number of the function module) + Channel number in the module

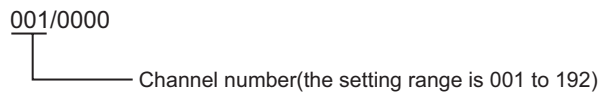

\*4 32-bit device

## &lt;Communication identifier list&gt;

Address	Identifier	Description	Address	Identifier	Description
00	VR	ROM version (Z-COM module)	21	VT	PLC scanning time
01	VR	ROM version (Z-COM module)	22	R5	PLC communication start time
02	VQ	ROM version (Function module)	23	RY	Method for setting the number of connected modules
03	VQ	ROM version (Function module)	24	RK	Slave mapping method
04	UT	Integrated operating time monitor (Z-COM module)	25	QY	Number of connected modules (Z-TIO module)
05	UV	Integrated operating time monitor (Function module)	26	QU	Number of connected modules (Z-DIO module)
06	ER	Error code (Z-COM module)	27	QO	Number of connected modules (Z-CT module)
07	EZ	Error code (Function module)	28	QA	Number of valid groups
08	EM	Backup memory state monitor (Z-COM module)	29	X2	Control RUN/STOP holding setting (Each unit)
09	CZ	Backup memory state monitor (Function module)	2A	M1	Measured value (PV)
0A	QM	System communication state	2B	AJ	Comprehensive event state
0B	QL	SRZ normal communication flag	2C	L0	Operation mode state monitor
0C	ES	PLC communication error code	2D	O1	Manipulated output value (MV) monitor [heat-side]
0D	QN	Unit recognition flag	2E	O2	Manipulated output value (MV) monitor [cool-side]
0E	QK	Monitor for the number of connected modules	2F	M3	Current transformer (CT) input value monitor
0F	SR	RUN/STOP transfer (Each unit)	30	MS	Set value (SV) monitor
10	SW	RUN/STOP transfer (Each module)	31	S2	Remote setting (RS) input value monitor
11	X1	Control RUN/STOP holding setting (Each module)	32	B1	Burnout state monitor
12	VK	Communication 1 protocol	33	AA	Event 1 state monitor
13	VL	Communication 1 communication speed	34	AB	Event 2 state monitor
14	VM	Communication 1 data bit configuration	35	AC	Event 3 state monitor
15	VN	Communication 1 interval time	36	AD	Event 4 state monitor
16	VP	Communication 2 protocol	37	AE	Heat break alarm (HBA) state monitor
17	VU	Communication 2 communication speed	38	Q1	Output state monitor
18	VW	Communication 2 data bit configuration	39	TR	Memory area soak time monitor
19	VX	Communication 2 interval time	3A	Hp	Holding peak value ambient temperature monitor
1A	QV	Station number	3B	ED	Logic output monitor 1
1B	QW	PC number (CPU No.)	3C	EE	Logic output monitor 2
1C	QZ	Register type	3D	G1	PID/AT transfer
1D	QS	Register start number (High-order 4-bit)	3E	J1	Auto/Manual transfer
1E	QX	Register start number (Low-order 16-bit)	3F	C1	Remote/Local transfer
1F	QQ	System data address bias	40	ZA	Memory area transfer
20	QT	COM module link recognition time	41	AR	Interlock release

Address	Identifier	Description	Address	Identifier	Description
42	A1	Event 1 set value (EV1)	71	NR	EDS action wait time (for disturbance 1)
43	A2	Event 2 set value (EV2)	72	NY	EDS action wait time (for disturbance 2)
44	A3	Event 3 set value (EV3)	73	NT	EDS value learning times
45	A4	Event 4 set value (EV4)	74	NU	EDS start signal
46	A5	Control loop break alarm (LBA) time	75	EI	Operation mode
47	N1	LBA deadband	76	ST	Startup tuning (ST)
48	S1	Set value (SV)	77	Y8	Automatic temperature rise learning
49	P1	Proportional band [heat-side]	78	EF	Communication switch for logic
4A	I1	Integral time [heat-side]	79	XI	Input type
4B	D1	Derivative time [heat-side]	7A	PU	Display unit
4C	CA	Control response parameter	7B	XU	Decimal point position
4D	P2	Proportional band [cool-side]	7C	XV	Input scale high
4E	I2	Integral time [cool-side]	7D	XW	Input scale low
4F	D2	Derivative time [cool-side]	7E	AV	Input error determination point (high)
50	V1	Overlap/Deadband	7F	AW	Input error determination point (low)
51	MR	Manual reset	80	BS	Burnout direction
52	HH	Setting change rate limiter (up)	81	XH	Square root extraction
53	HL	Setting change rate limiter (down)	82	E0	Output assignment (Logic output selection function)
54	TM	Area soak time	83	NA	Energized/De-energized (Logic output selection function)
55	LP	Link area number	84	XA	Event 1 type
56	A7	Heater break alarm (HBA) set value	85	FA	Event 1 channel setting
57	NE	Heat break determination point	86	WA	Event 1 hold action
58	NF	Heater melting determination point	87	LF	Event 1 interlock
59	PB	PV bias	88	HA	Event 1 differential gap
5A	F1	PV digital filter	89	TD	Event 1 delay timer
5B	PR	PV ratio	8A	OA	Force ON of Event 1 action
5C	DP	PV low input cut-off	8B	XB	Event 2 type
5D	RB	RS bias	8C	FB	Event 2 channel setting
5E	F2	RS digital filter	8D	WB	Event 2 hold action
5F	RR	RS ratio	8E	LG	Event 2 interlock
60	DV	Output distribution selection	8F	HB	Event 2 differential gap
61	DW	Output distribution bias	90	TG	Event 2 delay timer
62	DQ	Output distribution ratio	91	OB	Force ON of Event 2 action
63	T0	Proportional cycle time	92	XC	Event 3 type
64	V1	Minimum ON/OFF time of proportioning cycle	93	FC	Event 3 channel setting
65	ON	Manual manipulated output value	94	WC	Event 3 hold action
66	RV	Area soak time stop function	95	LH	Event 3 interlock
67	NG	EDS mode (for disturbance 1)	96	HC	Event 3 differential gap
68	NX	EDS mode (for disturbance 2)	97	TE	Event 3 delay timer
69	NI	EDS value 1 (for disturbance 1)	98	OC	Force ON of Event 3 action
6A	NJ	EDS value 1 (for disturbance 2)	99	XD	Event 4 type
6B	NK	EDS value 2 (for disturbance 1)	9A	FD	Event 4 channel setting
6C	NM	EDS value 2 (for disturbance 2)	9B	WD	Event 4 hold action
6D	NN	EDS transfer time (for disturbance 1)	9C	LI	Event 4 interlock
6E	NO	EDS transfer time (for disturbance 2)	9D	HD	Event 4 differential gap
6F	NQ	EDS action time (for disturbance 1)	9E	TF	Event 4 delay timer
70	NL	EDS action time (for disturbance 2)	9F	OD	Force ON of Event 4 action

Address	Identifier	Description	Address	Identifier	Description
A0	XS	CT ratio	C8	P7	Proportional band limiter (low) [heat-side]
A1	ZF	CT assignment	C9	I6	Integral time limiter (high) [heat-side]
A2	ND	Heater break alarm (HBA) type	CA	I7	Integral time limiter (low) [heat-side]
A3	DH	Number of heater break alarm (HBA) delay times	CB	D6	Derivative time limiter (high) [heat-side]
A4	XN	Hot/Cold start	CC	D7	Derivative time limiter (low) [heat-side]
A5	SX	Start determination point	CD	P8	Proportional band limiter (high) [cool-side]
A6	XL	SV tracking	CE	P9	Proportional band limiter (high) [cool-side]
A7	OT	MV transfer function	CF	I8	Integral time limiter (high) [cool-side]
A8	XE	Control action	D0	I9	Integral time limiter (low) [cool-side]
A9	PK	Integral/derivative time decimal point position	D1	D8	Derivative time limiter (high) [cool-side]
AA	KA	Derivative action	D2	D9	Derivative time limiter (low) [cool-side]
AB	KB	Undershoot suppression factor	D3	V2	Open/Close output neutral zone
AC	DG	Derivative gain	D4	SY	Action at feedback resistance (FBR) input error
AD	IV	ON/OFF action differential gap (upper)	D5	FV	Feedback adjustment
AE	IW	ON/OFF action differential gap (lower)	D6	TN	Control motor time
AF	WH	Action (high) at input error	D7	OI	Integrated output limiter
B0	WL	Action (low) at input error	D8	VS	Valve action at STOP
B1	OE	Manipulated output value at input error	D9	KI	ST proportional band adjusting factor
B2	OF	Manipulated output value at STOP mode [heat-side]	DA	KJ	ST integral time adjusting factor
B3	OG	Manipulated output value at STOP mode [cool-side]	DB	KK	ST derivative time adjusting factor
B4	PH	Output change rate limiter (up) [heat-side]	DC	SU	ST start condition
B5	PL	Output change rate limiter (down) [heat-side]	DD	Y7	Automatic temperature rise group
B6	OH	Output limiter (high) [heat-side]	DE	RT	Automatic temperature rise dead time
B7	OL	Output limiter (low) [heat-side]	DF	R2	Automatic temperature rise gradient data
B8	PX	Output change rate limiter (up) [cool-side]	E0	NS	EDS transfer time decimal point position
B9	PY	Output change rate limiter (down) [cool-side]	E1	NV	Output average processing time for EDS
BA	OX	Output limiter (high) [cool-side]	E2	NW	Responsive action trigger point for EDS
BB	OY	Output limiter (low) [cool-side]	E3	HU	Setting change rate limiter unit time
BC	GB	AT bias	E4	RU	Soak time unit
BD	G3	AT cycles	E5	SH	Setting limiter (high)
BE	OP	Output value with AT turned on	E6	SL	Setting limiter (low)
BF	OQ	Output value with AT turned off	E7	TS	PV transfer function
C0	GH	AT differential gap time	E8	EA	Operation mode assignment 1 (Logic output selection function) Logic output 1 to 4
C1	KC	Proportional band adjusting factor [heat-side]	E9	EB	Operation mode assignment 2 (Logic output selection function) Logic output 5 to 8
C2	KD	Integral time adjusting factor [heat-side]	EA	KM	SV select function
C3	KE	Derivative time adjusting factor [heat-side]	EB	MC	Remote SV function master channel module address
C4	KF	Proportional band adjusting factor [cool-side]	EC	MN	Remote SV function master channel selection
C5	KG	Integral time adjusting factor [cool-side]	ED	DY	Output distribution master channel module address
C6	KH	Derivative time adjusting factor [cool-side]	EE	DZ	Output distribution master channel selection
C7	P6	Proportional band limiter (high) [heat-side]	EF	RL	Address of interacting modules



Address	Identifier	Description	Address	Identifier	Description
F0	RM	Channel selection of interacting modules	10A	VF	Z-DIO Interval time
F1	RN	Selection switch of interacting modules	10B	M4	Current transformer (CT) input value monitor
F2	VG	TIO Interval time	10C	M5	Load factor conversion CT monitor
F3	L1	Digital input (DI) state 1	10D	AF	Heater break alarm (HBA) state monitor
F4	L6	Digital input (DI) state 2	10E	AG	Heater overcurrent alarm state monitor
F5	Q2	Digital output (DO) state 1	10F	CJ	Automatic setting state monitor
F6	Q3	Digital output (DO) state 2	110	BT	Heater break/Heater overcurrent alarm automatic setting selection
F7	Q4	DO manual output 1	111	BU	Automatic setting transfer
F8	Q5	DO manual output 2	112	A8	Heater break alarm (HBA) set value
F9	DO	DO output distribution selection	113	BZ	Heater break alarm (HBA) selection
FA	O8	DO output distribution bias	114	A6	Heater overcurrent alarm set value
FB	O9	DO output distribution ratio	115	BO	Heater overcurrent alarm selection
FC	V0	DO proportional cycle time	116	CX	Heater break alarm (HBA) interlock release
FD	VJ	DO minimum ON/OFF time of proportioning cycle	117	CY	Heater overcurrent alarm interlock release
FE	H2	DI function assignment	118	LK	Set lock
FF	E1	Memory area setting signal	119	BV	CT type
100	LQ	DO signal assignment module address 1	11A	XT	CT ratio (CT number of winds)
101	LR	DO signal assignment module address 2	11B	DI	Number of heater break alarm (HBA) delay times
102	LT	DO output assignment 1 [DO1 to DO4]	11C	BW	Automatic setting factor for heater break alarm (HBA)
103	LX	DO output assignment 2 [DO5 to DO8]	11D	B9	Automatic setting factor for heater overcurrent alarm
104	NB	DO energized/de-energized	11E	BP	Determination current value for automatic setting
105	DD	DO output distribution master channel module address	11F	BQ	Automatic setting time
106	DJ	DO output distribution master channel selection	120	BX	Module address assignments for CT input
107	OJ	DO manipulated output value (MV) at STOP mode	121	BY	Module channel assignments for CT input
108	D3	DO output limiter (high)	122	IC	Load factor conversion method
109	D4	DO output limiter (low)	123	VH	CT Interval time

**IMPORTANT** • Setting "Use system data area" to GP-Pro EX system area result in improper operation. Do not set "Use system data area."

**NOTE**

- System area setting that can be used for the temperature controller is reading area size only. Please refer to the GP-Pro EX Reference Manual for system data area.  
Cf. GP-Pro EX Reference Manual "LS Area (Direct Access Method Area)"
- Please refer to the precautions on manual notation for icons in the table.  
☞ "Manual Symbols and Terminology"
- Even if non-existing address is used, there are cases when read error is not indicated. In this case, zero (0) is kept for read out data. On the other hand, writing error is indicated.

## 7 Device Code and Address Code

Use device code and address code when you select "Device Type & Address" for the address type in data displays.

### 7.1 CB Series

Device	Device Name	Device Code (HEX)	Address Code
Communication identifier	-	0080	Word Address

### 7.2 FB Series

Device	Device Name	Device Code (HEX)	Address Code
Communication identifier	-	0080	Word Address

### 7.3 HA Series

Device	Device Name	Device Code (HEX)	Address Code
Communication identifier	-	0080	Word Address

### 7.4 MA Series

Device	Device Name	Device Code (HEX)	Address Code
Communication identifier	-	0080	Word Address

### 7.5 SRV Series

Device	Device Name	Device Code (HEX)	Address Code
Communication identifier	-	0080	Word Address

### 7.6 SRX Series

Device	Device Name	Device Code (HEX)	Address Code
Communication identifier	-	0080	Word Address

## 7.7 SA Series

Device	Device Name	Device Code (HEX)	Address Code
Communication identifier	-	0080	Word Address

## 7.8 SR Mini HG(H-PCP-A/B) Series

Device	Device Name	Channel No.	Device Code (HEX)	Address Code
Communication identifier	-	01/	0080	Word Address
	-	02/	0180	
	-	03/	0280	
	-	04/	0380	
	-	05/	0480	
	-	06/	0580	
	-	07/	0680	
	-	08/	0780	
	-	09/	0880	
	-	10/	0980	
	-	11/	0A80	
	-	12/	0B80	
	-	13/	0C80	
	-	14/	0D80	
	-	15/	0E80	
	-	16/	0F80	
	-	17/	1080	
	-	18/	1180	
	-	19/	1280	
	-	20/	1380	

## 7.9 SR Mini HG(H-PCP-J) Series

Device	Device Name	Channel No.	Device Code (HEX)	Address Code
Communication identifier	-	01/	0080	Word Address
	-	02/	0180	
	-	03/	0280	
	-	04/	0380	
	-	05/	0480	
	-	06/	0580	
	-	07/	0680	
	-	08/	0780	
	-	09/	0880	
	-	10/	0980	
	-	11/	0A80	
	-	12/	0B80	
	-	13/	0C80	
	-	14/	0D80	
	-	15/	0E80	
	-	16/	0F80	
	-	17/	1080	
	-	18/	1180	
	-	19/	1280	
	-	20/	1380	
	:	:	:	
-	95/	5E80		
-	96/	5F80		

## 7.10 REX-F9000 Series

Device	Device Name	Device Code (HEX)	Address Code
Communication identifier	-	0080	Word Address

## 7.11 REX-F Series

Device	Device Name	Device Code (HEX)	Address Code
Communication identifier	-	0080	Word Address

## 7.12 REX-D Series

Device	Device Name	Device Code (HEX)	Address Code
Communication identifier	-	0080	Word Address

## 7.13 REX-G9 Series

Device	Device Name	Device Code (HEX)	Address Code
Communication identifier	-	0080	Word Address

## 7.14 REX-P300 Series

Device	Device Name	Device Code (HEX)	Address Code
Communication identifier	-	0080	Word Address

## 7.15 REX-P250 Series

Device	Device Name	Device Code (HEX)	Address Code
Communication identifier	-	0080	Word Address

## 7.16 REX-AD Series

Device	Device Name	Device Code (HEX)	Address Code
Communication identifier	-	0080	Word Address

## 7.17 REX-PG Series

Device	Device Name	Device Code (HEX)	Address Code
Communication identifier	-	0080	Word Address

## 7.18 AE500 Series

Device	Device Name	Device Code (HEX)	Address Code
Communication identifier	-	0080	Word Address

## 7.19 LE100 Series

Device	Device Name	Device Code (HEX)	Address Code
Communication identifier	-	0080	Word Address

## 7.20 SRZ (Z-TIO) Series

Device	Device Name	Channel No.	Device Code (HEX)	Address Code
Communication identifier	-	01/	0080	Word Address
	-	02/	0180	
	-	03/	0280	
	-	04/	0380	

## 7.21 SRZ (Z-DIO) Series

Device	Device Name	Channel No.	Device Code (HEX)	Address Code
Communication identifier	-	01/	0080	Word Address
	-	02/	0180	
	-	03/	0280	
	-	04/	0380	
	-	05/	0480	
	-	06/	0580	
	-	07/	0680	
	-	08/	0780	

## 7.22 SRZ (Z-CT) Series

Device	Device Name	Channel No.	Device Code (HEX)	Address Code
Communication identifier	-	01/	0080	Word Address
	-	02/	0180	
	-	03/	0280	
	-	04/	0380	
	-	05/	0480	
	-	06/	0580	
	-	07/	0680	
	-	08/	0780	
	-	09/	0880	
	-	10/	0980	
	-	11/	0A80	
	-	12/	0B80	

## 7.23 SRZ (Z-COM) Series

Device	Device Name	Channel No.	Device Code (HEX)	Address Code
Communication identifier	-	001/	0080	Word Address
	-	002/	0180	
	-	003/	0280	
	-	004/	0380	
	-	005/	0480	
	-	006/	0580	
	-	007/	0680	
	-	008/	0780	
	-	009/	0880	
	-	010/	0980	
	-	011/	0A80	
	:	:	:	
	-	191/	BE80	
	-	192/	BF80	

## 8 Error Messages

Error messages are displayed on the screen of Display as follows: "No. : Device Name: Error Message (Error Occurrence Area)". Each description is shown below.

Item	Description
No.	Error No.
Device Name	Name of External Device where error occurs. Device name is a title of External Device set with GP-Pro EX.(Initial value [PLC1])
Error Message	Displays messages related to the error which occurs.
Error Occurrence Area	Displays IP address or device address of External Device where error occurs, or error codes received from External Device. <div style="border: 1px solid black; padding: 2px; margin: 5px 0;"><b>NOTE</b></div> <ul style="list-style-type: none"> <li>• IP address is displayed such as "IP address (Decimal): MAC address (Hex)".</li> <li>• Device address is displayed such as "Address: Device address".</li> <li>• Received error codes are displayed such as "Decimal [Hex]".</li> </ul>

Display Examples of Error Messages

"RHAA035: PLC1: Error has been responded for device write command (Error Code: 2 [02H])"

**NOTE**

- Refer to your External Device manual for details on received error codes.
- Refer to "Display-related errors" in "Maintenance/Troubleshooting Guide" for details on the error messages common to the driver.

### ■ Error Codes Unique to External Device

Error No.	Error Message	Description
RHxx128	(Node Name): The Setting value for identifier(identifier) is illegal. Please check the controller manuals.	Appears if the number entered exceeds the allowable number of digits.
RHxx129	(Node Name):The channel number (number) of identifier (identifier) does not exist in SRZ unit, please check it again.	Appears if an identifier that does not exist has been used.