



FX Series CPU Direct Driver

1	System Configuration.....	3
2	Selection of External Device	8
3	Example of Communication Setting.....	9
4	Setup Items.....	12
5	Cable Diagram	16
6	Supported Device.....	41
7	Device Code and Address Code.....	50
8	Error Messages.....	51

Introduction

This manual describes how to connect the Display and the External Device (target PLC).

In this manual, the connection procedure will be described by following the below sections:

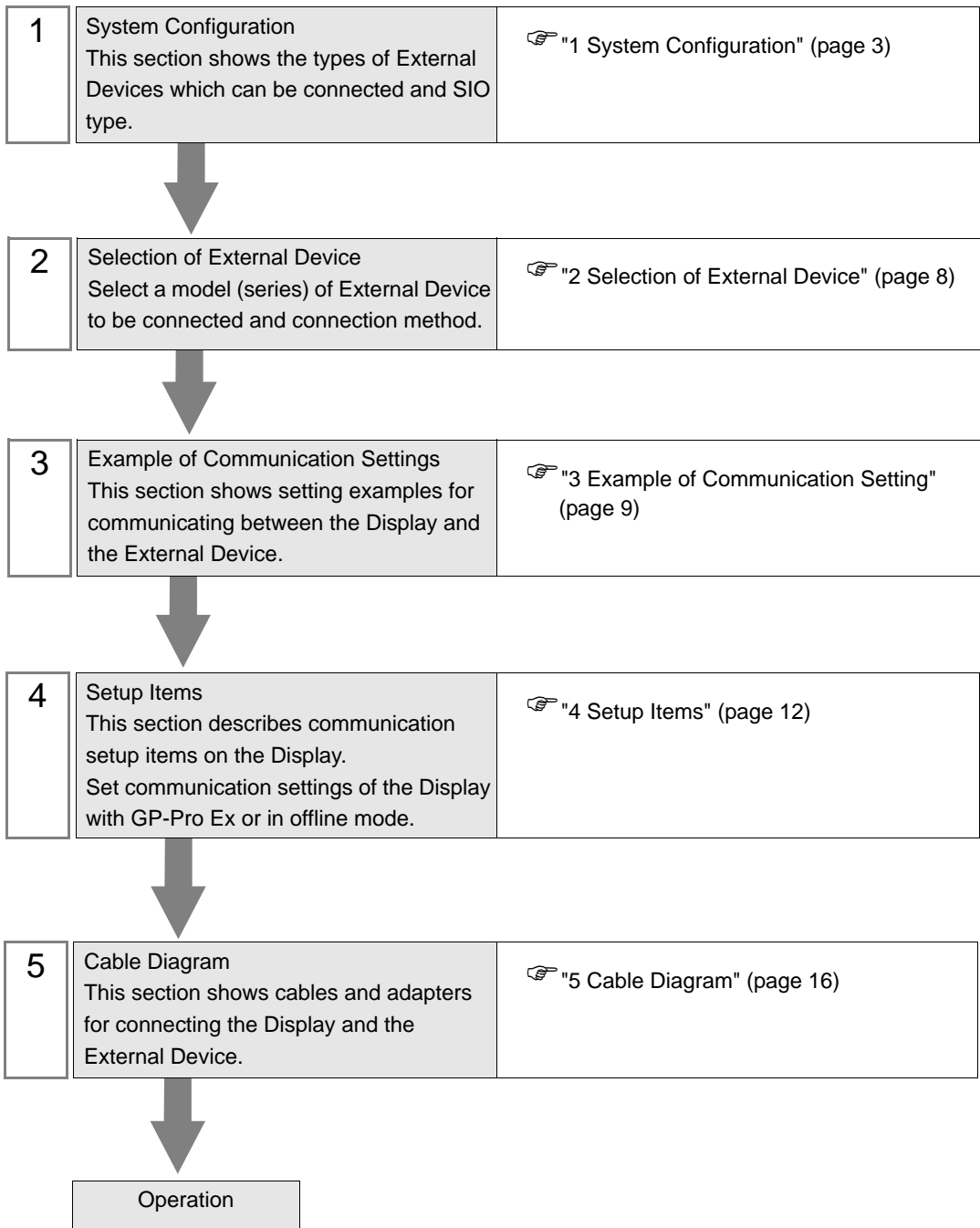

1 System Configuration

The system configuration in the case when the External Device of Mitsubishi Electric Corporation and the Display are connected is shown.

Series	CPU	Link I/F	SIO Type	Setting Example	Cable Diagram
MELSEC FX Series	FX1	CPU Direct	RS232C	Setting Example 1 (page 9)	Cable Diagram 1 (page 16)
	FX2	CPU Direct	RS232C	Setting Example 1 (page 9)	Cable Diagram 1 (page 16)
		2-port adapter II by Pro-face (Model: GP070-MD11)	RS422/485 (4wire)	Setting Example 3 (page 11)	Cable Diagram 10 (page 32)
	FX2C	CPU Direct	RS232C	Setting Example 1 (page 9)	Cable Diagram 1 (page 16)
	FX0S	CPU Direct	RS422/485 (4wire)	Setting Example 2 (page 10)	Cable Diagram 2 (page 17)
		2-port adapter II by Pro-face (Model: GP070-MD11)	RS422/485 (4wire)	Setting Example 3 (page 11)	Cable Diagram 10 (page 32)
	FX0N	CPU Direct	RS422/485 (4wire)	Setting Example 2 (page 10)	Cable Diagram 2 (page 17)
		FX2NC-232ADP	RS232C	Setting Example 1 (page 9)	Cable Diagram 9 (page 30)
		2-port adapter II by Pro-face (Model: GP070-MD11)	RS422/485 (4wire)	Setting Example 3 (page 11)	Cable Diagram 10 (page 32)
	FX1S, FX1N	CPU Direct	RS422/485 (4wire)	Setting Example 2 (page 10)	Cable Diagram 2 (page 17)
		FX1N-232-BD	RS232C	Setting Example 1 (page 9)	Cable Diagram 3 (page 18)
		FX0N-232ADP + FX1N-CNV-BD	RS232C	Setting Example 1 (page 9)	Cable Diagram 4 (page 20)
		FX2NC-232ADP + FX1N-CNV-BD	RS232C	Setting Example 1 (page 9)	Cable Diagram 7 (page 26)
		FX1N-422-BD	RS422/485 (4wire)	Setting Example 2 (page 10)	Cable Diagram 6 (page 24)
		2-port adapter II by Pro-face (Model: GP070-MD11)	RS422/485 (4wire)	Setting Example 3 (page 11)	Cable Diagram 10 (page 32)
		2-port adapter II by Pro-face (Model: GP070-MD11) + FX1N-422-BD	RS422/485 (4wire)	Setting Example 3 (page 11)	Cable Diagram 11 (page 36)

Series	CPU	Link I/F	SIO Type	Setting Example	Cable Diagram
MELSEC FX Series	FX2N	CPU Direct	RS422/485 (4wire)	Setting Example 2 (page 10)	Cable Diagram 2 (page 17)
		FX2N-232-BD	RS232C	Setting Example 1 (page 9)	Cable Diagram 3 (page 18)
		FX0N-232ADP + FX2N-CNV-BD	RS232C	Setting Example 1 (page 9)	Cable Diagram 4 (page 20)
		FX2NC-232ADP +FX2N-CNV-BD	RS232C	Setting Example 1 (page 9)	Cable Diagram 7 (page 26)
		FX2N-422-BD	RS422/485 (4wire)	Setting Example 2 (page 10)	Cable Diagram 6 (page 24)
		2-port adapter II by Pro-face (Model: GP070-MD11)	RS422/485 (4wire)	Setting Example 3 (page 11)	Cable Diagram 10 (page 32)
		2-port adapter II by Pro-face (Model: GP070-MD11) + FX2N-422-BD	RS422/485 (4wire)	Setting Example 3 (page 11)	Cable Diagram 11 (page 36)
	FX1NC, FX2NC	CPU Direct	RS422/485 (4wire)	Setting Example 2 (page 10)	Cable Diagram 2 (page 17)
		FX0N-232ADP	RS232C	Setting Example 1 (page 9)	Cable Diagram 5 (page 22)
		FX2NC-232ADP	RS232C	Setting Example 1 (page 9)	Cable Diagram 9 (page 30)
		2-port adapter II by Pro-face (Model: GP070-MD11)	RS422/485 (4wire)	Setting Example 3 (page 11)	Cable Diagram 10 (page 32)
	FX3U, FX3UC	CPU Direct	RS422/485 (4wire)	Setting Example 2 (page 10)	Cable Diagram 2 (page 17)
		FX3U-232-BD	RS232C	Setting Example 1 (page 9)	Cable Diagram 3 (page 18)
		FX3U-232ADP + FX3U-232-BD, FX3U- 422-BD, FX3U-485-BD, FX3U-USB-BD or FX3U-CNV-BD	RS232C	Setting Example 1 (page 9)	Cable Diagram 8 (page 28)
		FX3U-422-BD	RS422/485 (4wire)	Setting Example 2 (page 10)	Cable Diagram 6 (page 24)
		2-port adapter II by Pro-face (Model: GP070-MD11)	RS422/485 (4wire)	Setting Example 3 (page 11)	Cable Diagram 10 (page 32)
		2-port adapter II by Pro-face (Model: GP070-MD11) + FX3U-422-BD	RS422/485 (4wire)	Setting Example 3 (page 11)	Cable Diagram 11 (page 36)

Series	CPU	Link I/F	SIO Type	Setting Example	Cable Diagram
MELSEC FX Series	FX3G	CPU Direct	RS422/485 (4wire)	Setting Example 2 (page 10)	Cable Diagram 2 (page 17)
		FX3G-232-BD	RS232C	Setting Example 1 (page 9)	Cable Diagram 3 (page 18)
		FX3U-232ADP + FX3G-CNV-ADP	RS232C	Setting Example 1 (page 9)	Cable Diagram 8 (page 28)
		FX3G-422-BD	RS422/485 (4wire)	Setting Example 2 (page 10)	Cable Diagram 6 (page 24)
		2-port adapter II by Pro-face (Model: GP070-MD11)	RS422/485 (4wire)	Setting Example 3 (page 11)	Cable Diagram 10 (page 32)
		2-port adapter II by Pro-face (Model: GP070-MD11) + FX3G-422-BD	RS422/485 (4wire)	Setting Example 3 (page 11)	Cable Diagram 11 (page 36)

NOTE

- When the time of GP4000 series is automatically updated in [Clock Update Settings] of GP-Pro EX, there are some restrictions as shown below.
For details on [Clock Update Settings], refer to GP-Pro EX Reference Manual.
- FX0S, FX0N and FX1 does not support automatic update of the time. Specify [Customize] in [Clock Update Settings].
- When the time is automatically updated in FX2, FX2C and FX2NC, the real time clock function board or the E2PROM memory with the real time clock function is required.

■ IPC COM Port

When connecting IPC with an External Device, the COM port used depends on the series and SIO type. Please refer to the IPC manual for details.

Usable port

Series	Usable Port		
	RS-232C	RS-422/485(4 wire)	RS-422/485(2 wire)
PS-2000B	COM1 ^{*1} , COM2, COM3 ^{*1} , COM4	-	-
PS-3450A, PS-3451A, PS3000-BA, PS3001-BD	COM1, COM2 ^{*1*2}	COM2 ^{*1*2}	COM2 ^{*1*2}
PS-3650A (T41 model), PS-3651A (T41 model)	COM1 ^{*1}	-	-
PS-3650A (T42 model), PS-3651A (T42 model)	COM1 ^{*1*2} , COM2	COM1 ^{*1*2}	COM1 ^{*1*2}
PS-3700A (Pentium®4-M) PS-3710A	COM1 ^{*1} , COM2 ^{*1} , COM3 ^{*2} , COM4	COM3 ^{*2}	COM3 ^{*2}
PS-3711A	COM1 ^{*1} , COM2 ^{*2}	COM2 ^{*2}	COM2 ^{*2}
PS4000 ^{*3}	COM1, COM2	-	-
PL3000	COM1 ^{*1*2} , COM2 ^{*1} , COM3, COM4	COM1 ^{*1*2}	COM1 ^{*1*2}

*1 The RI/5V can be switched. Use the IPC's switch to change if necessary.

*2 Set up the SIO type with the DIP Switch. Please set up as follows according to SIO type to be used.

*3 When making communication between an External Device and COM port on the Expansion slot, only RS-232C is supported. However, ER (DTR/CTS) control cannot be executed because of the specification of COM port.

For connection with External Device, use user-created cables and disable Pin Nos. 1, 4, 6 and 9. Please refer to the IPC manual for details of pin layout.

DIP Switch setting: RS-232C

DIP Switch	Setting	Description
1	OFF ^{*1}	Reserved (always OFF)
2	OFF	SIO type: RS-232C
3	OFF	
4	OFF	Output mode of SD (TXD) data: Always output
5	OFF	Terminal resistance (220Ω) insertion to SD (TXD): None
6	OFF	Terminal resistance (220Ω) insertion to RD (RXD): None
7	OFF	Short-circuit of SDA (TXA) and RDA (RXA): Not available
8	OFF	Short-circuit of SDB (TXB) and RDB (RXB): Not available
9	OFF	RS (RTS) Auto control mode: Disabled
10	OFF	

*1 When using PS-3450A, PS-3451A, PS3000-BA and PS3001-BD, turn ON the set value.

DIP Switch setting: RS-422/485 (4 wire)

DIP Switch	Setting	Description
1	OFF	Reserved (always OFF)
2	ON	SIO type: RS-422/485
3	ON	
4	OFF	Output mode of SD (TXD) data: Always output
5	OFF	Terminal resistance (220Ω) insertion to SD (TXD): None
6	OFF	Terminal resistance (220Ω) insertion to RD (RXD): None
7	OFF	Short-circuit of SDA (TXA) and RDA (RXA): Not available
8	OFF	Short-circuit of SDB (TXB) and RDB (RXB): Not available
9	OFF	RS (RTS) Auto control mode: Disabled
10	OFF	

DIP Switch setting: RS-422/485 (2 wire)

DIP Switch	Setting	Description
1	OFF	Reserved (always OFF)
2	ON	SIO type: RS-422/485
3	ON	
4	OFF	Output mode of SD (TXD) data: Always output
5	OFF	Terminal resistance (220Ω) insertion to SD (TXD): None
6	OFF	Terminal resistance (220Ω) insertion to RD (RXD): None
7	ON	Short-circuit of SDA (TXA) and RDA (RXA): Available
8	ON	Short-circuit of SDB (TXB) and RDB (RXB): Available
9	ON	RS (RTS) Auto control mode: Enabled
10	ON	

2 Selection of External Device

Select the External Device to be connected to the Display.

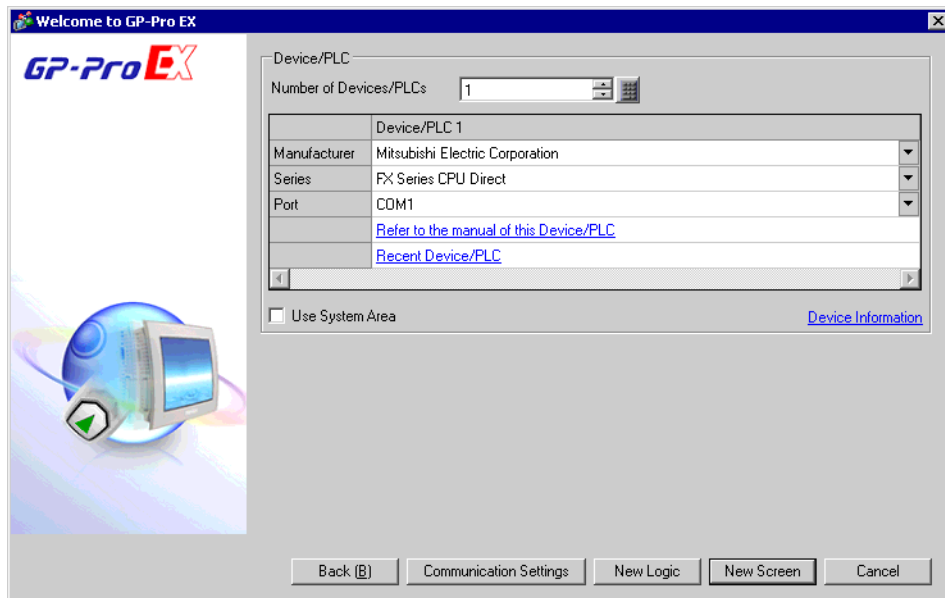

Setup Items	Setup Description
Number of Devices/PLCs	Enter an integer from 1 to 4 to define the number of Devices/PLCs to connect to the display.
Manufacturer	Select the manufacturer of the External Device to connect. Select "Mitsubishi Electric Corporation".
Series	Select the External Device model (series) and the connection method. Select "FX Series CPU Direct". In System configuration, make sure the External Device you are connecting is supported by "FX Series CPU Direct". ☞ "1 System Configuration" (page 3)
Port	Select the Display port to connect to the External Device.
Use System Area	Check this option to synchronize the system data area of the Display and the device (memory) of the External Device. When synchronized, you can use the External Device's ladder program to switch the display or display the window on the Display. Cf. GP-Pro EX Reference Manual "LS Area (Direct Access Method Area)" This feature can also be set in GP-Pro EX or in the Display's offline mode. Cf. GP-Pro EX Reference Manual "System Settings [Display Unit] - [System Area] Settings Guide" Cf. Maintenance/Troubleshooting Guide "Main Unit - System Area Settings"

3 Example of Communication Setting

Examples of communication settings of the Display and the External Device, recommended by Pro-face, are shown.

3.1 Setting Example 1

■ Setting of GP-Pro EX

◆ Communication Settings

To display the setup screen, from the [Project] menu, point to [System Settings] and select [Device/PLC].

Device/PLC 1

Summary [Change Device/PLC](#)

Manufacturer Series Port

Text Data Mode [Change](#)

Communication Settings

RS232C RS422/485(2wire) RS422/485(4wire)
 Speed
 Data Length 7 8
 Parity NONE EVEN ODD
 Stop Bit 1 2
 Flow Control NONE ER(DTR/CTS) XON/XOFF
 Timeout (sec)
 Retry
 Wait To Send (ms)
 Adapter Direct 2 Port

RI / VCC RI VCC
In the case of RS232C, you can select the 9th pin to RI (Input) or VCC (5V Power Supply). If you use the Digital's RS232C Isolation Unit or CPU I/F Cable for Mitsubishi PLC FX Series (Digital's:GP430-IP11-0), please select it to VCC.

Device-Specific Settings

Allowable Number of Devices/PLCs [Add Device](#)

No.	Device Name	Settings
<input type="button" value="1"/>	<input type="text" value="PLC1"/>	<input type="button" value="Settings"/>

[Add Indirect Device](#)

■ Setting of External Device

When the link I/F you use is the CPU Direct type, setting of External Device is not necessary. When you use a function extension board and a communication adapter, make the settings as shown below.

- 1 Uncheck the checkbox for [Operate communication setting] in [PLC system (2)] of Mitsubishi's GP-Developer.
- 2 Store data "0" in D8120 and between D8173 and D8180. Then, set M8070 and M8071 to OFF.

When using Channel 2 for FX3U, FX3UC or FX3G, store data "0" in D8420 instead of D8120. When using Channel 1, store data "0" in D8120.

3.2 Setting Example 2

■ Setting of GP-Pro EX

◆ Communication Settings

To display the setup screen, from the [Project] menu, point to [System Settings] and select [Device/PLC].

Device/PLC 1

Summary [Change Device/PLC](#)

Manufacturer Series Port

Text Data Mode [Change](#)

Communication Settings

RS232C
 RS422/485(2wire)
 RS422/485(4wire)

Speed

Data Length 7 8

Parity NONE EVEN ODD

Stop Bit 1 2

Flow Control NONE ER(DTR/CTS) XON/XOFF

Timeout (sec)

Retry

Wait To Send (ms)

Adapter Direct 2 Port

RI / VCC
 RI
 VCC

In the case of RS232C, you can select the 9th pin to RI (Input) or VCC (5V Power Supply). If you use the Digital's RS232C Isolation Unit or CPU I/F Cable for Mitsubishi PLC FX Series (Digital's:GP430-IP11-D), please select it to VCC.

Device-Specific Settings

Allowable Number of Devices/PLCs [Add Device](#)

No.	Device Name	Settings
<input type="button" value="↓"/> 1	<input type="text" value="PLC1"/>	<input type="button" value="⋮"/>

■ Setting of External Device

When the link I/F you use is the CPU Direct type, setting of External Device is not necessary. When you use a function extension board and a communication adapter, make the settings as shown below.

- 1 Uncheck the checkbox for [Operate communication setting] in [PLC system (2)] of Mitsubishi's GP-Developer.
- 2 Store data "0" in D8120 and between D8173 and D8180. Then, set M8070 and M8071 to OFF.

When using Channel 2 for FX3U, FX3UC or FX3G, store data "0" in D8420 instead of D8120. When using Channel 1, store data "0" in D8120.

3.3 Setting Example 3

■ Setting of GP-Pro EX

◆ Communication Settings

To display the setup screen, from the [Project] menu, point to [System Settings] and select [Device/PLC].

Device/PLC 1

Summary [Change Device/PLC](#)

Manufacturer Series Port

Text Data Mode [Change](#)

Communication Settings

RS232C RS422/485(2wire) RS422/485(4wire)

Speed

Data Length 7 8

Parity NONE EVEN ODD

Stop Bit 1 2

Flow Control NONE ER(DTR/CTS) XON/XOFF

Timeout (sec)

Retry

Wait To Send (ms)

Adapter Direct 2 Port

RI / VCC RI VCC

In the case of RS232C, you can select the 9th pin to RI (Input) or VCC (5V Power Supply). If you use the Digital's RS232C Isolation Unit or CPU I/F Cable for Mitsubishi PLC FX Series (Digital's:GP430-IP11-0), please select it to VCC.

Device-Specific Settings

Allowable Number of Devices/PLCs [Add Device](#)

No.	Device Name	Settings
<input type="button" value="1"/>	<input type="text" value="PLC1"/>	<input type="button" value="Settings"/>

■ Setting of External Device

When the link I/F you use is the CPU Direct type, setting of External Device is not necessary. When you use a function extension board and a communication adapter, make the settings as shown below.

- 1 Uncheck the checkbox for [Operate communication setting] in [PLC system (2)] of Mitsubishi's GP-Developer.
- 2 Store data "0" in D8120 and between D8173 and D8180. Then, set M8070 and M8071 to OFF.

When using Channel 2 for FX3U, FX3UC or FX3G, store data "0" in D8420 instead of D8120. When using Channel 1, store data "0" in D8120.

4 Setup Items

Set communication settings of the Display with GP-Pro EX or in offline mode of the Display.

The setting of each parameter must be identical to that of External Device.

☞ "3 Example of Communication Setting" (page 9)

4.1 Setup Items in GP-Pro EX

■ Communication Settings

To display the setup screen, from the [Project] menu, point to [System Settings] and select [Device/PLC].

Device/PLC 1

Summary [Change Device/PLC](#)

Manufacturer: Mitsubishi Electric Corporation Series: FX Series CPU Direct Port: COM1

Text Data Mode: 1 [Change](#)

Communication Settings

SIO Type: RS232C RS422/485(2wire) RS422/485(4wire)

Speed: 9600

Data Length: 7 8

Parity: NONE EVEN ODD

Stop Bit: 1 2

Flow Control: NONE ER(DTR/CTS) XON/XOFF

Timeout: 3 (sec)

Retry: 2

Wait To Send: 0 (ms)

Adapter: Direct 2 Port

RI / VCC: RI VCC

In the case of RS232C, you can select the 9th pin to RI (Input) or VCC (5V Power Supply). If you use the Digital's RS232C Isolation Unit or CPU I/F Cable for Mitsubishi PLC FX Series (Digital's:GP430-IP11-0), please select it to VCC.

Default

Device-Specific Settings

Allowable Number of Devices/PLCs: 1 [Add Device](#)

No.	Device Name	Settings
1	PLC1	

[Add Indirect Device](#)

Setup Items	Setup Description
SIO Type	Select the SIO type to communicate with the External Device.
Speed	Select speed between External Device and Display. NOTE <ul style="list-style-type: none"> Supported range of speed varies depending on the type. FX3U, FX3UC and FX3G support up to 115.2K. FX1N, FX1NC, FX2N and FX2NC support up to 38400. Note that they support up to 19200 when using FX-232W or FX232AWC. Other CPUs support up to 9600.
Data Length	Select data length.
Parity	Select how to check parity.
Stop Bit	Select stop bit length.
Flow Control	Select the communication control method to prevent overflow of transmission and reception data.

continued to next page

Setup Items	Setup Description
Timeout	Use an integer from 1 to 127 to enter the time (s) for which the Display waits for the response from the External Device.
Retry	In case of no response from the External Device, use an integer from 0 to 255 to enter how many times the Display retransmits the command.
Wait To Send	Use an integer from 0 to 255 to enter standby time (ms) for the Display from receiving packets to transmitting next commands.
Adapter	Select "Direct" or "2 Port " for the adapter to be used. When using 2-port adapter II, select "2 Port".
RI/VCC	You can switch RI/VCC of the 9th pin when you select RS232C for SIO type. It is necessary to change RI/5V by changeover switch of IPC when connect with IPC. Please refer to the manual of the IPC for more detail.

NOTE

- Refer to the GP-Pro EX Reference Manual for Indirect Device.
Cf. GP-Pro EX Reference Manual "Changing the Device/PLC at Runtime (Indirect Device)"

4.2 Setup Items in Offline Mode

- NOTE** • Refer to the Maintenance/Troubleshooting guide for information on how to enter offline mode or about the operation.

Cf. Maintenance/Troubleshooting Guide "Offline Mode"

- The number of the setup items to be displayed for 1 page in the offline mode depends on the Display in use. Please refer to the Reference manual for details.

■ Communication Settings

To display the setting screen, touch [Device/PLC Settings] from [Peripheral Settings] in offline mode. Touch the External Device you want to set from the displayed list.

(Page 1/2)

Comm.				
FX Series CPU Direct		[COM1]	Page 1/2	
SIO Type	RS232C			
Speed	9600			
Data Length	<input checked="" type="radio"/> 7 <input type="radio"/> 8			
Parity	<input type="radio"/> NONE <input checked="" type="radio"/> EVEN <input type="radio"/> ODD			
Stop Bit	<input checked="" type="radio"/> 1 <input type="radio"/> 2			
Flow Control	ER(DTR/CTS)			
Timeout(s)	3			
Retry	2			
Wait To Send(ms)	0			
Adapter	2 Port			
				➔
Exit		Back		2008/10/23 10:51:11

Setup Items	Setup Description
SIO Type	<p>Select the SIO type to communicate with the External Device.</p> <p>IMPORTANT</p> <p>To make the communication settings correctly, confirm the serial interface specifications of Display unit for [SIO Type].</p> <p>We cannot guarantee the operation if a communication type that the serial interface does not support is specified.</p> <p>For details concerning the serial interface specifications, refer to the manual for Display unit.</p>
Speed	<p>Select speed between External Device and Display.</p> <p>NOTE</p> <ul style="list-style-type: none"> • Supported range of speed varies depending on the type. FX3U, FX3UC and FX3G support up to 115.2K. FX1N, FX1NC, FX2N and FX2NC support up to 38400. Note that they support up to 19200 when using FX-232W or FX232AWC. Other CPUs support up to 9600.

Setup Items	Setup Description
Data Length	Select data length.
Parity	Select how to check parity.
Stop Bit	Select stop bit length.
Flow Control	Select the communication control method to prevent overflow of transmission and reception data.
Timeout	Use an integer from 1 to 127 to enter the time (s) for which the Display waits for the response from the External Device.
Retry	In case of no response from the External Device, use an integer from 0 to 255 to enter how many times the Display retransmits the command.
Wait To Send	Use an integer from 0 to 255 to enter standby time (ms) for the Display from receiving packets to transmitting next commands.
Adapter	Select "Direct" or "2 Port " for the adapter to be used. When using 2-port adapter II, select "2 Port".

(Page 2/2)

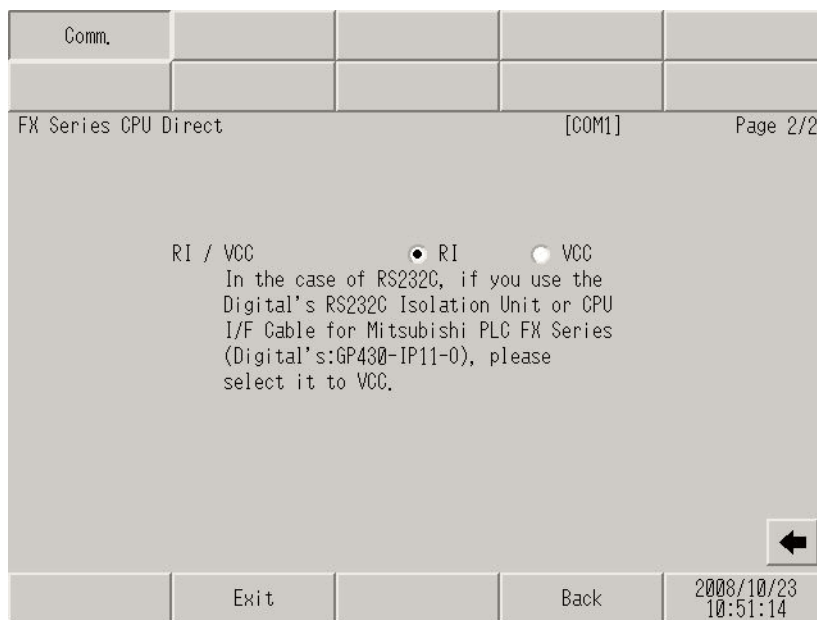

Setup Items	Setup Description
RI/VCC	You can switch RI/VCC of the 9th pin when you select RS232C for SIO type. It is necessary to change RI/5V by changeover switch of IPC when connect with IPC. Please refer to the manual of the IPC for more detail.

NOTE

- GP-4100 series and GP-4*0ITM do not have the [RI/VCC] setting in the offline mode.

5 Cable Diagram

The cable diagram shown below may be different from the cable diagram recommended by Mitsubishi Electric Corporation. Please be assured there is no operational problem in applying the cable diagram shown in this manual.

- The FG pin of the External Device body must be D-class grounded. Please refer to the manual of the External Device for more details.
- SG and FG are connected inside the Display. When connecting SG to the External Device, design the system not to form short-circuit loop.
- Connect the isolation unit, when communication is not stabilized under the influence of a noise etc..

Cable Diagram 1

Display (Connection Port)	Cable		Notes
GP3000 (COM1) GP4000 ^{*1} (COM1) ST (COM1) IPC ^{*2} PC/AT	1A	9-25 232C conversion cable by Pro-face CA3-CBLCBT232-01 (0.2m) + Mitsubishi PLC FX Series program control I/F cable by Pro-face GP430-IP11-O (5m)	

*1 All GP4000 models except GP-4100 series, GP-4*01TM and GP-4203T

*2 Only the COM port which can communicate by RS-232C can be used.

☞ ■ IPC COM Port (page 6)

NOTE • This cable system cannot be used for connection with GP-4100 series and GP-4*01TM.

1A)

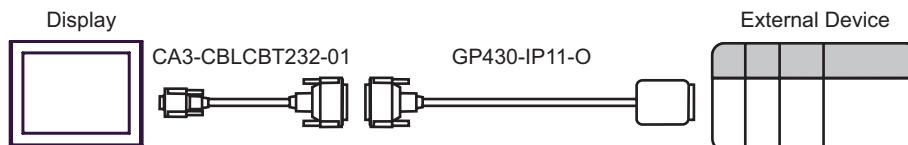

Cable Diagram 2

Display (Connection Port)	Cable		Notes
GP3000* ¹ (COM1) AGP-3302B (COM2)	2A	Mitsubishi FX connection cable by Pro-face CA3-CBLFX/1M-01 (1m) or CA3-CBLFX/5M-01 (5m)	
GP4000* ² (COM2) GP-4*01TM (COM1) GP-4201T (COM1) ST* ³ (COM2) IPC* ⁴	2B	Mitsubishi PLC FX Series CPU I/F Cable by Pro-face ZC9CBFX11 (1m) or ZC9CBFX51 (5m)	

*1 All GP3000 models except AGP-3302B

*2 All GP4000 models except GP-4100 series, GP-4*01TM, GP-4201T and GP-4*03T

*3 All ST models except AST-3211A and AST-3302B

*4 Only the COM port which can communicate by RS-422/485 (4 wire) can be used.

 ■ IPC COM Port (page 6)

2A)

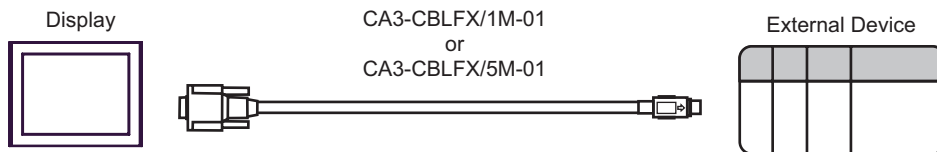

2B)

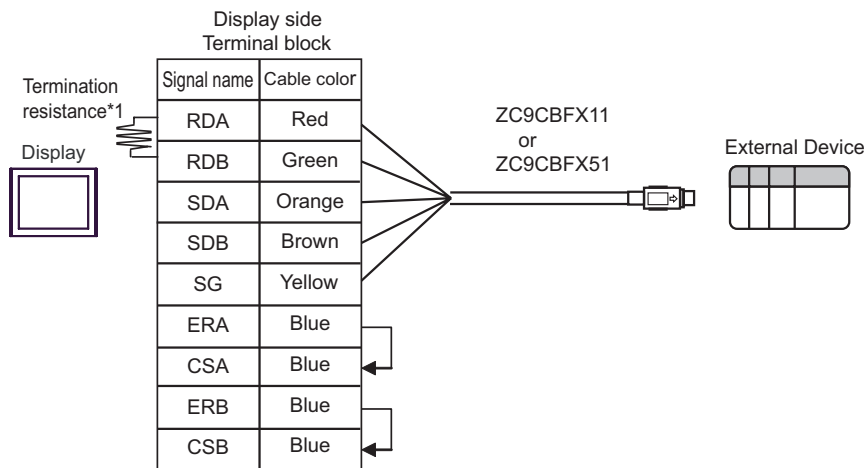

*1 The resistance in the Display is used as the termination resistance. Set the value of the DIP Switch on the rear of the Display as shown in the table below.

DIP Switch No.	Set Value
1	OFF
2	OFF
3	ON
4	OFF

Cable Diagram 3

Display (Connection Port)	Cable		Notes
GP3000 (COM1) GP4000* ¹ (COM1) ST (COM1) IPC* ² PC/AT	3A	RS232C communication cable by Mitsubishi Electric Corp. FX-232CAB-1 (3m) + Function extension board by Mitsubishi Electric Corp.* ³ FX1N-232-BD, FX2N-232-BD, FX3U-232-BD or FX3G-232-BD	The cable length must be 15m or less.
	3B	User-created cable + Function extension board by Mitsubishi Electric Corp.* ³ FX1N-232-BD, FX2N-232-BD, FX3U-232-BD or FX3G-232-BD	
GP-4105 (COM1)	3C	User-created cable + Function extension board by Mitsubishi Electric Corp.* ³ FX1N-232-BD, FX2N-232-BD, FX3U-232-BD or FX3G-232-BD	

*1 All GP4000 models except GP-4100 series and GP-4203T

*2 Only the COM port which can communicate by RS-232C can be used.

☞ ■ IPC COM Port (page 6)

*3 Supported function extension boards vary depending on the model.

CPU	Function Extension Board
FX1S, FX1N	FX1N-232-BD
FX2N	FX2N-232-BD
FX3U, FX3UC	FX3U-232-BD
FX3G	FX3G-232-BD

3A)

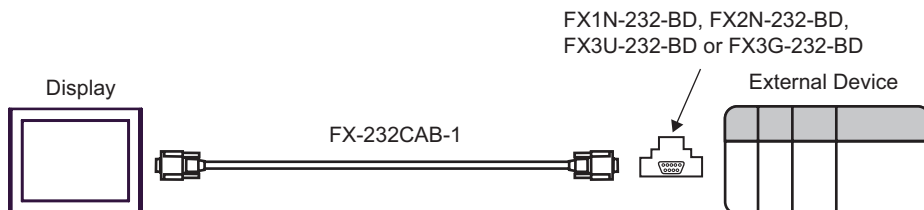

3B)

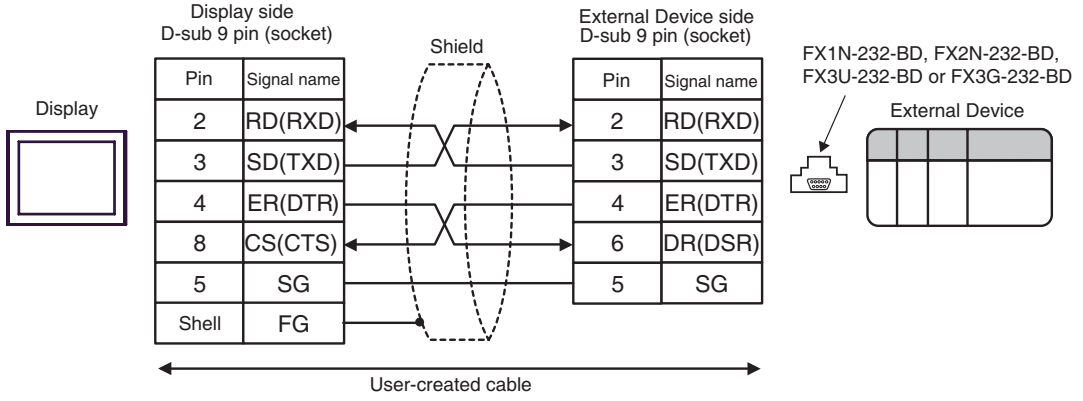

3C)

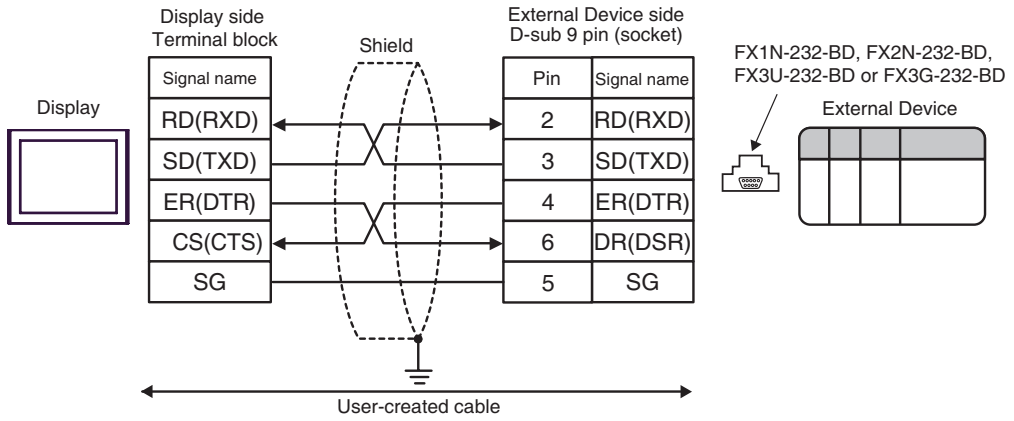

Cable Diagram 4

Display	Cable		Notes
GP3000 (COM1) GP4000* ¹ (COM1) ST (COM1) IPC* ² PC/AT	4A	RS-232C cable by Pro-face CA3-CBL232/5M-01 (5m) + Communication adapter by Mitsubishi Electric Corp. FX0N-232ADP + Function extension board by Mitsubishi Electric Corp.* ³ FX1N-CNV-BD or FX2N-CNV-BD	The cable length must be 15m or less.
	4B	User-created cable + Communication adapter by Mitsubishi Electric Corp. FX0N-232ADP + Function extension board by Mitsubishi Electric Corp.* ³ FX1N-CNV-BD or FX2N-CNV-BD	
4C	User-created cable + Communication adapter by Mitsubishi Electric Corp. FX0N-232ADP + Function extension board by Mitsubishi Electric Corp.* ³ FX1N-CNV-BD or FX2N-CNV-BD		

*1 All GP4000 models except GP-4100 series and GP-4203T

*2 Only the COM port which can communicate by RS-232C can be used.

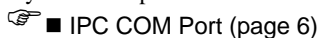

*3 Supported function extension boards vary depending on the model.

CPU	Function Extension Board
FX1S, FX1N	FX1N-CNV-BD
FX2N	FX2N-CNV-BD

4A)

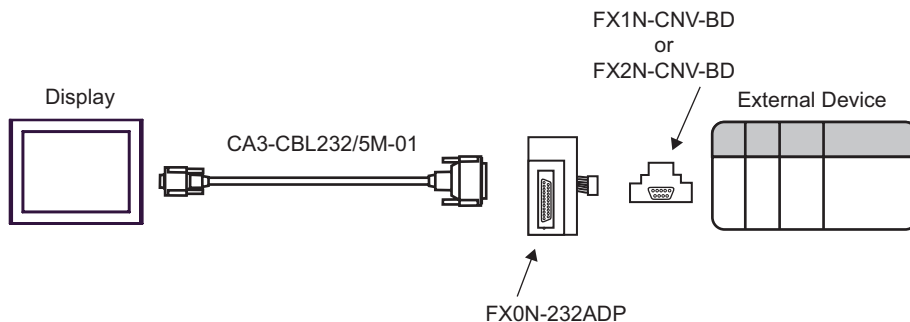

4B)

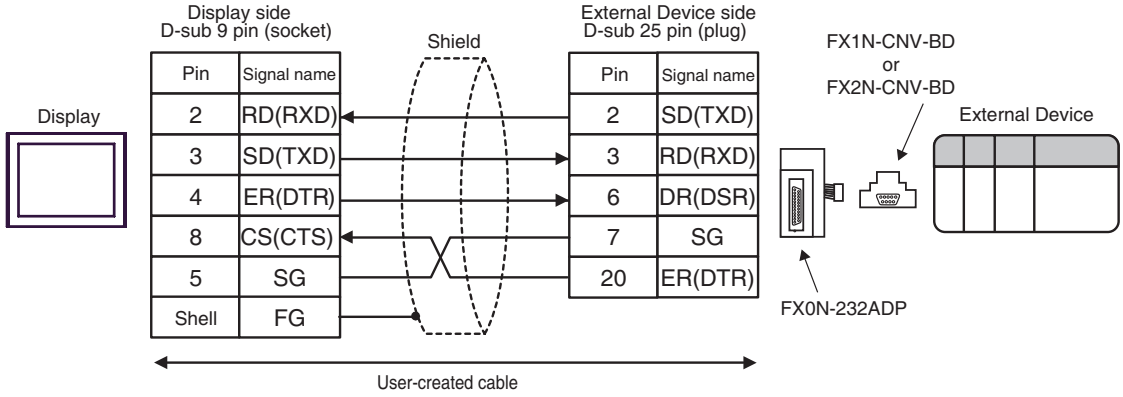

4C)

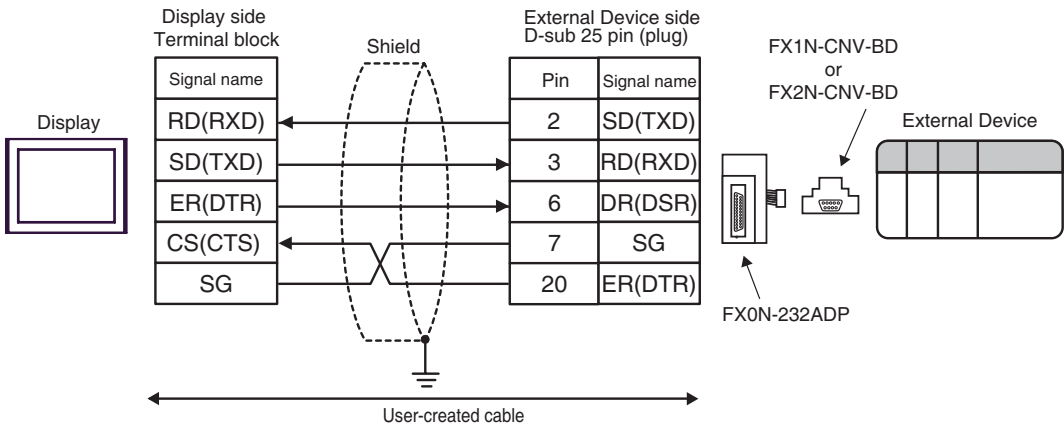

Cable Diagram 5

Display (Connection Port)	Cable		Notes
GP3000 (COM1) GP4000* ¹ (COM1) ST (COM1) IPC* ² PC/AT	5A	RS-232C cable by Pro-face CA3-CBL232/5M-01 (5m) + Communication adapter by Mitsubishi Electric Corp. FX0N-232ADP	The cable length must be 15m or less.
	5B	User-created cable + Communication adapter by Mitsubishi Electric Corp. FX0N-232ADP	
GP-4105 (COM1)	5C	User-created cable + Communication adapter by Mitsubishi Electric Corp. FX0N-232ADP	

*1 All GP4000 models except GP-4100 series and GP-4203T

*2 Only the COM port which can communicate by RS-232C can be used.

☞ ■ IPC COM Port (page 6)

5A)

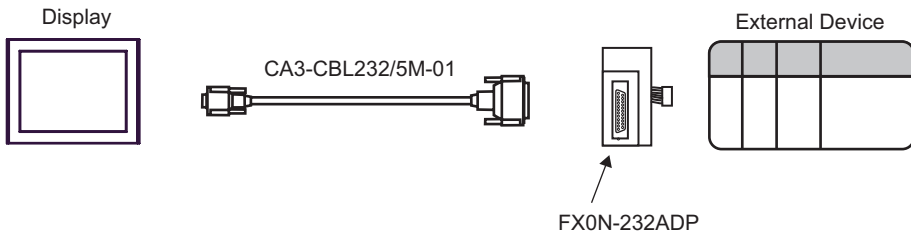

5B)

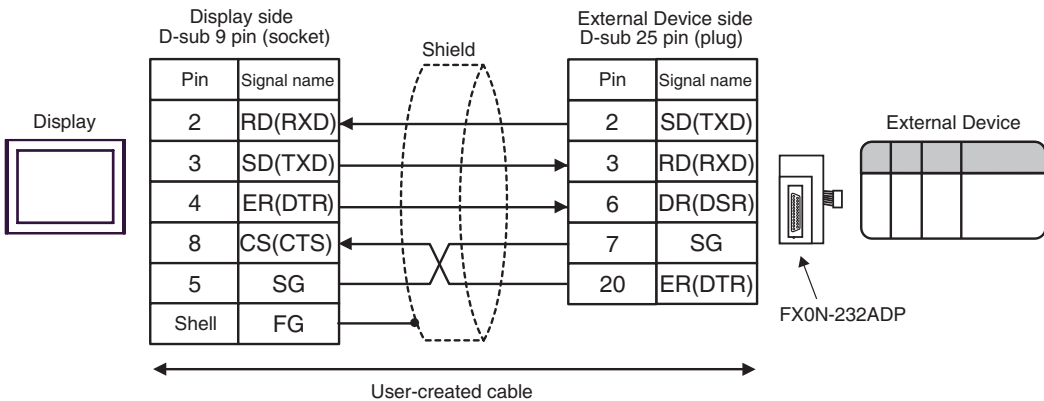

5C)

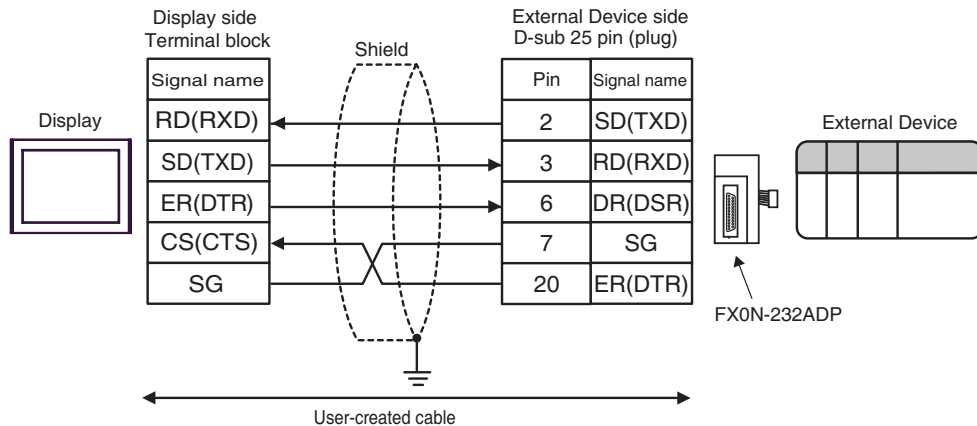

Cable Diagram 6

Display (Connection Port)	Cable		Notes
GP3000 ^{*1} (COM1) AGP-3302B (COM2) GP4000 ^{*2} (COM2) GP-4*01TM (COM1) GP-4201T (COM1) ST ^{*3} (COM2) IPC ^{*4}	6A	Mitsubishi FX connection cable by Pro-face CA3-CBLFX/1M-01 (1m) or CA3-CBLFX/5M-01 (5m) + Function extension board by Mitsubishi Electric Corp. ^{*5} FX1N-422-BD, FX2N-422-BD, FX3U-422-BD or FX3G-422-BD	
GP-4106 (COM1)	6B	Mitsubishi PLC FX Series CPU I/F Cable by Pro-face ZC9CBFX11 (1m) or ZC9CBFX51 (5m) + Function extension board by Mitsubishi Electric Corp. ^{*5} FX1N-422-BD, FX2N-422-BD, FX3U-422-BD or FX3G-422-BD	

*1 All GP3000 models except AGP-3302B

*2 All GP4000 models except GP-4100 series, GP-4*01TM, GP-4201T and GP-4*03T

*3 All ST models except AST-3211A and AST-3302B

*4 Only the COM port which can communicate by RS-422/485 (4 wire) can be used.

 ■ IPC COM Port (page 6)

*5 Supported function extension boards vary depending on the model.

CPU	Function Extension Board
FX1S, FX1N	FX1N-422-BD
FX2N	FX2N-422-BD
FX3U, FX3UC	FX3U-422-BD
FX3G	FX3G-422-BD

6A)

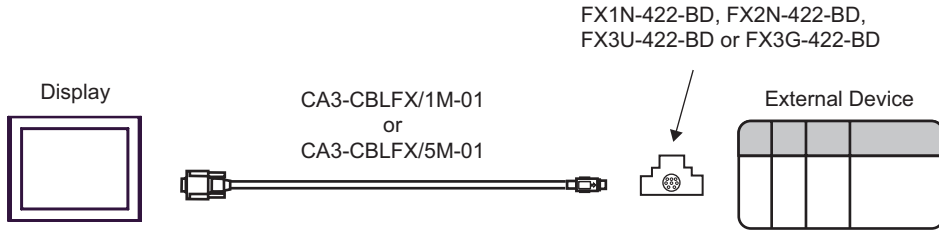

6B)

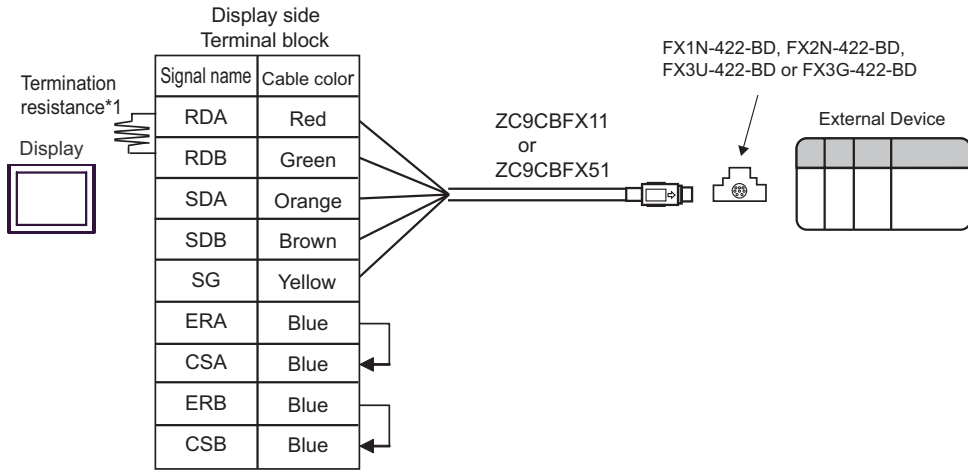

*1 The resistance in the Display is used as the termination resistance. Set the value of the DIP Switch on the rear of the Display as shown in the table below.

DIP Switch No.	Set Value
1	OFF
2	OFF
3	ON
4	OFF

Cable Diagram 7

Display (Connection Port)	Cable		Notes
GP3000 (COM1) GP4000* ¹ (COM1) ST (COM1) IPC* ² PC/AT	7A	RS232C communication cable by Mitsubishi Electric Corp. FX-232CAB-1 (3m) + Communication adapter by Mitsubishi Electric Corp. FX2NC-232ADP + Function extension board by Mitsubishi Electric Corp.* ³ FX1N-CNV-BD or FX2N-CNV-BD	The cable length must be 15m or less.
	7B	User-created cable + Communication adapter by Mitsubishi Electric Corp. FX2NC-232ADP + Function extension board by Mitsubishi Electric Corp.* ³ FX1N-CNV-BD or FX2N-CNV-BD	
GP-4105 (COM1)	7C	User-created cable + Communication adapter by Mitsubishi Electric Corp. FX2NC-232ADP + Function extension board by Mitsubishi Electric Corp.* ³ FX1N-CNV-BD or FX2N-CNV-BD	

*1 All GP4000 models except GP-4100 series and GP-4203T

*2 Only the COM port which can communicate by RS-232C can be used.

 ■ IPC COM Port (page 6)

*3 Supported function extension boards vary depending on the model.

CPU	Function Extension Board
FX1S, FX1N	FX1N-CNV-BD
FX2N	FX2N-CNV-BD

7A)

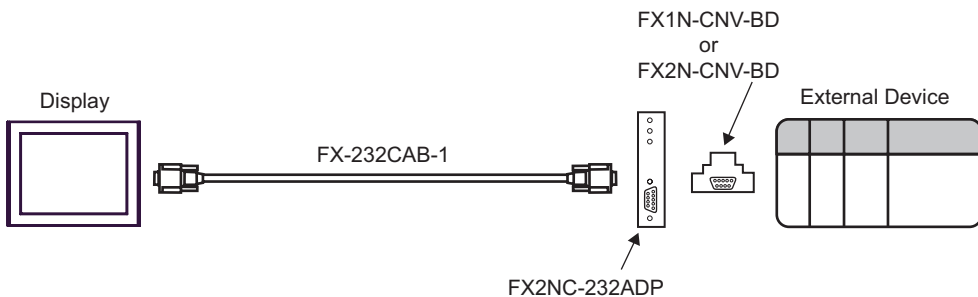

7B)

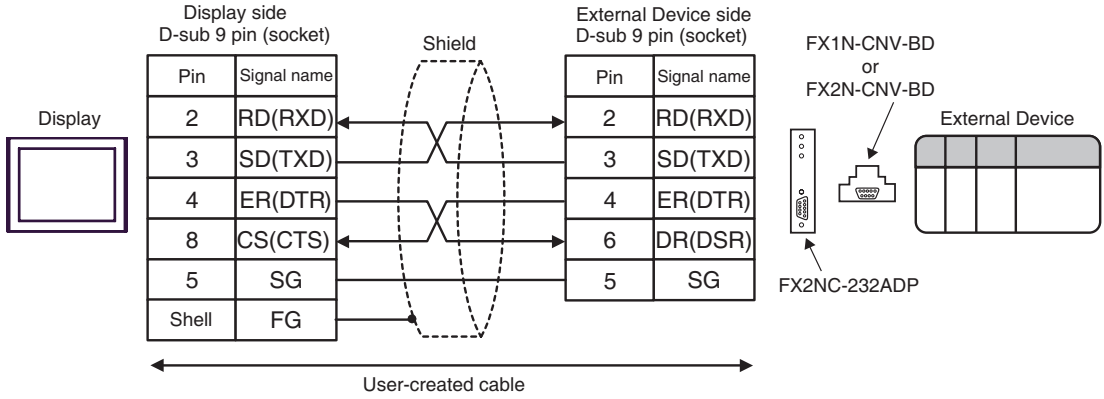

7C)

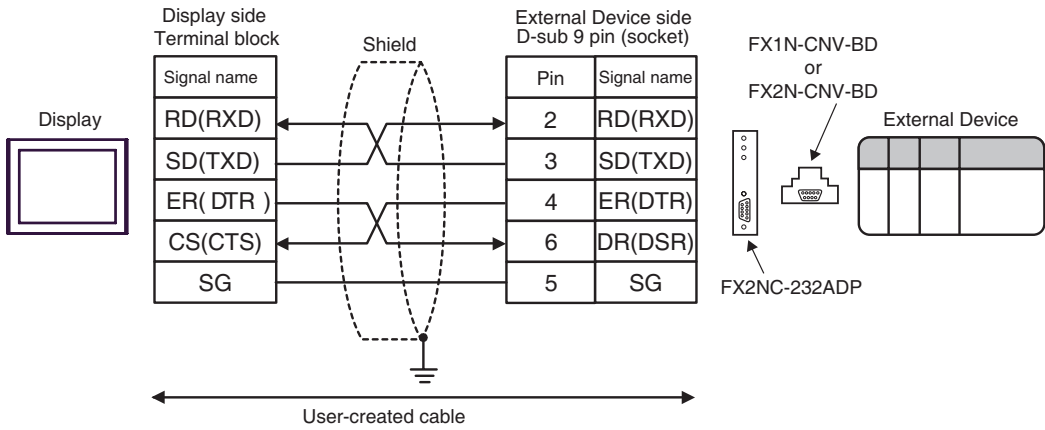

Cable Diagram 8

Display (Connection Port)	Cable		Notes
GP3000 (COM1) GP4000*1 (COM1) ST (COM1) IPC*2 PC/AT	8A	RS232C communication cable by Mitsubishi Electric Corp. FX-232CAB-1 (3m) + Communication adapter by Mitsubishi Electric Corp. FX3U-232ADP + Function extension board by Mitsubishi Electric Corp.*3 FX3U-232-BD, FX3U-422-BD, FX3U-485-BD, FX3U-USB-BD, FX3U-CNV-BD or FX3G-CNV-ADP	The cable length must be 15m or less.
	8B	User-created cable + Communication adapter by Mitsubishi Electric Corp. FX3U-232ADP + Function extension board by Mitsubishi Electric Corp.*3 FX3U-232-BD, FX3U-422-BD, FX3U-485-BD, FX3U-USB-BD, FX3U-CNV-BD or FX3G-CNV-ADP	
GP-4105 (COM1)	8C	User-created cable + Communication adapter by Mitsubishi Electric Corp. FX3U-232ADP + Function extension board by Mitsubishi Electric Corp.*3 FX3U-232-BD, FX3U-422-BD, FX3U-485-BD, FX3U-USB-BD, FX3U-CNV-BD or FX3G-CNV-ADP	

*1 All GP4000 models except GP-4100 series and GP-4203T

*2 Only the COM port which can communicate by RS-232C can be used.

 ■ IPC COM Port (page 6)

*3 Supported function extension boards vary depending on the model.

CPU	Function Extension Board
FX3U, FX3UC	FX3U-232-BD FX3U-422-BD FX3U-485-BD FX3U-USB-BD FX3U-CNV-BD
FX3G	FX3G-CNV-ADP

8A)

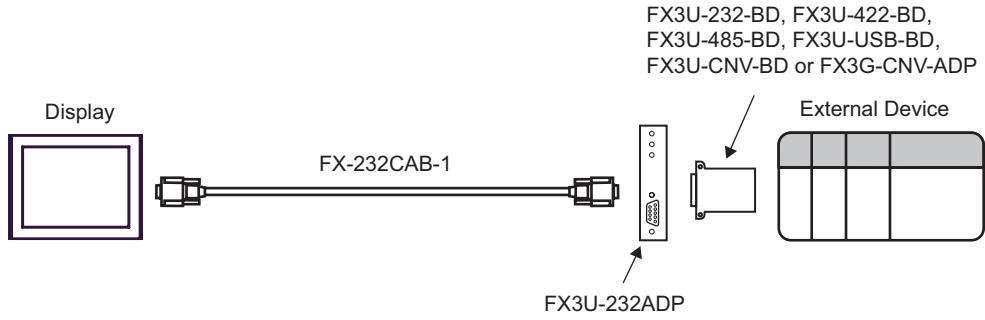

8B)

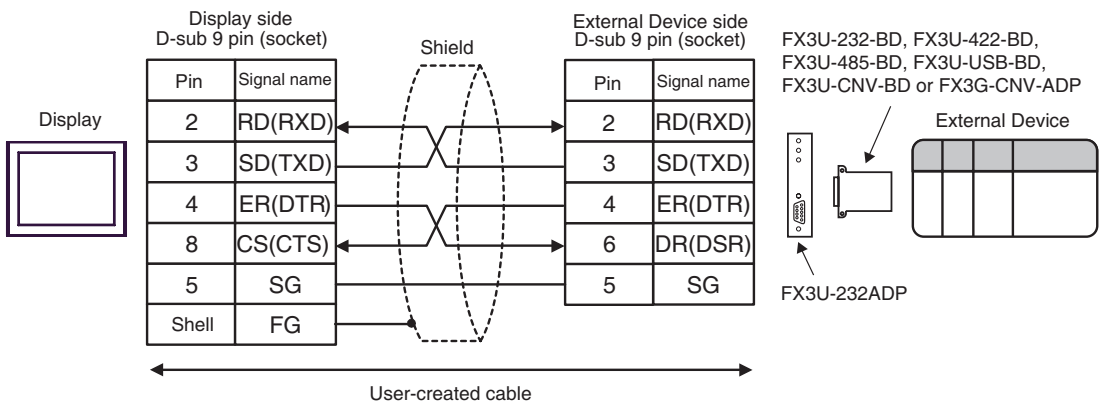

8C)

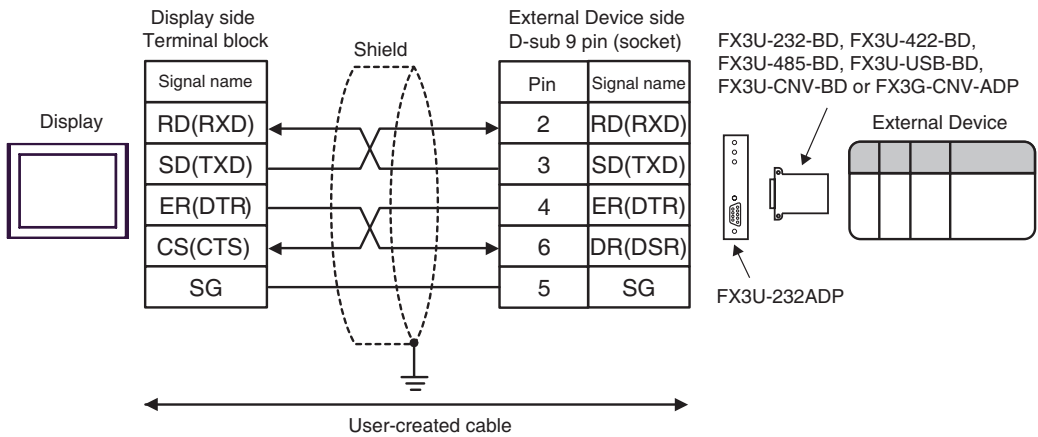

Cable Diagram 9

Display (Connection Port)	Cable		Notes
GP3000 (COM1) GP4000* ¹ (COM1) ST (COM1) IPC* ² PC/AT	9A	RS232C communication cable by Mitsubishi Electric Corp. FX-232CAB-1 (3m) + Communication adapter by Mitsubishi Electric Corp. FX2NC-232ADP	The cable length must be 15m or less.
	9B	User-created cable + Communication adapter by Mitsubishi Electric Corp. FX2NC-232ADP	
GP-4105 (COM1)	9C	User-created cable + Communication adapter by Mitsubishi Electric Corp. FX2NC-232ADP	

*1 All GP4000 models except GP-4100 series and GP-4203T

*2 Only the COM port which can communicate by RS-232C can be used.

☞ ■ IPC COM Port (page 6)

9A)

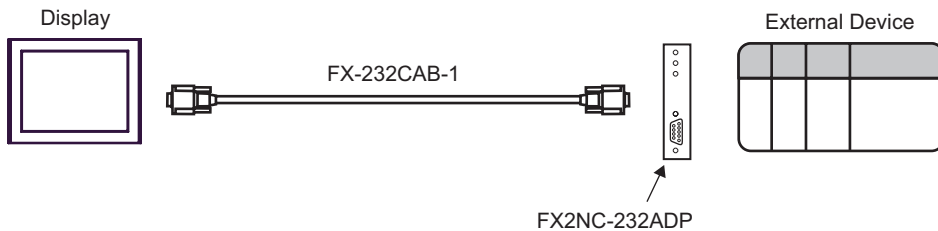

9B)

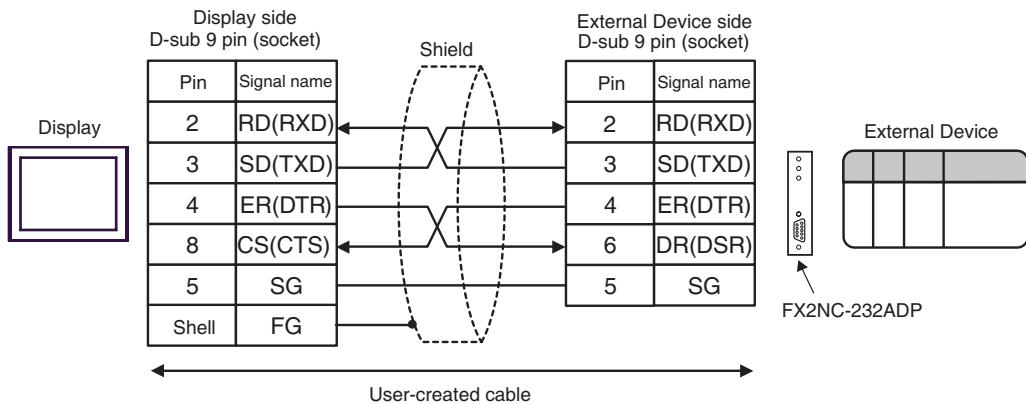

9C)

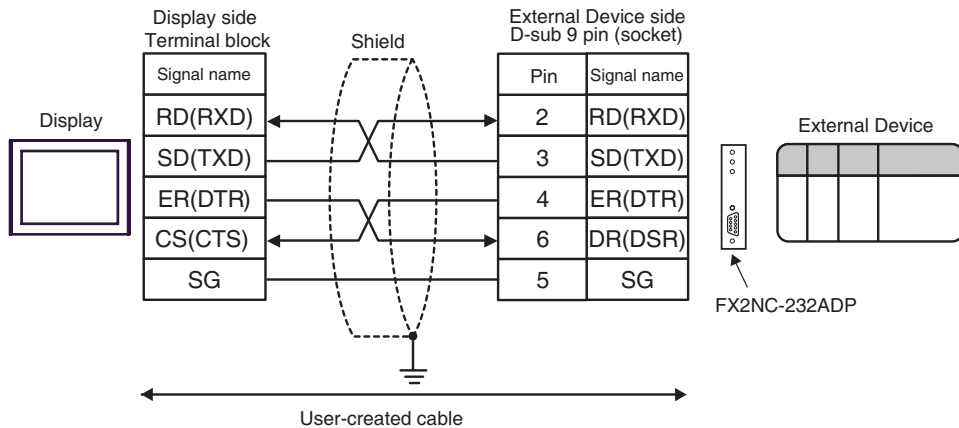

Cable Diagram 10

Display (Connection Port)	Cable		Notes
GP3000* ¹ (COM1) AGP-3302B (COM2) GP-4*01TM (COM1) ST* ² (COM2) IPC* ³	10A	COM port conversion adapter by Pro-face CA3-ADPCOM-01 + 2-port adapter cable for AGP by Pro-face CA3-MDCB11 (5m) + 2-port adapter II by Pro-face GP070-MD11 + Connector conversion cable by Mitsubishi Electric Corp.* ⁴ FX-20P-CADP (0.3m)	The cable length must be 600m or less.
	10B	User-created cable + 2-port adapter II by Pro-face GP070-MD11 + Connector conversion cable by Mitsubishi Electric Corp.* ⁴ FX-20P-CADP (0.3m)	
GP3000* ⁵ (COM2)	10C	Online adapter by Pro-face CA4-ADPONL-01 + 2-port adapter cable for AGP by Pro-face CA3-MDCB11 (5m) + 2-port adapter II by Pro-face GP070-MD11 + Connector conversion cable by Mitsubishi Electric Corp.* ⁴ FX-20P-CADP (0.3m)	
	10D	Online adapter by Pro-face CA4-ADPONL-01 + User-created cable + 2-port adapter II by Pro-face GP070-MD11 + Connector conversion cable by Mitsubishi Electric Corp.* ⁴ FX-20P-CADP (0.3m)	
GP-4106 (COM1)	10E	User-created cable + 2-port adapter II by Pro-face GP070-MD11 + Connector conversion cable by Mitsubishi Electric Corp.* ⁴ FX-20P-CADP (0.3m)	

continued to next page

Display (Connection Port)	Cable		Notes
GP4000* ⁶ (COM2) GP-4201T (COM1)	10F	2-port adapter cable by Pro-face PFXZCBCBMD1* ⁷ + 2-port adapter II by Pro-face GP070-MD11 + Connector conversion cable by Mitsubishi Electric Corp.* ⁴ FX-20P-CADP (0.3m)	The cable length must be 600m or less.
	10B	User-created cable + 2-port adapter II by Pro-face GP070-MD11 + Connector conversion cable by Mitsubishi Electric Corp.* ⁴ FX-20P-CADP (0.3m)	

*1 All GP3000 models except AGP-3302B

*2 All ST models except AST-3211A and AST-3302B

*3 Only the COM port which can communicate by RS-422/485 (4 wire) can be used.

☞ ■ IPC COM Port (page 6)

*4 For FX2, the connector conversion cable (FX-20P-CADP) by Mitsubishi Electric Corp. is not necessary.

*5 All GP3000 models except GP-3200 series and AGP-3302B

*6 All GP4000 models except GP-4100 series, GP-4*01TM, GP-4201T and GP-4*03T

*7 When using a 2-port Adapter Cable (CA3-MDCB11) instead of the 2-port Adapter Cable, refer to Cable Diagram 10A.

10A)

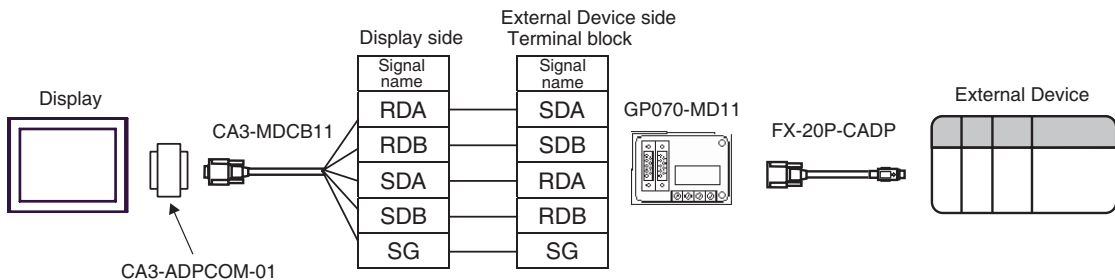

10B)

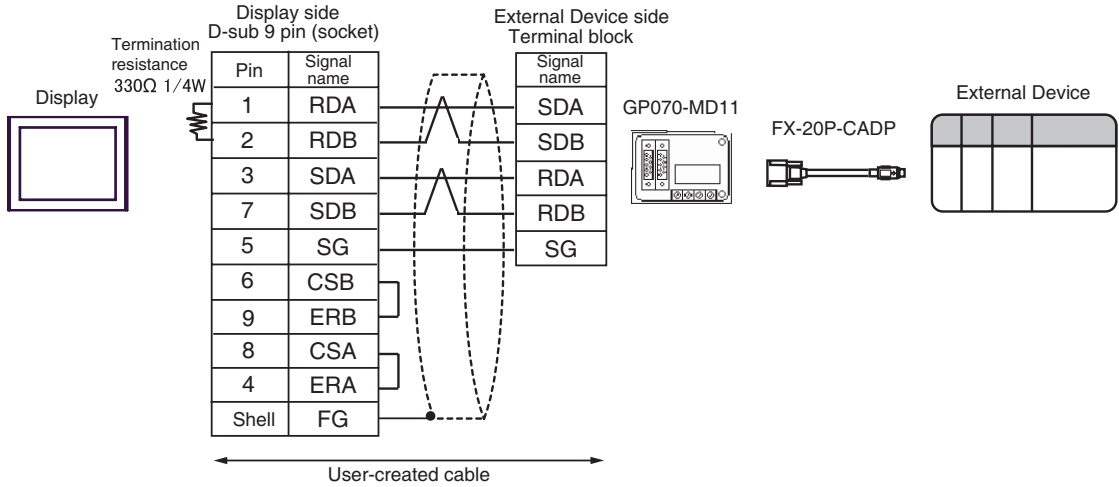

10C)

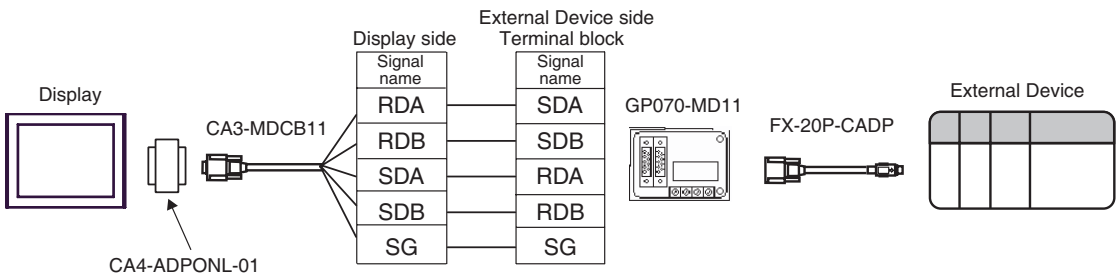

10D)

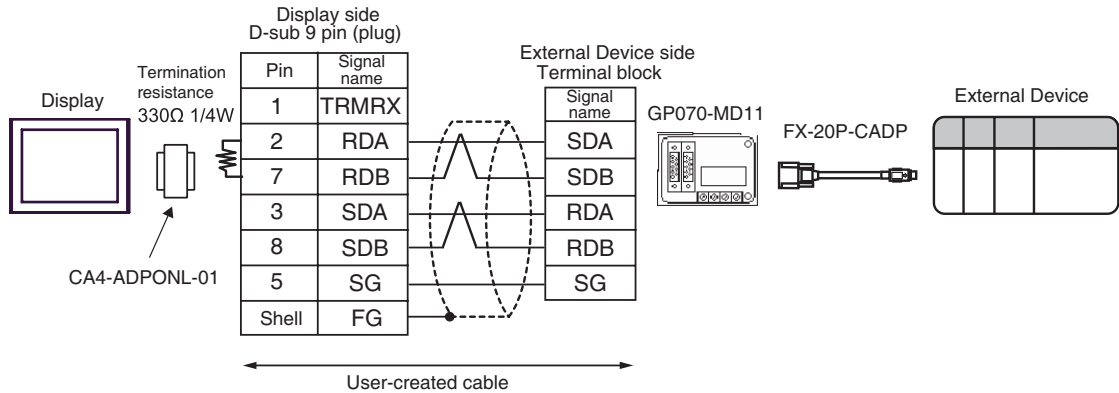

10E)

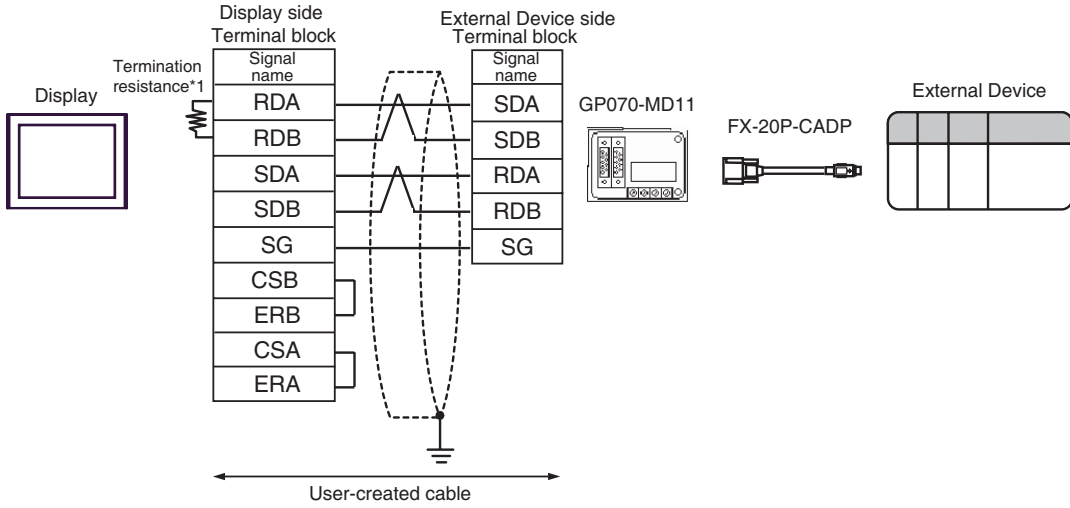

*1 The resistance in the Display is used as the termination resistance. Set the value of the DIP Switch on the rear of the Display as shown in the table below.

DIP Switch No.	Set Value
1	OFF
2	OFF
3	ON
4	OFF

10F)

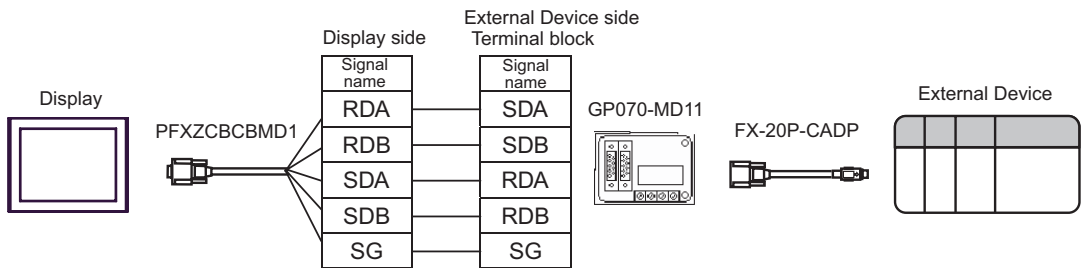

Cable Diagram 11

Display (Connection Port)	Cable		Notes
GP3000* ¹ (COM1) AGP-3302B (COM2) GP-4*01TM (COM1) ST* ² (COM2) IPC* ³	11A	COM port conversion adapter by Pro-face CA3-ADPCOM-01 + 2-port adapter cable for AGP by Pro-face CA3-MDCB11 (5m) + 2-port adapter II by Pro-face GP070-MD11 + Connector conversion cable by Mitsubishi Electric Corp. FX-20P-CADP (0.3m) + Function extension board by Mitsubishi Electric Corp.* ⁴ FX1N-422-BD, FX2N-422-BD, FX3U-422-BD or FX3G-422-BD	
	11B	User-created cable + 2-port adapter II by Pro-face GP070-MD11 + Connector conversion cable by Mitsubishi Electric Corp. FX-20P-CADP (0.3m) + Function extension board by Mitsubishi Electric Corp.* ⁴ FX1N-422-BD, FX2N-422-BD, FX3U-422-BD or FX3G-422-BD	The cable length must be 600m or less.

continued to next page

Display (Connection Port)	Cable		Notes
GP3000* ⁵ (COM2)	11C	Online adapter by Pro-face CA4-ADPONL-01 + 2-port adapter cable for AGP by Pro-face CA3-MDCB11 (5m) + 2-port adapter II by Pro-face GP070-MD11 + Connector conversion cable by Mitsubishi Electric Corp. FX-20P-CADP (0.3m) + Function extension board by Mitsubishi Electric Corp.* ⁴ FX1N-422-BD, FX2N-422-BD, FX3U-422-BD or FX3G-422-BD	
	11D	Online adapter by Pro-face CA4-ADPONL-01 + User-created cable + 2-port adapter II by Pro-face GP070-MD11 + Connector conversion cable by Mitsubishi Electric Corp. FX-20P-CADP (0.3m) + Function extension board by Mitsubishi Electric Corp.* ⁴ FX1N-422-BD, FX2N-422-BD, FX3U-422-BD or FX3G-422-BD	The cable length must be 600m or less.
GP-4106 (COM1)	11E	User-created cable + 2-port adapter II by Pro-face GP070-MD11 + Connector conversion cable by Mitsubishi Electric Corp. FX-20P-CADP (0.3m) + Function extension board by Mitsubishi Electric Corp.* ⁴ FX1N-422-BD, FX2N-422-BD, FX3U-422-BD or FX3G-422-BD	The cable length must be 600m or less.

continued to next page

Display (Connection Port)	Cable		Notes
GP4000* ⁶ (COM2) GP-420IT (COM1)	11F	2-port adapter cable by Pro-face PFXZCBCBMD1* ⁷ + 2-port adapter II by Pro-face GP070-MD11 + Connector conversion cable by Mitsubishi Electric Corp. FX-20P-CADP (0.3m) + Function extension board by Mitsubishi Electric Corp.* ⁴ FX1N-422-BD, FX2N-422-BD, FX3U-422-BD or FX3G-422-BD	
	11B	User-created cable + 2-port adapter II by Pro-face GP070-MD11 + Connector conversion cable by Mitsubishi Electric Corp. FX-20P-CADP (0.3m) + Function extension board by Mitsubishi Electric Corp.* ⁴ FX1N-422-BD, FX2N-422-BD, FX3U-422-BD or FX3G-422-BD	The cable length must be 600m or less.

*1 All GP3000 models except AGP-3302B

*2 All ST models except AST-3211A and AST-3302B

*3 Only the COM port which can communicate by RS-422/485 (4 wire) can be used.

 ■ IPC COM Port (page 6)

*4 Supported function extension boards vary depending on the model.

CPU	Function Extension Board
FX1S, FX1N	FX1N-422-BD
FX2N	FX2N-422-BD
FX3U, FX3UC	FX3U-422-BD
FX3G	FX3G-422-BD

*5 All GP3000 models except GP-3200 series and AGP-3302B

*6 All GP4000 models except GP-4100 series, GP-4*01TM, GP-420IT and GP-4*03T

*7 When using a 2-port Adapter Cable (CA3-MDCB11) instead of the 2-port Adapter Cable, refer to Cable Diagram 11A.

11A)

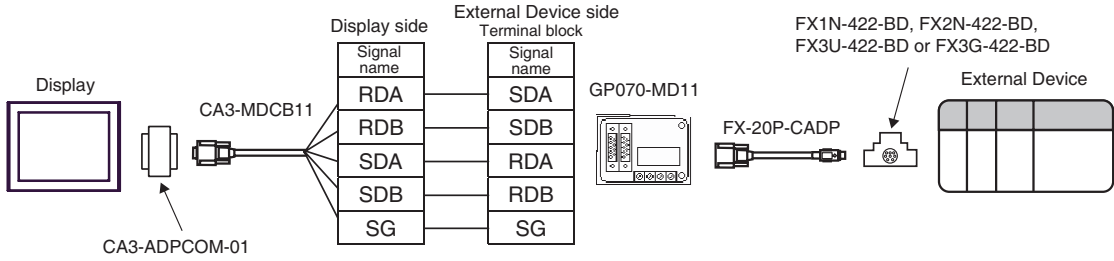

11B)

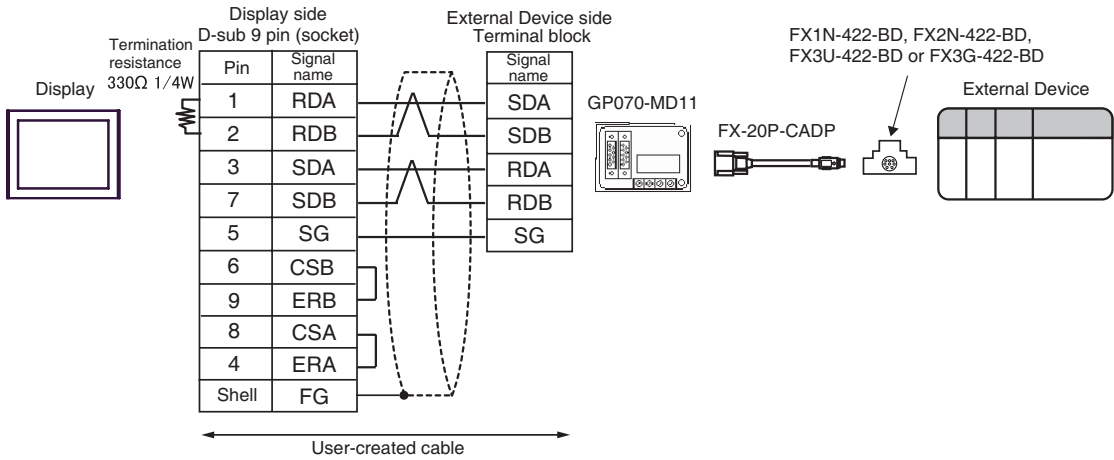

11C)

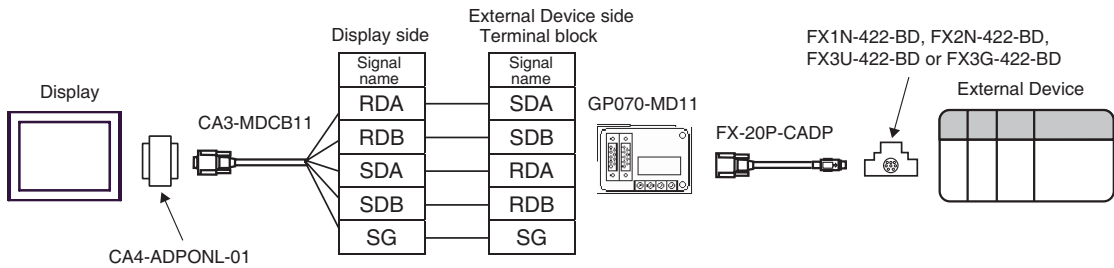

11D)

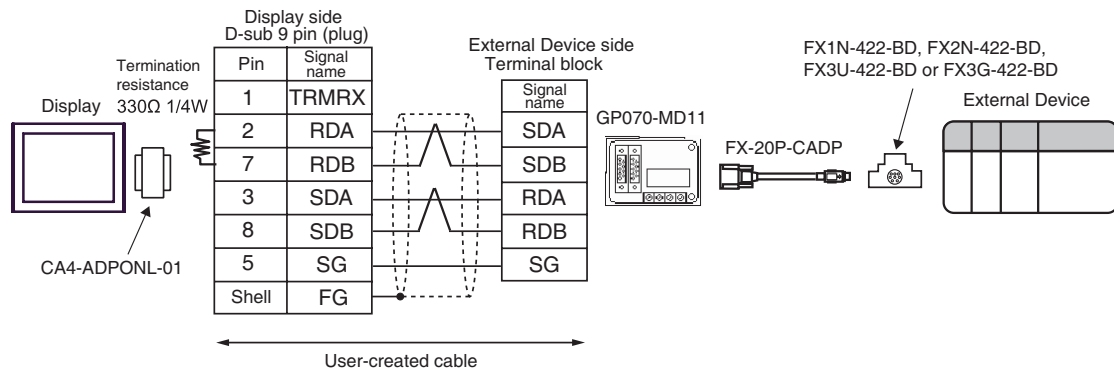

11E)

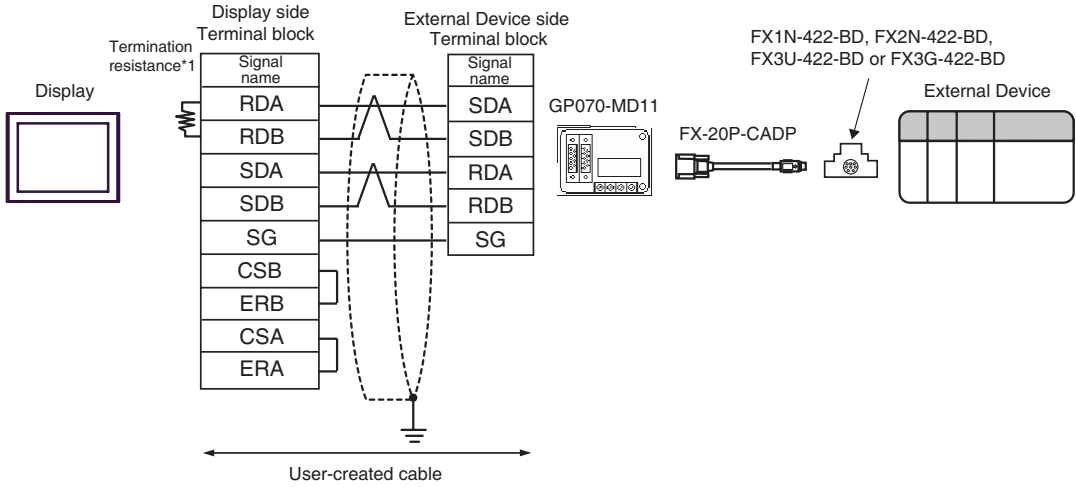

*1 The resistance in the Display is used as the termination resistance. Set the value of the DIP Switch on the rear of the Display as shown in the table below.

DIP Switch No.	Set Value
1	OFF
2	OFF
3	ON
4	OFF

11F)

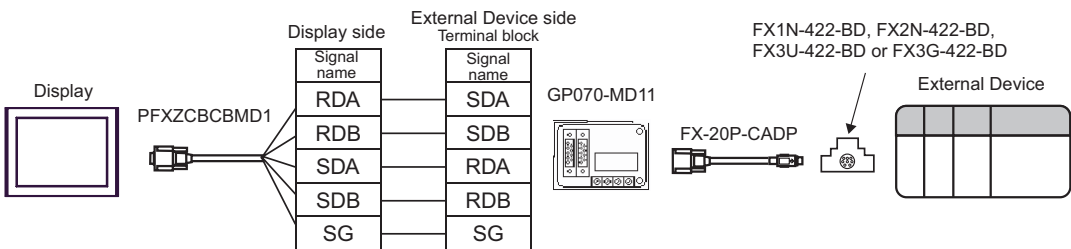







6 Supported Device

Range of supported device address is shown in the table below. Please note that the actually supported range of the devices varies depending on the External Device to be used. Please check the actual range in the manual of your connecting equipment.

6.1 When using FX1

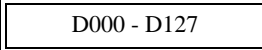
 This address can be specified as system data area.

Device	Bit Address	Word Address	32bits	Notes
Input Relay	X000 - X167	X000 - X160	[L/H]	 *1 *2 *3
Output Relay	Y000 - Y167	Y000 - Y160		 *2
Internal Relay	M0000 - M1023	M0000 - M1008		
Special Auxiliary Relay	M8000 - M8255	M8000 - M8240		 *4
State	S0000 - S0999	S0000 - S0992		
Timer (Contact)	TS000 - TS245	-----		
Counter (Contact)	CS000 - CS135 CS200 - CS255	-----		
Timer (Current Value)	-----	TN000 - TN245		
Counter (Current Value)	-----	CN000 - CN135		
Counter (Current Value)	-----	CN235 - CN255		*5
Data Register	-----	 D000 - D127		
Special Data Register	-----	D8000 - D8069		 *4

*1 Includes an area in which you cannot write.

*2 Specify word address only for the divisible value by 20oct. (Example: X0, X20, X40..., X160)

*3 Writing cannot be made to the address, where Input Terminals are allocated on External Device, from Display.

*4 Special area. This area may be used by the system, and includes an area in which you cannot write. Please refer to the manual attached to the External Device for more detail.

*5 32-bit device.







NOTE

- Please refer to the GP-Pro EX Reference Manual for system data area.
Cf. GP-Pro EX Reference Manual "LS Area (Direct Access Method Area)"
- Please refer to the precautions on manual notation for icons in the table.

 "Manual Symbols and Terminology"

6.2 When using FX2, FX2C

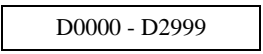
 This address can be specified as system data area.

Device	Bit Address	Word Address	32bits	Notes
Input Relay	X000 - X337	X000 - X320	[L/H]	 *1 *2 *3
Output Relay	Y000 - Y337	Y000 - Y320		 *2
Internal Relay	M0000 - M1535	M0000 - M1520		
Special Auxiliary Relay	M8000 - M8255	M8000 - M8240		 *4
State	S0000 - S0999	S0000 - S0992		
Timer (Contact)	TS000 - TS255	-----		
Counter (Contact)	CS000 - CS255	-----		
Timer (Current Value)	-----	TN000 - TN255		
Counter (Current Value)	-----	CN000 - CN199		
Counter (Current Value)	-----	CN200 - CN255		*5
Data Register	-----	 D0000 - D2999		 *6
Special Data Register	-----	D8000 - D8255		 *4







- *1 Includes an area in which you cannot write.
- *2 Specify word address only for the divisible value by 20oct. (Example: X0, X20, X40..., X320)
- *3 Writing cannot be made to the address, where Input Terminals are allocated on External Device, from Display.
- *4 Special area. This area may be used by the system, and includes an area in which you cannot write. Please refer to the manual attached to the External Device for more detail.
- *5 32-bit device.
- *6 D1000-D2499 is the file register.
To use this area, you need set it as file register. Please refer to the manual attached to the External Device for more detail.

NOTE

- Please refer to the GP-Pro EX Reference Manual for system data area.
Cf. GP-Pro EX Reference Manual "LS Area (DIRECT Access Method Area)"
- Please refer to the precautions on manual notation for icons in the table.
 "Manual Symbols and Terminology"

6.3 When using FX0N

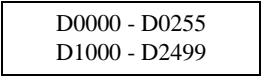
 This address can be specified as system data area.

Device	Bit Address	Word Address	32bits	Notes
Input Relay	X000 - X177	X000 - X160	L/H	 *1 *2 *3
Output Relay	Y000 - Y177	Y000 - Y160		 *2
Internal Relay	M000 - M511	M000 - M496		
Special Auxiliary Relay	M8000 - M8254	M8000 - M8240		 *4
State	S0000 - S0127	S0000 - S0112		
Timer (Contact)	TS000 - TS063	-----		
Counter (Contact)	CS000 - CS031 CS235 - CS254	-----		
Timer (Current Value)	-----	TN000 - TN063		
Counter (Current Value)	-----	CN000 - CN063		
Counter (Current Value)	-----	CN200 - CN254		*5
Data Register	-----	 D0000 - D0255 D1000 - D2499		 *6
Special Data Register	-----	D8000 - D8255		 *4

*1 Includes an area in which you cannot write.

*2 Specify word address only for the divisible value by 20oct. (Example: X0, X20, X40..., X320)

*3 Writing cannot be made to the address, where Input Terminals are allocated on External Device, from Display.

*4 Special area. This area may be used by the system, and includes an area in which you cannot write. Please refer to the manual attached to the External Device for more detail.

*5 32-bit device.

*6 D1000-D2499 is the file register.

To use this area, you need set it as file register. Please refer to the manual attached to the External Device for more detail.







NOTE

- Please refer to the GP-Pro EX Reference Manual for system data area.
Cf. GP-Pro EX Reference Manual "LS Area (DIRECT Access Method Area)"
- Please refer to the precautions on manual notation for icons in the table.

 "Manual Symbols and Terminology"

6.4 When using FX0S

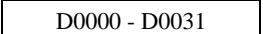
 This address can be specified as system data area.

Device	Bit Address	Word Address	32bits	Notes
Input Relay	X000 - X017	X000 - X000	[L/H]	 *1 *2 *3
Output Relay	Y000 - Y015	Y000 - Y000		 *2
Internal Relay	M000 - M511	M000 - M496		
Special Auxiliary Relay	M8000 - M8254	M8000 - M8240		 *4
State	S000 - S063	S000 - S048		
Timer (Contact)	TS00 - TS55	-----		
Counter (Contact)	CS000 - CS015	-----		
Timer (Current Value)	-----	TN00 - TN55		
Counter (Current Value)	-----	CN000 - CN015		
Data Register	-----	 D0000 - D0031		
Special Data Register	-----	D8000 - D8069		 *4

*1 Includes an area in which you cannot write.

*2 Specify word address only for the divisible value by 20oct. (Example: X0, X20, X40..., X320)

*3 Writing cannot be made to the address, where Input Terminals are allocated on External Device, from Display.







*4 Special area. This area may be used by the system, and includes an area in which you cannot write. Please refer to the manual attached to the External Device for more detail.

NOTE

- Please refer to the GP-Pro EX Reference Manual for system data area.
Cf. GP-Pro EX Reference Manual "LS Area (DIRECT Access Method Area)"
- Please refer to the precautions on manual notation for icons in the table.
 "Manual Symbols and Terminology"

6.5 When using FX1S

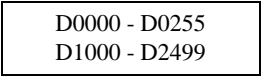
 This address can be specified as system data area.

Device	Bit Address	Word Address	32bits	Notes
Input Relay	X000 - X017	X000 - X000	L/H	 *1 *2 *3
Output Relay	Y000 - Y015	Y000 - Y000		 *2
Internal Relay	M0000 - M0511	M0000 - M0496		
Special Auxiliary Relay	M8000 - M8255	M8000 - M8240		 *4
State	S0000 - S0127	S0000 - S0112		
Timer (Contact)	TS000 - TS063	-----		
Counter (Contact)	CS000 - CS031 CS235 - CS255	-----		
Timer (Current Value)	-----	TN000 - TN063		
Counter (Current Value)	-----	CN000 - CN031		
Counter (Current Value)	-----	CN235 - CN255		*5
Data Register	-----	 D0000 - D0255 D1000 - D2499		 *6
Special Data Register	-----	D8000 - D8255		 *4

*1 Includes an area in which you cannot write.

*2 Specify word address only for the divisible value by 20oct. (Example: X0)

*3 Writing cannot be made to the address, where Input Terminals are allocated on External Device, from Display.

*4 Special area. This area may be used by the system, and includes an area in which you cannot write. Please refer to the manual attached to the External Device for more detail.

*5 32-bit device.

*6 D1000-D2499 is the file register.

To use this area, you need set it as file register. Please refer to the manual attached to the External Device for more detail.







NOTE

- Please refer to the GP-Pro EX Reference Manual for system data area.
Cf. GP-Pro EX Reference Manual "LS Area (Direct Access Method Area)"
- Please refer to the precautions on manual notation for icons in the table.

 "Manual Symbols and Terminology"

6.6 When using FX1N, FX1NC

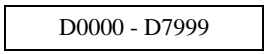
 This address can be specified as system data area.

Device	Bit Address	Word Address	32bits	Notes
Input Relay	X000 - X177	X000 - X160	[L/H]	 *1 *2 *3
Output Relay	Y000 - Y177	Y000 - Y160		 *2
Internal Relay	M0000 - M1535	M0000 - M1520		
Special Auxiliary Relay	M8000 - M8255	M8000 - M8240		 *4
State	S000 - S999	S000 - S992		
Timer (Contact)	TS000 - TS255	-----		
Counter (Contact)	CS000 - CS255	-----		
Timer (Current Value)	-----	TN000 - TN255		
Counter (Current Value)	-----	CN000 - CN199		
Counter (Current Value)	-----	CN200 - CN255		*5
Data Register	-----	 D0000 - D7999		 *6
Special Data Register	-----	D8000 - D8255		 *4

*1 Includes an area in which you cannot write.

*2 Specify word address only for the divisible value by 20oct. (Example: X0, X20, X40..., X160)

*3 Writing cannot be made to the address, where Input Terminals are allocated on External Device, from Display.

*4 Special area. This area may be used by the system, and includes an area in which you cannot write. Please refer to the manual attached to the External Device for more detail.

*5 32-bit device.

*6 You cannot use the data register D7999 as the 32-bit address device. This is because D8000 which is HIGH of the 32-bit device is handled as a different device.







NOTE

- Please refer to the GP-Pro EX Reference Manual for system data area.
Cf. GP-Pro EX Reference Manual "LS Area (Direct Access Method Area)"
- Please refer to the precautions on manual notation for icons in the table.

 "Manual Symbols and Terminology"

6.7 When using FX2N, FX2NC

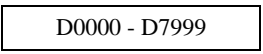
 This address can be specified as system data area.

Device	Bit Address	Word Address	32bits	Notes
Input Relay	X000 - X377	X0000 - X0360	[L/H]	 *1 *2 *3
Output Relay	Y000 - Y377	Y0000 - Y0360		 *2
Internal Relay	M0000 - M3071	M0000 - M3056		
Special Auxiliary Relay	M8000 - M8255	M8000 - M8240		 *4
State	S000 - S999	S000 - S992		
Timer (Contact)	TS000 - TS255	-----		
Counter (Contact)	CS000 - CS255	-----		
Timer (Current Value)	-----	TN000 - TN255		
Counter (Current Value)	-----	CN000 - CN199		
Counter (Current Value)	-----	CN200 - CN255		*5
Data Register	-----	 D0000 - D7999		 *6
Special Data Register	-----	D8000 - D8255		 *4

*1 Includes an area in which you cannot write.

*2 Specify word address only for the divisible value by 20oct. (Example: X0, X20, X40..., X360)

*3 Writing cannot be made to the address, where Input Terminals are allocated on External Device, from Display.

*4 Special area. This area may be used by the system, and includes an area in which you cannot write. Please refer to the manual attached to the External Device for more detail.

*5 32-bit device.

*6 You cannot use the data register D7999 as the 32-bit address device. This is because D8000 which is HIGH of the 32-bit device is handled as a different device.









NOTE

- Please refer to the GP-Pro EX Reference Manual for system data area.
Cf. GP-Pro EX Reference Manual "LS Area (Direct Access Method Area)"
- Please refer to the precautions on manual notation for icons in the table.

 "Manual Symbols and Terminology"

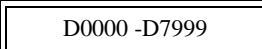
6.8 When using FX3U, FX3UC

 This address can be specified as system data area.

Device	Bit Address	Word Address	32bits	Notes
Input Relay	X000 - X377	X0000 - X0360	L/H	 *1 *2 *3
Output Relay	Y000 - Y377	Y0000 - Y0360		 *2
Internal Relay	M0000 - M7679	M0000 - M7664		
Special Auxiliary Relay	M8000 - M8511	M8000 - M8496		 *4
State	S0000 - S4095	S0000 - S4080		
Timer (Contact)	TS000 - TS511	-----		
Counter (Contact)	CS000 -CS255	-----		
Timer (Current Value)	-----	TN000 - TN511		
Counter (Current Value)	-----	CN000 - CN199		
Counter (Current Value)	-----	CN200 - CN255		*5
Data Register	-----	 D0000 -D7999		 *6
Special Data Register	-----	D8000 - D8511		 *4
Extension Register	-----	R00000 - R32767		 *4









- *1 Includes an area in which you cannot write.
- *2 Specify word address only for the divisible value by 20oct. (Example: X0, X20, X40..., X360)
- *3 Writing cannot be made to the address, where Input Terminals are allocated on External Device, from Display.
- *4 Special area. This area may be used by the system, and includes an area in which you cannot write. Please refer to the manual attached to the External Device for more detail.
- *5 32-bit device.
- *6 You cannot use the data register D7999 as the 32-bit address device. This is because D8000 which is HIGH of the 32-bit device is handled as a different device.

NOTE

- Please refer to the GP-Pro EX Reference Manual for system data area.
Cf. GP-Pro EX Reference Manual "LS Area (Direct Access Method Area)"
- Please refer to the precautions on manual notation for icons in the table.
 "Manual Symbols and Terminology"

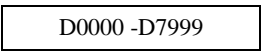
6.9 When using FX3G

 This address can be specified as system data area.

Device	Bit Address	Word Address	32bits	Notes
Input Relay	X000 - X177	X0000 - X0160	L / H	 *1 *2 *3
Output Relay	Y000 - Y177	Y0000 - Y0160		 *2
Internal Relay	M0000 - M7679	M0000 - M7664		
Special Auxiliary Relay	M8000 - M8511	M8000 - M8496		 *4
State	S0000 - S4095	S0000 - S4080		
Timer (Contact)	TS000 - TS319	-----		
Counter (Contact)	CS000 -CS255	-----		
Timer (Current Value)	-----	TN000 - TN319		
Counter (Current Value)	-----	CN000 - CN199		
Counter (Current Value)	-----	CN200 - CN255		*5
Data Register	-----	 D0000 -D7999		 *6
Special Data Register	-----	D8000 - D8511		 *4
Extension Register	-----	R00000 - R23999		 *4

- *1 Includes an area in which you cannot write.
- *2 Specify word address only for the divisible value by 20oct. (Example: X0, X20, X40..., X160)
- *3 Writing cannot be made to the address, where Input Terminals are allocated on External Device, from Display.
- *4 Special area. This area may be used by the system, and includes an area in which you cannot write. Please refer to the manual attached to the External Device for more detail.
- *5 32-bit device.
- *6 You cannot use the data register D7999 as the 32-bit address device. This is because D8000 which is HIGH of the 32-bit device is handled as a different device.

NOTE

- Please refer to the GP-Pro EX Reference Manual for system data area.
Cf. GP-Pro EX Reference Manual "LS Area (Direct Access Method Area)"
- Please refer to the precautions on manual notation for icons in the table.

 "Manual Symbols and Terminology"

7 Device Code and Address Code

Use device code and address code when you select "Device Type & Address" for the address type in data displays.

Device	Device Name	Device Code (HEX)	Address Code
Input Relay	X	0080	Value of word address divided by 0x10
Output Relay	Y	0081	Value of word address divided by 0x10
Internal Relay	M	0082	Value of word address divided by 16
Special Auxiliary Relay	M8	0083	Value of word address divided by 16
State	S	0087	Word Address
Timer (Current Value)	TN	0060	Word Address
Counter (Current Value)	CN	0061	Word Address
Counter (Current Value) *1	CN	0062	Word Address
Data Register	D	0000	Word Address
Special Data Register	D8	0001	Word Address
Extension Register *2	R	000F	Word Address

*1 32-bit device.

*2 Supported only by FX3U, FX3UC and FX3G.

8 Error Messages

Error messages are displayed on the Display screen as follows: "No.: Device Name: Error Message (Error Occurrence Area)". Each description is shown below.

Item	Description
No.	Error No.
Device Name	Name of the External Device where error occurs. Device name is a title of the External Device set with GP-Pro EX. (Initial value [PLC1])
Error Message	Displays messages related to the error which occurs.
Error Occurrence Area	<p>Displays IP address or device address of the External Device where error occurs, or error codes received from the External Device.</p> <p>NOTE</p> <ul style="list-style-type: none"> • IP address is displayed such as "IP address(Decimal): MAC address(Hex)". • Device address is displayed such as "Address: Device address". • Received error codes are displayed such as "Decimal[Hex]".

Display Examples of Error Messages

"RHAA035: PLC1: Error has been responded for device write command (Error Code: 2 [02H])"

-
- NOTE** • Refer to "Display-related errors" in "Maintenance/Troubleshooting Guide" for details on the error messages common to the driver.
-

