



KV-700/1000/3000/5000 CPU Direct

1	System Configuration.....	3
2	External Device Selection	7
3	Communication Settings	8
4	Setup Items	35
5	Cable Diagrams	40
6	Supported Device.....	48
7	Device Code and Address Code.....	54
8	Error Messages	57

Introduction

This manual describes how to connect the Display and the External Device (target PLC).

In this manual, the connection procedure is described in the sections identified below.

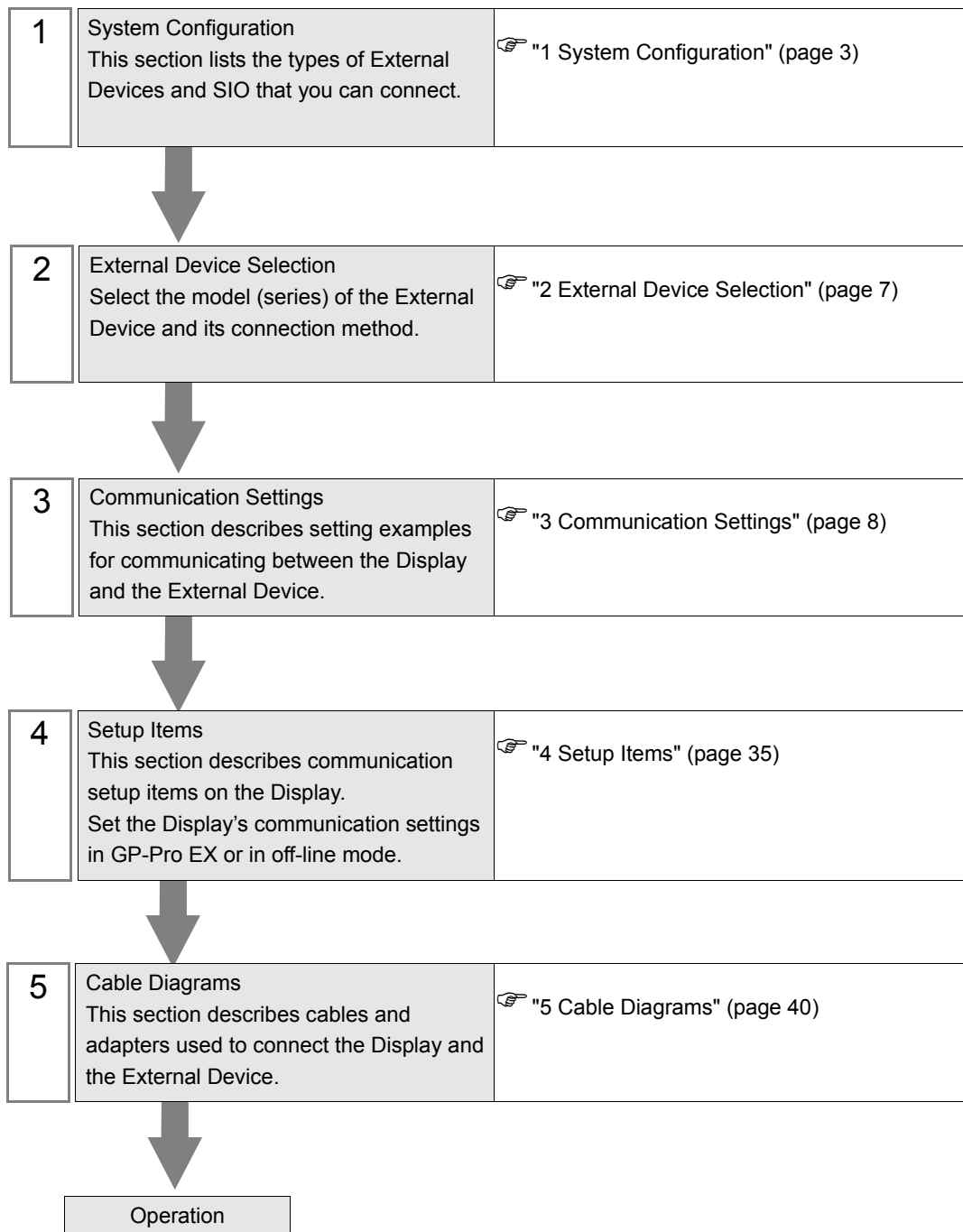

1 System Configuration

The following table lists system configurations for connecting KEYENCE Corporation External Devices and the Display.

Series	CPU	Link I/F	SIO Type	Setting Example	Cable Diagram
KV-700 Series	KV-700	CPU Direct*1	RS-232C	Setting Example 1 (page 8)	Cable Diagram 1 (page 40)
		KV-L20	RS-232C (Port 1 connection)	Setting Example 2 (page 10)	Cable Diagram 2 (page 42)
			RS-232C (Port 2 connection)	Setting Example 4 (page 14)	Cable Diagram 3 (page 43)
			RS-422/485 (4wire) (Port 2 connection)	Setting Example 6 (page 18)	Cable Diagram 4 (page 44)
		KV-L20R	RS-232C (Port 1 connection)	Setting Example 3 (page 12)	Cable Diagram 2 (page 42)
			RS-232C (Port 2 connection)	Setting Example 5 (page 16)	Cable Diagram 3 (page 43)
			RS-422/485 (4wire) (Port 2 connection)	Setting Example 7 (page 20)	Cable Diagram 4 (page 44)
		KV-L20V*2	RS-232C (Port 1 connection)	Setting Example 8 (page 22)	Cable Diagram 2 (page 42)
			RS-232C (Port 2 connection)	Setting Example 9 (page 24)	Cable Diagram 3 (page 43)
			RS-422/485 (4wire) (Port 2 connection)	Setting Example 10 (page 26)	Cable Diagram 4 (page 44)

Series	CPU	Link I/F	SIO Type	Setting Example	Cable Diagram
KV-1000 Series	KV-1000	CPU Direct*1	RS-232C	Setting Example 1 (page 8)	Cable Diagram 1 (page 40)
		KV-L20R	RS-232C (Port 1 connection)	Setting Example 3 (page 12)	Cable Diagram 2 (page 42)
			RS-232C (Port 2 connection)	Setting Example 5 (page 16)	Cable Diagram 3 (page 43)
			RS-422/485 (4wire) (Port 2 connection)	Setting Example 7 (page 20)	Cable Diagram 4 (page 44)
		KV-L20V*2	RS-232C (Port 1 connection)	Setting Example 8 (page 22)	Cable Diagram 2 (page 42)
			RS-232C (Port 2 connection)	Setting Example 9 (page 24)	Cable Diagram 3 (page 43)
			RS-422/485 (4wire) (Port 2 connection)	Setting Example 10 (page 26)	Cable Diagram 4 (page 44)
KV-3000 Series	KV-3000	CPU Direct*1	RS-232C	Setting Example 11 (page 28)	Cable Diagram 1 (page 40)
		KV-L20V*2	RS-232C (Port 1 connection)	Setting Example 12 (page 29)	Cable Diagram 2 (page 42)
			RS-232C (Port 2 connection)	Setting Example 13 (page 31)	Cable Diagram 3 (page 43)
			RS-422/485 (4wire) (Port 2 connection)	Setting Example 14 (page 33)	Cable Diagram 4 (page 44)
KV-5000 Series	KV-5000	KV-L20V*2	RS-232C (Port 1 connection)	Setting Example 12 (page 29)	Cable Diagram 2 (page 42)
			RS-232C (Port 2 connection)	Setting Example 13 (page 31)	Cable Diagram 3 (page 43)
			RS-422/485 (4wire) (Port 2 connection)	Setting Example 14 (page 33)	Cable Diagram 4 (page 44)

*1 Using modular connector on CPU.

*2 For communication settings, KV STUDIO Ver. 4 or later ladder software is required.

■ IPC COM Port

When connecting IPC with an External Device, the COM port used depends on the series and SIO type. Please refer to the IPC manual for details.

Usable port

Series	Usable Port		
	RS-232C	RS-422/485(4 wire)	RS-422/485(2 wire)
PS-2000B	COM1 ^{*1} , COM2, COM3 ^{*1} , COM4	-	-
PS-3450A, PS-3451A, PS3000-BA, PS3001-BD	COM1, COM2 ^{*1*2}	COM2 ^{*1*2}	COM2 ^{*1*2}
PS-3650A, PS-3651A	COM1 ^{*1}	-	-
PS-3700A (Pentium®4-M) PS-3710A	COM1 ^{*1} , COM2 ^{*1} , COM3 ^{*2} , COM4	COM3 ^{*2}	COM3 ^{*2}
PS-3711A	COM1 ^{*1} , COM2 ^{*2}	COM2 ^{*2}	COM2 ^{*2}
PL-3000B, PL-3600T, PL-3600K, PL-3700T, PL-3700K, PL-3900T	COM1 ^{*1*2} , COM2 ^{*1} , COM3, COM4	COM1 ^{*1*2}	COM1 ^{*1*2}

*1 The RI/5V can be switched. Use the IPC's switch to change if necessary.

*2 Set up the SIO type with the DIP switch. Please set up as follows according to SIO type to be used.

DIP switch setting: RS-232C

DIP switch	Setting	Description
1	OFF ^{*1}	Reserved (always OFF)
2	OFF	SIO type: RS-232C
3	OFF	
4	OFF	Output mode of SD (TXD) data: Always output
5	OFF	Terminal resistance (220Ω) insertion to SD (TXD): None
6	OFF	Terminal resistance (220Ω) insertion to RD (RXD): None
7	OFF	Short-circuit of SDA (TXA) and RDA (RXA): Not available
8	OFF	Short-circuit of SDB (TXB) and RDB (RXB): Not available
9	OFF	RS (RTS) Auto control mode: Disabled
10	OFF	

*1 When using PS-3450A, PS-3451A, PS3000-BA and PS3001-BD, turn ON the set value.

DIP switch setting: RS-422/485 (4 wire)

DIP switch	Setting	Description
1	OFF	Reserved (always OFF)
2	ON	SIO type: RS-422/485
3	ON	
4	OFF	Output mode of SD (TXD) data: Always output
5	OFF	Terminal resistance (220Ω) insertion to SD (TXD): None
6	OFF	Terminal resistance (220Ω) insertion to RD (RXD): None
7	OFF	Short-circuit of SDA (TXA) and RDA (RXA): Not available
8	OFF	Short-circuit of SDB (TXB) and RDB (RXB): Not available
9	OFF	RS (RTS) Auto control mode: Disabled
10	OFF	

DIP switch setting: RS-422/485 (2 wire)

DIP switch	Setting	Description
1	OFF	Reserved (always OFF)
2	ON	SIO type: RS-422/485
3	ON	
4	OFF	Output mode of SD (TXD) data: Always output
5	OFF	Terminal resistance (220Ω) insertion to SD (TXD): None
6	OFF	Terminal resistance (220Ω) insertion to RD (RXD): None
7	ON	Short-circuit of SDA (TXA) and RDA (RXA): Available
8	ON	Short-circuit of SDB (TXB) and RDB (RXB): Available
9	ON	RS (RTS) Auto control mode: Enabled
10	ON	

2 External Device Selection

Select the External Device to connect to the Display.

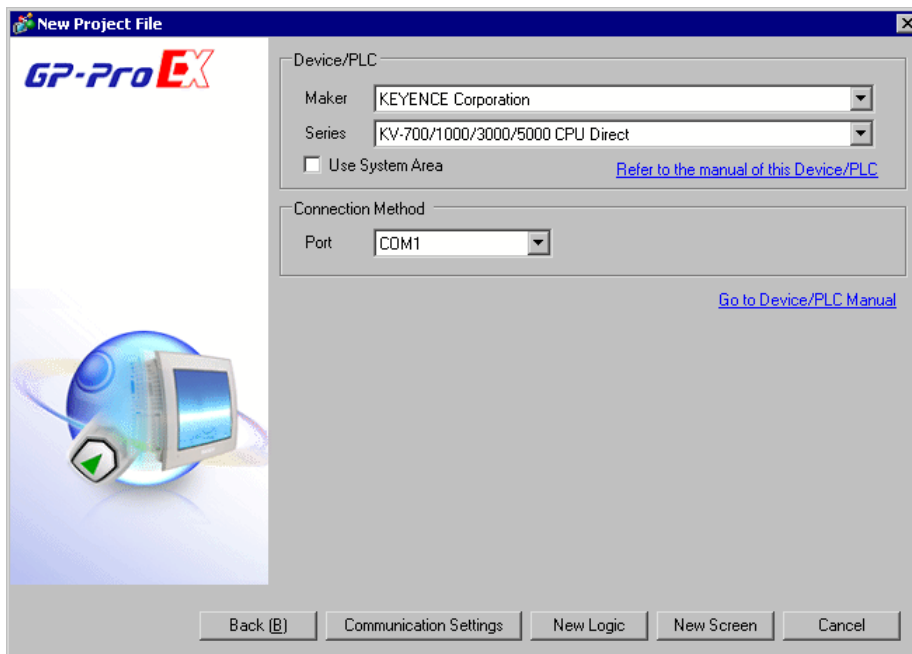

Setup Items	Setup Description
Maker	Select the maker of the External Device to be connected. Select "KEYENCE Corporation".
Series	Select the model (series) of the External Device to be connected and connection method. Select "KV-700/1000/3000/5000 CPU Direct". In the System Configuration, check to make sure the external device you are connecting supported in "KV-700/1000/3000/5000 CPU Direct". ☞ "1 System Configuration" (page 3)
Use System Area	Select this option to synchronize the system data area of the Display and the device (memory) of the External Device. When they are synchronized, you can use the ladder program of the External Device to change screens or to pop up a window on the Display. Cf. GP Pro-EX Reference Manual "Appendix 1.4 LS Area (Direct Access Method)" This can also be set with GP-Pro EX or in the Display off-line mode. Cf. GP Pro-EX Reference Manual " 5.17.6 Setting Guide of [System Setting Window]■[Main Unit Settings] Settings Guide◆System Area Setting" Cf. Maintenance/Troubleshooting "2.15.1 Settings common to all Display models◆System Area Settings"
Port	Select the port of the Display to be connected to the External Device.

3 Communication Settings

This section provides examples of communication settings recommended by Pro-face for the Display and the External Device.

3.1 Setting Example 1

■ GP-Pro EX Settings

◆ Communication Settings

To display the setup screen, from the [System Settings] workspace, select [Device/PLC].

Device/PLC 1

Summary

Maker: KEYENCE Corporation Series: KV-700/1000/3000/5000 CPU Direct Port: COM1

Text Data Mode: 2

Communication Settings

SID Type: RS232C RS422/485(2wire) RS422/485(4wire)

Speed: 19200

Data Length: 7 8

Parity: NONE EVEN ODD

Stop Bit: 1 2

Flow Control: NONE ER(DTR/CTS) XON/XOFF

Timeout: 3 (sec)

Retry: 2

Wait To Send: 0 (ms)

RI / VCC: RI VCC

In the case of RS232C, you can select the 9th pin to RI (Input) or VCC (5V Power Supply). If you use the Digital's RS232C Isolation Unit, please select it to VCC.

Default

Device-Specific Settings

Number	Device Name	Settings
1	PLC1	Series=KV-700/1000

NOTE

- You can set the speed to 9600-57600bps for KV-700 Series, and 9600-115200 bps for KV-1000 Series.

◆ Device Setting

To display the [Individual Device Settings] dialog box, select the external device and click  [Settings] from [Device-Specific Settings] in the [Device/PLC] window.

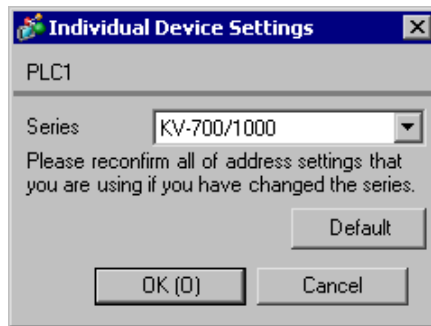

■ External Device Settings

There are no settings on the External Device. The speed automatically switches according to the Display settings.

3.2 Setting Example 2

■ GP-Pro EX Settings

To display the setup screen, from the [System Settings] workspace, select [Device/PLC].

Device/PLC 1

Summary [Change Device/PLC](#)

Maker: KEYENCE Corporation Series: KV-700/1000/3000/5000 CPU Direct Port: COM1

Text Data Mode: 2 [Change](#)

Communication Settings

SID Type: RS232C RS422/485(2wire) RS422/485(4wire)

Speed: 19200

Data Length: 7 8

Parity: NONE EVEN ODD

Stop Bit: 1 2

Flow Control: NONE ER(DTR/CTS) XON/XOFF

Timeout: 3 (sec)

Retry: 2

Wait To Send: 0 (ms)

RI / VCC: RI VCC

In the case of RS232C, you can select the 9th pin to RI (Input) or VCC (5V Power Supply). If you use the Digital's RS232C Isolation Unit, please select it to VCC.

Default

Device-Specific Settings

Allowable Number of Devices/PLCs: 1

Number	Device Name	Settings
1	PLC1	Series=KV-700/1000

◆ Device Setting

To display the [Individual Device Settings] dialog box, select the external device and click  [Settings] from [Device-Specific Settings] in the [Device/PLC] window.

Individual Device Settings

PLC1

Series: KV-700/1000

Please reconfirm all of address settings that you are using if you have changed the series.

Default

OK (O) Cancel

■ External Device Settings

Use the KEYENCE Corporation ladder software (KV STUDIO Ver. 4 or later) to configure communication settings for the External Device.

Refer to your External Device manual for details.

- (1) Start up the ladder software.
- (2) From the [File] menu, select [New Project] and display the [New Project] dialog box.
- (3) Type a project name in [Project Name], select the External Device to use under [PLC model], and click [OK].
- (4) Click [Yes] in the [Confirm unit setting information] dialog box and display the [Unit Editor] window.
- (5) Select "KV-L20" from the displayed unit list on the [Select unit] tab, and drag & drop it to the unit placement area.
- (6) Double-click "KV-L20" in the unit placement area.
- (7) Configure the following communication settings on the [Setup unit] tab.

	Setup Items	Setup Description
Port 1	Operation Mode	KV BUILDER mode
	Interface	RS-232C
	Baud Rate	Auto
	Data Bit Length	8 bits
	Start Bit	1 bit
	Stop Bit	1 bit
	Parity	Even
	Check Sum	None
	RS/CS Flow Control	Disabled

- (8) From the [Convert] menu, select [Auto-assign relay/DM].
- (9) From the [File] menu, select [Close] and display the [Unit Editor] dialog box.
- (10) Click [Yes].
- (11) From the [Monitor/Simulator] menu, select [Transfer to PLC] to display the [Transfer Program] dialog box.
- (12) Check [Unit setting info] and [Program], and then click [Execute]. The setting information is transferred.

This completes the setting of the External Device.

3.3 Setting Example 3

■ GP-Pro EX Settings

To display the setup screen, from the [System Settings] workspace, select [Device/PLC].

Device/PLC 1

Summary [Change Device/PLC](#)

Maker Series Port

Text Data Mode [Change](#)

Communication Settings

SID Type RS232C RS422/485(2wire) RS422/485(4wire)

Speed

Data Length 7 8

Parity NONE EVEN ODD

Stop Bit 1 2

Flow Control NONE ER(DTR/CTS) XON/XOFF

Timeout (sec)

Retry

Wait To Send (ms)

RI / VCC RI VCC

In the case of RS232C, you can select the 9th pin to RI (Input) or VCC (5V Power Supply). If you use the Digital's RS232C Isolation Unit, please select it to VCC.

Device-Specific Settings

Allowable Number of Devices/PLCs

Number	Device Name	Settings
<input type="button" value="1"/>	<input type="text" value="PLC1"/>	<input type="text" value="Series=KV-700/1000"/>

◆ Device Setting

To display the [Individual Device Settings] dialog box, select the external device and click  [Settings] from [Device-Specific Settings] in the [Device/PLC] window.

Individual Device Settings

PLC1

Series

Please reconfirm all of address settings that you are using if you have changed the series.

■ External Device Settings

Use the KEYENCE Corporation ladder software (KV STUDIO Ver. 4 or later) to configure communication settings for the External Device.

Refer to your External Device manual for details.

- (1) Start up the ladder software.
- (2) From the [File] menu, select [New Project] and display the [New Project] dialog box.
- (3) Type a project name in [Project Name], select the External Device to use under [PLC model], and click [OK].
- (4) Click [Yes] in the [Confirm unit setting information] dialog box and display the [Unit Editor] window.
- (5) Select "KV-L20R" from the displayed unit list on the [Select unit] tab, and drag & drop it to the unit placement area.
- (6) Double-click "KV-L20R" in the unit placement area.
- (7) Configure the following communication settings on the [Setup unit] tab.

Setup Items		Setup Description
Port 1	Operation Mode	KV BUILDER/KV STUDIO mode
	Interface	RS-232C
	Baud Rate	Auto
	Data Bit Length	8 bits
	Start Bit	1 bit
	Stop Bit	1 bit
	Parity	Even
	Check Sum	None
	RS/CS Flow Control	Disabled
Station No.	Station No.	0
Detail Settings	Transfer Timeout (sec.)	3

- (8) From the [Convert] menu, select [Auto-assign relay/DM].
- (9) From the [File] menu, select [Close] and display the [Unit Editor] dialog box.
- (10) Click [Yes].
- (11) From the [Monitor/Simulator] menu, select [Transfer to PLC] to display the [Transfer Program] dialog box.
- (12) Check [Unit setting info] and [Program], and then click [Execute]. The setting information is transferred.

This completes the setting of the External Device.

3.4 Setting Example 4

■ GP-Pro EX Settings

To display the setup screen, from the [System Settings] workspace, select [Device/PLC].

Device/PLC 1

Summary [Change Device/PLC](#)

Maker Series Port

Text Data Mode [Change](#)

Communication Settings

SID Type RS232C RS422/485(2wire) RS422/485(4wire)

Speed

Data Length 7 8

Parity NONE EVEN ODD

Stop Bit 1 2

Flow Control NONE ER(DTR/CTS) XON/XOFF

Timeout (sec)

Retry

Wait To Send (ms)

RI / VCC RI VCC

In the case of RS232C, you can select the 9th pin to RI (Input) or VCC (5V Power Supply). If you use the Digital's RS232C Isolation Unit, please select it to VCC.

Device-Specific Settings

Allowable Number of Devices/PLCs

Number	Device Name	Settings
<input type="button" value="1"/>	<input type="text" value="PLC1"/>	<input type="text" value="Series=KV-700/1000"/>

◆ Device Setting

To display the [Individual Device Settings] dialog box, select the external device and click  [Settings] from [Device-Specific Settings] in the [Device/PLC] window.

Individual Device Settings

PLC1

Series

Please reconfirm all of address settings that you are using if you have changed the series.

■ External Device Settings

Use the KEYENCE Corporation ladder software (KV STUDIO Ver. 4 or later) to configure communication settings for the External Device.

Refer to your External Device manual for details.

- (1) Start up the ladder software.
- (2) From the [File] menu, select [New Project] and display the [New Project] dialog box.
- (3) Type a project name in [Project Name], select the External Device to use under [PLC model], and click [OK].
- (4) Click [Yes] in the [Confirm unit setting information] dialog box and display the [Unit Editor] window.
- (5) Select "KV-L20" from the displayed unit list on the [Select unit] tab, and drag & drop it to the unit placement area.
- (6) Double-click "KV-L20" in the unit placement area.
- (7) Configure the following communication settings on the [Setup unit] tab.

Setup Items		Setup Description
Port 2	Operation Mode	KV BUILDER mode
	Interface	RS-232C
	Station No.	0
	Baud Rate	Auto
	Data Bit Length	8 bits
	Start Bit	1 bit
	Stop Bit	1 bit
	Parity	Even
	Check Sum	None

- (8) From the [Convert] menu, select [Auto-assign relay/DM].
- (9) From the [File] menu, select [Close] and display the [Unit Editor] dialog box.
- (10) Click [Yes].
- (11) From the [Monitor/Simulator] menu, select [Transfer to PLC] to display the [Transfer Program] dialog box.
- (12) Check [Unit setting info] and [Program], and then click [Execute]. The setting information is transferred.

This completes the setting of the External Device.

3.5 Setting Example 5

■ GP-Pro EX Settings

To display the setup screen, from the [System Settings] workspace, select [Device/PLC].

Device/PLC 1

Summary [Change Device/PLC](#)

Maker Series Port

Text Data Mode [Change](#)

Communication Settings

SID Type RS232C RS422/485(2wire) RS422/485(4wire)

Speed

Data Length 7 8

Parity NONE EVEN ODD

Stop Bit 1 2

Flow Control NONE ER(DTR/CTS) XON/XOFF

Timeout (sec)

Retry

Wait To Send (ms)

RI / VCC RI VCC

In the case of RS232C, you can select the 9th pin to RI (Input) or VCC (5V Power Supply). If you use the Digital's RS232C Isolation Unit, please select it to VCC.

[Default](#)

Device-Specific Settings

Allowable Number of Devices/PLCs [Settings](#)

Number	Device Name	Series
<input type="text" value="1"/>	<input type="text" value="PLC1"/>	<input type="text" value="Series=KV-700/1000"/>

◆ Device Setting

To display the [Individual Device Settings] dialog box, select the external device and click  [Settings] from [Device-Specific Settings] in the [Device/PLC] window.

Individual Device Settings

PLC1

Series

Please reconfirm all of address settings that you are using if you have changed the series.

[Default](#)

[OK \(O\)](#) [Cancel](#)

■ External Device Settings

Use the KEYENCE Corporation ladder software (KV STUDIO Ver. 4 or later) to configure communication settings for the External Device.

Refer to your External Device manual for details.

- (1) Start up the ladder software.
- (2) From the [File] menu, select [New Project] and display the [New Project] dialog box.
- (3) Type a project name in [Project Name], select the External Device to use under [PLC model], and click [OK].
- (4) Click [Yes] in the [Confirm unit setting information] dialog box and display the [Unit Editor] window.
- (5) Select "KV-L20R" from the displayed unit list on the [Select unit] tab, and drag & drop it to the unit placement area.
- (6) Double-click "KV-L20R" in the unit placement area.
- (7) Configure the following communication settings on the [Setup unit] tab.

Setup Items		Setup Description
Port 2	Operation Mode	KV BUILDER/KV STUDIO mode
	Interface	RS-232C
	Baud Rate	Auto
	Data Bit Length	8 bits
	Start Bit	1 bit
	Stop Bit	1 bit
	Parity	Even
	Check Sum	None
Station No.	Station No.	0
Detail Settings	Transfer Timeout (sec.)	3

- (8) From the [Convert] menu, select [Auto-assign relay/DM].
- (9) From the [File] menu, select [Close] and display the [Unit Editor] dialog box.
- (10) Click [Yes].
- (11) From the [Monitor/Simulator] menu, select [Transfer to PLC] to display the [Transfer Program] dialog box.
- (12) Check [Unit setting info] and [Program], and then click [Execute]. The setting information is transferred.

This completes the setting of the External Device.

3.6 Setting Example 6

■ GP-Pro EX Settings

To display the setup screen, from the [System Settings] workspace, select [Device/PLC].

Device/PLC 1

Summary [Change Device/PLC](#)

Maker Series Port

Text Data Mode [Change](#)

Communication Settings

RS232C RS422/485(2wire) RS422/485(4wire)

Speed

Data Length 7 8

Parity NONE EVEN ODD

Stop Bit 1 2

Flow Control NONE ER(DTR/CTS) XON/XOFF

Timeout (sec)

Retry

Wait To Send (ms)

RI / VCC RI VCC

In the case of RS232C, you can select the 9th pin to RI (Input) or VCC (5V Power Supply). If you use the Digital's RS232C Isolation Unit, please select it to VCC.

Device-Specific Settings

Allowable Number of Devices/PLCs

Number	Device Name	Settings
<input type="button" value="1"/>	<input type="text" value="PLC1"/>	<input type="button" value="Series=KV-700/1000"/>

◆ Device Setting

To display the [Individual Device Settings] dialog box, select the external device and click  [Settings] from [Device-Specific Settings] in the [Device/PLC] window.

Individual Device Settings

PLC1

Series

Please reconfirm all of address settings that you are using if you have changed the series.

■ External Device Settings

Use the KEYENCE Corporation ladder software (KV STUDIO Ver. 4 or later) to configure communication settings for the External Device.

Refer to your External Device manual for details.

- (1) Start up the ladder software.
- (2) From the [File] menu, select [New Project] and display the [New Project] dialog box.
- (3) Type a project name in [Project Name], select the External Device to use under [PLC model], and click [OK].
- (4) Click [Yes] in the [Confirm unit setting information] dialog box and display the [Unit Editor] window.
- (5) Select "KV-L20" from the displayed unit list on the [Select unit] tab, and drag & drop it to the unit placement area.
- (6) Double-click "KV-L20" in the unit placement area.
- (7) Configure the following communication settings on the [Setup unit] tab.

Setup Items		Setup Description
Port 2	Operation Mode	KV BUILDER mode
	Interface	RS-422A
	Station No.	0
	Baud Rate	Auto
	Data Bit Length	8 bits
	Start Bit	1 bit
	Stop Bit	1 bit
	Parity	Even
	Check Sum	None

- (8) From the [Convert] menu, select [Auto-assign relay/DM].
- (9) From the [File] menu, select [Close] and display the [Unit Editor] dialog box.
- (10) Click [Yes].
- (11) From the [Monitor/Simulator] menu, select [Transfer to PLC] to display the [Transfer Program] dialog box.
- (12) Check [Unit setting info] and [Program], and then click [Execute]. The setting information is transferred.

This completes the setting of the External Device.

3.7 Setting Example 7

■ GP-Pro EX Settings

To display the setup screen, from the [System Settings] workspace, select [Device/PLC].

Device/PLC 1

Summary [Change Device/PLC](#)

Maker: KEYENCE Corporation Series: KV-700/1000/3000/5000 CPU Direct Port: COM1

Text Data Mode: 2 [Change](#)

Communication Settings

SI0 Type: RS232C RS422/485(2wire) RS422/485(4wire)

Speed: 19200

Data Length: 7 8

Parity: NONE EVEN ODD

Stop Bit: 1 2

Flow Control: NONE ER(DTR/CTS) XON/XOFF

Timeout: 3 (sec)

Retry: 2

Wait To Send: 0 (ms)

RI / VCC RI VCC

In the case of RS232C, you can select the 9th pin to RI (Input) or VCC (5V Power Supply). If you use the Digital's RS232C Isolation Unit, please select it to VCC.

Default

Device-Specific Settings

Allowable Number of Devices/PLCs: 1

Number	Device Name	Settings
1	PLC1	Series=KV-700/1000

◆ Device Setting

To display the [Individual Device Settings] dialog box, select the external device and click  [Settings] from [Device-Specific Settings] in the [Device/PLC] window.

Individual Device Settings

PLC1

Series: KV-700/1000

Please reconfirm all of address settings that you are using if you have changed the series.

Default

OK (O) Cancel

■ External Device Settings

Use the KEYENCE Corporation ladder software (KV STUDIO Ver. 4 or later) to configure communication settings for the External Device.

Refer to your External Device manual for details.

- (1) Start up the ladder software.
- (2) From the [File] menu, select [New Project] and display the [New Project] dialog box.
- (3) Type a project name in [Project Name], select the External Device to use under [PLC model], and click [OK].
- (4) Click [Yes] in the [Confirm unit setting information] dialog box and display the [Unit Editor] window.
- (5) Select "KV-L20R" from the displayed unit list on the [Select unit] tab, and drag & drop it to the unit placement area.
- (6) Double-click "KV-L20R" in the unit placement area.
- (7) Configure the following communication settings on the [Setup unit] tab.

Setup Items		Setup Description
Port 2	Operation Mode	KV BUILDER/KV STUDIO mode
	Interface	RS-422A/485 (4wire)
	Baud Rate	Auto
	Data Bit Length	8 bits
	Start Bit	1 bit
	Stop Bit	1 bit
	Parity	Even
	Check Sum	None
Station No.	Station No.	0
Detail Settings	Transfer Timeout (sec.)	3

- (8) From the [Convert] menu, select [Auto-assign relay/DM].
- (9) From the [File] menu, select [Close] and display the [Unit Editor] dialog box.
- (10) Click [Yes].
- (11) From the [Monitor/Simulator] menu, select [Transfer to PLC] to display the [Transfer Program] dialog box.
- (12) Check [Unit setting info] and [Program], and then click [Execute]. The setting information is transferred.

This completes the setting of the External Device.

3.8 Setting Example 8

■ GP-Pro EX Settings

To display the setup screen, from the [System Settings] workspace, select [Device/PLC].

Device/PLC 1

Summary [Change Device/PLC](#)

Maker Series Port

Text Data Mode [Change](#)

Communication Settings

RS232C
 RS422/485(2wire)
 RS422/485(4wire)

Speed

Data Length 7 8

Parity NONE EVEN ODD

Stop Bit 1 2

Flow Control NONE ER(DTR/CTS) XON/XOFF

Timeout (sec)

Retry

Wait To Send (ms)

RI / VCC
 VCC

In the case of RS232C, you can select the 9th pin to RI (Input) or VCC (5V Power Supply). If you use the Digital's RS232C Isolation Unit, please select it to VCC.

Device-Specific Settings

Allowable Number of Devices/PLCs

Number	Device Name	Settings
<input type="button" value="1"/>	<input type="text" value="PLC1"/>	<input type="text" value="Series=KV-700/1000"/>

◆ Device Setting

To display the [Individual Device Settings] dialog box, select the external device and click  [Settings] from [Device-Specific Settings] in the [Device/PLC] window.

Individual Device Settings

PLC1

Series

Please reconfirm all of address settings that you are using if you have changed the series.

■ External Device Settings

Use the KEYENCE Corporation ladder software (KV STUDIO Ver. 4 or later) to configure communication settings for the External Device.

Refer to your External Device manual for details.

- (1) Start up the ladder software.
- (2) From the [File] menu, select [New Project] and display the [New Project] dialog box.
- (3) Type a project name in [Project Name], select the External Device to use under [PLC model], and click [OK].
- (4) Click [Yes] in the [Confirm unit setting information] dialog box and display the [Unit Editor] window.
- (5) Select "KV-L20V" from the displayed unit list on the [Select unit] tab, and drag & drop it to the unit placement area.
- (6) Double-click "KV-L20V" in the unit placement area.
- (7) Configure the following communication settings on the [Setup unit] tab.

Setup Items		Setup Description
Port 1	Operation Mode	KV BUILDER/KV STUDIO mode
	Interface	RS-232C
	Baud Rate	Auto
	Data Bit Length	8 bits
	Start Bit	1 bit
	Stop Bit	1 bit
	Parity	Even
	Check Sum	None
	RS/CS Flow Control	Disabled
Station No.	Station No.	0
Detail Settings	Transfer Timeout (sec.)	3

- (8) From the [Convert] menu, select [Auto-assign relay/DM].
- (9) From the [File] menu, select [Close] and display the [Unit Editor] dialog box.
- (10) Click [Yes].
- (11) From the [Monitor/Simulator] menu, select [Transfer to PLC] to display the [Transfer Program] dialog box.
- (12) Check [Unit setting info] and [Program], and then click [Execute]. The setting information is transferred.

This completes the setting of the External Device.

3.9 Setting Example 9

■ SGP-Pro EX Settings

To display the setup screen, from the [System Settings] workspace, select [Device/PLC].

The screenshot shows the 'Device/PLC 1' configuration window. It is divided into several sections:

- Summary:**
 - Maker: KEYENCE Corporation
 - Series: KV-700/1000/3000/5000 CPU Direct
 - Port: COM1
 - Text Data Mode: 2 (with a 'Change' link)
- Communication Settings:**
 - SI0 Type: RS232C, RS422/485(2wire), RS422/485(4wire)
 - Speed: 19200 (dropdown)
 - Data Length: 7, 8
 - Parity: NONE, EVEN, ODD
 - Stop Bit: 1, 2
 - Flow Control: NONE, ER(DTR/CTS), XON/XOFF
 - Timeout: 3 (spin box) (sec)
 - Retry: 2 (spin box)
 - Wait To Send: 0 (spin box) (ms)
- RI / VCC:**
 - RI, VCC
 - Text: "In the case of RS232C, you can select the 9th pin to RI (Input) or VCC (5V Power Supply). If you use the Digital's RS232C Isolation Unit, please select it to VCC."
 - Default button
- Device-Specific Settings:**
 - Allowable Number of Devices/PLCs: 1
 - Table with columns: Number, Device Name, Settings
 - Row 1: 1, PLC1, Settings (Series=KV-700/1000)

◆ Device Setting

To display the [Individual Device Settings] dialog box, select the external device and click  [Settings] from [Device-Specific Settings] in the [Device/PLC] window.

The screenshot shows the 'Individual Device Settings' dialog box for 'PLC1'. It contains:

- Series: KV-700/1000 (dropdown)
- Text: "Please reconfirm all of address settings that you are using if you have changed the series."
- Default button
- OK (O) button
- Cancel button

■ External Device Settings

Use the KEYENCE Corporation ladder software (KV STUDIO Ver. 4 or later) to configure communication settings for the External Device.

Refer to your External Device manual for details.

- (1) Start up the ladder software.
- (2) From the [File] menu, select [New Project] and display the [New Project] dialog box.
- (3) Type a project name in [Project Name], select the External Device to use under [PLC model], and click [OK].
- (4) Click [Yes] in the [Confirm unit setting information] dialog box and display the [Unit Editor] window.
- (5) Select "KV-L20V" from the displayed unit list on the [Select unit] tab, and drag & drop it to the unit placement area.
- (6) Double-click "KV-L20V" in the unit placement area.
- (7) Configure the following communication settings on the [Setup unit] tab.

Setup Items		Setup Description
Port 2	Operation Mode	KV BUILDER/KV STUDIO mode
	Interface	RS-232C
	Baud Rate	Auto
	Data Bit Length	8 bits
	Start Bit	1 bit
	Stop Bit	1 bit
	Parity	Even
	Check Sum	None
Station No.	Station No.	0
Detail Settings	Transfer Timeout (sec.)	3

- (8) From the [Convert] menu, select [Auto-assign relay/DM].
- (9) From the [File] menu, select [Close] and display the [Unit Editor] dialog box.
- (10) Click [Yes].
- (11) From the [Monitor/Simulator] menu, select [Transfer to PLC] to display the [Transfer Program] dialog box.
- (12) Check [Unit setting info] and [Program], and then click [Execute]. The setting information is transferred.

This completes the setting of the External Device.

3.10 Setting Example 10

■ GP-Pro EX Settings

To display the setup screen, from the [System Settings] workspace, select [Device/PLC].

Device/PLC 1

Summary [Change Device/PLC](#)

Maker Series Port

Text Data Mode [Change](#)

Communication Settings

SID Type RS232C RS422/485(2wire) RS422/485(4wire)

Speed

Data Length 7 8

Parity NONE EVEN ODD

Stop Bit 1 2

Flow Control NONE ER(DTR/CTS) XON/XOFF

Timeout (sec)

Retry

Wait To Send (ms)

RI / VCC RI VCC

In the case of RS232C, you can select the 9th pin to RI (Input) or VCC (5V Power Supply). If you use the Digital's RS232C Isolation Unit, please select it to VCC.

Device-Specific Settings

Allowable Number of Devices/PLCs

Number	Device Name	Settings
1	<input type="text" value="PLC1"/>	<input type="text" value="Series=KV-700/1000"/>

◆ Device Setting

To display the [Individual Device Settings] dialog box, select the external device and click [Settings] from [Device-Specific Settings] in the [Device/PLC] window.

Individual Device Settings

PLC1

Series

Please reconfirm all of address settings that you are using if you have changed the series.

■ External Device Settings

Use the KEYENCE Corporation ladder software (KV STUDIO Ver. 4 or later) to configure communication settings for the External Device.

Refer to your External Device manual for details.

- (1) Start up the ladder software.
- (2) From the [File] menu, select [New Project] and display the [New Project] dialog box.
- (3) Type a project name in [Project Name], select the External Device to use under [PLC model], and click [OK].
- (4) Click [Yes] in the [Confirm unit setting information] dialog box and display the [Unit Editor] window.
- (5) Select "KV-L20V" from the displayed unit list on the [Select unit] tab, and drag & drop it to the unit placement area.
- (6) Double-click "KV-L20V" in the unit placement area.
- (7) Configure the following communication settings on the [Setup unit] tab.

Setup Items		Setup Description
Port 2	Operation Mode	KV BUILDER/KV STUDIO mode
	Interface	RS-422A/485 (4wire)
	Baud Rate	Auto
	Data Bit Length	8 bits
	Start Bit	1 bit
	Stop Bit	1 bit
	Parity	Even
	Check Sum	None
Station No.	Station No.	0
Detail Settings	Transfer Timeout (sec.)	3

- (8) From the [Convert] menu, select [Auto-assign relay/DM].
- (9) From the [File] menu, select [Close] and display the [Unit Editor] dialog box.
- (10) Click [Yes].
- (11) From the [Monitor/Simulator] menu, select [Transfer to PLC] to display the [Transfer Program] dialog box.
- (12) Check [Unit setting info] and [Program], and then click [Execute]. The setting information is transferred.

This completes the setting of the External Device.

3.11 Setting Example 11

■ GP-Pro EX Settings

To display the setup screen, from the [System Settings] workspace, select [Device/PLC].

◆ Device Setting

To display the [Individual Device Settings] dialog box, select the external device and click  [Settings] from [Device-Specific Settings] in the [Device/PLC] window.

■ External Device Settings

There are no settings on the External Device. The speed automatically switches according to the Display setting.

3.12 Setting Example 12

■ GP-Pro EX Settings

To display the setup screen, from the [System Settings] workspace, select [Device/PLC].

Device/PLC 1

Summary [Change Device/PLC](#)

Maker: KEYENCE Corporation Series: KV-700/1000/3000/5000 CPU Direct Port: COM1

Text Data Mode: 2 [Change](#)

Communication Settings

SID Type: RS232C RS422/485(2wire) RS422/485(4wire)

Speed: 19200

Data Length: 7 8

Parity: NONE EVEN ODD

Stop Bit: 1 2

Flow Control: NONE ER(DTR/CTS) XON/XOFF

Timeout: 3 (sec)

Retry: 2

Wait To Send: 0 (ms)

RI / VCC: RI VCC

In the case of RS232C, you can select the 9th pin to RI (Input) or VCC (5V Power Supply). If you use the Digital's RS232C Isolation Unit, please select it to VCC.

Default

Device-Specific Settings

Allowable Number of Devices/PLCs: 1

Number	Device Name	Settings
1	PLC1	Series=KV-3000/5000

◆ Device Setting

To display the [Individual Device Settings] dialog box, select the external device and click [Settings] from [Device-Specific Settings] in the [Device/PLC] window.

Individual Device Settings

PLC1

Series: KV-3000/5000

Please reconfirm all of address settings that you are using if you have changed the series.

Default

OK (O) Cancel

■ External Device Settings

Use the KEYENCE Corporation ladder software (KV STUDIO Ver. 4 or later) to configure communication settings for the External Device.

Refer to your External Device manual for details.

- (1) Start up the ladder software.
- (2) From the [File] menu, select [New Project] and display the [New Project] dialog box.
- (3) Type a project name in [Project Name], select the External Device to use under [PLC model], and click [OK].
- (4) Click [Yes] in the [Confirm unit setting information] dialog box and display the [Unit Editor] window.
- (5) Select "KV-L20V" from the displayed unit list on the [Select unit] tab, and drag & drop it to the unit placement area.
- (6) Double-click "KV-L20V" in the unit placement area.
- (7) Configure the following communication settings on the [Setup unit] tab.

Setup Items		Setup Description
Port 1	Operation Mode	KV BUILDER/KV STUDIO mode
	Interface	RS-232C
	Baud Rate	Auto
	Data Bit Length	8 bits
	Start Bit	1 bit
	Stop Bit	1 bit
	Parity	Even
	Check Sum	None
	RS/CS Flow Control	Disabled
Station No.	Station No.	0
Detail Settings	Transfer Timeout (sec.)	3

- (8) From the [Convert] menu, select [Auto-assign relay/DM].
- (9) From the [File] menu, select [Close] and display the [Unit Editor] dialog box.
- (10) Click [Yes].
- (11) From the [Monitor/Simulator] menu, select [Transfer to PLC] to display the [Transfer Program] dialog box.
- (12) Check [Unit setting info] and [Program], and then click [Execute]. The setting information is transferred.

This completes the setting of the External Device.

3.13 Setting Example 13

■ GP-Pro EX Settings

To display the setup screen, from the [System Settings] workspace, select [Device/PLC].

Device/PLC 1

Summary [Change Device/PLC](#)

Maker: KEYENCE Corporation Series: KV-700/1000/3000/5000 CPU Direct Port: COM1

Text Data Mode: 2 [Change](#)

Communication Settings

SID Type: RS232C RS422/485(2wire) RS422/485(4wire)

Speed: 19200

Data Length: 7 8

Parity: NONE EVEN ODD

Stop Bit: 1 2

Flow Control: NONE ER(DTR/CTS) XON/XOFF

Timeout: 3 (sec)

Retry: 2

Wait To Send: 0 (ms)

RI / VCC: RI VCC

In the case of RS232C, you can select the 9th pin to RI (Input) or VCC (5V Power Supply). If you use the Digital's RS232C Isolation Unit, please select it to VCC.

Default

Device-Specific Settings

Number	Device Name	Settings
1	PLC1	Series=KV-3000/5000

◆ Device Setting

To display the [Individual Device Settings] dialog box, select the external device and click  [Settings] from [Device-Specific Settings] in the [Device/PLC] window.

Individual Device Settings

PLC1

Series: KV-3000/5000

Please reconfirm all of address settings that you are using if you have changed the series.

Default

OK (O) Cancel

■ External Device Settings

Use the KEYENCE Corporation ladder software (KV STUDIO Ver. 4 or later) to configure communication settings for the External Device.

Refer to your External Device manual for details.

- (1) Start up the ladder software.
- (2) From the [File] menu, select [New Project] and display the [New Project] dialog box.
- (3) Type a project name in [Project Name], select the External Device to use under [PLC model], and click [OK].
- (4) Click [Yes] in the [Confirm unit setting information] dialog box and display the [Unit Editor] window.
- (5) Select "KV-L20V" from the displayed unit list on the [Select unit] tab, and drag & drop it to the unit placement area.
- (6) Double-click "KV-L20V" in the unit placement area.
- (7) Configure the following communication settings on the [Setup unit] tab.

Setup Items		Setup Description
Port 2	Operation Mode	KV BUILDER/KV STUDIO mode
	Interface	RS-232C
	Baud Rate	Auto
	Data Bit Length	8 bits
	Start Bit	1 bit
	Stop Bit	1 bit
	Parity	Even
	Check Sum	None
Station No.	Station No.	0
Detail Settings	Transfer Timeout (sec.)	3

- (8) From the [Convert] menu, select [Auto-assign relay/DM].
- (9) From the [File] menu, select [Close] and display the [Unit Editor] dialog box.
- (10) Click [Yes].
- (11) From the [Monitor/Simulator] menu, select [Transfer to PLC] to display the [Transfer Program] dialog box.
- (12) Check [Unit setting info] and [Program], and then click [Execute]. The setting information is transferred.

This completes the setting of the External Device.

3.14 Setting Example 14

■ GP-Pro EX Settings

To display the setup screen, from the [System Settings] workspace, select [Device/PLC].

Device/PLC 1

Summary [Change Device/PLC](#)

Maker: KEYENCE Corporation Series: KV-700/1000/3000/5000 CPU Direct Port: COM1

Text Data Mode: 2 [Change](#)

Communication Settings

SID Type: RS232C RS422/485(2wire) RS422/485(4wire)

Speed: 19200

Data Length: 7 8

Parity: NONE EVEN ODD

Stop Bit: 1 2

Flow Control: NONE ER(DTR/CTS) XON/XOFF

Timeout: 3 (sec)

Retry: 2

Wait To Send: 0 (ms)

RI / VCC: RI VCC

In the case of RS232C, you can select the 9th pin to RI (Input) or VCC (5V Power Supply). If you use the Digital's RS232C Isolation Unit, please select it to VCC.

Default

Device-Specific Settings

Allowable Number of Devices/PLCs: 1

Number	Device Name	Settings
1	PLC1	Series=KV-3000/5000

◆ Device Setting

To display the [Individual Device Settings] dialog box, select the external device and click  [Settings] from [Device-Specific Settings] in the [Device/PLC] window.

Individual Device Settings

PLC1

Series: KV-3000/5000

Please reconfirm all of address settings that you are using if you have changed the series.

Default

OK (O) Cancel

■ External Device Settings

Use the KEYENCE Corporation ladder software (KV STUDIO Ver. 4 or later) to configure communication settings for the External Device.

Refer to your External Device manual for details.

- (1) Start up the ladder software.
- (2) From the [File] menu, select [New Project] and display the [New Project] dialog box.
- (3) Type a project name in [Project Name], select the External Device to use under [PLC model], and click [OK].
- (4) Click [Yes] in the [Confirm unit setting information] dialog box and display the [Unit Editor] window.
- (5) Select "KV-L20V" from the displayed unit list on the [Select unit] tab, and drag & drop it to the unit placement area.
- (6) Double-click "KV-L20V" in the unit placement area.
- (7) Configure the following communication settings on the [Setup unit] tab.

Setup Items		Setup Description
Port 2	Operation Mode	KV BUILDER/KV STUDIO mode
	Interface	RS-422A/485 (4wire)
	Baud Rate	Auto
	Data Bit Length	8 bits
	Start Bit	1 bit
	Stop Bit	1 bit
	Parity	Even
	Check Sum	None
Station No.	Station No.	0
Detail Settings	Transfer Timeout (sec.)	3

- (8) From the [Convert] menu, select [Auto-assign relay/DM].
- (9) From the [File] menu, select [Close] and display the [Unit Editor] dialog box.
- (10) Click [Yes].
- (11) From the [Monitor/Simulator] menu, select [Transfer to PLC] to display the [Transfer Program] dialog box.
- (12) Check [Unit setting info] and [Program], and then click [Execute]. The setting information is transferred.

This completes the setting of the External Device.

4 Setup Items

Set up the Display's communication settings in GP-Pro EX or in the Display's off-line mode.

The setting of each parameter must match that of the External Device.

 "3 Communication Settings" (page 8)

4.1 Setup Items in GP-Pro EX

■ Communication Settings

To display the setup screen, from the [System Settings] workspace, select [Device/PLC].

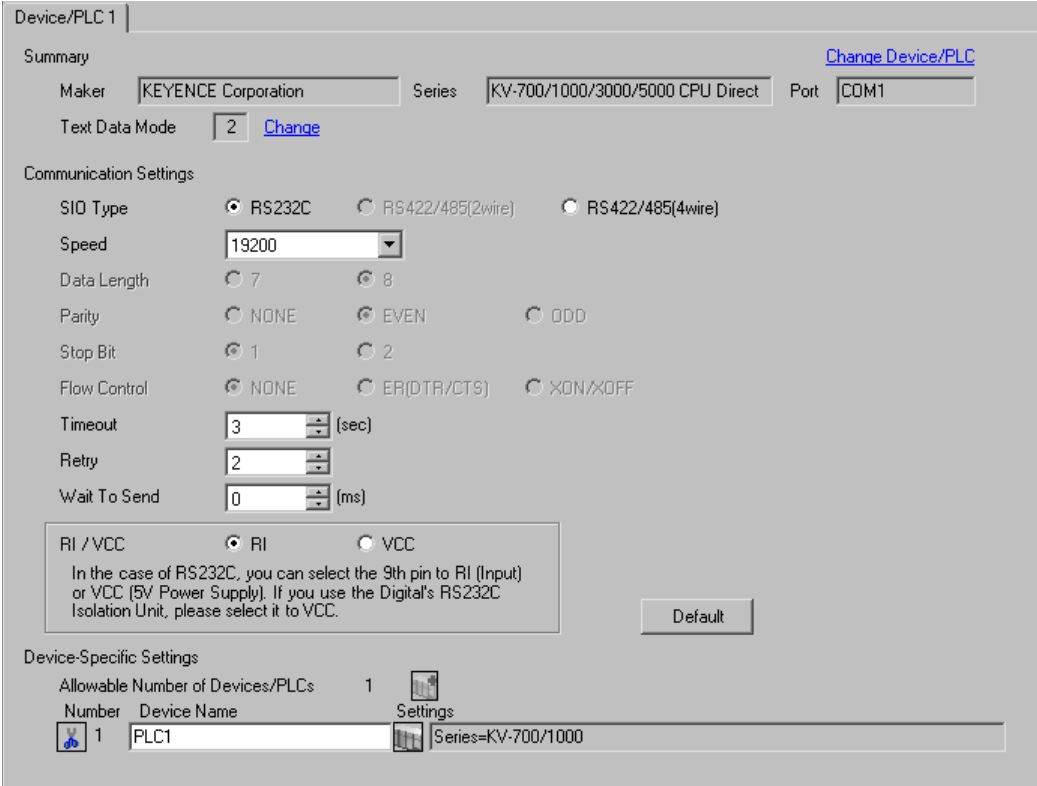

Device/PLC 1 | [Change Device/PLC](#)

Summary

Maker: KEYENCE Corporation Series: KV-700/1000/3000/5000 CPU Direct Port: COM1

Text Data Mode: 2 [Change](#)

Communication Settings

SIO Type: RS232C RS422/485(2wire) RS422/485(4wire)

Speed: 19200

Data Length: 7 8

Parity: NONE EVEN ODD

Stop Bit: 1 2

Flow Control: NONE ER(DTR/CTS) XON/XOFF

Timeout: 3 (sec)

Retry: 2

Wait To Send: 0 (ms)

RI / VCC: RI VCC

In the case of RS232C, you can select the 9th pin to RI (Input) or VCC (5V Power Supply). If you use the Digital's RS232C Isolation Unit, please select it to VCC.

[Default](#)

Device-Specific Settings

Number	Device Name	Settings
1	PLC1	Series=KV-700/1000

Setup Items	Setup Description
SIO Type	Select the SIO type for communicating with the External Device.
Speed	Select the communication speed between the External Device and the Display.
Data Length	Select a data length.
Parity	Select how to check parity.
Stop Bit	Select a stop bit length.
Flow Control	Select the communication control method to prevent overflow of transmission and reception data.
Timeout	Enter the time (s) for which the Display waits for the response from the External Device, from "1 to 127".

Continued to next page.

Setup Items	Setup Description
Retry	In case of no response from the External Device, enter how many times the Display retransmits the command, from "0 to 255".
Wait To Send	Enter the standby time (ms) from when the Display receives packets until it transmits the next command, from "0 to 255".
RI/VCC	You can switch between RI/VCC for the 9th pin when you select RS-232C for SIO type. To connect to the IPC, switch between RI/5V using the IPC selector switch. Refer to your IPC manual for details.

■ Device Setting

To display the [Individual Device Settings] dialog box, select the external device and click  [Settings] from [Device-Specific Settings] in the [Device/PLC] window.



Setup Items	Setup Description
Series	Select the series of the External Device.

4.2 Setup Items in Off-line Mode

NOTE

- Refer to the Maintenance/Troubleshooting manual for information on how to enter off-line mode or about the operation.
- Cf. Maintenance/Troubleshooting Manual "2.2 Off-line Mode"
- The number of the setup items to be displayed for 1 page in the off-line mode depends on the Display in use. Please refer to the Reference manual for details.

■ Communication Settings

To display the setting screen, touch [Device/PLC Settings] from [Peripheral Equipment Settings] in off-line mode. Touch the External Device you want to set from the displayed list.

Comm.	Device	Option		
KV-700/1000/3000/5000 CPU Direct		[COM1]	Page 1/1	
SIO Type		RS232C	▼	
Speed		19200	▼	
Data Length		8		
Parity		EVEN		
Stop Bit		1		
Flow Control		NONE		
Timeout(s)		3	▼	▲
Retry		2	▼	▲
Wait to Send(ms)		0	▼	▲
Exit		Back		2008/01/08 19:19:14

Setup Items	Setup Description
SIO Type	<p>Select the SIO type for communicating with the External Device.</p> <p>IMPORTANT</p> <p>In the communication settings, set [SIO Type] correctly according to the serial interface specifications of the Display.</p> <p>If you select an SIO type that the serial interface does not support, proper operation cannot be guaranteed.</p> <p>Refer to your Display manual for details on the serial interface specifications.</p>

Continued to next page.

Setup Items	Setup Description
Speed	Select the communication speed between the External Device and the Display.
Data Length	Data length is displayed.
Parity	The parity check method is displayed.
Stop Bit	Stop bit length is displayed.
Flow Control	The communication control method to prevent overflow of transmission and reception data.
Timeout	Enter the time (s) for which the Display waits for the response from the External Device, from "1 to 127".
Retry	In case of no response from the External Device, enter how many times the Display retransmits the command, from "0 to 255".
Wait To Send	Enter the standby time (ms) from when the Display receives packets until it transmits the next command, from "0 to 255".

■ Device Setting

To display the setting screen, touch [Device/PLC Settings] from [Peripheral Equipment Settings]. Touch the External Device you want to set from the list that appears, and touch [Device].

Comm.	Device	Option		
KV-700/1000/3000/5000 CPU Direct		[COM1]	Page 1/1	
Device/PLC Name	PLC1			▼
Series	KV-700/1000			
	Exit		Back	2008/01/08 19:19:23

Setup Items	Setup Description
Device/PLC Name	Select the External Device to set. Device/PLC Name is the title of the External Device set with GP-Pro EX. (Initial value [PLC1])
Series	Displays the series of the External Device.

■ Option

To display the setting screen, touch [Device/PLC Settings] from [Peripheral Equipment Settings]. Touch the External Device you want to set from the list that appears, and touch [Option].

Comm.	Device	Option		
KV-700/1000/3000/5000 CPU Direct		[COM1]	Page 1/1	
RI / VCC <input checked="" type="radio"/> RI <input type="radio"/> VCC In the case of RS232C, you can select the 9th pin to RI(Input) or VCC(5V Power Supply). If you use the Digital's RS232C Isolation Unit, please select it to VCC.				
Exit		Back		2008/01/08 19:19:33

Setup Items	Setup Description
RI/VCC	You can switch between RI/VCC for the 9th pin when you select RS-232C for SIO type. To connect to the IPC, you need to switch between RI/5V using the IPC selector switch. Refer to your IPC manual for details.

NOTE

- GP-4100 series do not have the [Option] setting in the off-line mode.

5 Cable Diagrams

The cable diagrams shown below may be different from the cable diagrams recommended by KEYENCE Corporation. Please be assured there is no operational problem in applying the cable diagrams shown in this manual.

- The FG pin on the External Device must be D-class grounded. Refer to your External Device manual for details.
- The SG and FG are connected inside the Display. If you connect the External Device to the SG, do not form any short-circuit loop in the system design.
- If the communication is not stable because of noise or other factors, connect an isolation unit.

Cable Diagram 1

Display (Connection Port)	Cable		Remarks
GP3000 (COM1) ST (COM1) IPC*1 PC/AT	1A	D-sub 9Pin by KEYENCE Corporation OP-26486 + Modular cable by KEYENCE Corporation OP-26487 (2.5m)	
GP-4105 (COM1)	1B	User-created cable + D-sub 9Pin by KEYENCE Corporation OP-26486 + Modular cable by KEYENCE Corporation OP-26487 (2.5m)	

*1 Available only with COM ports that support RS-232C.

 ■ IPC COM Port (page 5)

1A)

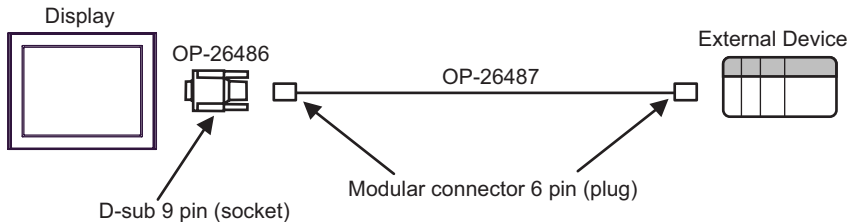

1B)

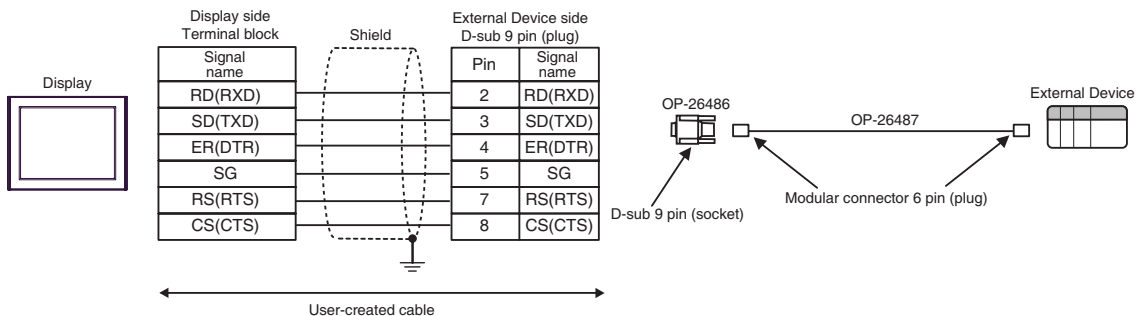

Cable Diagram 2

Display (Connection Port)	Cable		Remarks
GP3000 (COM1) ST (COM1) IPC*1 PC/AT	2A	User-created cable	The cable length must be 15m or less.
GP-4105 (COM1)	2B	User-created cable	

*1 Available only with COM ports that support RS-232C.

 ■ IPC COM Port (page 5)

2A)

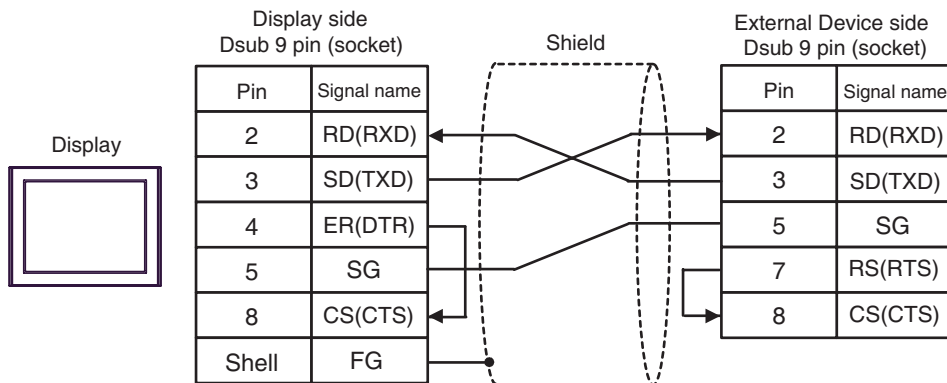

2B)

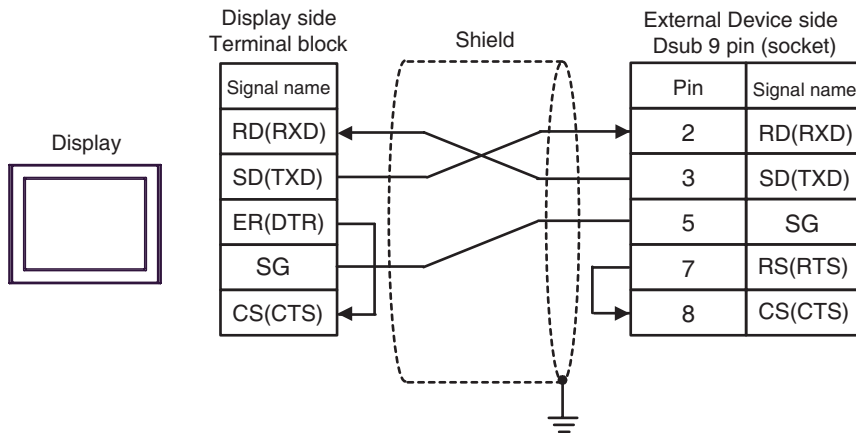

Cable Diagram 3

Display (Connection Port)	Cable		Remarks
GP3000 (COM1) ST (COM1) IPC*1 PC/AT	3A	User-created cable	The cable length must be 15m or less.
GP-4105 (COM1)	3B	User-created cable	

*1 Available only with COM ports that support RS-232C.

☞ ■ IPC COM Port (page 5)

NOTE

- Set the PORT2 toggle switch on the External Device to "232C".

3A)

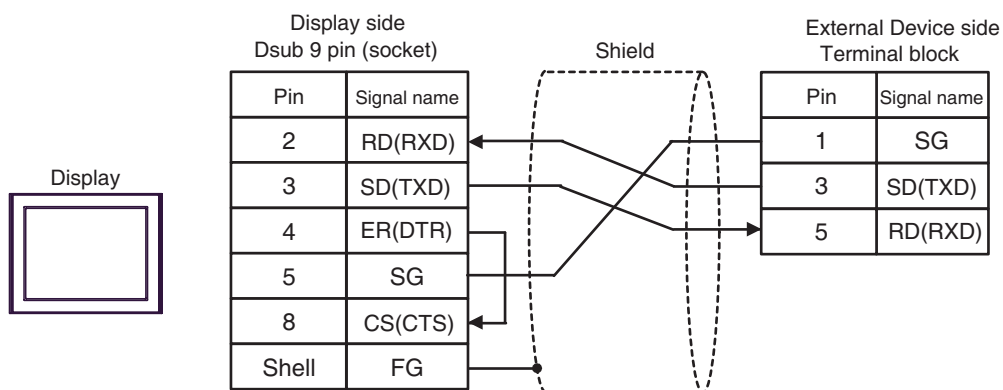

3B)

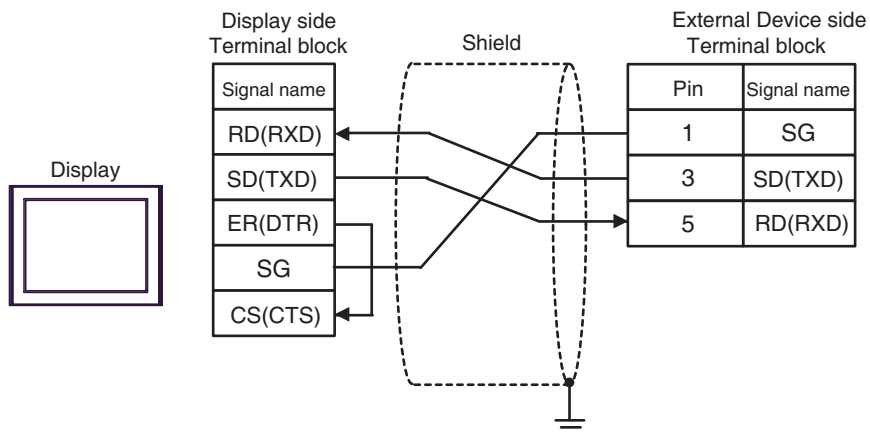

Cable Diagram 4

Display (Connection Port)	Cable		Remarks
GP3000* ¹ (COM1) AGP-3302B (COM2) ST* ² (COM2) IPC* ³	4A	COM port conversion adapter by Pro-face CA3-ADPCOM-01 + Connector terminal block conversion adapter by Pro-face CA3-ADPTRM-01 + User-created cable	The cable length must be 500m or less.
	4B	User-created cable	
GP3000* ¹ (COM2)	4C	Online adapter by Pro-face CA4-ADPONL-01 + Connector terminal block conversion adapter by Pro-face CA3-ADPTRM-01 + User-created cable	
	4D	Online adapter by Pro-face CA4-ADPONL-01 + User-created cable	
GP-4106 (COM1)	4E	User-created cable	

*1 All GP3000 models except AGP-3302B

*2 All ST models except AST-3211A and AST-3302B

*3 Available only with COM ports that support RS-422/485 (4wire).

 ■ IPC COM Port (page 5)

NOTE

- Set the PORT2 toggle switch on the External Device to "422A 485(4)". Also, turn ON the switch of the terminator.
- Pay attention that pole A and pole B are reversely named for the Display and the External Device.

4A)

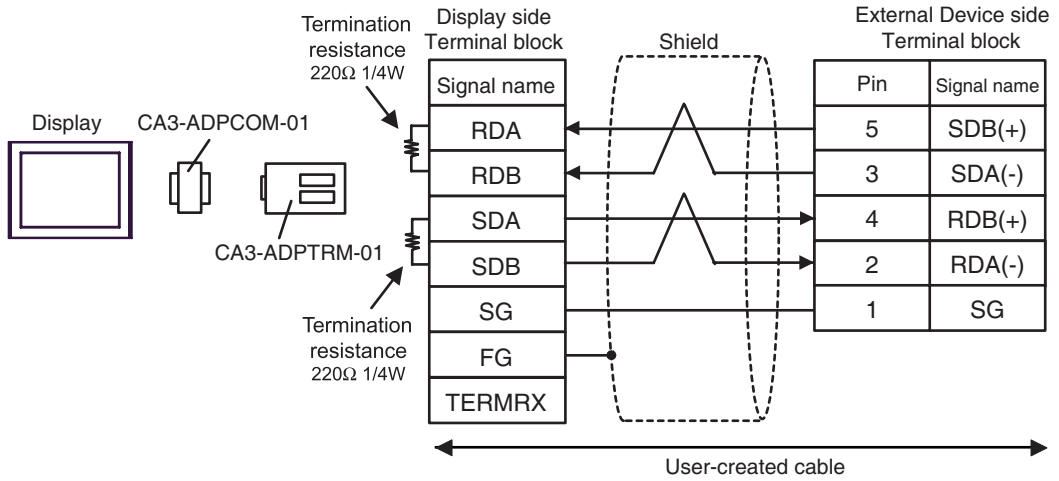

4B)

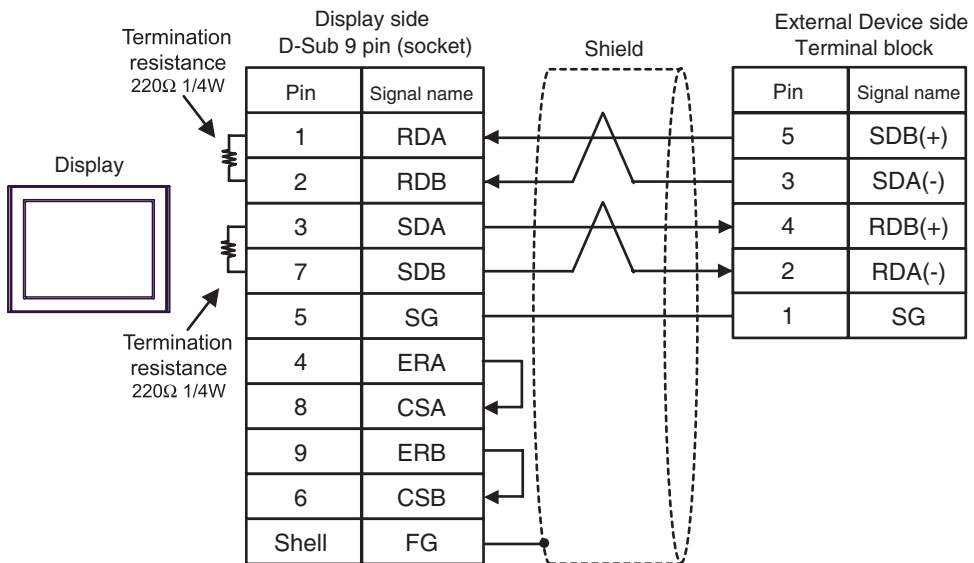

4C)

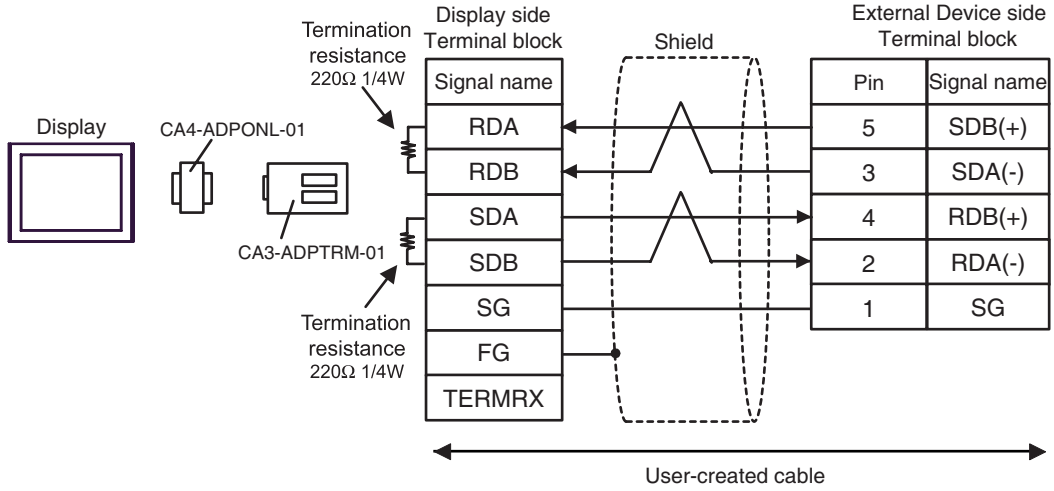

4D)

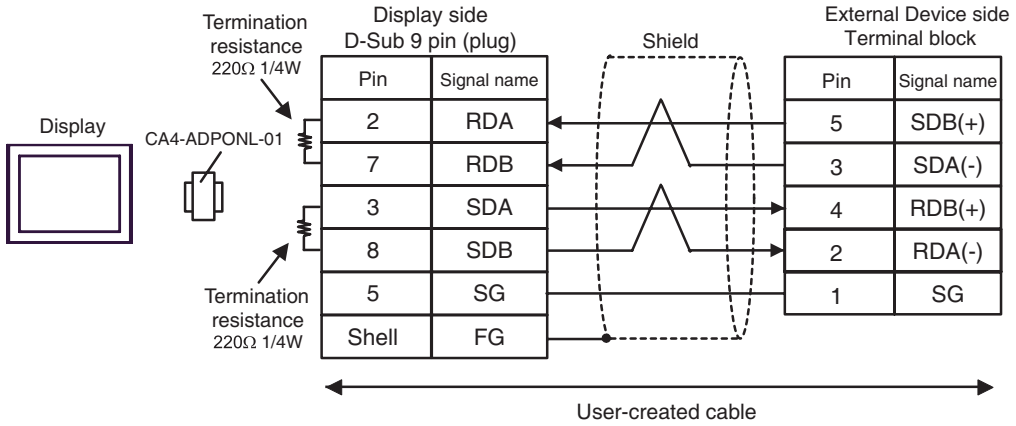

4E)

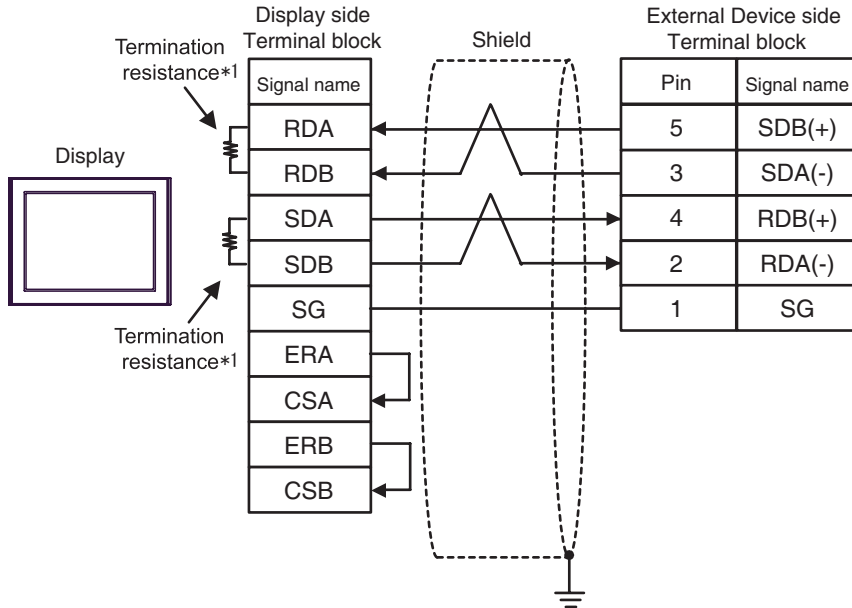

*1 The resistance in the Display is used as the termination resistance. Set the value of the DIP Switch on the rear of the Display as shown in the table below.

DIP Switch No.	Set Value
1	OFF
2	ON
3	OFF
4	ON

6 Supported Device

The range of supported device addresses is shown in the table below. Please note that the actual supported range for devices varies depending on the external device that is used. Please check the actual range in the external device manual.

6.1 KV-700 Series

 : This address can be specified as system data area.

Device	Bit Address	Word Address	32 bits	Remarks
Input Relay	00000 - 59915	000 - 599	L/H	
Output Relay				
Internal Auxiliary Relay				
Control Relay	CR0000 - CR3915	CR00 - CR39		
Timer (Contact)	T000 - T511	-----	-	
Counter (Contact)	C000 - C511	-----		
High-speed Counter Comparator (Contact)	CTC0 - CTC3	-----		*1
Timer (Setting Value)	-----	TS000 - TS511	L/H	*2
Counter (Setting Value)	-----	CS000 - CS511		*2
Timer (Current Value)	-----	TC000 - TC511		*2
Counter (Current Value)	-----	CC000 - CC511		*2
Data Memory	-----	DM00000 - DM39999		Bit 15
Temporary Data Memory	-----	TM000 - TM511		Bit 15
Control Memory	-----	CM0000 - CM3999		Bit 15
Digital Trimmer	-----	TRM0 - TRM7		*2
High-speed Counter (Current Value)	-----	CTH0 - CTH1		*2
High-speed Counter Comparator (Setting Value)	-----	CTC0 - CTC3		*2

*1 Write disable

*2 32-bit device

IMPORTANT

- When connecting KV-700 Series, use settings within the device address ranges above.
- If you try to access device addresses supported only by the KV-1000 Series devices, the following error messages display: "Error has been responded for device read command (Error Code(02)[(0x02)])" or "Error has been responded for device write command (Error Code(02)[(0x02)])".

NOTE

- Refer to the GP-Pro EX Reference Manual for system data area.

Cf. GP-Pro EX Reference Manual "Appendix 1.4 LS Area (Direct Access Method)"

- Refer to the precautions on manual notation for icons in the table.

 "Manual Symbols and Terminology"

6.2 KV-1000 Series

 : This address can be specified as system data area.

Device	Bit Address	Word Address	32 bits	Remarks
Input Relay	00000 - 59915	000 - 599	L/H	*1
Output Relay				*1
Internal Auxiliary Relay				*1
Internal Auxiliary Relay	MR00000 - MR99915	MR000 - MR999		
Latch Relay	LR00000 - LR99915	LR000 - LR999		
Control Relay	CR00000 - CR3915	CR00 - CR39		
Timer (Contact)	T0000 - T3999	-----	-	
Counter (Contact)	C0000 - C3999	-----		
High-speed Counter Comparator (Contact)	CTC0 - CTC3	-----		*2
Timer (Setting Value)	-----	TS0000 - TS3999	L/H	*3
Counter (Setting Value)	-----	CS0000 - CS3999		*3
Timer (Current Value)	-----	TC0000 - TC3999		*3
Counter (Current Value)	-----	CC0000 - CC3999		*3
Data Memory	-----	DM00000 - DM65534		Bit 15
Extension Data Memory EM	-----	EM00000 - EM65534		Bit 15
Extension Data Memory FM	-----	FM00000 - FM32766		Bit 15
Temporary Data Memory	-----	TM000 - TM511		Bit 15
Control Memory	-----	CM00000 - CM11998		Bit 15
Index Register	-----	Z01 - Z12		Bit 15 *4
Digital Trimmer	-----	TRM0 - TRM7		*3
High-speed Counter (Current Value)	-----	CTH0 - CTH1		*3
High-speed Counter Comparator (Setting Value)	-----	CTC0 - CTC3		*3

*1 R000 to R599 (R00000 to R59915) are shown in KV-1000, but 000 to 599 (00000 to 59915) in GP-Pro EX.

*2 Write disable

*3 32-bit device

*4 Do not write to the addresses Z11 and Z12. They are used in the system of the External Device.

NOTE

- Refer to the GP-Pro EX Reference Manual for system data area.

Cf. GP-Pro EX Reference Manual "Appendix 1.4 LS Area (Direct Access Method)"

- Refer to the precautions on manual notation for icons in the table.

 "Manual Symbols and Terminology"

6.3 KV-3000/5000 Series

 : This address can be specified as system data area.

Device		Bit Address	Word Address	32 bits	Remarks
Input Relay		R00000 - R99915	R000 - R999	L/H	
Output Relay					
Internal Auxiliary Relay					
Link Relay		B0000 - B3FFF	B000 - B3FF		
Internal Auxiliary Relay		MR00000 - MR99915	MR000 - MR999		
Latch Relay		LR00000 - LR99915	LR000 - LR999		
Control Relay		CR0000 - CR3915	CR00 - CR39		
Work Relay		VB0000 - VB3FFF	VB000 - VB3FF		
Timer (Contact)		T0000 - T3999	-----	-	
Counter (Contact)		C0000 - C3999	-----		
High-speed Counter Comparator (Contact)		CTC0 - CTC3	-----		*1
Timer (Setting Value)		-----	TS0000 - TS3999	L/H	*2
Counter (Setting Value)		-----	CS0000 - CS3999		*2
Timer (Current Value)		-----	TC0000 - TC3999		*2
Counter (Current Value)		-----	CC0000 - CC3999		*2
Data Memory		-----	DM00000 - DM65534		Bit 15
Extension Data Memory		-----	EM00000 - EM65534		Bit 15
File Register	Current Bank	-----	FM00000 - FM32767		Bit 15
	Serial Number System	-----	ZF000000 - ZF131071		Bit 15
Temporary Data Memory		-----	TM000 - TM511		Bit 15
Control Memory		-----	CM00000 - CM05999		Bit 15
Link Register		-----	W0000 - W3FFF	Bit 15	
Work Memory		-----	VM00000 - VM59999	Bit 15	
Index Register		-----	Z01 - Z12	*2 *3	
Digital Trimmer		-----	TRM0 - TRM7	*2	
High-speed Counter (Current Value)		-----	CTH0 - CTH1	*2	
High-speed Counter Comparator (Setting Value)		-----	CTC0 - CTC3	*2	

*1 Write disable

- *2 32-bit device
- *3 Do not write to the addresses Z11 and Z12. They are used in the system of the External Device.

NOTE

- Refer to the GP-Pro EX Reference Manual for system data area.
Cf. GP-Pro EX Reference Manual "Appendix 1.4 LS Area (Direct Access Method)"
 - Refer to the precautions on manual notation for icons in the table.
 "Manual Symbols and Terminology"
-

7 Device Code and Address Code

Use device code and address code if you select "Device Type & Address" for the address type in Data displays.

7.1 KV-700 Series

Device	Device Name	Device Code (HEX)	Address Code
Input Relay	-----	0080	Word Address
Output Relay			
Internal Auxiliary Relay			
Control Relay	CR	008A	Word Address
Timer (Setting Value)	TS	0062	Double Word Address
Counter (Setting Value)	CS	0063	Double Word Address
Timer (Current Value)	TC	0060	Double Word Address
Counter (Current Value)	CC	0061	Double Word Address
Data Memory	DM	0000	Word Address
Temporary Data Memory	TM	0001	Word Address
Control Memory	CM	0002	Word Address
Digital Trimmer	TRM	0064	Double Word Address
High-speed Counter (Current Value)	CTH	0065	Double Word Address
High-speed Counter Comparator (Setting Value)	CTC	0066	Double Word Address

7.2 KV-1000 Series

Device	Device Name	Device Code (HEX)	Address Code
Input Relay	-----	0080	Word Address
Output Relay			
Internal Auxiliary Relay			
Internal Auxiliary Relay	MR	0082	Word Address
Latch Relay	LR	0084	Word Address
Control Relay	CR	008A	Word Address
Timer (Setting Value)	TS	0062	Double Word Address
Counter (Setting Value)	CS	0063	Double Word Address
Timer (Current Value)	TC	0060	Double Word Address
Counter (Current Value)	CC	0061	Double Word Address
Data Memory	DM	0000	Word Address
Extension Data Memory	EM	0010	Word Address
Extension Data Memory	FM	0011	Word Address
Temporary Data Memory	TM	0001	Word Address
Control Memory	CM	0002	Word Address
Index Register	Z	0003	Word Address
Digital Trimmer	TRM	0064	Double Word Address
High-speed Counter (Current Value)	CTH	0065	Double Word Address
High-speed Counter Comparator (Setting Value)	CTC	0066	Double Word Address

7.3 KV-3000/5000 Series

Device		Device Name	Device Code (HEX)	Address Code
Input Relay		R	0080	Word Address
Output Relay				
Internal Auxiliary Relay				
Link Relay		B	008B	Word Address
Internal Auxiliary Relay		MR	0082	Word Address
Latch Relay		LR	0084	Word Address
Control Relay		CR	008A	Word Address
Work Relay		VB	008C	Word Address
Timer (Setting Value)		TS	0062	Double Word Address
Counter (Setting Value)		CS	0063	Double Word Address
Timer (Current Value)		TC	0060	Double Word Address
Counter (Current Value)		CC	0061	Double Word Address
Data Memory		DM	0000	Word Address
Extension Data Memory		EM	0010	Word Address
File Register	Current Bank	FM	0011	Word Address
	Serial Number System	ZF	0012	Word Address
Temporary Data Memory		TM	0001	Word Address
Control Memory		CM	0002	Word Address
Link Register		W	0013	Word Address
Work Memory		VM	0014	Word Address
Index Register		Z	0067	Double Word Address
Digital Trimmer		TRM	0064	Double Word Address
High-speed Counter (Current Value)		CTH	0065	Double Word Address
High-speed Counter Comparator (Setting Value)		CTC	0066	Double Word Address

8 Error Messages

Error messages are displayed on the Display screen as follows: "No.: Device Name: Error Message (Error Occurrence Area)". Each description is shown below.

Item	Description
No.	Error No.
Device Name	Name of the External Device where an error has occurred. Device name is a title of the External Device set with GP-Pro EX. (Initial value [PLC1])
Error Message	Displays messages related to an error that has occurred.
Error Occurrence Area	<p>Displays the IP address or device address of the External Device where an error has occurred, or error codes received from the External Device.</p> <p>NOTE</p> <ul style="list-style-type: none"> • IP address is displayed as "IP address (Decimal): MAC address (Hex)". • Device address is displayed as "Address: Device address". • Received error codes are displayed as "Decimal [Hex]".

Display Examples of Error Messages

"RHAA035: PLC1: Error has been responded for device write command (Error Code: 1 [01H])"

NOTE

- Refer to your External Device manual for details on received error codes.
- Refer to "When an error is displayed (Error Code List)" in "Maintenance/Troubleshooting Manual" for details on the error messages common to the driver.

◆ Error Codes Specific to the External Device

Error Code (HEX)	Error Description
02	Executed illegal access. <ul style="list-style-type: none"> • Wrote in the write disable device. • Accessed the nonexistent device or address.
04	Tried to communicate in the communication baud rate not supported by the External Device.
31	Accessed the device not defined as device in the External Device.*1
0B	Performed monitor read with the monitor unregistered.

*1 When you write to Timer (Contact/Current Value/Setting Value), Counter (Contact/Current Value/Setting Value), High-speed Counter, and High-speed Counter Comparator (Setting Value), the changed settings must be made in the in the ladder program in advance.

