



Hi4 Robot Driver

1	System Configuration.....	3
2	Selection of External Device	6
3	Example of Communication Setting.....	7
4	Setup Items.....	15
5	Cable Diagram	20
6	Supported Device.....	25
7	Device Code and Address Code.....	27
8	Error Messages.....	28

Introduction

This manual describes how to connect the Display and the External Device (target PLC).

In this manual, the connection procedure will be described by following the below sections:

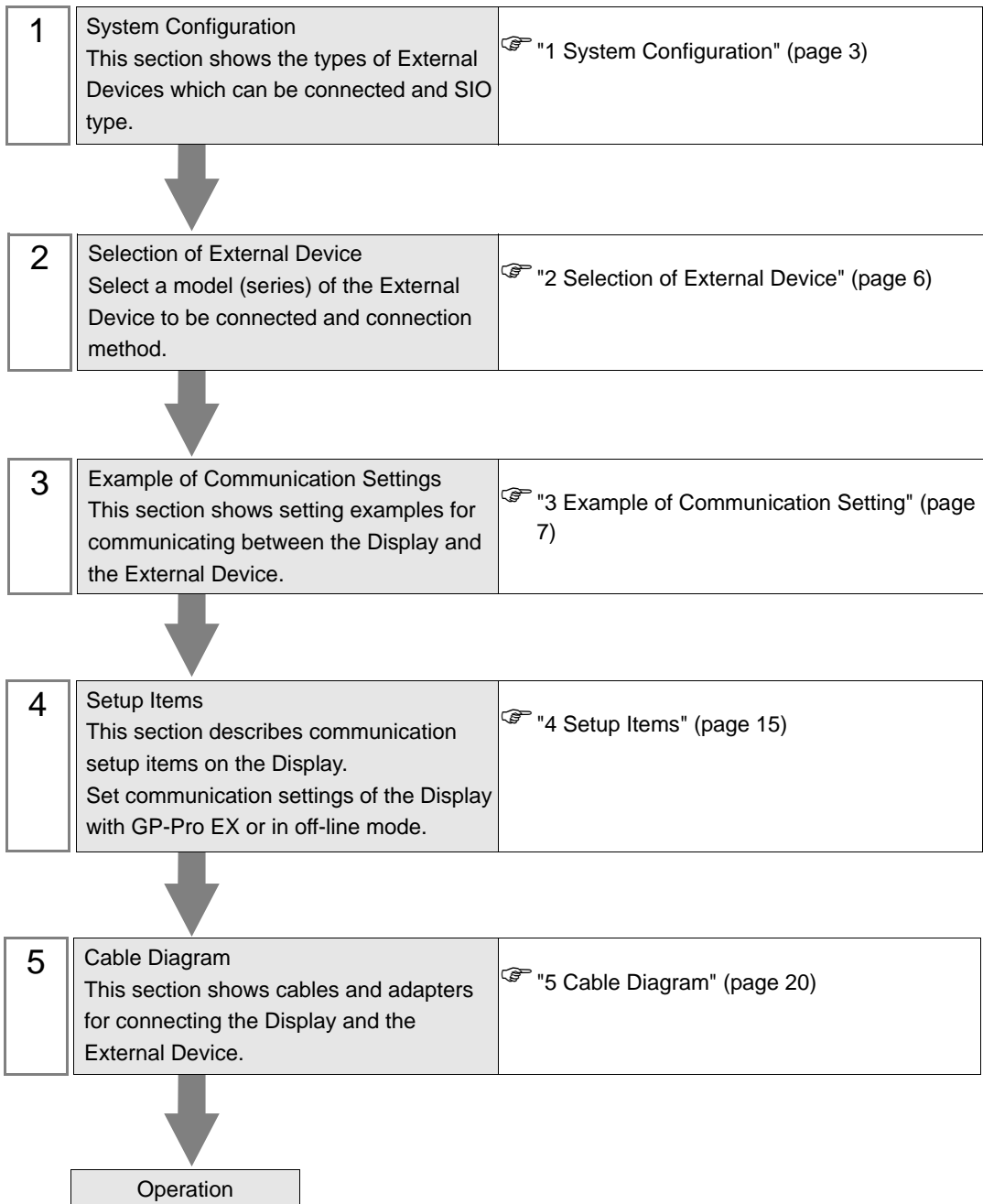

1 System Configuration

The system configuration in the case when the External Device of Hyundai Heavy Industries and the Display are connected is shown.

Series	CPU	Link I/F	SIO Type	Setting Example	Cable Diagram
Hi4 Robot	BD412 board	CNSIO port on CPU	RS-232C	"Setting Example 1" (page 7)	"Cable Diagram 1" (page 20)
		OPSIO port on CPU	RS-232C	"Setting Example 2" (page 9)	"Cable Diagram 2" (page 21)
			RS422/485 (4 wire)	"Setting Example 3" (page 12)	"Cable Diagram 3" (page 22)

■ Connection Configuration

- 1:1 connection

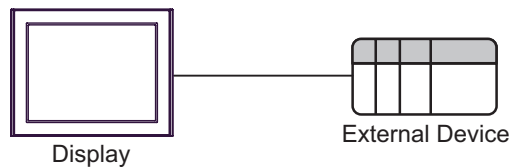

■ COM Port of IPC

When connecting IPC with External Device, the COM port which can be used changes with series and SIO type. Please refer to the manual of IPC for details.

Usable port

Series	Usable port		
	RS-232C	RS-422/485(4 wire)	RS-422/485(2 wire)
PS-2000B	COM1 ^{*1} , COM2, COM3 ^{*1} , COM4	-	-
PS-3450A, PS-3451A	COM1, COM2 ^{*1*2}	COM2 ^{*1*2}	COM2 ^{*1*2}
PS-3650A, PS-3651A	COM1 ^{*1}	-	-
PS-3700A (Pentium®4-M) PS-3710A	COM1 ^{*1} , COM2 ^{*1} , COM3 ^{*2} , COM4	COM3 ^{*2}	COM3 ^{*2}
PS-3711A	COM1 ^{*1} , COM2 ^{*2}	COM2 ^{*2}	COM2 ^{*2}
PL-3000B	COM1 ^{*1*2} , COM2 ^{*1} , COM3, COM4	COM1 ^{*1*2}	COM1 ^{*1*2}

*1 The RI/5V can be switched. Please switch with the change switch of IPC.

*2 It is necessary to set up the SIO type with the Dip switch. Please set up as follows according to SIO type to be used.

Dip switch setting: RS-232C

Dip switch	Setting	Description
1	OFF ^{*1}	Reserve (always OFF)
2	OFF	SIO type: RS-232C
3	OFF	
4	OFF	Output mode of SD (TXD) data: Always output
5	OFF	Terminal resistance (220Ω) insertion to SD (TXD): None
6	OFF	Terminal resistance (220Ω) insertion to RD (RXD): None
7	OFF	Short-circuit of SDA (TXA) and RDA (RXA): Does not Exist
8	OFF	Short-circuit of SDB (TXB) and RDB (RXB): Does not Exist
9	OFF	RS (RTS) Auto control mode: Disable
10	OFF	

*1 It is necessary to turn ON the set value, only when using PS-3450A and PS-3451A.

Dip switch setting: RS-422/485 (4 wire)

Dip switch	Setting	Description
1	OFF	Reserve (always OFF)
2	ON	SIO type: RS-422/485
3	ON	
4	OFF	Output mode of SD (TXD) data: Always output
5	OFF	Terminal resistance (220Ω) insertion to SD (TXD): None
6	OFF	Terminal resistance (220Ω) insertion to RD (RXD): None
7	OFF	Short-circuit of SDA (TXA) and RDA (RXA): Does not Exist
8	OFF	Short-circuit of SDB (TXB) and RDB (RXB): Does not Exist
9	OFF	RS (RTS) Auto control mode: Disable
10	OFF	

Dip switch setting: RS-422/485 (2 wire)

Dip switch	Setting	Description
1	OFF	Reserve (always OFF)
2	ON	SIO type: RS-422/485
3	ON	
4	OFF	Output mode of SD (TXD) data: Always output
5	OFF	Terminal resistance (220Ω) insertion to SD (TXD): None
6	OFF	Terminal resistance (220Ω) insertion to RD (RXD): None
7	ON	Short-circuit of SDA (TXA) and RDA (RXA): Exist
8	ON	Short-circuit of SDB (TXB) and RDB (RXB): Exist
9	ON	RS (RTS) Auto control mode: Enable
10	ON	

2 Selection of External Device

Select the External Device to be connected to the Display.

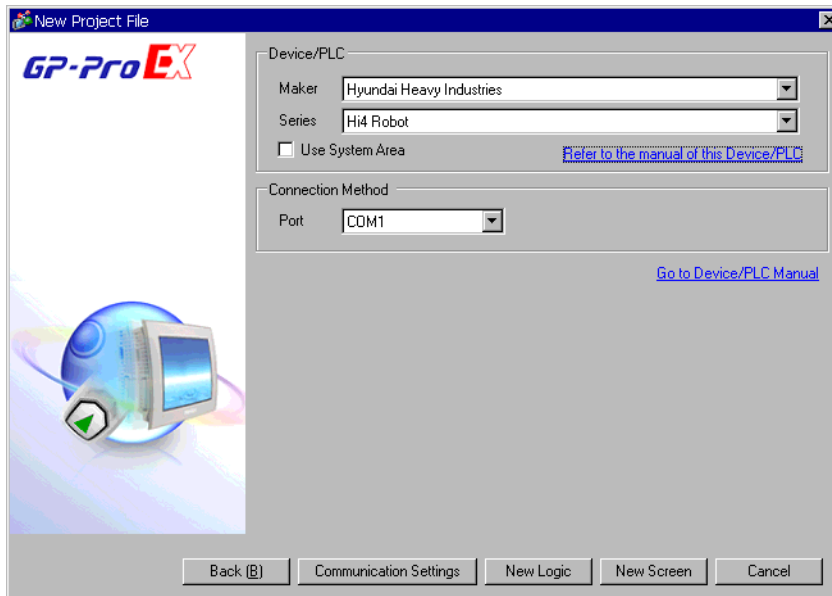

Setup Items	Setup Description
Maker	Select the maker of the External Device to be connected. Select "Hyundai Heavy Industries".
Series	Select a model (series) of the External Device to be connected and connection method. Select "Hi4 Robot". Check the External Device which can be connected in "Hi4 Robot" in system configuration. ☞ "1 System Configuration" (page 3)
Use System Area	Check this option when you synchronize the system data area of the Display and the device (memory) of the External Device. When synchronized, you can use the ladder program of the External Device to switch the display or display the window on the Display. Cf. GP-Pro EX Reference Manual "Appendix 1.4 LS Area (Direct Access Method)" This can be also set with GP-Pro EX or in off-line mode of the Display. Cf. GP-Pro EX Reference Manual "5.17.6 Setting Guide of [System Setting Window], Setting Guide of [Main Unit Settings], System Area Setting" Cf. Maintenance/Troubleshooting manual "2.15.1 Common to the Display", Setting Guide of [Main Unit Settings], System Area Setting"
Port	Select the Display port to be connected to the External Device.

3 Example of Communication Setting

The following shows examples of communication settings of the Display and the External Device, which is recommended by Pro-face.

3.1 Setting Example 1

■ Settings of GP-Pro EX

◆ Communication Settings

To display the setting screen, select [Device/PLC Settings] from [System setting window] in workspace.

Device/PLC 1

Summary [Change Device/PLC](#)

Maker: Hyundai Heavy Industries Series: Hi4 Robot Port: COM1

Text Data Mode: 1 [Change](#)

Communication Settings

SIO Type: RS232C RS422/485(2wire) RS422/485(4wire)

Speed: 38400

Data Length: 7 8

Parity: NONE EVEN ODD

Stop Bit: 1 2

Flow Control: NONE ER(DTR/CTS) XON/XOFF

Timeout: 3 (sec)

Retry: 2

Wait To Send: 0 (ms)

RI / VCC: RI VCC

In the case of RS232C, you can select the 9th pin to RI (Input) or VCC (5V Power Supply). If you use the Digital's RS232C Isolation Unit, please select it to VCC.

Default

Device-Specific Settings

Allowable Number of Devices/PLCs: 16

Number	Device Name	Settings
1	PLC1	Slave Address=1

◆ Device Setting

To display the setting screen, click  ([Setting]) of External Device you want to set from [Device-Specific Settings] of [Device/PLC Settings].

Individual Device Settings

PLC1

Slave Address: 1

Default

OK (O) Cancel

■ Settings of External Device

Communication setting of External Device using DIP switches and Teach Pendant of External Device.

Please refer to the manual of the External Device for more details.

◆ DIP Switch Setting

Set the DIP switch for built-in PLC.

DIP switches	Settings
SW01	OFF
SW02	OFF
SW03	OFF
SW04	OFF
SW05	ON
SW06	OFF
SW07	OFF
SW08	OFF

◆ Teach Pendant Setting

- 1 Press [PF2].
- 2 Select [2: Controller parameter]-[2: Serial ports]-[3: Serial Port #1(CNSIO)] in order from the displayed menu so as to display [Serial Port 1].
- 3 Set the setup items as follows.

Setup Items	Setting Value
Baudrate	38400
Character length	8
Stop bit	1
Parity bit	Disable
Echo	Disable
Port Usage	MODBUS

- 4 Press [PF2].
- 5 Select [2: Controller parameter]-[18: MODBUS environment setting] to displayed [MODBUS setting].
- 6 Set the setup items as follows.

Setup Items	Setting Value
Transmission mode	RTU
Slave Address	1

- 7 Press [SET].

3.2 Setting Example 2

■ Settings of GP-Pro EX

◆ Communication Settings

To display the setting screen, select [Device/PLC Settings] from [System setting window] in workspace.

◆ Device Setting

To display the setting screen, click  ([Setting]) of External Device you want to set from [Device-Specific Settings] of [Device/PLC Settings].

■ Settings of External Device

Communication setting of External Device using DIP switches and Teach Pendant of External Device.

Please refer to the manual of the External Device for more details.

◆ DIP Switch Setting

Set DIP switch for built-in PLC and DIP switch for OPSIO port

- DIP switch for built-in PLC

DIP switches	Settings
SW01	OFF
SW02	OFF
SW03	OFF
SW04	OFF
SW05	ON
SW06	OFF
SW07	OFF
SW08	OFF

- DIP switch for OPSIO port

DIP switch	Settings
SW01	ON
SW02	ON
SW03	OFF
SW04	OFF

◆ Teach Pendant Setting

- 1 Press [PF2].
- 2 Select [2: Controller parameter]-[2: Serial ports]-[3: Serial Port #1 (CNSIO)] in order from the displayed menu so as to display [Serial Port 1].
- 3 Set anything other than [MODBUS] to [Port Usage].
- 4 Select [4: Serial Port #2 (OPSIO)] in the same procedure so as to display [Serial Port 2].
- 5 Set the setup items as follows.

Setup Items	Setting Value
Baudrate	38400
Character length	8
Stop bit	1
Parity bit	Disable
Echo	Disable
Conv. RS422-RS485	Disable
Port Usage	MODBUS

- 6 Press [PF2].

7 Select [2: Controller parameter]-[18: MODBUS environment setting] to display [MODBUS setting].

8 Set the setup items as follows.

Setup Items	Setting Value
Transmission mode	RTU
Slave Address	1

9 Press [SET].

3.3 Setting Example 3

■ Settings of GP-Pro EX

◆ Communication Settings

To display the setting screen, select [Device/PLC Settings] from [System setting window] in workspace.

Device/PLC 1

Summary [Change Device/PLC](#)

Maker Series Port

Text Data Mode [Change](#)

Communication Settings

RS232C RS422/485(2wire) RS422/485(4wire)

Speed

Data Length 7 8

Parity NONE EVEN ODD

Stop Bit 1 2

Flow Control NONE ER(DTR/CTS) XON/XOFF

Timeout (sec)

Retry

Wait To Send (ms)

RI / VCC RI VCC

In the case of RS232C, you can select the 9th pin to RI (Input) or VCC (5V Power Supply). If you use the Digital's RS232C Isolation Unit, please select it to VCC.

Device-Specific Settings

Allowable Number of Devices/PLCs 16

Number	Device Name	Settings
1	PLC1	Slave Address=1

◆ Device Setting

To display the setting screen, click  ([Setting]) of External Device you want to set from [Device-Specific Settings] of [Device/PLC Settings].

Individual Device Settings

PLC1

Slave Address

■ Settings of External Device

Communication setting of External Device using DIP switches and Teach Pendant of External Device.

Please refer to the manual of the External Device for more details.

◆ DIP Switch Setting

Set DIP switch for built-in PLC and DIP switch for OPSIO port.

- DIP switch for built-in PLC

DIP switches	Settings
SW01	OFF
SW02	OFF
SW03	OFF
SW04	OFF
SW05	ON
SW06	OFF
SW07	OFF
SW08	OFF

- DIP switch for OPSIO port

DIP switch	Settings
SW01	OFF
SW02	OFF
SW03	ON
SW04	ON

◆ Teach Pendant Setting

- 1 Press [PF2].
- 2 Select [2: Controller parameter]-[2: Serial ports]-[3: Serial Port #1(CNSIO)] in order from the displayed menu so as to display [Serial Port 1].
- 3 Set anything other than [MODBUS] to [Port Usage].
- 4 Select [4: Serial Port #2 (OPSIO)] in the same procedure so as to display [Serial Port 2].
- 5 Set the setup items as follows.

Setup Items	Setting Value
Baudrate	38400
Character length	8
Stop bit	1
Parity bit	Disable
Echo	Disable
Conv. RS422-RS485	Disable
Port Usage	MODBUS

- 6 Press [PF2].

7 Select [2: Controller parameter]-[18: MODBUS environment setting] to display [MODBUS setting].

8 Set the setup items as follows.

Setup Items	Setting Value
Transmission mode	RTU
Slave Address	1

9 Press [SET].

4 Setup Items

Set communication settings of the Display with GP-Pro EX or in off-line mode of the Display.

The setting of each parameter must be identical to that of External Device.

☞ "3 Example of Communication Setting" (page 7)

4.1 Setup Items in GP-Pro EX

■ Communication Settings

To display the setting screen, select [Device/PLC Settings] from [System setting window] in workspace.

Device/PLC 1

Summary [Change Device/PLC](#)

Maker Series Port

Text Data Mode [Change](#)

Communication Settings

SIO Type RS232C RS422/485(2wire) RS422/485(4wire)

Speed

Data Length 7 8

Parity NONE EVEN ODD

Stop Bit 1 2

Flow Control NONE ER(DTR/CTS) XON/XOFF

Timeout (sec)

Retry

Wait To Send (ms)

RI / VCC RI VCC

In the case of RS232C, you can select the 9th pin to RI (Input) or VCC (5V Power Supply). If you use the Digital's RS232C Isolation Unit, please select it to VCC.

Device-Specific Settings

Allowable Number of Devices/PLCs 16

Number	Device Name	Settings
1	PLC1	Slave Address=1

Setup Items	Setup Description
SIO Type	Select the SIO type to communicate with the External Device.
Speed	Select speed between the External Device and the Display.
Data Length	Display data length.
Parity	Select how to check parity.
Stop Bit	Select stop bit length.
Flow Control	Select the communication control method to prevent overflow of transmission and reception data.
Timeout	Use an integer from 1 to 127 to enter the time (s) for which the Display waits for the response from the External Device.
Retry	In case of no response from the External Device, use an integer from 0 to 255 to enter how many times the Display retransmits the command.
Wait To Send	Use an integer from 0 to 255 to enter standby time (ms) for the Display from receiving packets to transmitting next commands.
RI/VCC	You can switch RI/VCC of the 9th pin when you select RS232C for SIO type. It is necessary to change RI/5V by changeover switch of IPC when connect with IPC. Please refer to the manual of the IPC for more detail.

■ Device Setting

To display the setting screen, click  ([Setting]) of External Device you want to set from [Device-Specific Settings] of [Device/PLC Settings].

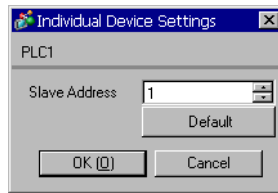

Setup Items	Setup Description
Slave Address	Use an integer from 1 to 247 to enter the address of the External Device.

4.2 Setup Items in Off-Line Mode

NOTE

- Refer to the Maintenance/Troubleshooting manual for information on how to enter off-line mode or about the operation.

Cf. Maintenance/Troubleshooting Manual "2.2 Off-line Mode"

■ Communication Settings

To display the setting screen, touch [Device/PLC Settings] from [Peripheral Settings] in off-line mode. Touch the External Device you want to set from the displayed list.

Comm.	Device	Option		
Hi4 Robot			[COM1]	Page 1/1
SIO Type		RS232C		
Speed		38400		
Data Length		8		
Parity		<input checked="" type="radio"/> NONE <input type="radio"/> EVEN <input type="radio"/> ODD		
Stop Bit		<input checked="" type="radio"/> 1 <input type="radio"/> 2		
Flow Control		NONE		
Timeout(s)		3	▼ ▲	
Retry		2	▼ ▲	
Wait To Send(ms)		8	▼ ▲	
	Exit		Back	2007/11/01 16:44:41

Setup Items	Setup Description
SIO Type	Select the SIO type to communicate with the External Device. IMPORTANT To make the communication settings correctly, confirm the serial interface specifications of Display unit for [SIO Type]. We cannot guarantee the operation if a communication type that the serial interface does not support is specified. For details concerning the serial interface specifications, refer to the manual for Display unit.
Speed	Select speed between the External Device and the Display.
Data Length	Display data length.
Parity	Select how to check parity.
Stop Bit	Select stop bit length.
Flow Control	Select the communication control method to prevent overflow of transmission and reception data.
Timeout (s)	Use an integer from 1 to 127 to enter the time (s) for which the Display waits for the response from the External Device.

Continues to the next page.

Setup Items	Setup Description
Retry	In case of no response from the External Device, use an integer from 0 to 255 to enter how many times the Display retransmits the command.
Wait To Send (ms)	Use an integer from 0 to 255 to enter standby time (ms) for the Display from receiving packets to transmitting next commands.

■ Device Settings

To display the setting screen, touch [Device/PLC Settings] from [Peripheral Equipment Settings]. Touch the External Device you want to set from the displayed list, and touch [Device Settings].

Setup Items	Setup Description
Device/PLC name	Select the External Device to set. Device name is a title of the External Device set with GP-Pro EX. (Initial value [PLC1])
Slave Address	Use an integer from 1 to 247 to enter the address of the External Device.

■ Option

To display the setting screen, touch [Device/PLC Settings] from [Peripheral Equipment Settings]. Touch the External Device you want to set from the displayed list, and touch [Option].

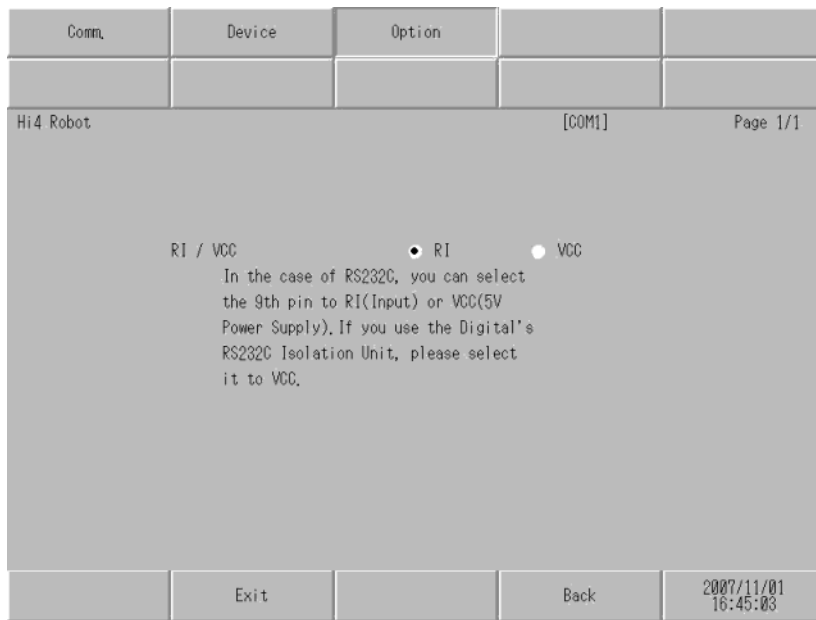

Setup Items	Setup Description
RI/VCC	Switches RI/VCC of the 9th pin. It is necessary to change RI/5V by changeover switch of IPC when connect with IPC. Please refer to the manual of the IPC for more detail.

5 Cable Diagram

The cable diagram shown below may be different from the cable diagram recommended by Hyundai Heavy Industries. Please be assured there is no operational problem in applying the cable diagram shown in this manual.

- The FG pin of the External Device body must be D-class grounded. Please refer to the manual of the External Device for more details.
- SG and FG are connected inside the Display. When connecting SG to the External Device, design the system not to form short-circuit loop.
- Connect the isolation unit, when communication is not stabilized under the influence of a noise etc.

Cable Diagram 1

Display (Connection Port)	Cable	Notes
GP (COM1) ST (COM1) LT (COM1) IPC*1 PC/AT	Your own cable	Cable length: 15m or less

*1 Only the COM port which can communicate by RS-232C can be used.

 "■ COM Port of IPC" (page 4)

When using your own cable

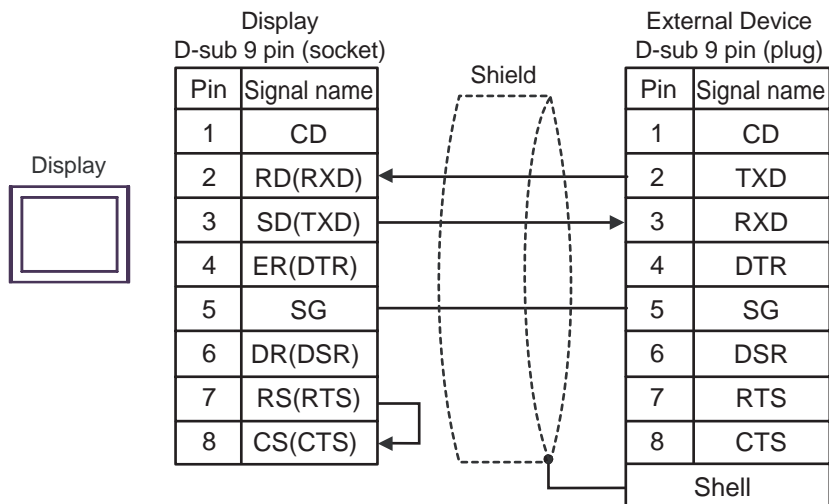

Cable Diagram 2

Display (Connection Port)	Cable	Notes
GP (COM1) ST (COM1) LT (COM1) IPC*1 PC/AT	Your own cable	Cable length: 15m or less

*1 Only the COM port which can communicate by RS-232C can be used.
 "■ COM Port of IPC" (page 4)

When using your own cable

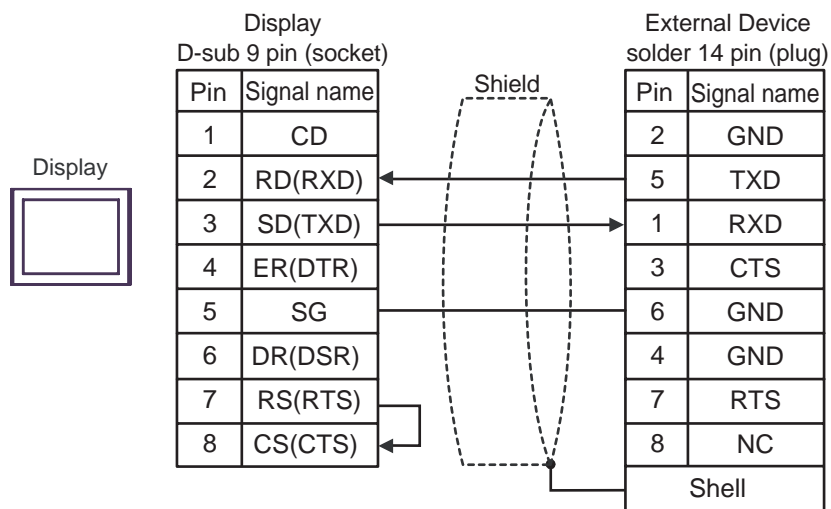

Cable Diagram 3

Display (Connection Port)	Cable		Notes
GP* ¹ (COM1) AGP-3302B (COM2) ST* ² (COM2) LT (COM1) IPC* ³	A	COM port conversion adapter by Pro-face CA3-ADPCOM-01 + Terminal block conversion adapter by Pro-face CA3-ADPTRM-01 + Your own cable	Cable length: 500m or less
	B	Your own cable	
GP* ⁴ (COM2)	C	Online adapter by Pro-face CA4-ADPONL-01 + Terminal block conversion adapter by Pro-face CA3-ADPTRM-01 + Your own cable	
	D	Online adapter by Pro-face CA4-ADPONL-01 + Your own cable	

*1 All GP models except AGP-3302B

*2 All ST models except AST-3211A

*3 Only the COM port which can communicate by RS-422/485 (4 wire) can be used.

☞ "■ COM Port of IPC" (page 4)

*4 All GP models except GP-3200 series and AGP-3302B

A) When using the COM port conversion adapter (CA3-ADPCOM-01), the terminal block conversion adapter (CA3-ADPTRM-01) by Pro-face and your own cable

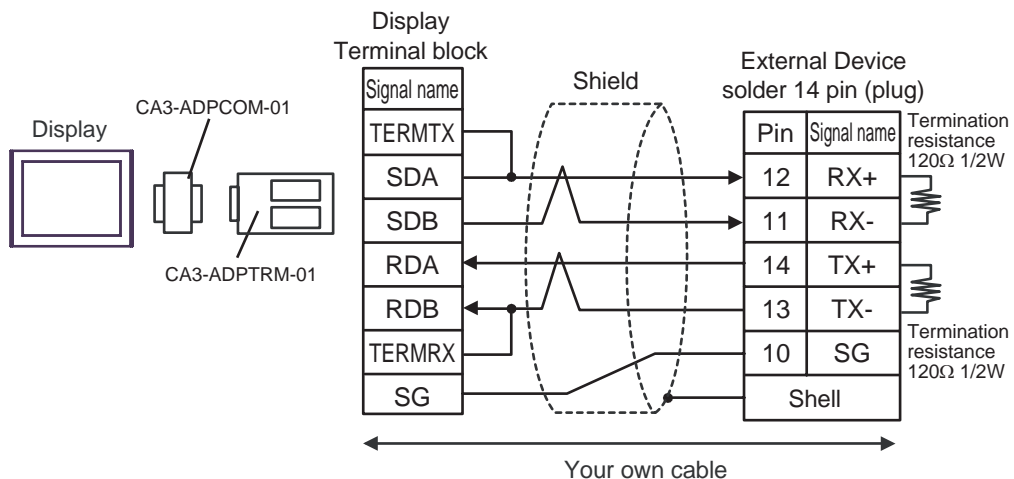

B) When using your own cable

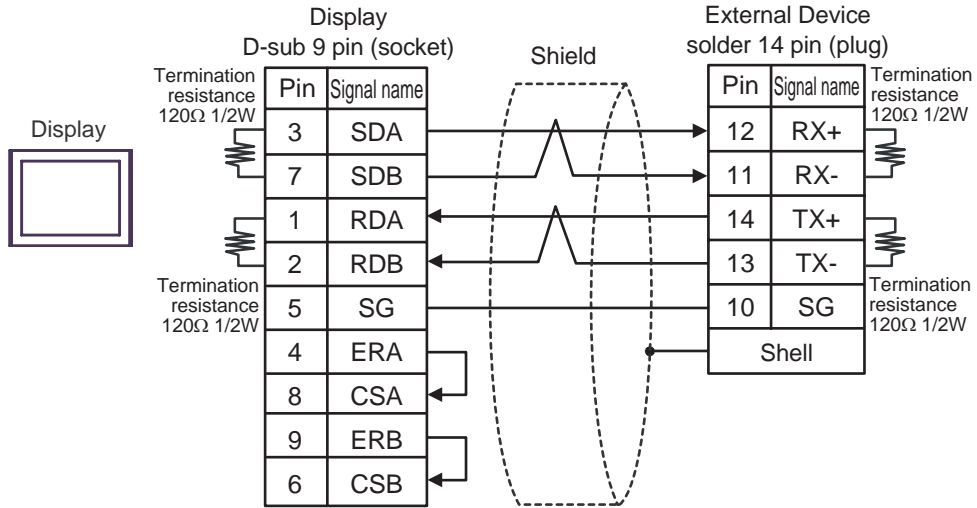

C) When using the online adapter (CA4-ADPONL-01), the terminal block conversion adapter (CA3-ADPTRM-01) by Pro-face and your own cable

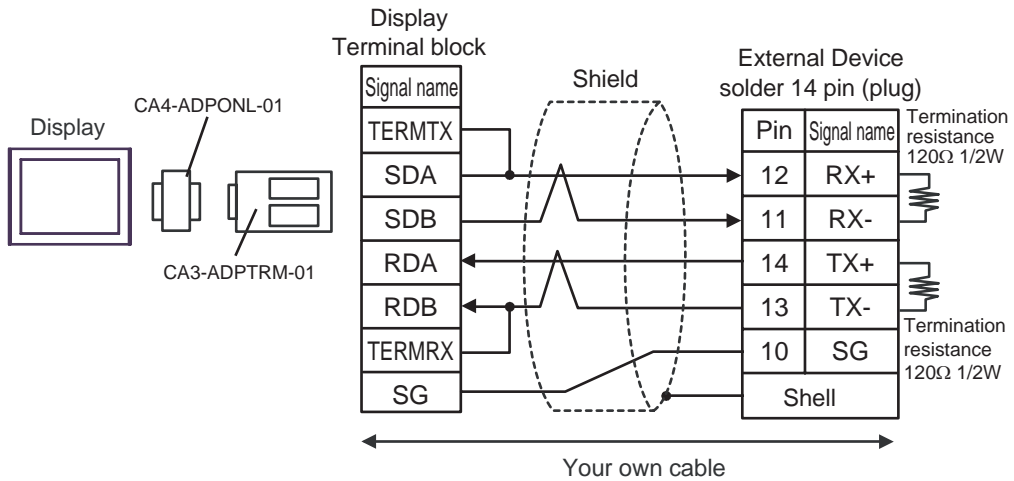

D) When using the online adapter (CA4-ADPONL-01) by Pro-face and your own cable

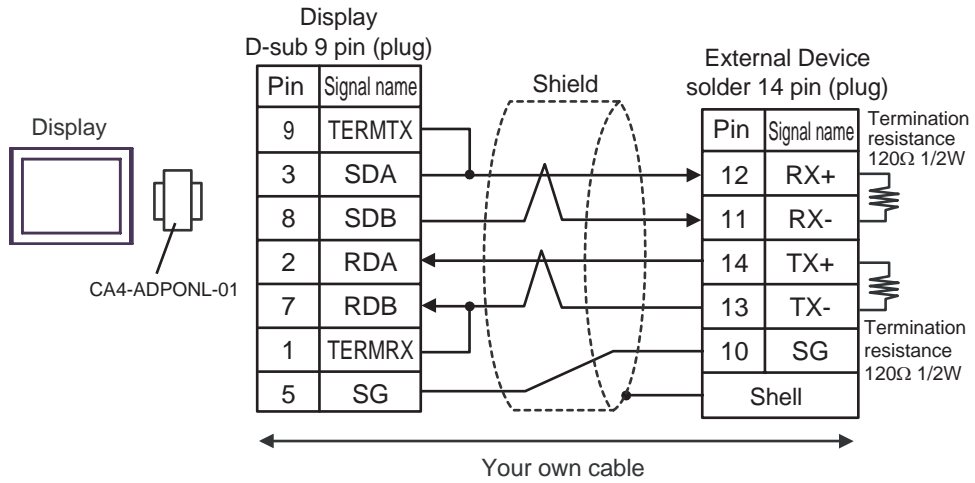

6 Supported Device

Range of supported device address is shown in the table below.

 This address can be specified as system data area.

Device	Bit Address	Word Address	32bits	Notes
External Input	X001 - X256	XW01 - XW16	H/L	*1, *2
PLC Input	DO001 - DO256	DOW01 - DOW16		*1, *2
Fieldbus Input #1	FB1.X001 - FB1.X960	FB1.XW01 - FB1.XW60		*1, *2
Fieldbus Input #2	FB2.X001 - FB2.X960	FB2.XW01 - FB2.XW60		*1, *2
Fieldbus Input #3	FB3.X001 - FB3.X960	FB3.XW01 - FB3.XW60		*1, *2
Fieldbus Input #4	FB4.X001 - FB4.X960	FB4.XW01 - FB4.XW60		*1, *2
Timer(Contact)	T001 - T256	-		*1, *2
Counter(Contact)	C001 - C256	-		*1, *2
Analog Input	-	AI1 - AI4		*2, *3, *4
External Output	Y001 - Y256	YW01 - YW16		*1
PLC Output	DI001 - DI256	DIW01 - DIW16		*1
Fieldbus Output #1	FB1.Y001 - FB1.Y960	FB1.YW01 - FB1.YW60		*1
Fieldbus Output #2	FB2.Y001 - FB2.Y960	FB2.YW01 - FB2.YW60		*1
Fieldbus Output #3	FB3.Y001 - FB3.Y960	FB3.YW01 - FB3.YW60		*1
Fieldbus Output #4	FB4.Y001 - FB4.Y960	FB4.YW01 - FB4.YW60		*1
Special	SP01 - SP32	SPW1 - SPW2		*1
Auxiliary	R0001 - R1024	RW01 - RW64		*1
Keep	K0001 - K1024	KW01 - KW64		*1
Timer(Current Value)	-	TW001 - TW256		*1
Counter(Current Value)	-	CW001 - CW256		*1
Analog Output	-	AO1 - AO4		*3, *4
System Memory	-	SW001 -SW256		Bit 15 *1
Shared Register	-	MW0001 - MW5000		Bit 15 *1
HRBASIC V% Variable	-	V%001 - V%400		*1
RN Register for M-code	-	RN01 - RN16		*1
HRBASIC V\$ Variable	-	V\$01.00 - V\$40.17		*5, *6
HRBASIC V! Variable	-	V!001 - V!400		*4, *7

*1 Writing is enabled when ROM version of External Device is Hi4 ROM version 2007.01.26 or higher.

*2 Write disable

*3 AI/AO device uses real number of 12 bit of Hi4 Robot.

Data range is between -12.000 and +12.000, but figure between -12000 and 12000 is used on Display.

- *4 Can be used when ROM version of External Device in use is Hi4 ROM version 2007.02.06 or higher.
- *5 Writing cannot be executed when ROM version of External Device in use is Hi4 ROM version 2007.02.06 or lower.
- *6 Since the size of the HRBASIC V\$ variable is equivalent to 18 words, the HRBASIC V\$ variable is treated as an aggregate of 18 points of a 1 word device in the GP-Pro EX. When specifying the address in the GP-Pro EX, the device address in the word order is displayed.

V\$01.00

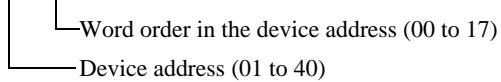

- *7 HRBASIC V! is a 32bit floating point.

NOTE

- Please refer to the GP-Pro EX Reference Manual for system data area.
Cf. GP-Pro EX Reference Manual "Appendix 1.4 LS Area (Direct Access Method)"
 - Please refer to the precautions on manual notation for icons in the table.
 "Manual Symbols and Terminology"
-

7 Device Code and Address Code

Use device code and address code when you select "Device Type & Address" for the address type in data displays.

Device	Device Name	Device Code (HEX)	Address Code
External Input	X / XW	0080	Word Address
PLC Input	DO / DOW	0082	Word Address
Fieldbus Input #1	FB1.X / FB1.XW	0083	Word Address
Fieldbus Input #2	FB2.X / FB2.XW	0084	Word Address
Fieldbus Input #3	FB3.X / FB3.XW	0085	Word Address
Fieldbus Input #4	FB4.X / FB4.XW	0086	Word Address
Analog Input	AI	0066	Word Address
External Output	Y / YW	0081	Word Address
PLC Output	DI / DIW	0087	Word Address
Fieldbus Output #1	FB1.Y / FB1.YW	0088	Word Address
Fieldbus Output #2	FB2.Y / FB2.YW	0089	Word Address
Fieldbus Output #3	FB3.Y / FB3.YW	008A	Word Address
Fieldbus Output #4	FB4.Y / FB4.YW	008B	Word Address
Special	SP / SPW	008C	Word Address
Auxiliary	R / RW	008D	Word Address
Keep	K / KW	008E	Word Address
Timer(Current Value)	TW	0060	Word Address
Counter(Current Value)	CW	0061	Word Address
Analog Output	AO	0067	Word Address
System Memory	SW	0001	Word Address
Shared Register	MW	0000	Word Address
HRBASIC V% Variable	V%	0062	Word Address
RN Register for M-code	RN	0063	Word Address
HRBASIC V\$ Variable	V\$	0064	Word Address
HRBASIC V! Variable	V!	0065	Word Address

8 Error Messages

Error messages are displayed on the screen of Display as follows: "No. : Device Name: Error Message (Error Occurrence Area)". Each description is shown below.

Item	Description
No.	Error No.
Device Name	Name of External Device where error occurs. Device name is a title of External Device set with GP-Pro EX. (Initial value [PLC1])
Error Message	Displays messages related to the error which occurs.
Error Occurrence Area	<p>Displays IP address or device address of External Device where error occurs, or error codes received from External Device.</p> <p>NOTE</p> <ul style="list-style-type: none"> • IP address is displayed such as "IP address (Decimal): MAC address (Hex)". • Device address is displayed such as "Address: Device address". • Received error codes are displayed such as "Decimal [Hex]".

Display Examples of Error Messages

"RHAA035:PLC1: Error has been responded for device write command (Error Code: 2 [02H])"

NOTE

- Refer to your External Device manual for details on received error codes.
- Refer to "When an error is displayed (Error Code List)" in "Maintenance/Troubleshooting Manual" for details on the error messages common to the driver.

■ Error Codes Unique to External Device

Error codes unique to External Device are shown below.

Error Code	Description
02H	Illegal data address.
03H	Illegal data value.