

# 23



# Time Schedule

This chapter explains about the “Time Schedule” in GP-Pro EX and basic operations used to set the Time Schedule function.

Please start by reading “23.1 Settings Menu” (page 23-2) and then turn to the corresponding page.

23.1	Settings Menu .....	23-2
23.2	Turning ON/OFF a Motor at the Designated Time .....	23-3
23.3	Changing the Temperature at the Designated Time .....	23-6
23.4	Common Settings Guide (Time Schedule Settings).....	23-10
23.5	Restrictions .....	23-20

## 23.1 Settings Menu

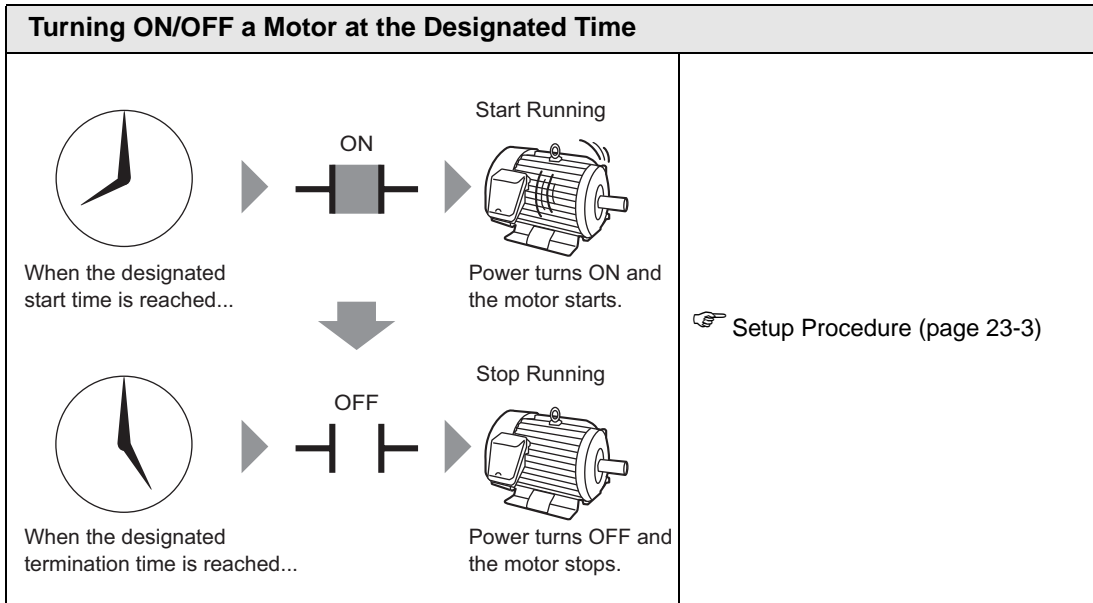

☞ Setup Procedure (page 23-3)

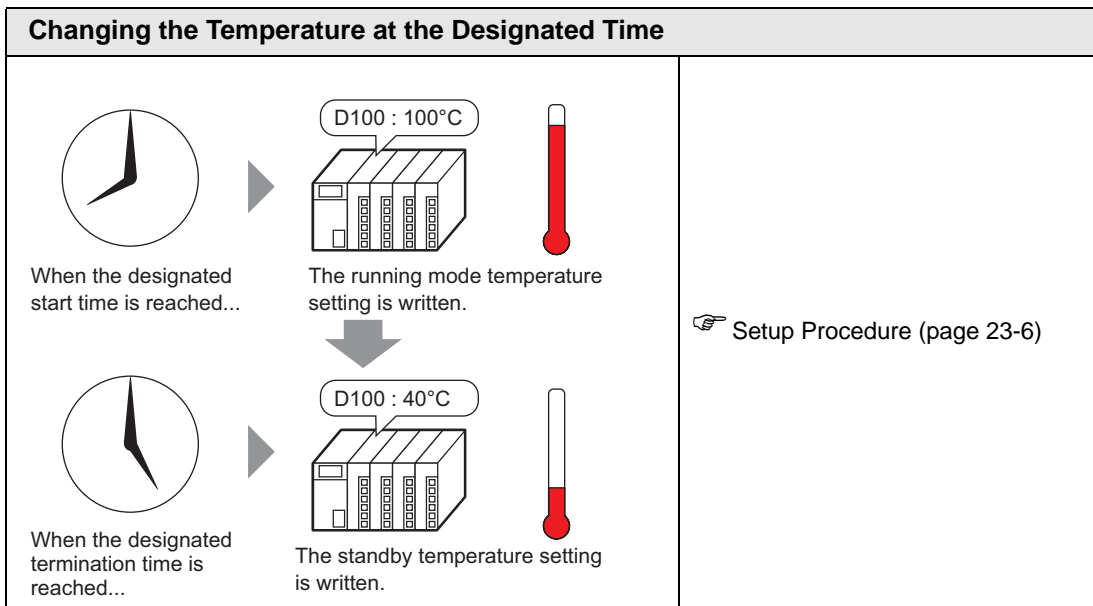

☞ Setup Procedure (page 23-6)

## 23.2 Turning ON/OFF a Motor at the Designated Time

### 23.2.1 Setup Procedure

**NOTE** • Please refer to the settings guide for details.  
 ☞ “23.4 Common Settings Guide (Time Schedule Settings)” (page 23-10)

The motor’s power (M100) is run from Monday to Friday, 8:00 to 17:00. Here is the setting procedure for turning ON the bit address M100 at the start time (8:00) and OFF at the end time (17:00).

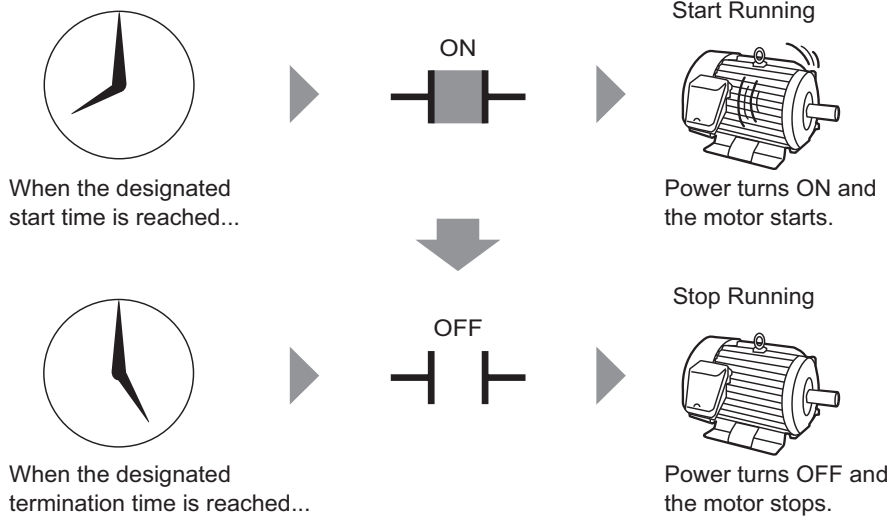

1 Select the [Common Settings (R)] menu - [Time Schedule Settings (F)] command, or click  from the toolbar. The Time Schedule Settings screen will appear.

No.	Mode	Action Address	Time Type	Time Setting Address	Start Time	End Time	Day	Write Mode	Write Start Value	Write End Value
1										
2										
3										
4										
5										
6										
7										
8										
9										
10										
11										
12										
13										
14										
15										
16										
17										
18										
19										
20										
21										
22										
23										
24										
25										
26										
27										

- 2 Select the row of the schedule number you want to register (e.g.: No. 1), and double-click it. The settings dialog box opens.

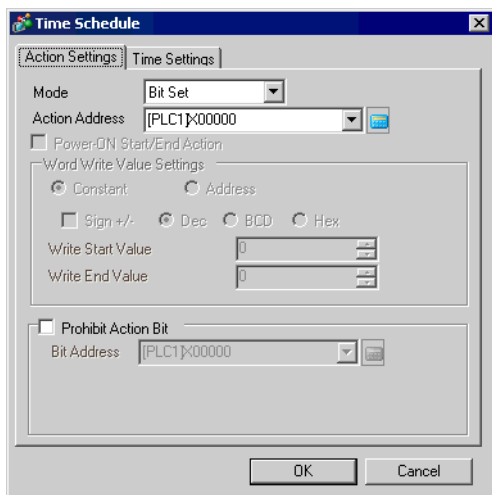

**NOTE** • You can register up to 32 schedules (No. 1 to No. 32) in the schedule function.

- 3 Choose [Bit Set] from [Mode].

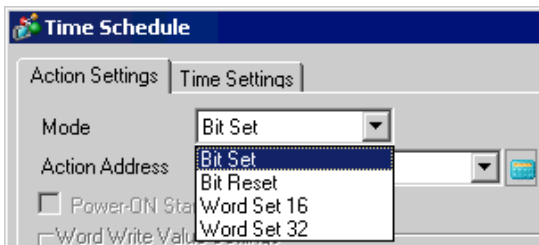

- 4 Designate the target bit address (e.g.: M100) in [Action Address].

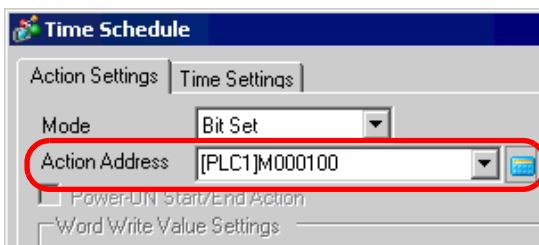

5 Open the [Time Settings] tab and select [Constant].

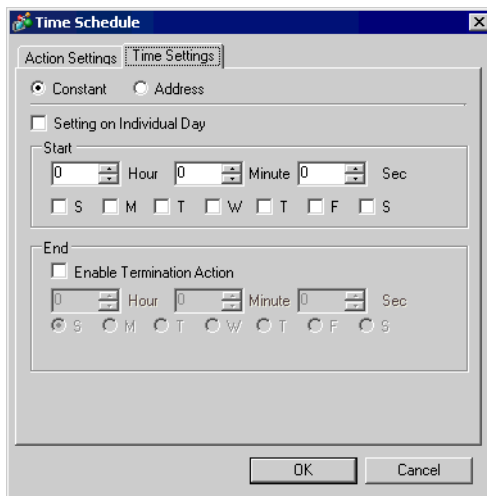

6 Set the start time and day. Set the start time as 8:00, and put a check mark next to the boxes from Monday to Friday. Leave [Setting on Individual Day] blank.

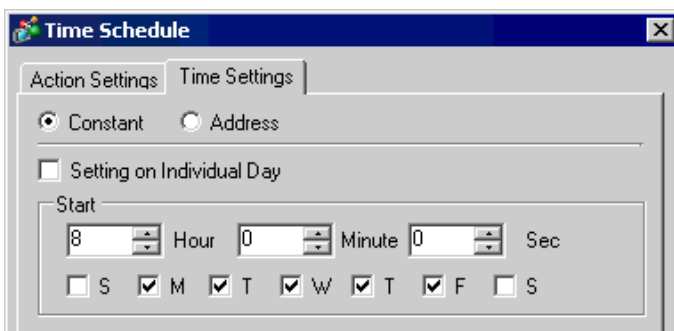

7 Set the end time. Put a check mark next to [Enable Termination Action] and set the end time as 17:00.

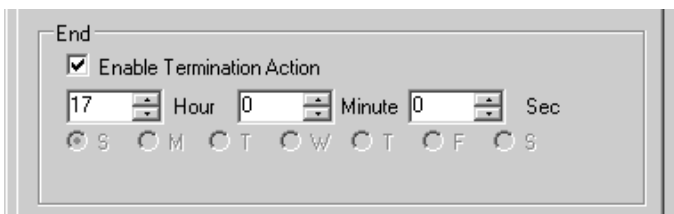

8 Click [OK] and the dialog box closes. The set content appears in the Schedule Settings screen.

No.	Mode	Action Address	Time Type	Time Setting Address	Start Time	End Time	Day	Write M
1	Bit Set	[PLC1]M000100	Constant	.....	08:00:00	17:00:00	Mon,Tue,Wed,Thu, .....	
2								
3								

## 23.3 Changing the Temperature at the Designated Time

### 23.3.1 Setup Procedure

**NOTE** • Please refer to the settings guide for details.  
 “23.4 Common Settings Guide (Time Schedule Settings)” (page 23-10)

Writes the designated temperature data to the word address (D100) which will store the set temperature. Here is the setting procedure for setting the temperature. From Monday to Friday, a temperature setting of 100 is written to D100 at the start time (8:00) for the running mode, and a temperature setting of 40 is written at the end time (17:00) for standby mode.

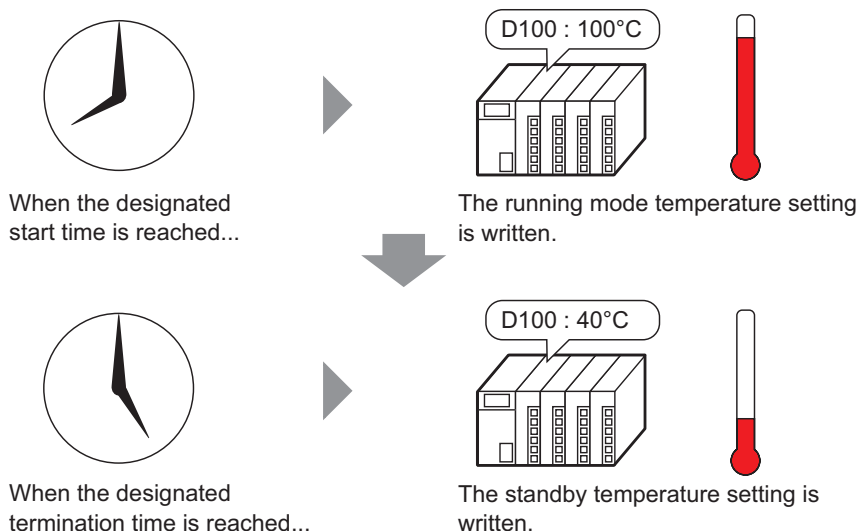

- 1 Select the [Common Settings (R)] menu - [Time Schedule Settings (F)] command, or click  from the toolbar. The Time Schedule Settings screen will appear.

No.	Mode	Action Address	Time Type	Time Setting Address	Start Time	End Time	Day	Write Mode	Write Start Value	Write End Value
1										
2										
3										
4										
5										
6										
7										
8										
9										
10										
11										
12										
13										
14										
15										
16										
17										
18										
19										
20										
21										
22										
23										
24										
25										
26										
27										

- 2 Select the row of the schedule number you want to register (e.g.: No. 1), and double-click it. The settings dialog box opens.

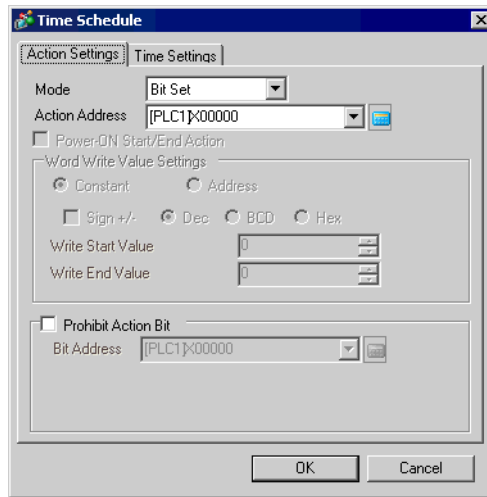

**NOTE** • You can register up to 32 schedules (No. 1 to No. 32) in the schedule function.

- 3 Choose [Word Set 16] from [Mode].

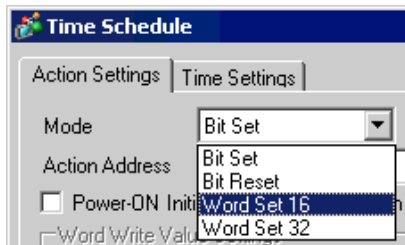

- 4 Designate the target word address (e.g.: D100) in [Action Address].

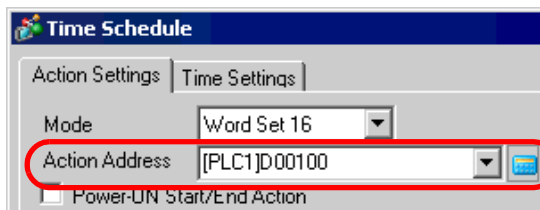

5 Select [Constant] and set the [Write Start Value] to “100”.

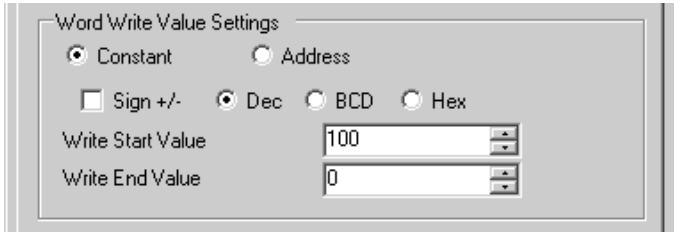

6 Open the [Time Settings] tab and select [Constant].

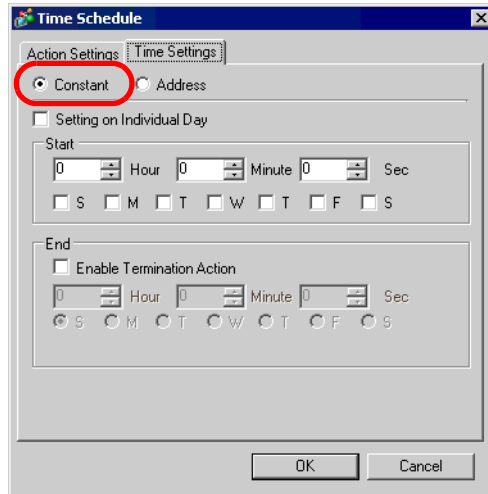

7 Set the start time and day. Set the start time as 8:00, and put a check mark next to the boxes from Monday to Friday. Leave [Setting on Individual Day] blank.

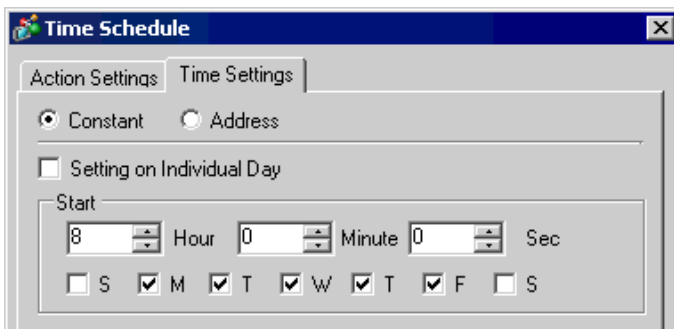

8 Set the end time. Put a check mark next to [Enable Termination Action] and set the end time as 17:00.

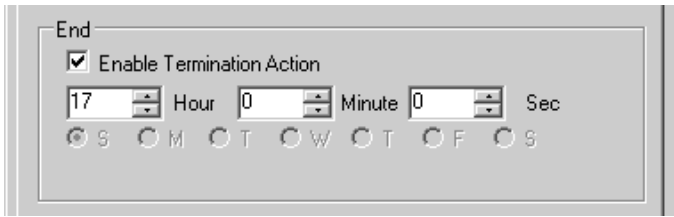

9 Open the [Action Settings] tab and set the [Write End Value] to “40”.

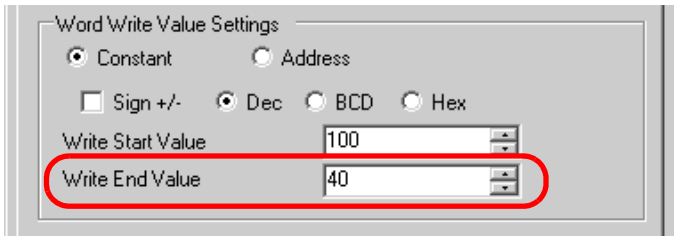

10 Click [OK] and the dialog box closes. The set content appears in the Schedule Settings screen.

Time Schedule Settings										
No.	Mode	Action Address	Time Type	Time Setting Address	Start Time	End Time	Day	Write Mode	Write Start Value	Write End Value
1	Word Set 16	[PLC1]D00000	Constant	-----	08:00:00	17:00:00	Mon,Tue,Wed,Thu,	Dec	100	40
2										
3										

## 23.4 Common Settings Guide (Time Schedule Settings)

### 23.4.1 Time Schedule Settings Screen

In the following [Time Schedule] dialog box, you can check the settings of all the time schedules in a list. Up to 32 time schedule functions can be registered in each project.

The [Time Schedule] dialog box is displayed by double-clicking on one of the rows from No. 1 to No. 32.

No.	Mode	Action Address	Time Type	Time Setting Address	Start Time	End Time	Day	Write Mode	Write Start Value	Write End Value
1										
2										
3										
4										
5										
6										
7										
8										
9										
10										
11										
12										
13										
14										
15										
16										
17										
18										
19										
20										
21										
22										
23										
24										
25										
26										
27										

### 23.4.2 [Time Schedule] Dialog Box Settings Guide

#### ■ Action Settings

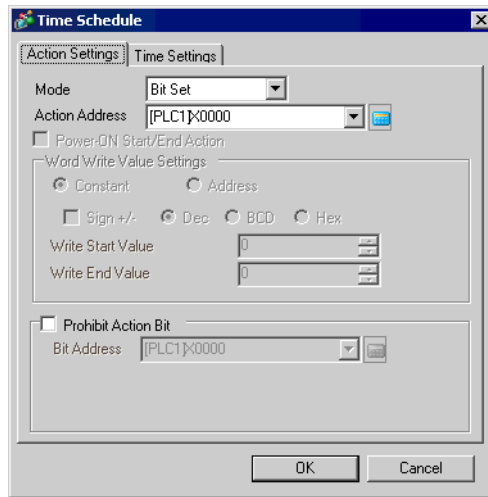

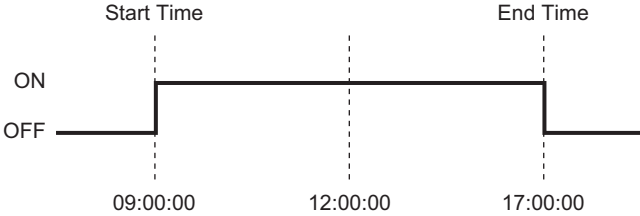
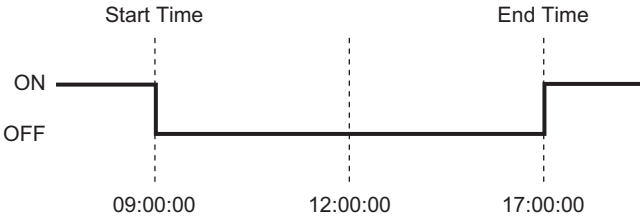
Setting	Description
<p>Mode</p>	<p>Specify which type of action will be used for the designated time. Choose from [Bit Set], [Bit Reset], [Word Set 16], or [Word Set 32].</p>
<p>Bit Set</p>	<p>When the Start Time arrives, the specified bit turns ON. When the End Time arrives, the bit turns OFF.                      (Action Example)                      Start Time: 09:00:00                      End Time: 17:00:00</p> 
<p>Bit Reset</p>	<p>When the Start Time arrives, the specified bit turns OFF. When the End Time arrives, the bit turns ON.                      (Action Example)                      Start Time: 09:00:00                      End Time: 17:00:00</p> 

Continued

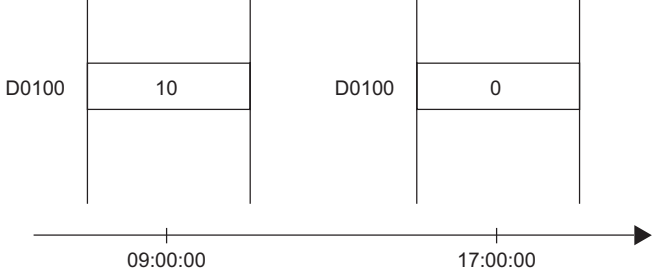
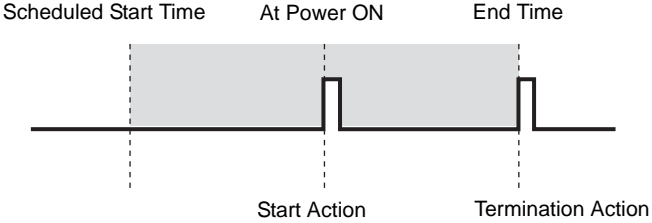
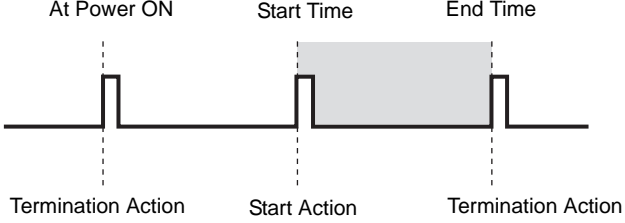
Setting		Description
Mode	Word Set 16	<p>When the Start Time arrives, the specified [Write Start Value] is written to the word address. When the End Time arrives, the [Write End Value] is written.</p> <p>(Action Example)</p> <p>Device Address : D0100                      Start Value : 10                      End Value : 0                      Start Time : 09:00:00                      End Time : 17:00:00</p> 
	Word Set 32	
Action Address		Designate the address used to control the schedule.
Power-ON Start/End Action	<p>Select the action to perform when power is turned on.</p> <ul style="list-style-type: none"> <li>• When Enabled                             <p>If the GP unit's power is turned ON during (inside) the scheduled range, the initiation action will be automatically performed. If the GP unit's power is turned ON outside of the scheduled range, the termination action will be automatically performed.</p> <p>&lt;Inside the scheduled range&gt;</p>  <p>&lt;Outside the scheduled range&gt;</p>  </li> </ul>	
	<ul style="list-style-type: none"> <li>• When Disabled                             <p>If power is turned ON but the start time has already been passed, the initiation action is not automatically performed. However, the termination action will automatically be performed.</p> <p>Also, if the termination action is not set, the schedule range is not recognized and the action will not be performed.</p> </li> </ul>	

Continued

Setting	Description
Word Write Value Settings	These settings are active only when the Mode is set to [Word Set 16] or [Word Set 32].
Constant/Address	Select the method to set the [Write Start Value] and [Write End Value]. <ul style="list-style-type: none"> <li>• Constant Write and designate a set constant.</li> <li>• Address Set the address that stores the value. You can change the [Write Start Value] and [Write End Value] by changing the value to store.</li> </ul>
Sign +/-	If you have selected [Constant], specify whether or not to handle negative values.
Dec/BCD/Hex	If you have selected [Constant], select the data format of [Write Start Value] and [Write End Value].
Write Start Value	<ul style="list-style-type: none"> <li>• For [Constant] Designates the value of the start time.</li> <li>• For [Address] Designates the address used to store the start time value.</li> </ul>
Write End Value	<ul style="list-style-type: none"> <li>• For [Constant] Designates the value of the end time.</li> <li>• For [Address] Designates the address used to store the end time value.</li> </ul> <p><b>NOTE</b></p> <ul style="list-style-type: none"> <li>• If [Enable Termination Action] is selected on the [Time Settings] tab, this can be set.</li> </ul>
Prohibit Action Bit	Select whether or not to prohibit the schedule function. When this feature is selected, at the beginning of the schedule, the designated value will be read out from the [Action Inhibit Bit]'s address. If the [Action Inhibit Bit] is ON, the schedule action is not performed.
Bit Address	Choose an address for the [Action Inhibit Bit].

The settings range for [Write Start Value] and [Write End Value] differs depending on the specified data format and Sign +/-.

Mode	Data Type	Sign +/-	Setting Range
Word Set 16	Dec	Unchecked	0 to 65,535
		Checked	-32,768 to 32,767
	BCD	—	0 to 9,999
	Hex	—	0 to FFFF
Word Set 32	Dec	Unchecked	0 to 4,294,967,295
		Checked	-2,147,483,648 to 2,147,483,647
	BCD	—	0 to 99,999,999
	Hex	—	0 to FFFFFFFF

■ Time Settings (When Constant is selected)

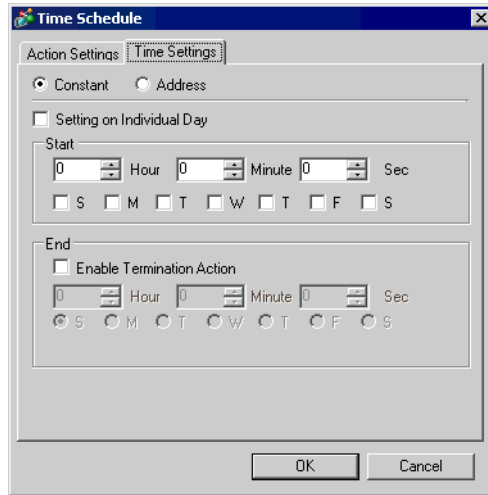

Setting	Description
Constant/Address	<p>Select the method to set the Start Time and End Time.</p> <ul style="list-style-type: none"> <li>• Constant Specifies a fixed time and day.</li> <li>• Address Specifies the address which stores the data for the time and day. You can change the time and day by changing the data to store.</li> </ul>
Setting on Individual Day	<ul style="list-style-type: none"> <li>• When Enabled Can be set if the Time Schedule spans 2 or more days. Only one Start Day and End Day can be set.</li> </ul> <div style="text-align: center;"> </div> <p><b>NOTE</b></p> <ul style="list-style-type: none"> <li>• You must enter settings for the Start Time and End Time.</li> <li>• You cannot set the Start Time and End Time to the exact same day and time.</li> </ul>

Continued

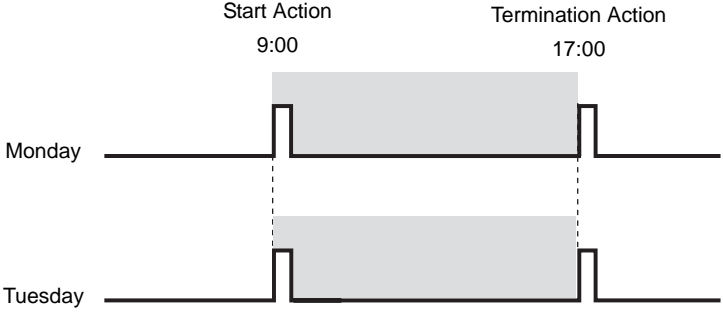
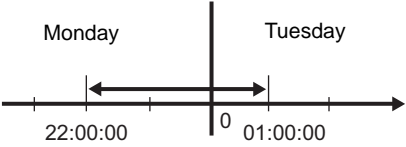
Setting	Description
<p>Setting on Individual Day</p>	<ul style="list-style-type: none"> <li>When Disabled A schedule that is 1 day (Start and End times are within 24 hours) can be entered. Multiple Start and End days can be selected. You can perform actions at the same time on multiple days. When specifying an End Time, enable [Enable Termination Action].</li> </ul> <div style="text-align: center;">  <p>Start Action 9:00 Termination Action 17:00</p> <p>Monday</p> <p>Tuesday</p> </div> <p><b>NOTE</b></p> <ul style="list-style-type: none"> <li>You cannot set the Start Time and End Time to the exact same time.</li> <li>The Time Schedule (shown below) is for one day only, so if the End time is entered as being before the Start time, the End time will be performed on the next day.</li> </ul> <p>(e.g.) Start Day: Monday Start Time: 22:00:00 End Time: 01:00:00</p> <div style="text-align: center;">  <p>Monday Tuesday</p> <p>22:00:00 0 01:00:00</p> </div>
<p>Start</p>	<p>Choose the start time and day. When [Setting on Individual Day] is disabled, you must specify more than one day.</p>
<p>End</p>	<p>When [Enable Termination Action] is enabled, the End time can be specified. The day settings can only be set when [Setting on Individual Day] is enabled.</p>

■ Time Settings (When Address is selected)

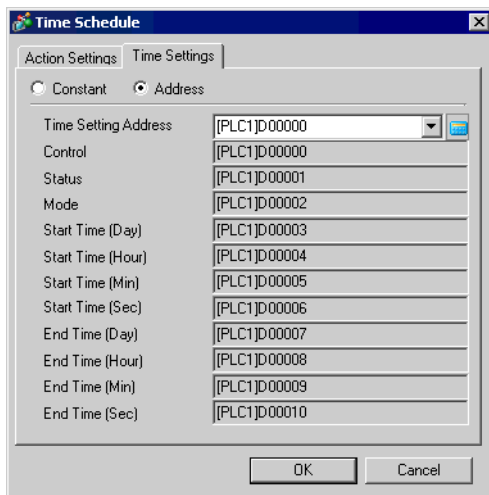

Setting	Description
Time Setting Address	Designates the top address used to store time settings data read out from a device/PLC. The following 10 word addresses are automatically allotted.
Control	Reads out the Mode, Start Time, and End Time. ☞ “◆ Control: Address (Time Setting Address +0)” (page 23-17)
Status	Turns a bit ON after the [Control] time data readout is completed or if the time data entered is incorrect. ☞ “◆ Status (Time Setting Address +1)” (page 23-17)
Mode	Designates [Enable Termination Action] and [Setting on Individual Day]. ☞ “■ Time Settings (When Constant is selected)” (page 23-14) ☞ “◆ Mode (Time Setting Address +2)” (page 23-18)
Start Time (Day)	Designates the start day. ☞ “◆ Start/End Day (Start Day: Time Setting Address + 3, End Day: Time Setting Address + 7)” (page 23-19)
Start Time (Hour)	Designates the start time. ☞ “◆ Start/End Time: (Start Time: Time Setting Address +4 to +6, End Time: Time Setting Address +8 to +10)” (page 23-19)
Start Time (Min)	
Start Time (Sec)	
End Time (Day)	Designates the end day. ☞ “◆ Start/End Day (Start Day: Time Setting Address + 3, End Day: Time Setting Address + 7)” (page 23-19)
End Time (Hour)	Designates the end time. ☞ “◆ Start/End Time: (Start Time: Time Setting Address +4 to +6, End Time: Time Setting Address +8 to +10)” (page 23-19)
End Time (Min)	
End Time (Sec)	

◆ **Control: Address (Time Setting Address +0)**

When the Time Acquisition Request bit's ON (0 to 1) is detected, the Mode, Start Time, and End Time are read out.

15	01	00	Bit
Reserved (0 Fixed)			0

Bit 00 : Time Acquisition Request Bit (0: No action, 1: Perform Time Read)

- NOTE** • Data is not read out regularly from the Time Setting Address mode (address + 2) to the End Time (Sec) (address + 10). When reflecting Time Settings data changes in the GP unit, be sure to turn ON (0 to 1) the Control's (address + 0) Time Acquisition Request Bit.

◆ **Status (Time Setting Address +1)**

After the Control's time data readout is completed, the GP unit will turn the Time Acquisition Completion Bit ON (0 to 1). Also, if the entered time data is incorrect, the Error Notification Bit will simultaneously turn ON (0 to 1).

15	02	01	00	Bit
Reserved (0 Fixed)			0	0

Bit 00: Time Acquisition Completion Bit (0: Either Time Acquisition is being performed or had not yet been performed, 1: Time Data Acquisition Completed)

Bit 01: Error Notification Bit (0: Time data is being replaced with correct data. 1: Time data contains an error.)

- NOTE** • Once the Time Acquisition Completion bit's rise (trigger) is recognized by the Device/PLC, be sure to turn the control's Time Acquisition Request bit OFF (1 to 0). Once this bit is turned OFF, the Status's Time Acquisition Completion bit and the Error Notification bit will automatically and simultaneously be turned OFF (1 to 0).

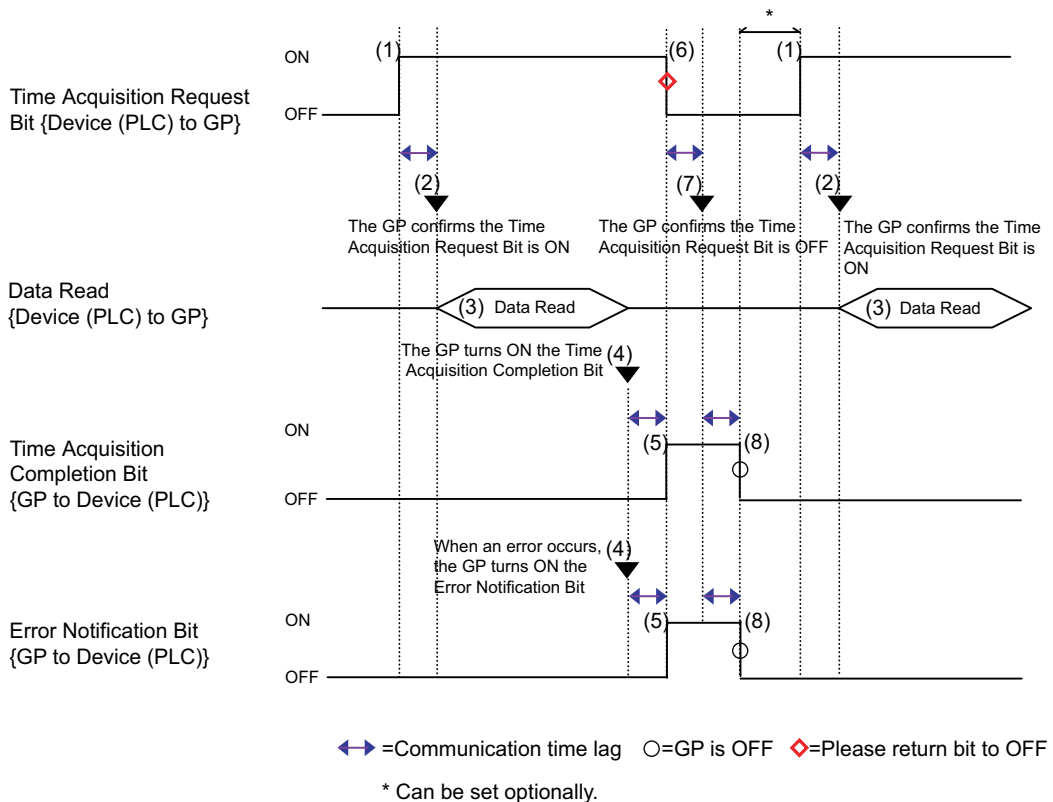

◆ **Mode (Time Setting Address +2)**

Select whether or not the Termination Time Action and the Individual Day settings are enabled/disabled. However, regardless of the Termination Time Action status (enabled/disabled), the indirectly designated time data (11 word addresses in the Time Setting Address) is all read out.

15	02	01	00	Bit
Reserved (0 Fixed)			0	0

Bit 00 : Termination Time Action Setting (0: None, 1: Used)  
 Bit 01 : Individual Day Specification Mode (0:None, 1: Used)

- NOTE**
- If a [0] (Not Used) is entered in the Individual Day Specification mode, the End Time (Day/Hour/Minute/Second) data will be read but it will be ignored.
  - If a [1] (Used) is entered in the Individual Day Specification mode, be sure to enter all Start and End time (Day/Hour/Minute/Second) information. However, if 2 or more of the Start/End Day bits turn ON simultaneously, an error will occur.

◆ **Start/End Day (Start Day: Time Setting Address + 3, End Day: Time Setting Address + 7)**

Designates the day used as a trigger for the Start/Termination Action.

15	07	06	05	04	03	02	01Bit	00
Reserved (0 Fixed)		Sat.	Fri.	Thu.	Wed.	Tues.	Mon.	Sun.

- Bit 00 : Sunday (0: None, 1: Designate)
- Bit 01 : Monday (0: None, 1: Designate)
- Bit 02 : Tuesday (0: None, 1: Designate)
- Bit 03 : Wednesday (0: None, 1: Designate)
- Bit 04 : Thursday (0: None, 1: Designate)
- Bit 05 : Friday (0: None, 1: Designate)
- Bit 06 : Saturday (0: None, 1: Designate)

◆ **Start/End Time: (Start Time: Time Setting Address +4 to +6, End Time: Time Setting Address +8 to +10)**

Set the time values used for the Start/Termination Actions in the following ranges.

Hour: 0 to 23

Min. : 0 to 59

Sec. : 0 to 59

If you specify a value outside of the range, an error will occur.

- NOTE**
- Time data is specified with binary input. It cannot be specified with BCD input.
  - The setting/not setting of the End Time will depend on the Mode (address +2) setting.

Also, the Termination Time Action setting (bit 00) available will depend on the Individual Day Specification mode (bit 01) used.

Individual Day Specification	Used	Not Used	
Termination Time Action Setting	Used	Used	Not Used

## 23.5 Restrictions

- You can register a maximum of 32 time schedules.
- The Time Schedule features are one-shot actions. In other words, when the Start time is reached, the designated device address is written to just once. The write action is not repeated.

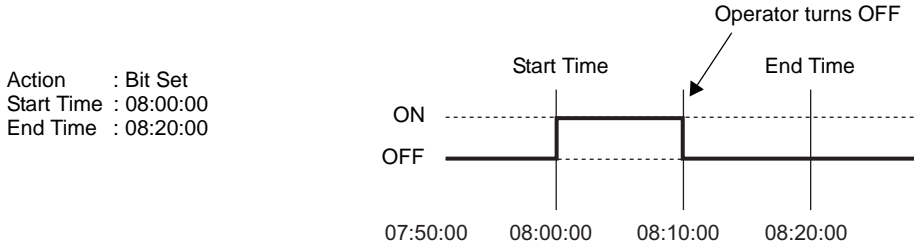

- The Word Write Value Settings' Write Start/End Value (for the address setting), and the Action Inhibit Bit monitoring are read only once, at the beginning of the Time Schedule. Since regular readout is not possible, there may be a slight data communication delay that causes the designated operation's Start Time to not be performed at exactly the Second setting entered.
- When changing GP Time Settings, the range of the schedule's start and end times is recognized. If the edited item is inside the scheduled range, the start action will be automatically performed. If the termination action is not set, the schedule's range cannot be confirmed and this feature will not be performed.
- If the Start Time Action is completed and then a power out occurs, the schedule's range will be recognized and the Termination Action will be performed at the End Time.

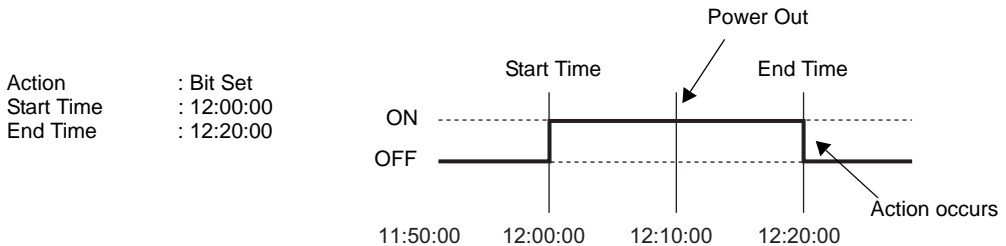

- When the same Start Times and End Times appear in multiple schedules, they will be handled in order, starting from the smallest schedule number.
- When the Time Settings are specified as Address, only the control address' data will be regularly read.

When there are multiple schedules with Time Settings specified as Address, there may be an effect on the GP's actions because each schedule's control address will be read regularly.

- When the Time Settings are specified as Address, control address' readout speed is once every 500ms.

When the Control Address bit 00 (Time Acquisition Request Bit) turns ON, a delay of up to 500ms may occur before the Status Address and onwards data is read out.

Also, when multiple schedules are set, if multiple control address' bit 00 (Time Acquisition Request Bits) simultaneously turn ON, in order to start operations in the set order, a delay may occur before an action is performed.

- When the Time Settings are specified as Address, the times may not function properly if you specify a Start Time or End Time that is outside the value range. Also, BCD input cannot be used.