

25 | Data Filing (Recipe)

This chapter explains about “Data Filing (Recipe)” in GP-Pro EX and the basic functions used to set Recipes.

Please start by reading “25.1 An Introduction to the Recipe Feature” (page 25-2) and then turn to the corresponding page.

25.1	An Introduction to the Recipe Feature	25-2
25.2	Settings Menu	25-6
25.3	Creating Recipes (CSV Data)	25-9
25.4	Transferring Recipes (CSV Data) by Touch	25-17
25.5	Transferring Recipes (CSV Data) from a Device/PLC	25-25
25.6	Displaying/Editing CSV Data on the Screen	25-30
25.7	Creating Recipes (Filing Data)	25-42
25.8	Transferring Recipes (Filing Data) by Touch (Manual Transfer)	25-46
25.9	Transferring Recipes (Filing Data) from a Device/PLC (Automatic Transfer)	25-52
25.10	Settings Guide.....	25-56
25.11	Transfer CSV Data Setup.....	25-88
25.12	Transfer Filing Data Setup	25-106
25.13	Restrictions	25-114

25.1 An Introduction to the Recipe Feature

25.1.1 What is the Recipe Feature?

This feature is used to create preset data (Recipes) you want to write to the device/PLC and then to do a mass rewrite of large number of data in the device/PLC by transferring the Recipe data.

These recipes can be used in process and production control as settings for machine operation (material quantities, heat settings, etc.)

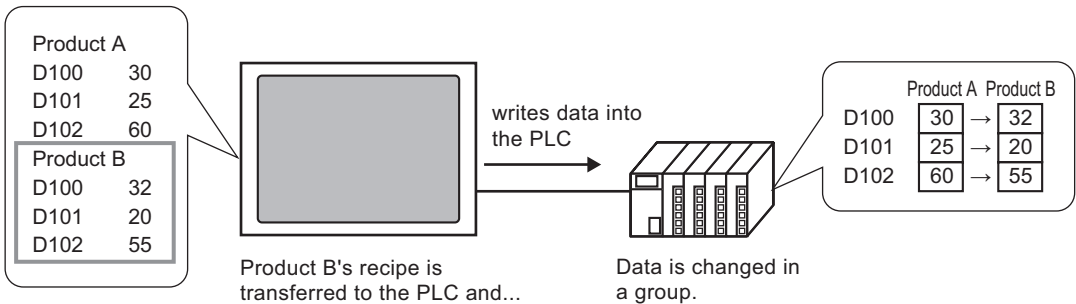

Also, you can read device/PLC data and register it as a new recipe.

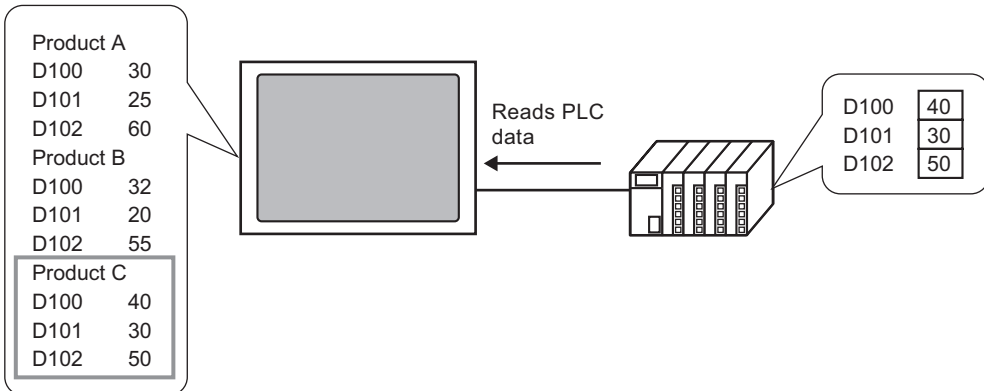

25.1.2 Types of Recipes

There are two types of Recipe.

Transfer CSV Data

Data created as a recipe using a spreadsheet software (Excel) and then converted into a CSV file, and recipe data created in CSV format in GP-Pro EX starting from the beginning is called “CSV data”.

The feature writes CSV data saved on the CF-card to the device/PLC, and saves device/PLC data in CSV format to the CF-card.

-
- | | |
|-------------|--|
| NOTE | <ul style="list-style-type: none"> • The [CSV Data Transfer Function] is suitable for creating standardized data and dividing files into recipes. |
|-------------|--|
-

Transfer Filing Data

Recipe data created in GP-Pro EX (binary data) is called “Filing Data”.

This function writes data from the GP’s backup SRAM to the device/PLC, and stores data from the device/PLC to backup SRAM.

Attributes of CSV data and filing data

Recipe Data	Attribute
CSV Data	<ul style="list-style-type: none"> • Can be transferred directly between the CF-card and PLC. • CF-card data can be displayed, edited, and printed on the GP screen. • Can be created and edited in spreadsheet software (Excel). • A single recipe can be handled as 1 file.
Filing Data	<ul style="list-style-type: none"> • Without using the CF-card, internal data can be saved in the GP unit as a recipe. • Data cannot be displayed or edited on the GP screen. • By transferring data via the GP’s internal device, data can be displayed and edited on the screen. • Multiple recipes, transferred to the same address, can be handled as a single file.

■ CSV Data Flow

Transfer CSV data between the CF-card and the device/PLC.

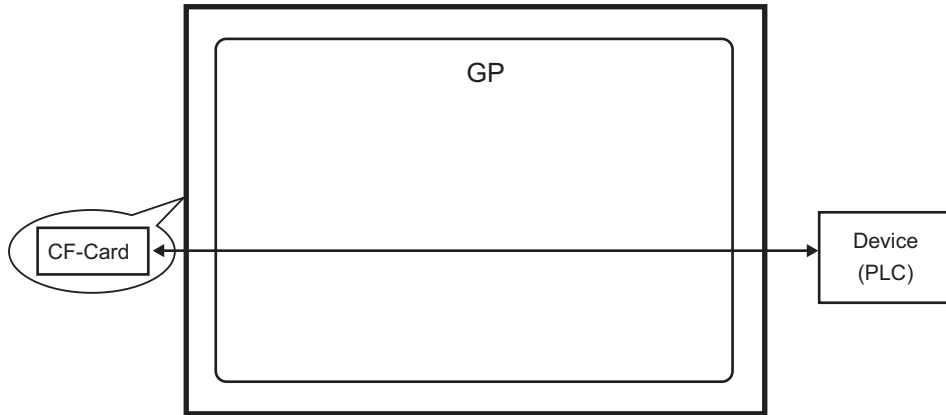

There are two methods for transferring CSV data: control the transfer from the device/PLC (Automatic Transfer), or control the transfer by touching the GP screen (Manual Transfer).

Transfer Methods

	Select the control address and every time the bit is turned ON by the PLC the data is transferred (read/write). The transfer action can be one of the following 2 types.	
Auto- matic transfer	Condi- tion Action	Transfer according to a previously set condition (Destination (Source) Address, No. of Data, etc.). NOTE • By using the Condition Name Search feature, only data that corresponds with the designated condition name will be transferred.
	Address Action	The address is set at the time of transfer. The destination address for the transfer can be changed when the transfer is made.
Manual transfer	Place a Special Data Display [Data Transmission] on the screen, select the file to transfer, and touch the transfer switch. Data is then transferred (read/write).	

■ Filing Data Flow

Filing data created in GP-Pro EX is transferred to the GP's internal memory or the CF-card by screen transfer. In order to transfer data to the PLC, you need to first write data to backup SRAM. This is called "Transfer Preparation".

After transfer preparation, filing data is transferred between backup SRAM and the device/PLC.

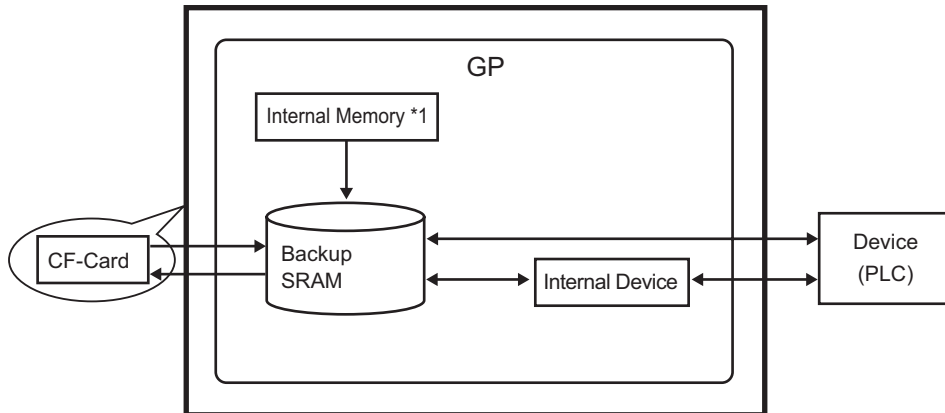

IMPORTANT

- Filing data in backup SRAM and the CF-card can not be edited on the GP screen. It can only be edited in GP-Pro EX. To edit data on the GP screen, transfer it via the GP internal device, and use a Data Display to edit data stored in the internal device.

There are two methods for transferring Filing data: control the transfer from the device/PLC (Automatic Transfer), or control the transfer by touching the GP screen (Manual Transfer).

Transfer Methods

Automatic transfer	Set the control address, and data is transferred when the PLC trigger bit turns ON.
Manual transfer	Place a Special Data Display [Filing] on the screen, select the data (block) to transfer, and touch the transfer switch. Data is then transferred.

*1 Memory where screen data is stored. Filing data created in GP-Pro EX is stored in memory via a screen transfer.

25.2 Settings Menu

Creating Recipes (CSV Data)

Create a Recipe in CSV format in Excel or GP-Pro EX.

ZR00000.csv

350
5
7
12
245
12

ZR00001.csv

400
8
8
16
310
40

- ☞ Setup Procedure (page 25-10)
- ☞ Details (page 25-9)

Transferring Recipes (CSV Data) by Touch

Touch the Special Data Display [Data Transmission]’s transfer switch on the screen and transfer the selected CSV data.

[Data Transmission] Display

Touch the Switch to transfer CF→PLC

Beep

CF-Card

ZR00000.csv

Write CSV data to the PLC

D100	350
D101	5
D102	7

- ☞ Setup Procedure (page 25-18)
- ☞ Details (page 25-17)

Transferring Recipes (CSV Data) from a Device/PLC

Transfer CSV data by turning a designated control address ON.

Control Word Address (D50: 00 Bit)

ON

CF-Card

ZR00000.csv

Write CSV data to the PLC

D100	350
D101	5
D102	7

- ☞ Setup Procedure (page 25-26)
- ☞ Details (page 25-25)

Displaying/Editing CSV Data on the Screen

Display the CF-card's CSV data in a Special Data Display [Show CSV].

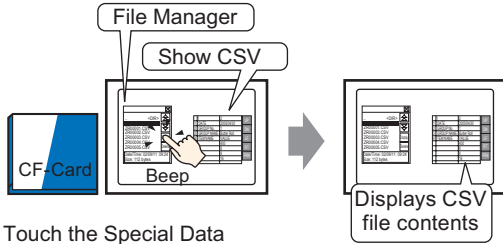

Touch the Special Data Display [File Manager]'s display switch and...

Edit CSV data in the CF-card directly on the screen.

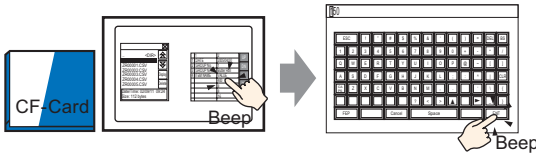

Touch the cell you want to edit on the Special Data Display [Show CSV] and...

The editing screen is displayed

Print CSV data displayed in a [Show CSV].

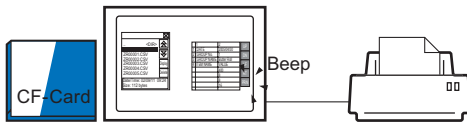

Touch the print switch on the [Show CSV] and...

CSV data is printed.

- ☞ Setup Procedure (page 25-31)
- ☞ Details (page 25-30)

Creating Recipes (Filing Data)

Create Filing data (recipe in binary format) in GP-Pro EX.

Filing Data			
	Block 0	Block 1	Block 2
Item Name	Bread	Butter Roll	Croissant
[PLC1]D00100	350	400	200
[PLC1]D00101	5	8	4
[PLC1]D00102	7	8	3
[PLC1]D00103	12	16	10
[PLC1]D00104	245	310	120
[PLC1]D00105	12	40	10



- ☞ Setup Procedure (page 25-43)
- ☞ Details (page 25-42)

Transferring Recipes (Filing Data) by Touch (Manual Transfer)

Touch the Special Data Display [Filing]'s transfer switch on the screen and transfer the selected Filing data.

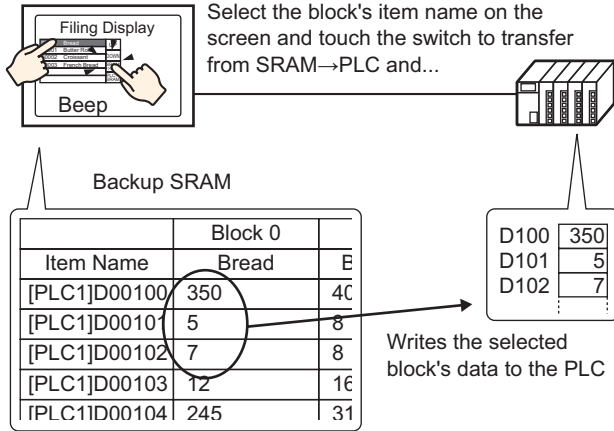

- ☞ Setup Procedure (page 25-47)
- ☞ Details (page 25-46)

Transferring Recipes (Filing Data) from a Device/PLC (Automatic Transfer)

Transfer Filing data by turning a designated control address ON.

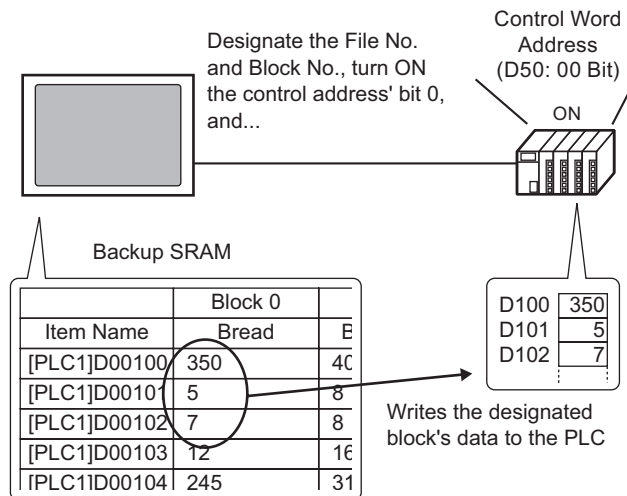

- ☞ Setup Procedure (page 25-53)
- ☞ Details (page 25-52)

25.3 Creating Recipes (CSV Data)

25.3.1 Details

Create a data file (Recipe) in CSV format you want to write to the device/PLC.

There are two methods for creating Recipes: create them using spreadsheet software (Excel) and convert them to CSV format, or create them in GP-Pro EX in CSV format from the beginning.

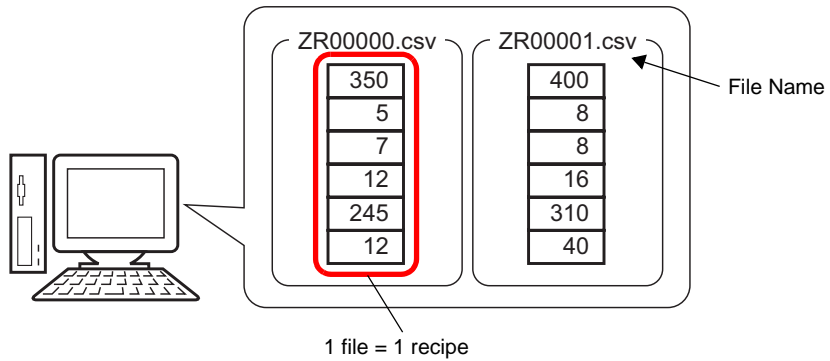

25.3.2 Setup Procedure

■ Create Recipes (CSV data) with Excel

Create recipes using Excel and save them to the CF-card in CSV format.

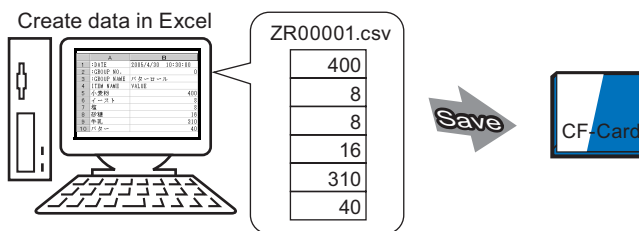

- 1 Open Excel, enter the appropriate values or text under “: DATE”, “: GROUP NO.”, “: GROUP NAME”, “ITEM NAME”, and “VALUE” (see image below), and input recipe data. (The GP unit transfers the data according to these parameters.)

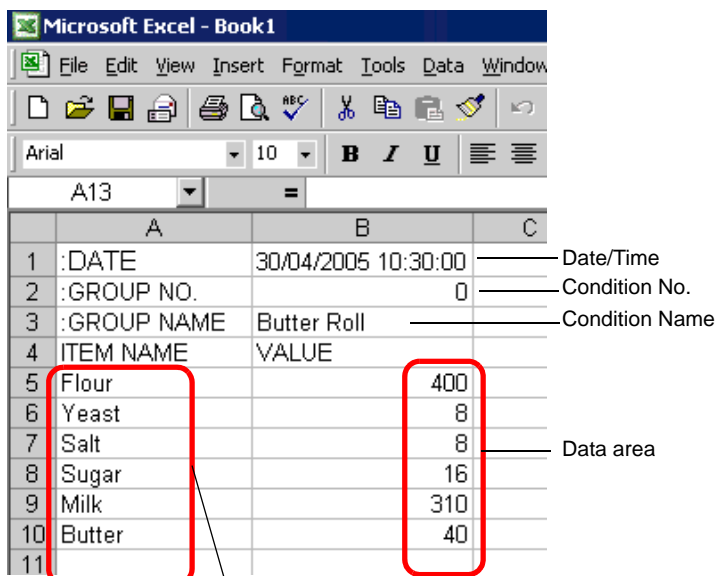

Each data's item name, transfer destination, etc.

: DATE

Enter the data's creation date.

: GROUP NO.

Enter the Condition No. to be transferred.

: GROUP NAME

Enter an optional Condition Name.

ITEM NAME

The area below the ITEM NAME field can be used for entering any desired information.

You may enter comments as necessary.

VALUE

Input data in the area below the VALUE field. The data format is Dec.

- NOTE** • Only the data portion will be transferred to the device/PLC via Transfer CSV Data. Enter the Creation Date, Condition No., Condition Name, and comment as needed. At transfer time, regardless of the condition no. and condition name, data will be transferred according to the set condition in [Recipe Settings] - [Transfer CSV Data (Condition Settings)].

2 Save to the CF-card.

Designate the the CF-card’s [FILE] folder as the file save destination.

Select “CSV” for the file type, and set the file name to “ZR*****.csv” (***** is a 5-digit file number designated from 00000 to 65535).

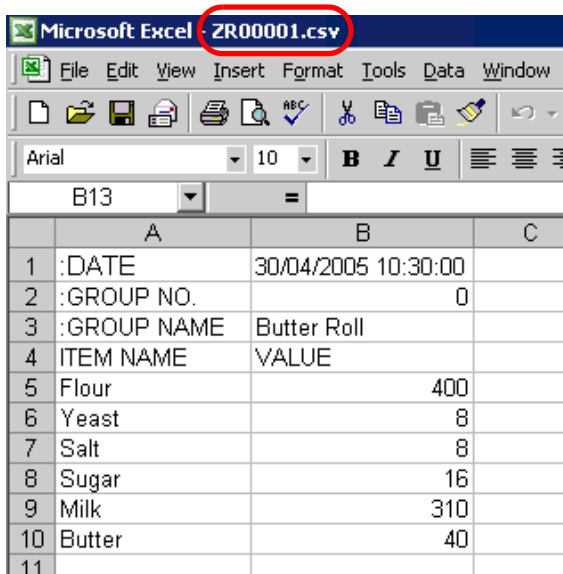

The Recipe “ZR00001.csv” has been created.

If your computer does not have CF-card drivers, set the CF-card export folder and save. The CF-card output folder data is transferred to the GP’s CF-card via a screen transfer.

- NOTE** • Select the CF-card export folder with the GP-Pro EX [Project (F)] menu - [Properties (I)] option - [CF-Card Output Folder (C)] command.

◆ **Editing data transferred from PLC→CF-card in Excel**

Data transferred from PLC→CF-card can also be edited in Excel and saved as a new file. When opening the transferred CSV data in Excel, it will appear as follows.

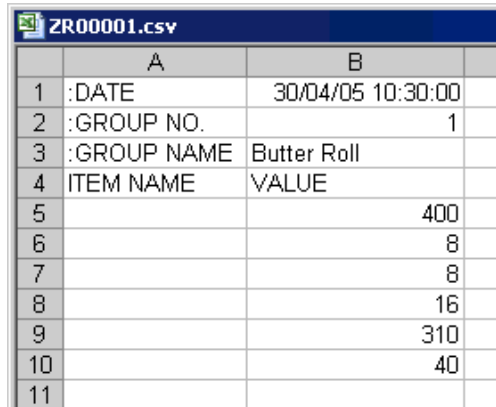

	A	B
1	:DATE	30/04/05 10:30:00
2	:GROUP NO.	1
3	:GROUP NAME	Butter Roll
4	ITEM NAME	VALUE
5		400
6		8
7		8
8		16
9		310
10		40
11		

: DATE

The date when data was saved to the CF-card is written. Date is displayed with 2 digits as in “30/04/05”.

: GROUP NO.

The Condition No.. set in the conditional settings is written.

: GROUP NAME

The Condition Name set in the conditional settings is written.

ITEM NAME

The area under this item is blank.

VALUE

The area under this item contains the transferred data.

■ Create Recipes (CSV data) with GP-Pro EX

- NOTE** • Please refer to the settings guide for details.
 ☞ “25.10.1 Recipe Settings Guide ■ Transfer CSV Data (CSV File List)” (page 25-61)

Create a Recipe in GP-Pro EX as CSV format data. Created data is saved to the GP’s CF-card using screen transfer.

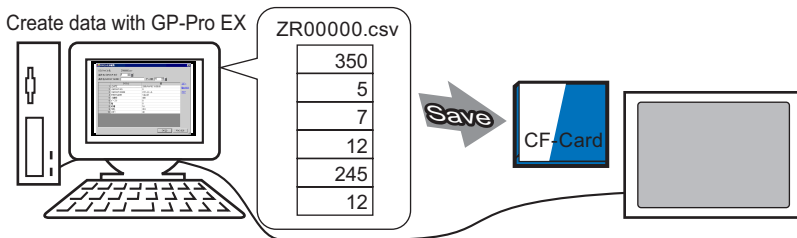

- 1 Select the [Common Settings (R)] menu - [Recipe Settings (R)] option - [Transfer CSV Data (CSV File List) (F)] command and the following screen opens.

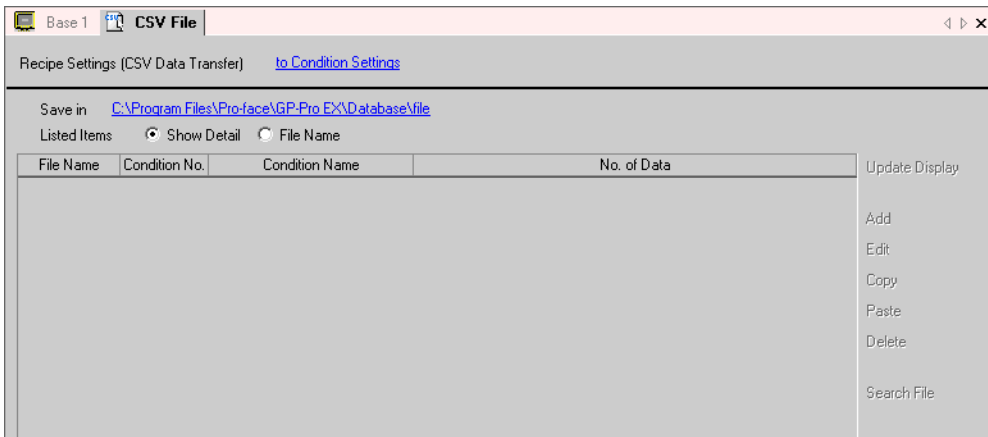

If the CF-Card Export Folder is not yet set, the following message will appear. Click [Yes].

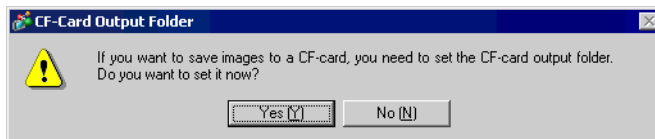

When the following dialog box appears, put a check mark next to the [Enable CF-Card] box, click [Reference] and designate the CF-Card Export Folder. Click [OK] and the dialog box closes.

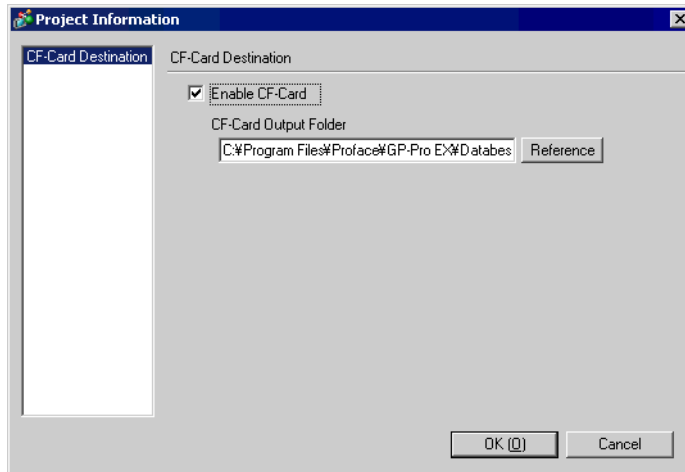

- NOTE**
- The CF-Card Export Folder is the location where created data is temporarily saved inside the project. The data saved here will be saved to the CF-card via a screen transfer.
 - Even if the CF-card export folder is selected with the [Project (F)] menu - [Properties (I)] option - [CF-Card Output Folder (C)] command, it can be set in the same way.

2 Click [Add] and the [Add CSV File] dialog box is displayed.

Designate the [CSV File No.] and click [OK].

In the file name "ZR*****.csv", ***** represents the file number portion designated here.

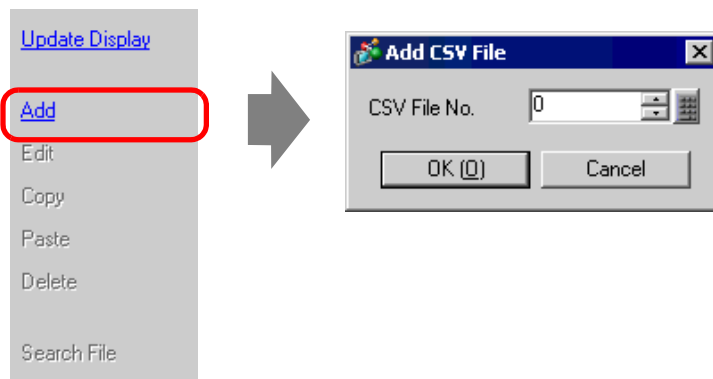

- NOTE**
- To click [Add], [Transfer CSV Data] should be checked on the [Recipe Settings (R)]'s [Transfer CSV Data (Condition Settings) (T)] tab.

☞ "25.4.2 Setup Procedure" (page 25-18)

3 The [Edit CSV File] dialog box appears.

Designate the transfer condition in [Condition No. (GROUP NO)] and input the recipe's name in [Condition Name (GROUP NAME)]. Set the [No. of Data], and input each data's value and title, then click [OK].

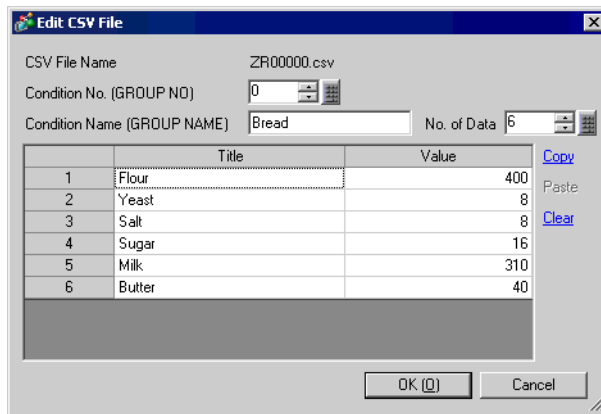

4 The created recipe (ZR00000.csv) appears in the file list.

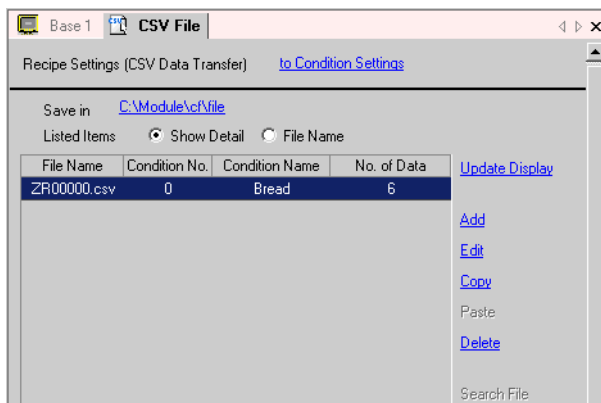

To edit data, select the file to edit and click [Edit].

The created recipe (ZR00000.csv) is saved in the [FILE] folder in the designated CF-card output folder with the following format.

	1st Column	2nd Column	
1st Row	:DATE	(Date Saved)	
2nd Row	:GROUP NO.	(Condition No.)	
3rd Row	:GROUP NAME	(Condition Name)	
4th Row	ITEM NAME	VALUE	
5th Row	Flour	350	} Created data
6th Row	Yeast	5	
7th Row	Salt	7	
8th Row	Sugar	12	
9th Row	Milk	245	
10th Row	Butter	12	

- “:DATE”, “:GROUP NO”, “:GROUP NAME”, “ITEM NAME”, and “VALUE” are fixed.
- The date saved will be automatically written in the format “yyyy/mm/dd hh:mm:ss”.
- The condition no. and condition name, which are set in the conditional settings, are written.
- Under “ITEM NAME” in the first column, the designated titles are written.
- Under “VALUE” in the second column, the designated values are written.

25.4 Transferring Recipes (CSV Data) by Touch

25.4.1 Details

Recipe files (CSV data files) to be transferred on the CF-card are displayed on the screen in a list. Touch to select/deselect the desired files, and they are written to the PLC.

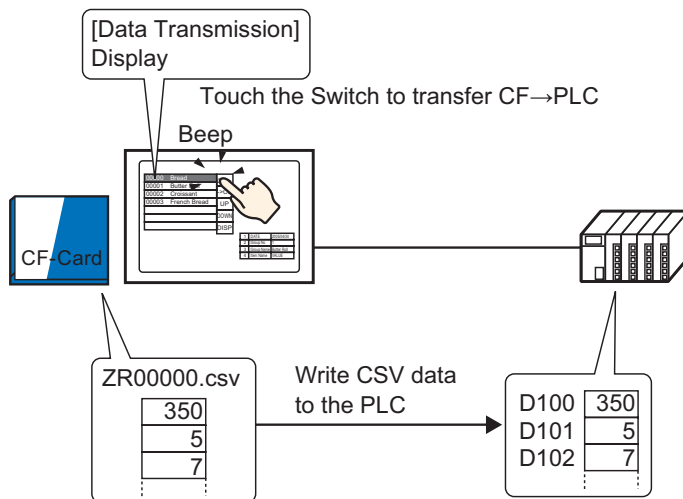

Also, device/PLC data is saved and overwrites the selected files inside the CF-card.

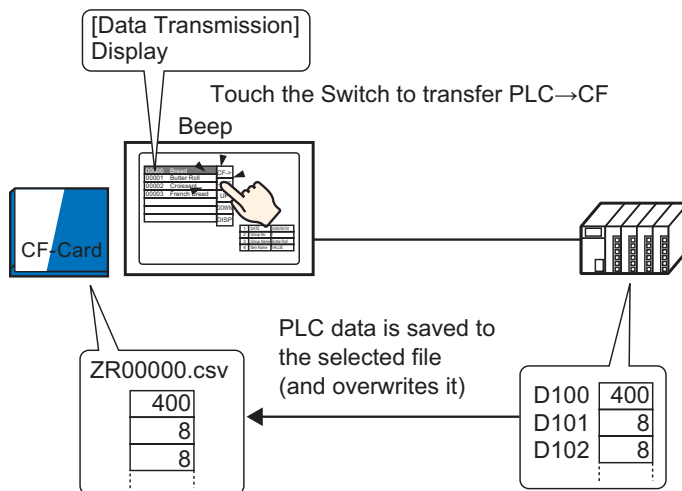

- NOTE**
- For manual transfer between PLC→CF-card, data can not be saved as a new file. Data can only overwrite a file selected in a Special Data Display [Data Transmission].

25.4.2 Setup Procedure

NOTE

- Please refer to the settings guide for details.
 - ☞ “25.10.1 Recipe Settings Guide ■ Transfer CSV Data (Condition Settings)” (page 25-56)
 - ☞ “25.10.2 Special Data Display Settings Guide ■ Data Transmission” (page 25-72)
- For details about placing parts or setting addresses, shapes, colors, and labels, please refer to the “Part Editing Procedure”.
 - ☞ “9.6.1 Procedure for Editing a Part” (page 9-36)

On the GP screen’s Special Data Display [Data Transmission], the following settings show how to designate and transfer the CSV data by touching it.

- 1 Select the [Common Settings (R)] menu - [Recipe Settings (R)] option - [Transfer CSV Data (Condition Settings) (T)] command, or click . The following screen appears.

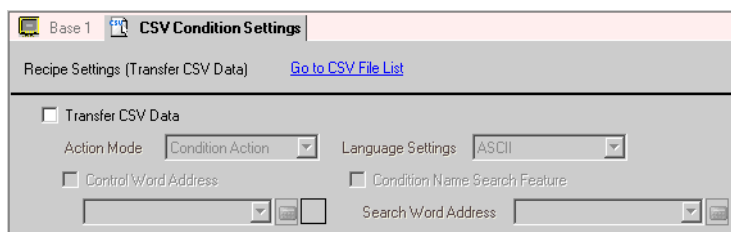

- 2 Put a check mark next to the [Transfer CSV Data] box, and set [Action Mode] to [Condition Action].

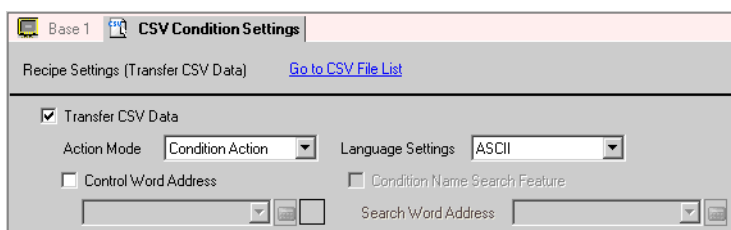

3 Click [Create] on the Condition Settings. The [CSV Data Transfer Condition Settings] dialog box opens.

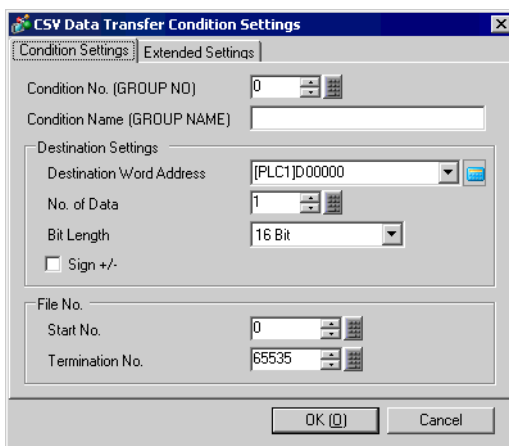

4 Input the [Condition No.] and [Condition Name] to register.

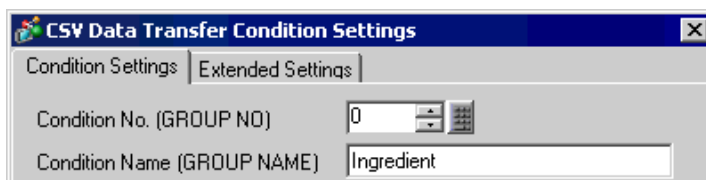

5 Designate the destination device/PLC's top address (D100) in [Destination Word Address] and set the No. of Data and bit length.

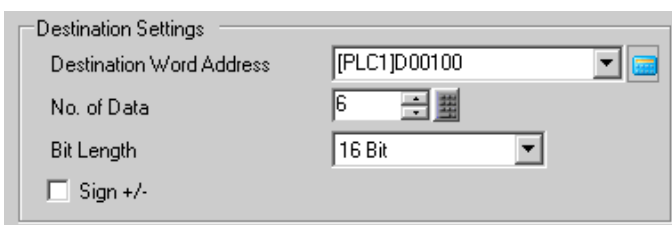

6 Designate the [Start No.] and [Termination No.] of the recipe file (ZR*****.csv) to transfer with this condition.

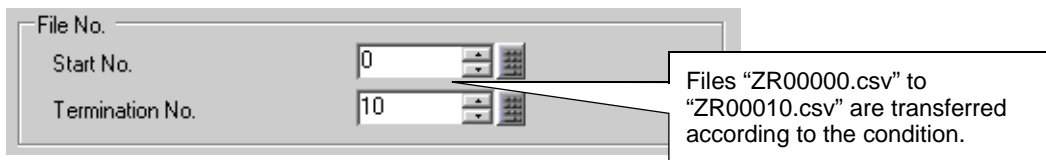

- 7 Click [OK], the condition is registered and the dialog box closes.
The registered condition appears.

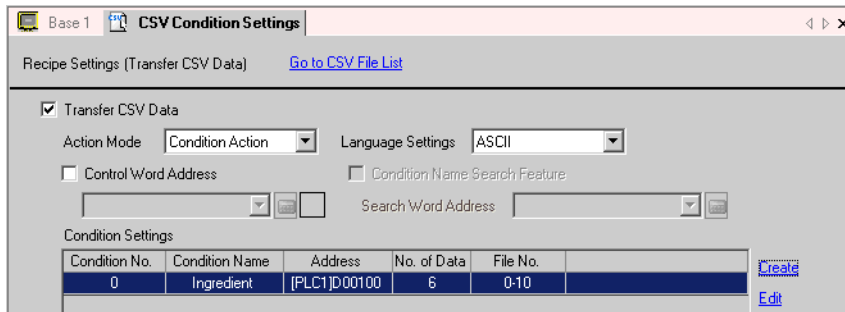

In the same manner, register as many conditions as are needed.

- 8 Select the screen editor. Select the [Part (P)] menu - [Special Data Display (P)] option - [Data Transmission (D)] command, or click , and place the Part on the screen.

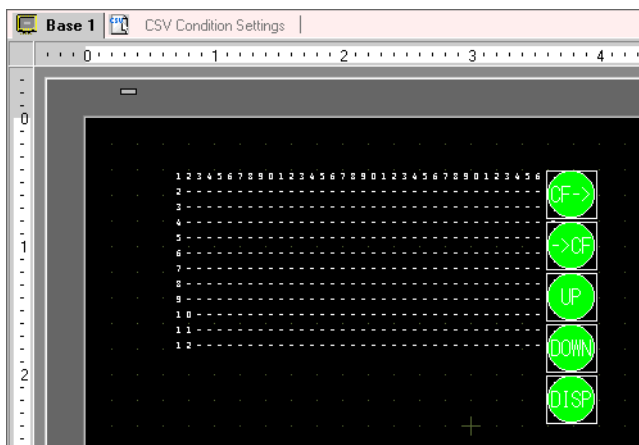

9 Double-click the placed Special Data Display and the settings dialog box opens.

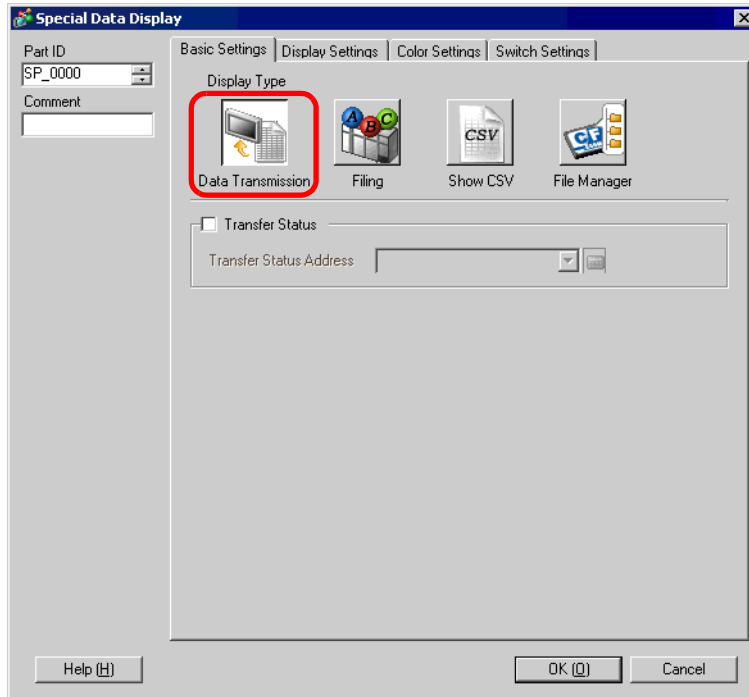

10 Select the [Display Settings] tab, and set the font settings and display format.

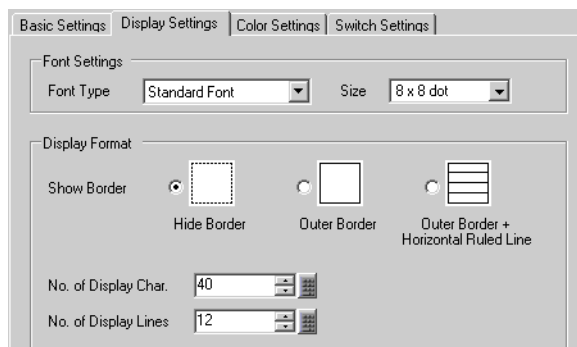

11 Select the [Color Settings] tab, and set the text and background color.

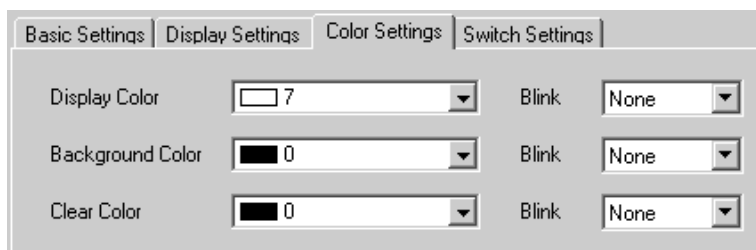

- 12 Select the [Switch Settings] tab, and select the operation switches you want to place. Set the number of rows that a scroll switch will scroll when pressed once. Select the switches' shapes, set the label and text color, and click [OK].

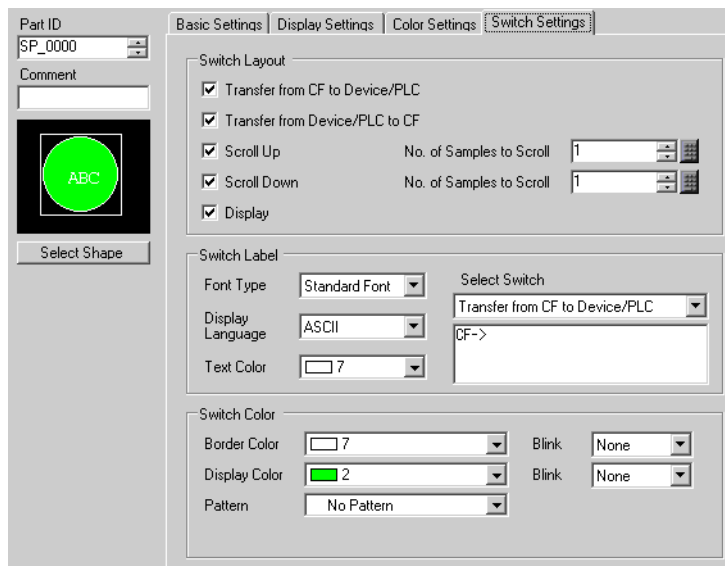

Special Data Display Part [Data Transmission] is now set. You can move the attached [Data Transmission] switches independently to the desired location.

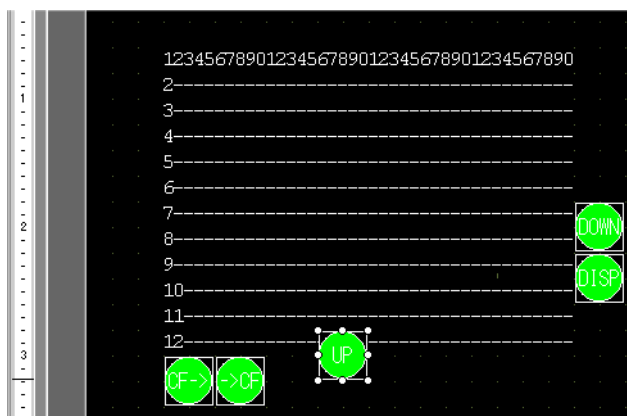

-
- NOTE** • If you want to display CSV data on the GP screen, place a Special Data Display [Show CSV].
- ☞ “25.6 Displaying/Editing CSV Data on the Screen” (page 25-30)
-

25.4.3 Transfer Process

The file number (the ***** portion of the file name “ZR*****.csv”) and condition name of recipes stored in the CF-card are displayed on the Special Data Display [Data Transmission] on the GP screen.

- 1 Select the file to transfer by touching it. (Selected rows are displayed in reverse color.) You can select multiple files from the displayed list.

NOTE • If you touch a scroll switch while a file is selected, the displayed page will change and the selection will be cancelled.

- 2 Touch the CF-Card→Device/PLC or Device/PLC→CF-Card transfer switch. Each file number will be transferred according to a previously set condition.

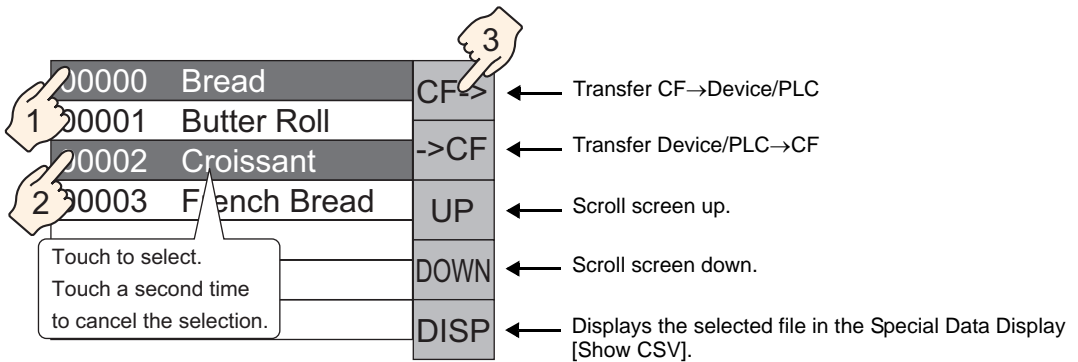

IMPORTANT

- When transferring from device/PLC to CF-card, data inside the CF-card is overwritten. At that time, the file's condition name is rewritten by the condition settings' condition name.
- If you have selected multiple files, the transfer will occur in order starting with the smallest file number.
- In the Special Data Display [Data Transmission], CSV files appear in the order they were created. You can not sort by File No. or timestamp.

If both a Special Data Display [Data Transmission] and [Show CSV] are placed on the same screen, when you select a file and press the display switch, Recipes (CSV data) will appear in the [Show CSV].

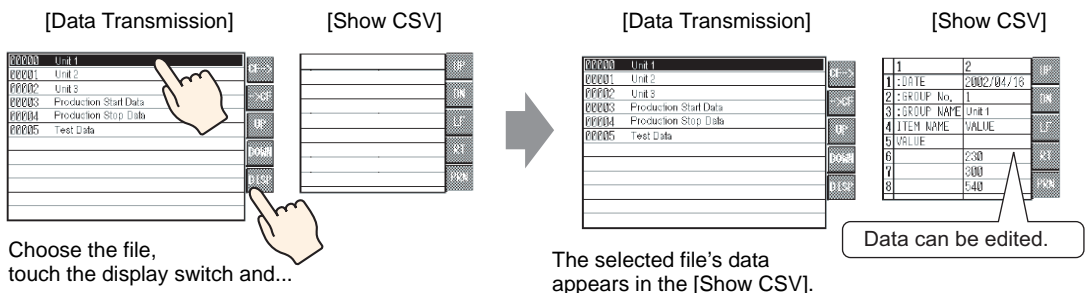

NOTE

- If you select multiple files and touch the display switch, the file with the smallest file number will be displayed.
 - If you set up the Special Data Display [Show CSV] to be able to edit data, you can edit displayed data by touching it. You can use this when you want to edit CSV data in the CF-card on the screen and write it to the device/PLC.
 - You can use a Special Data Display [File Manager] and display/edit it in a [Show CSV].
 - ☞ “25.6 Displaying/Editing CSV Data on the Screen” (page 25-30)
-

25.5 Transferring Recipes (CSV Data) from a Device/PLC

25.5.1 Details

When the designated Control Address' bit 0 turns ON, the specified CSV data in the CF-card is written to the device/PLC according to the a previously set transfer condition (Destination Address, No. of Data, etc.).

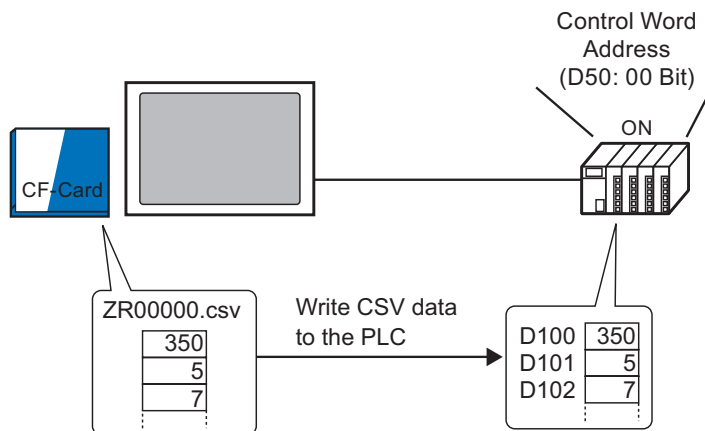

Also, when the Control Address' bit 1 turns ON, the device/PLC's data is read and saved to the CF-card as new CSV data according to the previously set transfer condition (Destination Address, No. of Data, etc.).

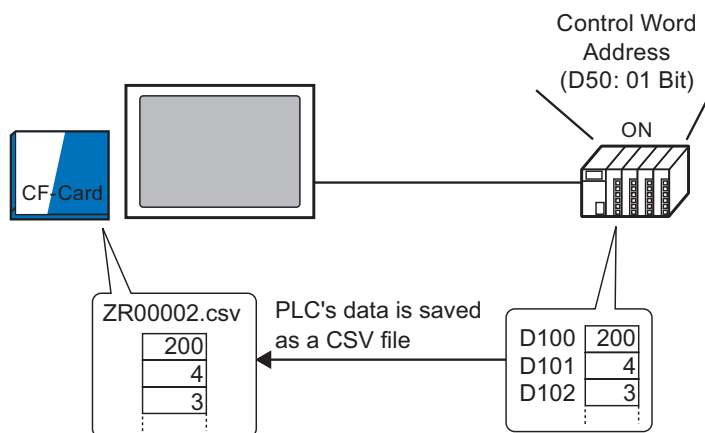

NOTE

- You can transfer multiple files (up to a maximum of 64) at one time.
- You can designate the destination (or source) address, No. of Data, etc., for each file at the transfer time.

☞ "25.11.2 Control Word Address ◆ For Address Action" (page 25-93)

25.5.2 Setting Procedure

NOTE

- Please refer to the settings guide for details.
 ☞ “25.10.1 Recipe Settings Guide ■ Transfer CSV Data (Condition Settings)” (page 25-56)

Configure settings so that when the designated address’ (D50) bit 0 turns ON, the specified CSV data is transferred according to the previously set condition.

- 1 Select the [Common Settings (R)] menu - [Recipe Settings (R)] option - [Transfer CSV Data (Condition Settings) (T)] command, or click . The following screen will appear.

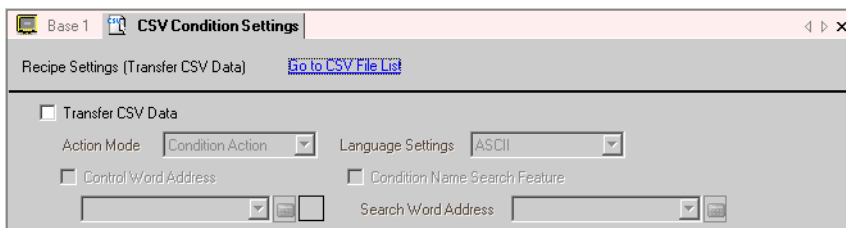

- 2 Put a check mark next to the [Transfer CSV Data] box, and set [Action Mode] to [Condition Action].

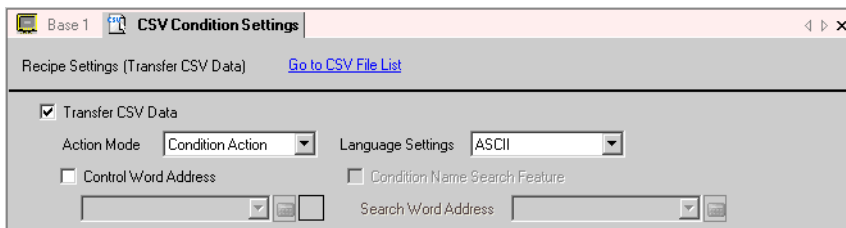

- 3 Put a check next to the [Control Word Address] box and set the address (D50) used to operate the transfer from the device/PLC.

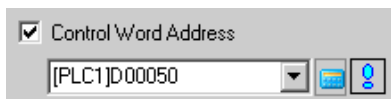

4 Click [Create] on the Condition Settings. The [CSV Data Transfer Condition Settings] dialog box opens.

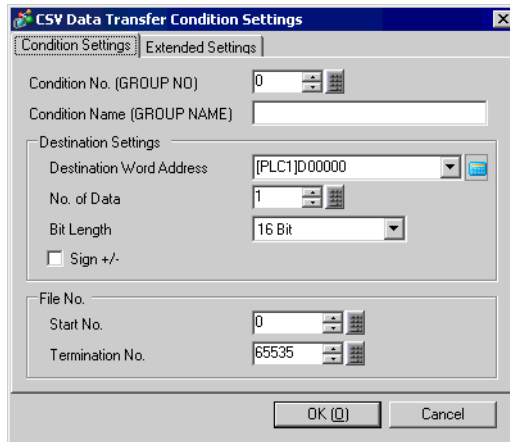

5 Input the [Condition No.] and [Condition Name] to register.

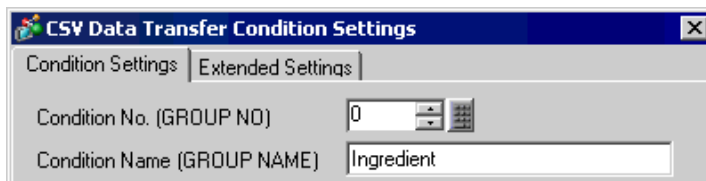

6 Designate the destination device/PLC's top address (D100) in [Destination Word Address] and set the No. of Data and bit length.

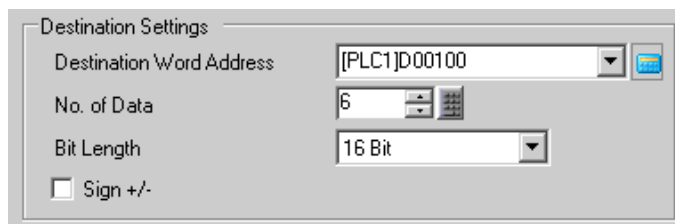

7 Designate the [Start No.] and [Termination No.] of the recipe file (ZR*****.csv) to transfer with this condition.

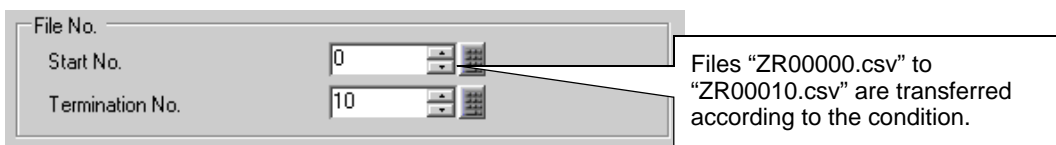

8 Click [OK], the condition is registered and the [CSV Data Transfer Condition Settings] dialog box closes.

The registered condition appears.

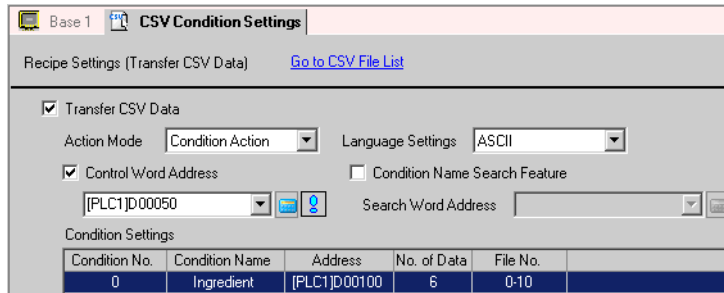

In the same manner, register as many conditions as are needed.

NOTE

- If you set the [Condition Name Search Feature] and designate a condition name to search for, the CSV file with that condition name will automatically be found and transferred.
 - ☞ “25.11.3 Condition Name Search Feature” (page 25-98)
- When using automatic transfer from device/PLC to CF-card, you can automatically allot the file numbers and create new files in the CF-card.
 - ☞ “25.11.4 Automatic Numbering” (page 25-104)

25.5.3 Transfer Process

Transfer CF→Device/PLC

Transfer a single recipe file “ZR00000.csv” to a device/PLC.

D50	Control	
D51	Status	
D52	No. of Files	← “1”
D53	File No. 1	← “0”

- 1 In D52, store the number of CSV files to transfer “1”.
- 2 In D53, store the File No. “0”.
- 3 Turn ON D50’s bit 0. According to the settings of Condition No. 0, data is transferring into 6 words, D100 to D105.
During the data transfer, D51 (Status address)’s bit 0 (Transferring Bit) turns ON.
- 4 When all files have completed transfer normally, D51’s bit 0 turns OFF, and bit 1 (Transfer Completion Bit) turns ON.
Turn OFF D50’s bit 0.

Transfer CF→Device/PLC

Save 6 words of data, D100 to D105, to the CF-card as “ZR00002.csv”.

D50	Control	
D51	Status	
D52	No. of Files	← “1”
D53	File No. 1	← “2”

- 1 In D52, store the number of CSV files to transfer “1”.
- 2 In D53, store the File No. “2”.
- 3 Turn ON D50’s bit 1. According to the settings of Condition No. 0, data from 6 words, D100 to D105, are transferred as “ZR00002.csv”.
During the data transfer, D51 (Status address)’s bit 0 (Transferring Bit) turns ON.
- 4 When all files have completed transfer normally, D51’s bit 0 turns OFF, and bit 1 (Transfer Completion Bit) turns ON.
Turn OFF D50’s bit 1.

25.6 Displaying/Editing CSV Data on the Screen

25.6.1 Details

By using a Special Data Display [File Manager] and [Show CSV], CSV-format files saved on the CF-card (Recipe data, Alarm History data, Sampling data, etc.) can be displayed on the GP screen. This is used to verify data on the GP unit.

Displays the CF-card's CSV data on the GP screen.

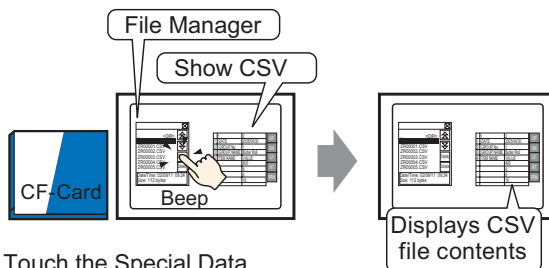

Touch the Special Data Display [File Manager]'s display switch and...

Data displayed on the screen can be edited by touching it. Also, data can be printed using a printer connected to the GP unit.

Edit CSV data on the screen.

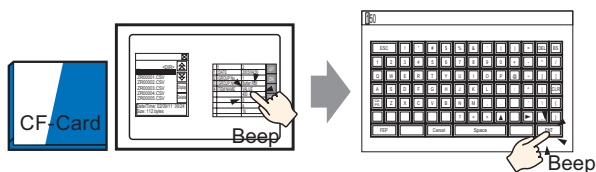

Touch the cell you want to edit on the Special Data Display [Show CSV] and...

The editing screen is displayed

Print CSV data from a printer connected to the GP unit.

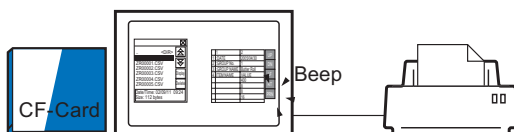

Touch the print switch on the [Show CSV] and...

CSV data is printed.

25.6.2 Setup Procedure

NOTE

- Please refer to the settings guide for details.
 - ☞ “25.10.2 Special Data Display Settings Guide ■ File Manager” (page 25-86)
 - ☞ “25.10.2 Special Data Display Settings Guide ■ Show CSV” (page 25-81)
- For details about placing parts or setting addresses, shapes, colors, and labels, please refer to the “Part Editing Procedure”.
 - ☞ “9.6.1 Procedure for Editing a Part” (page 9-36)

Configure settings to display/edit/print CSV format data.

- 1 Select the [Part (P)] menu - [Special Data Display (P)] option - [File Manager (M)] command and place the Part on the screen.

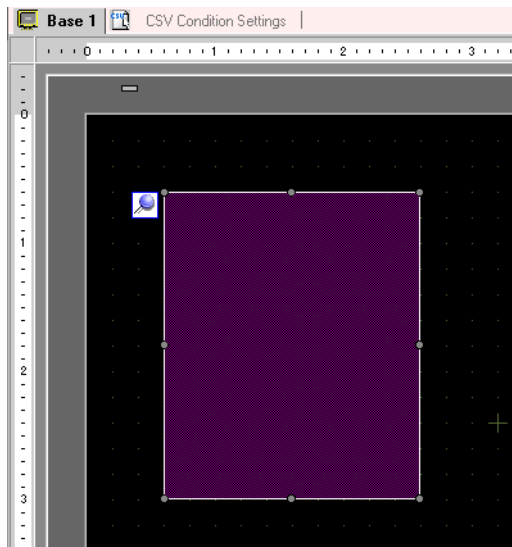

2 Double-click the placed Special Data Display [File Manager] and the settings dialog box opens.

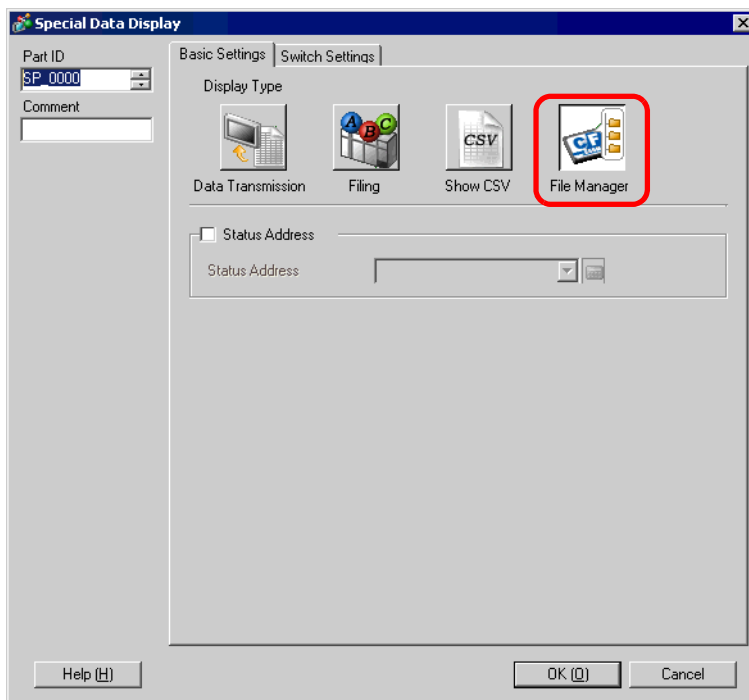

3 Select the [Switch Settings] tab and put a check mark next to the [Display] box under [Switch Layout]. Select the File Manager Display Switch's shape, set the label and text color, and click [OK].

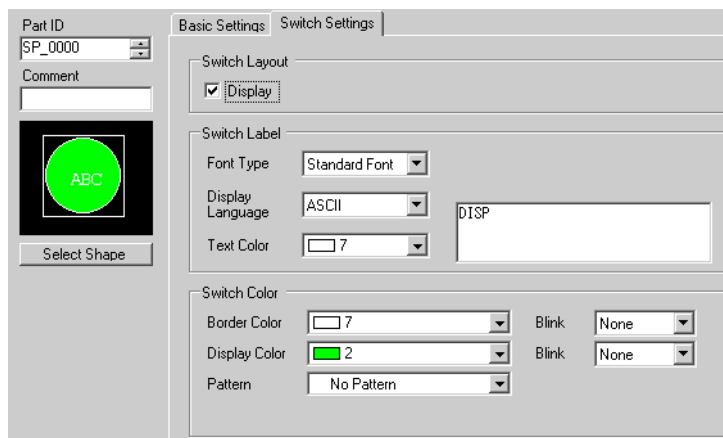

4 Special Data Display Part [File Manager] is now set. You can move the attached [File Manager] switch independently to the desired location.

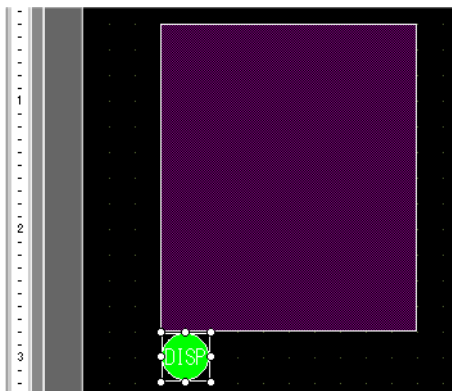

5 On the same screen as the placed [File Manager], select the [Part (P)] menu - [Special Data Display (P)] option - [CSV Display (C)] command and place the [CSV Display] on the screen.

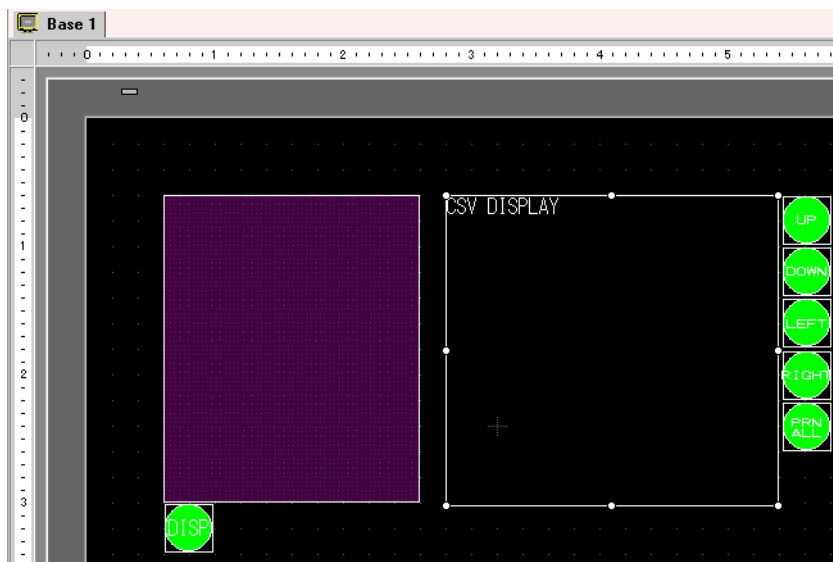

6 Double-click the placed Special Data Display [Show CSV] and the settings dialog box opens.

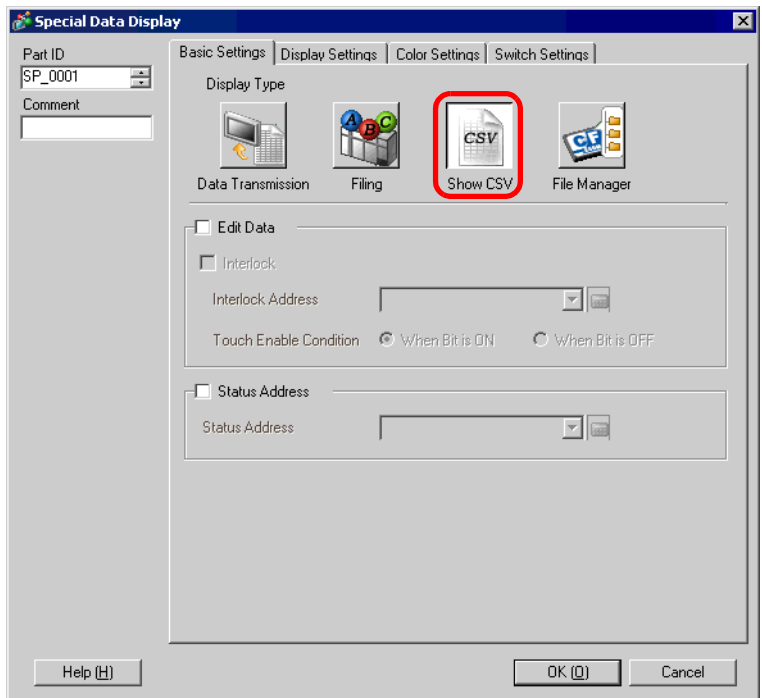

7 Put a check mark next to [Edit Data].

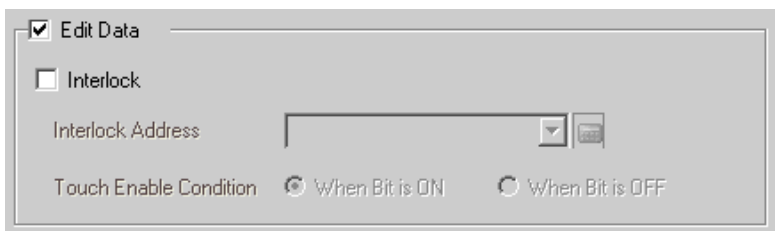

8 Select the [Display Settings] tab, and set the data's font type and size. Put a check mark next to the [Show Column] box if needed.

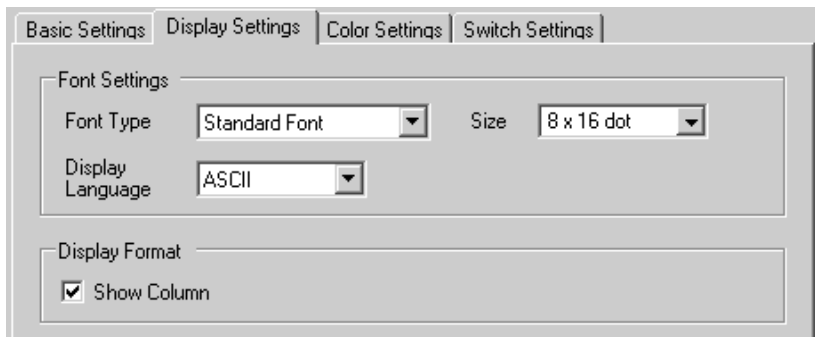

9 Select the [Color Settings] tab, and set the data's text color and background color.

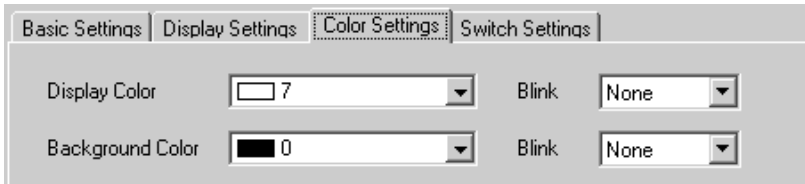

10 Select the [Switch Settings] tab, and put a check mark next to any necessary scroll or print switches for the Show CSV. Set the number of rows or columns that a scroll switch will scroll when pressed once.

Select the switches' shapes, set the label and text color, and click [OK].

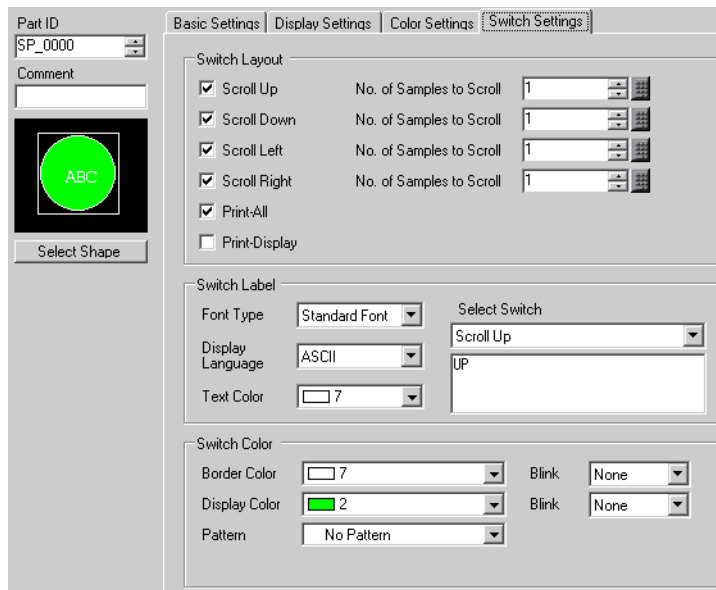

Special Data Display Part [Show CSV] is now set. You can move the attached [Show CSV] switches independently to the desired location.

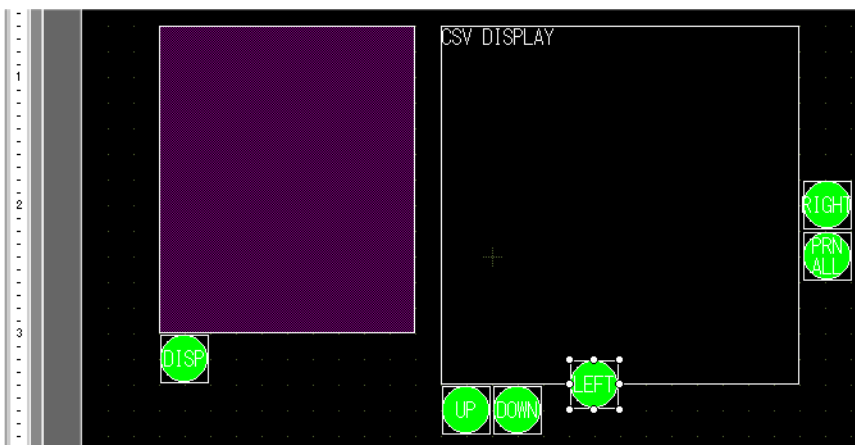

25.6.3 Operation Process

■ Displaying CSV Data

To display data in a Special Data Display [Show CSV], you need a Special Data Display [File Manager] in order to select files to display.

IMPORTANT

- A Special Data Display [File Manager] is displayed using a Special Window or Local Window. If the maximum number of windows are already displayed, the File Manager cannot display. Close another window and touch the [File Manager] display switch to make it appear.
 ☞ “18.8 Restrictions for Windows” (page 18-28)

1 Touch the File Manager Display Switch and the [File Manager] is called to the GP screen.

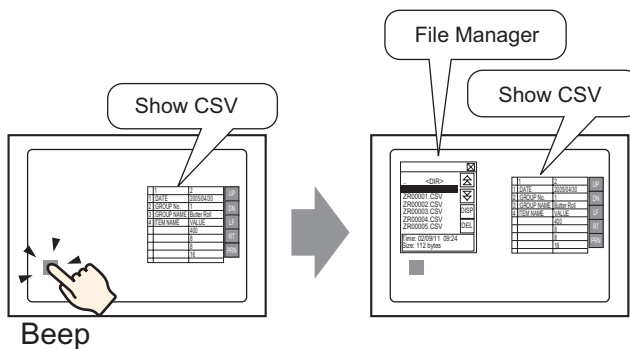

When the switch is pressed again, the [File Manager] closes.

The contents of the CF-card's root folder appear in the [File Manager].

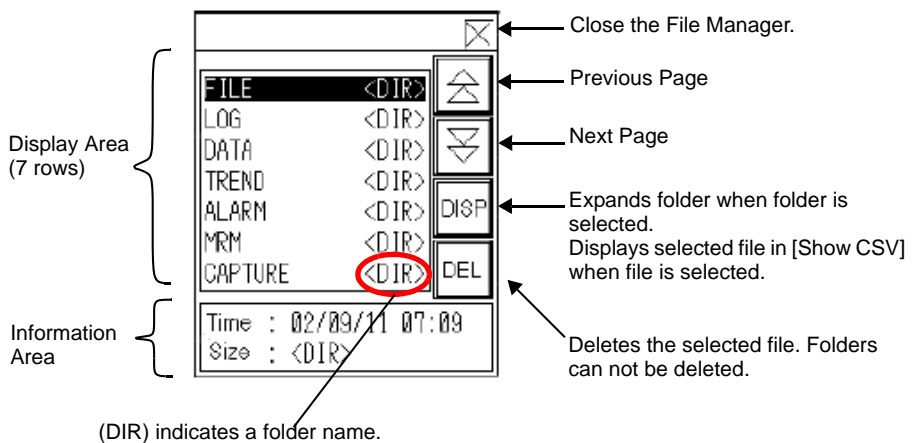

- **Display Area**
 Displays the folder names and file names on the CF-card in a list. Files appear in the order they were created. You can not sort by File No. or timestamp.
- **Information Area**
 Displays the creation date and file size of the selected file. The file size is not displayed when a folder is selected.

2 If the [DISP] key is touched while a folder is selected, the contents of the folder will be displayed.

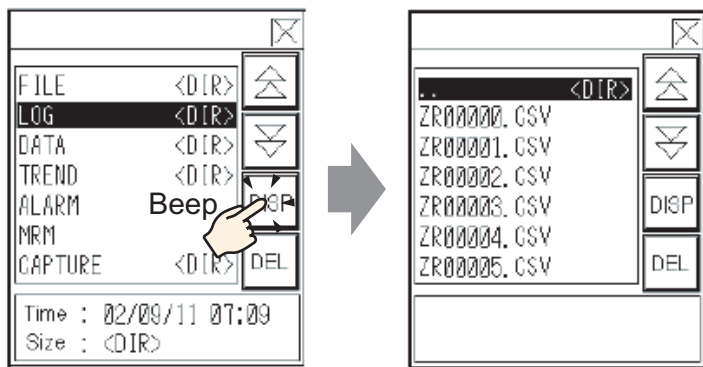

NOTE • Select the “.. <DIR>” column and touch the [DISP] key to display a folder in a higher directory.

3 When a CSV file is selected and the [DISP] key is touched, the file’s data will appear in the [Show CSV].

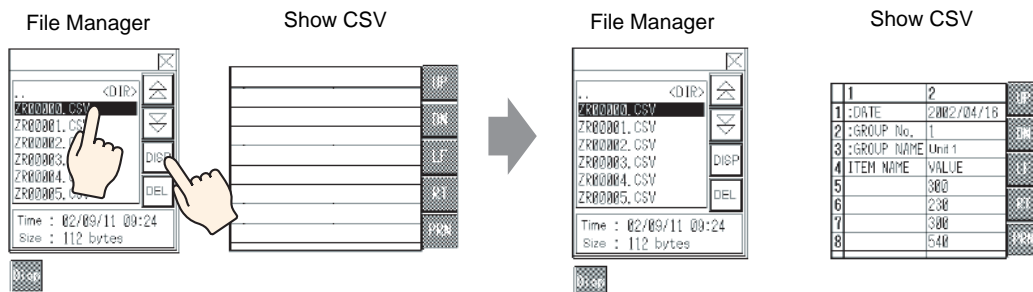

NOTE • In the Special Data Display [File Manager], if a file other than a CSV file is selected and the [DISP] key is pressed, it will not appear in the [Show CSV].
 • If the CF-card is removed or the cover of the CF-card slot is opened while the data of the CSV file is displayed on the [Show CSV], the display will be automatically cleared.
 • Switching screens clears the [Show CSV]’s display.

You can display all CSV data (Alarm History data, sampling data, etc.) created with the GP in the Special Data Display [Show CSV]. Change the [Show CSV]'s display with the specialty scroll switches (up, down, left, right).

Special Data Display Part [Show CSV]

1	2	UP	← Scroll Up
1:DATE	2002/04/18	DN	← Scroll Down
2:GROUP No.	1	LF	← Scroll Left
3:GROUP NAME	Unit 1	RT	← Scroll Right
4:ITEM NAME	VALUE	PRN	← Print CSV Data
5:VALUE			
6	230		
7	300		
8	540		

NOTE

- Up to 100 characters can be entered in each cell.
- Each cell's data will be displayed as text. The display of the text in each cell is fixed as left-aligned.
- The outer borders are 2-dot lines, and the inner borders are 1-dot lines. Two-dot spaces are left between the borders separating the cells and the data in the cells.

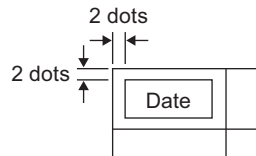

- The height of the cell will be automatically adjusted depending on the font size. As well, the width of each cell will be automatically adjusted depending on the data (text) width to display. However, when the number of characters is five or less, the width is set to five characters.

Moving a File Manager

The Special Data Display [File Manager]'s display position on the screen can be changed.

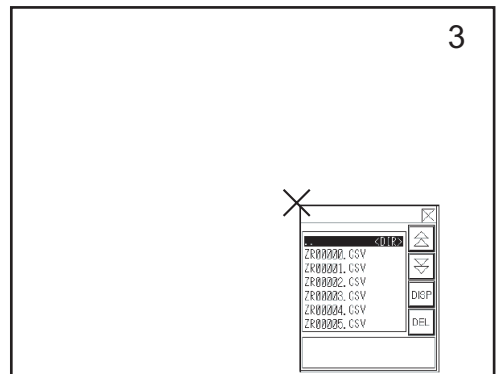
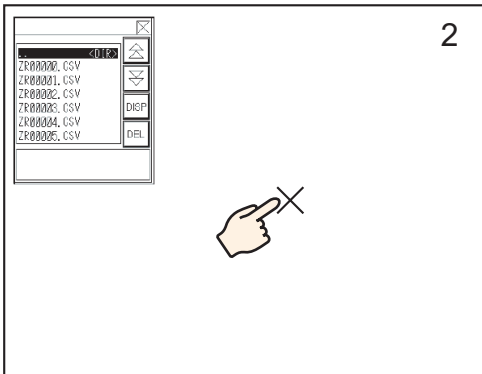
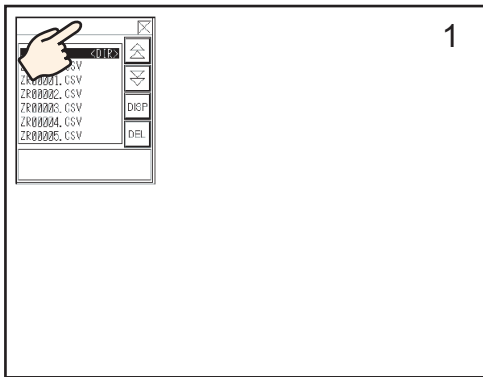

- 1 Touch the top area of the [File Manager] Display.
- 2 Touch the desired location on the screen where you want to move it.
- 3 The [File Manager] Display moves to the specified position.

NOTE

- If the [File Manager] Display is out of the screen in the designated position, the coordinates will be automatically adjusted so that the window can be displayed.

■ Editing CSV Data

If the Special Data Display [Show CSV]’s [Edit Data] feature is set, touching a displayed cell automatically displays the editing screen. Touch the keypad on the editing screen to directly edit the CF-card’s data.

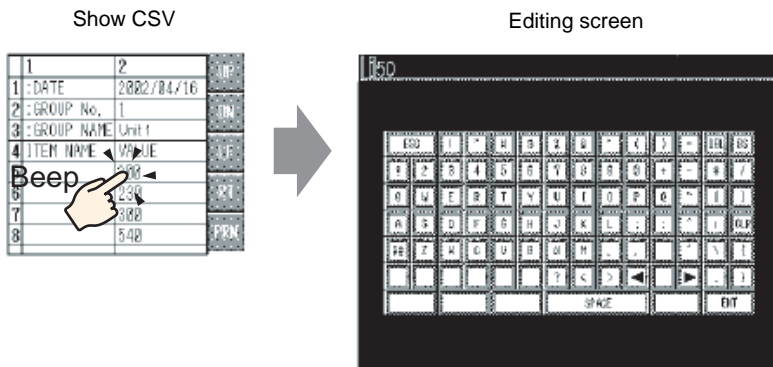

Touching the [ENT] key after editing data with the editing screen’s keypad confirms the changes and closes the editing screen.

NOTE

- Touching the [CAPS] key allows you to input lower-case characters. Touching the [CAPS] key again returns to upper-case input mode. The [CAPS] key is cleared when the editing screen is closed.
- The input text on the editing screen is displayed with the font set to the CSV display. The display color, display position, and size is system-fixed and cannot be changed by users.

■ Printing CSV Data

Touch the print switch on the Special Data Display [Show CSV], and you can print the displayed CSV data from a printer connected to the GP.

You can also print only the portion displayed in the [Show CSV].

NOTE • To print data, you must connect a printer to the GP and configure the printer settings.

☞ “28.3.2 Printer Setup Procedure” (page 28-11)

Print All

Touch [PRN ALL], and all CSV data on the [Show CSV], including the region not displayed on the screen, is printed.

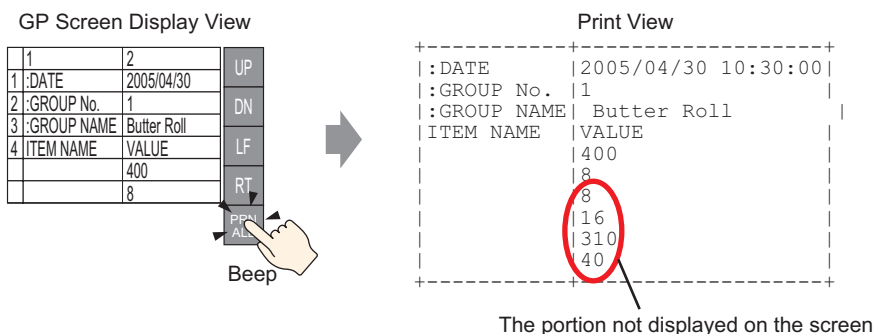

Print-Display

Touch [PRN], and only CSV data displayed on the screen is printed.

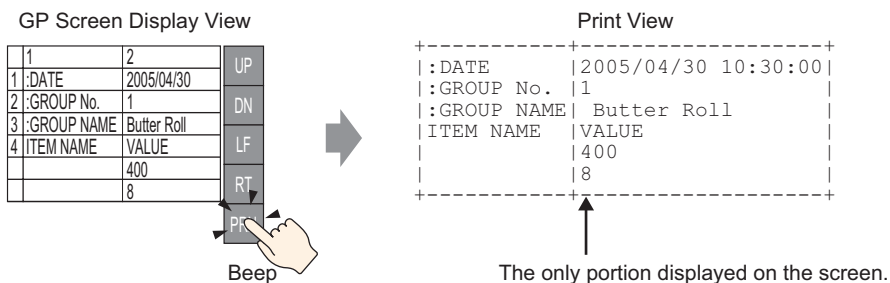

25.7 Creating Recipes (Filing Data)

25.7.1 Details

Create filing data (recipes in binary format) in GP-Pro EX.

Created data is sent to internal memory or saved to the CF-card inserted in the GP unit via a screen transfer.

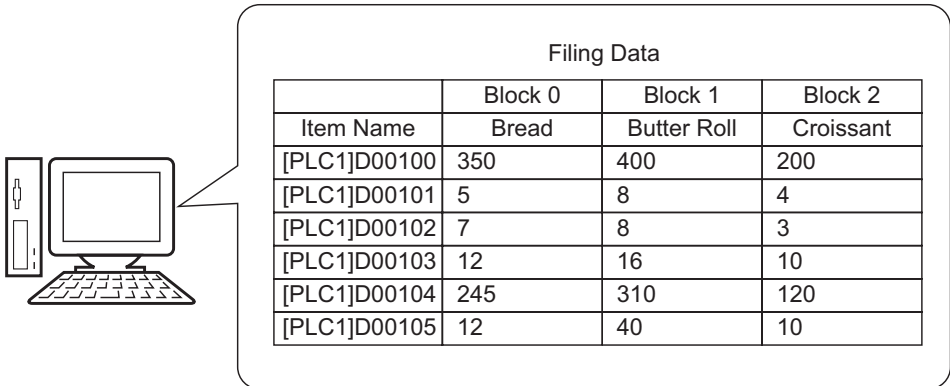

The diagram illustrates the process of creating filing data. On the left, a computer monitor and keyboard are shown. A speech bubble points from the monitor to a table titled "Filing Data".

Filing Data			
	Block 0	Block 1	Block 2
Item Name	Bread	Butter Roll	Croissant
[PLC1]D00100	350	400	200
[PLC1]D00101	5	8	4
[PLC1]D00102	7	8	3
[PLC1]D00103	12	16	10
[PLC1]D00104	245	310	120
[PLC1]D00105	12	40	10

25.7.2 Setup Procedure

-
- NOTE** • Please refer to the settings guide for details.
- ☞ “25.10.1 Recipe Settings Guide ■ Transfer Filing Data (Filing Data List)” (page 25-67)
-

The following shows the operation procedure for registering new filing data, when multiple folders are not used.

- 1 Select the [Common Settings (R)] menu - [Recipe Settings (R)] option - [Transfer Filing Data (Filing Data List) (D)] command. The following screen appears.

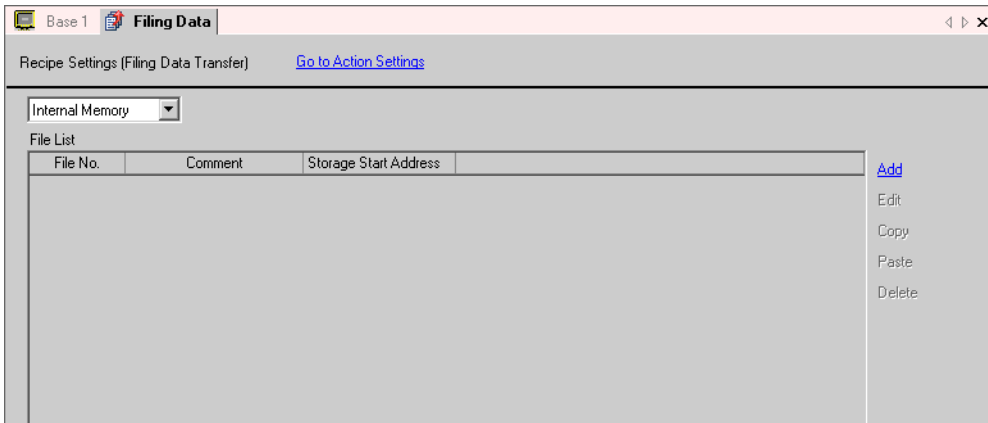

- 2 Set the save location for created filing data to [Internal Memory]. Filing data is stored in the GP internal memory via a screen transfer.

-
- NOTE** • If [CF-Card] is selected, you must set the CF-Card Export Folder. Filing data saved in the CF-card export folder is transferred to the GP’s CF-card via a screen transfer.
-

3 Click [Add]. The [Edit Filing Data] dialog box opens up.

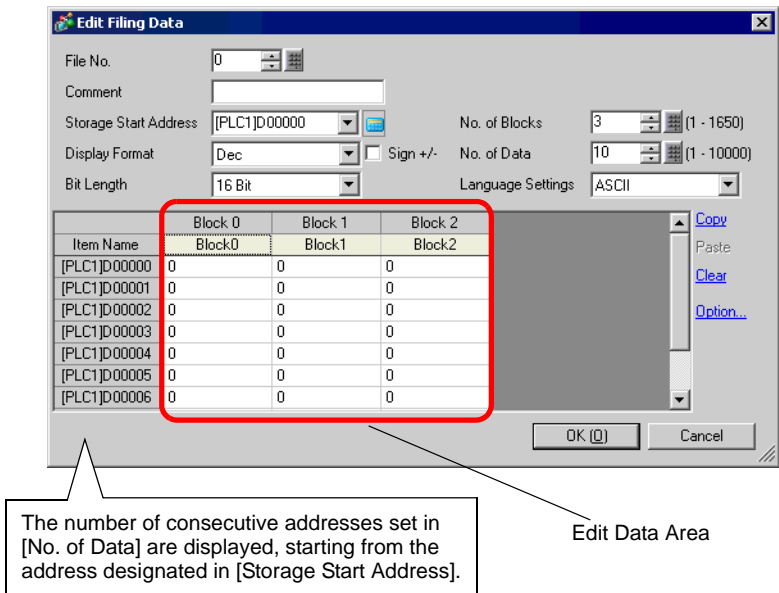

4 In [Storage Start Address], set the start address of the destination (or source) device/PLC. The designated contents are set up in the Edit Data Area. Designate the filing data's [Display Format], [Bit Length] and [Sign +/-].

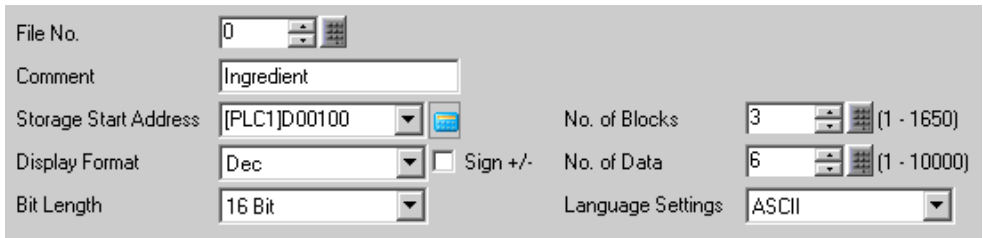

NOTE • If you touch [Option], you can configure setting to transfer data with the item name and block number attached to it.
 ☞ "25.12.2 Transferring Item Name and Block No." (page 25-109)

5 In the Edit Data Area, input each block's (recipe's) item name and data.

	Block 0	Block 1	Block 2
Item Name	Bread	Butter Roll	Croissant
[PLC1]D00100	350	400	200
[PLC1]D00101	5	8	4
[PLC1]D00102	7	8	3
[PLC1]D00103	12	16	10
[PLC1]D00104	245	310	120
[PLC1]D00105	12	40	10

- 6 Click [OK] and the [Edit Filing Data] dialog box closes. The created file is added to the [File List].

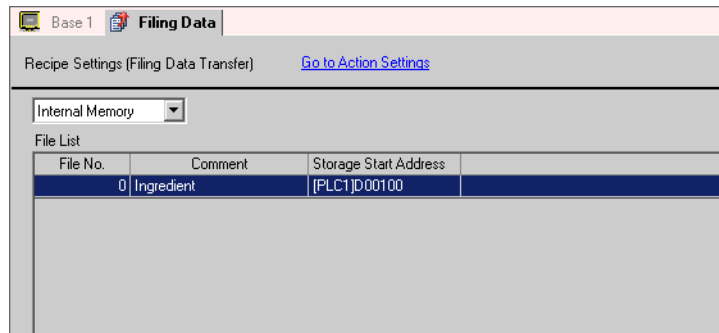

Filing data for File No. “0” is now complete.

25.8 Transferring Recipes (Filing Data) by Touch (Manual Transfer)

25.8.1 Details

The item names of filing data stored in backup SRAM is displayed on the GP screen in a list. Touch to select/deselect the desired blocks' item names, and they are written to the device/PLC.

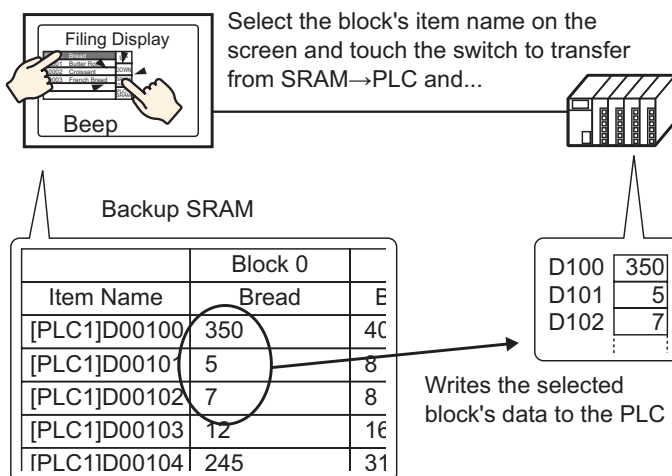

Also, device/PLC data overwrites the selected blocks in backup SRAM.

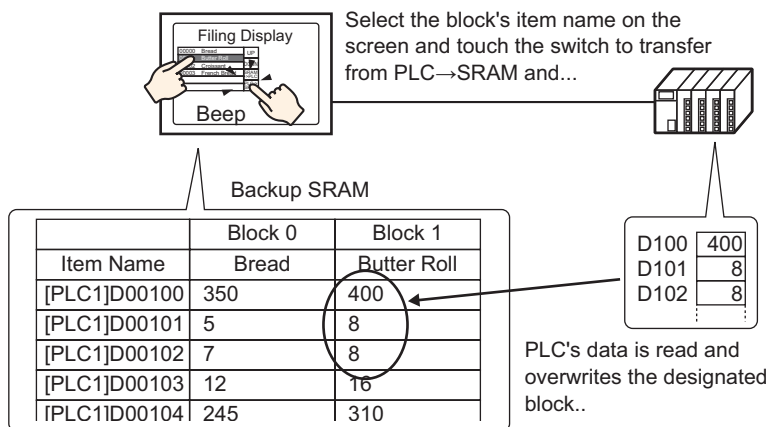

NOTE

- When transferring from device/PLC to backup SRAM, you cannot save as a new block. If you do not want to overwrite existing data, please create an empty block in advance.
- You cannot edit backup SRAM's filing data on the GP screen. When transferring via the internal device, you can edit data stored in the internal device by using a Data Display part.

25.8.2 Setup Procedure

- NOTE**
- Please refer to the settings guide for details.
 - ☞ “25.10.1 Recipe Settings Guide ■ Transfer Filing Data (Mode Settings)” (page 25-63)
 - ☞ “25.10.2 Special Data Display Settings Guide ■ Filing Display” (page 25-78)
 - For details about placing parts or setting addresses, shapes, colors, and labels, please refer to the “Part Editing Procedure”.
 - ☞ “9.6.1 Procedure for Editing a Part” (page 9-36)

On the GP screen’s Special Data Display [Filing], the following settings show how to designate and transfer the blocks’ item names by touching them.

- 1 Select the [Common Settings (R)] menu - [Recipe Settings (R)] option - [Transfer Filing Data (Mode Settings) (A)] command, or click . The following screen will appear.

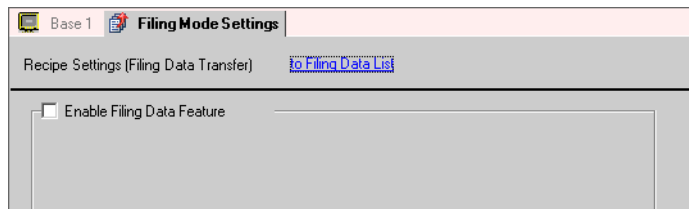

- 2 Put a check mark next to the [Enable Filing Data Feature] box.

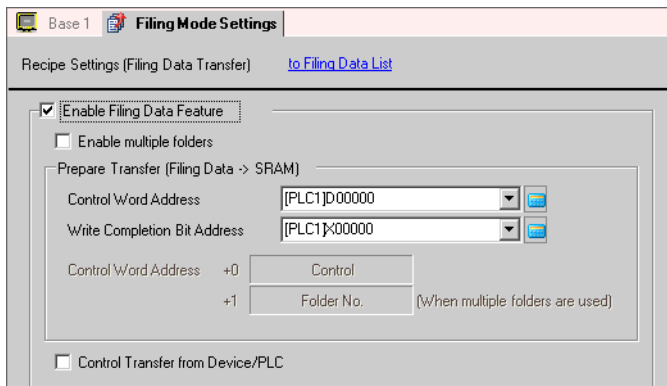

3 In [Control Word Address], set the address (D10) to write filing data stored in the GP internal memory (or CF-card) to backup SRAM. Two consecutive words will automatically be used, starting from the set address.

In [Write Completion Bit Address], set the address (M100) to confirm that writing to backup SRAM is complete.

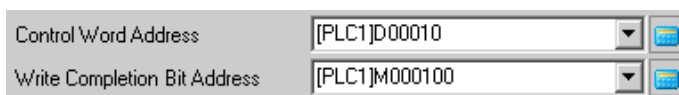

4 Open the screen editor. Select the [Part (P)] menu - [Special Data Display (P)] option - [Filing (F)] command and place the Part on the screen.

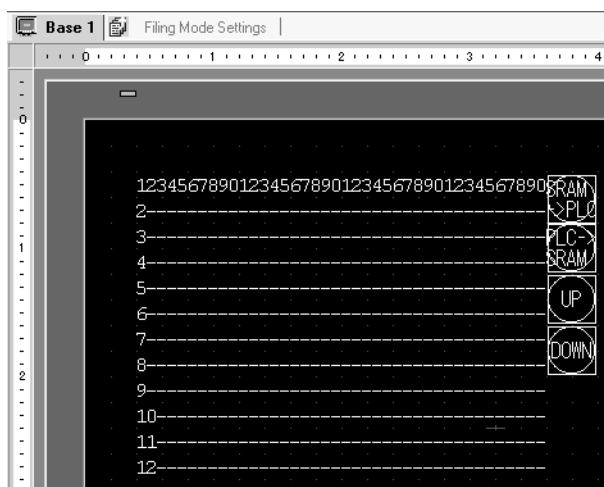

5 Double-click the placed Special Data Display and the settings dialog box opens.

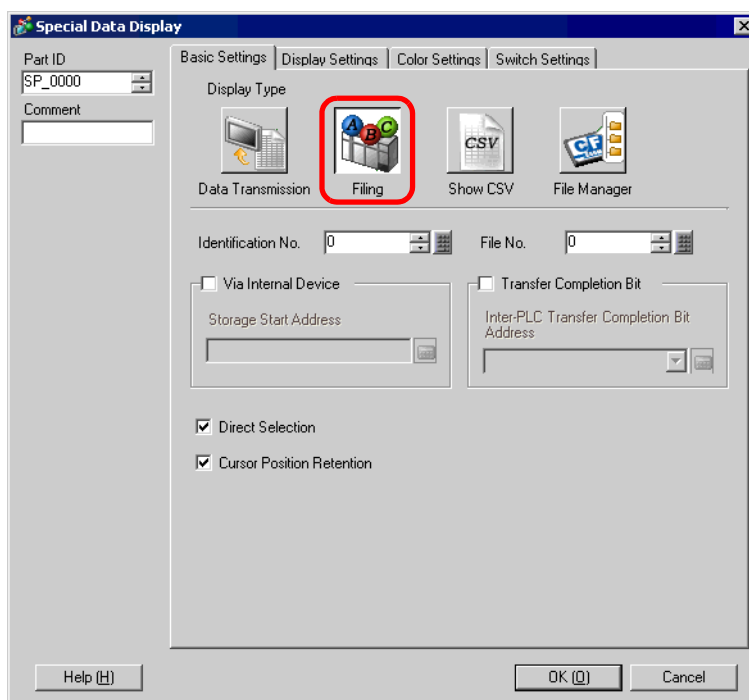

6 In [Identification No.], set the ID number of the Special Data Display [Filing].

- NOTE** • When displaying multiple Special Data Displays [Filing] on the screen, be sure not to use the same [Identification No.] for multiple Displays.

7 In [File No.], set the file number “0” of the Special Data Display [Filing] you want to display. All the item names contained in the file designated here can be displayed in a list and transferred.

8 Select the [Display Settings] tab, and set the font settings and display format.

The screenshot shows the 'Display Settings' tab selected. It contains the following controls:

- Font Settings:**
 - Font Type: Standard Font (dropdown)
 - Size: 8 x 16 dot (dropdown)
- Display Format:**
 - Show Border: Three radio button options with corresponding icons:
 - Hide Border (selected): A dashed border icon.
 - Outer Border: A solid border icon.
 - Outer Border + Horizontal Ruled Line: A solid border with horizontal lines icon.
 - No. of Display Char.: 40 (spin box)
 - No. of Display Lines: 12 (spin box)

9 Select the [Color Settings] tab, and set the text and background color.

The screenshot shows the 'Color Settings' tab selected. It contains the following controls:

- Display Color: 7 (dropdown)
- Background Color: 0 (dropdown)
- Clear Color: 0 (dropdown)
- Blink: Three dropdown menus, all set to 'None'.

- 10 Select the [Switch Settings] tab, and select the operation switches you want to place. Set the number of rows that a scroll switch will scroll when pressed once. Select the switches' shapes, set the label and text color, and click [OK].

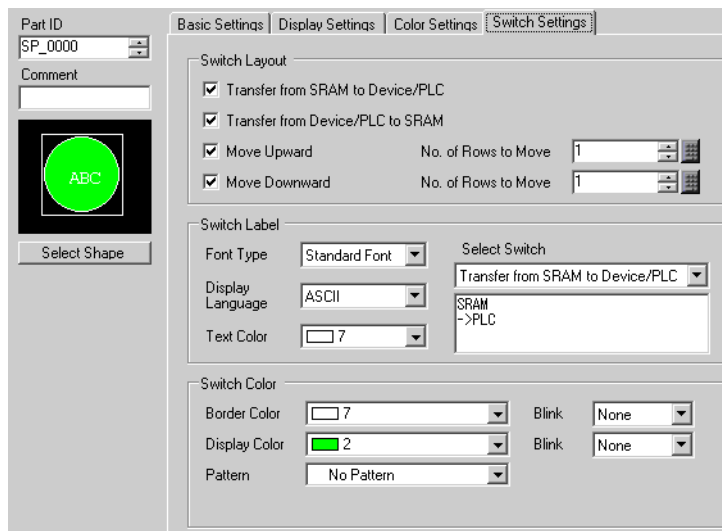

Special Data Display Part [Filing] is now set. You can move the attached [Filing] switches independently to the desired location.

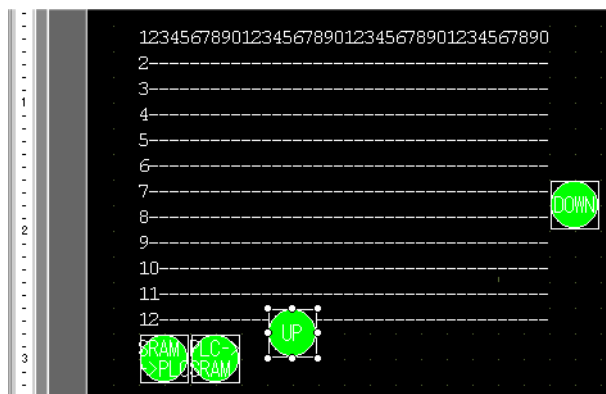

25.8.3 Transfer Process

The following shows the process for manual transfer from backup SRAM to device/PLC.
(When multiple folders are not used.)

- 1 Turn ON D10's bit 0. All the filing data stored in internal memory is transferred to backup SRAM.

NOTE • When filing data is saved in the CF-card, turn ON both bit 0 and bit 8.

- 2 When the data write to backup SRAM has been completed successfully, turn ON the Write Completed Bit (M100). After confirming the bit is ON, turn OFF D10's bit 0 and M100.
- 3 In the Special Data Display [Filing] on the GP screen, the item names of registered blocks in the designated files inside backup SRAM are displayed in a list.
Select the block's item name (1 name) to transfer by touching it. (Selected rows are displayed in reverse color.)
- 4 Touch the SRAM → PLC transfer switch.
The selected blocks' data is transferred to the device/PLC.

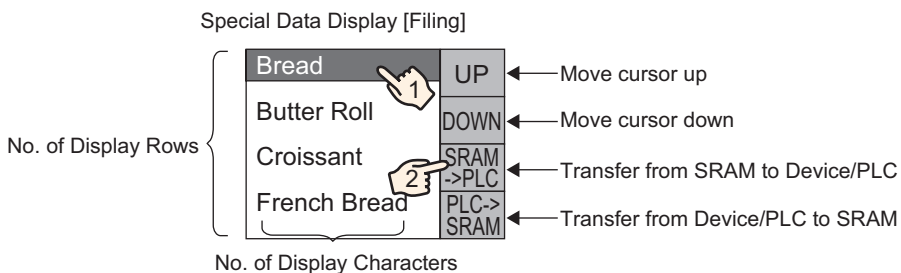

25.9 Transferring Recipes (Filing Data) from a Device/PLC (Automatic Transfer)

25.9.1 Details

Designate the address to control the transfer. When that address turns ON, filing data is transferred between the GP's backup SRAM and a device/PLC.

- Transfer from backup SRAM to device/PLC
Designate the file no./block no. to transfer and turn ON the control address' bit 0. The block's data (recipe) is written to the device/PLC.

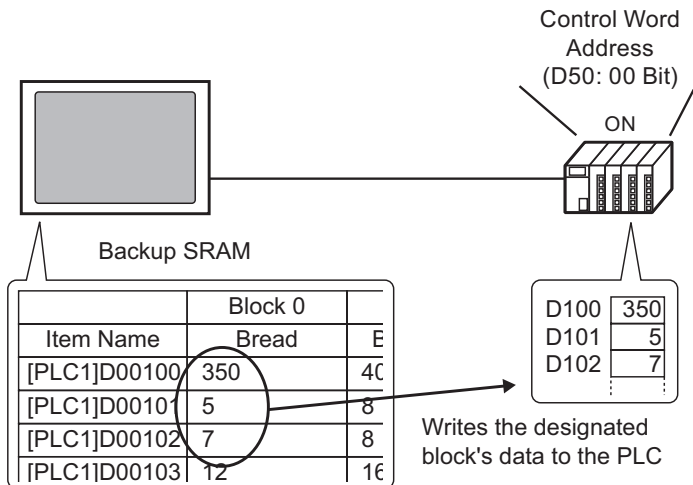

- Transfer from device/PLC to backup SRAM
Designate the file no./block no. to transfer and turn ON the control address' bit 0 and bit 8. Data from the device/PLC is saved to backup SRAM and overwrites the designated blocks.

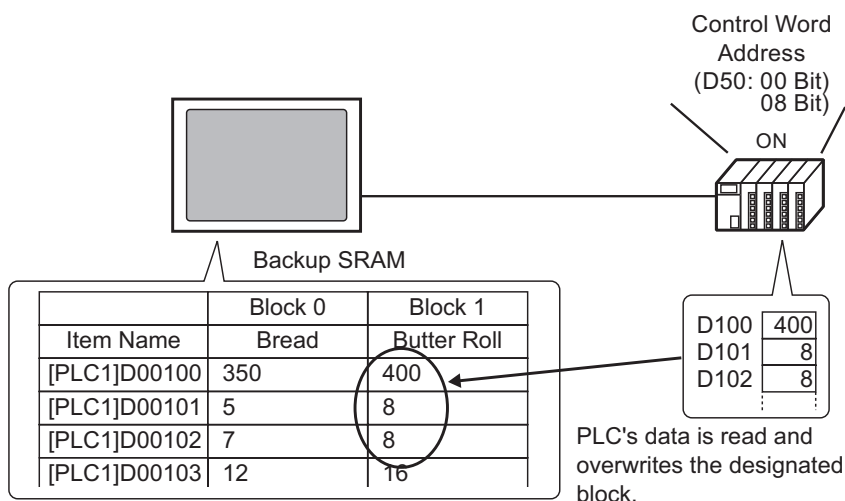

- NOTE** • When transferring from device/PLC to backup SRAM, you cannot save as a new block. If you do not want to overwrite existing data, please create an empty block in advance.

25.9.2 Setup Procedure

- NOTE** • Please refer to the settings guide for details.
 ☞ “25.10.1 Recipe Settings Guide ■ Transfer Filing Data (Mode Settings)” (page 25-63)

Configure settings to designate the file no./block no. and turn ON address D50’s bit 0 and transfer the designated blocks’ data.

- 1 Select the [Common Settings (R)] menu - [Recipe Settings (R)] option - [Transfer Filing Data (Mode Settings) (A)] command, or click . The following screen will appear.

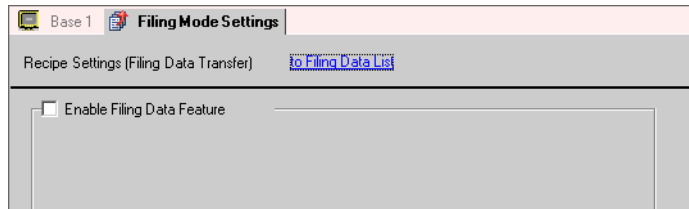

- 2 Put a check mark next to the [Enable Filing Data Feature] box.

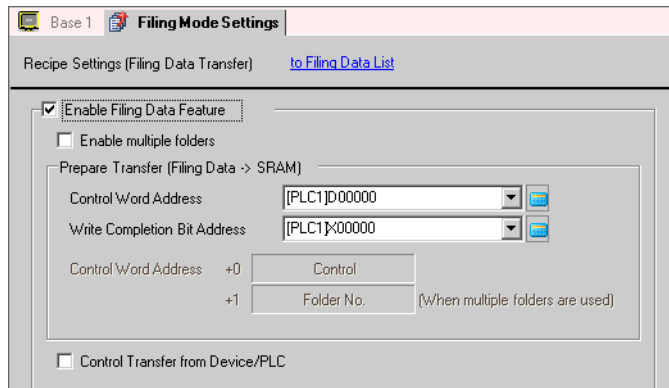

- 3 In [Control Word Address], set the address (D10) to write filing data stored in the GP internal memory (or CF-card) to backup SRAM. Two consecutive words will automatically be used, starting from the set address.

In [Write Completion Bit Address], set the address (M100) to confirm that writing to backup SRAM is complete.

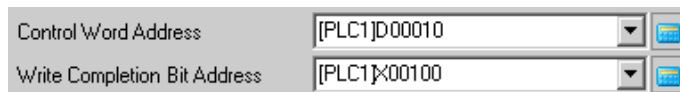

- 4 Put a check mark next to the [Control Transfer from Device/PLC] box. The transfer settings will appear.

Control Transfer from Device/PLC

Transfer Settings (SRAM <-> Device/PLC)

Control Word Address [PLC1]D00000

Transfer Completion Bit Address [PLC1]X00000

Control Word Address +0 Control

+1 File No.

+2 Block No.

- 5 In [Control Word Address], set the address (D50) which will control the transfer between backup SRAM and the device/PLC. Three consecutive words will automatically be used, starting from the set address.
- In [Transfer Completion Bit Address], set the address (M101) used to verify that the transfer is complete.

Control Word Address [PLC1]D00050

Transfer Completion Bit Address [PLC1]M000101

The automatic transfer settings are complete.

25.9.3 Transfer Process

Transfer from SRAM to Device/PLC (When multiple folders are not used.)

The following shows the process to transfer File No. “0”/Block No. “0” to the device/PLC.

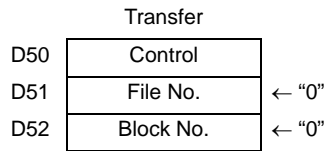

1 Turn ON D10’s bit 0. Filing data stored in internal memory is transferred to backup SRAM.

NOTE • When filing data is saved in the CF-card, turn ON both bit 0 and bit 8.

2 When the data write to backup SRAM has been completed successfully, turn ON the Write Completed Bit (M100). After confirming the bit is ON, turn OFF D10’s bit 0 and M100.

3 In D51, store the File No. “0”.

4 In D52, store the Block (Recipe) No. “0”.

5 Turn ON D50’s bit 0. The designated data in backup SRAM is transferred to the PLC.

6 When the transfer completes successfully, the Transfer Completion Bit (M101) turns ON. After confirming the bit is ON, turn OFF D50’s bit 0 and M101.

Transfer Device/PLC to SRAM

The following shows the process for reading the device/PLC’s data and storing it in File No. “0”/Block No. “1” in backup SRAM.

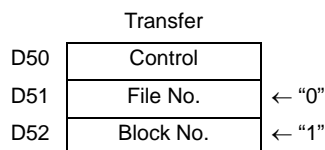

1 In D51, store the File No. “0”.

2 In D52, store the Block (Recipe) No. “1” where data that is read from the device/PLC will be stored.

3 Turn ON D50’s bit 0 and bit 8. Device/PLC’s data will overwrite block 1.

4 When the transfer completes successfully, the Transfer Completion Bit (M101) turns ON. After confirming the bit is ON, turn OFF D50’s bit 0, bit 8, and M101.

25.10 Settings Guide

25.10.1 Recipe Settings Guide

■ Transfer CSV Data (Condition Settings)

Configure condition settings and transfer settings for CSV data.

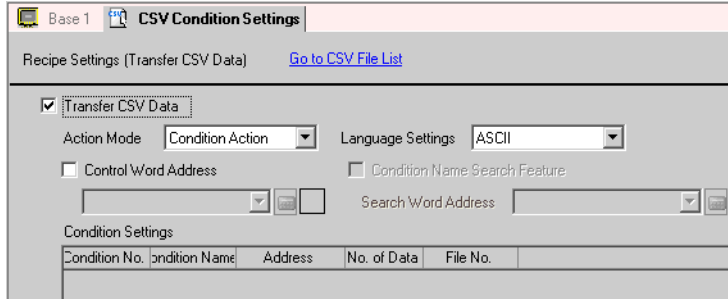

Setting	Description
Transfer CSV Data	Select whether or not to use the Transfer CSV Data feature.
Action Mode	<p>Select the CSV data's transfer action.</p> <p>NOTE</p> <ul style="list-style-type: none"> When using a Special Data Display [Data Transmission] and transferring (manual transfer), please select [Condition Action]. Condition Action The transfer is executed according to the condition set in [Condition Settings], such as destination address, No. of Data, etc. Multiple CSV data can be transferred at one time. Address Action The transfer destination (and source) address is designated at transfer time. Change the address for each file and transfer the CSV data.

Continued

Setting	Description																																																								
Control Word Address	<p>Designate whether or not to operate the CSV data transfer from the device/PLC (automatic transfer). If designated, set the address to control the transfer.</p> <p>The contents of the set address differ depending on the [Action Mode] settings.</p> <p>☞ “25.11.2 Control Word Address” (page 25-90)</p> <table border="1" data-bbox="436 390 1223 807"> <thead> <tr> <th colspan="2">Condition Action</th> <th colspan="2">Address Action</th> </tr> </thead> <tbody> <tr> <td>Control Word Address</td> <td>Control</td> <td>Control Word Address</td> <td>Control</td> </tr> <tr> <td>+1</td> <td>Status</td> <td>+1</td> <td>Status</td> </tr> <tr> <td>+2</td> <td>No. of Files (n)</td> <td>+2</td> <td>No. of Files</td> </tr> <tr> <td>+3</td> <td>File No. 1</td> <td>+3</td> <td>Mode</td> </tr> <tr> <td>+4</td> <td>File No. 2</td> <td>+4</td> <td>Device Code</td> </tr> <tr> <td>+5</td> <td></td> <td>+5</td> <td>•</td> </tr> <tr> <td></td> <td></td> <td>+6</td> <td>Address Code</td> </tr> <tr> <td></td> <td></td> <td>+7</td> <td>(4 words)</td> </tr> <tr> <td>+2+n</td> <td>File No. n</td> <td>+8</td> <td>No. of Data</td> </tr> <tr> <td></td> <td></td> <td>+9</td> <td></td> </tr> <tr> <td></td> <td></td> <td></td> <td>Reserved Area</td> </tr> <tr> <td></td> <td></td> <td></td> <td>(7 words)</td> </tr> <tr> <td></td> <td></td> <td>+15</td> <td></td> </tr> </tbody> </table>	Condition Action		Address Action		Control Word Address	Control	Control Word Address	Control	+1	Status	+1	Status	+2	No. of Files (n)	+2	No. of Files	+3	File No. 1	+3	Mode	+4	File No. 2	+4	Device Code	+5		+5	•			+6	Address Code			+7	(4 words)	+2+n	File No. n	+8	No. of Data			+9					Reserved Area				(7 words)			+15	
Condition Action		Address Action																																																							
Control Word Address	Control	Control Word Address	Control																																																						
+1	Status	+1	Status																																																						
+2	No. of Files (n)	+2	No. of Files																																																						
+3	File No. 1	+3	Mode																																																						
+4	File No. 2	+4	Device Code																																																						
+5		+5	•																																																						
		+6	Address Code																																																						
		+7	(4 words)																																																						
+2+n	File No. n	+8	No. of Data																																																						
		+9																																																							
			Reserved Area																																																						
			(7 words)																																																						
		+15																																																							
Language Settings	<p>Choose a language for the condition name from [ASCII], [Japanese], [Taiwanese], [Chinese], or [Korean]. The condition name will be displayed on the Special Data Display [Data Transmission] according to this setting.</p>																																																								
Condition Name Search Feature	<p>When the [Action Mode] is [Condition Action] and automatic transfer is used, designate whether or not to use the Condition Name Search feature. The Condition Name Search feature is used to search for the CSV you want to send by condition name, and write all matching files from CF-card to device/PLC.</p> <p>☞ “25.11.3 Condition Name Search Feature” (page 25-98)</p>																																																								
Search Word Address	<p>When using the Condition Name Search feature, designate a word address in order to store the text to search.</p> <p>This can be set to either a device/PLC address or GP internal device address.</p> <p>The lower 16 words of the address designated here (or 8 words for a 32 bit address) are used, and they store the condition name of the file you want to transfer. The condition search name can be up to 32 single-byte characters long.</p> <p>The file whose condition name matches the stored string will be detected in the CF-card and transferred.</p> <p>☞ “25.11.3 Condition Name Search Feature ◆ Condition Name Search Storing Methods” (page 25-102)</p>																																																								

Continued

Setting	Description									
Search Word Address	<p>NOTE</p> <ul style="list-style-type: none"> The search is only possible when the search string is a perfect match for the condition name. Please be careful about errors caused by spaces. When data transfer is completed, the status is reflected at the same time as the number of transferred files and the last transferred file number are written in the GP internal device's Special Area LS9200 and LS9201. (The Special Areas are read-only.) <p style="text-align: center;">LS Area</p> <table style="margin-left: auto; margin-right: auto;"> <tr> <td style="padding-right: 10px;">LS9200</td> <td style="border: 1px solid black; width: 100px; height: 20px;"></td> <td style="padding-left: 10px;">No. of transferred CSV files</td> </tr> <tr> <td>LS9201</td> <td style="border: 1px solid black; width: 100px; height: 20px;"></td> <td>File No. of last transferred CSV file</td> </tr> <tr> <td></td> <td style="border: 1px solid black; width: 100px; height: 20px;"></td> <td></td> </tr> </table>	LS9200		No. of transferred CSV files	LS9201		File No. of last transferred CSV file			
LS9200		No. of transferred CSV files								
LS9201		File No. of last transferred CSV file								
Device/PLC at Transfer Address	When [Action Mode] is [Address Action], select the device/PLC for transfer.									
Condition List	The contents of registered conditions are displayed in a list.									
Create	Create a new condition. When clicked, the [CSV Data Transfer Condition Settings] dialog box opens up.									
Edit	Edit the condition selected in the [Condition List]. When clicked, the [CSV Data Transfer Condition Settings] dialog box opens up.									
Copy	Copy the condition selected in the [Condition List].									
Paste	Add the copied condition into the [Condition List].									
Delete	Delete the condition selected in the [Condition List].									
Duplication Check	Ensure that the file number settings for the condition have not been duplicated. If file numbers are repeated in several conditions, data will be transferred according to the condition with the smaller number.									

◆ [CSV Data Transfer Condition Settings] dialog box

Condition Settings

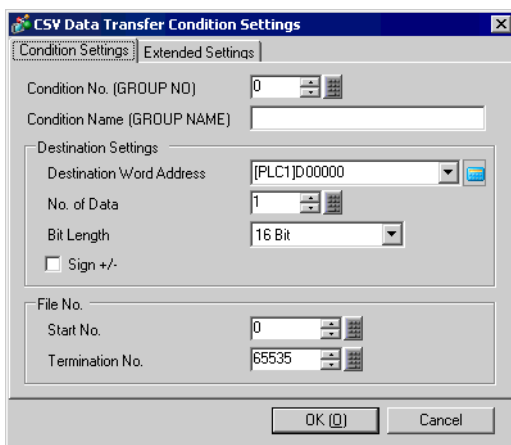

Setting		Description
Condition No. (GROUP NO)		Designate the condition number. The value can be from 0 to 1,023. Assign each conditions its own unique number.
Condition Name (GROUP NAME)		Condition names can be a maximum of 32 characters. When transferring from device/PLC to CF-card, the CSV file's condition name will become the name designated here.
Destination Settings	Destination Word Address	The specified address will function as the destination address (or as the source address when transferring PLC→CF-card). An internal device address can also be set.
	No. of Data	Select the number of data items to be transferred from 1 to 10,000 (or 1 to 5,000 for 32 bit). NOTE • If you set more than 5,000 data items when the [Bit Length] is [32 Bit], the transfer process will not be executed.
	Bit Length	Choose the bit length from [16 Bit] or [32 Bit].
	Sign +/-	Designate whether or not negative numbers will be allowed.
File No.	Start No./ Termination No.	Designate the file range to register as a single condition with file numbers. The value can be from 0 to 65,535. All the files from [Start No.] to [Termination No.] will become part of the same condition's group. NOTE • Please do not set the same file number to multiple conditions. If file numbers are repeated in several conditions, the files will be transferred according to the condition with the smallest number.

Extended Settings

When using automatic transfer from device/PLC to CF-card, you can automatically allot the file numbers and create new files. (This has no effect for manual transfer or automatic transfer from CF-card to device/PLC.)

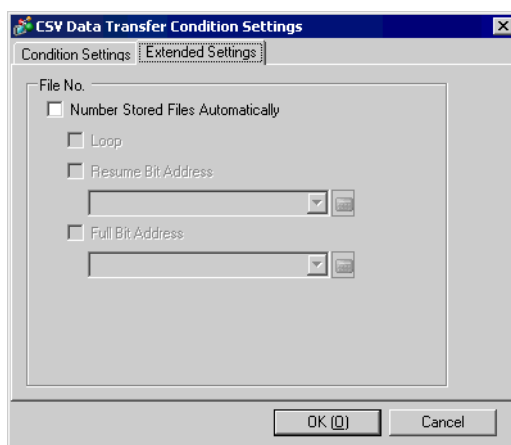

Setting	Description
Number Stored Files Automatically	Select whether or not to enable automatic numbering mode, under which the file number increments automatically when reading data from the device/PLC and saving it to the CF-card as a CSV file. Numbering will occur until the designated [Termination No.]. After that, it cannot transfer. To overwrite existing files and continue transferring, use [Loop] or [Resume Bit Address]. ☞ "25.11.4 Automatic Numbering" (page 25-104)
Loop	Designate whether or not to enable the loop action. If enabled, when the File No. reaches the designated [Termination No.], the oldest file is deleted and files are overwritten in order beginning with [Start No.] when a new file is created.
Resume Bit Address	Designate whether or not to set a bit address to resume transmission when the file number has reached the designated [Termination No.]. When this bit address is turned ON, after the [Control Word Address] is turned ON, files will be created (overwritten) beginning from the designated [Start No.].
Full Bit Address	This bit confirms whether or not the file number has reached the designated [Termination No.]. This bit address turns ON when File No. reaches the [Termination No.].

■ Transfer CSV Data (CSV File List)

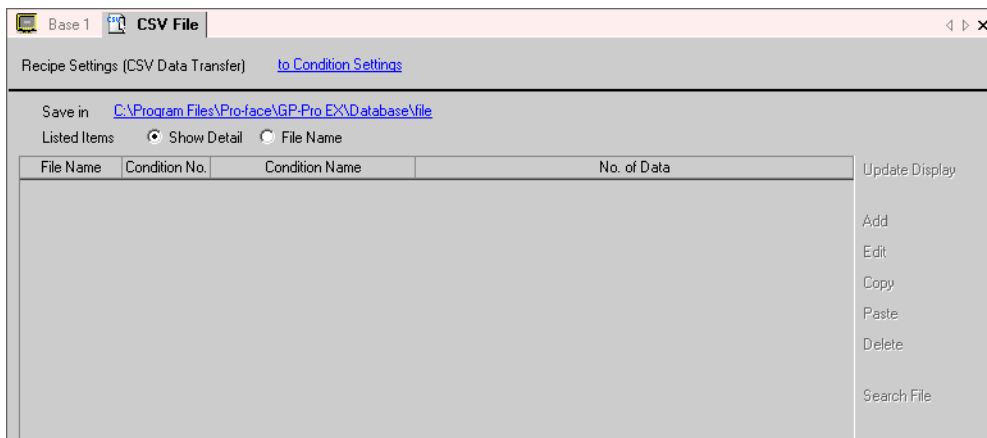

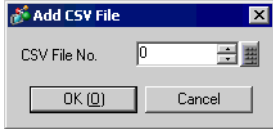
Setting	Description
File Save Location (CF-Card Output Folder)	The designated CSV file's save location is displayed. The designated CSV data is saved here, and transferred to the CF-card during the screen transfer.
Listed Items	Select the contents displayed in the [CSV File List]. <ul style="list-style-type: none"> • Show Detail Condition Name and No. of Data settings are displayed along with the file name. • File Name Only the file name is displayed.
CSV File List	CSV files registered in GP-Pro EX are displayed in a list.
Update Display	Update the contents in [CSV File List].
Add	Register a new file. The file number can be any number from 0 to 65,535 that is not yet registered. Click [OK] and the [Edit CSV File] dialog box is displayed. <div style="text-align: center;">  </div>
Edit	Open the [Edit CSV File] dialog box to edit the content and condition of the file chosen in [CSV File List]. ☞ “◆ [Edit CSV File] dialog box” (page 25-62)
Copy	Copy the file selected in [CSV File List].
Paste	Add the copied file into [CSV File List]. The file number can be any number from 0 to 65,535 that is not yet registered.
Delete	Delete the file selected in [CSV File List].

◆ [Edit CSV File] dialog box

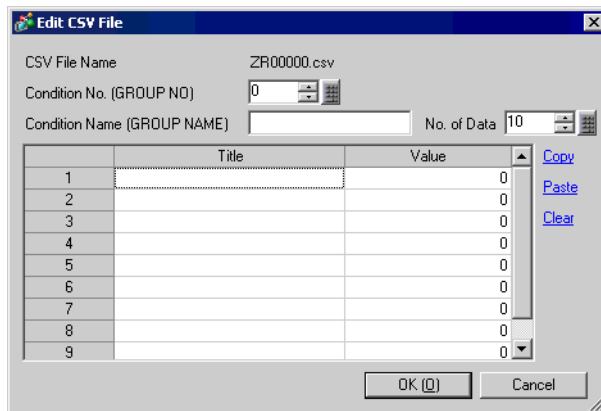

Setting	Description
Condition No. (GROUP NO)	Set the selected file's condition no. The value can be from 0 to 1,023.
Condition Name (GROUP NAME)	Set the selected file's condition name with a maximum of 32 single-byte characters. When a Special Data Display [Data Transmission] is placed, the condition name set here will be displayed.
No. of Data	Set the number of recipes data items from 1 to 10,000 (or from 1 to 5,000 when data is 32 bit). NOTE <ul style="list-style-type: none"> If you set more than 5,000 data items when the [Bit Length] is [32 Bit], the transfer process will not be executed.
Edit Data Area	Input the recipe's (material's) title and data. The title set here will not be transferred to the device/PLC.
Copy	Copy the contents of the currently selected cell in the [Edit Data Area].
Paste	Paste the copied contents into the selected cell.
Clear	Delete the contents of the currently selected cell in the [Edit Data Area].

■ Transfer Filing Data (Mode Settings)

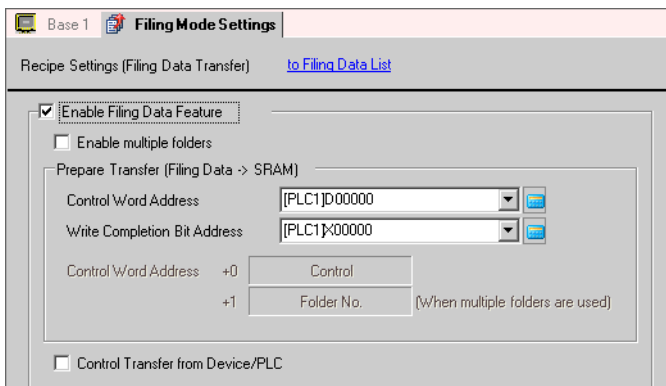

Setting		Description																																															
Enable Filing Data Feature		Select whether or not to transfer filing data.																																															
Enable multiple folders		Specify whether or not to create multiple folders.																																															
Prepare Transfer (Filing Data → SRAM)	Control Word Address	<p>Designate the word address which will write filing data to backup SRAM. When this address' bit 0 turns ON, the data write to SRAM begins. The transfer source is designated in bit 8.</p> <div style="text-align: center;"> <table border="1" style="margin: auto;"> <tr> <td style="width: 50px; text-align: center;">15</td> <td style="width: 50px;"></td> <td style="width: 50px; text-align: center;">9</td> <td style="width: 50px; text-align: center;">8</td> <td style="width: 50px; text-align: center;">7</td> <td style="width: 50px;"></td> <td style="width: 50px; text-align: center;">1</td> <td style="width: 50px; text-align: center;">0</td> </tr> <tr> <td colspan="3" style="text-align: center;">Reserved (0)</td> <td style="text-align: center;"> </td> <td colspan="3" style="text-align: center;">Reserved (0)</td> <td style="text-align: center;"> </td> </tr> <tr> <td colspan="4"></td> <td style="text-align: center;">Mode</td> <td colspan="4"></td> </tr> <tr> <td colspan="4"></td> <td style="text-align: center;">[0] Internal Memory→SRAM</td> <td colspan="4"></td> </tr> <tr> <td colspan="4"></td> <td style="text-align: center;">[1] CF-Card→SRAM</td> <td colspan="4"></td> </tr> </table> <p>[0]→[1] Write to SRAM</p> <p>IMPORTANT</p> <ul style="list-style-type: none"> This address will not be turned OFF automatically. After the [Write Completion Bit Address] turns ON, please turn OFF bit 0. When using multiple folders, 2 words will be automatically used starting from the designated address. <p>Store the folder number to write to backup SRAM, then turn ON the control address' bit 0. Only one folder can be stored in backup SRAM.</p> <div style="text-align: center;"> <table border="1" style="margin: auto;"> <tr> <td style="width: 50px;">Control Word Address</td> <td style="width: 50px; text-align: center;">Control</td> </tr> <tr> <td style="text-align: center;">+1</td> <td style="text-align: center;">Folder No.</td> </tr> </table> </div> </div>	15		9	8	7		1	0	Reserved (0)				Reserved (0)								Mode									[0] Internal Memory→SRAM									[1] CF-Card→SRAM					Control Word Address	Control	+1	Folder No.
	15		9	8	7		1	0																																									
Reserved (0)				Reserved (0)																																													
				Mode																																													
				[0] Internal Memory→SRAM																																													
				[1] CF-Card→SRAM																																													
Control Word Address	Control																																																
+1	Folder No.																																																
Write Completion Bit Address	<p>Designate a specific Bit Address to verify when the data write to GP backup SRAM is completed. When filing data is stored normally in backup SRAM, this bit turns ON. After confirming completion, please turn OFF this bit.</p> <p>IMPORTANT</p> <ul style="list-style-type: none"> If data cannot be transmitted to backup SRAM due to insufficient memory, the GP internal device's LS2032 bit 9 will be turned ON. 																																																

Continued

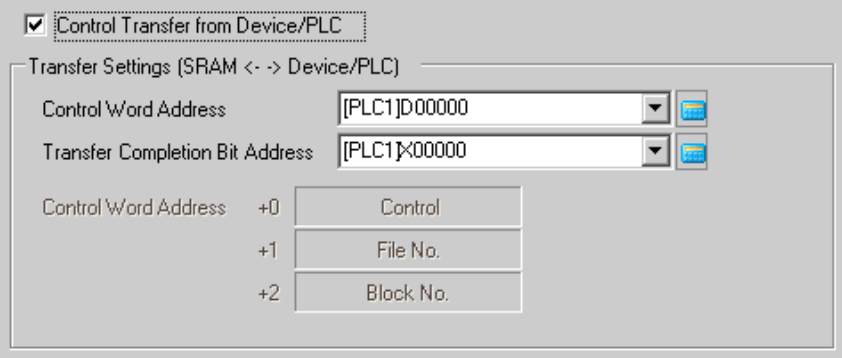
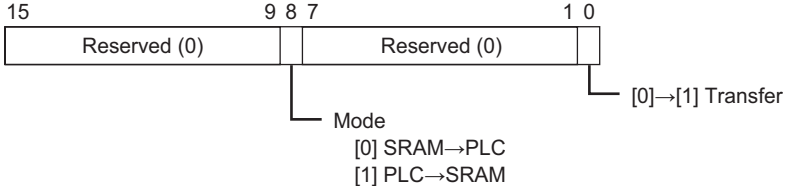
Setting	Description						
<p>Control Transfer from Device/PLC</p>	<p>Designate whether or not the filing data transfer will be controlled by the device/PLC (automatic transfer).</p>  <p>NOTE</p> <ul style="list-style-type: none"> For manual transfer, this setting is not needed. 						
<p>Transfer Settings (SRAM ↔ Device/PLC)</p> <p>Control Word Address</p>	<p>Set the word address which will control the transfer between backup SRAM and the device/PLC. Three consecutive words will automatically be used, starting from the designated address.</p> <table border="1" data-bbox="856 875 1033 971"> <tr> <td>Control Word Address</td> <td>Control</td> </tr> <tr> <td>+1</td> <td>File No.</td> </tr> <tr> <td>+2</td> <td>Block No.</td> </tr> </table> <p>After designating the File No./Block No., when this address' bit 0 turns ON, the transfer starts. The transfer destination is designated in bit 8.</p>  <p>IMPORTANT</p> <ul style="list-style-type: none"> This address will not be turned OFF automatically. After confirming that the [Transfer Completion Bit Address] is ON, please turn OFF bit 0. 	Control Word Address	Control	+1	File No.	+2	Block No.
Control Word Address	Control						
+1	File No.						
+2	Block No.						
<p>Transfer Completion Bit Address</p>	<p>Designate a bit address to verify when the data transfer between backup SRAM and the PLC is completed. When the transfer completes successfully, this bit turns ON. After confirming completion of the transfer, please turn OFF this bit.</p> <p>IMPORTANT</p> <ul style="list-style-type: none"> If data transmission cannot be performed between backup SRAM and the device/PLC, the GP internal device's LS2032 bit 10 is turned ON. 						

Transfer Preparation Timing Chart

When the designated [Control Word Address]’s bit 0 turns ON and filing data is correctly stored in backup SRAM, the [Write Completion Bit Address] will turn ON. After confirming completion, please turn OFF this address.

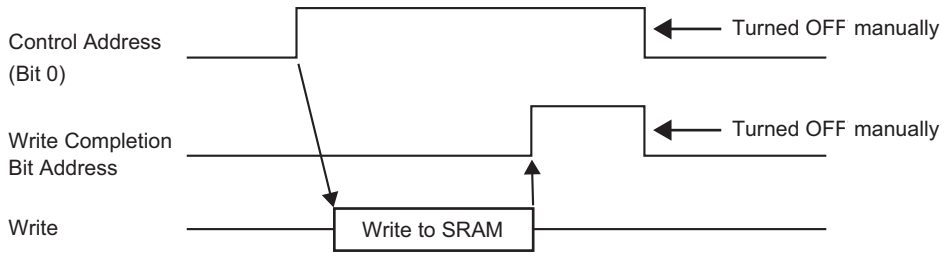

If data cannot be transmitted to backup SRAM due to insufficient memory, the internal device’s (Special Relay Area’s) LS2032 bit 9 will be turned ON. To transfer data again, turn OFF the [Control Word Address]’s bit 0 temporarily, then after setting the communication cycle time as either your standard communication cycle time or 150ms, whichever is longer, turn it ON.

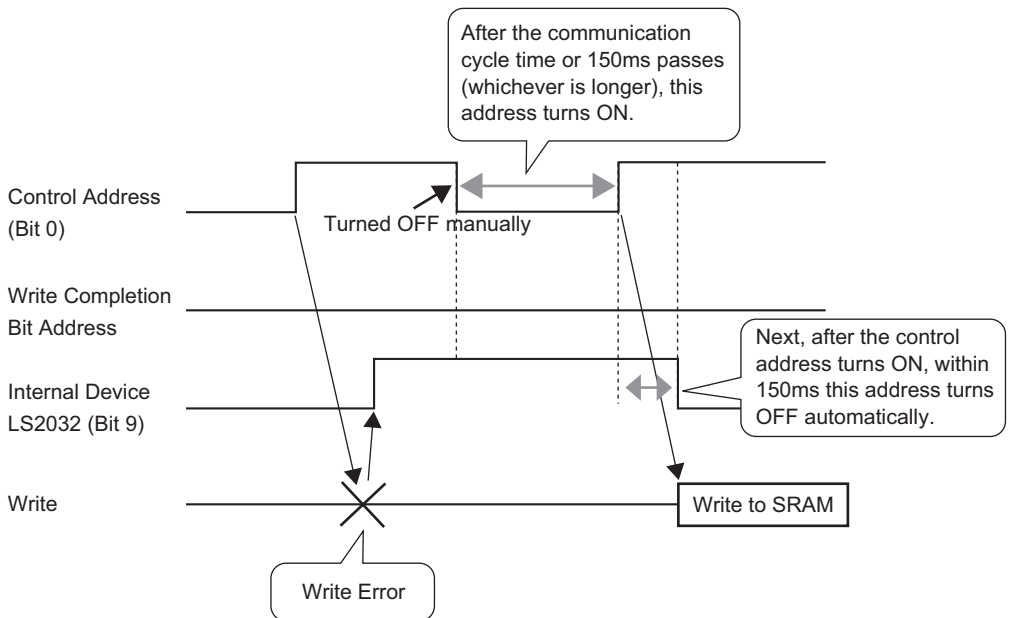

Automatic Transfer Timing Chart

When the designated [Control Word Address]’s bit 0 turns ON and filing data is correctly transferred, the [Transfer Completion Bit Address] will turn ON. After confirming completion, please turn OFF this address.

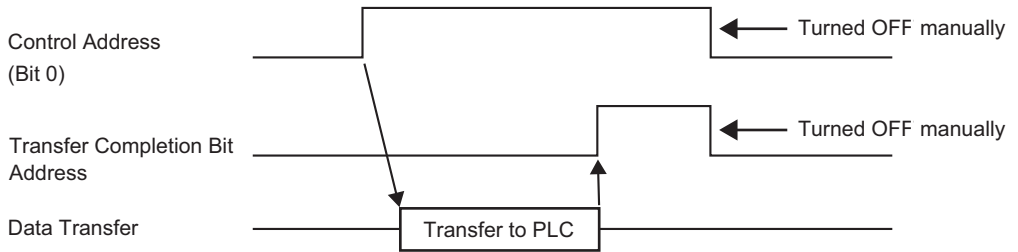

If data cannot be transmitted between the PLC and backup SRAM (a communication error occurs, etc.), the internal device’s (Special Relay Area’s) LS2032 bit 10 will be turned ON. To transfer data again, turn OFF the [Control Word Address]’s bit 0 temporarily, then after setting the communication cycle time as either your standard communication cycle time or 150ms, whichever is longer, turn it ON.

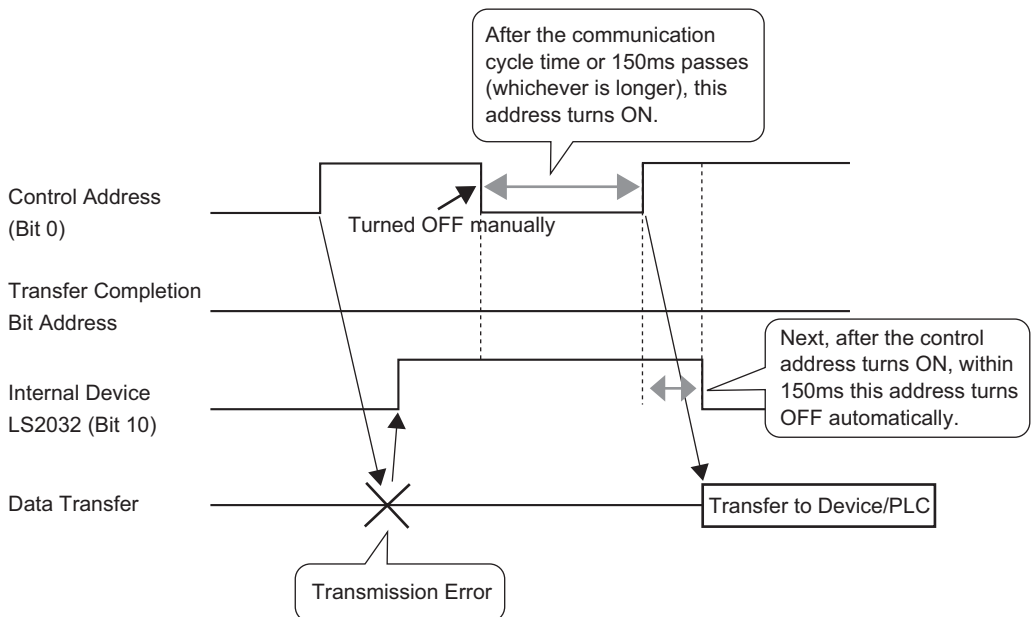

■ Transfer Filing Data (Filing Data List)

When multiple folders are not used

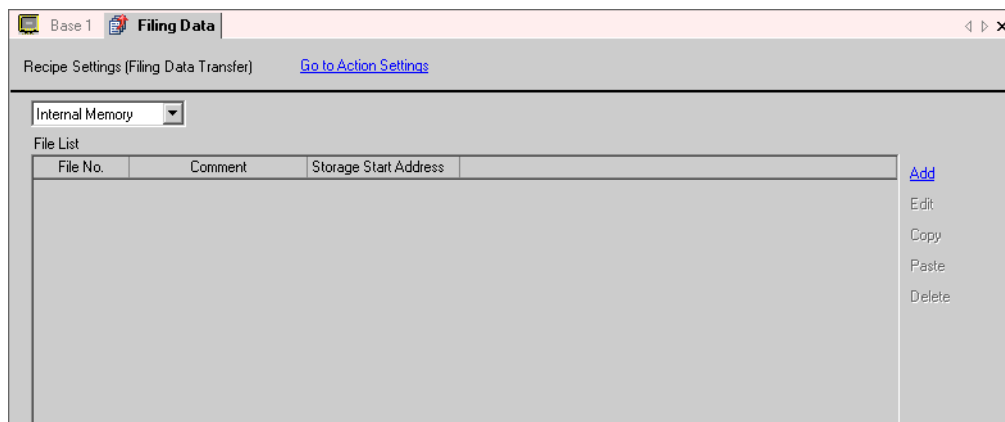

Setting	Description
Save in	Select whether to save created filing data in the GP's [Internal Memory] or the [CF-Card] when transferring screens. If [CF-Card] is selected, you must set the CF-Card Export Folder. Created filing data is saved in the set CF-card export folder.
File List	Displays a list of File No. and Storage Start Address of filing data saved to internal memory or the CF-card.
Update Display	If the [Save in] location is [CF-Card], updates the contents of the [File List].
Add	Register new filing data to be saved in the internal memory or the CF-card. Click it and the [Edit Filing Data] dialog box opens up. ☞ “◆ [Edit Filing Data] dialog box” (page 25-69)
Edit	Edit the file selected in [File List]. Click it and the [Edit Filing Data] dialog box opens up.
Copy	Copy the file selected in [File List].
Paste	Add the copied file into a new file in [File List]. The smallest available file number will be automatically allotted to the new file.
Delete	Delete the file selected in [File List].

When multiple folders are used

In the [Common Settings] menu - [Recipe Settings] - [Transfer Filing Data (Mode Settings)], if there is a check mark next to the [Enable multiple folders] box, the [Folder List] will be displayed.

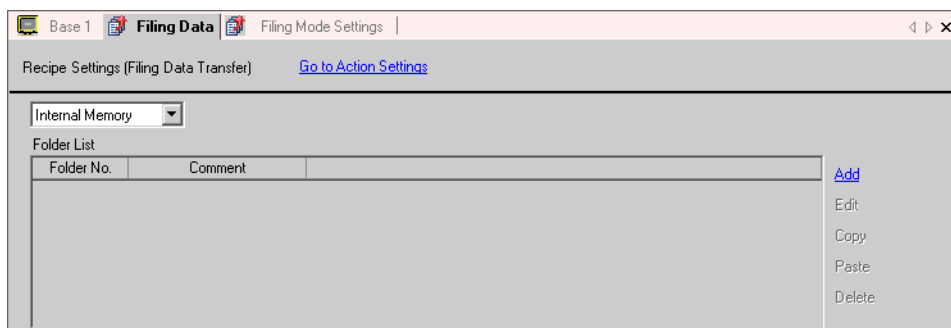

Setting	Description
Folder List	The folder number (the ***** portion in the file name “F*****.bin”) of filing data saved in internal memory or the CF-card is displayed in a list.
Add	<p>Register a new folder to be saved in the internal memory or the CF-card. When clicked, the [Add Folder] dialog box opens up.</p> <div style="text-align: center;"> </div> <ul style="list-style-type: none"> • Folder No. Set the folder number (the ***** portion in the file name “F*****.bin”) from 1 to 8,999. Designate an unused number. • Comment Set a folder title of up to 30 characters.
Edit	Edit the folder number and comment of the folder selected in [Folder List].
Copy	Copy the folder selected in [Folder List].
Paste	Add the copied folder into a new folder in [Folder List].
Delete	Delete the folder selected in [Folder List].

◆ [Edit Filing Data] dialog box

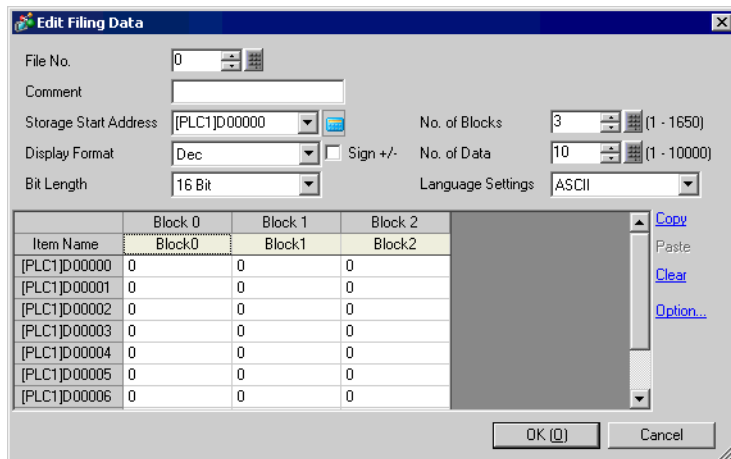

Setting	Description
File No.	Designate an unused file number that falls within the set range. The value can be from 0 to 2,047.
Comment	Set a comment of up to 32 characters.
Storage Start Address	In [Storage Start Address], set the start address of the destination (or source) device/PLC.
Display Format	Choose the data's display format from [Dec], [BCD], or [Hex].
Sign +/-	Specify whether or not negative numbers will be handled. This can only be set when the [Display Format] is [Dec].
Bit Length	Choose the data's bit length from [16 Bit] or [32 Bit].
No. of Blocks	Set the number of blocks (recipes) to register in the file. Up to 1,650 blocks can be saved in one file. The number of blocks that can be set depends on the [No. of Data].
No. of Data	Set the number of data items per block. The number of data items can be a maximum of 10,000 (or 5,000 when the data is 32 bit). The number of data items that can be set depends on the [No. of Blocks].
Language Settings	Select the language to handle the filing data's item names from [ASCII], [Japanese], [Taiwanese], [Chinese], or [Korean]. The item name will be displayed on the Special Data Display [Filing] according to this setting.

Continued

Setting	Description																												
Edit Data Area	<p>In each block, input the recipe's title and data. The data's range depends on the [Bit Length] and [Sign +/-].</p> <table border="1" data-bbox="415 253 1236 591"> <thead> <tr> <th>Bit Length</th> <th>Data Type</th> <th>Sign +/-</th> <th>Input Range</th> </tr> </thead> <tbody> <tr> <td rowspan="4">16 Bit</td> <td rowspan="2">Dec</td> <td>Unchecked</td> <td>0 to 65,535</td> </tr> <tr> <td>Checked</td> <td>-32,768 to 32,767</td> </tr> <tr> <td>Hex</td> <td>—</td> <td>0 to FFFF(h)</td> </tr> <tr> <td>BCD</td> <td>—</td> <td>0 to 9,999</td> </tr> <tr> <td rowspan="4">32 Bit</td> <td rowspan="2">Dec</td> <td>Unchecked</td> <td>0 to 4,294,967,295</td> </tr> <tr> <td>Checked</td> <td>-2,147,483,648 to 2,147,483,647</td> </tr> <tr> <td>Hex</td> <td>—</td> <td>0 to FFFFFFFF(h)</td> </tr> <tr> <td>BCD</td> <td>—</td> <td>0 to 99,999,999</td> </tr> </tbody> </table>	Bit Length	Data Type	Sign +/-	Input Range	16 Bit	Dec	Unchecked	0 to 65,535	Checked	-32,768 to 32,767	Hex	—	0 to FFFF(h)	BCD	—	0 to 9,999	32 Bit	Dec	Unchecked	0 to 4,294,967,295	Checked	-2,147,483,648 to 2,147,483,647	Hex	—	0 to FFFFFFFF(h)	BCD	—	0 to 99,999,999
Bit Length	Data Type	Sign +/-	Input Range																										
16 Bit	Dec	Unchecked	0 to 65,535																										
		Checked	-32,768 to 32,767																										
	Hex	—	0 to FFFF(h)																										
	BCD	—	0 to 9,999																										
32 Bit	Dec	Unchecked	0 to 4,294,967,295																										
		Checked	-2,147,483,648 to 2,147,483,647																										
	Hex	—	0 to FFFFFFFF(h)																										
	BCD	—	0 to 99,999,999																										
Copy	Copy the data from the cell currently selected in the [Edit Data Area].																												
Paste	Paste the copied data into the selected cell.																												
Clear	Delete the data in the cell currently selected in the [Edit Data Area].																												
Option	<p>Opens the [Option Settings] dialog box. Configure settings about whether or not to transfer Item Names and Block No.s with the data.</p> <p>☞ "25.12.2 Transferring Item Name and Block No." (page 25-109)</p> <div data-bbox="657 855 982 1110" data-label="Image"> </div> <ul style="list-style-type: none"> • Send Item Names Select whether or not to transfer the item names when data transfers. • Send Block No. Select whether or not to transfer the block numbers when data transfers. 																												

25.10.2 Special Data Display Settings Guide

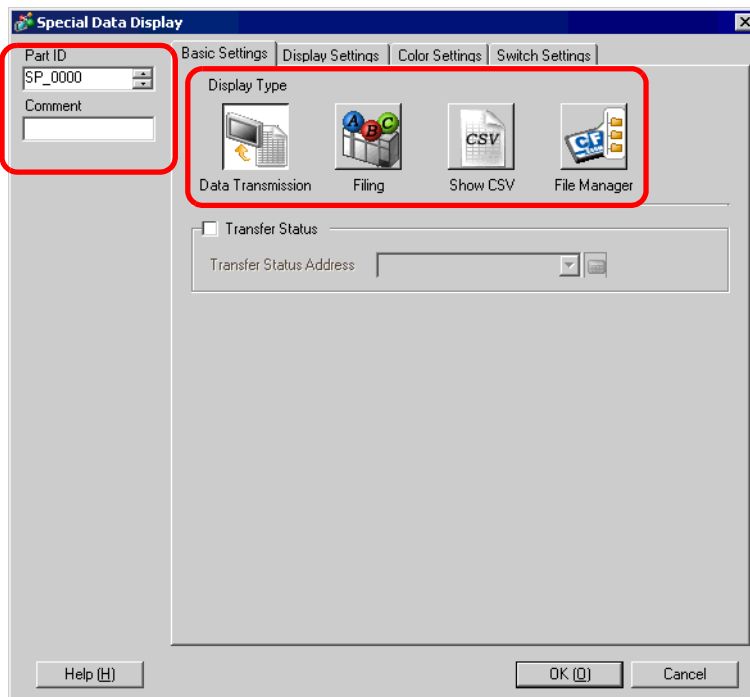

Setting	Description
Part ID	Placed parts are automatically assigned an ID number. Special Data Display's ID: SP_**** (4 digits) The letter portion is fixed. The number portion can be modified from 0000 to 9999.
Comment	The comment for each Part can be up to 20 characters long.
Display Type	<p>Select which Display to place.</p> <ul style="list-style-type: none"> • Data Transmission Display recipe data's (CSV data's) Condition Name in a list on the screen, and transfer the selected recipes between the GP's CF-card and device/PLC. ☞ " ■ Data Transmission" (page 25-72) • Filing Display filing data's Item Name in a list on the screen, and transfer the selected recipes between the GP's backup SRAM and device/PLC. ☞ " ■ Filing Display" (page 25-78) • Show CSV Displays CSV data (Recipe data, Alarm History data, Sampling data, etc.) which is saved on the CF-card on the screen. You can also edit or print the data. The [File Manager] and [Data Transmission] display parts are used together. ☞ " ■ Show CSV" (page 25-81) • File Manager Displays a list of all files and folders saved in the CF-card on the screen. ☞ " ■ File Manager" (page 25-86)

■ **Data Transmission**

Display recipe data's (CSV data's) Condition Name in a list on the screen, and transfer the selected data between the GP's CF-card and device/PLC.

◆ **Basic Settings**

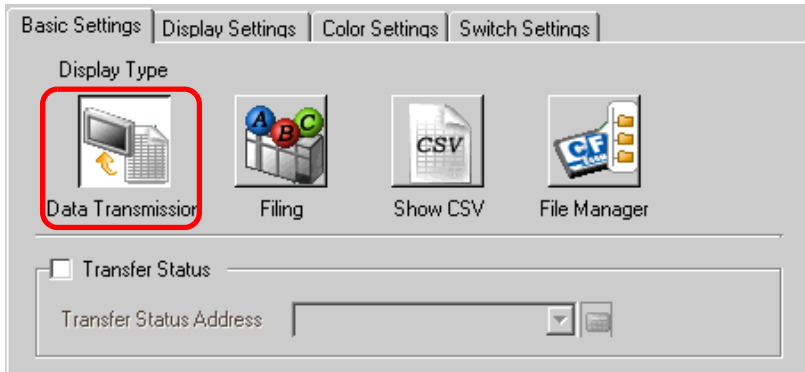

Setting	Description																																															
Transfer Status	Select whether or not to set an address which will verify the status (transfer state and result) when transferring.																																															
Transfer Status Address	Designate the address where the transfer status and result will be stored.																																															
	<div style="text-align: center;"> <table border="1" style="margin: auto;"> <tr> <td style="text-align: center;">15</td> <td style="text-align: center;">12</td> <td style="text-align: center;">11</td> <td style="text-align: center;">2</td> <td style="text-align: center;">1</td> <td style="text-align: center;">0</td> </tr> <tr> <td colspan="3" style="text-align: center;">Reserved (0)</td> <td colspan="3"></td> </tr> <tr> <td colspan="3" style="text-align: center;">Error Status</td> <td colspan="3" style="text-align: center;">Transfer Completed</td> </tr> </table> </div> <p>Error Codes (Results reflected in the error status bits)</p> <table border="1" style="width: 100%; border-collapse: collapse;"> <thead> <tr> <th>Bit</th> <th>Code Name</th> <th>Description</th> </tr> </thead> <tbody> <tr> <td>0</td> <td>Completed Successfully</td> <td>Transfer completed successfully.</td> </tr> <tr> <td>1</td> <td>(Reserved)</td> <td style="text-align: center;">—</td> </tr> <tr> <td>2</td> <td>No Transfer Condition No.</td> <td>For CF-to-PLC or PLC-to-CF transfer, the Condition No. (GROUP NO) corresponding to the specified File No. does not exist.</td> </tr> <tr> <td>3</td> <td>Internal Device Range Error</td> <td>In a CF-card to device/PLC data transfer in which the start address of the transfer is specified to the internal device, data transfer is attempted to an address outside the specified range of the internal device.</td> </tr> <tr> <td>4</td> <td>No CF-Card</td> <td>No CF-card is inserted, or the cover is open.</td> </tr> <tr> <td>5</td> <td>CF Read Error</td> <td>Read-out from the CF-card failed in a CF-to-PLC data transfer.</td> </tr> <tr> <td>6</td> <td>CF Write Error</td> <td>Data writing failed in a PLC-to-CF data transfer, or not enough available space.</td> </tr> <tr> <td>7</td> <td>CF-Card Error</td> <td>CF-card is invalid or the media inserted is not a CF-card.</td> </tr> <tr> <td>8</td> <td>(Reserved)</td> <td style="text-align: center;">—</td> </tr> </tbody> </table> <p style="text-align: right;">Continued on the next page.</p>	15	12	11	2	1	0	Reserved (0)						Error Status			Transfer Completed			Bit	Code Name	Description	0	Completed Successfully	Transfer completed successfully.	1	(Reserved)	—	2	No Transfer Condition No.	For CF-to-PLC or PLC-to-CF transfer, the Condition No. (GROUP NO) corresponding to the specified File No. does not exist.	3	Internal Device Range Error	In a CF-card to device/PLC data transfer in which the start address of the transfer is specified to the internal device, data transfer is attempted to an address outside the specified range of the internal device.	4	No CF-Card	No CF-card is inserted, or the cover is open.	5	CF Read Error	Read-out from the CF-card failed in a CF-to-PLC data transfer.	6	CF Write Error	Data writing failed in a PLC-to-CF data transfer, or not enough available space.	7	CF-Card Error	CF-card is invalid or the media inserted is not a CF-card.	8	(Reserved)
15	12	11	2	1	0																																											
Reserved (0)																																																
Error Status			Transfer Completed																																													
Bit	Code Name	Description																																														
0	Completed Successfully	Transfer completed successfully.																																														
1	(Reserved)	—																																														
2	No Transfer Condition No.	For CF-to-PLC or PLC-to-CF transfer, the Condition No. (GROUP NO) corresponding to the specified File No. does not exist.																																														
3	Internal Device Range Error	In a CF-card to device/PLC data transfer in which the start address of the transfer is specified to the internal device, data transfer is attempted to an address outside the specified range of the internal device.																																														
4	No CF-Card	No CF-card is inserted, or the cover is open.																																														
5	CF Read Error	Read-out from the CF-card failed in a CF-to-PLC data transfer.																																														
6	CF Write Error	Data writing failed in a PLC-to-CF data transfer, or not enough available space.																																														
7	CF-Card Error	CF-card is invalid or the media inserted is not a CF-card.																																														
8	(Reserved)	—																																														

Setting	Description	
Transfer Status Address	7	CF-Card Error CF-card is invalid or the media inserted is not a CF-card.
	8	(Reserved) —
	9	(Reserved) —
	10	(Reserved) —
	11	No Condition Settings In the Condition Settings without the “Enable Data Transmission Feature” settings, a CSV file attempts to display on the CSV display from a CF-card.
	12	Write Error Data writing failed in a CF-to-PLC data transfer.
	13	Read Error Read-out from the PLC failed in a PLC-to-CF data transfer.

Manual Transfer Timing Chart

Touch the transfer switch, and the [Transfer Status Address]’s Transferring bit (bit 0) turns ON. When a data transfer is completed successfully, the Transferring bit turns OFF, and the Transfer Completion bit (bit 1) turns ON. After confirming that the transfer completed, please turn the Transfer Completion Bit Address OFF.

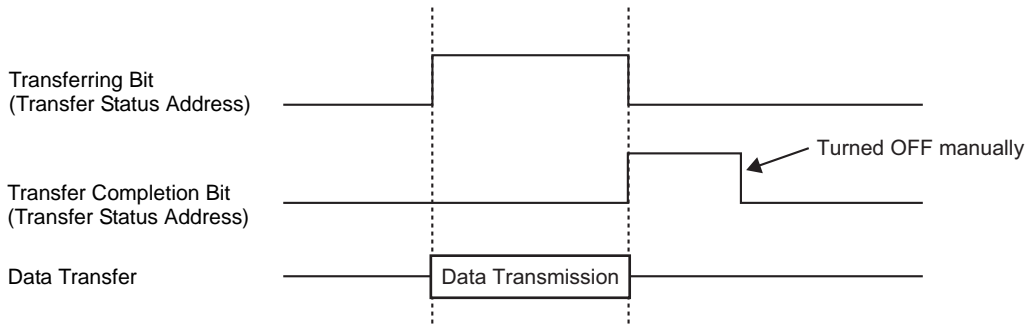

IMPORTANT

- The Transfer Completion Bit (bit 1) will not be turned OFF automatically. Please turn it OFF from the device/PLC.

◆ Display Settings

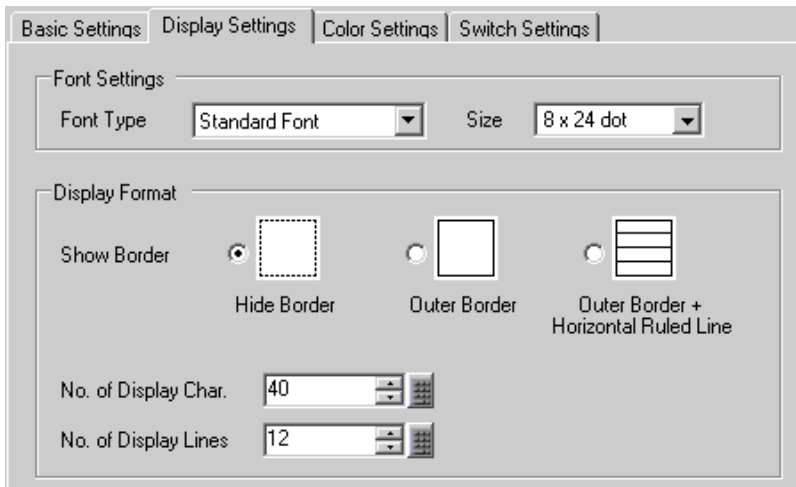

Setting	Description
Font Type	<p>Choose a font type for the characters and numeric values from [Standard Font] or [Stroke Font].</p> <ul style="list-style-type: none"> • Standard Font This is a Bit Map font. Choose the magnification ratio of the characters’ height and width. When you magnify/shrink characters, the outline may become rough or the letter may appear squished. • Stroke Font This is an outline font where the ratio of the characters’ height/width is fixed. The letters will have a smooth outline even if you magnify/shrink them, however, this font has a large size so it can burden the GP.

Continued

Setting	Description
Size	Select a font size for the characters and numeric values to be displayed. Standard Font: From [8 × 8 dot] to [64 × 128 dot], in a ratio of 8 dot units Fixed Size: select from [6 × 10 dot], [8 × 13 dot], or [13 × 23 dot] Stroke Font: 6 to 127 dots
Show Border	Select the type of data border from [Hide Border], [Outer Border], or [Outer Border + Horizontal Ruled Line].
No. of Display Char.	Set the number of characters to be displayed on each line from 1 to 100.
No. of Display Lines	Set the number of lines to be displayed from 1 to 50.

◆ Color Settings

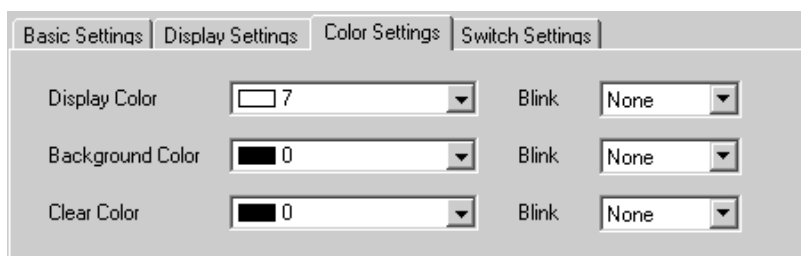

Setting	Description
Display Color	Select a color for the displayed text.
Background Color	Set the Display's background color.
Blink	Select whether or not the Part will blink, and the blink speed. You can choose different blink settings for the [Display Color], and [Background Color]. NOTE <ul style="list-style-type: none"> There are cases where you can and can not set Blink depending on the Main Unit and System Settings' [Color Settings]. "9.5.1 Specify Color ■ Supported Color List" (page 9-33)

◆ **Switch Settings**

Set the switches attached to the Data Transmission Display.

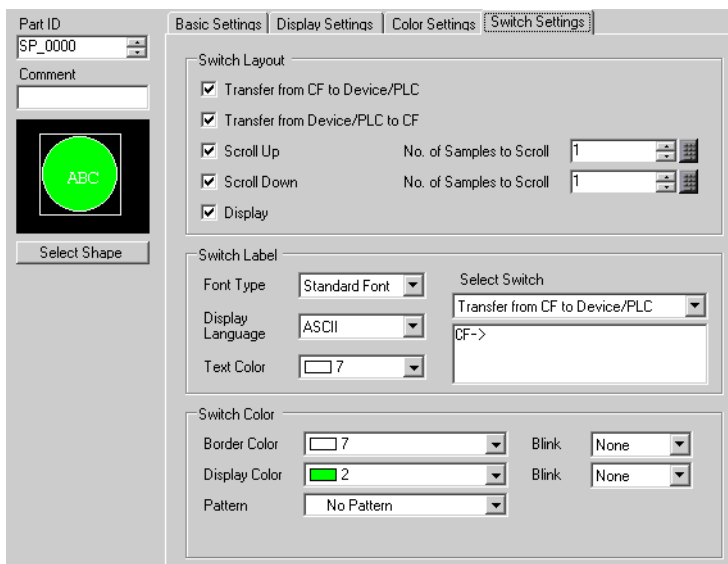

Setting		Description
Part Shape		Displays the shape that you chose for the switch with [Select Shape].
Select Shape		Open the [Select Shape] dialog box to choose the switch's shape.
Switch Layout	Transfer from CF to Device/PLC	Select whether or not to place a switch to transfer CSV data from the CF-card to the PLC.
	Transfer from Device/PLC to CF	Select whether or not to place a switch to transfer CSV data from the device/PLC to the CF-card.
	Scroll Up	Select whether or not to place a switch to scroll the Data Display up. If you touch this switch while CSV data is selected, the selection will be cancelled.
	Scroll Down	Select whether or not to place a switch to scroll the Data Display down. If you touch this switch while CSV data is selected, the selection will be cancelled.
	No. of Samples to Scroll	When the [Scroll Up] and [Scroll Down] switches are placed, designate how many rows they will scroll when pressed. The value can be from 1 to 100.
	Display	Select whether or not to place a switch which will display selected CSV data in the [Show CSV] Display. If you touch this switch when multiple CSV files are selected, the top CSV file will be displayed.

Continued

Setting		Description
Switch Label	Font Type	Choose the label font for the switches from [Standard Font] or [Stroke Font].
	Display Language	Choose the label's display language from [ASCII], [Japanese], [Taiwanese], [Chinese], or [Korean].
	Text Color	Select the font color that will be displayed on the switches' labels.
	Select Switch	All the placed switches will be displayed. From among those, select the Switch whose label you will input into.
	Label	Enter the text that you want to display on the switch selected in [Select Switch].
Switch Color	Border Color	Select a border color for the Switch. NOTE <ul style="list-style-type: none"> Some settings cannot be set depending on the part that you chose with [Select Shape].
	Display Color	Set the switches' color.
	Pattern	Select the switches' pattern from among 9 types.
	Pattern Color	Select the switches' pattern color.
	Blink	Select whether or not the Part will blink, and the blink speed. You can choose different blink settings for the [Display Color], [Pattern Color], [Border Color], and [Text Color]. NOTE <ul style="list-style-type: none"> There are cases where you can and can not set Blink depending on the Main Unit and System Settings' [Color Settings].  "9.5.1 Specify Color ■ Supported Color List" (page 9-33)

■ Filing Display

Display filing data's Item Name in a list on the screen, and transfer the selected data between the GP's backup SRAM and device/PLC.

◆ Basic Settings

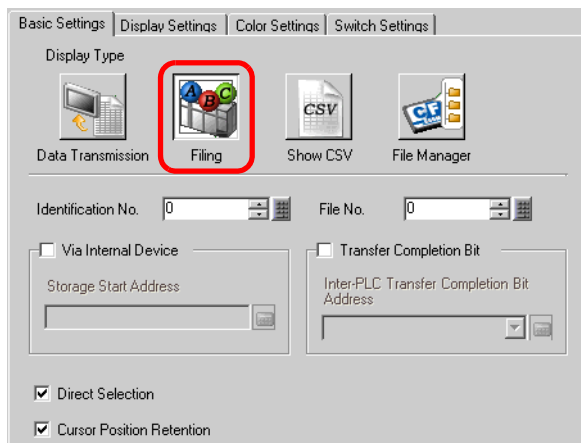

Setting	Description
Identification No.	An ID number related to the [Filing] Display and a Switch Lamp [Special Switch]'s [File Item Switch]. The value can be from 0 to 255. When placing two or more [Filing] Displays on one screen, be sure not to duplicate this ID No.
File No.	Designate the filing data number to display in the [Filing] Display from 0 to 2,047.
Via Internal Device	Designate whether or not to go via the internal device when transferring filing data. By temporarily storing filing data in the internal device, you can use a Data Display to view and edit data on the GP screen. ☞ "25.12.3 Manual Transfer Via the Internal Device" (page 25-111) NOTE <ul style="list-style-type: none"> While filing data is being transferred between SRAM and the internal device, the GP internal device's (Special Relay Area's) LS2032 bit 11 will be turned ON.
Storage Start Address	When [Via Internal Device] is designated, select a start address for data stored there.
Transfer Completion Bit	Designate whether or not to confirm that transfer between SRAM and the device/PLC is complete with a designated bit.
Inter-PLC Transfer Completion Bit Address	Designate the bit address to confirm that transfer is complete. NOTE <ul style="list-style-type: none"> If data transmission cannot be performed, this bit will stay OFF, and the internal device's (Special Relay Area's) LS2032 bit 10 will turn ON.
Direct Selection	When selecting data to transfer, displayed item names can be touched to select them if this is designated. If not designated, the up/down cursor switches must be used to select item names.

Continued

Setting	Description
Cursor Position Retention	Designate whether or not to save the current cursor position when a screen change occurs.

◆ **Display Settings**

Same as for a Special Data Display [Data Transmission].

☞ “25.10.2 Special Data Display Settings Guide ◆ Display Settings” (page 25-74)

◆ **Color Settings**

Same as for a Special Data Display [Data Transmission].

☞ “25.10.2 Special Data Display Settings Guide ◆ Color Settings” (page 25-75)

◆ **Switch Settings**

Set the switches attached to the Filing Display.

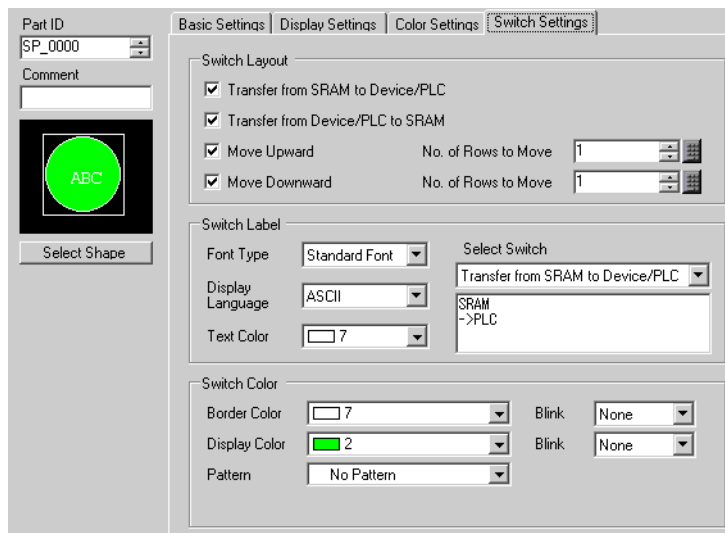

Setting	Description
Part Shape	Displays the shape that you chose for the switch with [Select Shape].
Select Shape	Open the [Select Shape] dialog box to choose the switch’s shape.

Continued

Setting		Description
Switch Layout	Transfer from SRAM to Device/PLC	Select whether or not to place a switch to transfer filing data from backup SRAM to the device/PLC.
	Transfer from Device/PLC to SRAM	Select whether or not to place a switch to transfer filing data from the device/PLC to backup SRAM.
	Move Upward	Select whether or not to place a switch to move the cursor up.
	Move Downward	Select whether or not to place a switch to move the cursor down.
	No. of Rows to Move	When placing an [Move Upward] or [Move Downward] switch, set how many rows it will scroll when pressed. The value can be from 1 to 2,048.
Switch Label	Font Type	Choose the label font for the switches from [Standard Font] or [Stroke Font].
	Display Language	Choose the label's display language from [ASCII], [Japanese], [Taiwanese], [Chinese], or [Korean].
	Text Color	Select the font color that will be displayed on the switches' labels.
	Select Switch	All the placed switches will be displayed. From among those, select the Switch whose label you will input into.
	Label	Enter the text that you want to display on the switch selected in [Select Switch].
Switch Color	Border Color	Select a border color for the Switch. NOTE <ul style="list-style-type: none"> Some settings cannot be set depending on the part that you chose with [Select Shape].
	Display Color	Set the switches' color.
	Pattern	Select the switches' pattern from among 9 types.
	Pattern Color	Select the switches' pattern color.
	Blink	Select whether or not the Part will blink, and the blink speed. You can choose different blink settings for the [Display Color], [Pattern Color], [Border Color], and [Text Color]. NOTE <ul style="list-style-type: none"> There are cases where you can and can not set Blink depending on the Main Unit and System Settings' [Color Settings].  "9.5.1 Specify Color ■ Supported Color List" (page 9-33)

■ Show CSV

Displays CSV data (Recipe data, Alarm History data, Sampling data, etc.) which is saved on the CF-card on the screen. You can also edit or print the data.

The [File Manager] and [Data Transmission] display parts are used together.

◆ Basic Settings

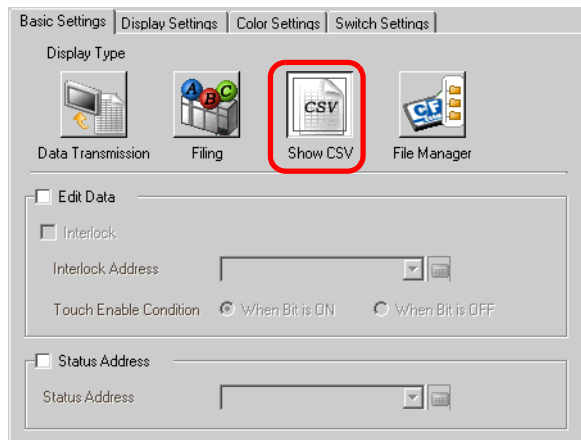

Setting	Description
Edit Data	Select whether or not to edit data in the CSV Display. If selected, touch the cell you want to edit and the editing screen appears.
Interlock	When [Edit Data] is designated, select whether or not to use the Interlock feature (the feature to allow data editing only when a condition is satisfied).
Interlock Address	If the Interlock feature is enabled, designate the address which will control whether touch is enabled or disabled. Only when this bit address is in the same state as the [Touch Enable Condition] can data be edited by touching it.
Touch Enable Condition	When using the Interlock feature, choose the condition which will enable touch. <ul style="list-style-type: none"> • When Bit is ON Touch is only enabled when the designated [Interlock Address] is ON. • When Bit is OFF Touch is only enabled when the designated [Interlock Address] is OFF.
Status Address	When editing or printing data, designate whether or not to confirm the status and error contents with the designated address.

Continued

Setting	Description																											
Status Address	<p>Set the word address to store the current status of data editing and printing.</p> <p style="text-align: center;">Error Codes (Reflected in the error status bits)</p> <table border="1" style="width: 100%; border-collapse: collapse;"> <tr> <td style="text-align: center;">0</td> <td style="text-align: center;">Completed Successfully</td> <td>Transfer completed successfully.</td> </tr> <tr> <td style="text-align: center;">1</td> <td style="text-align: center;">(Reserved)</td> <td style="text-align: center;">—</td> </tr> <tr> <td style="text-align: center;">2</td> <td style="text-align: center;">(Reserved)</td> <td style="text-align: center;">—</td> </tr> <tr> <td style="text-align: center;">3</td> <td style="text-align: center;">(Reserved)</td> <td style="text-align: center;">—</td> </tr> <tr> <td style="text-align: center;">4</td> <td style="text-align: center;">No CF-Card</td> <td>No CF-card is inserted, or the cover is open.</td> </tr> <tr> <td style="text-align: center;">5</td> <td style="text-align: center;">CF Read Error</td> <td>Read-out from the CF-card failed in a CF-to- PLC data transfer.</td> </tr> <tr> <td style="text-align: center;">6</td> <td style="text-align: center;">CF Write Error</td> <td>Data writing failed in a PLC-to-CF data transfer, or not enough available space.</td> </tr> <tr> <td style="text-align: center;">7</td> <td style="text-align: center;">CF-Card Error</td> <td>CF-card is invalid or the media inserted is not a CF-card.</td> </tr> <tr> <td style="text-align: center;">8</td> <td style="text-align: center;">(Reserved)</td> <td style="text-align: center;">—</td> </tr> </table> <ul style="list-style-type: none"> • Edit Data Outputting Bit This setting is turned ON when the “ENT” key is touched after editing CSV data with the editing screen, and it remains ON while the CSV data is read out to the CF-card. While the edited data is being output, that cell’s data cannot be printed or edited. • Printing Bit This bit is turned ON while printing is being executed. While printing, you cannot edit data or execute other print jobs. 	0	Completed Successfully	Transfer completed successfully.	1	(Reserved)	—	2	(Reserved)	—	3	(Reserved)	—	4	No CF-Card	No CF-card is inserted, or the cover is open.	5	CF Read Error	Read-out from the CF-card failed in a CF-to- PLC data transfer.	6	CF Write Error	Data writing failed in a PLC-to-CF data transfer, or not enough available space.	7	CF-Card Error	CF-card is invalid or the media inserted is not a CF-card.	8	(Reserved)	—
	0	Completed Successfully	Transfer completed successfully.																									
	1	(Reserved)	—																									
	2	(Reserved)	—																									
	3	(Reserved)	—																									
	4	No CF-Card	No CF-card is inserted, or the cover is open.																									
	5	CF Read Error	Read-out from the CF-card failed in a CF-to- PLC data transfer.																									
	6	CF Write Error	Data writing failed in a PLC-to-CF data transfer, or not enough available space.																									
	7	CF-Card Error	CF-card is invalid or the media inserted is not a CF-card.																									
	8	(Reserved)	—																									

◆ Display Settings

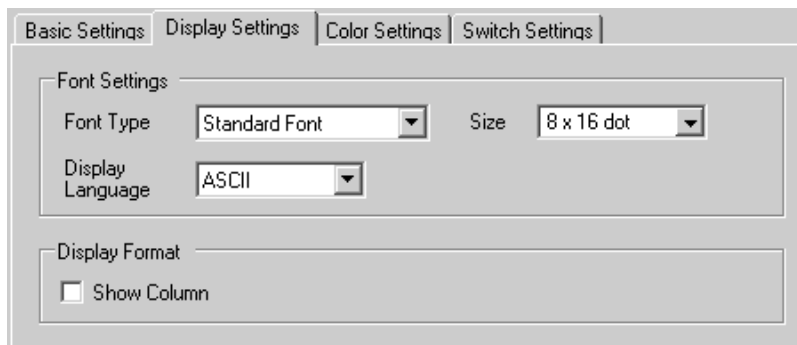

Setting	Description
Font Type	<p>Choose a font type for the CSV data from [Standard Font] or [Stroke Font].</p> <ul style="list-style-type: none"> • Standard Font This is a Bit Map font. Choose the magnification ratio of the characters' height and width. When you magnify/shrink characters, the outline may become rough or the letter may appear squished. • Stroke Font This is an outline font where the ratio of the characters' height/width is fixed. The letters will have a smooth outline even if you magnify/shrink them, however, this font has a large size so it can burden the GP.
Size	<p>Select a font size for the CSV data.</p> <p>Standard Font: From [8 × 8 dot] to [64 × 128 dot], in a ratio of 8 dot units Fixed Size: select from [6 × 10 dot], [8 × 13 dot], or [13 × 23 dot] Stroke Font: 6 to 127 dots</p>
Display Language	<p>Choose the CSV data's language from [ASCII], [Japanese], [Taiwanese], [Chinese], or [Korean].</p>
Show Column	<p>Select whether or not to display the row number and column number in the [Show CSV]. The column portion can not be edited or printed.</p>

◆ Color Settings

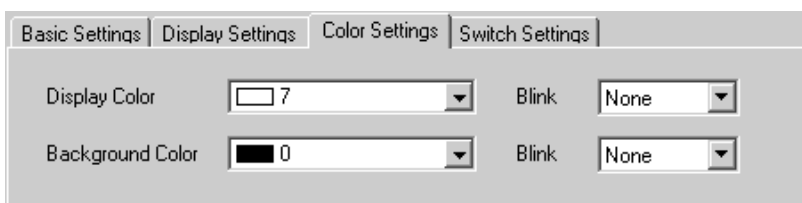

Setting	Description
Display Color	Select a color for the displayed text.
Background Color	Set the Display's background color.

Continued

Setting	Description
Blink	<p>Select whether or not the Part will blink, and the blink speed. You can choose different blink settings for the [Display Color], and [Background Color].</p> <p>NOTE</p> <ul style="list-style-type: none"> There are cases where you can and can not set Blink depending on the Main Unit and System Settings' [Color Settings].  "9.5.1 Specify Color ■ Supported Color List" (page 9-33)

◆ **Switch Settings**

Configure settings for the switches (Scroll switches, Print switch) attached to the CSV Display.

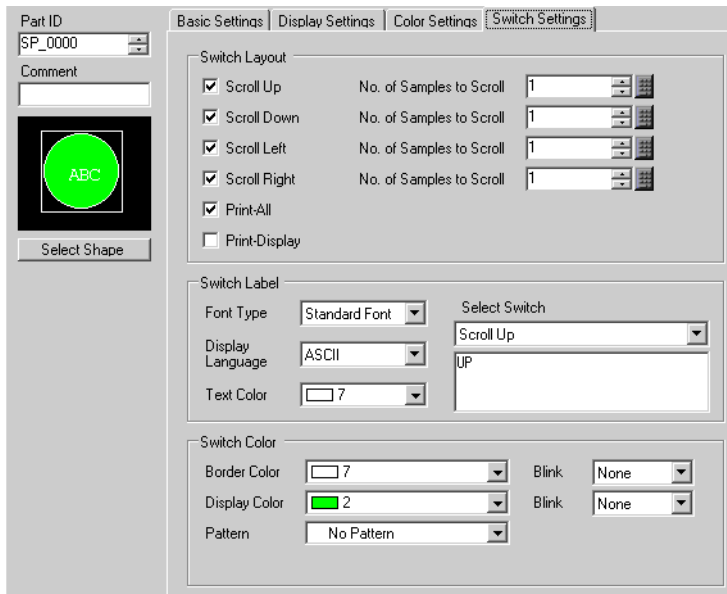

Setting	Description	
Part Shape	Displays the shape that you chose for the switch with [Select Shape].	
Select Shape	Open the [Select Shape] dialog box to choose the switch's shape.	
Switch Layout	Scroll Up/Scroll Down/Scroll Left/Scroll Right	Select whether or not to place switches to scroll the [Show CSV] Display in each direction.
	No. of Samples to Scroll	When selecting a switch to place, set how many rows or columns it will scroll when pressed. The value can be from 1 to 1,000.
	Print-All	Select whether or not to place a switch which will print all CSV data.
	Print-Display	Select whether or not to place a switch which will print the currently displayed CSV data.

Continued

Setting		Description
Switch Label	Font Type	Choose the label font for the switches from [Standard Font] or [Stroke Font].
	Display Language	Choose the label's display language from [ASCII], [Japanese], [Taiwanese], [Chinese], or [Korean].
	Text Color	Select the font color that will be displayed on the switches' labels.
	Select Switch	All the placed switches will be displayed. From among those, select the Switch whose label you will input into.
	Label	Enter the text that you want to display on the switch selected in [Select Switch].
Switch Color	Border Color	Select a border color for the Switch. NOTE • Some settings cannot be set depending on the part that you chose with [Select Shape].
	Display Color	Set the switches' color.
	Pattern	Select the switches' pattern from among 9 types.
	Pattern Color	Select the switches' pattern color.
	Blink	Select whether or not the Part will blink, and the blink speed. You can choose different blink settings for the [Display Color], [Pattern Color], [Border Color], and [Text Color]. NOTE • There are cases where you can and can not set Blink depending on the Main Unit and System Settings' [Color Settings]. ☞ "9.5.1 Specify Color ■ Supported Color List" (page 9-33)

■ **File Manager**

Displays a list of all files and folders saved in the CF-card on the screen.

◆ **Basic Settings**

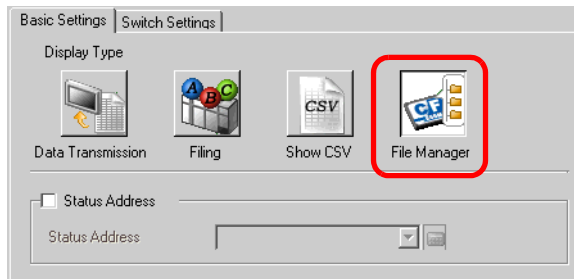

Setting	Description								
Status Address	Designate whether or not to confirm error information with a set address.								
Status Address	Set the word address to store the error information (status).								
	<div style="text-align: center;"> <table border="1" style="margin: auto;"> <tr> <td style="width: 20px; text-align: center;">15</td> <td style="width: 20px; text-align: center;">12</td> <td style="width: 20px; text-align: center;">11</td> <td style="width: 20px; text-align: center;">0</td> </tr> <tr> <td colspan="3" style="border: 1px solid black;"></td> <td style="border: 1px solid black; text-align: center;">Reserved (0)</td> </tr> </table> <p style="margin-left: 40px;">└─ Error Status</p> </div>	15	12	11	0				Reserved (0)
	15	12	11	0					
				Reserved (0)					
	Error Codes (Reflected in the error status bits)								
	0	Completed Successfully Transfer completed successfully.							
	1	(Reserved) —							
	2	(Reserved) —							
	3	(Reserved) —							
	4	No CF-Card No CF-card is inserted, or the cover is open.							
5	CF Read Error Read-out from the CF-card failed in a CF-to- PLC data transfer.								
6	(Reserved) —								
7	CF-Card Error CF-card is invalid, is not initialized, or the media inserted is not a CF-card.								
8	CF-Card Erasure Error File deletion has failed.								

NOTE • To display an image (JPEG file) in a CF-card, you should place and set the picture display as well as the file manager.
 ☞ “ ■ CF Image Display” (page 10-44)

◆ **Switch Settings**

Configure the parameters for the Display switch used to call up the [File Manager] Display from a base screen.

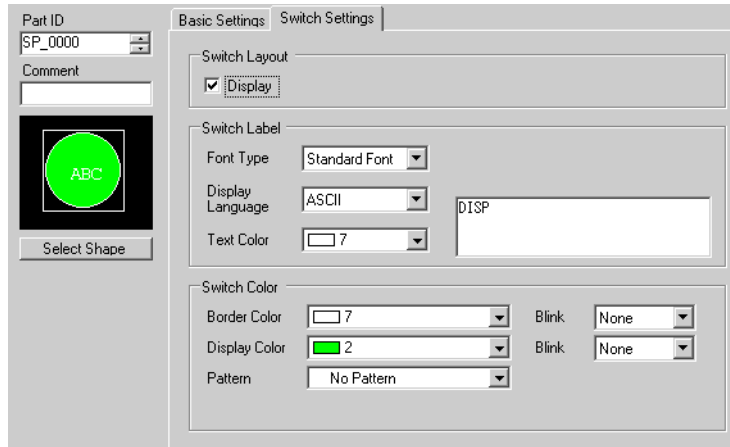

Setting		Description
Part Shape		Displays the shape that you chose for the switch with [Select Shape].
Select Shape		Open the [Select Shape] dialog box to choose the switch's shape.
Switch Layout	Display	Designate whether or not to place a switch to display a [File Manager] Display on the base screen.
Switch Label	Font Type	Choose the label font for the switches from [Standard Font] or [Stroke Font].
	Display Language	Choose the label's display language from [ASCII], [Japanese], [Taiwanese], [Chinese], or [Korean].
	Text Color	Select the font color that will be displayed on the switches' labels.
	Label	Input the text to display on the Switch.
Switch Color	Border Color	Select a border color for the Switch. NOTE • Some settings cannot be set depending on the part that you chose with [Select Shape].
	Display Color	Set the switches' color.
	Pattern	Select the switches' pattern from among 9 types.
	Pattern Color	Select the switches' pattern color.
	Blink	Select whether or not the Part will blink, and the blink speed. You can choose different blink settings for the [Display Color], [Pattern Color], [Border Color], and [Text Color]. NOTE • There are cases where you can and can not set Blink depending on the Main Unit and System Settings' [Color Settings]. ☞ "9.5.1 Specify Color ■ Supported Color List" (page 9-33)

25.11 Transfer CSV Data Setup

25.11.1 Transfer CSV Data Setup

The Destination Address and other information is not included in created CSV data. Set the condition necessary for transfer (Destination Address, No. of Data, etc.) separate from the data.

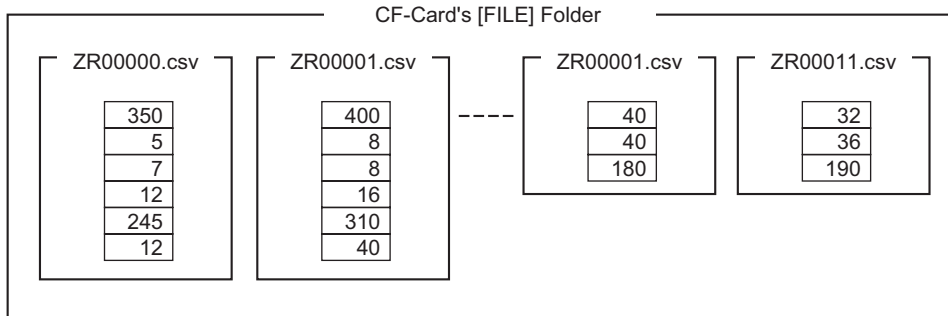

Condition Settings Example

Collected files to be transferred to the same address are set as a single condition (GROUP). In the file name [ZR****.csv], **** represents the file number portion.

Condition No.	Condition Name	Address	No. of Data	File No.
0	Material 1	D100 -	6	0 - 9
1	Temp.	D110 -	3	10 - 19
2	Material 2	D300 -	50	20 - 99

This is the top address of the transfer destination (or source). The device/PLC's or internal device's address can be set.

Designate the range (the start number to the termination number) of the files you want to transfer with the same condition.



Transfer the CSV data from “ZR00000.csv” and “ZR00010.csv” to the device/PLC, and “ZR00000.csv” will be written according to Condition No. 0, and “ZR00010.csv” will be written according to Condition No. 1.

6 words are stored starting from address D100

3 words are stored starting from address D110

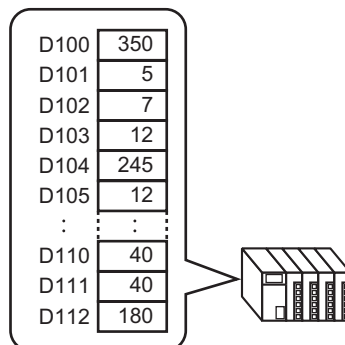

NOTE

- If the number of data items designated in the condition settings differs from that of the recipes (CSV data), the smaller number of data items will be transferred.
- Please ensure that the file numbers set in the condition settings ([Start No.] to [Termination No.]) are not repeated in multiple conditions. If file numbers are repeated in several conditions, data will be transferred according to the condition with the smaller number.

Condition No.	Condition Name		File No.
0	Product A		0 - 3
1	Product B		2 - 5

The overlapping files ZR00002.CSV and ZR00003.CSV are transferred according to Condition No. 0.

- Without using preset condition settings, you can set the condition (Destination Address, No. of Data, etc.) at the time of transfer.
 "25.11.2 Control Word Address ◆ For Address Action" (page 25-93)

25.11.2 Control Word Address

This address controls the transfer when automatically transferring CSV data. The address' contents are different when you transfer with the [Condition Action] or with the [Address Action].

◆ For Condition Action

Designate the number of files to transfer and the file numbers. When the [Control Word Address]'s bit 0 turns ON, CSV data from the CF-card will be written to the device/PLC. When bit 1 turns ON again, device/PLC data is saved to the CF-card according to the [Condition Settings].

A maximum of 64 files can be transferred simultaneously.

Control Word Address	Control
+1	Status
+2	No. of Files (n)
+3	File No. 1
+4	File No. 2
+5	
+2+n	File No. n

- Control
Data is transferred depending on the state of this address' bit 0 to bit 2.

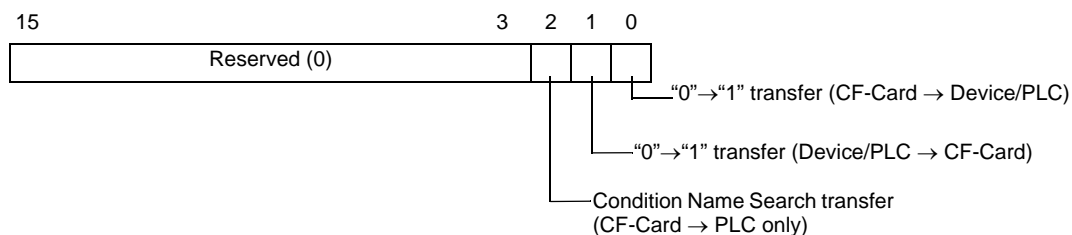

NOTE

- Please ensure that all bits in this address are set to "0" when the GP unit is turned on.
- Please do not turn multiple bits ON at the same time.
- The Condition Name Search transfer can only be run when using the [Condition Name Search Feature].
☞ "25.11.3 Condition Name Search Feature" (page 25-98)

- **Status**

Transfer state and result is reflected in this address.

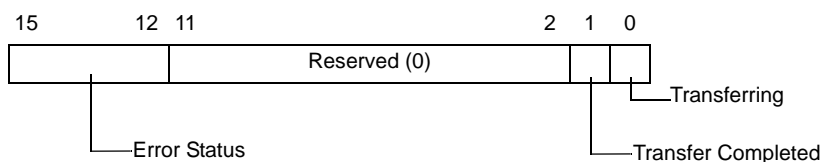

Error Codes (Reflected in the error status bits)

0	Completed Successfully	Transfer completed successfully.
1	No File No.	During transfer of data from CF-card to PLC, target file to be transferred does not exist.
2	No Transfer Condition No.	For CF-to-PLC or PLC-to-CF transfer, the Condition No. (GROUP NO) corresponding to the specified File No. does not exist.
3	Internal Device Range Error	In a CF-to-PLC data transfer in which the start address of the transfer is specified to the internal device, data transfer is attempted to an address outside the specified range of the internal device.
4	No CF-Card	No CF-card is inserted, or the cover is open.
5	CF Read Error	Read-out from the CF-card failed in a CF-to-PLC data transfer.
6	CF Write Error	Data writing failed in a PLC-to-CF data transfer, or not enough available space.
7	CF-Card Error	CF-card is invalid, is not initialized, or the media inserted is not a CF-card.
8	(Reserved)	—
9	No Retrieve Text	No CSV file matches the retrieve text.
10	Index File Error	The index file format is incorrect.

- **No. of Files**

Specify the number of CSV files to be transferred (from 1 to 64).

If this value is “0”, no data will transfer even when the [Control Word Address] turns ON.

Also, status will not restart.

- **File No. 1**

Stores the first File No. to be transferred.

After that, the desired transfer order is stored by file number.

Automatic Transfer (Condition Action) Timing Chart

When the control address' bit 0 (or bit 1) turns ON, the Transferring bit (status bit 0) turns ON. When a data transfer is completed successfully, the Transferring bit turns OFF, and the Transfer Completion Bit (status bit 1) turns ON.

When the data transfer is completed, determine the Transfer Completion Bit via the device/ PLC and turn OFF the Control Address' bit.

Turning OFF the Control Address' bit automatically turns OFF bit 1 (transfer-completed) on the status address.

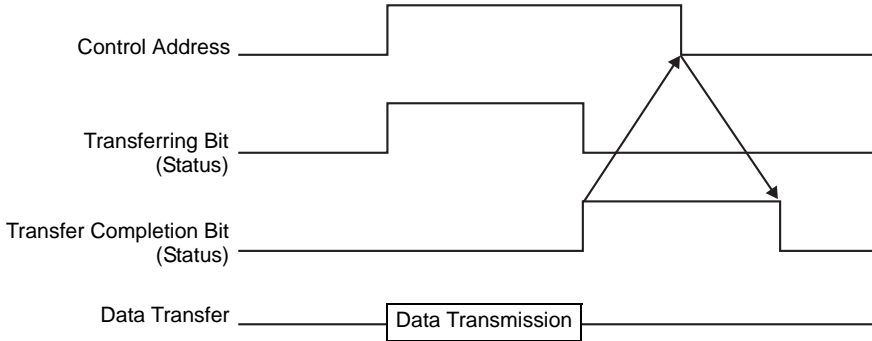

If the transfer fails, the Transferring Bit turns OFF, and the error code is set in the error status (status bits 12-15). Before starting the next transfer, clear the Status and Control bits to 0 and turn on the required Control bit.

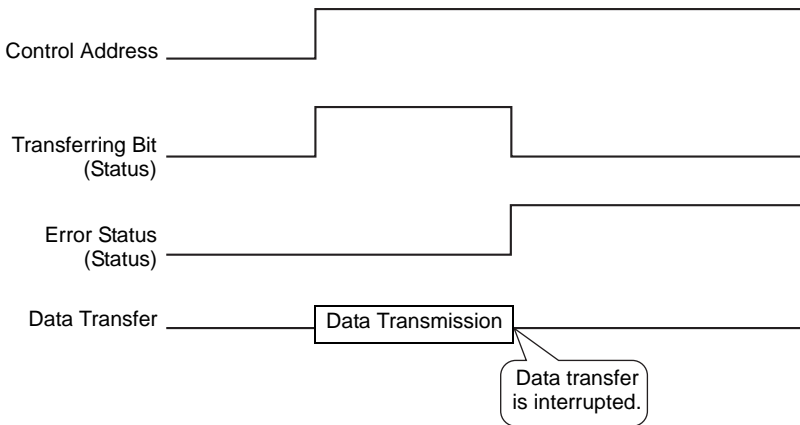

◆ **For Address Action**

By designating the device code and address code*1, the transfer address (or source address) for each file (CSV data) is designated.

Only one file (1 set of CSV data) can be transferred at a time.

The [Control Word Address] uses 16 consecutive words and designates the data to be transferred and the destination address.

NOTE • Even when the control address is 32 bit, the address uses 16 words.

Control Word Address	Control
+1	Status
+2	File No.
+3	Mode
+4	Device Code
+5	•
+6	Address Code
+7	(4 words)
+8	No. of Data
+9	Reserved Area (7 words)
+10	
+11	
+12	
+13	
+14	
+15	

After setting the file number, mode, device code, address code, and number of data, when the [Control Word Address]’s bit 0 turns ON, the designated file number’s Recipe (CSV data) will be written to the specified address.

Also, when the [Control Word Address]’s bit 1 turns ON, data (Recipe) stored in the device/PLC’s designated address is saved to the CF-card.

• Control

Data is transferred depending on the state of this address’ 0 and 1 bits.

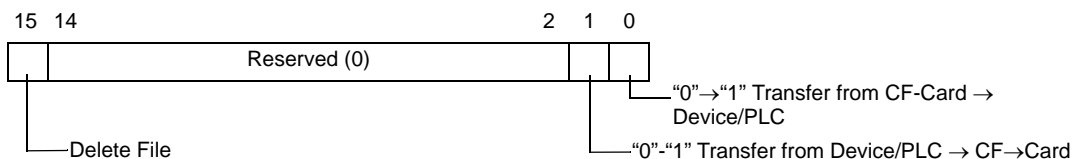

NOTE • Please ensure that all bits in this address are set to “0” when the GP unit is turned on.
• Please do not turn multiple bits ON at the same time.

*1 The device code and address code depend on the designated device/PLC. Please refer to the “GP-Pro EX Device/PLC Connection Manual” for setting information about your device/PLC.

- Status

Transfer state and result is reflected in this address.

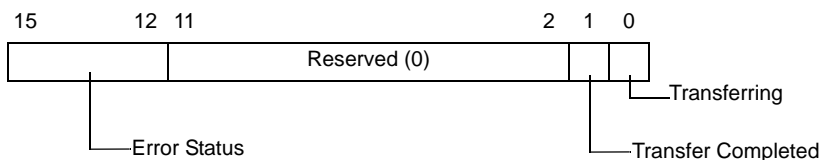

Error Codes (Reflected in the error status bits)

0	Completed Successfully	Transfer completed successfully.
1	No File No.	During transfer of data from CF-card to PLC, target file to be transferred does not exist.
2	(Reserved)	—
3	Internal Device Range Error	In a CF-to-PLC data transfer in which the start address of the transfer is specified to the internal device, data transfer is attempted to an address outside the specified range of the internal device.
4	No CF-Card	No CF-card is inserted, or the cover is open.
5	CF Read Error	Read-out from the CF-card failed in a CF-to-PLC data transfer.
6	CF Write Error	Data writing failed in a PLC-to-CF data transfer, or not enough available space.
7	CF-Card Error	CF-card is invalid, is not initialized, or the media inserted is not a CF-card.
8	CF-Card Erasure Error	Erasure of CF-card failed.
9	(Reserved)	—
10	(Reserved)	—

- File No.

Specify the file number to be transferred.

- Mode

Designate the Recipe's data format and whether negative numbers will be allowed.

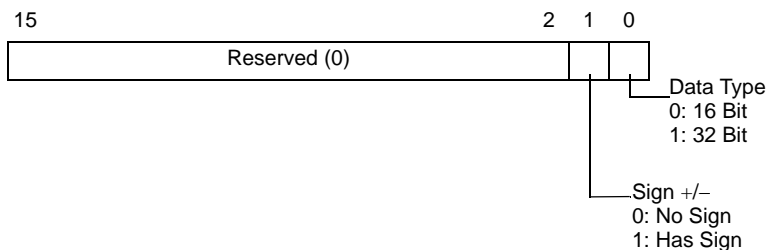

- Device code and address code

Designate the device code to select which device in the device/PLC to access. Also, designate the destination (or source) in the address code.

The device code/address code differ depending on the device/PLC. Please refer to the "GP-Pro EX Device/PLC Connection Manual".

- **No. of Data**
Designate the number of data items in the Recipe (CSV data). The maximum number of data items is 10,000 for 16 bit and 5,000 for 32 bit. If the number of the data items exceeds 10,000, the operation will not be executed.

Automatic Transfer (Address Action) Timing Chart

When the data transfer is completed, status bit 1 (Transfer Completion Bit) turns ON. Please turn OFF the trigger bit after the Transfer Completion Bit is displayed via the device/PLC. Turning OFF the trigger bit automatically turns OFF (Transfer Completion Bit) on the status address.

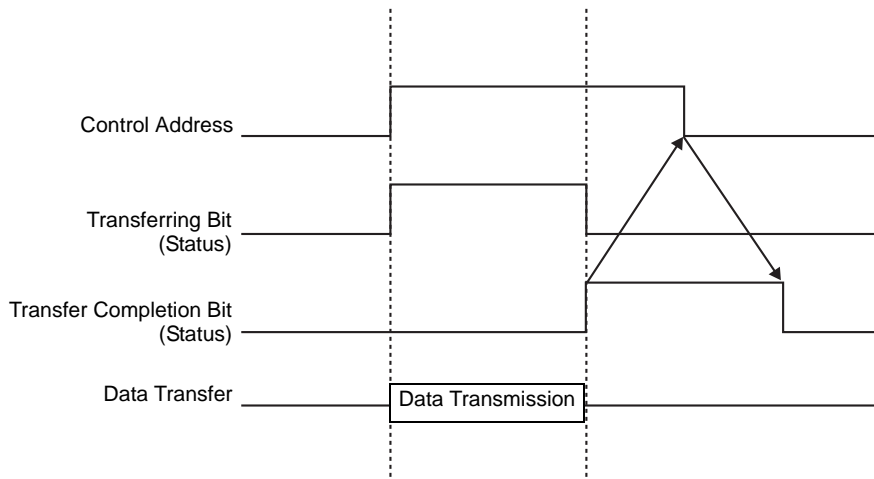

◆ Address Action Transfer Example

Writing from the CF-Card→Device/PLC

e.g.) Transferring “ZR00001.csv” (No. of Data: 6, Data length: 16 Bit, No Sign) from the CF-card to the device/PLC address D100.
Control Word Address: D50

D50	Control
D51	Status
D52	File No.
D53	Mode
D54	Device Code & Address Code (4 words)
D55	
D56	
D57	
D58	No. of Data
D59	• Reserved Area (7 words)
D60	
D61	
D62	
D63	
D64	
D65	

- 1 Write the transfer file’s number “1” to D52.
- 2 Write “0” (16 Bit, No Sign) to D53.
- 3 Write “0” to D54.

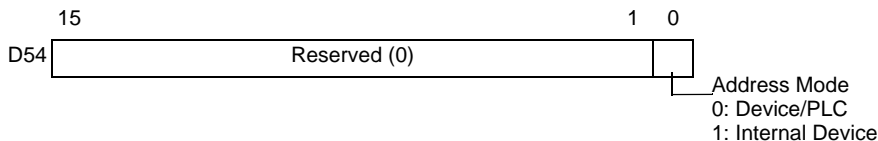

NOTE

- When the transfer destination is the internal device, write “1”.
- For memory link type, please set “0”.

- 4 Write the transfer destination device “0x0000” (D device) to D55.
- 5 Designate the transfer destination address in D56/D57. Write “100” to D56 and “0” to D57.
- 6 Write “6” to D58.
- 7 Turn ON D50’s bit 0. CSV data is written to addresses D100 to D105.
- 8 When the data transfer is completed, turn OFF bit 0 of D51(the [Transferring] bit), and turn ON the [Transfer Completion Bit] (bit 1).

◆ Reading from the Device/PLC→CF-card

e.g.) Transfer six data items (Data Length: 16 Bit, No Sign) from the device/PLC, D100 to D105, to the CF-card and create the file ZR00002.csv.

- 1 Write the file number “2” to be created by transfer to D52.
- 2 Write “0” (16 Bit, No Sign) to D53.
- 3 Write “0” to D54.
- 4 Write the transfer source device “0x0000” (D device) to D55.
- 5 Designate the transfer source address in D56/D57. Write “100” to D56 and “0” to D57.
- 6 Write “6” to D58.
- 7 Turn ON D50’s bit 1. The data from D100 to D105 are read and the file name “ZR00002.csv” is created in the CF-card’s [file] folder.
When the data transfer is completed, turn OFF bit 0 of D51(the [Transferring] bit), and turn ON the [Transfer Completion Bit] (bit 1).

NOTE	• Transfer from device/PLC→CF-card, and the CSV data’s date will be outputted in 2-digit format.
-------------	--

Delete File

e.g.) Delete file name “ZR00002.csv” from the CF-card.

- 1 Write the file number “2” to delete to D52.
- 2 Turn ON D50’s bit 15 (Deletion bit).
When the file deletion is completed, D51’s bit 1 (Transfer Completion Bit) turns ON.

25.11.3 Condition Name Search Feature

When automatically transferring from CF-card to device/PLC, by designating the condition name of the file you want to transfer, you can search for a matching CSV file within the CF-card's [FILE] folder and transfer that data to the device/PLC.

In the following picture, the CSV files that match the product number (condition name) read from the barcode reader are transferred to the device/PLC.

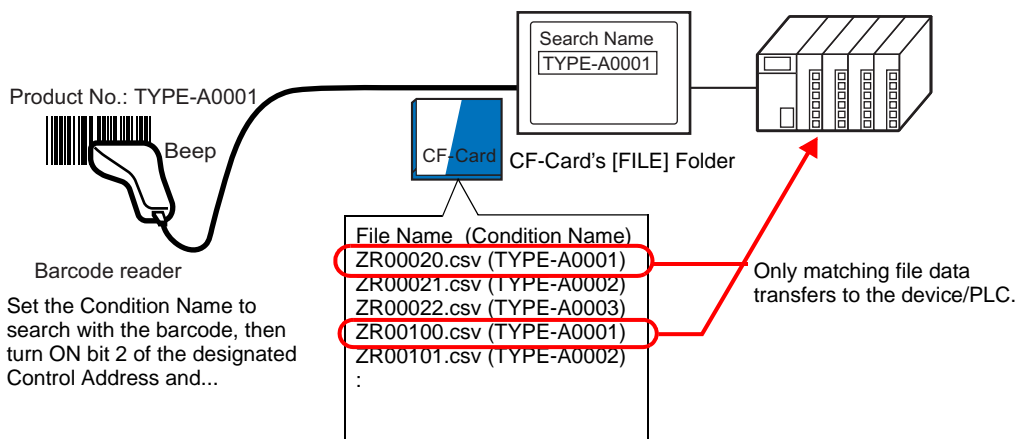

- NOTE**
- The search will only detect files whose condition name is a perfect match for the search string. Please be careful about errors caused by spaces.

The designated [Search Word Address] uses 16 words, and the condition name to be searched can be up to 32 characters. After storing the search condition name, turn ON bit 2 of the [Control Word Address] and the file's search and transfer to the device/PLC will begin. If there are multiple matching files, the CSV data will be transferred in order of file number.

- ☞ “◆ Control Word Address when using the Condition Name Search Feature” (page 25-100)
- ☞ “◆ Condition Name Search Storing Methods” (page 25-102)

If an index file (ZRINDEX.CSV) exists in the CF-card's [FILE] folder, the search will automatically search the contents of the index file.

If there is no index file, in order to reference and search the condition names of all CSV file in the [FILE] folder, the search may take a long time if there are a lot of files. (For example, if approximately 1,000 CSV files are searched, the search operation alone will take about one minute.)

- IMPORTANT**
- Even if the target file exists in the CF-card's [FILE] folder, files whose condition name is not reflected in the index file can not be detected. In that case either update or delete the index file and then transfer the files.

◆ What is the Index File?

After creating CSV data in GP-Pro EX, an index file (ZRINDEX.csv) will be automatically created in the [FILE] folder.

When using the Condition Name Search feature, this file is used to speed up the search. Information (File No. and Condition Name) about recipes (CSV data) registered in GP-Pro EX is written in this file.

The index file has the following format:

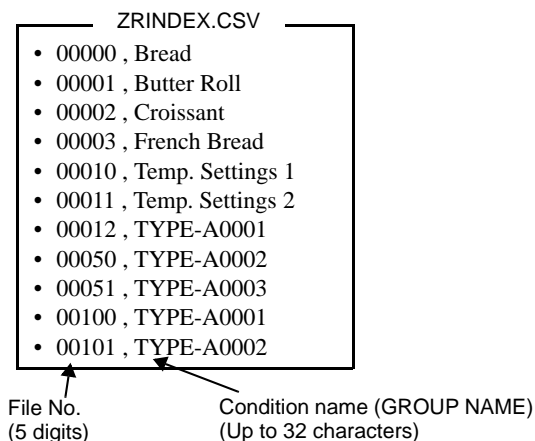

The contents of the index file are automatically updated only when a CSV file is added/edited/deleted in GP-Pro EX's [Recipe Settings] - [Transfer CSV Data (CSV File List)]. If a CSV file has been created in Excel or by a device/PLC to CF-card transfer, the index file will not reflect information for those files. Either open the index file and input the information directly in the file, or add/edit files in GP-Pro EX and then update the index file.

NOTE

- When editing the index file, please ensure not to not to create any index file errors.
In the following cases an index file error will occur and a transfer using the Condition Name Search feature will fail. In such cases, create a new index file or delete the existing index file before resuming the transfer operation. The index file can be deleted by using a Special Data Display [File Manager].
 - (1) A file number is missing.
 - (2) The file number is not within the range of 0 to 65,535.
 - (3) The index file is not in CSV file format.
- The index file's condition names and file numbers are created by referencing all the saved files in the [FILE] folder. It is not created on the basis of GP-Pro EX's condition settings.

◆ **Control Word Address when using the Condition Name Search Feature**

After storing the Condition Name to search, by turning the [Control Word Address]’s transfer bit (bit 2) from OFF to ON, it will be possible to search for CSV files within the CF-card and transfer all CSV files that match the search condition name.

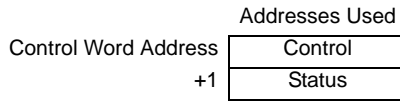

• **Control**

When bit 2 turns ON, search for the file with the condition name which matches the text string designated in [Search Word Address], and write the matching file’s CSV data to the PLC.

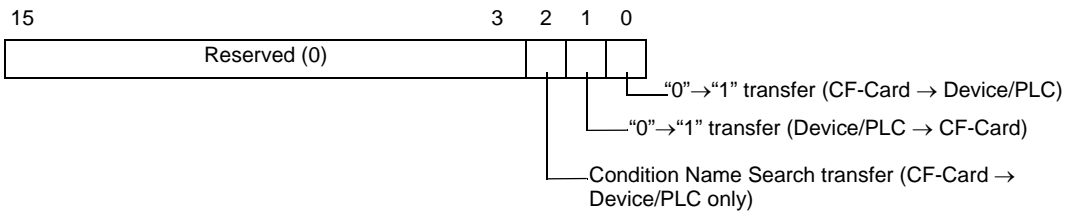

NOTE

- Please ensure that all bits in this address are set to “0” when the GP unit is turned on.
- When bit 0 (CF-card → PLC) and bit 2 (Condition Name Search transfer) turn ON at the same time, neither operation is performed. Please turn ON only bit 2.

• **Status**

Transfer state and result is reflected in this address.

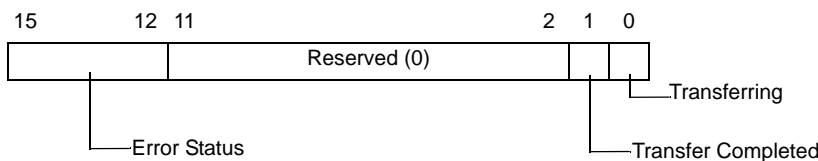

Error Codes (Reflected in the error status bits)

0	Completed Successfully	Transfer completed successfully.
1	No File No.	During transfer of data from CF-card to PLC, target file to be transferred does not exist.
2	No Transfer Condition No.	For CF-to-PLC or PLC-to-CF transfer, the Condition No. (GROUP NO) corresponding to the specified File No. does not exist.
3	Internal Device Range Error	In a CF-to-PLC data transfer in which the start address of the transfer is specified to the internal device, data transfer is attempted to an address outside the specified range of the internal device.
4	No CF-Card	No CF-card is inserted, or the cover is open.
5	CF Read Error	Read-out from the CF-card failed in a CF-to-PLC data transfer.

Continued

6	CF Write Error	Data writing failed in a PLC-to-CF data transfer, or not enough available space.
7	CF-Card Error	CF-card is invalid, is not initialized, or the media inserted is not a CF-card.
8	(Reserved)	–
9	No Retrieve Text	No CSV file matches the retrieve text.
10	Index File Error	The index file's CSV format is incorrect.

Condition Name Search Transfer's Timing Chart

When the control address' bit 2 turns ON, the [Transferring] bit (status bit 0) turns ON. When a data transfer is completed successfully, the [Transferring] bit turns OFF, and the [Transfer Completion Bit] (status bit 1) turns ON. When the data transfer is completed, determine the Transfer Completion Bit via the device/ PLC and turn OFF the Control Address' bit. When the trigger is OFF, the [Transfer Completion] bit will automatically turn OFF.

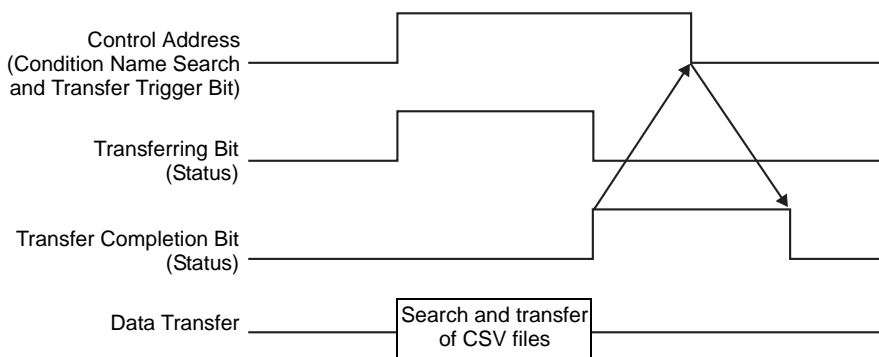

If the transfer fails, the [Transferring Bit] turns OFF, and the error code is set in the error status (status bits 12-15). Before starting the next transfer, clear the Status and Control bits to 0 and turn on the required Control bit.

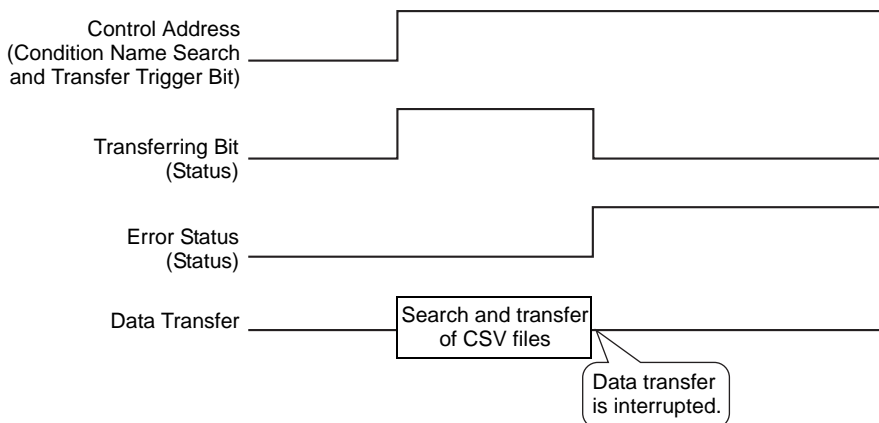

- NOTE**
- The period during which the Transferring Status Bit is ON includes the time required for the search of the CSV files. Therefore, do not access the [FILE] folder in the CF-card while the Transferring Bit is on.

◆ Condition Name Search Storing Methods

In the lower 16 words of the designated [Search Word Address], you can store the condition name according to the Text Data Mode. This can be set to either a device/PLC address or GP internal device address.

If the specified name is less than 32 characters, write 0 (NULL="00(h)") or a blank space in the address following the last character. Characters before the address containing 0 (NULL="00(h)") are considered as the condition name for the search.

Condition Name Search can be performed only for Data Modes 1, 2, 4 or 5. The following are examples of the Text Data Modes.

e.g.) Searching for Condition Name "TYPE-A0001"

- Text Data Mode 1

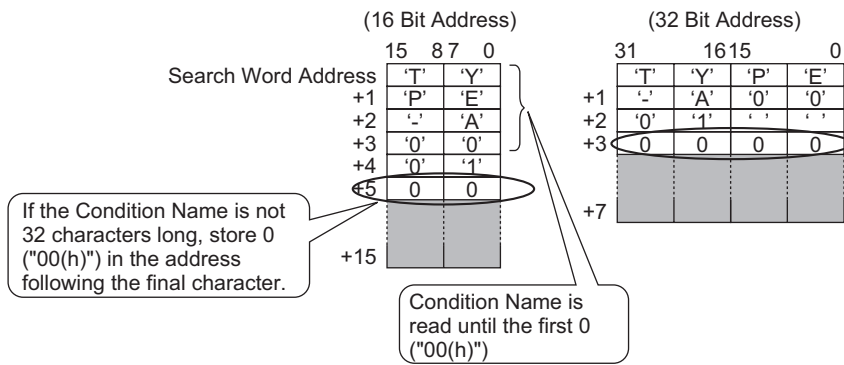

- Text Data Mode 2

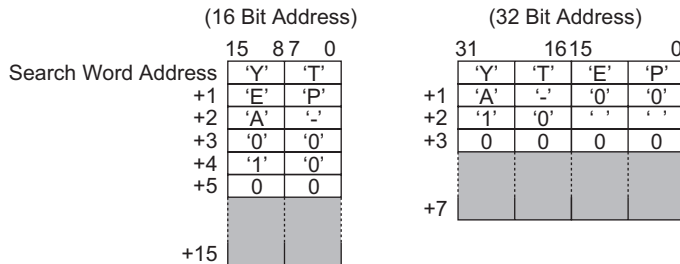

- Text Data Mode 4

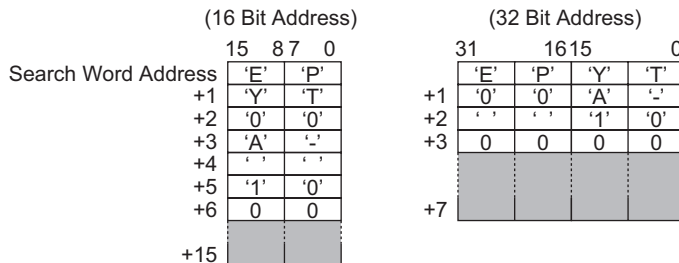

- String Data Mode 5

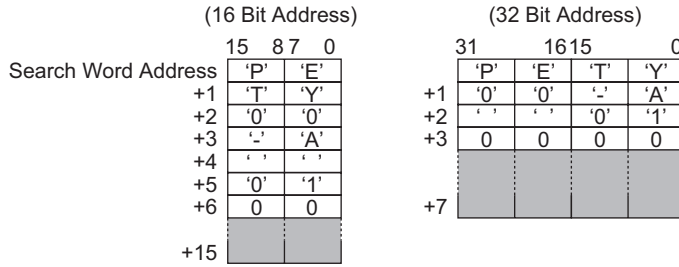

IMPORTANT

- You can use a space in the condition name to search, but it can not appear in the last position. Spaces between the last character and 0 are replaced with 0 in the matching operation.
- If the [Search Word Address]'s top position is 0, the search will look for a file without a condition name.

25.11.4 Automatic Numbering

When using automatic transfer from device/PLC to CF-card, you can automatically allot the file numbers and create new CSV files. This function can be set in the [CSV Data Transfer Condition Settings] dialog box's extended settings.

The automatic numbering action is as follows:

- The new file name is created by adding +1 to the file number with the most recent time stamp among existing files.
- If no free space is left, the file with the oldest time stamp is deleted and a new file is created by adding +1 to the last saved file number.

ZR00000.CSV	9:00
ZR00001.CSV	10:00
ZR00002.CSV	11:00



ZR00001.CSV	10:00
ZR00002.CSV	11:00
ZR00003.CSV	12:00

If files numbered from "ZR00000.CSV" to "ZR00002.CSV" exist, "ZR00000.CSV" is deleted to create "ZR00003.CSV".

- If the file numbers of existing files are not contiguous, a new file is created by adding +1 to the most recent file number.

ZR00000.CSV	9:00
ZR00001.CSV	10:00
ZR00003.CSV	11:00



ZR00000.CSV	9:00
ZR00001.CSV	10:00
ZR00003.CSV	11:00
ZR00004.CSV	12:00

If the file "ZR00002.CSV" does not exist and "ZR00003.CSV" is the most recent, a new file is created as File No. "ZR00004.CSV".

NOTE

- If the file numbers do not conform to time stamps in automatic numbering mode (when files are overwritten by manual transfer), a new file is created by increasing the most recent File No. by +1.

ZR00000.CSV	10:00
ZR00001.CSV	12:00
ZR00002.CSV	11:00
ZR00003.CSV	9:00



ZR00000.CSV	10:00
ZR00001.CSV	12:00
ZR00002.CSV	13:00
ZR00003.CSV	9:00

When files from "ZR00000.CSV" to "ZR00003.CSV" exist, "ZR00002.CSV" is overwritten with the new file.

- When using automatic numbering, please do not allot file numbers in the middle using manual transfer (Device/PLC to CF-card). The files will be overwritten. Regardless of the timestamp update from manual transfer, files will be overwritten in order of the last automatic numbered file number +1. When files are created until the [Termination No.] is reached, even when the [Control Word Address] turns ON after that, data will not be transferred. To continue transferring data, use the [Loop] feature or set the [Resume Bit Address].

- When Using the Loop Feature

When you enable the [Loop] feature, after the [Termination No.] is reached, data will be automatically overwritten starting from the [Start No.] and the transfer will continue.

e.g.) When the Condition Settings are: [Start No.] = 0, [Termination No.] = 4

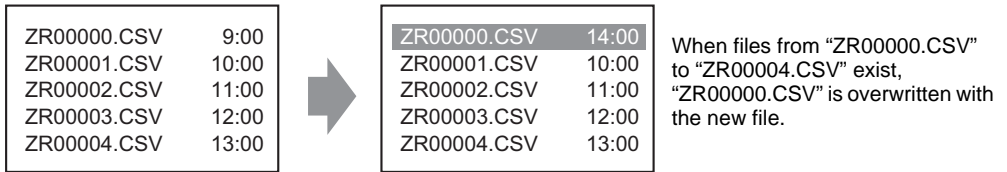

- When using a Resume Bit Address

When the [Termination No.] is reached, if the designated [Resume Bit Address] turns ON, the next time the [Control Word Address] turns ON, the [Start No.] file gets overwritten, and then the other files in order after that are overwritten and transferred.

Automatic Numbering Timing Chart

When you create files from [Start No.] to [Termination No.], the [Full Bit Address] turns ON and automatic transfer ends.

To run automatic transfer again, turn ON the [Resume Bit Address], then turn ON bit 1 of the [Control Word Address]. Files will be overwritten and created in order starting from the [Start No.].

When the [Resume Bit Address] turns ON, the [Full Bit Address] will automatically be turned OFF. Check that the [Full Bit Address] is turned OFF and turn OFF the [Resume Bit Address].

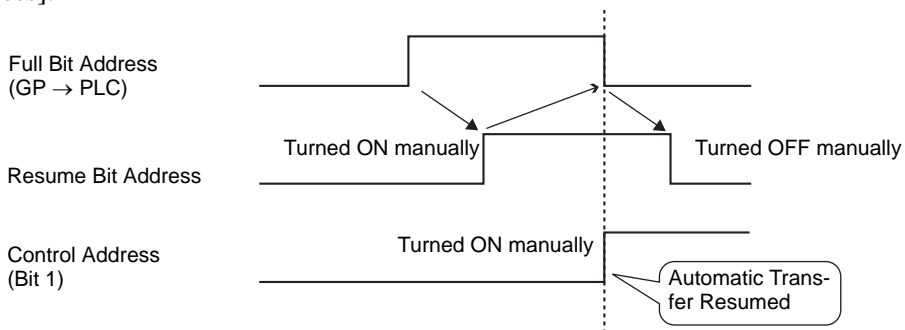

NOTE

- If the CF-card is already full at the time the GP is turned ON, the [Full Bit Address] will turn ON immediately after the [Control Word Address]'s bit 1 turns ON, and the transfer will not execute. In that case, if the [Resume Bit Address] is ON, when the [Control Word Address]'s bit 1 turns ON, the [Start No.] file is overwritten.

Please verify the status of the [Resume Bit Address] and file numbers saved in the CF-card before transferring.

25.12 Transfer Filing Data Setup

25.12.1 Filing Data Structure

Filing data is organized into folders.

One folder can hold a maximum of 2,048 files.

One file can handle a maximum of 1,650 blocks (recipes). Data transfer is carried out in blocks. Also, the maximum number of data items in 1 file is 10,000 (or 5,000 when the data is 32 bit).

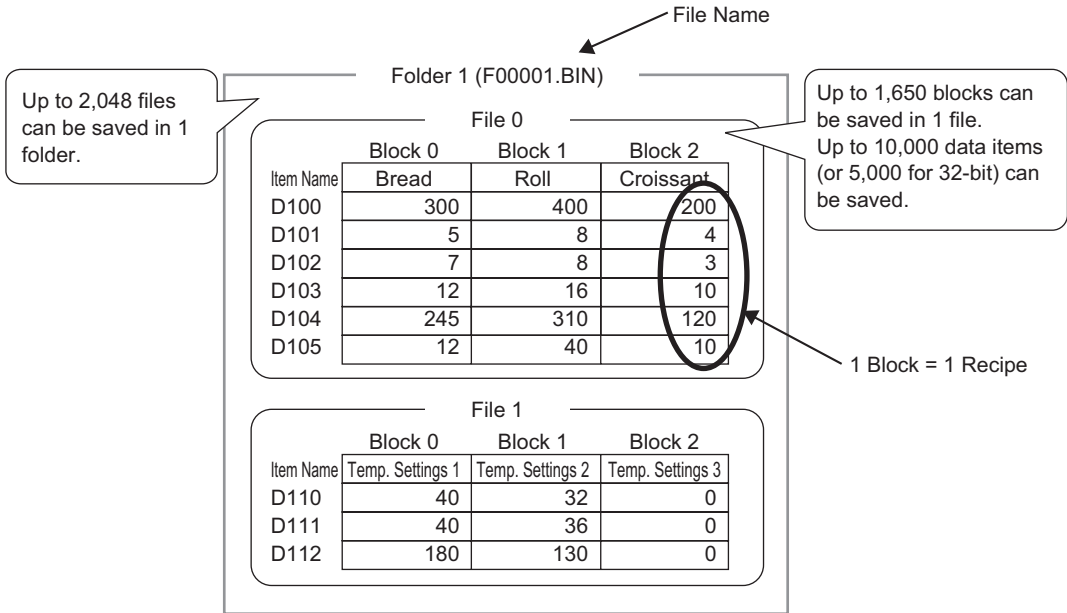

- NOTE**
- The number of files, blocks, and data that can be set changes depending on the ratio of each one.
 - You can also register files in multiple folders. Up to 8,999 folders can be registered, but only one folder can be stored in backup SRAM.

Transfer Preparation when using Multiple Folders

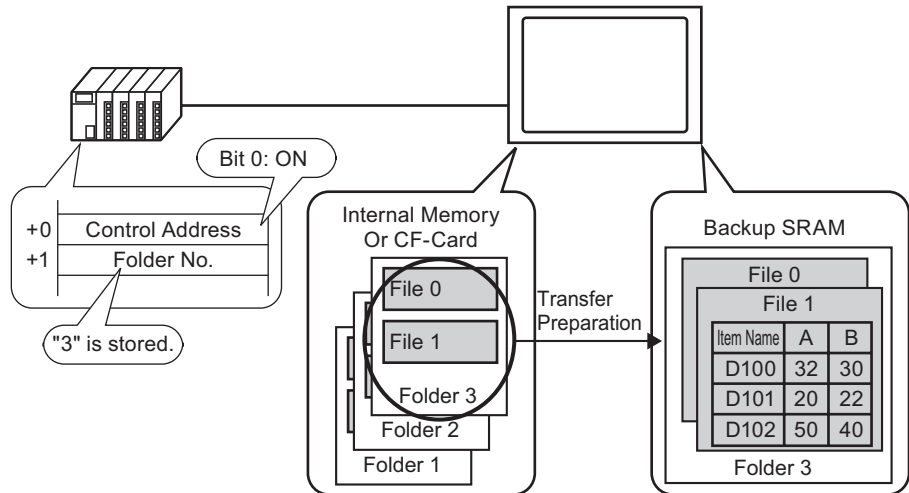

■ Backup SRAM

This memory will save data even when the GP unit's power is OFF.

The backup SRAM user area is used to backup filing data, Alarm History data, Sampling data, and the internal device (User Area).

The capacity of backup SRAM that can be used by filing data depends on the model of GP and how much capacity is being used by other data.

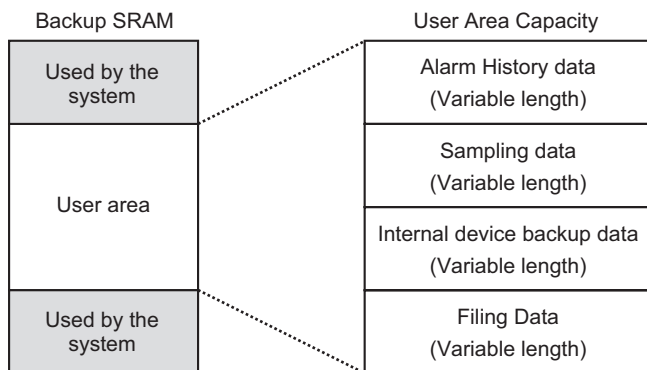

The backup SRAM user area has the following usage priorities:

- (1) Alarm History data
- (2) Sampling data
- (3) Internal Device backup data
- (4) Filing data

IMPORTANT

- Data in backup SRAM is erased when:
 - Screen transfer occurs
 - the user area is initialized (Offline)
 - Backup SRAM is initialized (Offline)
 - Data stored in backup SRAM can be saved to the CF-card. Set it with System Settings [Main Unit Settings] - [Action Settings] tab - [CF-Card Data Storage].
 ☞ “◆ Action Settings” (page 6-94)
-

◆ **Filing Data Capacity**

The maximum storage capacity of filing data per file is the maximum capacity of the backup SRAM user area. Folder capacity is calculated in the following way, depending on the number of files, blocks, data, and the bit length.

Calculation

- Usage capacity per file (in bytes)

$$118 + \{(68 + 2^{*1} \times \text{No. of Data}) \times \text{No. of Blocks}\}$$

*1 2 bytes when the data length is 16 bit, 4 bytes when the data length is 32 bit.

- Usage capacity per folder (in bytes)

$$4 + \text{the sum of each file's volume}$$

Calculation Example

Item	Description
No. of Blocks	5
No. of Data	1,000
Data format (bit length)	16 Bit

e.g.) Folder capacity with only 1 file

[Calculation result]

$$4 + [118 + \{(68 + 2 \times 1,000) \times 5\}] = 10,462 \text{ bytes (around 10 KB)}$$

25.12.2 Transferring Item Name and Block No.

If you touch the [Edit Filing Data] dialog box's [Option], you can configure settings to transfer data with the item name and block number attached to it.

When transferring both the item name and block number to the device/PLC along with the data, it will be stored with the following structure.

e.g.) [Storage Start Address] is a 16 bit address, data is 16 bit

The screenshot shows the 'Edit Filing Data' dialog box with the following settings: File No. 0, Comment 'Ingredient', Storage Start Address '[PLC1]D00110', No. of Blocks 3, Display Format 'Dec', Sign +/-, No. of Data 6, Bit Length 16 Bit, and Language Settings 'ASCII'. The table below shows item names and their corresponding block numbers:

Item Name	Block 0	Block 1	Block 2
[PLC1]D00127	Bread 350	Butter Roll 400	Croissant 200
[PLC1]D00128	5	8	4
[PLC1]D00129	7	8	8
[PLC1]D00130	12	16	10
[PLC1]D00131	245	310	120
[PLC1]D00132	12	40	10

The diagram on the right shows the storage structure in a Device/PLC:

- D110: Block No. 1
- D111: Item Name (32 characters)
- D126: Data
- D127: 400
- D128: 8
- D129: 8
- D130: 16
- D131: 310
- D132: 40

IMPORTANT

- The item name's text will be stored according to the Text Data Mode settings.*1
 - Storage of the item name and data depends on the designated [Storage Start Address] and [Bit Length].
 - The block number will not be transferred during a device/PLC to SRAM transfer. The same applies when transferring via the internal device (Device/PLC → Internal Device → SRAM).
 - When using manual transfer via the internal device, the item name will be sent between the SRAM and the internal device regardless of settings in the [Option Settings] dialog box.
- e.g.) When only [Send Block No.] is designated

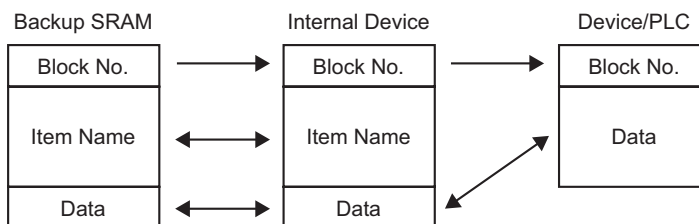

NOTE

- When the Item Name is less than 32 characters, spaces will be appended automatically.
- Even when the [Display Format] is set to [BCD], the Block No. will be stored in the device/PLC with binary data.

*1 Text Data Mode settings are configured in the System Settings' [Device/PLC Settings].

25.12.3 Manual Transfer Via the Internal Device

When a Special Data Display [Filing] is set with [Via Internal Device], you can use a Switch Lamp [Special Switch] - [File Item Switch] for the following transfers: “SRAM → Internal Device”, “Internal Device → Device/PLC”, “Device/PLC → Internal Device”, and “Internal Device → SRAM”.

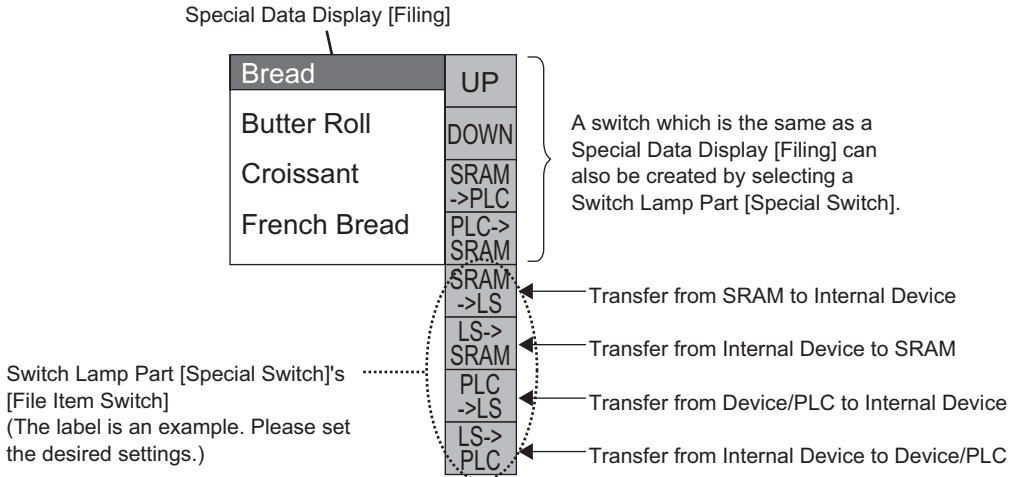

NOTE • A Switch to operate the transfer to and from the internal device can only be created with a Switch Lamp [Special Switch].

e.g.) When transferring from SRAM → Internal Device (Start Address: LS20) → Device/PLC
(Data length: 16 Bit)

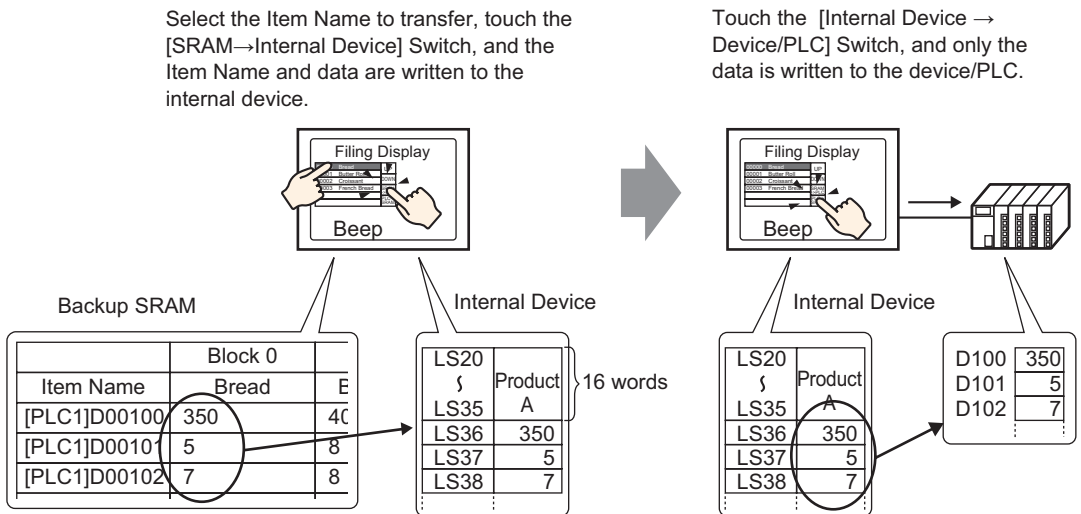

Data stored in the internal device can be displayed as needed on the GP screen in a Data Display [Numeric Display]. This can be used when you want to want to make small adjustments to the the data on the GP screen before transferring it to the device/PLC.

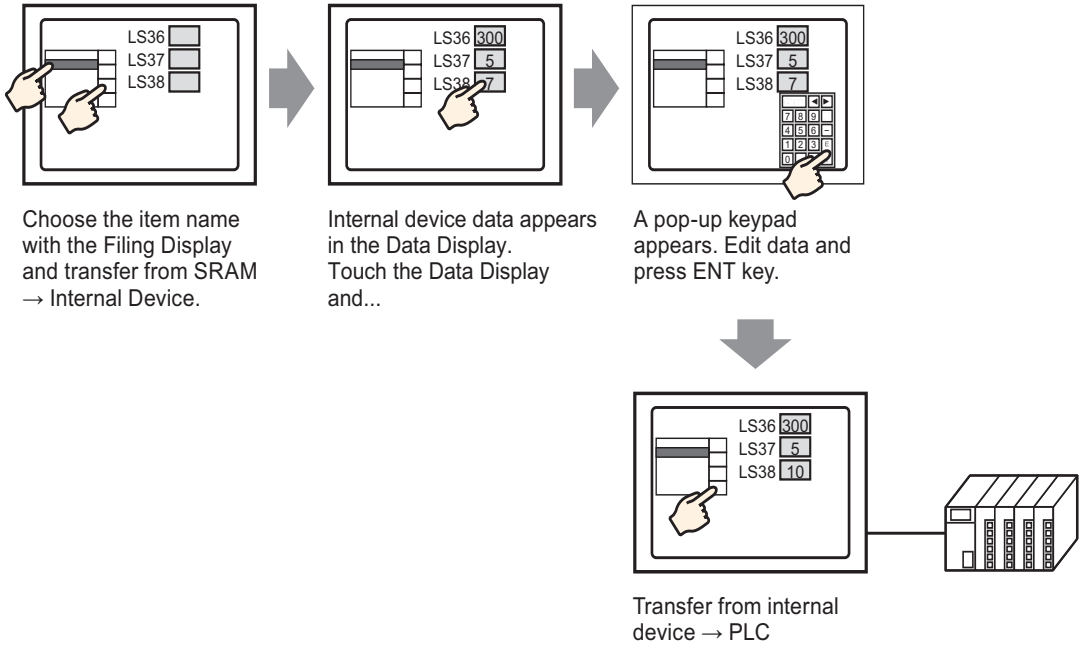

◆ Structure of Filing Data Stored in the Internal Device

When transferring data from backup SRAM to the internal device, the 16 consecutive words after the designated [Storage Start Address] will store the item names, and data will be stored after that.

The item name's text will be stored according to the Text Data Mode settings.*1

E.g.) When data is 16 bit

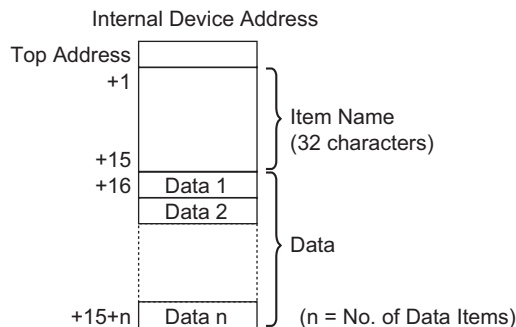

NOTE • When data is 32 bit, the used data portion will be No. of Data × 2 words.

*1 Text Data Mode settings are configured in the System Settings' [Device/PLC Settings].

When transferring data from the internal device to the device/PLC, only data stored in the internal device is written to designated addresses in the device/PLC.

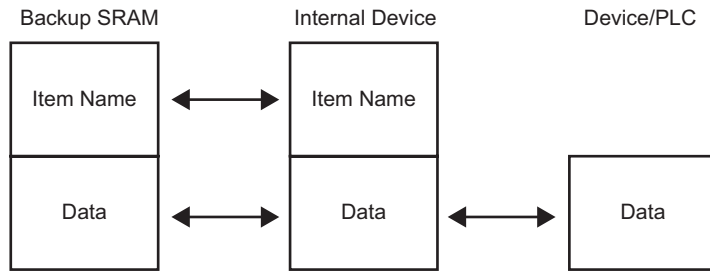

-
- NOTE** • If [Send Item Names] is set when creating data, you can also transfer item names to the device/PLC.
☞ “25.12.2 Transferring Item Name and Block No.” (page 25-109)
-

25.13 Restrictions

25.13.1 Restrictions on Transferring CSV Data

- The maximum number of data items that can be set in one file (ZR*****.csv) is 10,000 (or 5,000 when the data is 32 bit).
- If the number of data items is large, transfer may take some time. The time between transfer start and transfer end can be from several seconds to several minutes.
- While a transfer is occurring, the display of Parts may not update properly or may become slow. Screen changes and other operations may also slow down.
- If a screen change occurs during transfer, in order to read the screen information, the transfer may take some time.
- Please wait until a transfer completes before initiating another one. If a transfer is started before the previous one ends (such as when an automatic transfer and manual transfer occur at the same time), the second transfer operation may not be accepted.
- If there are many files in the CF-card's [FILE] folder and a transfer occurs from device/PLC to CF-card, the write time can be from several seconds to several minutes.
- Please do not call up CSV data transfer screens and other screens that use the CF-card when the CF-card is not installed in the GP. If you do, they will not function properly.
- If a CF-card error occurs, any file that has not finished loading may remain on the CF-Card.
- When overwriting a file by transferring data to the CF-card, the CF-card must have enough free space to allow the data. If the data is larger than the available space, a CF Write Error will occur.
- When saving to the CF-card, if the target folder (\FILE) does not exist, a folder will be automatically created, and the data will be saved there. However, if the CF-card is not reset or any other case occurs where the folder cannot be created, a CF-card error will occur.
- There is a limit to the frequency that data can be rewritten to the CF-card. (500 KB of data can be rewritten around 100,000 times) Please make sure to backup to another media.
- When saving data in a CF-card, you cannot use a file name or folder name with two-byte characters. The file name/folder name should be 8 single-byte characters or less.

■ CF-Card Usage Warnings

- When removing the CF-card, please verify that the access lamp is switched off. If it is on, there is a chance that CF-card data can be lost or damaged.
- While accessing the CF-card, do not turn the GP unit off, reset the GP, or remove the CF-card. Create a preset verification screen for information about CF-card access. Turn off power, reset, open the CF-card cover, or remove the CF-card only after verifying that screen.
- When inserting the CF-card in the GP unit, please make sure you have the correct side up and the correct location for the CF-card connector. If installed incorrectly, damage can occur to the data or to the CF-card/GP unit.
- Please use a CF-card made by Digital Electronics Corporation. If using another company's CF-card, damage may occur to the CF-card's data.
- Please make sure to backup all CF-card data.

- Please refrain from doing the following, as it can result in damage to data and equipment:
 - Bending the CF-card
 - Dropping the CF-card
 - Pouring water on the CF-card
 - Touching the CF-card's connectors directly
 - Disassembling or modifying the CF-card

■ Restrictions for Manual Transfer

- First set the Condition Settings on [Recipe Settings] - [Transfer CSV Data (Condition Settings)], then place the Special Data Display [Data Transmission] on the screen.
- Only one Special Data Display [Data Transmission] can be placed per screen.
- Up to 32 Special Data Display [Data Transmission] parts can be placed per project.
- When selecting transfer files by touch, multiple files can only be selected from the area displayed in a Special Data Display [Data Transmission]. (The maximum number of display rows is 50.)

If the displayed page is changed with the [Data Transmission]'s scroll switches, the selection will be cancelled.

- If an error occurs while multiple files are being transferred, transfer of those files will be interrupted. Subsequent files will not be transferred.
- When transferring data from the device/PLC to CF-card, the device/PLC data will be saved in the file designated in the Special Data Display [Data Transmission]. In that case, the Condition Name (GROUP NAME) will be overwritten by the Condition Name designated in the common settings' condition settings.
- If the number of data items designated in the condition settings differs from that in the file, the smaller number of data items will be transferred.
- Please ensure that the file numbers set in the condition settings ([Start No.] to [Termination No.]) are not repeated in multiple conditions. If file numbers are repeated in several conditions, data will be transferred according to the condition with the smaller number.

■ Restrictions on Automatic Transfer (Conditional Action)

- A maximum of 64 files can be transferred at one time.
- If an error occurs while multiple files are being transferred, transfer of those files will be interrupted. Subsequent files will not be transferred. Transfer occurs in order starting from the top file number storage address.
- If the number of data items designated in the condition settings differs from that in the file, the smaller number of data items will be transferred.
- Please ensure that the file numbers set in the condition settings ([Start No.] to [Termination No.]) are not repeated in multiple conditions. If file numbers are repeated in several conditions, data will be transferred according to the condition with the smaller number.
- If the number of files is "0", no data will be transferred even when the [Control Word Address] turns ON. Also, status will not restart.

- When transferring from device/PLC to CF-card, if the target folder (\FILE) does not exist, the [FILE] folder will be automatically created, and the data will be saved there. However, if the CF-card is not reset or any other case occurs where the folder cannot be created, a CF-card error will occur.

■ Restrictions on Automatic Transfer (Address Action)

- One file (CSV data) can be transferred at a time.
- When transferring CSV data from CF-card to device/PLC using a memory link connection, designate the [Address Mode] as “0”.
- If the number of data items exceeds the set range (10,000 when the data length is 16 bit, 5,000 when it's 32 bit), any excess values will not be transferred.
- Please set the device code/address code correctly. If the address for a device is outside the range or refers to a device which does not exist, a communication error will occur and the screen will freeze.

If a communication error occurs, when transferring from device/PLC to CF-card, check the device code/address code you have specified, change it to a correct address and turn ON bit 1 of the [Control Word Address] again to recover from the error. When transferring from the CF-card to the device/PLC, the GP cannot recover from the error unless the power is turned OFF and ON again or reset.

- When transferring from device/PLC to CF-card, if the target folder (\FILE) does not exist, the [FILE] folder will be automatically created, and the data will be saved there. However, if the CF-card is not reset or any other case occurs where the folder cannot be created, a CF-card error will occur.

25.13.2 Restrictions on Displaying/Editing/Printing CSV Data

■ Display Restrictions

- Only one Special Data Display [Show CSV] can be placed per screen.
- Only one Special Data Display [File Manager] can be placed per Base Screen. It cannot be placed on a Window Screen.
- When you place a Special Data Display [Show CSV] on a Window Screen, you cannot edit the data. (The editing screen cannot be triggered.)
- You cannot set a Special Data Display [Show CSV] at the same time as a Sampling Data Display or Data Display (a Numeric Display with [Input Permit] set or a Text Display).
- The Special Data Display [File Manager] cannot be scaled up or down.
- When placing a Special Data Display [File Manager], specify the X coordinate in 4-dot increments. If you place it in a different position, it will not be displayed in the exact position it was on the screen with GP-Pro EX because the GP corrects the display position.
- A Special Data Display [File Manager] is displayed using a Special Window or Local Window. If the maximum number of windows are already displayed, the File Manager cannot display. Close another window and touch the Display switch to bring up the File Manager Display.

 “18.8 Restrictions for Windows” (page 18-28)

- When a text table changes, the Special Data Display [File Manager] will be automatically closed.
- When using a Switch Lamp part's Special Switch [File Manager Display Switch], please do not set the switch on a Window Screen. Even if set, the Special Data Display [File Manager] will not appear on the Window.
- If more than one display switch for a Special Data Display [File Manger] is set up on a single screen, only one File Manager will function. Touching another display switch while a File Manager is already displayed will close the File Manager window currently displayed.
- Files currently displayed on a Special Data Display [Show CSV] cannot be deleted with a Special Data Display [File Manager].
- When updated because of a transfer from the device/PLC to CF-card, displayed CSV data is updated and rewritten.
- If the CF-card is removed or the cover of the CF-card slot is opened while CSV file data is displayed, the display will be automatically cleared.
- If the screen changes while CSV data is displayed, the display will be cleared.
- There are two valid data formats for CSV data displayed in a Special Data Display [Show CSV]: data delimited by ["] (double quotation marks), and data separated by [,] (commas).

e.g.) CSV format (Sampling data)

```
"", "Date", "Time", "Data 0", "Data 1"
"No.1", "01/12/05", "09:00:00",
"123.4", "780"
"No.2", "01/12/05", "10:00:00",
"213.5", "235"
```

```
, Date, Time, Data 0, Data 1
No. 1, 01/12/05, 09:00:00, 123.4, 780
No. 2, 01/12/05, 10:00:00, 213.5, 235
```

■ Restrictions for Editing

- The editing screen for a Special Data Display [Show CSV] is displayed using a Special Window or Local Window. If the maximum number of windows are already displayed, the editing screen cannot be activated. Close another window before editing the data.  "18.8 Restrictions for Windows" (page 18-28)
- You can edit up to 56 digits of characters with a Special Data Display [Show CSV] (Only for the GP-3300 series, Horizontal: 32 digits, Vertical: 24 digits).
- The CF-card data-saving function (the function that retrieves data from backup SRAM, converts it into CSV format, and saves it to a CF-card) is disabled during editing. If this function is attempted, a CF Write Error occurs.
- If a file's contents changed during editing (from a device/PLC to CF-card transfer, etc.), a CF Write Error will be stored in the [Status Address] and the displayed data will not be updated.
- When a text table changes, the editing screen will be automatically closed.
- Even when the [Interlock Address]'s state matches the [Touch Enable Condition] during editing, editing can be performed. However, if editing is attempted again, the screen will not enter Edit mode because the Interlock feature is enabled.
- Numeric values displayed on a Special Data Display [Show CSV] are displayed as text. Therefore, the inputs will be edited regardless of properties such as the number of display digits, data length, and data type.

- While the edited data is being output to a CSV file, printing and editing modes are disabled. Also, the system cannot be switched to off-line mode.
- Regardless of the Show Column settings, the column portion cannot be edited.
- When editing data, a temporary file is created in the CF-card after the editing is confirmed with the [ENT] key. Therefore, editing cannot be performed unless the system has an amount of free space equivalent to or larger than the file to be edited. If there is not sufficient free space, the file cannot be edited.

When editing data, the internal processing updates the file in the following way:

e.g.) When editing “ZR0001.CSV”

- (1) After editing and pressing the [ENT] key, a temporary file (a file that reflects the editing results), “_CSV\$\$_0.TMP”, is created.
- (2) The original file name is changed from “ZR0001.CSV” to “_CSV\$\$_1.TMP”.
- (3) “_CSV\$\$_0.TMP” is changed to “ZR0001.CSV”.
- (4) “_CSV\$\$_1.TMP” is deleted.

If the power turns OFF during editing or editing fails, the “_CSV\$\$_0.TMP” and “_CSV\$\$_1.TMP” files may remain in the CF-card.

- When a Special Data Display [Show CSV] is rotated by 90 or 180 degrees, the editing screen characters will not be displayed properly. To place a rotated [Show CSV], set rotation to 0 or 270 degrees.

■ Restrictions for Printing

- The horizontal lines are not printed.
- Any portion that exceeds an A4 width will not be printed. The number of characters that can be printed on one line depends on the printer.
- Up to 160 characters can be printed in a single line. Any text exceeding 160 characters will be cut off.
- Regardless of the Show Column settings, the column portion will not be printed.
- When printing only the displayed portion, if the data in the rightmost cell extends beyond the screen and is cut off on the Show CSV Display, that portion will also be cut off on the printout.
- While printing, you cannot edit data or execute other print jobs. Also, the system cannot be switched to off-line mode.

25.13.3 Restrictions on Transferring Filing Data

- When using multiple folders, up to 8,999 folders can be registered. However, only one folder can be stored in backup SRAM.
- One folder’s capacity can be up to the maximum capacity of the backup SRAM (the maximum capacity when only filing data is stored).
Even when filing data is stored in the CF-card, regardless of the CF-card’s memory capacity, one folder can be up to the backup SRAM’s maximum capacity.
- Up to 2,048 files can be set in one folder.
- Up to 1,650 blocks can be saved in one file. (The maximum number changes depending on the No. of Files and No. of Data.)

- The maximum number of data items in one block is 10,000 (or 5,000 when the data is 32 bit). (The maximum number changes depending on the No. of Files and No. of Blocks.)
- If the number of data items to transfer is large, writing to the device/PLC may take some time. The time between transfer start and transfer end can be from several seconds to several minutes.
- While writing to a device/PLC, the display of Parts may not update properly or may become slow. Screen changes and other operations may also slow down.
- If a screen change occurs during transfer, in order to read the screen information, it may take some time to write to the device/PLC.
- Please wait until the transfer completes before initiating another one. If a transfer is started before the previous one ends (such as when an automatic transfer and manual transfer occur at the same time), the second transfer operation will not be accepted.
- Data in backup SRAM is erased when:
 - Screen transfer occurs
 - Memory is initialized (Offline)
 - Backup SRAM is initialized (Offline)
- When placing multiple Special Data Displays [Filing] on one screen, be sure not to use the same [Identification No.] for multiple Displays.

Memo