

7 **Communicating with Multiple Device/PLCs**

This chapter explains about communicating to the GP with multiple devices/PLCs, and the basic operations used to sever communication and change devices/PLCs.

Please start by reading “7.1 Settings Menu” (page 7-2) , and then turn to the corresponding page.

7.1	Settings Menu	7-2
7.2	Connecting to Multiple Devices (PLCs).....	7-3
7.3	Disconnecting Some of the Multiple Connected Devices/PLCs.....	7-11
7.4	Changing a Device/PLC.....	7-18
7.5	Settings Guide.....	7-28
7.6	Restrictions	7-33

7.1 Settings Menu

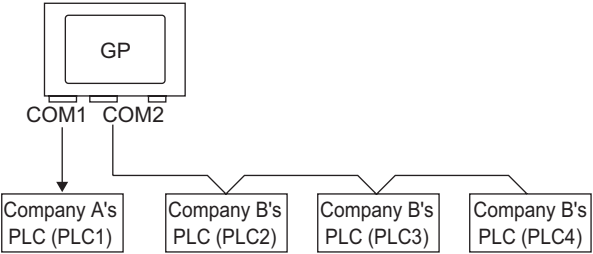
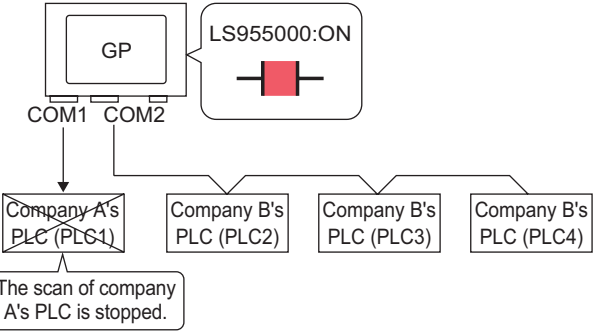
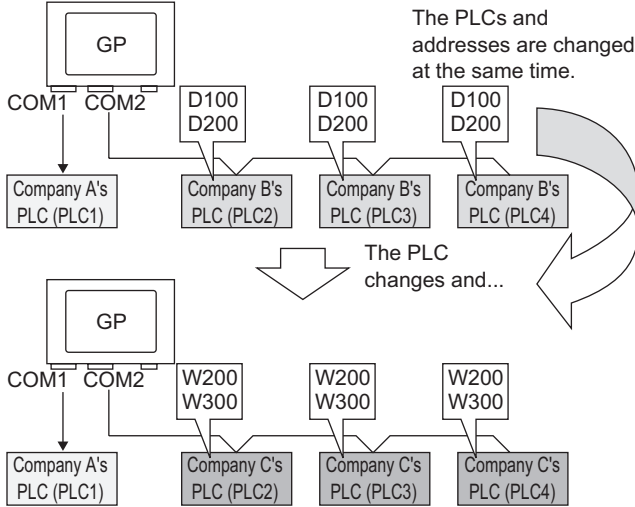
Connecting to Multiple Devices (PLCs)	
	<ul style="list-style-type: none"> ☞ Setup Procedure (page 7-4) ☞ Details (page 7-3)
Disconnecting Some of the Multiple Connected Devices/PLCs	
 <p>The scan of company A's PLC is stopped.</p>	<ul style="list-style-type: none"> ☞ Setup Procedure (page 7-12) ☞ Details (page 7-11)
<p>You can stop each device/PLC's scan in the active mode by operating each bit for the communication ON/OFF.</p>	
Changing a Device/PLC	
 <p>The PLCs and addresses are changed at the same time.</p> <p>The PLC changes and...</p>	<ul style="list-style-type: none"> ☞ Setup Procedure (page 7-19) ☞ Details (page 7-18)

7.2 Connecting to Multiple Devices (PLCs)

7.2.1 Details

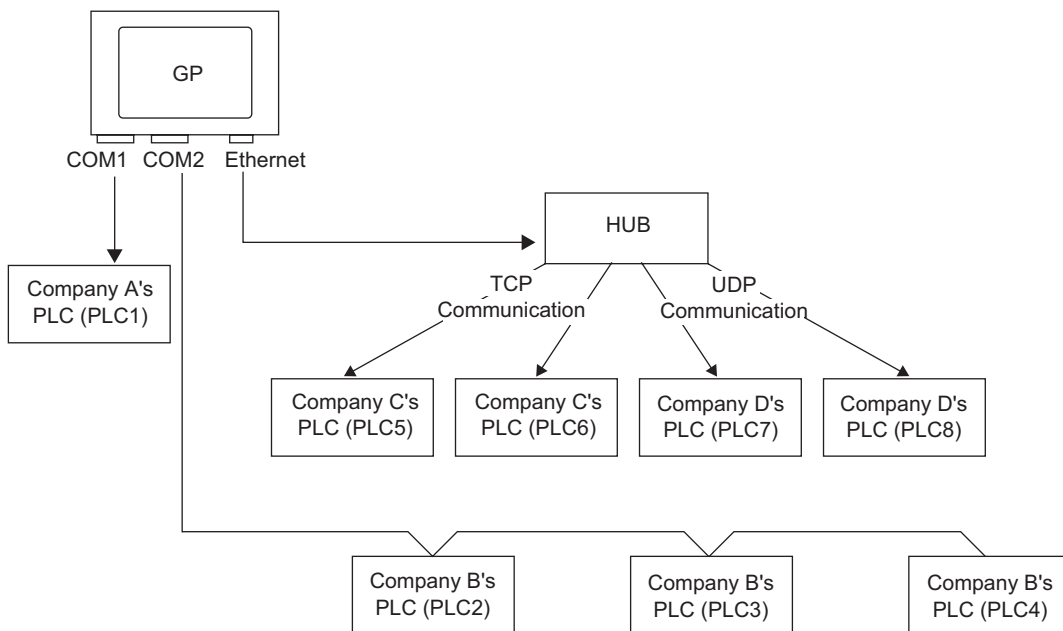

With one GP unit, 4 drivers can be used (COM1, COM2, Ethernet (UDP/TCP)) and multiple devices can be connected simultaneously.

Some types can support up to 4 drivers and some types can support up to 2 drivers.

NOTE • The GP330X series can only support up to 2 drivers.

7.2.2 Setup Procedure

NOTE • Please refer to the settings guide for details.
 ☞ “6.13.2 [New] Settings Guide” (page 6-66)

e.g.) COM1: Company A's PLC, PLC1 (e.g.: Omron, CS/CJ Series HOST Link)
 COM2: Company B's PLCs, PLC2, PLC3, PLC4 (e.g.: Mitsubishi, A Series Computer Link). Configure settings to add these 3 PLCs.

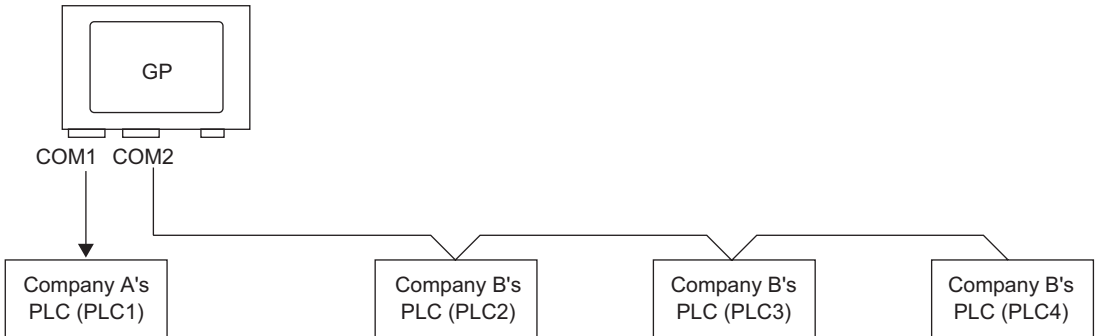

1 Select the [Project (F)] menu - [System Settings (C)] command, or click  and click the System Settings Window's [Device/PLC Settings]. The following [Device/PLC Settings] screen will appear.

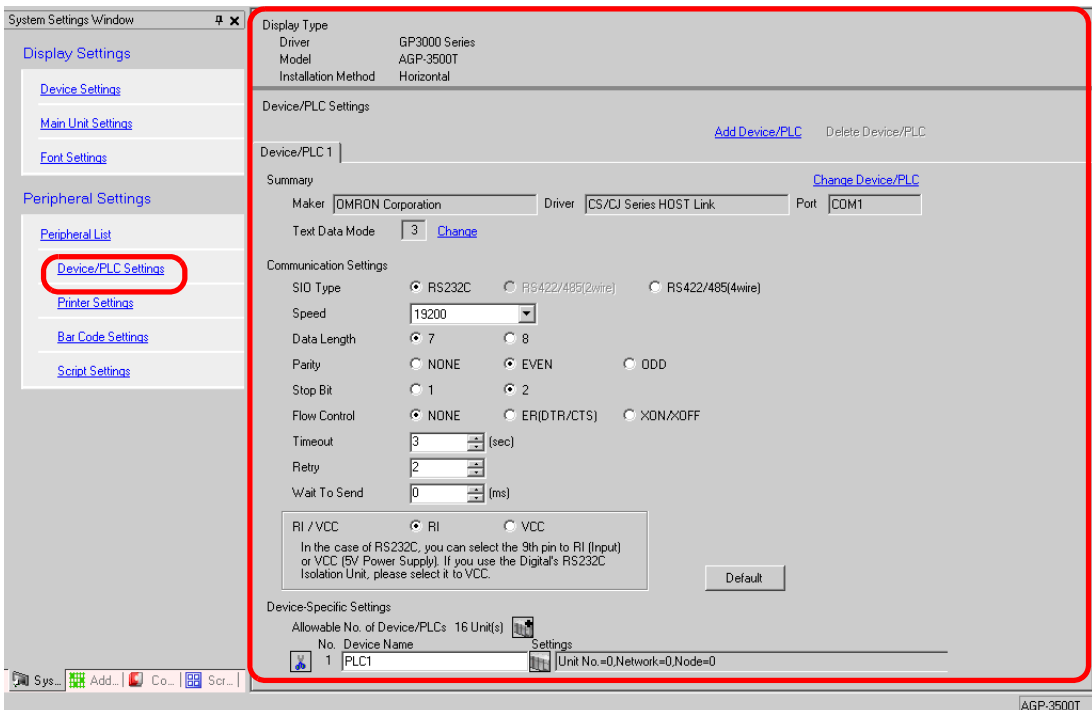

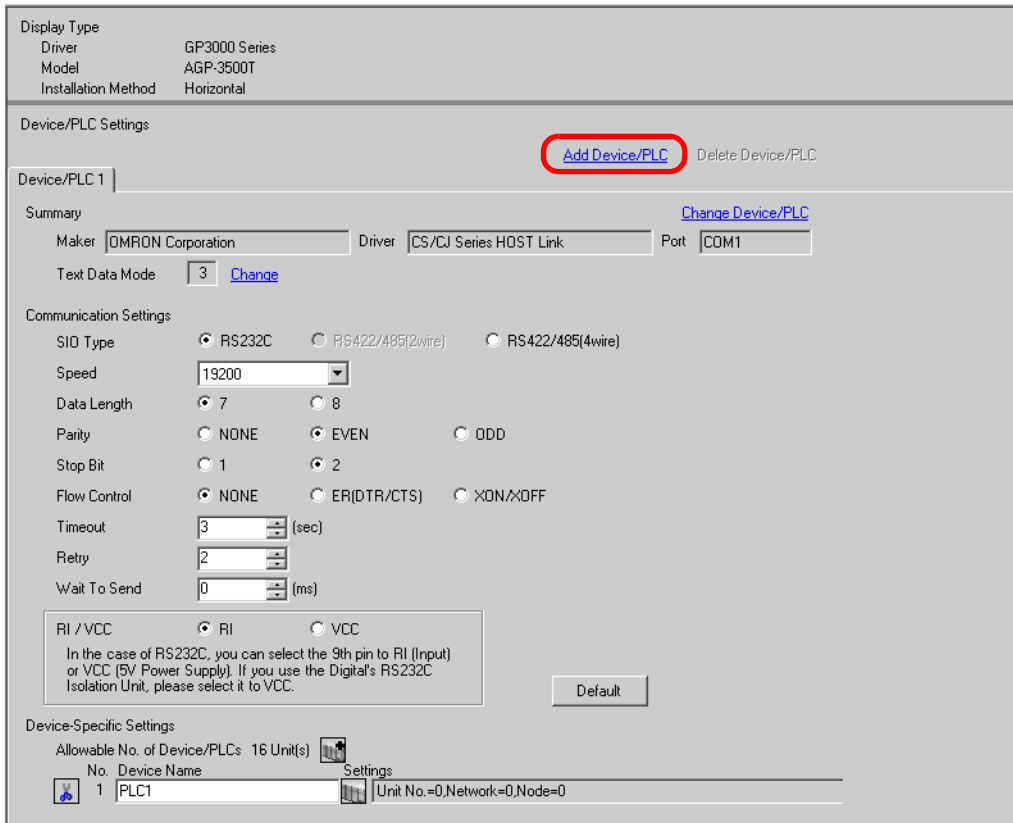

2 Click [Add Device/PLC].

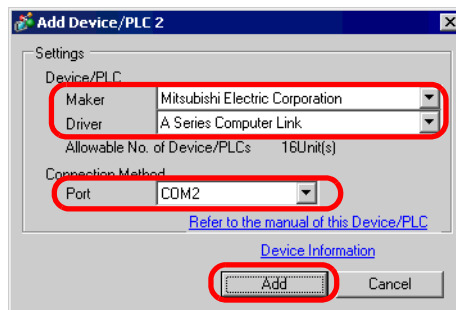

3 When the [Add Device/PLC 2] dialog box appears, set the [Maker], [Driver], and [Port] for the PLC you want to add, and click [Add].



- NOTE** • Make sure not to choose a port that is already used by another PLC. If the port has multiple PLCs,  will appear to the right of the [Device/PLC Settings] screen's [Port] label.

4 When the [Device/PLC 2] tab's Settings Screen appears, click the [Add Device Button]  and add 2 PLCs.

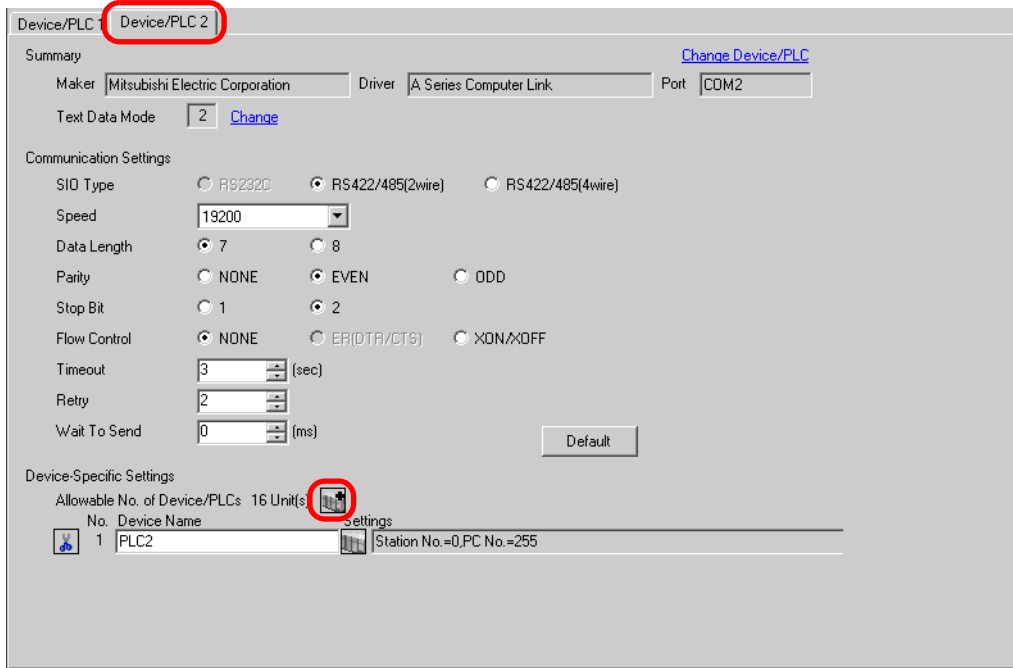

NOTE • Every time the [Add Device Button]  is clicked, 1 PLC is added.

5 Set the name of each added PLC with up to 20 single-byte characters.

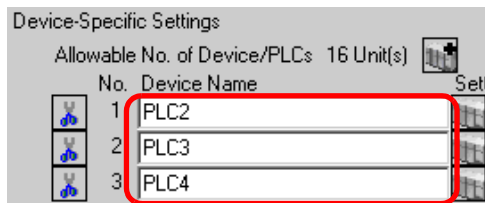

NOTE • When adding the desired [Device Name], please ensure not to use a repeated name.

- 6 Click the [Device/PLC Settings Button] , and when the [Individual Device Settings] dialog box appears, set each corresponding PLC. (The following image shows the [Individual Device Settings] dialog box used for the Mitsubishi A Series Computer Link type.)

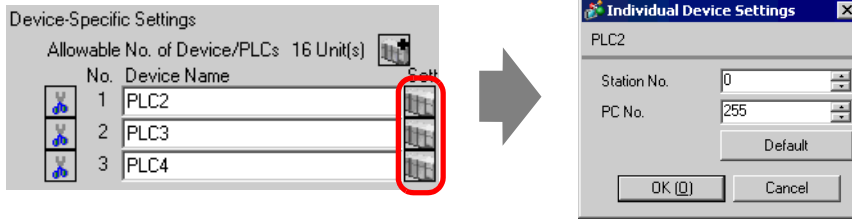

-
- NOTE** • The [Individual Device Settings] dialog box settings differ depending on the PLC. For more information on each PLC's settings, please refer to "GP-Pro EX Device/PLC Connection Manual".
-

- 7 The above multiple PLCs have now been added.

7.2.3 Structure

■ Multiple Connected Patterns

◆ Direct Access Method

- Multiple PLCs can be connected.

(1) When using COM1 and COM2

e.g.) Company A's driver (serial communication) is set to COM1, and Company B's driver is set to COM2 (serial communication).

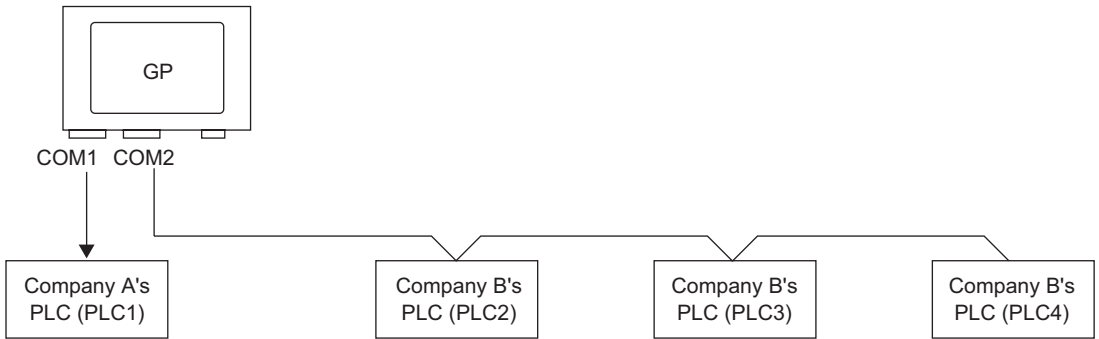

- NOTE**
- A different driver can be designated for each COM port. However, each COM port can only have a single driver.
 - COM port 1 can have multiple devices with the same driver connected to it. However, the number of devices that can be connected depends on the driver. For more information about the Allowable No. of Device/PLC s, please refer to “GP-Pro EX Device/PLC Connection Manual”.

(2) When using COM1 and an Ethernet port ([UDP]/[TCP] communication)

e.g.) Company A's driver (serial communication) is set to COM1, and Company B, C, and D's drivers are set to the Ethernet port (Ethernet communication).

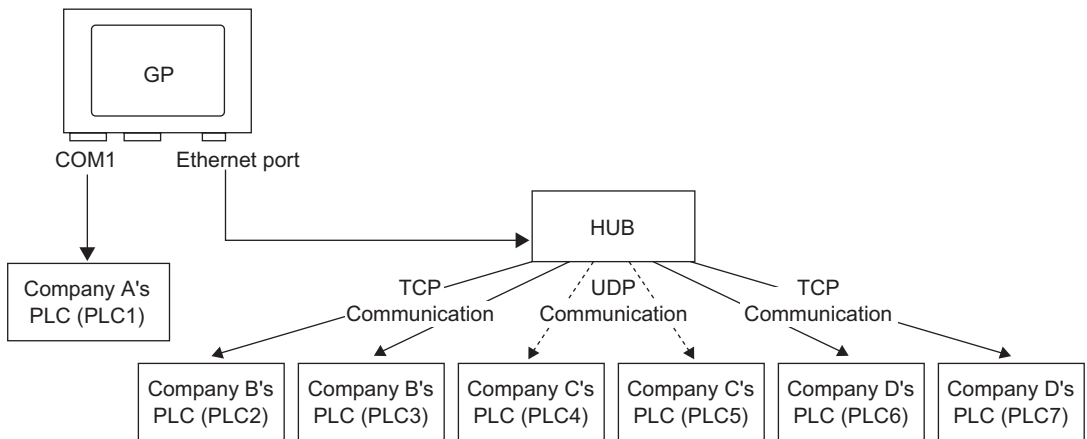

- NOTE**
- A maximum of 4 drivers can be setup for the Ethernet port. However, when using the COM port, only $(4 - (\text{No. of used COM ports}))$ drivers can be set up for the Ethernet port. In the above example, COM1 has one driver set up (Company A's PLC), so the Ethernet port can handle 3 additional types of drivers (Company B, C, and D).

NOTE

- When using an Ethernet communication driver with multiple connections, [UDP] or [TCP] can not be set up in the same driver.
e.g.) When [Device/PLC 1] has been set to MELSEC A Ethernet [UDP] type, [Device/PLC 2] can not be set to MELSEC A Ethernet [TCP] type.

◆ Direct Access Method + Memory Link Method

- Devices/PLCs and hosts (PCs, Microcomputer boards, etc.) can be connected at the same time.

(3) When using Direct Access Method and Memory Link Method

e.g.) Company A's PLC is connected to COM1 by direct access method, and the microcomputer board is connected to COM2 by memory link method.

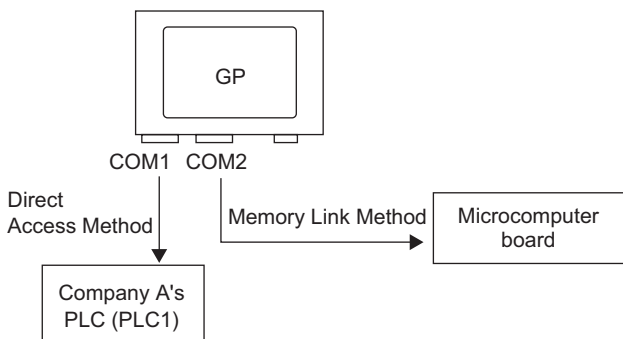

■ System Data Area/LS Area when Multiple Device/PLCs are used

For more information about the system data area, please refer to “A.1.4.4 Device/PLC’s System Data Area Allotment Procedure” (page A-19) or the “GP-Pro EX Device/PLC Connection Manual”.

◆ Direct Access Method

When multiple PLCs are connected to the GP, the system data area can only have one PLC connected to it.

e.g.) As in the following image, when the GP unit has 4 connected PLCs, only one of those can be set to the system data area.

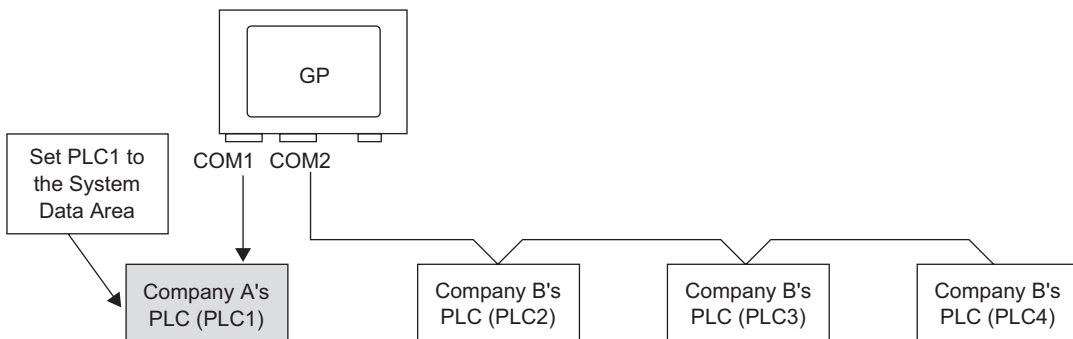

◆ **Direct Access Method + Memory Link Method**

When communicating by both direct access method and memory link method, a separate area will be used for the LS area of each method. However, the system data area, the special relay area, and the LS9000 area will be mutually linked.

e.g.) As in the following image, when a PLC and microcomputer board are both connected to the GP, the GP has a direct access method LS area and a memory link method LS area.

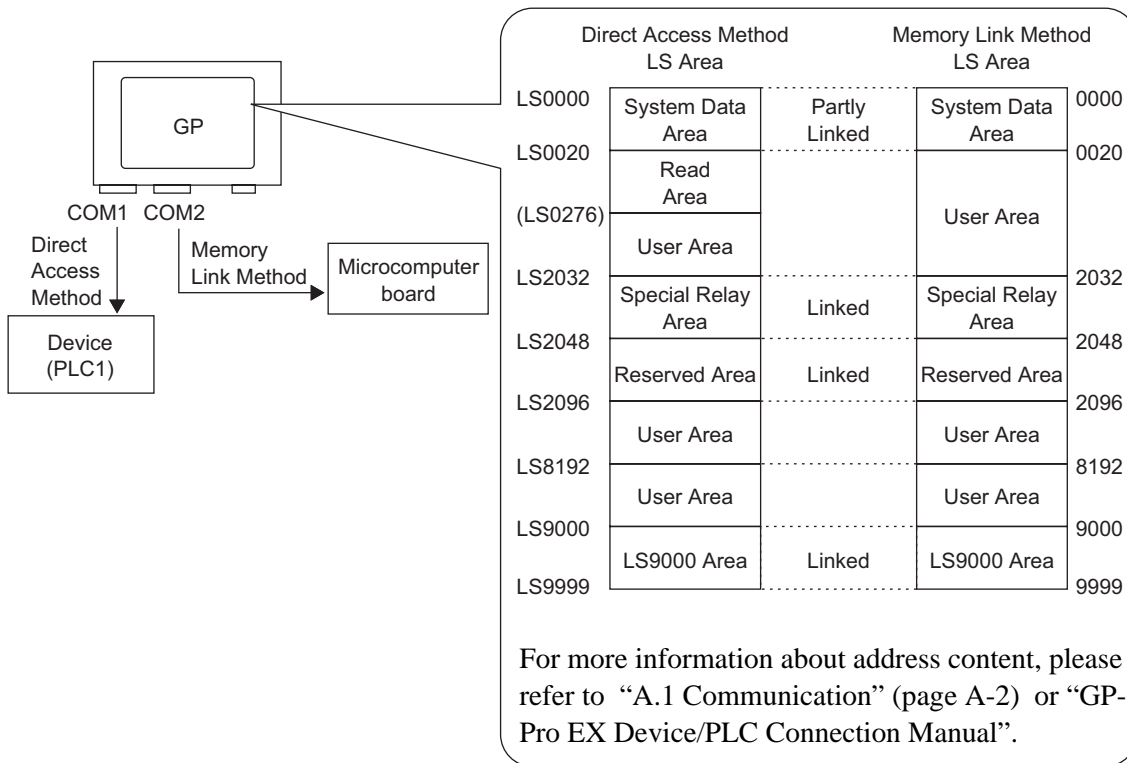

7.3 Disconnecting Some of the Multiple Connected Devices/PLCs

7.3.1 Details

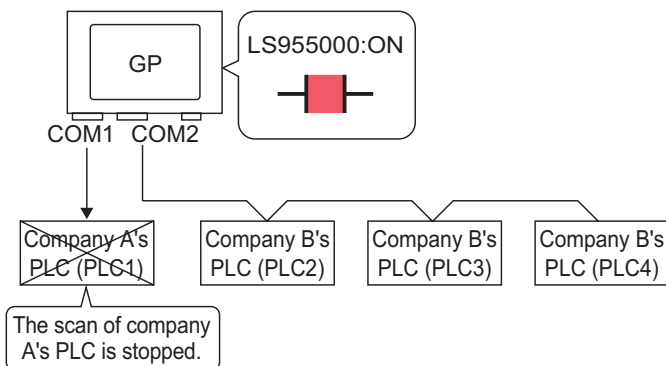

You can stop each device/PLC's scan in the active mode by operating each bit for the communication ON/OFF.

7.3.2 Setup Procedure

NOTE

- Please refer to the settings guide for details.
 - ☞ “11.14.1 Bit Switch” (page 11-44)
 - ☞ “7.5 Settings Guide” (page 7-28)
- For details about placing parts or setting addresses, shapes, colors, and labels, please refer to the “Part Editing Procedure”.
 - ☞ “9.6.1 Procedure for Editing a Part” (page 9-36)

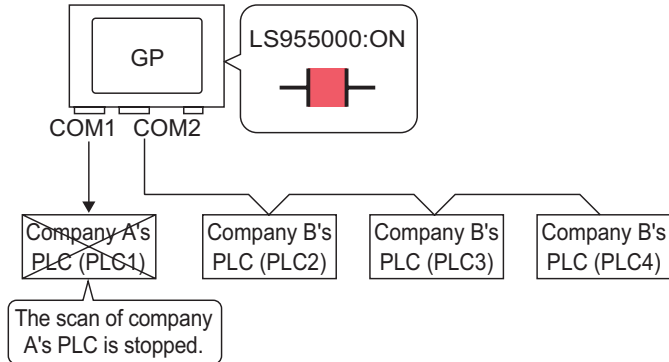

You can stop each device/PLC's scan in the active mode by operating each bit for the communication ON/OFF.

■ Disconnecting the Communication

Create a switch to reverse the Bit Address ON/OFF that controls each device/PLC's communication scan by touch.

- 1 Select the [Part (P)] menu - [Switch Lamp] option - [Bit Switch (B)] command or click  to place a lamp on the screen.
- 2 Double-click the placed Switch and the settings dialog box opens.

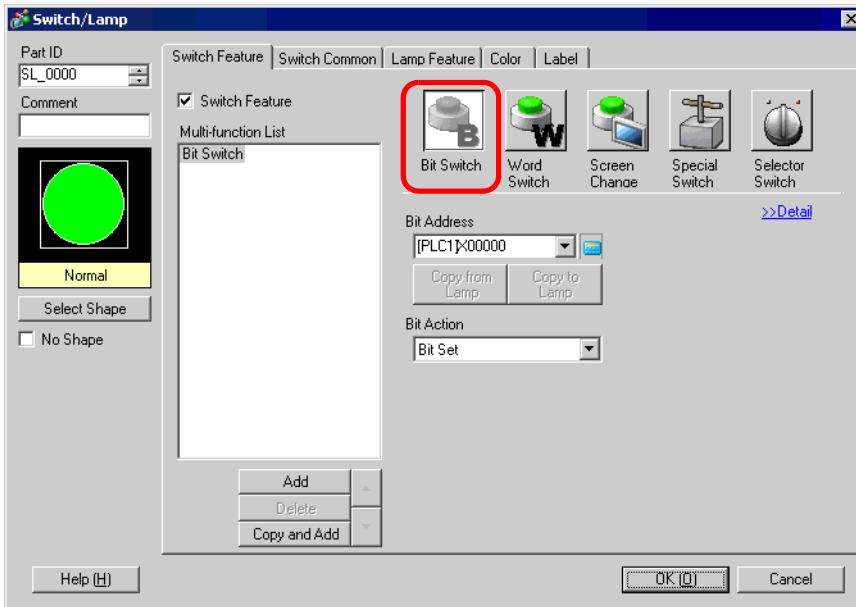

- 3 Select the Switch's shape from [Select Shape].

- 4 Set the Bit Address you want to operate by touch (e.g.: LS955000) to the [Bit Address].

Click on the icon and an address input keypad is displayed.

Select [#INTERNAL] for the [Device/PLC] and "LS" for the Device, input "955000" in the address, and press the "Ent" key.

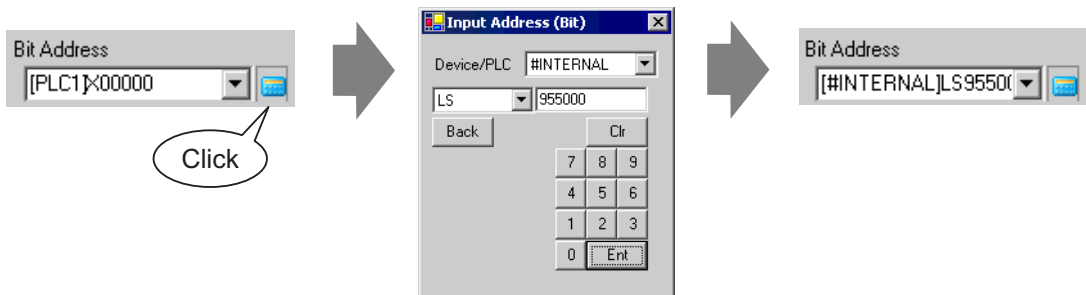

NOTE

- The setting range of the bit addresses to control whether to execute or to stop the communication scan is the internal device address' LS9550 to LS9557. Each device/PLC address starting from Bit 0 is assigned sequentially to each driver's device/PLC starting from the first unit.

LS Area	
LS9550	Driver 1's Machine 1 to 16
LS9551	Driver 1's Machine 17 to 32
LS9552	Driver 2's Machine 1 to 16
LS9553	Driver 2's Machine 17 to 32
LS9554	Driver 3's Machine 1 to 16
LS9555	Driver 3's Machine 17 to 32
LS9556	Driver 4's Machine 1 to 16
LS9557	Driver 4's Machine 17 to 32
LS9558	Reserved
LS9559	Reserved

e.g.)

You can set the bit addresses controlling the communication scan of the Driver 1's first to 16th units to LS9550.

[LS9550]

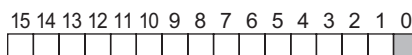

Bit 0: Scans ON/OFF the Driver 1's first PLC.

Stops the scan (scans OFF) of the Driver 1's first PLC by turning ON Bit 0. Turn OFF Bit 0 to resume the scan.

- You cannot stop the communication scan of a device specified with the System Area Start Address. However, if you are not using the System Data Area, you can stop the communication scan.
- ☞ "6.13.6 [System Settings Window] Setting Guide ◆ System Area Settings" (page 6-110)
- You can set the LS area's addresses with 32 bits on some devices/PLCs. In this case, the lower 16 bits are used for the bit addresses controlling the communication scan.
- When you turn OFF the communication scan, the displayed part's data will remain. However, if you change screens and then display the screen again, the part's data will not be displayed.

5 Choose [Bit Invert] from [Bit Action].



6 As needed, set the Switch's color and display text on the [Color] tab and [Label] tab, and click [OK].

■ Confirming the Communication State

Create a lamp to display the ON/OFF state of the Bit Address that monitors the device/PLC's communication state.

- 1 Select the [Part (P)] menu - [Switch Lamp] option - [Lamp] command or click  to place a lamp on the screen.
- 2 Double-click the placed lamp and the setting dialog box will be displayed.

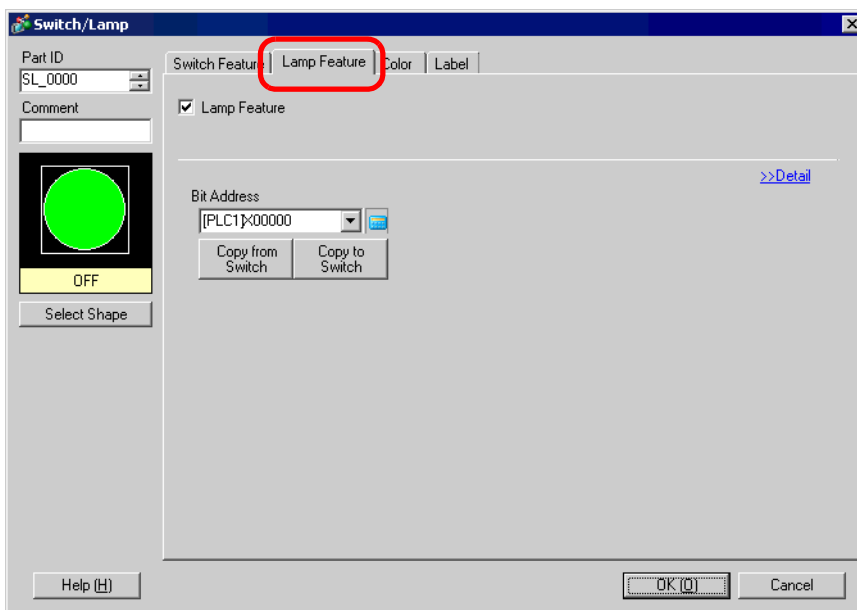

- 3 Select the lamp shape in [Select Shape].

- 4 Set the bit address to turn ON/OFF the lamp (e.g.: LS956000) to the [Bit Address].

Click on the icon and an address input keypad is displayed.

Select [#INTERNAL] for the [Device/PLC] and "LS" for the Device, input "956000" in the address, and press the "Ent" key.

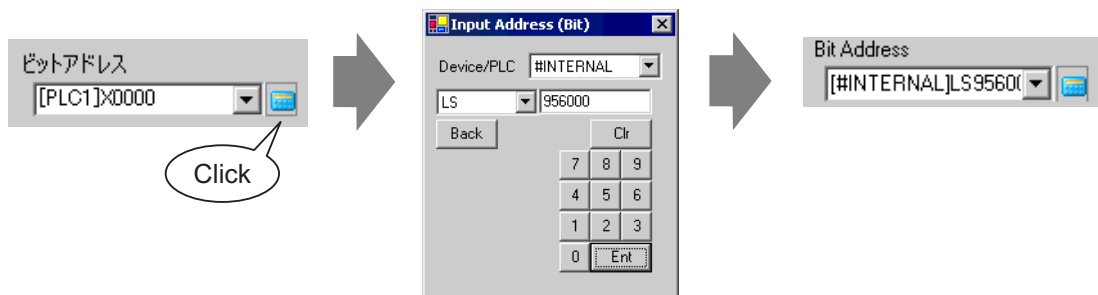

NOTE

- The setting range of the bit addresses to monitor the device/PLC's communication state is the internal device address' LS9560 to LS9567. Each device/PLC address starting from Bit 0 is assigned sequentially to each driver's device/PLC starting from the first unit.

LS Area

LS9560	Driver 1's Machine 1 to 16
LS9561	Driver 1's Machine 17 to 32
LS9562	Driver 2's Machine 1 to 16
LS9563	Driver 2's Machine 17 to 32
LS9564	Driver 3's Machine 1 to 16
LS9565	Driver 3's Machine 17 to 32
LS9566	Driver 4's Machine 1 to 16
LS9567	Driver 4's Machine 17 to 32
LS9568	Reserved
LS9569	Reserved

e.g.)

You can set the bit addresses controlling the communication scan of the Driver 1's first to 16th units to LS9560.

[LS9560]

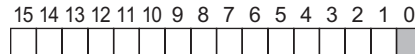

Bit 0: Turns ON when the Driver 1's first unit is in the communication state and turns OFF when it is disconnected.

You can confirm that the Driver 1's first unit is in the communication state with Bit 0 turning ON. Bit 0 turns OFF when the device/PLC is disconnected.

- Click the [Color] tab and set the Lamp's display colors. Set a [Display Color], [Pattern] and [Border Color] for each case where the [Select State] is ON or OFF.

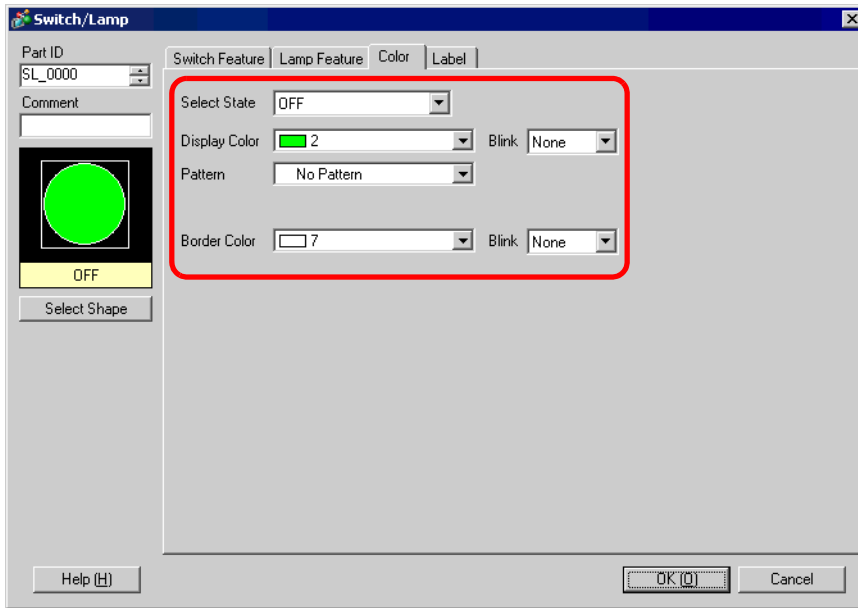

- Click the [Label] tab and set the label displayed at the top of the lamp parts. Specify its font and size, input display text into the rectangle field, and click [OK].

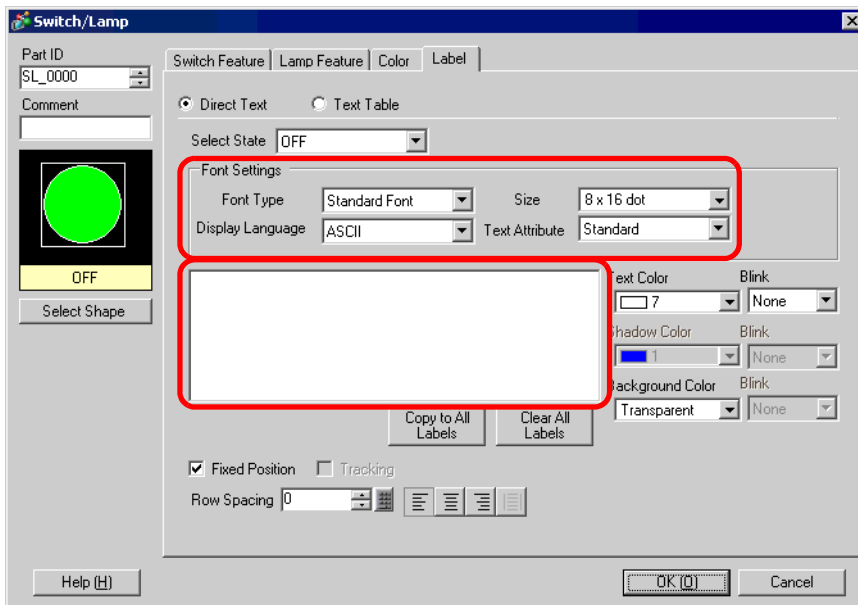

7.4 Changing a Device/PLC

7.4.1 Details

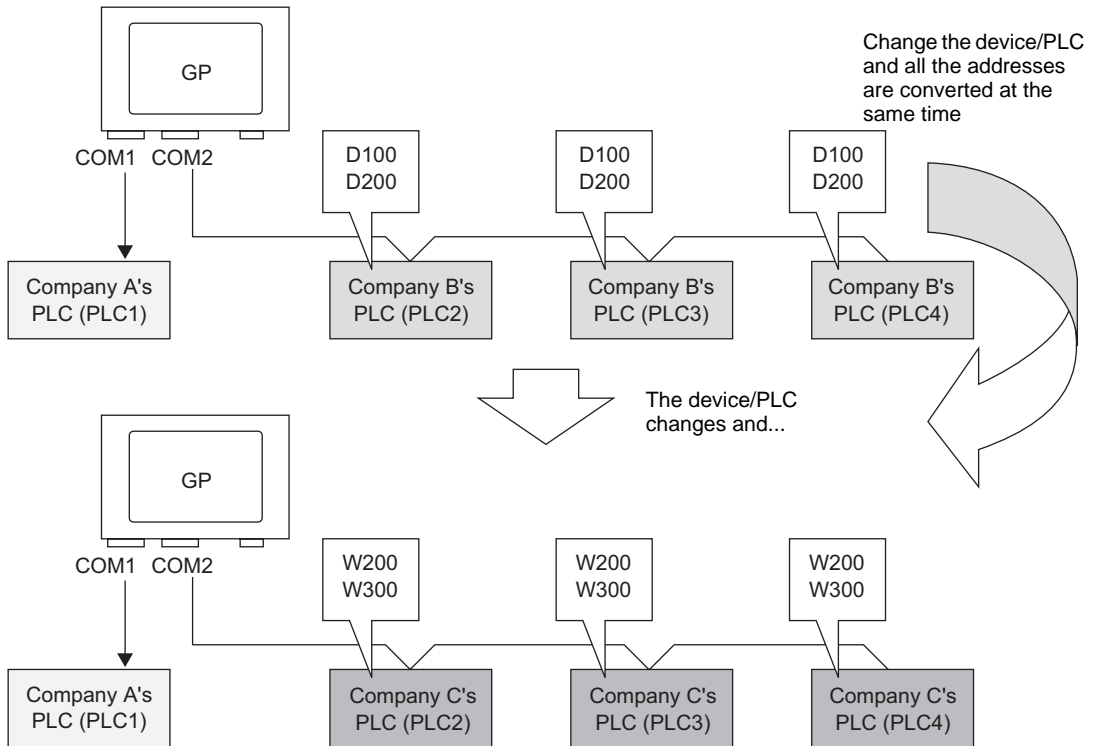

When changing the type of PLC, addresses can be modified for multiple PLCs at the same time.

There are two methods for converting addresses when changing a device/PLC model: Converting the PLC type without designating an Address Conversion Range, or Designating an Address Conversion Range and Converting the PLC type.

7.4.2 Setup Procedure

■ Converting the PLC type without designating an Address Conversion Range

Change the type of device without specifying an address conversion pattern at the time of conversion.

- NOTE** • Please refer to the settings guide for details.
 ☞ "7.5.1 [Change Device/PLC] Settings Guide" (page 7-28)

e.g.) COM1: Company A's PLC, PLC1 (e.g.: Omron, CS/CJ Series HOST Link)
 COM2: Company B's PLCs, PLC2, PLC3, PLC4
 (e.g.: Mitsubishi, A Series Computer Link)

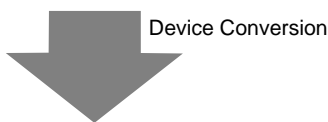

COM1: Company A's PLC, PLC1 (e.g.: Omron, CS/CJ Series HOST Link)
 COM2: Company C's PLCs, (e.g.: Yokogawa Electric Corp., Computer Link SIO)

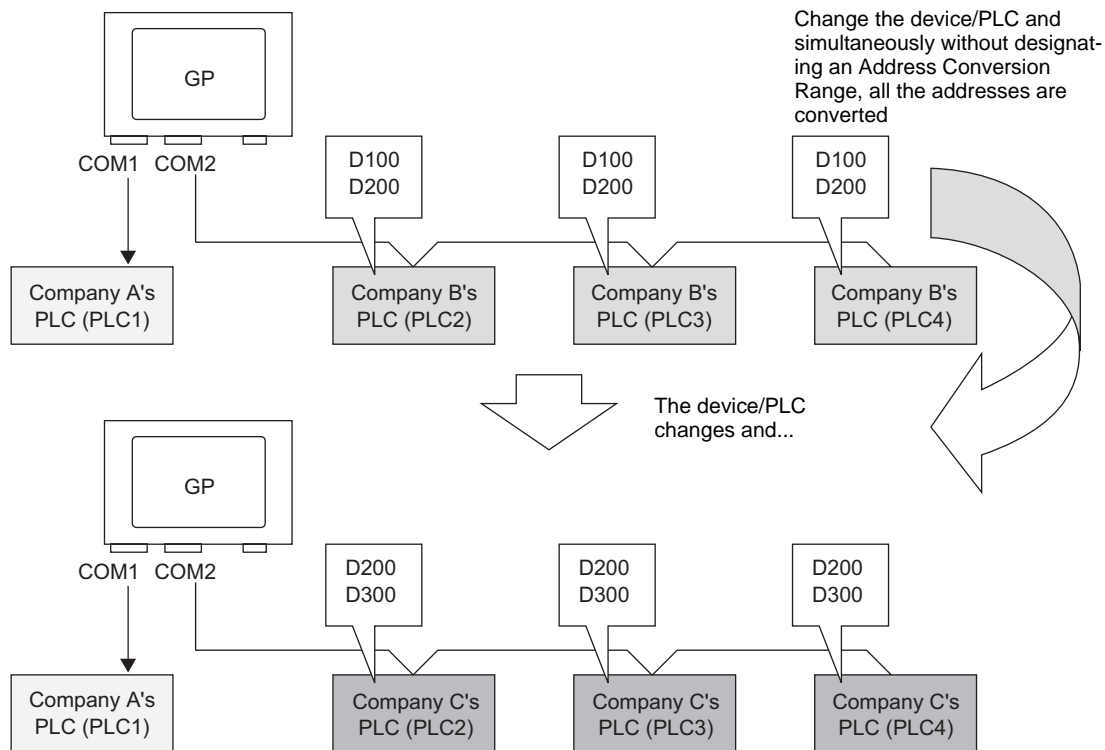

- NOTE** • If there is no Convert Destination device code, the address may not display correctly. After converting a device/PLC, please reconfirm all device addresses used in the project and correct the relevant addresses.

- 1 Select the [Project (F)] menu - [System Settings (C)] command, or click  and click the System Settings Window's [Device/PLC Settings]. The following [Device/PLC Settings] screen will appear.

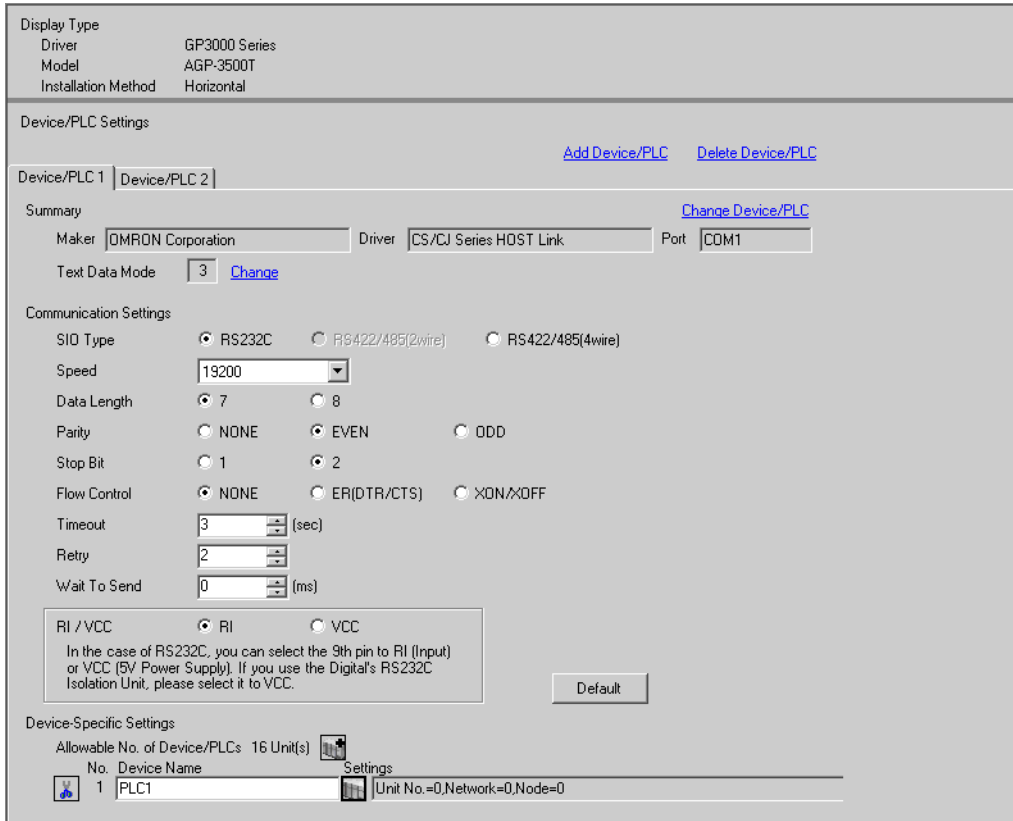

Display Type
Driver GP3000 Series
Model AGP-3500T
Installation Method Horizontal

Device/PLC Settings [Add Device/PLC](#) [Delete Device/PLC](#)

Device/PLC 1 | **Device/PLC 2**

Summary [Change Device/PLC](#)

Maker Driver Port

Text Data Mode [Change](#)

Communication Settings

SIO Type RS232C RS422/485(2wire) RS422/485(4wire)

Speed

Data Length 7 8

Parity NONE EVEN ODD

Stop Bit 1 2

Flow Control NONE ER(DTR/CTS) XON/XOFF

Timeout (sec)



Retry

Wait To Send (ms)

RI / VCC RI VCC
In the case of RS232C, you can select the 9th pin to RI (Input) or VCC (5V Power Supply). If you use the Digital's RS232C Isolation Unit, please select it to VCC. [Default](#)

Device-Specific Settings

Allowable No. of Device/PLCs 16 Unit(s) 

No.	Device Name	Settings
 1	PLC1	 Unit No.=0,Network=0,Node=0

- 2 Click the [Device/PLC 2] tab, and click [Change Device/PLC].

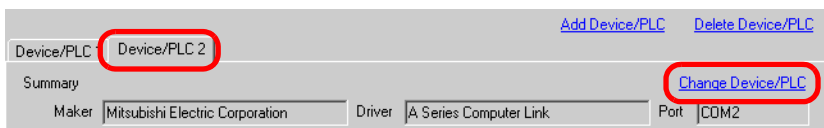

Device/PLC **Device/PLC 2** [Add Device/PLC](#) [Delete Device/PLC](#)

Summary [Change Device/PLC](#)

Maker Driver Port

- 3 When the following [Change Device/PLC] dialog box appears, set the [Maker] and [Driver] of the device/PLC you want to change to.

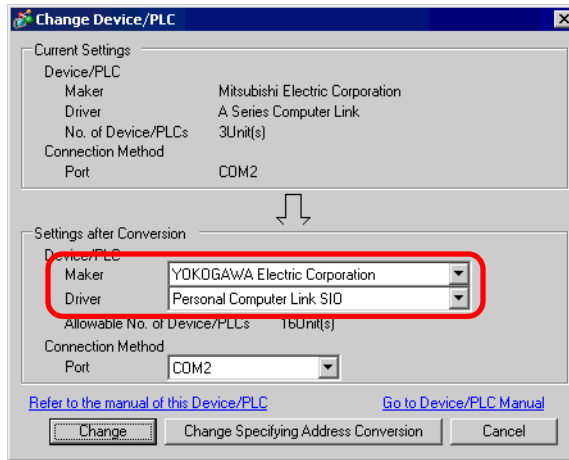

- 4 Click [Change].

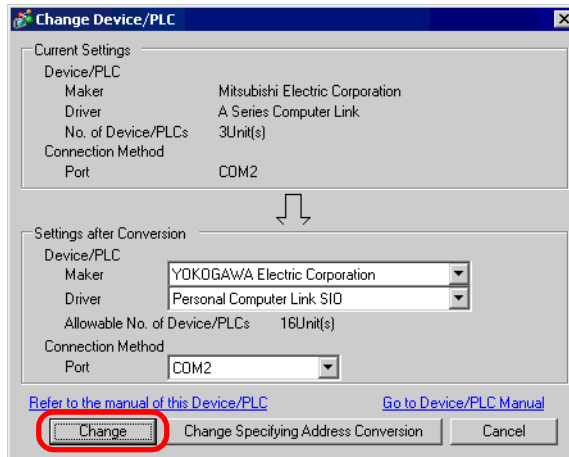

5 The following message will appear. Click [OK] and the settings are complete.

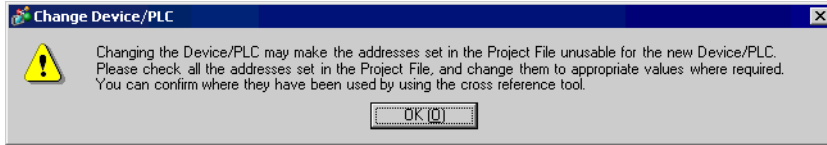

NOTE

- If you change the device/PLC by clicking the [Change] button in the [Change Device/PLC] dialog box, the address conversion pattern may not display correctly if there is no device code at the destination. Please reconfirm all device addresses used in the project and correct the relevant addresses.
 - After converting a device/PLC, any parts, D-Scripts, Alarms, etc., must have their device addresses set again. Also, please save any screens that use a Special Switch set to [Screen Change].
 - If using a Ethernet communication driver when converting multiple device/PLCs, [UDP] and [TCP] cannot be set up in the same driver.
e.g.) When [Device/PLC 1] has been set to MELSEC A Ethernet [UDP] type, [Device/PLC 2] cannot be set to MELSEC A Ethernet [TCP] type.
-

■ Designating an Address Conversion Range and Converting the PLC type

Change the type of device by specifying an address conversion pattern at conversion time. Designate the previous address' range and the top address of the destination device/PLC.

NOTE

- Please refer to the settings guide for details.
 - ☞ "7.5.1 [Change Device/PLC] Settings Guide" (page 7-28)
 - ☞ "7.5.2 [Address Conversion Method Specification] Settings Guide" (page 7-29)

e.g.) COM1: Company A's PLC, PLC1 (e.g.: Omron, CS/CJ Series HOST Link)
 COM2: Company B's PLCs, PLC2, PLC3, PLC4
 (e.g.: Mitsubishi, A Series Computer Link)

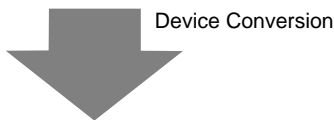

COM1: Company A's PLC, PLC1 (e.g.: Omron, CS/CJ Series HOST Link)
 COM2: Company C's PLCs, (e.g.: Yokogawa Electric Corp., Computer Link SIO)

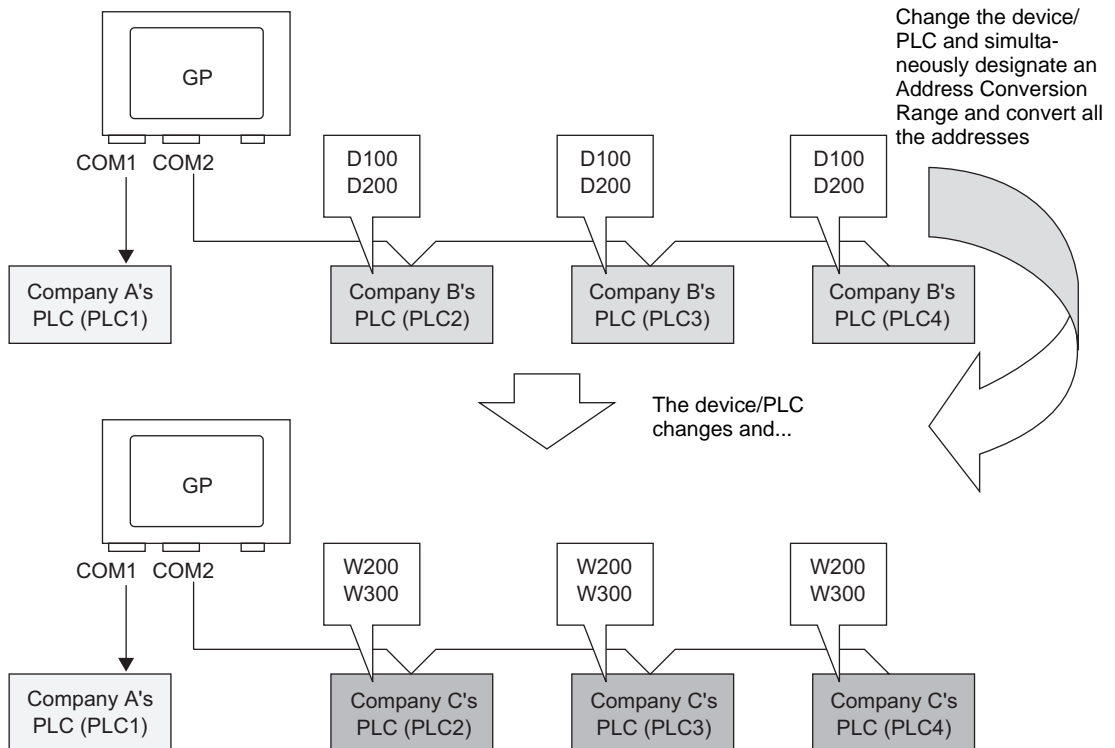

1 Select the [Project (F)] menu - [System Settings (C)] command, or click  and click the System Settings Window's [Device/PLC Settings]. The following [Device/PLC Settings] screen will appear.

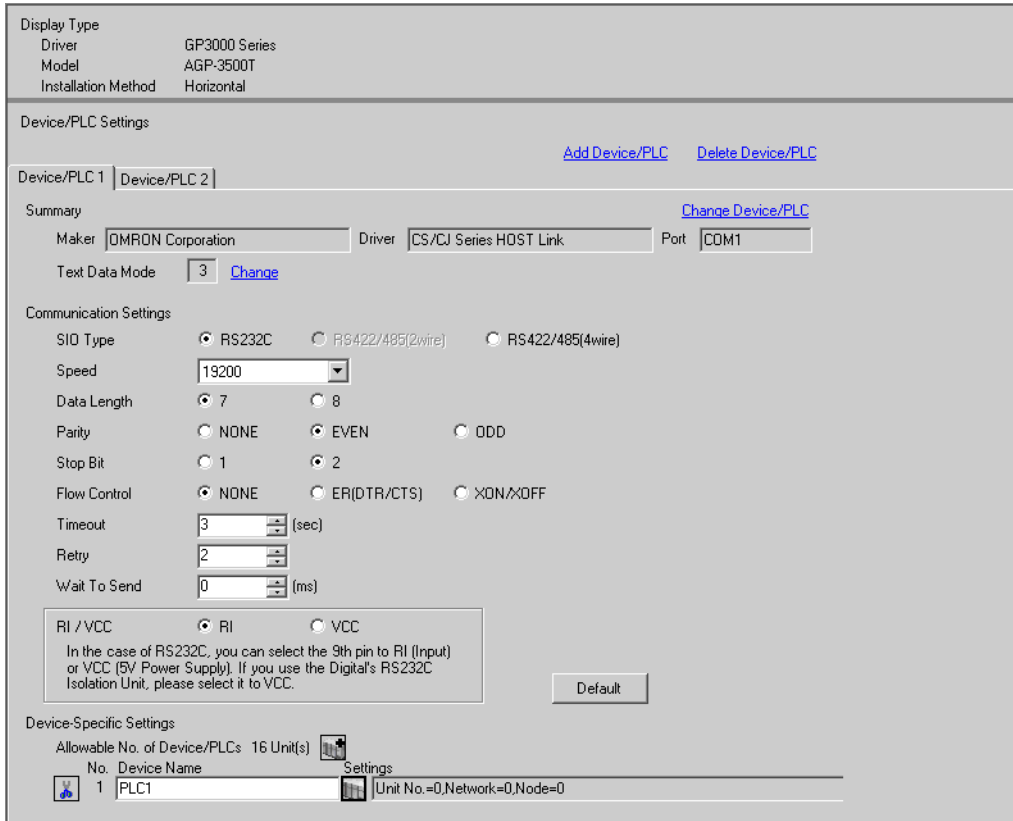

Display Type
Driver GP3000 Series
Model AGP-3500T
Installation Method Horizontal

Device/PLC Settings

[Add Device/PLC](#) [Delete Device/PLC](#)

Device/PLC 1 | **Device/PLC 2**

Summary [Change Device/PLC](#)

Maker Driver Port

Text Data Mode [Change](#)

Communication Settings

SI0 Type RS232C RS422/485(2wire) RS422/485(4wire)

Speed

Data Length 7 8

Parity NONE EVEN ODD

Stop Bit 1 2

Flow Control NONE ER(DTR/CTS) XON/XOFF

Timeout (sec)

Retry

Wait To Send (ms)

RI / VCC RI VCC

In the case of RS232C, you can select the 9th pin to RI (Input) or VCC (5V Power Supply). If you use the Digital's RS232C Isolation Unit, please select it to VCC.

Device-Specific Settings

Allowable No. of Device/PLCs 16 Unit(s)

No. Device Name Settings

2 Click the [Device/PLC 2] tab, and click [Change Device/PLC].

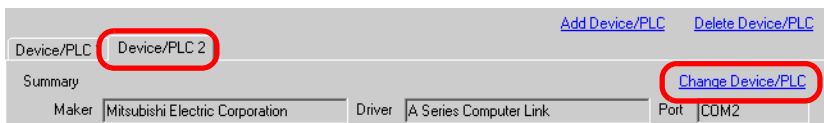

[Add Device/PLC](#) [Delete Device/PLC](#)

Device/PLC | **Device/PLC 2**

Summary [Change Device/PLC](#)

Maker Driver Port

- 3 When the following [Change Device/PLC] dialog box appears, set the [Maker] and [Driver] of the device/PLC you want to change to.

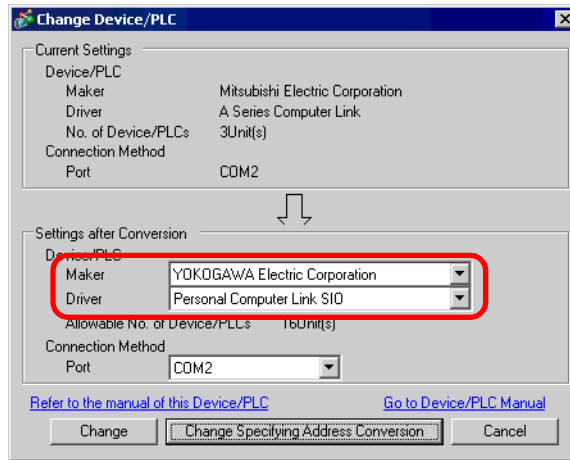

- 4 Click [Change Specifying Address Conversion].

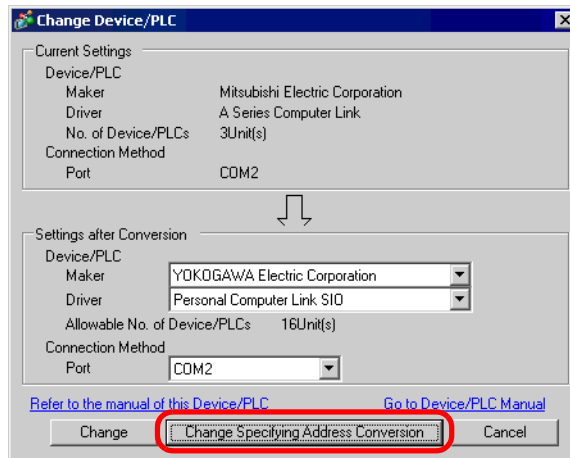

5 When the [Address Conversion Method Specification] dialog box appears, click [Add].

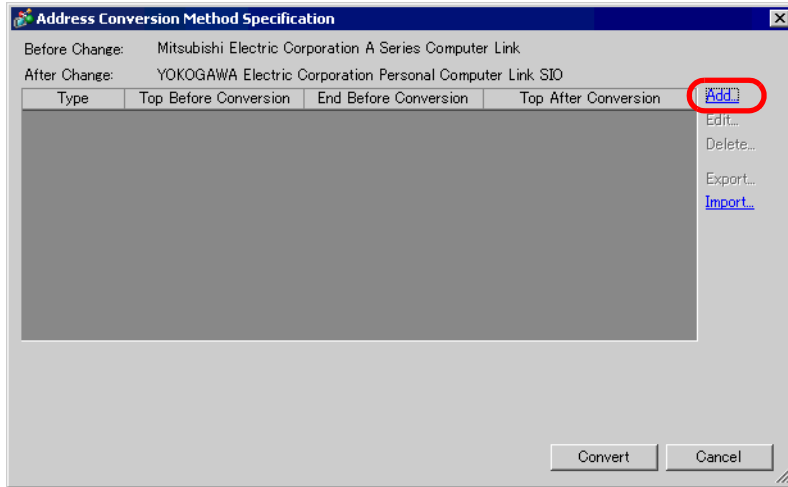

6 When the [Register Address Conversion Pattern] dialog box appears, set the [Address Type], the Before Conversion [Top] and [End] address, and the After Conversion [Top] address.

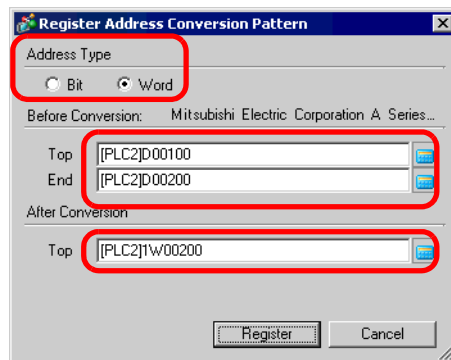

7 Click [Register].

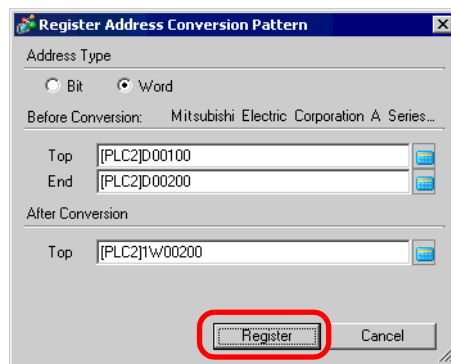

- 8 When the [Address Conversion Method Specification] dialog box appears and the conversion pattern is added, click [Convert].

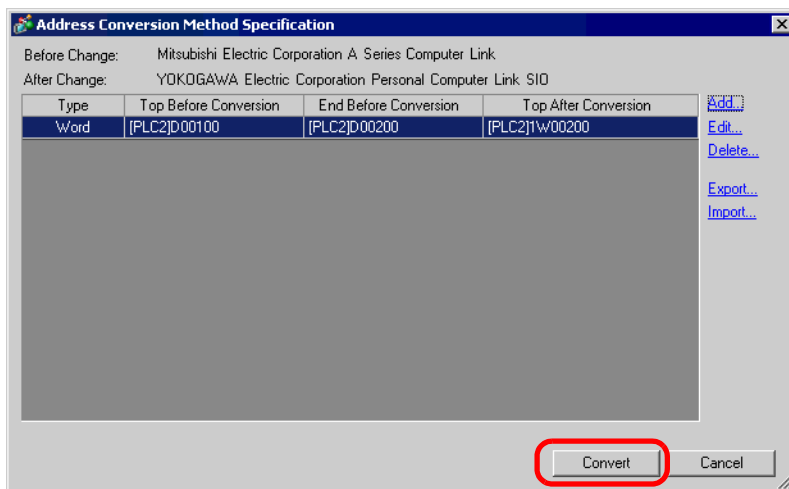

NOTE

- After converting a device/PLC, any parts, D-Scripts, Alarms, etc., must have their device addresses set again. Also, please save any screens that use a Special Switch set to [Screen Change].
- If using a Ethernet communication driver when converting multiple device/PLCs, [UDP] and [TCP] cannot be set up in the same driver.
 e.g.) When [Device/PLC 1] has been set to MELSEC A Ethernet [UDP] type, [Device/PLC 2] cannot be set to MELSEC A Ethernet [TCP] type.

7.5 Settings Guide

7.5.1 [Change Device/PLC] Settings Guide

On the [Device/PLC Settings] screen, click on [Change Device/PLC] and the following dialog box will be displayed. Select the model of device/PLC you want to change to.

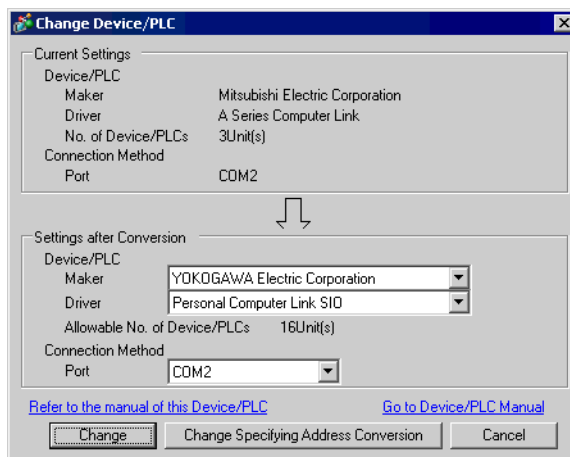

Setting		Description
Current Settings	Maker	Displays the maker of the currently set device/PLC.
	Driver	Displays the series of the currently set PLC.
	No. of Device/PLCs	Displays the number of connected devices for the currently set PLC.
	Port	Displays the connection port of the currently set PLC.
Settings after Conversion	Maker	Sets the maker of the new PLC.
	Driver	Sets the series of the new PLC.
	Allowable No. of Device/PLCs	Displays the number of devices that can be connected with the new PLC.
	Port	Select a connection port for the new PLC from [COM1], [COM2], [Ethernet (UDP)], or [Ethernet (TCP)].
Refer to the manual of this Device/PLC		Displays the page that mentions the new device/PLCs model in the "GP-Pro EX Device/PLC Connection Manual".
Go to Device/PLC Manual		Displays the top page of the "GP-Pro EX Device/PLC Connection Manual".
Change		Changes the model of device without specifying an address conversion pattern. NOTE <ul style="list-style-type: none"> Because no address conversion pattern is specified, if there is no destination address code, the address may not display correctly.
Change Specifying Address Conversion		Changes the model of device by specifying an address conversion pattern. Designate the previous address' range and the top address of the destination device/PLC.
Cancel		Cancels the settings of the new device/PLC.

7.5.2 [Address Conversion Method Specification] Settings Guide

On the [Change Device/PLC] dialog box, click [Change Specifying Address Conversion] and the following dialog box appears. You can specify an Address Conversion Range when changing device/PLC models.

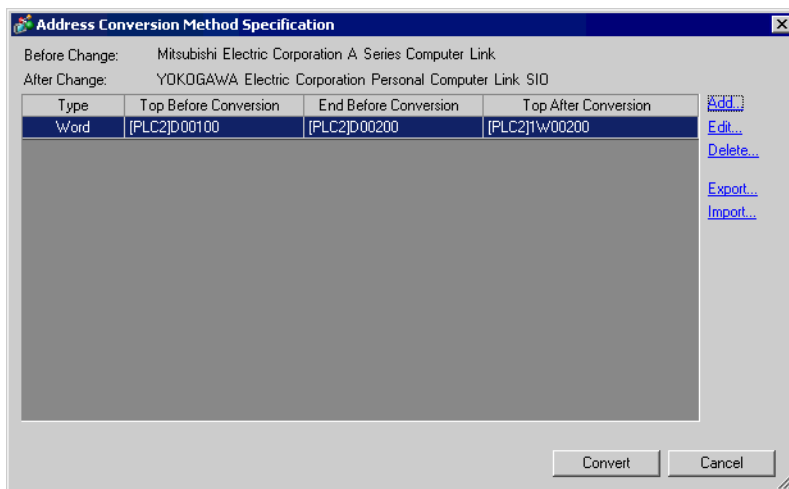

Setting	Description
Before Change	Displays the PLC maker and series of the original PLC.
After Change	Displays the PLC maker and series of the new PLC.
Type	Displays [Word] or [Bit], depending on which is the conversion address type.
Top Before Conversion	Displays the start value of the device address used before the address conversion.
End Before Conversion	Displays the end value of the device address used before the address conversion.
Top After Conversion	Displays the start value of the device address used after the address conversion.
Add/Edit	Add/edit new settings for an address conversion pattern. The following dialog box will appear. <div data-bbox="578 1277 1029 1638" data-label="Image"> </div>
Address Type	Choose conversion address' type from [Bit] or [Word].
Before Conversion	Displays the PLC maker and series of the original PLC.
Top	Set the source PLC and the start address.

Continued

Setting		Description
Add/Edit	End	Set the source PLC and the end address.
	After Conversion	Displays the PLC maker and series of the new PLC.
	Top	Set the destination PLC and the start address.
Delete		Delete the address conversion pattern.
Export/Import		<p>Read (Import) or output (Export) the contents of an Address Conversion Pattern.</p> <div style="text-align: center;"> </div> <p>(1) Import You can use a previously saved file in CSV format to create an address conversion pattern file (see (2)). Address conversion pattern files can be used in a different project by importing them.</p> <div style="text-align: center;"> </div> <p>• Click on [Import] and the following [Open File] dialog box will appear. Set the [Look in], [File name], click [Open] and the file will be imported.</p> <div style="text-align: center;"> </div> <p>NOTE</p> <ul style="list-style-type: none"> When importing a CSV file, make sure it matches the address conversion pattern's format. If the formats do not match, the file will not be successfully imported.

Continued

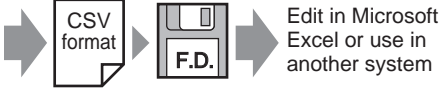
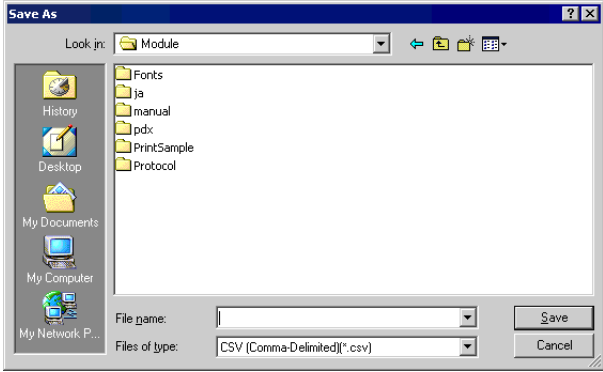
Setting	Description												
<p>Export/Import</p>	<p>(2) Export</p> <p>You can export registered address conversion patterns to outside media by saving them in CSV format. The saved file can then be edited in Microsoft Excel or other spreadsheet software.</p> <div style="text-align: center;"> <table border="1" data-bbox="465 365 698 533"> <thead> <tr> <th>Top Before Conversion</th> <th>End Before Conversion</th> <th>Top After Conversion</th> </tr> </thead> <tbody> <tr> <td>D100</td> <td>D200</td> <td>W100</td> </tr> <tr> <td>D300</td> <td>D400</td> <td>W300</td> </tr> <tr> <td>⋮</td> <td>⋮</td> <td>⋮</td> </tr> </tbody> </table>  </div> <ul style="list-style-type: none"> • Click on [Export] and the following [Save As] dialog box will appear. Set the [Look in], [File name], click [Save] and the file will be exported. <div style="text-align: center;">  </div> <p>NOTE</p> <ul style="list-style-type: none"> • This setting can be used when there are multiple address conversion patterns. • The exported CSV file can be edited in a spreadsheet program such as Microsoft Excel. 	Top Before Conversion	End Before Conversion	Top After Conversion	D100	D200	W100	D300	D400	W300	⋮	⋮	⋮
Top Before Conversion	End Before Conversion	Top After Conversion											
D100	D200	W100											
D300	D400	W300											
⋮	⋮	⋮											

Continued

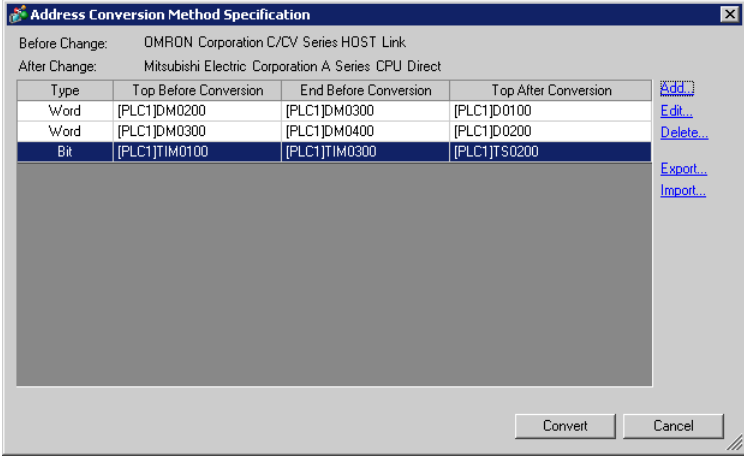
Setting	Description																														
<p>Export/Import</p>	<ul style="list-style-type: none"> • Sample Output to a CSV File Export data's CSV format will be displayed as follows. Address conversion patterns before export  <p>The CSV file created by exporting the above file</p> <pre> Pattern List Key Name *1 OMR_CSIO Convert-From driver MIT_ACPU Convert-To driver 0,[PLC1]DM0200,[PLC1]DM0300,[PLC1]D0100..... [Type] *2, [Device/PLC Name] Convert-From Top Address, [Device/PLC Name] Convert-From End Address, [Device/PLC Name] Convert-To Top Address 0,[PLC1]DM0300,[PLC1]DM0400,[PLC1]D0200..... [Type] *2, [Device/PLC Name] Convert-From Top Address, [Device/PLC Name] Convert-From End Address, [Device/PLC Name] Convert-To Top Address 1,[PLC1]TIM0100,[PLC1]TIM0300,[PLC1]TS0200..... [Type] *2, [Device/PLC Name] Convert-From Top Address, [Device/PLC Name] Convert-From End Address, [Device/PLC Name] Convert-To Top Address </pre> <p>When the above CSV file is represented in tabular format, it looks as follows.</p> <table border="1" data-bbox="375 1379 1133 1588"> <thead> <tr> <th>Pattern List</th> <th></th> <th></th> <th></th> <th></th> </tr> </thead> <tbody> <tr> <td><u>OMR_CSIO</u></td> <td></td> <td></td> <td></td> <td></td> </tr> <tr> <td><u>MIT_ACPU</u></td> <td></td> <td></td> <td></td> <td></td> </tr> <tr> <td></td> <td>0</td> <td>[PLC1]DM0200</td> <td>[PLC1]DM0300</td> <td>[PLC1]D0100</td> </tr> <tr> <td></td> <td>0</td> <td>[PLC1]DM0300</td> <td>[PLC1]DM0400</td> <td>[PLC1]D0200</td> </tr> <tr> <td></td> <td>1</td> <td>[PLC1]TIM0100</td> <td>[PLC1]TIM0300</td> <td>[PLC1]TS0200</td> </tr> </tbody> </table> <p>Annotations for the table above:</p> <ul style="list-style-type: none"> Convert-From driver (points to OMR_CSIO) Convert-To driver (points to MIT_ACPU) Type (points to the first column) Device/PLC Name (points to the second column) Convert-From Top Address (points to the third column) Convert-From End Address (points to the fourth column) Convert-To Top Address (points to the fifth column) <p>*1 This is the special text used to identify the address conversion pattern's CSV file.</p> <p>*2 [Word Address]: 0, [Bit Address]: 1</p>	Pattern List					<u>OMR_CSIO</u>					<u>MIT_ACPU</u>						0	[PLC1]DM0200	[PLC1]DM0300	[PLC1]D0100		0	[PLC1]DM0300	[PLC1]DM0400	[PLC1]D0200		1	[PLC1]TIM0100	[PLC1]TIM0300	[PLC1]TS0200
Pattern List																															
<u>OMR_CSIO</u>																															
<u>MIT_ACPU</u>																															
	0	[PLC1]DM0200	[PLC1]DM0300	[PLC1]D0100																											
	0	[PLC1]DM0300	[PLC1]DM0400	[PLC1]D0200																											
	1	[PLC1]TIM0100	[PLC1]TIM0300	[PLC1]TS0200																											

7.6 Restrictions

- After converting a device/PLC, any parts, D-Scripts, Alarms, etc., must have their device addresses set again. Also, please save any screens that use a Special Switch set to [Screen Change].
 - If you change the device/PLC by clicking the [Change] button in the [Change Device/PLC] dialog box, the address conversion pattern may not display correctly if there is no device code at the destination. Please reconfirm all device addresses used in the project and correct the relevant addresses.
 - When using a Ethernet communication driver with multiple connections, [UDP] or [TCP] can not be set up in the same driver.
e.g.) When [Device/PLC 1] has been set to MELSEC A Ethernet [UDP] type, [Device/PLC 2] can not be set to MELSEC A Ethernet [TCP] type.
 - When deleting the settings for multiple connected PLCs, connected devices whose addresses are already used inside a project can not be deleted. If you can not delete PLC settings, click [Project] menu - [Utility] command and open [Cross Reference]. You can then check which addresses are being used. Next, delete the PLC settings after either replacing the address in use or deleting the unused address.
 - You cannot stop the communication scan of a device specified with the System Area Start Address. However, if you are not using the System Data Area, you can stop the communication scan.
-  "6.13.6 [System Settings Window] Setting Guide ◆ System Area Settings" (page 6-110)

Memo