

8 | Barcode Settings

This chapter explains about “Barcode Settings” in GP-Pro EX, and the basic operations used to change them.

Please start by reading “8.1 Settings Menu” (page 8-2) and then turn to the corresponding page.

8.1	Settings Menu	8-2
8.2	Connecting a Barcode/Two-dimensional Code Reader	8-4
8.3	Structure	8-19
8.4	Settings Guide.....	8-22
8.5	Restrictions	8-28

8.1 Settings Menu

Barcode readers are one of the widespread ID systems for books, CDs, information devices, etc. You can use a barcode reader with the COM1 or USB interface supplied with the GP series main unit.

NOTE

- You can connect one barcode reader to the COM1 port and one to the USB port, but when connecting two barcode readers at the same time and storing the code data in the Data Display parts or the internal device from both barcodes, the system may not work properly. Set the Data Display part to one barcode reader and the internal device to the other as a storage location.
-

Connecting a Barcode/Two-dimensional Code Reader

The code data read from a barcode/two-dimensional code reader can be stored in a device/PLC's device address through Data Display parts or can be stored in the GP's Internal Device address.

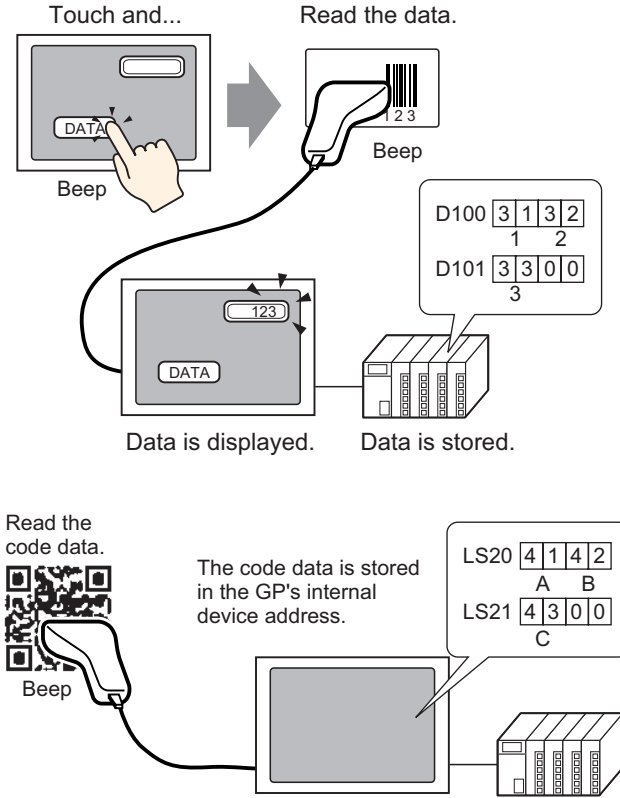

☞ Setup Procedure (page 8-5)

☞ Details (page 8-4)

8.2 Connecting a Barcode/Two-dimensional Code Reader

8.2.1 Details

The code data read from a barcode reader can be stored in a device/PLC's device address through Data Display parts or can be stored in the GP's internal device address.

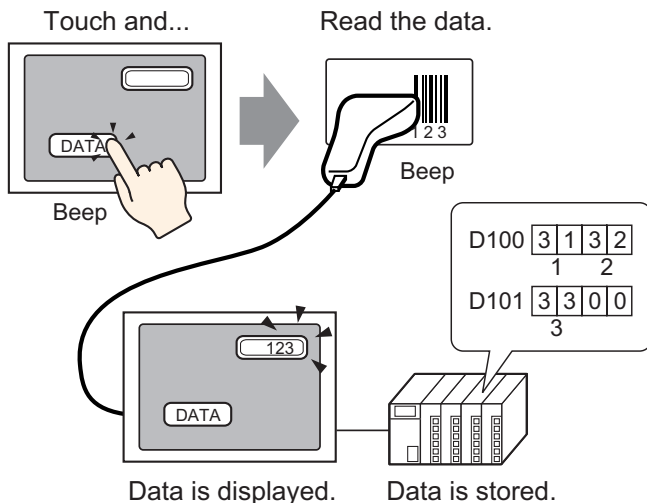

The code data read from a two-dimensional code reader can be stored in a device/PLC's device address through data display parts or can be stored in the GP's internal device address.

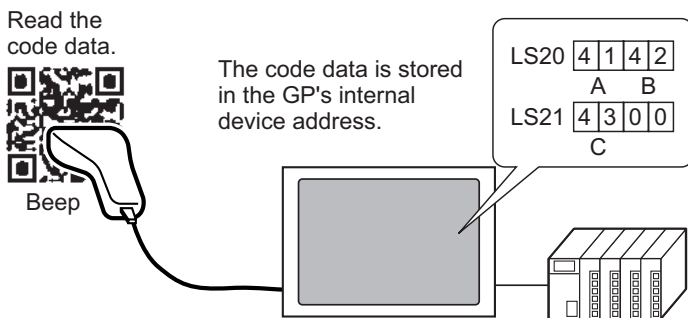



8.2.2 Setup Procedure

■ Barcode

- NOTE**
- For more details, refer to the settings guide.
 - ☞ “14.12 Data Display/Input Settings Guide” (page 14-51)
 - ☞ “8.4.1 [Bar Code Settings] Settings Guide” (page 8-22)

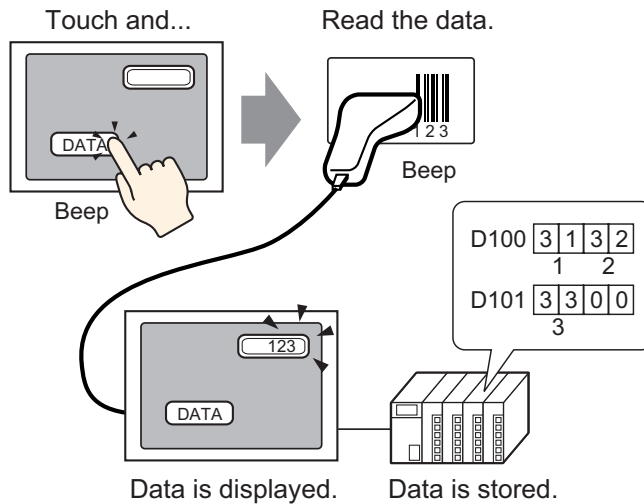
Configure settings to display the code data read from a barcode reader in Data Display parts and store it starting from the device/PLC’s D100 address.



1 Configure settings to communicate with the barcode. Select the [Project (F)] menu - [System Settings (C)] command, or click  and then the System Settings Window's [Bar Code Settings]. The following [Bar Code Settings] screen is displayed.

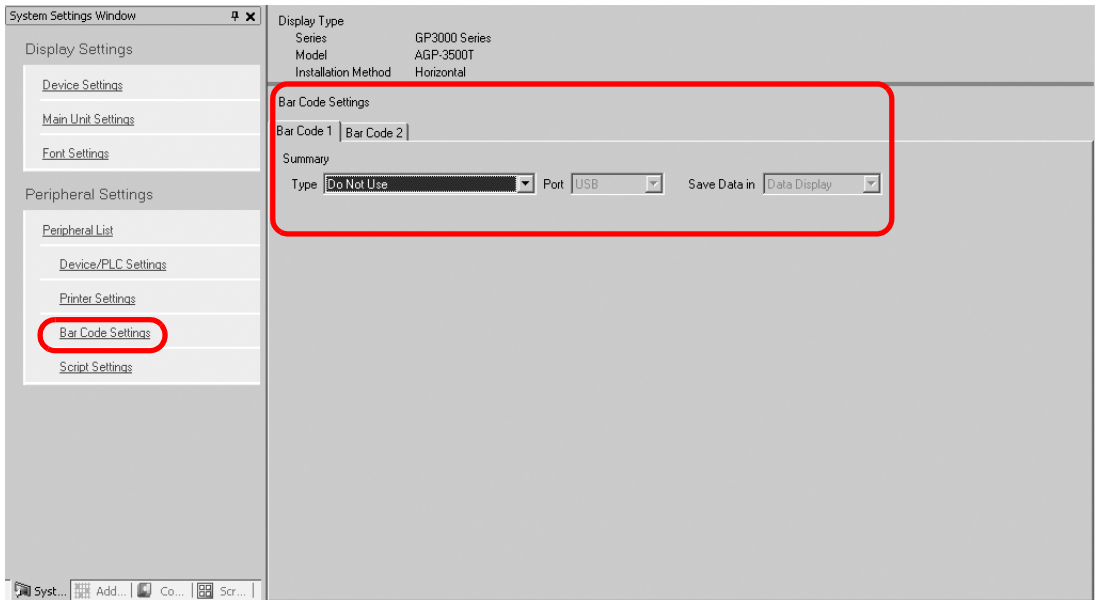

2 Select [Bar Code Reader] in [Type].

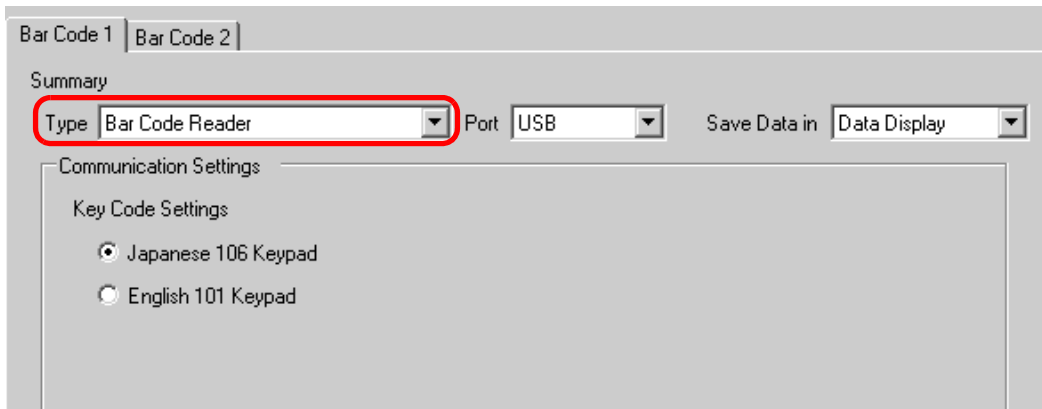

3 Select a port to connect to in [Port].

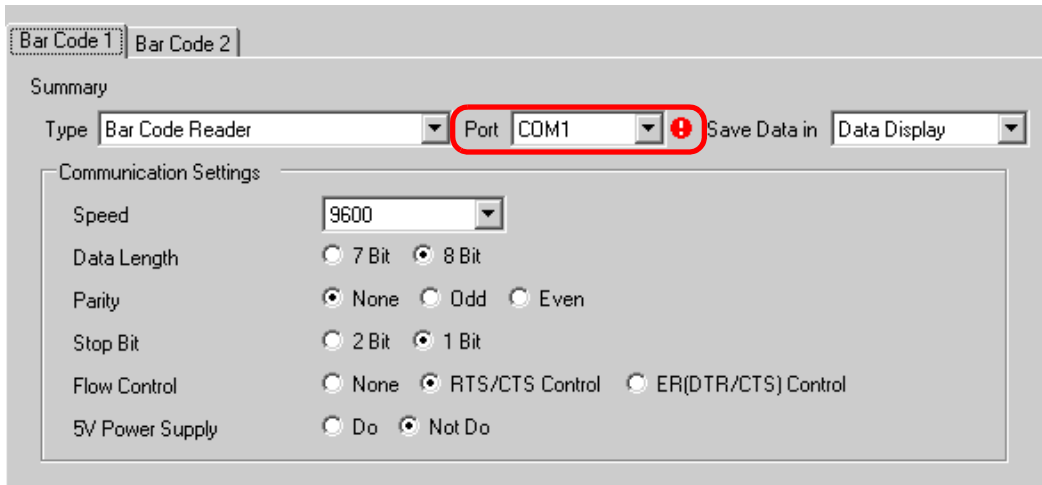

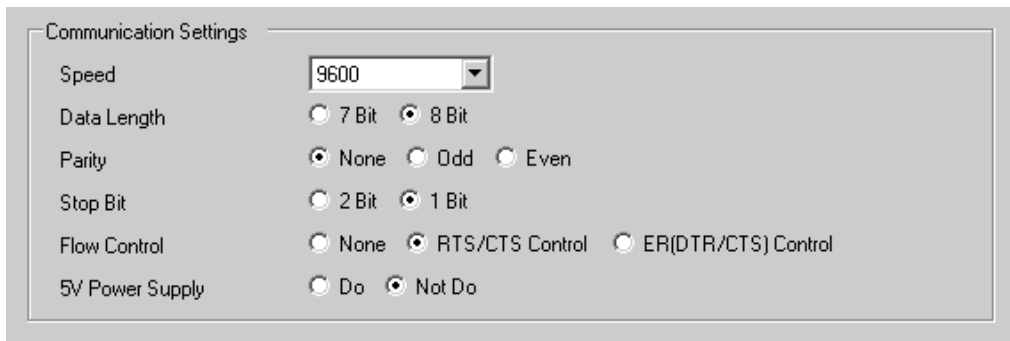

NOTE • If the port is also used for other devices/PLCs,  is displayed to the right of the [Port] as above.

4 In [Communication Settings], set [Speed], [Data Length], [Parity], [Stop Bit], [Flow Control] and [5V Power Supply].

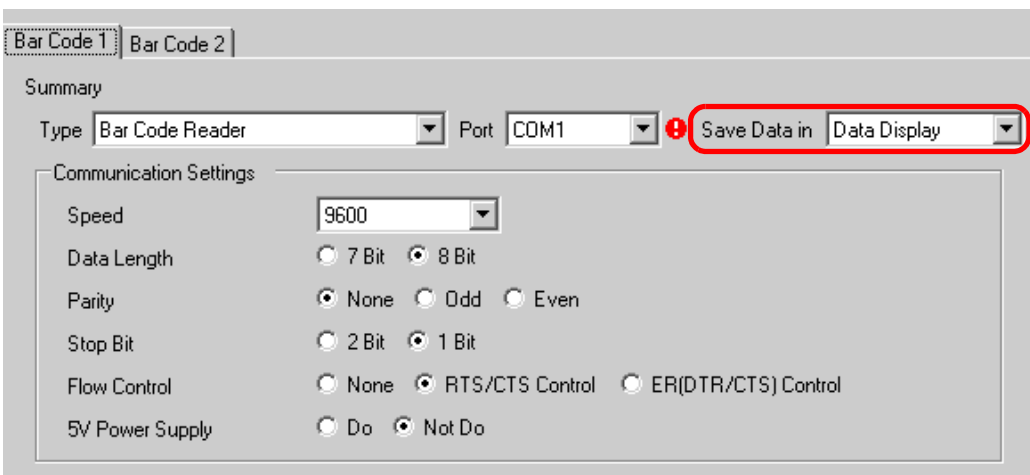

5 Select a data storage location in [Save Data in]. The settings to communicate with the barcode are complete.



6 Set the Data Display part to display the data read from the barcode. Click  to display the following editing screen.

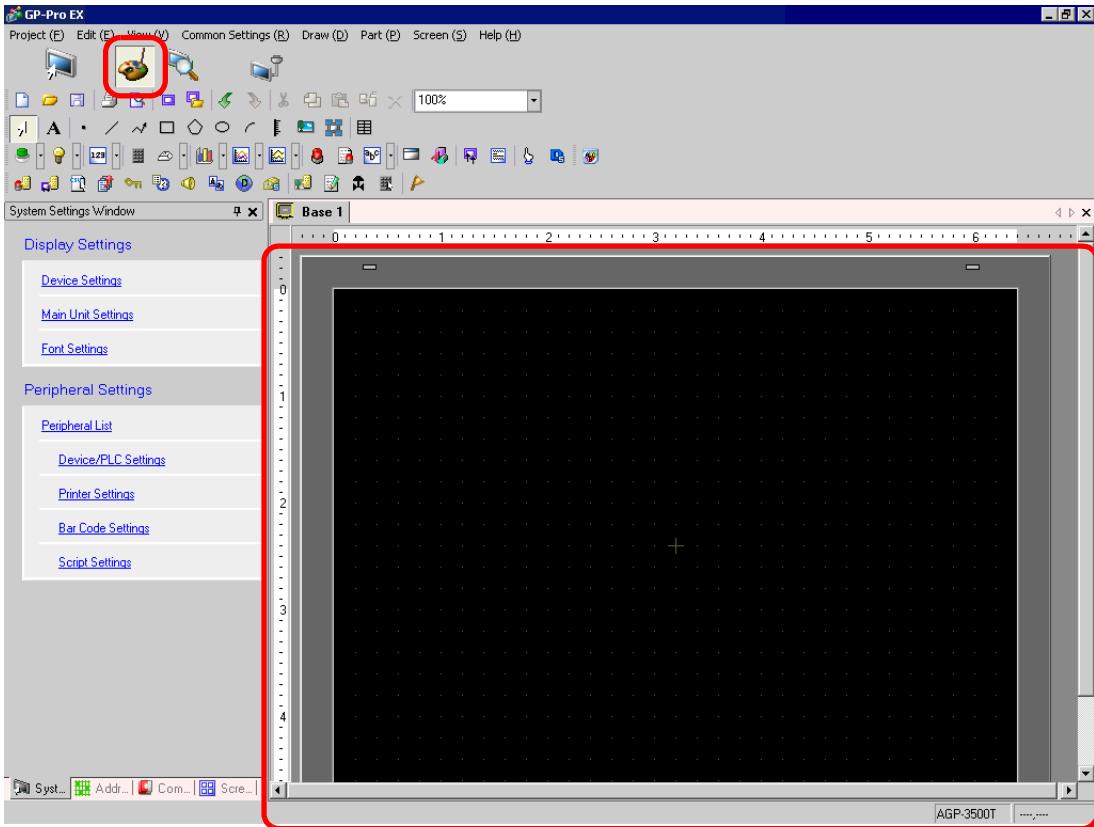

7 Select the [Part (P)] menu - [Data Display] option - [Text Display] command or click  to place a Data Display part on the screen.

8 Double-click the placed Data Display part and the setting dialog box will be displayed. Click [Text Display].

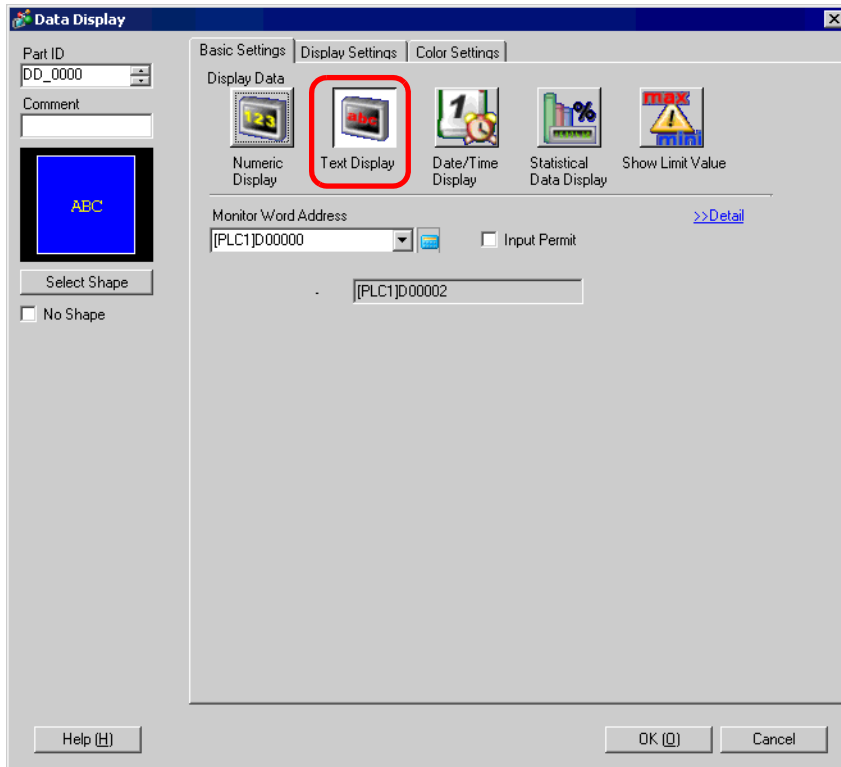

9 Select the Data Display part's shape in [Select Shape].

10 Click the [Display Settings] tab and set the [No. of Display Char.] from 1 to 100 for the number of single-byte characters. For two-byte characters, when the number of display characters is 2, it corresponds to one two-byte character. (e.g.: No. of single-byte characters "3")

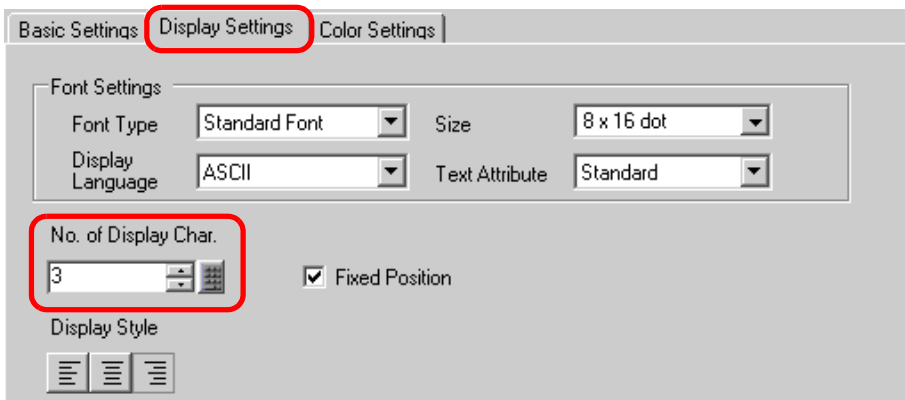

- Click the [Basic Settings] tab and set the address where the value read from a barcode reader is stored (e.g.: D100) in [Monitor Word Address].

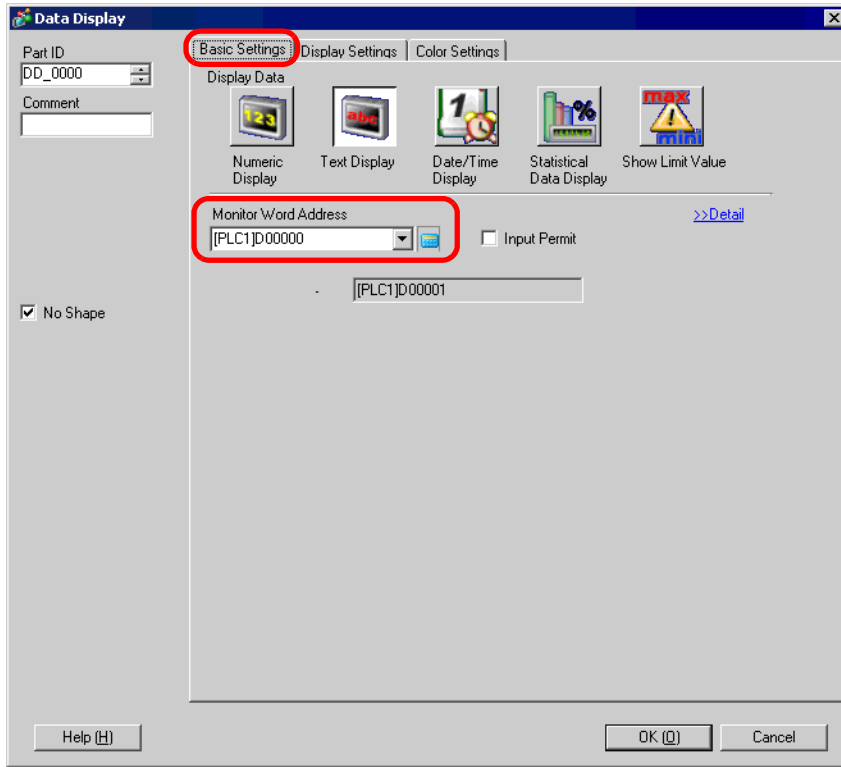

Click the icon to display an address input keypad.

Select the device "D", input "100" in the address, and press the "Ent" key.

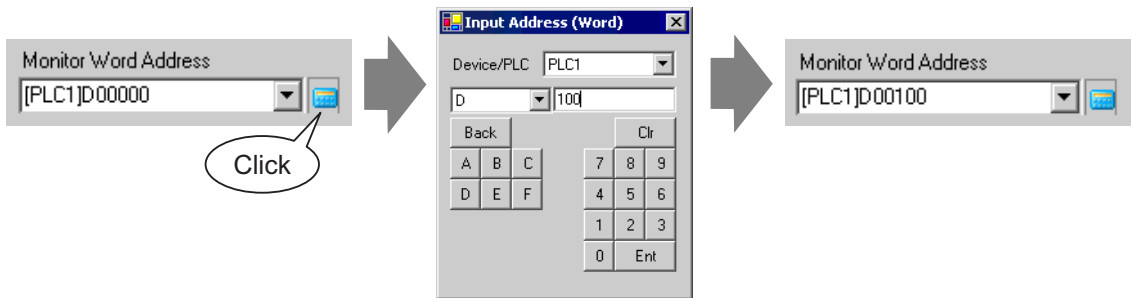

12 The address after the number of display characters used from the [Monitor Word Address] is displayed.

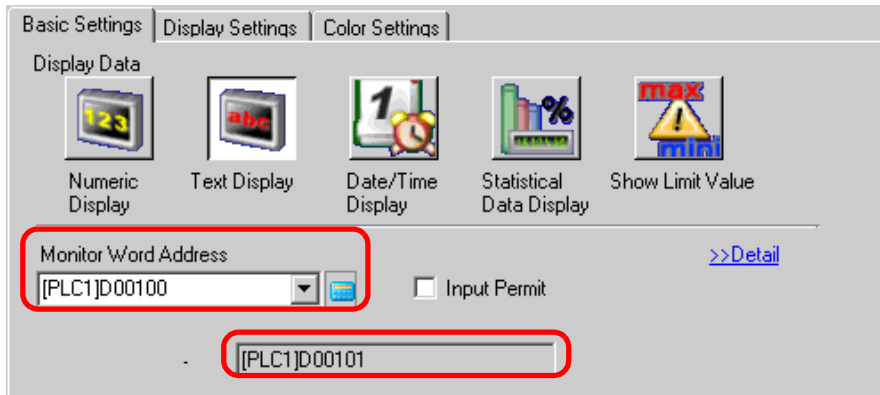

NOTE • One word is used for two single-byte alphanumeric characters or for one-byte character. In the above example, two words will be used because “3” single-byte characters are set to the [No. of Display Char.] in Step 10.

13 Put a check mark next to the [Input Permit] box. If [Input Permit] is checked, the [Input Permit] tab will be displayed for text data input.

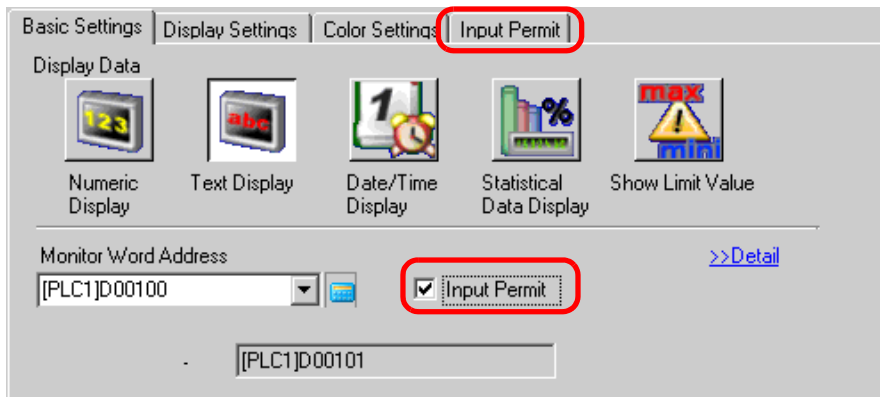

14 Click the [Input Permit] tab, select [Bit] for the input method, and click [Detail].

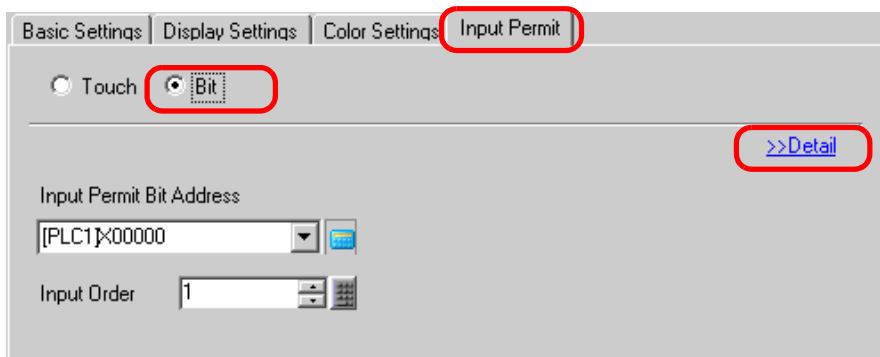

15 Put a check mark next to the [Input Barcode] box.

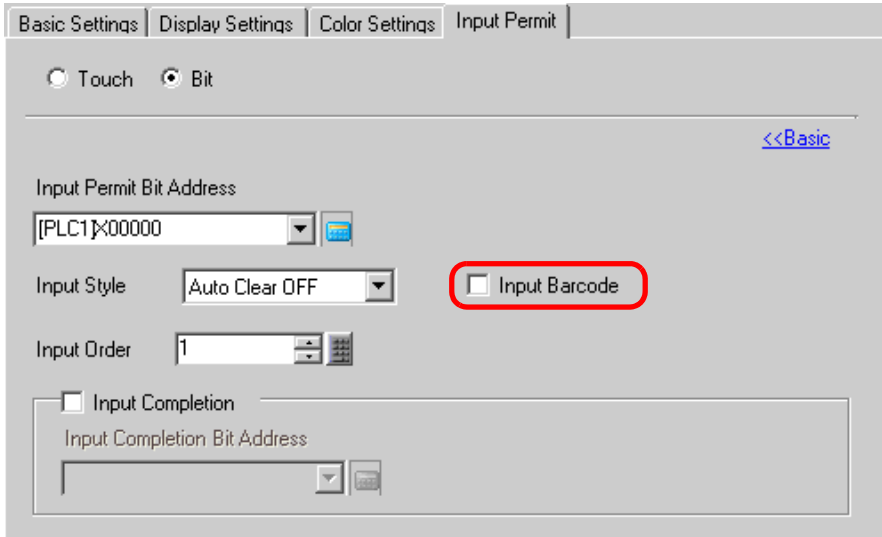

16 In [Input Style], select the processing method to overwrite the read code data.

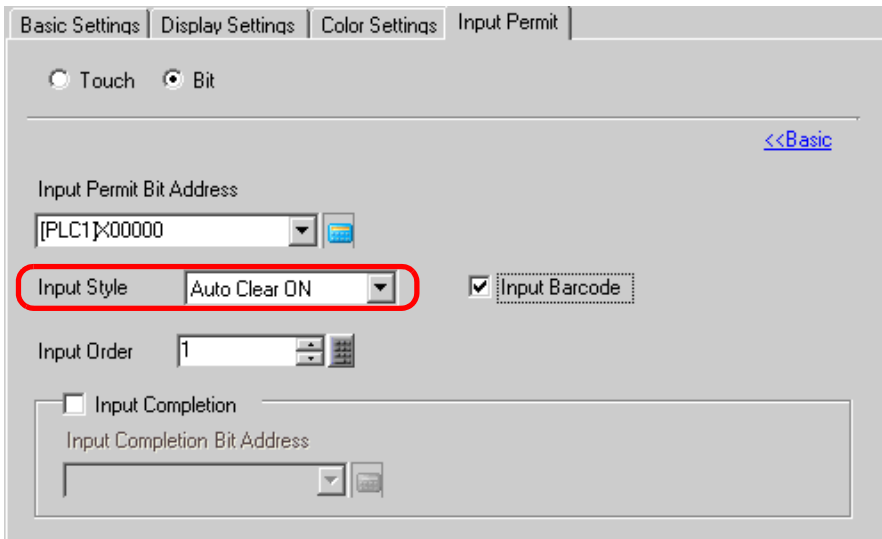

- 17 If necessary, set the Data Display part's color in the [Color Settings] tab or text in the [Display Settings] tab, and click [OK].

NOTE

- You have to set the bit switch to permit input to Data Display parts.
 - ☞ "11.3 Inverting a Bit ON/OFF" (page 11-7)
 - One barcode reader can be connected to each the COM1 and USB port, but when connecting two barcode readers at the same time and storing the code data in the Data Display parts or the internal device from both barcodes, the system may not work properly. Set the Data Display part to one barcode reader and the internal device to the other as a storage location.
 - If [Input Barcode] is not set in the [Input Permit] tab for the Data Display part, the read code data is not written to the Data Display part.
 - If the number of the read code data exceeds the [No. of Display Char.] set in a Data Display part, the data cannot be properly displayed on the Data Display part. The maximum number of display characters that can be set in a Data Display part is 100 (single-byte) characters.
-

■ Two-dimensional Code Reader

Configure settings to store the code data read from a two-dimensional code reader from LS20 in the GP.

NOTE • For more details, refer to the settings guide.
 ☞ “8.4.1 [Bar Code Settings] Settings Guide” (page 8-22)

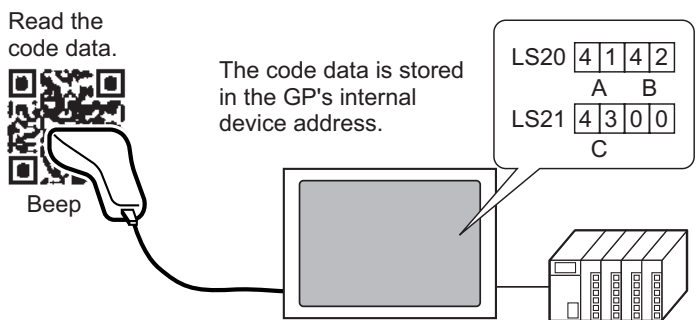

- 1 Select the [Project (F)] menu - [System Settings (C)] command, or click and then the System Settings Window's [Bar Code Settings]. The following [Bar Code Settings] screen is displayed.

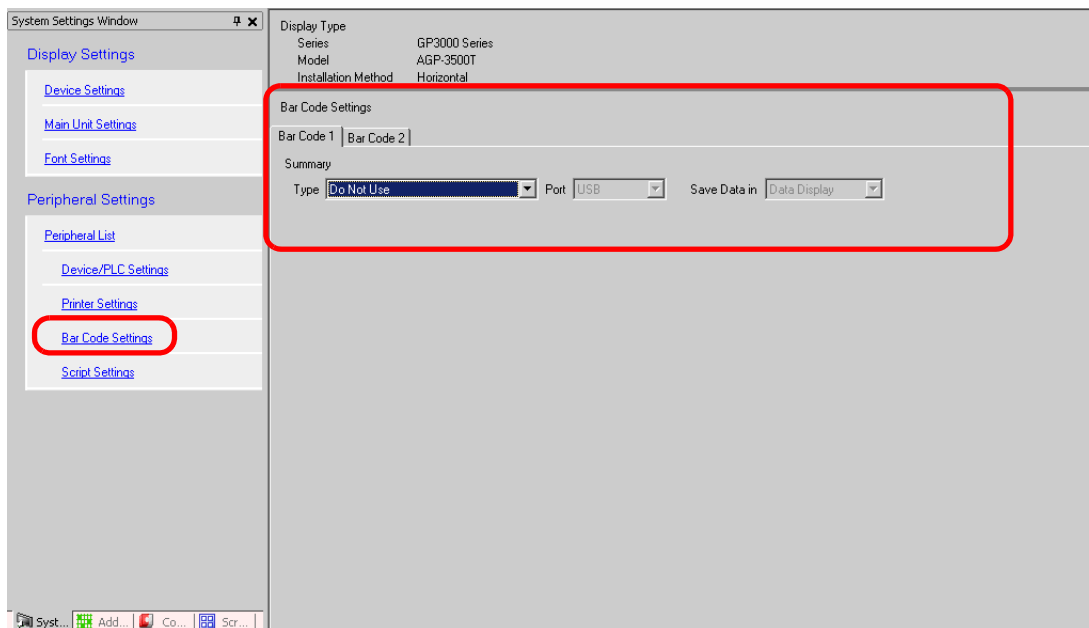

2 Select [Two-Dimensional Code Reader] in [Type].

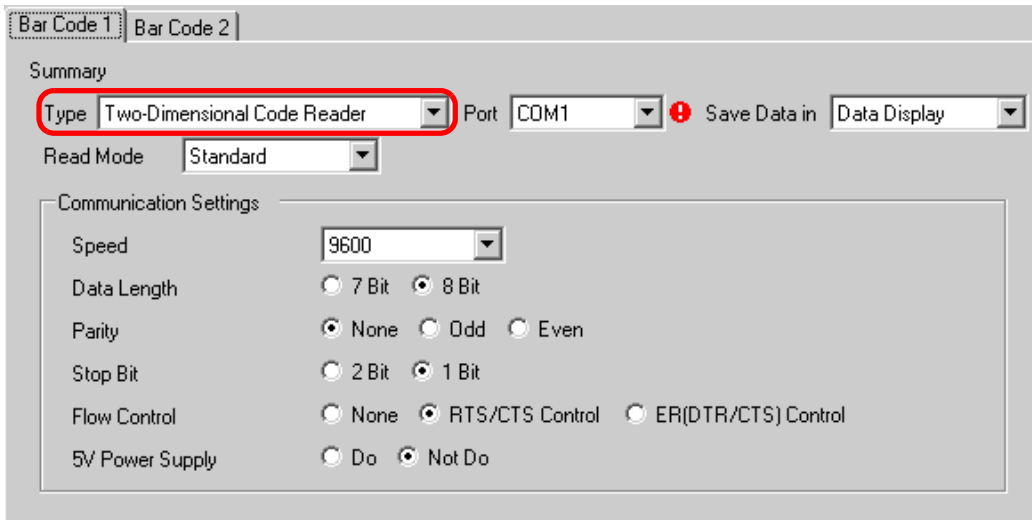

3 Select a port to connect to in [Port].

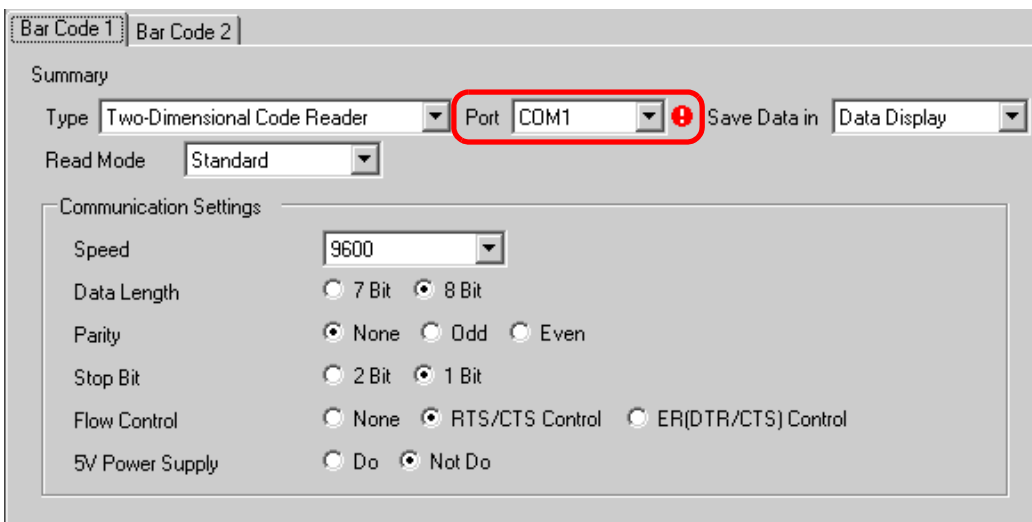

NOTE

- If the port is also used for other devices/PLCs,  is displayed to the right of the [Port] as above.
- A two-dimensional code reader can be set only to COM1.

4 Set the [Read Mode].

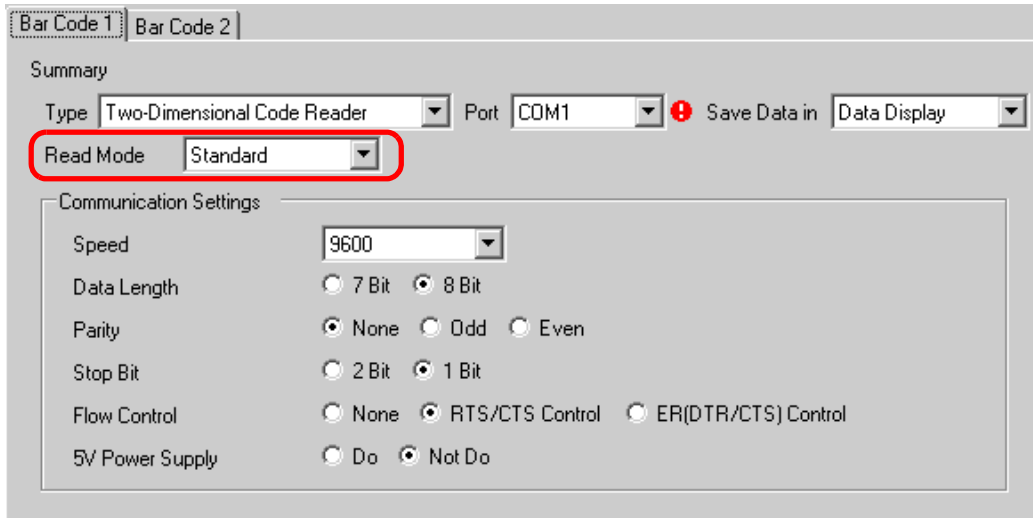

5 In [Communication Settings], set [Speed], [Data Length], [Parity], [Stop Bit], [Flow Control] and [5V Power Supply].

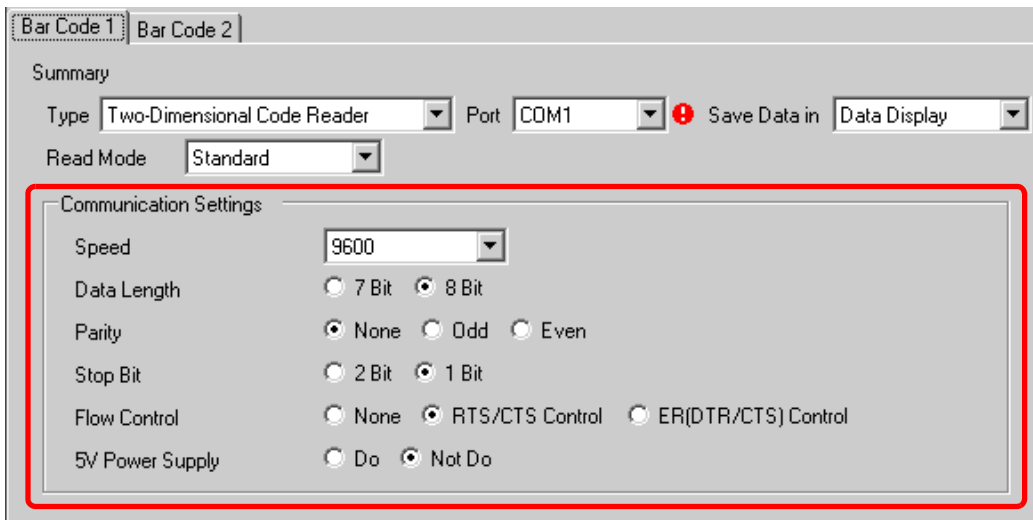

6 Select a data storage location in [Save Data in].

Bar Code 1 | Bar Code 2

Summary

Type: Two-Dimensional Code Reader | Port: COM1 | Save Data in: Internal Device

Read Mode: Standard

Communication Settings

Speed: 9600

Data Length: 7 Bit 8 Bit

Parity: None Odd Even

Stop Bit: 2 Bit 1 Bit

Flow Control: None RTS/CTS Control ER(DTR/CTS) Control

5V Power Supply: Do Not Do

Internal Device Settings

Internal Device Storage Start Address: [#INTERNAL]LS0020 [Extended Settings](#)

7 In [Internal Device Storage Start Address], set the data storage internal device's start address (e.g.: LS20).

Bar Code 1 | Bar Code 2

Summary

Type: Two-Dimensional Code Reader | Port: COM1 | Save Data in: Internal Device

Read Mode: Standard

Communication Settings

Speed: 9600

Data Length: 7 Bit 8 Bit

Parity: None Odd Even

Stop Bit: 2 Bit 1 Bit

Flow Control: None RTS/CTS Control ER(DTR/CTS) Control

5V Power Supply: Do Not Do

Internal Device Settings

Internal Device Storage Start Address: [#INTERNAL]LS0020 [Extended Settings](#)

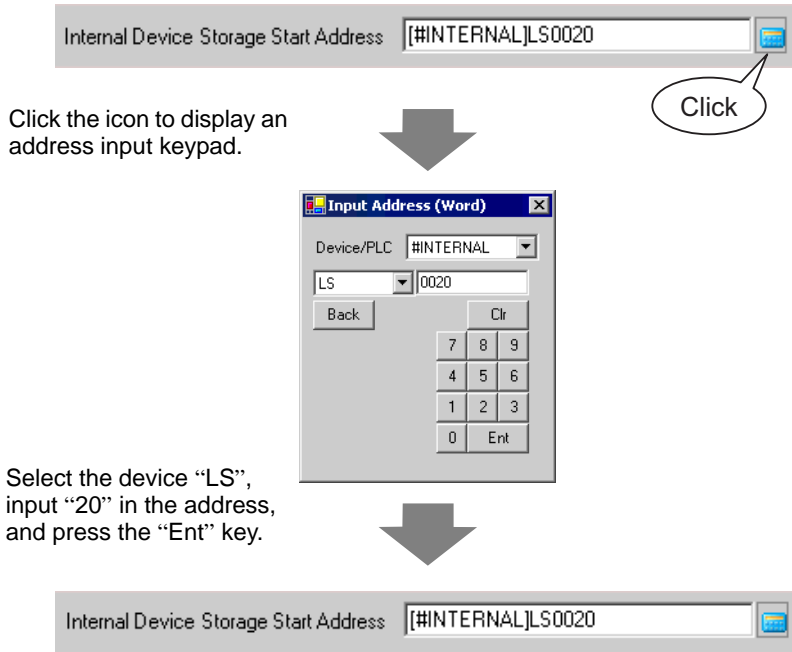

- NOTE** • For the internal device’s address setting range, refer to “8.3 Structure ■ Storing code data in the GP’s internal device address ◆ The Range of Internal Device Addresses” (page 8-21).

8 Click [Extended Settings] to display the [Extended Settings] dialog box, and set [Read Completion Bit], [Data Size] and [Initialization Settings].

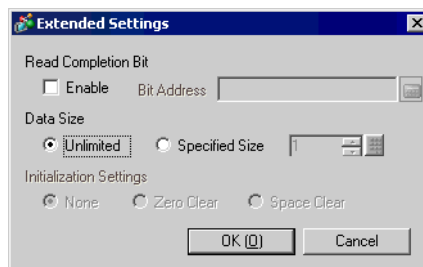

- NOTE** • When [Read Completion Bit] is not set, the data is overwritten if read continuously.
- If [Read Completion Bit] is set, turn OFF the [Read Completion Bit] when input is complete. The GP will not read code data if trying to read the next code data without turning the completion bit OFF.

8.3 Structure

■ Storing code data in the device/PLC's device address

Sets the Data Display part and stores the read code data in the Monitor Word Address that has been set to the Data Display part.

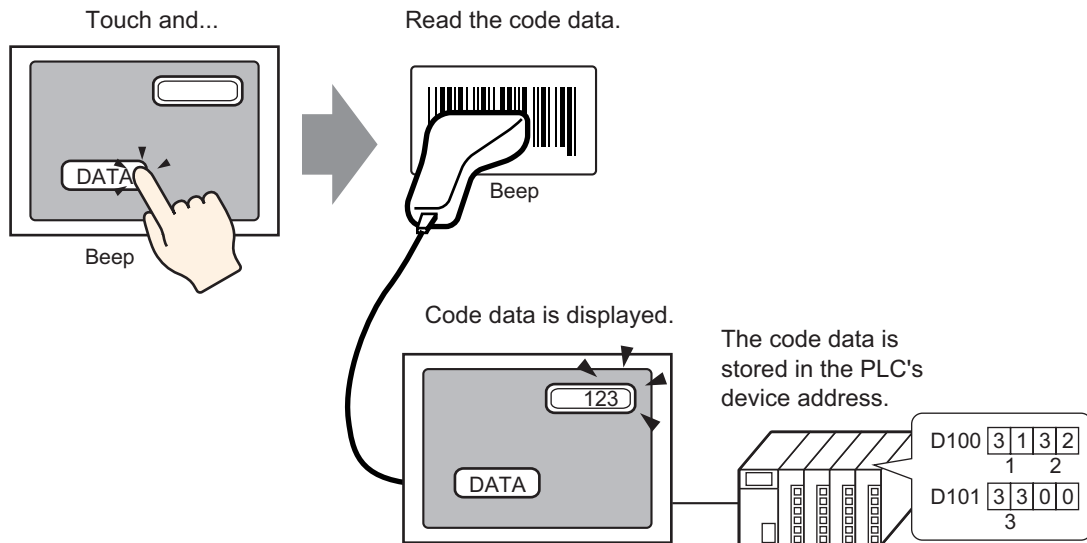

NOTE • If [Bar Code Settings] is not set to [Input Permit] in the Data Display part, the read code data is not written to the Data Display part.

■ Storing code data in the GP's internal device address

Sets the [Internal Device Storage Start Address] and stores the code data that has been read sequentially from it.

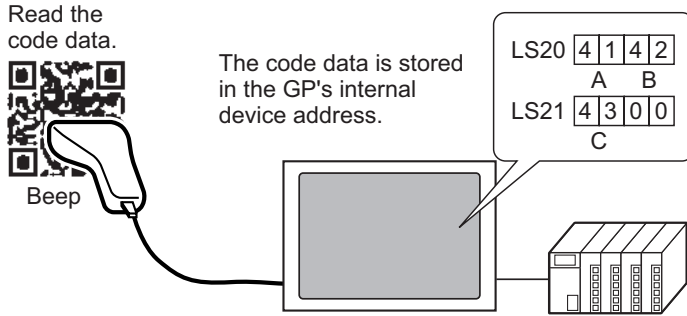

◆ Internal Device Storage Start Address

The read code data is stored from the [Internal Device Storage Start Address] in the following order.

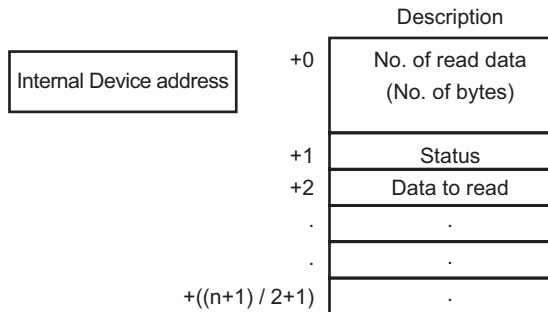

No. of Read Data (No. of Bytes) : The number of read data is stored by the number of bytes.

Status : If the code data is not read normally or is not written to the internal device address, an error code is stored.

Error Description

0000h	—
0001h	Read succeeded normally.
0002h	Code data read error. Not stored in internal device address.
0003h	Received code data exceeding the maximum number of bytes that the internal device address can store. The bytes of code data set in the [Extended Settings] - [Data Size] - [Assigned Size] is stored in the internal device address. In this case, the read completion bit address (when “Yes” is set) turns ON. The portion of code data exceeding the range is not written to the internal device address.

NOTE • The read two-dimensional code data is stored according to the [Text Data Mode] set in the GP.

☞ “ ■ [Device/PLC Settings] Settings Guide” (page 6-115)

◆ The Range of Internal Device Addresses

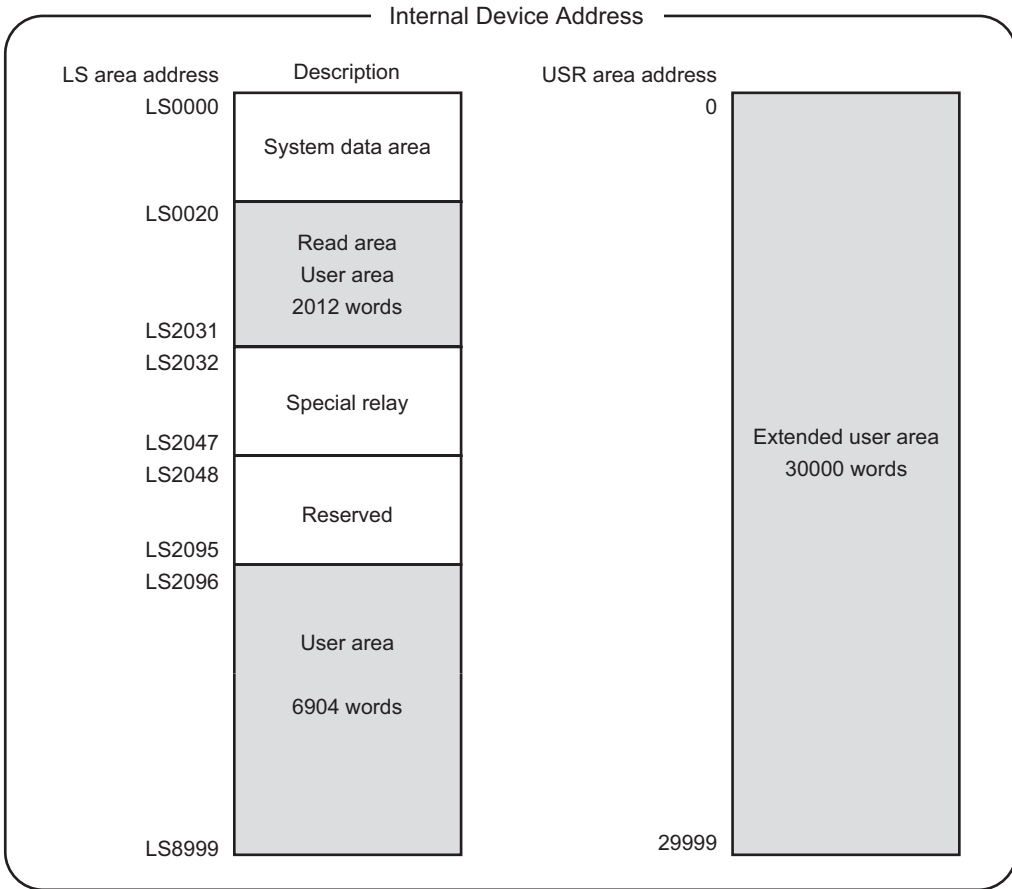

- NOTE**
- If the number of read code data is outside the above-mentioned range, the code data within the shaded range is written to the internal device address. However, the status is 0003h (Received code data exceeding the maximum number of bytes allowed for LS storage).

8.4 Settings Guide

8.4.1 [Bar Code Settings] Settings Guide

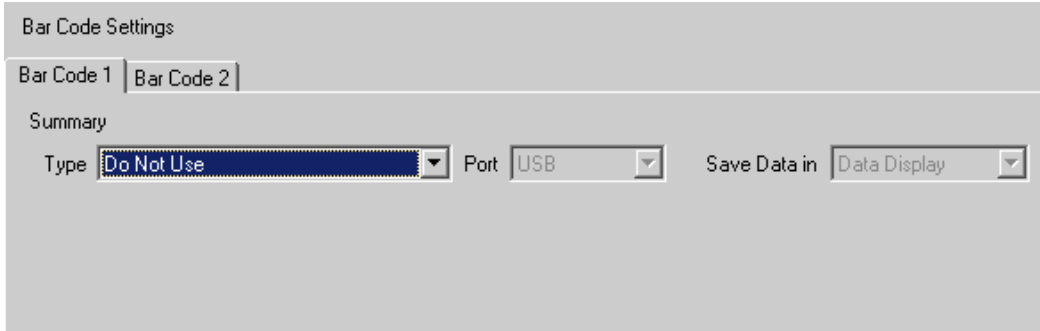

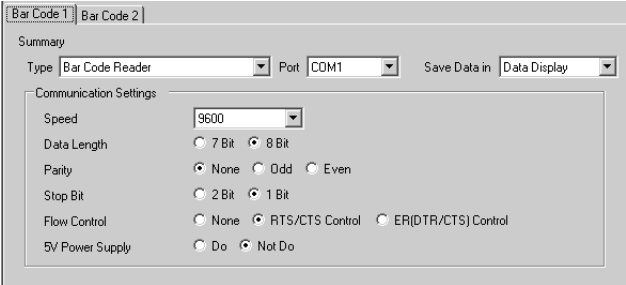
Setting		Description
Type		<p>Select the barcode type to connect.</p> <ul style="list-style-type: none"> • Do Not Use Select this when not connecting a barcode reader. • Bar Code Reader Select this when using a barcode reader. • Two-Dimensional Code Reader Select this when using a two-dimensional code reader.
	Do Not Use	<p>Select this when not using a barcode/two-dimensional code reader.</p> 
	Bar Code Reader	Select this when using a barcode reader.
	Port	Select the port to connect from [COM1] or [USB].
	COM1	<p>Select this when connecting to COM1.</p> 

Continued

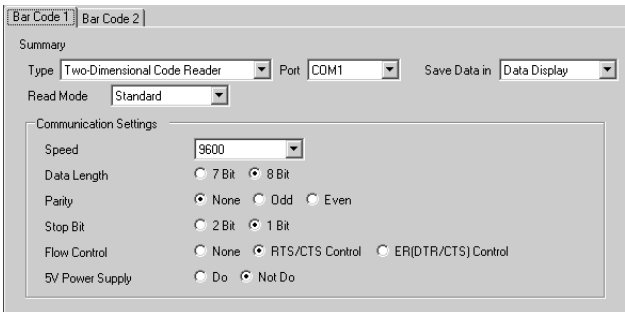
Setting				Description	
Type	Bar Code Reader	Port	COM1	Communication Settings	Configure communication settings.
				Speed	Select the communication speed from [2400], [4800], [9600], [19200], [38400], [57600] or [115200].
				Data Length	Choose the communication data length from [7 bit] or [8 bit].
				Parity	Select the communication parity bit from [Even], [Odd] or [None].
				Stop Bit	Choose the communication stop bit length from [1 bit] or [2 bit].
				Flow Control	Select the communication control method from [None], [RTS/CTS Control], or [ER (DTR/CTS) Control].
				5V Power Supply	Designate whether or not to set the 5V power supply.
	USB	Select this when connecting to the USB port.			
		Communication Settings	Configure communication settings.		
	Two-Dimensional Code Reader	Port	COM1	Key Code Settings	Select the text type that the barcode reader reads from [Japanese 106 Keypad] or [English 101 Keypad].
Select this when using a two-dimensional code reader.					
Set the port to connect to. Two-dimensional code reader can be set only to COM1.					
COM1	Select this when connecting to COM1.				

Continued

Setting				Description																			
Type	Two-Dimensional Code Reader	Port	COM1	<p>Communication Settings</p> <p>Configure communication settings.</p> <table border="1"> <tr> <td>Speed</td> <td>Select the communication speed from [2400], [4800], [9600], [19200], [38400], [57600] or [115200].</td> </tr> <tr> <td>Data Length</td> <td>Choose the communication data length from [7 bit] or [8 bit].</td> </tr> <tr> <td>Parity</td> <td>Select the communication parity bit from [Even], [Odd] or [None].</td> </tr> <tr> <td>Stop Bit</td> <td>Choose the communication stop bit length from [1 bit] or [2 bit].</td> </tr> <tr> <td>Flow Control</td> <td>Select the communication control method from [None], [RTS/CTS Control], or [ER (DTR/CTS) Control].</td> </tr> <tr> <td>5V Power Supply</td> <td>Designate whether or not to set the 5V power supply.</td> </tr> </table>	Speed	Select the communication speed from [2400], [4800], [9600], [19200], [38400], [57600] or [115200].	Data Length	Choose the communication data length from [7 bit] or [8 bit].	Parity	Select the communication parity bit from [Even], [Odd] or [None].	Stop Bit	Choose the communication stop bit length from [1 bit] or [2 bit].	Flow Control	Select the communication control method from [None], [RTS/CTS Control], or [ER (DTR/CTS) Control].	5V Power Supply	Designate whether or not to set the 5V power supply.							
		Speed	Select the communication speed from [2400], [4800], [9600], [19200], [38400], [57600] or [115200].																				
Data Length	Choose the communication data length from [7 bit] or [8 bit].																						
Parity	Select the communication parity bit from [Even], [Odd] or [None].																						
Stop Bit	Choose the communication stop bit length from [1 bit] or [2 bit].																						
Flow Control	Select the communication control method from [None], [RTS/CTS Control], or [ER (DTR/CTS) Control].																						
5V Power Supply	Designate whether or not to set the 5V power supply.																						
		Read Mode	<p>Select the read mode from [Standard], [DENSO], or [Tohken].</p> <ul style="list-style-type: none"> Standard <table border="1"> <tr> <td>Code Data</td> <td>Terminator (CR)</td> </tr> </table> <p>In [Standard] mode, binary data cannot be handled. In this mode, other makers' two-dimensional code readers can read data in the above setting.</p> DENSO QR Code Reader <table border="1"> <tr> <td>Header</td> <td>Code Mark</td> <td>No. of Digits (4 bytes)</td> <td>Code Data</td> <td>Terminator</td> <td>BCC</td> </tr> <tr> <td>STX (Fixed)</td> <td>Has code</td> <td>Has code</td> <td>—</td> <td>CR (Fixed)</td> <td>Has code</td> </tr> </table> <p>In [DENSO QR Code Reader] mode, binary data can be handled. But in this case, the above communication format needs to be set to a two-dimensional code reader as well.</p> Tohken Code Reader <table border="1"> <tr> <td>Header</td> <td>Code Data</td> <td>Terminator</td> </tr> <tr> <td>STX (Fixed)</td> <td>—</td> <td>CR+LF (Fixed)</td> </tr> </table> <p>In [Tohken Code Reader] mode, the above communication format needs to be set to a two-dimensional code reader as well. Binary data cannot be handled in [Tohken Code Reader] mode. Unlike DENSO's, the Tohken code reader does not check the number of digits or BBC and determines that the code data ends at the CR+LF code in the code data.</p> 	Code Data	Terminator (CR)	Header	Code Mark	No. of Digits (4 bytes)	Code Data	Terminator	BCC	STX (Fixed)	Has code	Has code	—	CR (Fixed)	Has code	Header	Code Data	Terminator	STX (Fixed)	—	CR+LF (Fixed)
Code Data	Terminator (CR)																						
Header	Code Mark	No. of Digits (4 bytes)	Code Data	Terminator	BCC																		
STX (Fixed)	Has code	Has code	—	CR (Fixed)	Has code																		
Header	Code Data	Terminator																					
STX (Fixed)	—	CR+LF (Fixed)																					
Save Data in		Select the read code data storage location from [Data Display] or [Internal Device].																					
Data Display		<p>Stores the read code data in the [Monitor Word Address] set on the Data Display part.</p> <p style="text-align: right;">Save Data in <input type="text" value="Data Display"/></p>																					

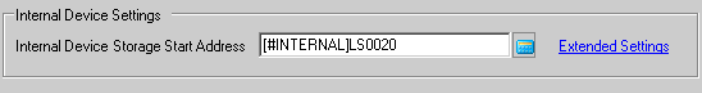
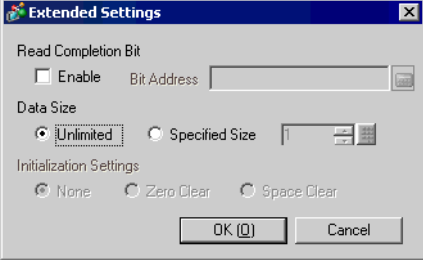
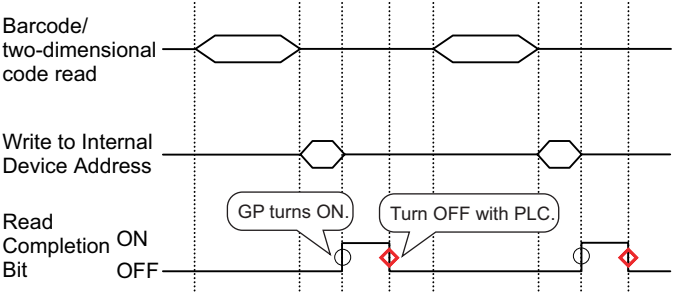

Continued

Setting		Description	
Save Data in	Internal Device	Stores the read code data in the internal device address. 	
	Internal Device Settings	Configure settings to store the read code data in the internal device. 	
	Internal Device Storage Start Address	Set the internal device address to store the read code data.	
	Extended Settings		
	Read Completion Bit	Enable	Designate whether or not to turn ON the read completion bit address if the entire code data has been written to the internal device address. NOTE <ul style="list-style-type: none"> When [Read Completion Bit] is not set, the code data is overwritten if read continuously.
		Bit Address	Set the read completion bit address. NOTE <ul style="list-style-type: none"> Return this bit to OFF after input has been completed. The GP will not read code data if trying to read the next code data without turning the read completion bit OFF. The barcode/two-dimensional code's read timing and the [Read Completion Bit Address]'s action are as follows:  <p>○ = GP turns ON. ◆ = Return the bit to OFF.</p>

Continued

Setting					Description
Save Data in	Internal Device	Internal Device Settings	Extended Settings	Data Size	Unlimited NOTE • If the read code data exceeds the enabled area, the excess data will not be written.
					Specified Size NOTE • If the read code data exceeds the [Specified Size], the excess data will not be written to the internal device address.

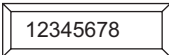
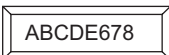
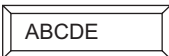
Continued

Setting				Description																			
Save Data in	Internal Device	Internal Device Settings	Extended Settings	Initialization Settings																			
					<p>Select the processing method when overwriting the read data code data from [None], [Zero Clear] or [Space Clear]. e.g.) If the code data “ABCDE” is stored to the previously stored code data “12345678”, the [Data Size] is 8 bytes.</p> <p>Previous Display: The 8-byte code data “12345678” is stored.</p> <p>(Actual display)  (In the internal device address)</p> <table border="1" data-bbox="816 492 1012 691"> <tr><td>+0</td><td>0</td><td>8</td></tr> <tr><td>+1</td><td>0</td><td>0</td></tr> <tr><td>+2</td><td>'1'</td><td>'2'</td></tr> <tr><td>+3</td><td>'3'</td><td>'4'</td></tr> <tr><td>+4</td><td>'5'</td><td>'6'</td></tr> <tr><td>+5</td><td>'7'</td><td>'8'</td></tr> </table> <p>Currently stored code data</p>	+0	0	8	+1	0	0	+2	'1'	'2'	+3	'3'	'4'	+4	'5'	'6'	+5	'7'	'8'
					+0	0	8																
					+1	0	0																
+2	'1'	'2'																					
+3	'3'	'4'																					
+4	'5'	'6'																					
+5	'7'	'8'																					
<p>Current Display: Reads the 5-byte code data “ABCDE”.</p> <ul style="list-style-type: none"> For [None] <p> (In the internal device address)</p> <table border="1" data-bbox="816 855 1012 1054"> <tr><td>+0</td><td>0</td><td>5</td></tr> <tr><td>+1</td><td>0</td><td>0</td></tr> <tr><td>+2</td><td>'A'</td><td>'B'</td></tr> <tr><td>+3</td><td>'C'</td><td>'D'</td></tr> <tr><td>+4</td><td>'E'</td><td>'6'</td></tr> <tr><td>+5</td><td>'7'</td><td>'8'</td></tr> </table> <p>Displayed with the previous display remaining.</p>	+0	0	5	+1	0	0	+2	'A'	'B'	+3	'C'	'D'	+4	'E'	'6'	+5	'7'	'8'					
+0	0	5																					
+1	0	0																					
+2	'A'	'B'																					
+3	'C'	'D'																					
+4	'E'	'6'																					
+5	'7'	'8'																					
<ul style="list-style-type: none"> For [Zero Clear] (data clear with Null) <p> (In the internal device address)</p> <table border="1" data-bbox="816 1122 1012 1321"> <tr><td>+0</td><td>0</td><td>5</td></tr> <tr><td>+1</td><td>0</td><td>0</td></tr> <tr><td>+2</td><td>'A'</td><td>'B'</td></tr> <tr><td>+3</td><td>'C'</td><td>'D'</td></tr> <tr><td>+4</td><td>'E'</td><td>00h</td></tr> <tr><td>+5</td><td>00h</td><td>00h</td></tr> </table> <p>The previous code data is overwritten with NULL = "00 (h)".</p>	+0	0	5	+1	0	0	+2	'A'	'B'	+3	'C'	'D'	+4	'E'	00h	+5	00h	00h					
+0	0	5																					
+1	0	0																					
+2	'A'	'B'																					
+3	'C'	'D'																					
+4	'E'	00h																					
+5	00h	00h																					
<ul style="list-style-type: none"> For [Space Clear] <p> (In the internal device address)</p> <table border="1" data-bbox="816 1389 1012 1588"> <tr><td>+0</td><td>0</td><td>5</td></tr> <tr><td>+1</td><td>0</td><td>0</td></tr> <tr><td>+2</td><td>'A'</td><td>'B'</td></tr> <tr><td>+3</td><td>'C'</td><td>'D'</td></tr> <tr><td>+4</td><td>'E'</td><td>20h</td></tr> <tr><td>+5</td><td>20h</td><td>20h</td></tr> </table> <p>The previous code data is overwritten with a space_ = "20(h)".</p>	+0	0	5	+1	0	0	+2	'A'	'B'	+3	'C'	'D'	+4	'E'	20h	+5	20h	20h					
+0	0	5																					
+1	0	0																					
+2	'A'	'B'																					
+3	'C'	'D'																					
+4	'E'	20h																					
+5	20h	20h																					

8.5 Restrictions

- If the [Save Data in] is set to [Internal Device] and [Read Completion Bit] is set, turn OFF the [Read Completion Bit] when input is complete. The GP will not read code data if trying to read the next code data without turning the read completion bit OFF.
- When the [Parity] is [None] and the communication speed settings for the barcode reader are different from those of the GP, the system may read invalid data because it cannot detect errors. Use the same communication settings for both the devices.
- When [Read Completion Bit] is not set, the code data is overwritten if read continuously.
- If switching between screens while inputting, the switching process takes priority and the data being input is ignored.
- If [Bar Code Settings] is not set in the [Input Permit] tab for the Data Display part, the read code data is not written to the Data Display part.
- If the number of the read code data exceeds the [No. of Display Char.] set in a Data Display part, the data cannot be properly displayed on the Data Display part. The maximum number of display characters that can be set in a Data Display part is 100 (single-byte) characters.
- One barcode reader can be connected to each the COM1 and USB port, but when connecting two barcode readers at the same time and storing the code data in the Data Display parts or the internal device from both barcodes, the system may not work properly. Set the Data Display part to one barcode reader and the internal device to the other as a storage location.