

# Appendix

“A.1 - Communication” introduces the communication methods to connect the GP and a device/PLC. “A.2 - Executing Multiple Actions (Programs) with a Switch Operation” explains the Trigger Action part.

“A.3 - Drawing Using Foreign Languages” describes how to draw switches using foreign languages, starting from the preparations needed for foreign language input, through actual switch label input. The descriptions use Chinese as an example.

A.1	Communication .....	A-2
A.2	Executing Multiple Actions (Programs) with a Switch Operation .....	A-38
A.3	Drawing Using Foreign Languages.....	A-55

## A.1 Communication

**NOTE** • For information about connection methods between the GP and device/PLC, please refer to the GP-Pro EX Device/PLC Connection Manual.

### A.1.1 Settings Menu

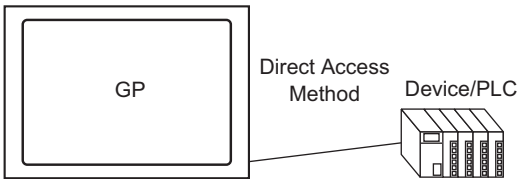
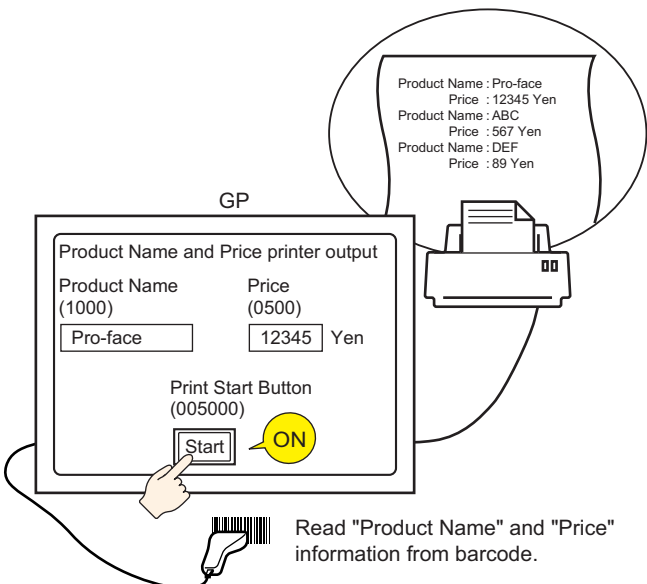
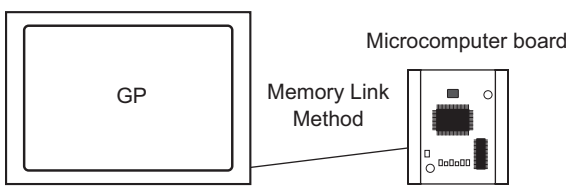
<b>Communicating with a Device/PLC without Burdening it (Direct Access Method)</b>	
<p>This is useful when connecting to a device/PLC that is supported by the GP.</p>  <p>The diagram shows a box labeled 'GP' connected by a line to a rack of hardware labeled 'Device/PLC'. The connection is labeled 'Direct Access Method'.</p>	<ul style="list-style-type: none"> <li>☞ Setup Procedure (page A-3)</li> <li>☞ Details (page A-3)</li> </ul>
<b>Communicating with Unsupported Devices/PLCs (Memory Link Method)</b>	
<p>Connect the bar code reader to the USB port, and create an extended script to output the read data to the serial printer connected to COM1.</p>  <p>The diagram shows a GP screen with a 'Print Start Button (005000)' and a 'Start' button. A hand is shown pressing the 'Start' button. A barcode reader is connected to the GP. A printer is connected to the GP. The printer is printing a receipt with the following text:</p> <pre> Product Name : Pro-face Price : 12345 Yen Product Name : ABC Price : 567 Yen Product Name : DEF Price : 89 Yen     </pre> <p>Read "Product Name" and "Price" information from barcode.</p>	<ul style="list-style-type: none"> <li>☞ Setup Procedure (page 20-35)</li> <li>☞ Details (page 20-22)</li> </ul>
<p>Create and execute all programs needed to communicate on the device/PLC side (computer, microprocessor board). (Memory Link Method)</p>  <p>The diagram shows a box labeled 'GP' connected by a line to a 'Microcomputer board'. The connection is labeled 'Memory Link Method'.</p>	<ul style="list-style-type: none"> <li>☞ Setup Procedure (page A-5)</li> <li>☞ Details (page A-5)</li> </ul>

## A.1.2 Communicating with a Device/PLC without Burdening it (Direct Access Method)

### A.1.2.1 Details

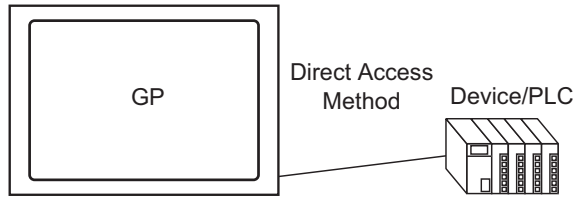

In order to communicate with a device/PLC, use the communication method called “Direct Access” which puts a smaller program burden on the device/PLC.

#### ■ Direct Access Method

In the “Direct Access Method”, the GP makes an inquiry (request) to the device/PLC, as in the following image. The device/PLC then responds to the request from the GP.

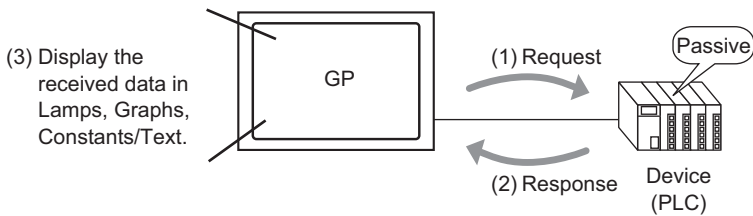

#### ◆ Usable Addresses

In order for the GP to be able to get the necessary display data from the device/PLC when communicating, designate an address that can reference data used for Parts and script features. There are two types of addresses which can be set as reference destinations.

- Device/PLC Addresses

It can reference the device/PLC’s data.

Select the device/PLC name (e.g. “PLC1”) that will communicate with the GP, and input that model’s address (e.g. “D00000”).

(e.g. An Input Address screen on a “Word Switch”)

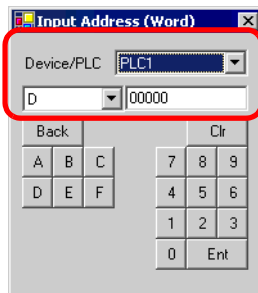

- GP Internal Device Addresses

This can be used as a data storage destination, for example, when storing calculated values temporarily inside the GP, or when temporarily controlling data in the GP. When referencing that data, select [#INTERNAL] (refers to the GP internal device) as the [Device/PLC] that will communicate with the GP, and input that address (e.g. “USR0000”).

(e.g. An Input Address screen on a “Word Switch”)

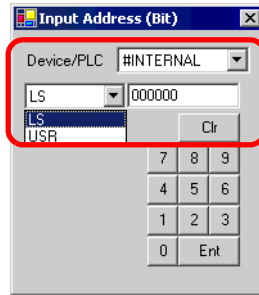

The GP’s internal device [#INTERNAL], has two structured areas: the [LS] area and the [USR] are (shown below).

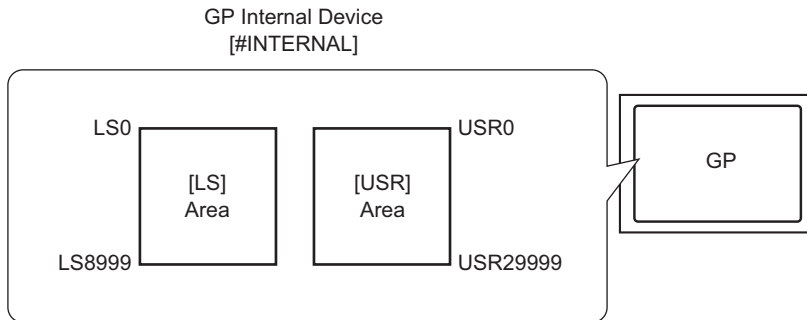

- [LS] Area

This is a user area that can be used freely, and an area used for running the GP.

☞ “A.1.4 LS Area (Direct Access Method)” (page A-8)

- [USR] Area

This area has 30,000 words and can be used freely as a user area.

### A.1.3 Communicating with Unsupported Devices/PLCs (Memory Link Method)

#### A.1.3.1 Details

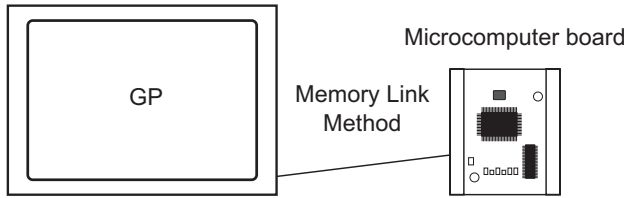

The communication method called “Memory Link” is used in order to connect with devices (here, called “hosts”) that do not contain a communication protocol, such as a computer or a microprocessor board.

#### ■ Memory Link Method

In the “Memory Link Method”, a data read/write request occurs from the host to the GP, as in the following image. The GP displays data on a screen that was sent in response to the host’s write request. In response to a read request, the GP sends data stored inside the GP to the host.

**NOTE** • Communication based on the Memory Link Method is accomplished by executing a program on the host.

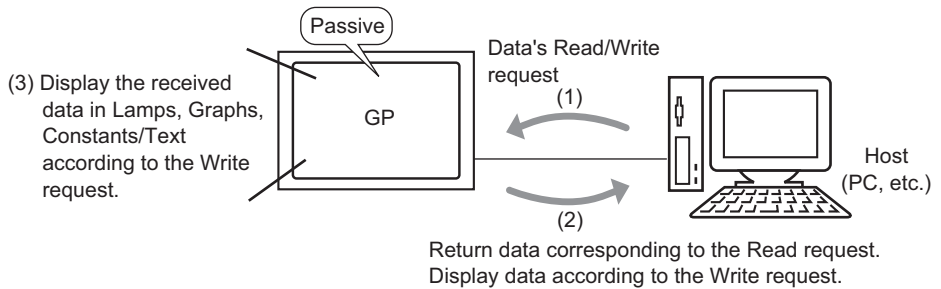

◆ Usable Addresses

In order for the GP to be able to get the necessary display data from the host when communicating, designate an address that can reference data and set the Parts or script features. There are two types of address inside the GP that can be set as a reference destination.

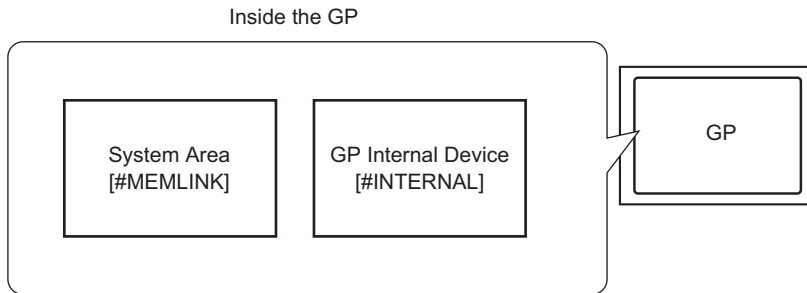

- Memory Link System Area Addresses

The System Area is a medium used in order to request the host’s read/write. It is the Memory Link Method’s communication area.

For details about the System Area, please refer to “A.1.5 System Area (Memory Link Area)” (page A-22) .

For example, to set a “Word Switch”’s address settings, select [#MEMLINK] from [Device/PLC], and input that model’s address (e.g. “0100”).

(e.g. An Input Address screen on a “Word Switch”)

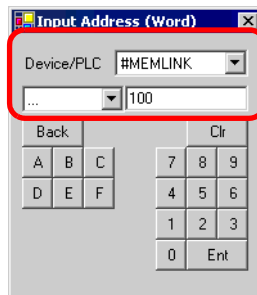

- GP Internal Device Addresses

For example, designate this when referencing the destination of a calculated value stored temporarily inside the GP.

Select [#INTERNAL] (refers to the GP internal device) as the [Device/PLC] that will communicate with the GP, and input that address (e.g. “USR00100”).

(e.g. An Input Address screen on a “Word Switch”)

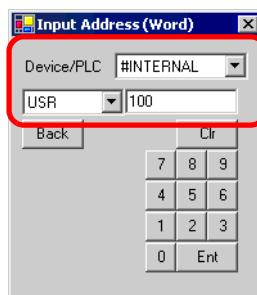

The GP's internal device [#INTERNAL], has two structured areas: the [LS] area and the [USR] are (shown below). However, the Memory Link Method can only use the [USR] area for communication.

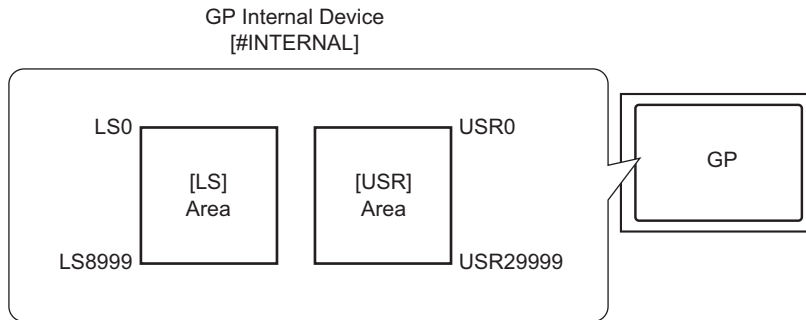

### [LS] Area

This is a user area that can be used freely, and an area used for running the GP.

☞ “A.1.4 LS Area (Direct Access Method)” (page A-8)

---

**IMPORTANT**

- This cannot be used to communicate by Memory Link Method.
- 

### [USR] Area

This area has 30,000 words and can be used freely as a user area.

### A.1.4 LS Area (Direct Access Method)

When communicating inside the GP by Direct Access Method, the LS area is secured. This area is useful for temporarily storing control handling only within the GP without a device/PLC address (e.g. a switch's Interlock Settings), or for temporarily storing values calculated within the GP.

#### A.1.4.1 LS Area List

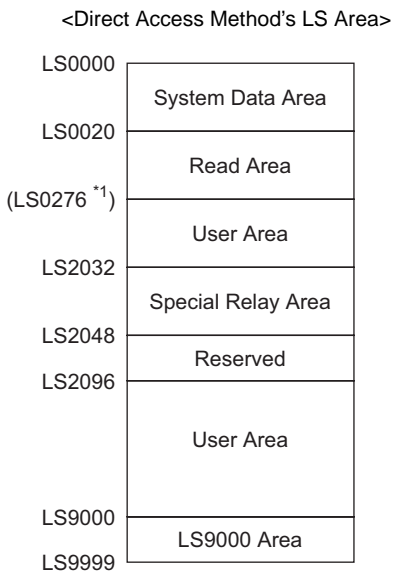

**IMPORTANT**

- Please do not set addresses for Parts which span the System Data Area and Read Area, or the Read Area and User Area.
- When setting addresses for Parts in the System Data Area, please designate the data length as 16 bit.

\*1 The System Data Area can exclusively use a maximum of 20 words. The Read Area can exclusively use a maximum of 256 words. The User Area's top address is the Read Area's top address (20) + Read Area's size.

Area Name	Description
System Data Area	<p>This area stores data necessary for the system's operation, such as the GP's screen control data and error information.</p> <p>☞ "A.1.4.2 System Data Area" (page A-10)</p> <p>When referencing a screen number displayed on the GP from a device/PLC or changing screens, to automatically reference/control the GP's data, establish an area in the device/PLC to link with this area.</p> <p>☞ "A.1.4.4 Device/PLC's System Data Area Allotment Procedure" (page A-19)</p>

Continued

Area Name	Description
Read Area	This area stores data used commonly by all screens and data for Data Block Display Graphs. The area size is variable and can be set up to 256 words. When referencing a screen number displayed on the GP from a device/PLC or changing screens, to automatically reference/control the GP's data, establish an area in the device/PLC to link with this area. ☞ "A.1.4.4 Device/PLC's System Data Area Allotment Procedure" (page A-19)
User Area	This device can only be allotted inside the GP and cannot be allotted to the device/PLC. Use it for addresses that can only be processed with the GP. You cannot control it from the device/PLC.
Special Relay Area	This area stores each type of status information that occurs when the GP communicates. ☞ "A.1.4.3 Special Relay" (page A-16)
Reserved	Used inside the GP. Please do not use this area. Otherwise, it will not function normally.
LS9000 Area	Stores the GP's internal operating information such as a Trend Graph's historical data and the communication scan time. There is also an adjustable portion. ☞ "7.3.2 Setup Procedure ■ Disconnecting the Communication" (page 7-13)

**NOTE**

- The LS Area is designated in the following way.

- ◆ For Word Address designation

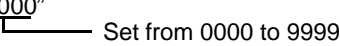
- (e.g.) "LS0000"  

 Set from 0000 to 9999

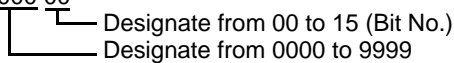
- ◆ For Bit Address designation

- (e.g.) "LS0000 00"  

 Designate from 00 to 15 (Bit No.)  
 Designate from 0000 to 9999

### A.1.4.2 System Data Area

This shows the contents of write data in each address of the System Data Area.

#### ■ When one address is communicating with a 16 bit device/PLC

**NOTE** • The following table's "Word Address" column shows the word addresses added from the System Data Area's top address in the device/PLC. (When all items are selected from the GP's LS0000 to LS0019)

	GP's Address	Word Address	Description	Bit	Details
Write Area GP to PLC	LS0000	+0	Current Screen No.	—	1 to 9999 (BIN) 1 to 7999 (BCD)
	LS0001	+1	Error Status	0 to 2	Unused
				3	Screen Memory Check Sum
				4	SIO Framing
				5	SIO Parity
				6	SIO Overrun
				7 to 9	Unused
				10	Backup Battery Low Voltage
				11	PLC Communication Error
	12 to 15	Unused			
	LS0002	+2	Clock's current "Year" value	—	Last 2 digits of year ( 2 BCD digits)
	LS0003	+3	Clock's current "Month" value	—	01 to 12 (2 BCD digits)
	LS0004	+4	Clock's current "Day" value	—	01 to 31 (2 BCD digits)
	LS0005	+5	Clock's current "Time" value	—	Hour: 00 to 23, Minute: 00 to 59 (4 BCD digits)
	LS0006	+6	Status	0 to 1	Reserved
				2	Printing
				3	Data Display Part Write Setting Value
4 to 7				Reserved	
8				Data Display Part Input Error	
9				Display ON/OFF 0: ON, 1: OFF	
10				Expired backlight detected	
11 to 15	Reserved				
LS0007	+7	Reserved	—	Reserved	

Continued

	GP's Address	Word Address	Description	Bit	Details
Read Area GP to PLC	LS0008	+8	Change - To Screen No.	—	When reflecting Change-To Screen No. in the device/PLC 1 to 9999 (BIN) 1 to 7999 (BCD)
	LS0009	+9	Screen Display ON/OFF	—	Turn Screen Display OFF with FFFFh Display screen with 0h
	LS0010	+10	Clock's "Year" setting value	—	Last 2 digits of year ( 2 BCD digits) (Bit 15 is the clock data's rewrite flag)
	LS0011	+11	Clock's "Month" setting value	—	01 to 12 (2 BCD digits)
	LS0012	+12	Clock's "Day" setting value	—	01 to 31 (2 BCD digits)
	LS0013	+13	Clock's "Time" setting value	—	Hour: 00 to 23, Minute: 00 to 59 (4 BCD digits)
	LS0014	+14	Control	0	Backlight OFF
				1	Buzzer ON
				2	Print Started
				3	Reserved
				4	Buzzer
				5	AUX Output
				6 to 10	Reserved
				11	Print Cancelled
	12 to 15	Reserved			
	LS0015	+15	Reserved	—	Reserved
	LS0016	+16	Window Control	0	Show Window 0: OFF, 1: ON
1				Change Window overlap order 0: Permitted, 1: Not permitted	
2 to 15				Reserved	
LS0017	+17	Window Screen No.	—	Global Window's registration number selected by indirect designation 1 to 2000 (BIN/BCD)	
LS0018	+18	Window Display Position (X Coordinate)	—	Global Window's top-left display position, selected by indirect designation (Bin/BCD)	
LS0019	+19	Window Display Position (Y Coordinate)	—		

**IMPORTANT**

- Normally, when turning OFF the Screen Display, do not use +14 (Control)'s "Backlight OFF" bit, please use +9 (Screen Display ON/OFF).

**NOTE**

- The "Word Addresses" in this table are the values which would appear if you put a check mark next to the [Enable System Data Area] box and selected all of the items.

Description	Details																														
Current Screen No.	Stores the screen number currently displayed by the GP.																														
Error Status	<p>When an error occurs in the GP, the corresponding bit turns ON. After the bit turns ON and the power turns OFF, the status is maintained until it changes from offline mode back to active mode.</p> <table border="1" data-bbox="385 330 1252 745"> <thead> <tr> <th>Bit</th> <th>Description</th> <th>Details</th> </tr> </thead> <tbody> <tr> <td>0 to 2</td> <td>Unused</td> <td></td> </tr> <tr> <td>3</td> <td>Screen Memory Check Sum</td> <td>There is an error in the project file. Please transfer it again.</td> </tr> <tr> <td>4</td> <td>SIO Framing</td> <td></td> </tr> <tr> <td>5</td> <td>SIO Parity</td> <td></td> </tr> <tr> <td>6</td> <td>SIO Overrun</td> <td></td> </tr> <tr> <td>7 to 9</td> <td>Unused</td> <td></td> </tr> <tr> <td>10</td> <td>Backup Battery Low Voltage</td> <td>This turns ON when the voltage of the backup lithium battery is low. The backup battery is used by the clock and SRAM.</td> </tr> <tr> <td>11</td> <td>PLC Communication Error</td> <td>Error in communication with device/PLC, caused by bits 4 to 6, or other cause.</td> </tr> <tr> <td>12 to 15</td> <td>Unused</td> <td></td> </tr> </tbody> </table>	Bit	Description	Details	0 to 2	Unused		3	Screen Memory Check Sum	There is an error in the project file. Please transfer it again.	4	SIO Framing		5	SIO Parity		6	SIO Overrun		7 to 9	Unused		10	Backup Battery Low Voltage	This turns ON when the voltage of the backup lithium battery is low. The backup battery is used by the clock and SRAM.	11	PLC Communication Error	Error in communication with device/PLC, caused by bits 4 to 6, or other cause.	12 to 15	Unused	
	Bit	Description	Details																												
	0 to 2	Unused																													
	3	Screen Memory Check Sum	There is an error in the project file. Please transfer it again.																												
	4	SIO Framing																													
	5	SIO Parity																													
	6	SIO Overrun																													
	7 to 9	Unused																													
	10	Backup Battery Low Voltage	This turns ON when the voltage of the backup lithium battery is low. The backup battery is used by the clock and SRAM.																												
	11	PLC Communication Error	Error in communication with device/PLC, caused by bits 4 to 6, or other cause.																												
12 to 15	Unused																														
Clock Data (Current)	<p>Stored as BCD. [Year] is the 2 final digits of the year, [Month] is 2 digits from 01 to 12, [Day] is 2 digits from 01 to 31, [Time] is 2 hour digits from 00 to 23 and 2 minute digits from 00 to 59 for a total of 4 digits.</p> <p><b>NOTE</b></p> <ul style="list-style-type: none"> <li>The current value for the day is stored in LS9310. The day is calculated from the Year, Month, and Day of the GP's on-board IC (RTC) clock.</li> </ul> <p>The value is stored in LS9310 as follows.</p> <table border="1" data-bbox="635 1070 1039 1408"> <thead> <tr> <th>Numeric Value</th> <th>Description</th> </tr> </thead> <tbody> <tr> <td>0</td> <td>Sunday</td> </tr> <tr> <td>1</td> <td>Monday</td> </tr> <tr> <td>2</td> <td>Tuesday</td> </tr> <tr> <td>3</td> <td>Wednesday</td> </tr> <tr> <td>4</td> <td>Thursday</td> </tr> <tr> <td>5</td> <td>Friday</td> </tr> <tr> <td>6</td> <td>Saturday</td> </tr> <tr> <td>7</td> <td>Unused</td> </tr> </tbody> </table> <p>Updates are performed when the IC clock's date is changed. Because the writes do not occur regularly, when parts change this area, this area will not be updated the next time until the IC clock's date changes.</p>	Numeric Value	Description	0	Sunday	1	Monday	2	Tuesday	3	Wednesday	4	Thursday	5	Friday	6	Saturday	7	Unused												
Numeric Value	Description																														
0	Sunday																														
1	Monday																														
2	Tuesday																														
3	Wednesday																														
4	Thursday																														
5	Friday																														
6	Saturday																														
7	Unused																														

Continued

Description	Details		
Status	Please monitor only the necessary bits. Reserved bits are sometimes used for GP system maintenance, so do not turn them ON/OFF.		
	Bit	Description	Details
	0, 1	Reserved	—
	2	Printing	Turns ON during printing. While this bit is ON, there are cases when the offline screen will appear, or when output will be disturbed.
	3	Write Setting Value	This bit is reversed each time a write occurs from a Data Display (Setting Value Input).
	4 to 7	Reserved	—
	8	Data Display Part Input Error	When Alarm Settings are set on the Data Display where you are currently inputting and you input a value outside of the alarm range, this bit turns ON. When you input a value inside the alarm range or change screens, this bit turns OFF.
	9	Display ON/OFF (0: ON, 1: OFF)	<p>This can detect whether to turn the GP's screen display ON/OFF from the device/PLC.</p> <p>This bit will change in the following cases.</p> <p>(1) When FFFFh is written to the System Data Area's Display ON/OFF, the display turns OFF.</p> <p>(2) When the standby time passes, the display will automatically turn OFF</p> <p>(3) If the screen changes or is touched after the display turns OFF, the display will turn back ON.</p> <p><b>NOTE</b></p> <ul style="list-style-type: none"> <li>This bit cannot change LS0014 "Control"'s 0 bit (Backlight OFF).</li> </ul>
	10	Expired backlight detected	When an expired backlight is detected, this bit turns ON.
11 to 15	Reserved	—	

Continued

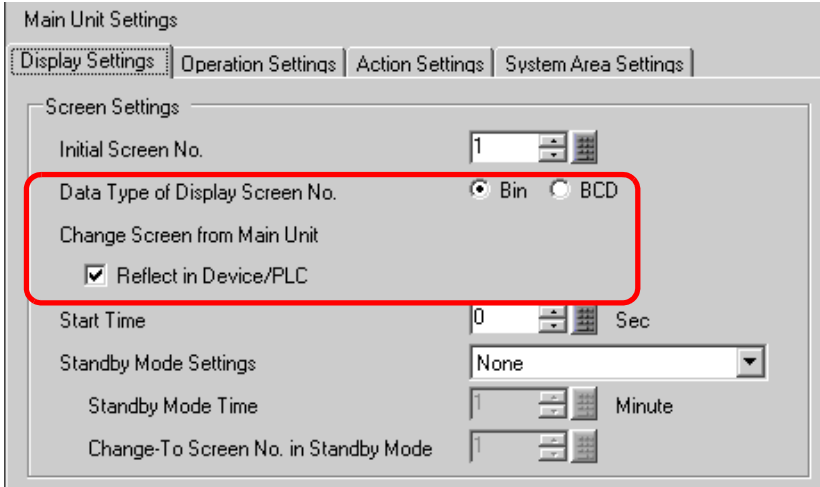
Description	Details																		
<p>Change - To Screen No.</p>	<p>Set the Change-to Screen No. The setting range differs depending on whether or not [Data Type of Display Screen No.] and [Change Screen from Main Unit - Reflect in Device/PLC] are set on the System Settings - [Main Unit Settings] - [Display Settings] tab.</p>  <p>When [Data Type of Display Screen No.] is [Bin]</p> <table border="1" data-bbox="399 886 1171 1018"> <thead> <tr> <th>Reflect in Device/PLC</th> <th>Screen Change from Device/PLC</th> <th>Screen Change from Main Unit (Switch, etc.)</th> </tr> </thead> <tbody> <tr> <td>Checked</td> <td>1 to 9999</td> <td>1 to 9999</td> </tr> <tr> <td>Unchecked</td> <td>1 to 9999</td> <td>1 to 9999</td> </tr> </tbody> </table> <p>When [Data Type of Display Screen No.] is [BCD]</p> <table border="1" data-bbox="399 1087 1171 1219"> <thead> <tr> <th>Reflect in Device/PLC</th> <th>Screen Change from Device/PLC</th> <th>Screen Change from Main Unit (Switch, etc.)</th> </tr> </thead> <tbody> <tr> <td>Checked</td> <td>1 to 7999</td> <td>1 to 7999</td> </tr> <tr> <td>Unchecked</td> <td>1 to 1999</td> <td>1 to 7999</td> </tr> </tbody> </table>	Reflect in Device/PLC	Screen Change from Device/PLC	Screen Change from Main Unit (Switch, etc.)	Checked	1 to 9999	1 to 9999	Unchecked	1 to 9999	1 to 9999	Reflect in Device/PLC	Screen Change from Device/PLC	Screen Change from Main Unit (Switch, etc.)	Checked	1 to 7999	1 to 7999	Unchecked	1 to 1999	1 to 7999
Reflect in Device/PLC	Screen Change from Device/PLC	Screen Change from Main Unit (Switch, etc.)																	
Checked	1 to 9999	1 to 9999																	
Unchecked	1 to 9999	1 to 9999																	
Reflect in Device/PLC	Screen Change from Device/PLC	Screen Change from Main Unit (Switch, etc.)																	
Checked	1 to 7999	1 to 7999																	
Unchecked	1 to 1999	1 to 7999																	
<p>Screen Display ON/OFF</p>	<p>Displays when the value is “0h”, hides the screen when the value is “FFFFh”. Values other than “0h” and “FFFFh” are reserved. When the screen display is hidden (when the value becomes “FFFFh”), the next touch on the screen will turn the display back ON.</p>																		
<p>Clock Data (Setting Value)</p>	<p>Set as BCD. [Year] is the 2 final digits of the year, [Month] is 2 digits from 01 to 12, [Day] is 2 digits from 01 to 31, [Time] is 2 hour digits from 00 to 23 and 2 minute digits from 00 to 59 for a total of 4 digits.</p> <p>■ Setting Example: October 19th, 2005, 21:57</p> <p>(1) When the current Word Address “+10”'s data is “0000”,</p> <ul style="list-style-type: none"> <li>• “Month” - Write “0010” to Word Address “+11”</li> <li>• “Day” - Write “0019” to Word Address “+12”</li> <li>• “Time” - Write “2157” to Word Address “+13”</li> </ul> <p>(2) When you write “8005” to Word Address “+10”, bit 15 of “+10” turns ON, and clock data is rewritten. For “8005”, bit 15 is turned ON by the “8000” portion, while the “Year” is set with “05”.</p>																		

Continued

Description	Details		
Control	<p><b>NOTE</b></p> <ul style="list-style-type: none"> <li>• Please make sure to write this address in bit units. In some cases, writing with word data will change the value.</li> <li>• “Reserved” bits are sometimes used for maintenance of the GP’s system so please turn them OFF.</li> </ul>		
	Bit	Description	Details
	0	Backlight OFF	When ON, the backlight turns OFF, when OFF, the backlight turns ON. (The parts placed on the screen will still function after the LCD is lit.) <p><b>NOTE</b></p> <ul style="list-style-type: none"> <li>• Normally, when turning OFF the screen display, please use Word Address “+9” (Screen Display ON/OFF).</li> </ul>
	1	Buzzer ON	0: Do not sound, 1: Sound
	2	Print Started	0: Do not output, 1: Output When the bit turns ON, the screen’s copying starts. <p><b>NOTE</b></p> <ul style="list-style-type: none"> <li>• When Status “Bit 2” (Printing) turns ON, please turn it OFF manually.</li> </ul>
	3	Reserved	0 Fixed
	4	Buzzer	The following action occurs only when Control “Bit 1” (Buzzer ON) is ON. 0: Sound, 1: Do not sound To stop the buzzer sound, turn this bit ON.
	5	AUX Output	The following action occurs only when Control “Bit 1” (Buzzer ON) is ON. 0: Sound, 1: Do not sound To stop the AUX output, turn this bit ON.
	6 to 10	Reserved	0 Fixed
	11	Print Cancelled	0: Output, 1: Do not output When the bit turns ON, all current printing is cancelled. <p><b>NOTE</b></p> <ul style="list-style-type: none"> <li>• After printing stops, when Status “Bit 2” (Printing) turns OFF, please turn it OFF manually.</li> <li>• Even when the Print Cancelled bit turns ON, data previously taken in by the printer’s memory will be printed.</li> </ul>
12 to 15	(Reserved)	0 Fixed	
Window Control	Controls the window display. ☞ “18.7.2 Word Action” (page 18-23)		
Window Screen No.	Stores the Global Window’s registration number selected by indirect designation. 1 to 2000 (BIN/BCD).		
Window Display Position	Stores the Global Window’s top-left display position, selected by indirect designation. “+18” shows the X coordinate, “+19” shows the Y coordinate. The data type is BIN or BCD.		

### A.1.4.3 Special Relay



The Special Relay is not write-protected. Do not turn it ON/OFF with Parts or write words.

The Special Relay has the following structure.

#### Direct Access Method

Address	Description
LS2032	Common Relay Information
LS2033	Base Screen Information
LS2034	Reserved
LS2035	1-Second Binary Counter
LS2036	Display Scan Time
LS2037	Communication Cycle Time
LS2038	Display Scan Counter
LS2039	Communication Error Code
LS2040	Reserved
LS2041	
LS2042	
LS2043	
LS2044	
LS2045	
LS2046	
LS2047	

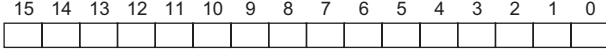
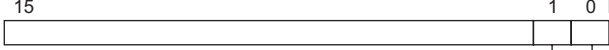
Description	Details																																		
<p>Common Relay Information (LS2032)</p>	<div style="text-align: center;"> <p>15 14 13 12 11 10 9 8 7 6 5 4 3 2 1 0 Bit</p>  </div> <table border="1" style="width: 100%; border-collapse: collapse;"> <thead> <tr> <th style="width: 5%;">Bit</th> <th>Description</th> </tr> </thead> <tbody> <tr> <td>0</td> <td>Repeats ON/OFF every communication cycle.</td> </tr> <tr> <td>1</td> <td>After a screen (Base, Window) changes, turns ON until communication with all the device addresses set in the screen has succeeded and the Part operation (process) has completed.</td> </tr> <tr> <td>2</td> <td>Turns ON only when a communication error occurs.</td> </tr> <tr> <td>3</td> <td>Turns ON while the initial screen is displayed at power ON.</td> </tr> <tr> <td>4</td> <td>Normally ON.</td> </tr> <tr> <td>5</td> <td>Normally OFF.</td> </tr> <tr> <td>6</td> <td>Turns ON when backup SRAM data is erased. (Only on-board backup SRAM)</td> </tr> <tr> <td>7</td> <td>When using D-Scripts, turns ON when a BCD error occurs.</td> </tr> <tr> <td>8</td> <td>When using D-Scripts, turns ON when a zero error occurs.</td> </tr> <tr> <td>9</td> <td>Turns ON when filing data could not be transferred to backup SRAM.</td> </tr> <tr> <td>10</td> <td>Turns ON when filing data transferred according to the Control Word Address could not be transferred from PLC to SRAM. Also, if transferring between the PLC by means of a Special Data Display, when there is a Transfer Completion Bit Address, turns ON when data could not be transferred from PLC to Area, or PLC to SRAM.</td> </tr> <tr> <td>11</td> <td>Turns ON while transferring filing data between SRAM and LS Area by mean of a Special Data Display (Filing).</td> </tr> <tr> <td>12</td> <td>When using D-Scripts, turns ON when a communication error occurs from a memcpy() or address offset designation read. Turns OFF when data finishes reading normally.</td> </tr> <tr> <td>13</td> <td>In [System Settings] - [Script Settings], when no [D-Script/Global D-Script] is set in the project, turns ON when the readout of the Send function, Receive function, Control, Status variable, and Received Data Size is executed in [SIO Port Operation]'s Label Settings.</td> </tr> <tr> <td>14</td> <td>In [System Settings] - [Script Settings], when [D-Script/Global D-Script] is set in the project, turns ON when an extended script's [Text Operation] function is executed. Also, in [System Settings] - [Script Settings], when [Extended Script] is set in the project, turns ON even when a D-Script/Global D-Script [SIO Port Operation]'s I/O function (IO_WRITE, IO_READ) is executed.</td> </tr> <tr> <td>15</td> <td>Reserved</td> </tr> </tbody> </table>	Bit	Description	0	Repeats ON/OFF every communication cycle.	1	After a screen (Base, Window) changes, turns ON until communication with all the device addresses set in the screen has succeeded and the Part operation (process) has completed.	2	Turns ON only when a communication error occurs.	3	Turns ON while the initial screen is displayed at power ON.	4	Normally ON.	5	Normally OFF.	6	Turns ON when backup SRAM data is erased. (Only on-board backup SRAM)	7	When using D-Scripts, turns ON when a BCD error occurs.	8	When using D-Scripts, turns ON when a zero error occurs.	9	Turns ON when filing data could not be transferred to backup SRAM.	10	Turns ON when filing data transferred according to the Control Word Address could not be transferred from PLC to SRAM. Also, if transferring between the PLC by means of a Special Data Display, when there is a Transfer Completion Bit Address, turns ON when data could not be transferred from PLC to Area, or PLC to SRAM.	11	Turns ON while transferring filing data between SRAM and LS Area by mean of a Special Data Display (Filing).	12	When using D-Scripts, turns ON when a communication error occurs from a memcpy() or address offset designation read. Turns OFF when data finishes reading normally.	13	In [System Settings] - [Script Settings], when no [D-Script/Global D-Script] is set in the project, turns ON when the readout of the Send function, Receive function, Control, Status variable, and Received Data Size is executed in [SIO Port Operation]'s Label Settings.	14	In [System Settings] - [Script Settings], when [D-Script/Global D-Script] is set in the project, turns ON when an extended script's [Text Operation] function is executed. Also, in [System Settings] - [Script Settings], when [Extended Script] is set in the project, turns ON even when a D-Script/Global D-Script [SIO Port Operation]'s I/O function (IO_WRITE, IO_READ) is executed.	15	Reserved
	Bit	Description																																	
	0	Repeats ON/OFF every communication cycle.																																	
	1	After a screen (Base, Window) changes, turns ON until communication with all the device addresses set in the screen has succeeded and the Part operation (process) has completed.																																	
	2	Turns ON only when a communication error occurs.																																	
	3	Turns ON while the initial screen is displayed at power ON.																																	
	4	Normally ON.																																	
	5	Normally OFF.																																	
	6	Turns ON when backup SRAM data is erased. (Only on-board backup SRAM)																																	
	7	When using D-Scripts, turns ON when a BCD error occurs.																																	
	8	When using D-Scripts, turns ON when a zero error occurs.																																	
	9	Turns ON when filing data could not be transferred to backup SRAM.																																	
	10	Turns ON when filing data transferred according to the Control Word Address could not be transferred from PLC to SRAM. Also, if transferring between the PLC by means of a Special Data Display, when there is a Transfer Completion Bit Address, turns ON when data could not be transferred from PLC to Area, or PLC to SRAM.																																	
	11	Turns ON while transferring filing data between SRAM and LS Area by mean of a Special Data Display (Filing).																																	
	12	When using D-Scripts, turns ON when a communication error occurs from a memcpy() or address offset designation read. Turns OFF when data finishes reading normally.																																	
13	In [System Settings] - [Script Settings], when no [D-Script/Global D-Script] is set in the project, turns ON when the readout of the Send function, Receive function, Control, Status variable, and Received Data Size is executed in [SIO Port Operation]'s Label Settings.																																		
14	In [System Settings] - [Script Settings], when [D-Script/Global D-Script] is set in the project, turns ON when an extended script's [Text Operation] function is executed. Also, in [System Settings] - [Script Settings], when [Extended Script] is set in the project, turns ON even when a D-Script/Global D-Script [SIO Port Operation]'s I/O function (IO_WRITE, IO_READ) is executed.																																		
15	Reserved																																		
<p>Base Screen Information (LS2033)</p>	<div style="text-align: center;"> <p>15 1 0 Bit</p>  </div> <p>This bit stays ON from the time the base screen changes until the communication with all device addresses set on the screen succeeds and the part actions are all handled.</p> <p>This bit toggles between ON/OFF each communication cycle of the base screen. LS2032's 0 bit turns ON/OFF with the same cycle.</p>																																		

Continued

Description	Details
Reserved (LS2034, LS2040 to LS2047)	The values of reserved addresses are undefined. Please do not use them.
1-Second Binary Counter (LS2035)	Increments once every second immediately after power is turned ON. The data is binary.
Display Scan Time (LS2036)	The display time taken starting from the first Part set on the display screen to the end of the last Part. Data is stored in binary format, in ms units. The data is updated when all processing for the target Parts has finished. The data's initial value is "0". There is an error of $\pm 10$ ms.
Communication Cycle Time (LS2037)	One cycle's time is from the start to the end of the management of the System Data Area allotted inside the device/PLC, and each type of device. Data is stored in binary format, in 10 ms units. The data is updated when all processing for the System Data Area and target device has finished. The data's initial value is "0". There is an error of $\pm 10$ ms. <b>NOTE</b> <ul style="list-style-type: none"> <li>When multiple devices/PLCs are connected to a single GP, the System Data Area can only be allotted to one device/PLC.</li> </ul>
Display Scan Counter (LS2038)	The counter increments each time the Part set on the display screen processes. The data is binary.
Communication Error Code (LS2039)	When a communication error occurs, this stores the last displayed communication error code in binary.

#### A.1.4.4 Device/PLC's System Data Area Allotment Procedure

When referencing a screen number displayed on the GP from a device/PLC or changing screens, to automatically reference/control the GP's data, share the GP's internal System Data Area's allotted data with the device/PLC.

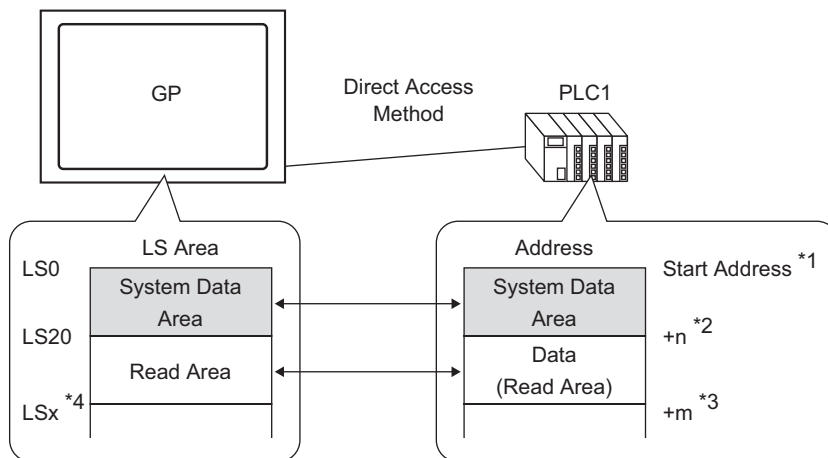

- \*1 Please set up the start address with the process mentioned on the next page.
- \*2  $n = 0$  to  $20$  This depends on the number of selected items in the GP's set System Data Area.
- \*3 This is the Read Area Size.
- \*4  $x = \text{Read Area Start Address } (20) + \text{Read Area Size } (m)$

#### IMPORTANT

- When multiple devices/PLCs are connected to a single GP, the System Data Area can only be allotted to one device/PLC.
- Please do not set addresses for Parts which span the System Data Area and Read Area, or the Read Area and User Area.
- When setting addresses for Parts in the System Data Area, please designate the data length as 16 bit.

#### NOTE

- The number of address that can be set in the System Data Area differs depending on the device/PLC. For details, please refer to "GP-Pro EX Device/PLC Connection Manual"

- 1 Select the [Project (F)] menu - [System Settings (C)] command, or click , and click the System Settings Window - [Main Unit Settings] - [System Area Settings] tab. The following screen will be displayed.

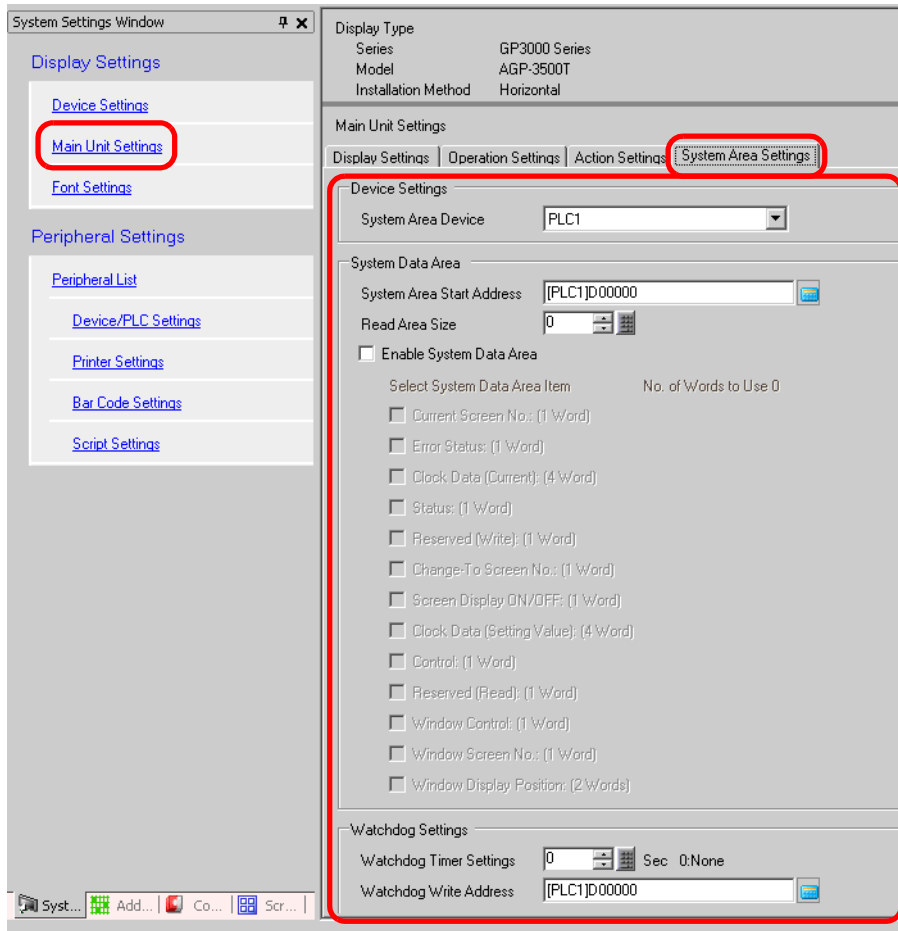

- 2 Allot the addresses in the device/PLC you will communicate with. In [System Area Device], select the device/PLC (e.g. “PLC1”) where you will allot addresses, and designate the start address of an area which can ensure 16 words or more of continuous addresses in [System Area Start Address]. (e.g. [PLC1]D00000)

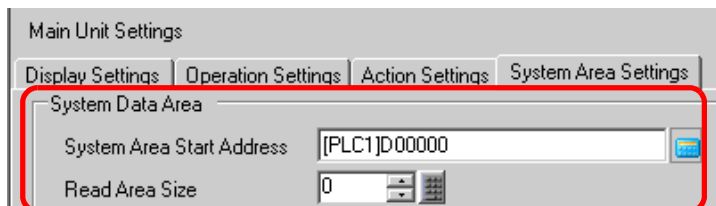

**NOTE** • Data used in all common screens and Line Charts’ block display data is stored in the “Read Area”. According to your needed capacity, you can designate a [Read Area Size] of up to 256 words. Use the LS area exclusively as the read area starting from the address on the right (e.g. [PLC1]D00000) and continuing for the designated number of words.

3 Put a check mark next to the [Enable System Data Area] box. 16 words will be automatically allotted starting from the start address.

☞ “A.1.5.2 System Data Area” (page A-23)

<input checked="" type="checkbox"/> Enable System Data Area	
Select System Data Area Item	No. of Words to Use 16
<input checked="" type="checkbox"/> Current Screen No.: (1 Word)	[PLC1]D00000
<input checked="" type="checkbox"/> Error Status: (1 Word)	[PLC1]D00001
<input checked="" type="checkbox"/> Clock Data (Current): (4 Word)	[PLC1]D00002
<input checked="" type="checkbox"/> Status: (1 Word)	[PLC1]D00006
<input checked="" type="checkbox"/> Reserved (Write): (1 Word)	[PLC1]D00007
<input checked="" type="checkbox"/> Change-To Screen No.: (1 Word)	[PLC1]D00008
<input checked="" type="checkbox"/> Screen Display ON/OFF: (1 Word)	[PLC1]D00009
<input checked="" type="checkbox"/> Clock Data (Setting Value): (4 Word)	[PLC1]D00010
<input checked="" type="checkbox"/> Control: (1 Word)	[PLC1]D00014
<input checked="" type="checkbox"/> Reserved (Read): (1 Word)	[PLC1]D00015
<input type="checkbox"/> Window Control: (1 Word)	
<input type="checkbox"/> Window Screen No.: (1 Word)	
<input type="checkbox"/> Window Display Position: (2 Words)	

---

**NOTE** • When using a Global Window, 4 words will be used for the [Window Control], [Window Screen No.], and [Window Display Position].

☞ “18.6 Changing the Displayed Window on All Screens” (page 18-17)

---

4 The settings are complete.

## A.1.5 System Area (Memory Link Area)

When communicating inside the GP by Memory Link Method, the System Area is secured. This area is used for exchanging with the host.

### A.1.5.1 System Area List

<Memory Link Method System Area>

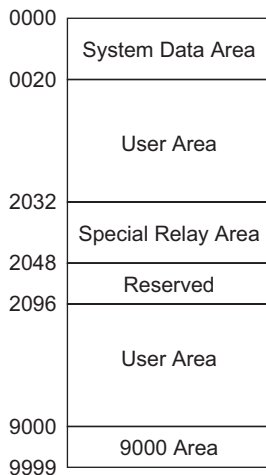

**IMPORTANT**

- Please do not set addresses for Parts which span the System Data Area and Read Area, or the Read Area and User Area.
- When setting addresses for Parts in the System Data Area, please designate the data length as 16 bit.

Area Name	Description
System Data Area	This area stores data necessary for the system's operation, such as the GP's screen control data and error information. The write contents are decided. ☞ "A.1.5.2 System Data Area" (page A-23)
User Area	This area is used for exchanging data between the GP and host (computer, etc.). On the host, decide which GP address data to write, and create a program to write the data. In the GP, configure settings for special Parts in order to display data written in the addresses. In order for the host to read written data by means of Switches, Data Displays, and keypads, you need to create a program in the host to read the GP's data.
Special Relay	This area stores each type of status information that occurs when the GP communicates. ☞ "A.1.5.3 Special Relay" (page A-30)
Reserved	Used inside the GP. Please do not use this area. Otherwise, it will not function normally.
9000 Area	Stores the GP's internal operating information such as a Trend Graph's historical data and the communication scan time. There is also an adjustable portion.

- NOTE** • When the address has a bit designation, add a bit position after the word device. (Designate from 00 to 15.)

(e.g.) When bit 02 of the user area's 0020 address is designated

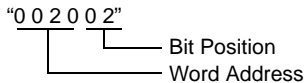

### A.1.5.2 System Data Area

This shows the contents of write data in each address of the System Data Area.

- IMPORTANT** • Normally, when turning OFF the Screen Display, do not use 11 (Control)'s "Backlight OFF" bit, please use 12 (Screen Display ON/OFF).

- NOTE** • The "Word Addresses" in this table are the values which would appear if you put a check mark next to the [Enable System Data Area] box and selected all of the items.

Word Address	Description	Bit	Details
0	Reserved	—	Reserved
1	Status	0 to 1	Reserved
		2	Printing
		3	Data Display Part Write Setting Value
		4 to 7	Reserved
		8	Data Display Part Input Error
		9	Display ON/OFF 0:ON, 1:OFF
		10	Expired backlight detected
		11 to 15	Reserved
2	Reserved	—	Reserved
3	Error Status	0 to 2	Unused
		3	Screen Memory Check Sum
		4	SIO Framing
		5	SIO Parity
		6	SIO Overrun
		7 to 9	Unused
		10	Backup Battery Low Voltage
		11 to 15	Unused
4	Clock's current "Year" value	0 to 7	Last 2 digits of year ( 2 BCD digits)
		8 to 15	Unused
5	Clock's current "Month" value	0 to 7	01 to 12 (2 BCD digits)
		8 to 15	Unused
6	Clock's current "Day" value	0 to 7	01 to 31 (2 BCD digits)
		8 to 15	Unused



Continued

Word Address	Description	Bit	Details
7	Clock's current "Hour" value	0 to 7	00 to 23 (2 BCD digits)
		8 to 15	Unused
8	Clock's current "Minute" value	07	00 to 59 (2 BCD digits)
		8 to 15	Unused
9	Reserved	—	Reserved
10	Interrupt Output (When touch is OFF)	—	If writing to a Word Switch (16 bit), when you take your finger off the Switch, the lower 8 bits get outputted as an interrupt code.*1
11	Control	0	Backlight OFF
		1	Buzzer ON
		2	Print Started
		3	Reserved
		4	Buzzer
		5	AUX Output
		6	Writes "FFh" when you touch a screen and return to the screen (from "Display OFF" to "Display ON"). 0: Do not output interrupt 1: Output interrupt
		7 to 10	Reserved
		11	Print Cancelled
12 to 15	Reserved		
12	Screen Display ON/OFF	—	Turn Screen Display OFF with FFFFh Display screen with 0h
13	Interrupt Output (When touch is ON)	—	When writing to a Word Switch (16 bit), the lower 8 bits get outputted as an interrupt code.*1
14	Reserved	—	Reserved
15	Change - To Screen No.	—	When applying "Change - To Screen No." to Device/PLC 1 to 9999 (BIN), or 1 to 7999 (BCD).
16	Window Control	0	Show Window 0: OFF, 1:ON
		1	Change Window overlap order 0: Permitted, 1: Not permitted
		12 to 15	Reserved
17	Window Screen No.	—	Global Window's registration number selected by indirect designation 1 to 2000 (BIN/BCD).
18	Window Display Position (X Coordinate)	—	Global Window's top-left display position, selected by indirect designation (BIN/BCD).
19	Window Display Position (Y Coordinate)	—	

\*1 If you write over data from 0x00 to 0x1F there may be some damage to communications.

Description	Details		
Reserved	Addresses “0”, “2”, “9”, and “14” are reserved.  Because they are used within the GP, please do not write data to them. Otherwise, they will not function properly.		
Status	Please monitor only the necessary bits. “Reserved” bits are sometimes used for maintenance of the GP’s system so please do NOT turn them ON/OFF.		
	Bit	Description	Details
	0,1	Reserved	—
	2	Printing	Turns ON during printing. While this bit is ON, output may be corrupted if the screen changes to the offline screen.
	3	Write Setting Value	This bit is reversed each time a write occurs from a Data Display (Setting Value Input).
	4 to 7	Reserved	—
	8	Data Display Part Input Error	When Alarm Settings are set on the Data Display where you are currently inputting and you input a value outside of the alarm range, this bit turns ON. When you input a value inside the alarm range or change screens, this bit turns OFF.
	9	Display ON/OFF (0: ON, 1: OFF)	This can detect whether to turn the GP’s screen display ON/OFF from the device/PLC. This bit will change in the following cases. (1) When FFFFh is written to the System Data Area’s Display ON/OFF, the display turns OFF. (2) When the standby time passes, the display will automatically turn OFF (3) If the screen changes or is touched after the display turns OFF, the display will turn back ON. <div style="border: 1px solid black; padding: 2px; width: fit-content; margin-top: 10px;"><b>NOTE</b></div> <ul style="list-style-type: none"> <li>• This bit cannot change LS0014 “Control”’s 0 bit (Backlight OFF).</li> </ul>
10	Expired backlight detected	When an expired backlight is detected, this bit turns ON.	
11 to 15	Reserved	—	

Continued

Description	Details		
Error Status	When an error occurs in the GP, the corresponding bit turns ON. After the bit turns ON and the power turns OFF, the status is maintained until it changes from offline mode back to active mode.		
	Bit	Description	Details
	0 to 2	Unused	
	3	Screen Memory Check Sum	There is an error in the project file. Please transfer it again.
	4	SIO Framing	
	5	SIO Parity	
	6	SIO Overrun	
	7 to 9	Unused	
	10	Backup Battery Low Voltage	This turns ON when the voltage of the backup lithium battery is low. The backup battery is used by the clock and SRAM.
11 to 15	Unused		
 Because the addresses are used for system control, please do not display them by means of a Data Display.			
Clock Data (Current)	<p>Whatever the value, it will be stored in BCD, in the highest-order bit to bit 7.                      [Year] is the 2 final digits of the year, [Month] is 2 digits from 01 to 12, [Day] is 2 digits from 01 to 31, [Hour] is 2 hour digits from 00 to 23 and [Minute] is 2 minute digits from 00 to 59.</p> <p>■ Setting Example: October 19th, 2005, 21:57                      “Year” - Write “0005” to Word Address “4”                      “Month” - Write “0010” to Word Address “5”                      “Day” - Write “0019” to Word Address “6”                      “Hour” - Write “0021” to Word Address “7”                      “Minute” - Write “0057” to Word Address “8”</p>		
Interrupt Output (When touch is OFF)	<p>If writing to a Word Switch (16 bit), when you take your finger off the Switch, the lower 8 bits get outputted as an interrupt code. (Control code “FFh” will not be outputted.)</p> <p> Please do not write control codes in the 00 to 1F range. It can cause a communication problem.</p>		





Continued

Description	Details		
Control	<p><b>NOTE</b></p> <ul style="list-style-type: none"> <li>• Please make sure to write this address in bit units. In some cases, writing with word data will change the value.</li> <li>• “Reserved” bits are sometimes used for maintenance of the GP’s system so please turn them OFF.</li> </ul>		
	Bit	Description	Details
	0	Backlight OFF	When ON, the backlight turns OFF, when OFF, the backlight turns ON. (The parts placed on the screen will still function after the LCD is lit.) <b>NOTE</b> • Normally, when turning OFF the screen display, please use Word Address “12” (Screen Display ON/OFF).
	1	Buzzer ON	0: Do not sound, 1: Sound
	2	Print Started	0: Do not sound, 1: Sound When the bit turns ON, the screen’s copying starts. <b>NOTE</b> • When Status “Bit 2” (Printing) turns ON, please turn it OFF manually.
	3	Reserved	0 Fixed
	4	Buzzer	The following action occurs only when Control “Bit 1” (Buzzer ON) is ON. 0: Sound, 1: Do not sound To stop the buzzer sound, turn this bit ON.
	5	AUX Output	The following action occurs only when Control “Bit 1” (Buzzer ON) is ON. 0: Sound, 1: Do not sound To stop the AUX output, turn this bit ON.
	6	Interrupt output for when a screen is changed from OFF to ON by touching a touch panel	(Interrupt code: FFh) 0: Do not output interrupt, 1: Output interrupt
	7 to 10	Reserved	0 Fixed
	11	Print Cancelled	0: Sound, 1: Do not sound When the bit turns ON, all current printing is cancelled. <b>NOTE</b> • After printing stops, when Status “Bit 2” (Printing) turns OFF, please turn it OFF manually. • Even when the Print Cancelled bit turns ON, data previously taken in by the printer’s memory will be printed.
	12 to 15	(Reserved)	0 Fixed

Continued

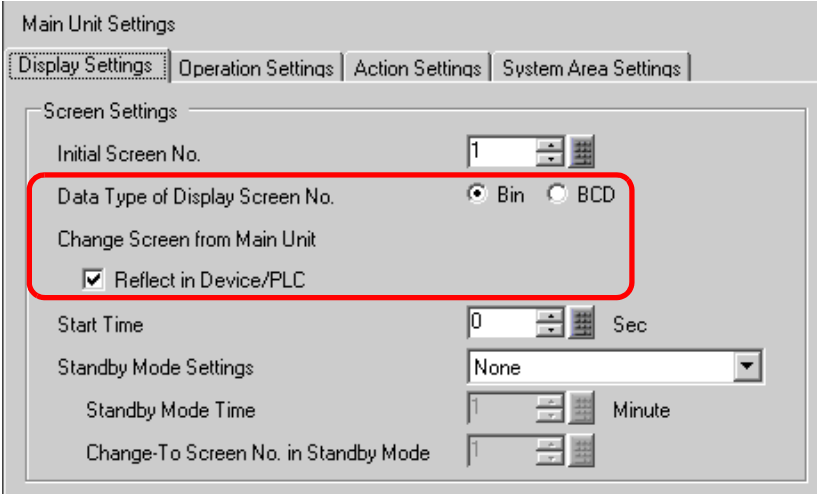
Description	Details
Screen Display ON/ OFF	<p>Displays when the value is “0h”, hides the screen when the value is “FFFFh”. Values other than “0h” and “FFFFh” are reserved. When the screen display is hidden (when the value becomes “FFFFh”), the next touch on the screen will turn the display back ON.</p> <ul style="list-style-type: none"> <li>⊘ Because the addresses are used for system control, please do not display them by means of a Data Display.</li> <li>⊘ Because the addresses are controlled in word units, you cannot write bits.</li> <li>⊘ When you write “FFFFh”, the displayed screen disappears momentarily. If you want the screen display to disappear for the standby mode time designated in the GP offline mode’s initial settings, please write “0000h”.</li> </ul>
Interrupt Output (When touch is ON)	<p>When writing to a Word Switch (16 bit), the lower 8 bits get outputted from the GP to the host as an interrupt code.</p> <ul style="list-style-type: none"> <li>⊘ Please do not write control codes in the 00 to 1F range. It can cause a communication problem.</li> <li>⊘ Because the addresses are used for system control, please do not display them by means of a Data Display.</li> <li>⊘ Because the addresses are controlled in word units, you cannot write bits.</li> </ul> <p><b>NOTE</b></p> <ul style="list-style-type: none"> <li>• When you write data with a Word Switch (16 bit), it will be outputted as interrupt data. Retrieve this byte of interrupt input in the host (with the INPUT\$ in BASIC, for example), and you can simplify the program by using the retrieved interrupt output to jump to each subroutine.</li> </ul>

Continued

Description	Details																		
<p>Change - To Screen No.</p>	<p>Set the Change-to Screen No. The setting range differs depending on whether or not [Data Type of Display Screen No.] and [Change Screen from Main Unit - Reflect in Device/PLC] are set on the System Settings - [Main Unit Settings] - [Display Settings] tab.</p>  <p>When [Data Type of Display Screen No.] is [BIN]</p> <table border="1" data-bbox="399 896 1171 1027"> <thead> <tr> <th>Reflect in Device/PLC</th> <th>Screen Change from Device/PLC</th> <th>Screen Change from Main Unit (Switch, etc.)</th> </tr> </thead> <tbody> <tr> <td>Checked</td> <td>1 to 9999</td> <td>1 to 9999</td> </tr> <tr> <td>Unchecked</td> <td>1 to 9999</td> <td>1 to 9999</td> </tr> </tbody> </table> <p>When [Data Type of Display Screen No.] is [BCD]</p> <table border="1" data-bbox="399 1097 1171 1228"> <thead> <tr> <th>Reflect in Device/PLC</th> <th>Screen Change from Device/PLC</th> <th>Screen Change from Main Unit (Switch, etc.)</th> </tr> </thead> <tbody> <tr> <td>Checked</td> <td>1 to 7999</td> <td>1 to 7999</td> </tr> <tr> <td>Unchecked</td> <td>1 to 1999</td> <td>1 to 7999</td> </tr> </tbody> </table> <ul style="list-style-type: none"> <li> Because the addresses are used for system control, please do not display them by means of a Data Display.</li> <li> Because the addresses are controlled in word units, you cannot write bits.</li> </ul>	Reflect in Device/PLC	Screen Change from Device/PLC	Screen Change from Main Unit (Switch, etc.)	Checked	1 to 9999	1 to 9999	Unchecked	1 to 9999	1 to 9999	Reflect in Device/PLC	Screen Change from Device/PLC	Screen Change from Main Unit (Switch, etc.)	Checked	1 to 7999	1 to 7999	Unchecked	1 to 1999	1 to 7999
Reflect in Device/PLC	Screen Change from Device/PLC	Screen Change from Main Unit (Switch, etc.)																	
Checked	1 to 9999	1 to 9999																	
Unchecked	1 to 9999	1 to 9999																	
Reflect in Device/PLC	Screen Change from Device/PLC	Screen Change from Main Unit (Switch, etc.)																	
Checked	1 to 7999	1 to 7999																	
Unchecked	1 to 1999	1 to 7999																	
<p>Window Control</p>	<p>Controls the window display.   "18.7.2 Word Action" (page 18-23)</p>																		
<p>Window Screen No.</p>	<p>Stores the Global Window's registration number selected by indirect designation. 1 to 2000 (BIN/BCD).</p>																		
<p>Window Display Position</p>	<p>Stores the Global Window's top-left display position, selected by indirect designation. "+18" shows the X coordinate, "+19" shows the Y coordinate. The data type is BIN or BCD.</p>																		

### A.1.5.3 Special Relay





The Special Relay is not write-protected. Do not turn it ON/OFF with Parts or write words.

The Special Relay has the following structure.

#### Memory Link Method

Address	Description
2032	Common Relay Information
2033	Base Screen Information
2034	Reserved
2035	1-Second Binary Counter
2036	Display Scan Time
2037	Reserved
2038	Display Scan Counter
2039	Reserved
2040	Reserved
2041	
2042	
2043	
2044	
2045	
2046	
2047	

Description	Details																																		
Common Relay Information (2032)	<div style="text-align: center;">                         15 14 13 12 11 10 9 8 7 6 5 4 3 2 1 0 Bit   </div> <table border="1" style="width: 100%; border-collapse: collapse;"> <thead> <tr> <th style="width: 5%;">Bit</th> <th style="width: 95%;">Description</th> </tr> </thead> <tbody> <tr> <td>0</td> <td>Reserved</td> </tr> <tr> <td>1</td> <td>After a screen (Base, Window) changes, turns ON until the Part handling is complete.</td> </tr> <tr> <td>2</td> <td>Reserved</td> </tr> <tr> <td>3</td> <td>Turns ON while the initial screen is displayed at power ON.</td> </tr> <tr> <td>4</td> <td>Normally ON.</td> </tr> <tr> <td>5</td> <td>Normally OFF.</td> </tr> <tr> <td>6</td> <td>Turns ON when backup SRAM data is erased. (Only on-board backup SRAM)</td> </tr> <tr> <td>7</td> <td>When using D-Scripts, turns ON when a BCD error occurs.</td> </tr> <tr> <td>8</td> <td>When using D-Scripts, turns ON when a zero error occurs.</td> </tr> <tr> <td>9</td> <td>Turns ON when filing data could not be transferred to backup SRAM.</td> </tr> <tr> <td>10</td> <td>Turns ON when filing data transferred according to the Control Word Address could not be transferred from PLC*1 to SRAM. Also, if transferring between the PLC by means of a Special Data Display, when there is a Transfer Completion Bit Address, turns ON when data could not be transferred from PLC*1 to Area, or PLC*1 to SRAM.</td> </tr> <tr> <td>11</td> <td>Turns ON while transferring filing data between SRAM and LS Area*1 by mean of a Special Data Display (Filing).</td> </tr> <tr> <td>12</td> <td>When using D-Scripts, turns ON when a communication error occurs from a memcpy() or address offset designation read. Turns OFF when data finishes reading normally.</td> </tr> <tr> <td>13</td> <td>In [System Settings] - [Script Settings], when no [D-Script/Global D-Script] is set in the project, turns ON when the readout of the Send function, Receive function, Control, Status variable, and Received Data Size is executed in [SIO Port Operation]'s Label Settings.</td> </tr> <tr> <td>14</td> <td>In [System Settings] - [Script Settings], when [D-Script/Global D-Script] is set in the project, turns ON when an extended script's [Text Operation] function is executed. Also, in [System Settings] - [Script Settings], when [Extended Script] is set in the project, turns ON even when a D-Script/Global D-Script [SIO Port Operation]'s I/O function (IO_WRITE, IO_READ) is executed.</td> </tr> <tr> <td>15</td> <td>Reserved</td> </tr> </tbody> </table> <p>*1 For the Memory Link Method, represents the "User Area" inside the System Area.</p>	Bit	Description	0	Reserved	1	After a screen (Base, Window) changes, turns ON until the Part handling is complete.	2	Reserved	3	Turns ON while the initial screen is displayed at power ON.	4	Normally ON.	5	Normally OFF.	6	Turns ON when backup SRAM data is erased. (Only on-board backup SRAM)	7	When using D-Scripts, turns ON when a BCD error occurs.	8	When using D-Scripts, turns ON when a zero error occurs.	9	Turns ON when filing data could not be transferred to backup SRAM.	10	Turns ON when filing data transferred according to the Control Word Address could not be transferred from PLC*1 to SRAM. Also, if transferring between the PLC by means of a Special Data Display, when there is a Transfer Completion Bit Address, turns ON when data could not be transferred from PLC*1 to Area, or PLC*1 to SRAM.	11	Turns ON while transferring filing data between SRAM and LS Area*1 by mean of a Special Data Display (Filing).	12	When using D-Scripts, turns ON when a communication error occurs from a memcpy() or address offset designation read. Turns OFF when data finishes reading normally.	13	In [System Settings] - [Script Settings], when no [D-Script/Global D-Script] is set in the project, turns ON when the readout of the Send function, Receive function, Control, Status variable, and Received Data Size is executed in [SIO Port Operation]'s Label Settings.	14	In [System Settings] - [Script Settings], when [D-Script/Global D-Script] is set in the project, turns ON when an extended script's [Text Operation] function is executed. Also, in [System Settings] - [Script Settings], when [Extended Script] is set in the project, turns ON even when a D-Script/Global D-Script [SIO Port Operation]'s I/O function (IO_WRITE, IO_READ) is executed.	15	Reserved
	Bit	Description																																	
0	Reserved																																		
1	After a screen (Base, Window) changes, turns ON until the Part handling is complete.																																		
2	Reserved																																		
3	Turns ON while the initial screen is displayed at power ON.																																		
4	Normally ON.																																		
5	Normally OFF.																																		
6	Turns ON when backup SRAM data is erased. (Only on-board backup SRAM)																																		
7	When using D-Scripts, turns ON when a BCD error occurs.																																		
8	When using D-Scripts, turns ON when a zero error occurs.																																		
9	Turns ON when filing data could not be transferred to backup SRAM.																																		
10	Turns ON when filing data transferred according to the Control Word Address could not be transferred from PLC*1 to SRAM. Also, if transferring between the PLC by means of a Special Data Display, when there is a Transfer Completion Bit Address, turns ON when data could not be transferred from PLC*1 to Area, or PLC*1 to SRAM.																																		
11	Turns ON while transferring filing data between SRAM and LS Area*1 by mean of a Special Data Display (Filing).																																		
12	When using D-Scripts, turns ON when a communication error occurs from a memcpy() or address offset designation read. Turns OFF when data finishes reading normally.																																		
13	In [System Settings] - [Script Settings], when no [D-Script/Global D-Script] is set in the project, turns ON when the readout of the Send function, Receive function, Control, Status variable, and Received Data Size is executed in [SIO Port Operation]'s Label Settings.																																		
14	In [System Settings] - [Script Settings], when [D-Script/Global D-Script] is set in the project, turns ON when an extended script's [Text Operation] function is executed. Also, in [System Settings] - [Script Settings], when [Extended Script] is set in the project, turns ON even when a D-Script/Global D-Script [SIO Port Operation]'s I/O function (IO_WRITE, IO_READ) is executed.																																		
15	Reserved																																		
Base Screen Information (2033)	<div style="text-align: center;">                         15 <span style="float: right;">1 0 Bit</span>   </div> <p style="text-align: center;">This bit stays ON from the time the base screen changes until handling of all parts is complete.</p> <p style="text-align: right;">Reserved</p>																																		
Reserved (2034, 2037, 2040 to 2047)	The values of reserved addresses are undefined. Please do not use them.																																		

Continued

Description	Details
1-Second Binary Counter (2035)	Increments once every second immediately after power is turned ON. The data is binary.
Display Scan Time (2036)	The display time taken starting from the first Part set on the display screen to the end of the last Part. Data is stored in binary format, in ms units. The data is updated when the targeted Parts' preprocessing is complete. The data's initial value is "0". There is an error of $\pm 10$ ms.
Display Scan Counter (2038)	The counter increments each time the Part set on the display screen processes. The data is binary.

## A.1.6 Restrictions

---

### A.1.6.1 GP Internal Device Restrictions

---

- Data stored in the GP's internal device (including Memory Link's System Area) will be deleted when the GP enters offline mode (by turning OFF the GP's power, by transferring, etc.). However, you can copy the User Area's data to backup SRAM.
  - ☞ "6.13.6 [System Settings Window] Setting Guide ■ [Main Unit Settings] Settings Guide
    - Backup Internal Device" (page 6-103)

---

### A.1.6.2 Special Relay Restrictions

---

- ⊘ A System Error may occur if a communication error continues for a long time, due to a communication cable coming loose, etc. In this case, please reset the GP again.
  
- ⊘ When you use the value of a 1-Second Binary Counter or Display Scan Counter as the trigger bit for a Trigger Action part's Monitoring Bit or for the Script feature, a System Error may occur if a communication error continues for a long time. In this case, please reset the GP again.
  
- ⚠ The Special Relay is not write-protected. Do not turn it ON/OFF with Parts or write words.

### A.1.6.3 Restrictions when Using Direct Access and Memory Link Together

<When using both the Direct Access Method and the Memory Link Method, and communicating with a device/PLC>

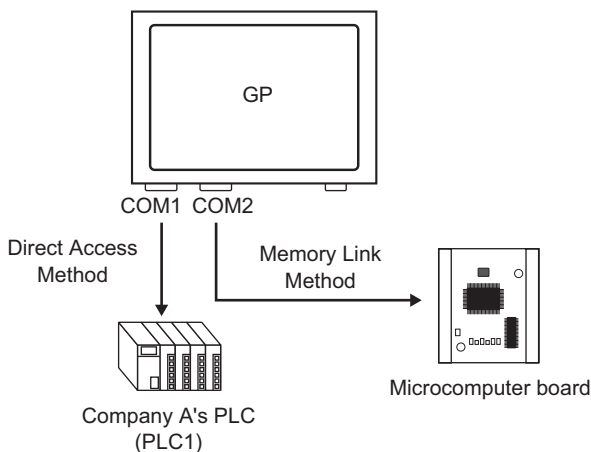

- When setting addresses with Parts or the Script feature, please separate them in the GP internal device.  
For example, when setting a word switch's [Word Address], you can select 2 types of device code when you use the GP internal device, but the supported communication method differs depending on the area.

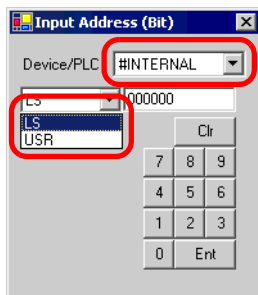

- [#INTERNAL]LS  
The User Area allocated in the Device/PLC with the Direct Access Method.
- [#INTERNAL]USR  
An area that can be arbitrarily set as a work area. Can be used with both the Direct Access Method and Memory Link Method.
- [#MEMLINK]  
The User Area used only for communication by Memory Link Method. You cannot use the Direct Access Method to communicate.



- With the exception of some addresses, the Direct Access Method's LS Area and the Memory Link Method's LS Area (System Area) are mutually linked.

	Direct Access Method LS Area		Memory Link Method LS Area	
LS0000	System Data Area	Partly Linked	System Data Area	0000
LS0020	Read Area			0020
(LS0276)	User Area		User Area	
LS2032	Special Relay Area	Linked	Special Relay Area	2032
LS2048	Reserved Area	Linked	Reserved Area	2048
LS2096	User Area		User Area	2096
LS8192	User Area		User Area	8192
LS9000	LS9000 Area	Linked	LS9000 Area	9000
LS9999				9999

- The “System Data Area” is partly linked, as shown in the above image. Please confirm the details in the corresponding table.

Description	Direct Access Method Address	Memory Link Method Address
Current Screen No.	LS0000	0015 (Read)
Error Status	LS0001	0003
Clock data’s current value (Year)	LS0002	0004 (Read)
Clock data’s current value (Month)	LS0003	0005 (Read)
Clock data’s current value (Day)	LS0004	0006 (Read)
Clock data’s current value (Time)	LS0005	0007, 0008 (Read)
Status	LS0006	0001
(Reserved)	LS0007	None
Change - To Screen No.	LS0008	0015 (Write)
Screen Display ON/OFF	LS0009	0012
Clock data’s setting value (Year)	LS0010	0004 (Write)
Clock data’s setting value (Month)	LS0011	0005 (Write)
Clock data’s setting value (Day)	LS0012	0006 (Write)
Clock data’s setting value (Time)	LS0013	0007, 0008 (Write)
Control	LS0014	0011
(Reserved)	LS0015	None
Window Control	LS0016	0016
Window Screen No.	LS0017	0017
Window Display Position (X Coordinate)	LS0018	0018
Window Display Position (Y Coordinate)	LS0019	0019
Interrupt Output Data (When touch is OFF)	None	0010
Interrupt Output Data (When touch is ON)	None	0013

**NOTE**

- Some LS areas communicate with the device/PLC. For example, if “Change - To Screen No.” is changed to 3 (Memory Link Method address 0015) from a microcomputer board or other host, 3 will also be stored in Direct Access Method address LS0008, linked within GP. Make sure the LS areas’ operation will not be affected by these changes.

### A.1.6.4 Restrictions when Using the USR Area

- The storage order for text data is as follows. You cannot change the order.

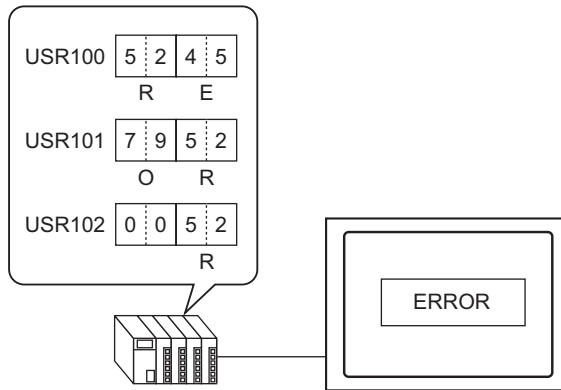

## A.2 Executing Multiple Actions (Programs) with a Switch Operation

### A.2.1 Trigger Action Settings Guide

#### ■ Bit Action

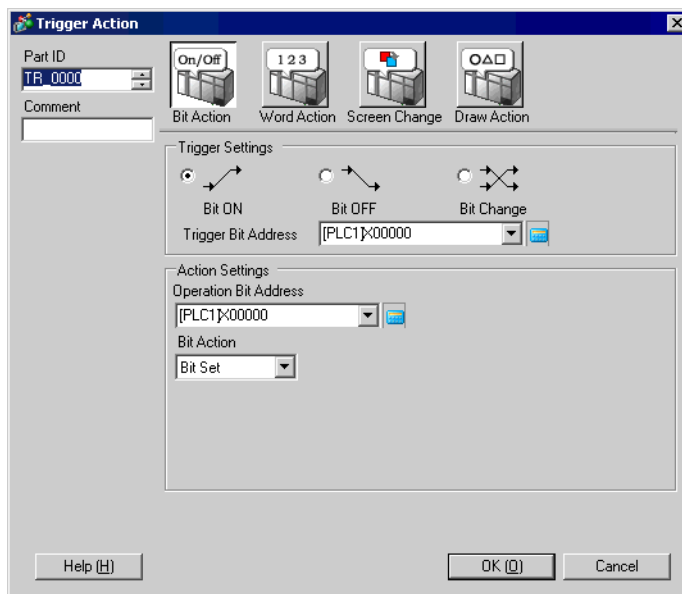

Setting		Description
Trigger Settings	Bit ON	Executes the action designated in [Action Settings] when the [Trigger Bit Address] changes from OFF to ON.
	Bit OFF	Executes the action designated in [Action Settings] when the [Trigger Bit Address] changes from ON to OFF.
	Bit Change	Executes the action designated in [Action Settings] when the [Trigger Bit Address] changes from ON to OFF or from OFF to ON.
	Trigger Bit Address	Designate the bit address which will trigger the action designated in [Action Settings].
Action Settings	Operation Bit Address	Designate the bit address to run the action.

Continued

	Setting	Description												
Action Settings	Bit Action	<p>Bit Set Turns ON the [Operation Bit Address] and maintains the ON state.</p> <p>Bit Reset Turns OFF the [Operation Bit Address] and maintains the OFF state.</p> <p>Bit Invert Changes the ON/OFF state of the [Operation Bit Address].</p> <p>Comparison When the comparison condition is satisfied, turns ON the [Operation Bit Address]. Compares the Word Address data and a constant.</p> <div data-bbox="469 533 1171 683" style="border: 1px solid gray; padding: 5px; margin: 10px 0;"> <table style="width: 100%; border-collapse: collapse;"> <tr> <td style="border-bottom: 1px solid gray; width: 40%;">Comparison Word Address</td> <td style="border-bottom: 1px solid gray; width: 20%;">Comparison Condition</td> <td style="border-bottom: 1px solid gray; width: 40%;">Constant</td> </tr> <tr> <td style="border-bottom: 1px solid gray;">[PLC1]D00000</td> <td style="border-bottom: 1px solid gray;">&lt;=</td> <td style="border-bottom: 1px solid gray;">300</td> </tr> <tr> <td colspan="2"></td> <td style="border-bottom: 1px solid gray;">Data Type</td> </tr> <tr> <td colspan="2" style="text-align: center;">D00000 &lt;= 300</td> <td style="border-bottom: 1px solid gray;">Dec</td> </tr> </table> </div> <ul style="list-style-type: none"> <li>• Comparison Word Address Designate the Word Address to be compared.</li> <li>• Comparison Condition Select the comparison condition.</li> <li>• Constant Designate the constant to be compared.</li> <li>• Data Type Designate the constant's data type.</li> </ul>	Comparison Word Address	Comparison Condition	Constant	[PLC1]D00000	<=	300			Data Type	D00000 <= 300		Dec
Comparison Word Address	Comparison Condition	Constant												
[PLC1]D00000	<=	300												
		Data Type												
D00000 <= 300		Dec												

■ Word Action

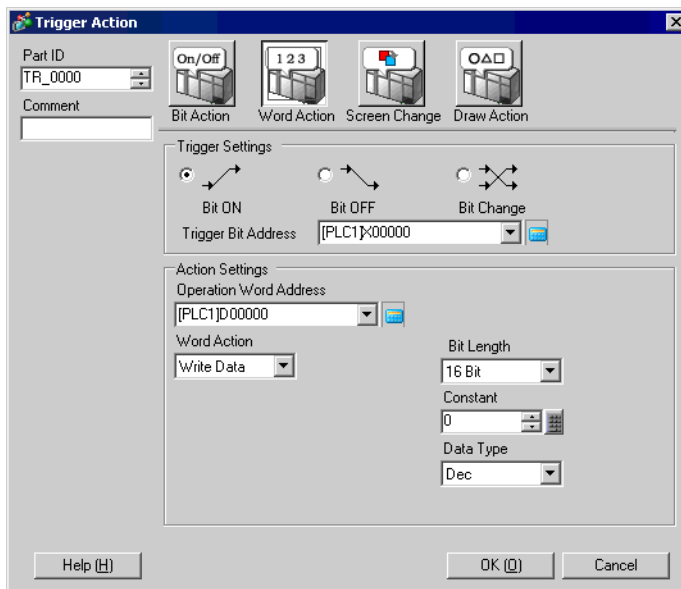

Setting		Description
Trigger Settings	Bit ON	Executes the action designated in [Action Settings] when the [Trigger Bit Address] changes from OFF to ON.
	Bit OFF	Executes the action designated in [Action Settings] when the [Trigger Bit Address] changes from ON to OFF.
	Bit Change	Executes the action designated in [Action Settings] when the [Trigger Bit Address] changes from ON to OFF or from OFF to ON.
	Trigger Bit Address	Designate the bit address which will trigger the action designated in [Action Settings].
Action Settings	Operation Word Address	Designate the word address to run the action.

Continued



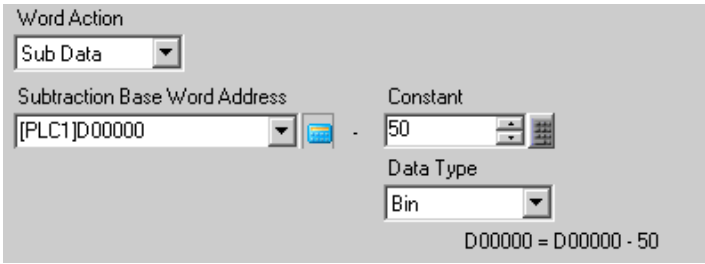

Setting		Description
Action Settings	Word Action	<p>Sub Data Writes the value of the [Subtraction Base Word Address] minus the constant into the [Operation Word Address].</p>  <ul style="list-style-type: none"> <li>• Subtraction Base Word Address Designate the Word Address the constant will be subtracted from.</li> <li>• Constant Designate the constant to subtract.</li> <li>• Data Type Designate the constant's data type.</li> </ul>

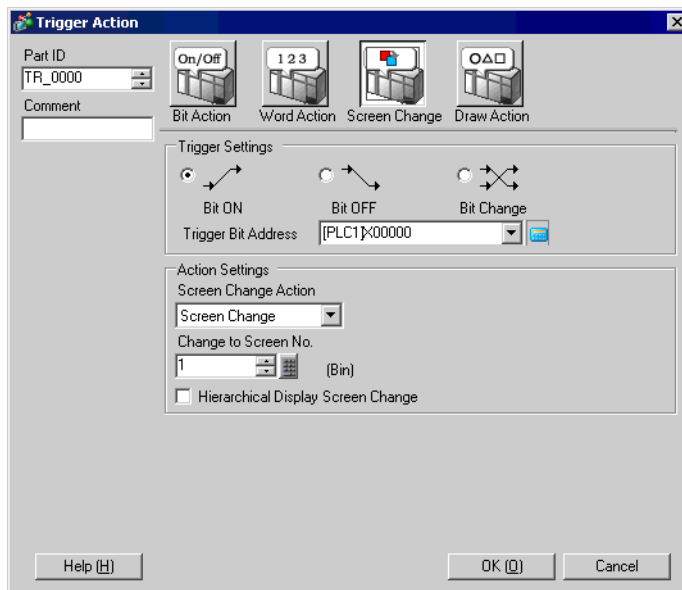
■ Screen Change

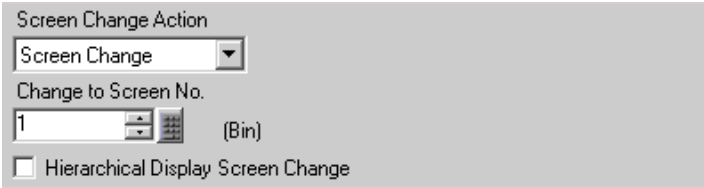

Setting		Description
Trigger Settings	Bit ON	Executes the action designated in [Action Settings] when the [Trigger Bit Address] changes from OFF to ON.
	Bit OFF	Executes the action designated in [Action Settings] when the [Trigger Bit Address] changes from ON to OFF.
	Bit Change	Executes the action designated in [Action Settings] when the [Trigger Bit Address] changes from ON to OFF or from OFF to ON.
	Trigger Bit Address	Designate the bit address which will trigger the action designated in [Action Settings].

Continued

Setting		Description
Action Settings	Screen Change Action	<p><b>Screen Change</b> The displayed screen changes (jumps) to the specified screen.</p>  <ul style="list-style-type: none"> <li>• <b>Change to Screen No.</b> Specify the number of the Screen you want to display from 1 to 9,999. This can only be set when [Screen Change Action] is set to [Screen Change].</li> <li>• <b>Hierarchical Display Screen Change</b> You can set a level hierarchy to the Screen Change. This can only be set when [Screen Change Action] is set to [Screen Change]. A maximum of 32 levels can be set.</li> </ul> <p><b>Previous Screen</b> Returns to the previously displayed screen. For screens that are organized hierarchically, the screen one level up (the parent screen) will reappear.</p> 

■ Draw Action

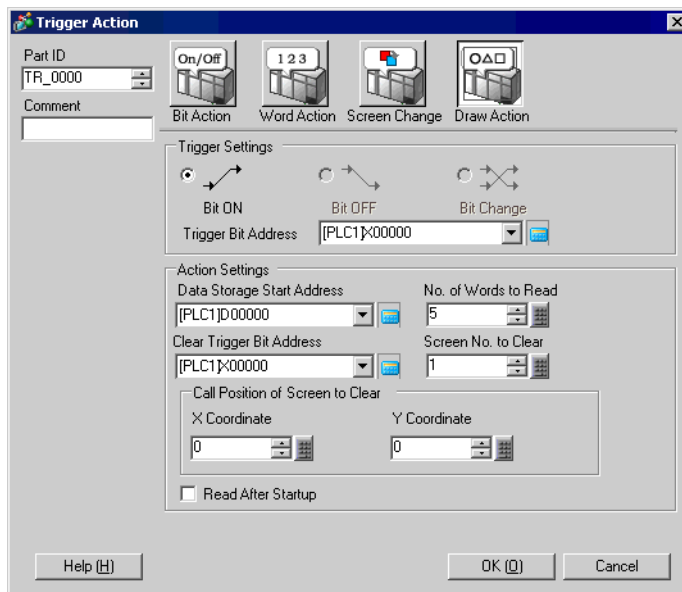

Setting		Description
Trigger Settings	Bit ON	Executes the action designated in [Action Settings] when the [Trigger Bit Address] changes from OFF to ON.
	Trigger bit Address	Select the bit address which will trigger the drawing of the image. <div style="border: 1px solid black; padding: 2px; display: inline-block;"><b>NOTE</b></div> <ul style="list-style-type: none"> <li>When the image displays, this will automatically turn OFF.</li> <li>Please maintain graphical data while drawing.</li> </ul>

Setting		Description
Action Settings	Data Storage Start Address	Stores the image and properties as graphical data in a word address. Designate this word address' start address. ☞ “ ■ Graphical Data” (page A-47)
	No. of Words to Read	Designate the number of words of graphical data. ☞ “ ■ Graphical Data” (page A-47)
	Clear Trigger Bit Address	Designate a trigger bit in order to clear the drawn image. When the clearing bit turns ON, a Clearing Screen will overwrite the displayed screen. <b>NOTE</b> • When the Clearing Screen appears, this will automatically turn OFF.
	Screen No. to Clear	Designate a screen number (base screen) in order to clear the drawn image. You have to have a previously prepared Clearing Screen.
	Call Position of Screen to Clear	Designate the Clearing Screen's call position (X coordinate, Y coordinate). <b>NOTE</b> • The top-left of the screen becomes coordinate (0, 0).
	Read After Startup	Read graphical data when the [Trigger Settings]' condition is satisfied. This improves the performance of processes other than reading. <b>NOTE</b> • This action cannot be used when the [Data Storage Word Address] is an internal device.

■ **Graphical Data**

Graphical data starting from the Data Storage Start Address will be as follows.

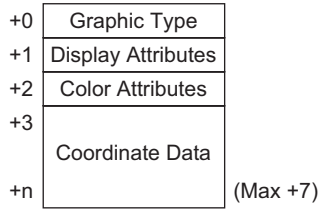

◆ **Graphic Type (+0)**

You can display a line, rectangle, circle, or dot. The following corresponding values will be stored.

Line: “1”, Rectangle: “2”, Circle: “3”, Dot: “5”

◆ **Display Attributes (+1)**

The display attributes, such as Line Type and Pattern, differ depending on each graphic. When drawing a dot, the display attributes (+1) data will be ignored.

- When drawing a line

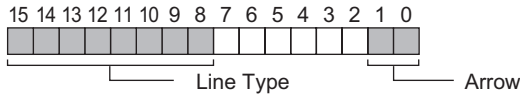

Arrow

Stored Value	Arrow
0	None
1	One Side
2	Both Ends

Line Type

Stored Value	Line Type
0	(Solid Line: 1-dot thickness)
1	(Dashed Line: 1-dot thickness)
2	(Chain Line: 1-dot thickness)
3	(Two-Dot Chain Line: 1-dot thickness)
4	(Solid Line: 2-dot thickness)
5	(Dashed Line: 2-dot thickness)
6	(Chain Line: 2-dot thickness)
7	(Two-Dot Chain Line: 2-dot thickness)
8	(Solid Line: 3-dot thickness)
9	(Solid Line: 5-dot thickness)

- When drawing a rectangle

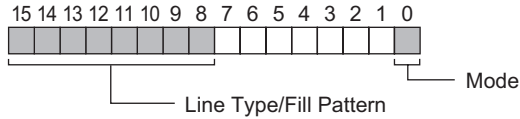

Mode

Stored Value	Mode
0	Draw Line
1	Fill

Line Type/Fill Pattern

Stored Value	Line Type	Fill Pattern
0	(Solid Line: 1-dot thickness)	
1	(Dashed Line: 1-dot thickness)	
2	(Chain Line: 1-dot thickness)	
3	(Two-Dot Chain Line: 1-dot thickness)	
4		
5		
6		
7		
8	(Solid Line: 3-dot thickness)	
9	(Solid Line: 5-dot thickness)	

- When drawing a circle

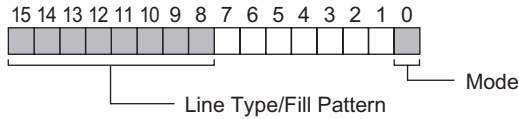

Mode

Stored Value	Mode
0	Draw Line
1	Fill

Line Type/Fill Pattern

Stored Value	Line Type	Fill Pattern
0	(Solid Line: 1-dot thickness)	
1	(Dashed Line: 1-dot thickness)	
2	(Chain Line: 1-dot thickness)	
3	(Two-Dot Chain Line: 1-dot thickness)	
4		
5		
6		
7		
8	(Solid Line: 3-dot thickness)	
9	(Solid Line: 5-dot thickness)	

◆ **Color Attributes (+2)**

You can set the display color, background color, and individual blink settings. As shown below, display color data is stored in bit 0 to 7, and background color data is stored in bit 8 to 15.

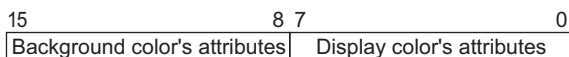

The format used to store attribute data differs depending on the following display colors and whether or not blink is set.

- 256-Color Display (No Blink)
  - 64-Color Display + 3-Speed Blink
  - Monochrome 16 Levels + 3-Speed Blink
- For 256-Color Display (No Blink)
    - As shown below, the display color's color code is stored in bit 0 to 7, and the background color's color code is stored in bit 8 to 15. For information about color codes, please refer to the following table.

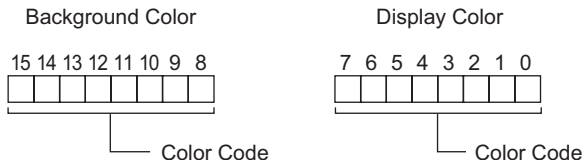

Color Code Table

Color Code	RGB Code	Color Code	RGB Code	Color Code	RGB Code	Color Code	RGB Code
0	00h	64	6Eh	128	CCh	192	A2h
1	01h	65	7Eh	129	DCh	193	B2h
2	02h	66	7Fh	130	DDh	194	B3h
3	03h	67	6Fh	131	CDh	195	A3h
4	04h	68	2Eh	132	C4h	196	AAh
5	05h	69	3Eh	133	D4h	197	BAh
6	06h	70	3Fh	134	D5h	198	BBh
7	07h	71	2Fh	135	C5h	199	ABh
8	10h	72	82h	136	8Ch	200	E2h
9	11h	73	92h	137	9Ch	201	F2h
10	20h	74	93h	138	9Dh	202	F3h
11	30h	75	83h	139	8Dh	203	E3h
12	31h	76	8Ah	140	84h	204	EAh
13	21h	77	9Ah	141	94h	205	FAh
14	22h	78	9Bh	142	95h	206	FBh
15	32h	79	8Bh	143	85h	207	EBh
16	33h	80	C2h	144	28h	208	EEh
17	23h	81	D2h	145	38h	209	FEh
18	12h	82	D3h	146	39h	210	FFh
19	13h	83	C3h	147	29h	211	EFh
20	40h	84	CAh	148	68h	212	E6h
21	50h	85	DAh	149	78h	213	F6h
22	51h	86	DBh	150	79h	214	F7h
23	41h	87	CBh	151	69h	215	E7h
24	60h	88	CEh	152	6Ch	216	AEh
25	70h	89	DEh	153	7Ch	217	BEh
26	71h	90	DFh	154	7Dh	218	BFh
27	61h	91	CFh	155	6Dh	219	AFh
28	62h	92	C6h	156	2Ch	220	A6h
29	72h	93	D6h	157	3Ch	221	B6h
30	73h	94	D7h	158	3Dh	222	B7h
31	63h	95	C7h	159	2Dh	223	A7h
32	42h	96	8Eh	160	A0h	224	2Ah
33	52h	97	9Eh	161	B0h	225	3Ah
34	53h	98	9Fh	162	B1h	226	3Bh
35	43h	99	8Fh	163	A1h	227	2Bh
36	44h	100	86h	164	A8h	228	6Ah
37	54h	101	96h	165	B8h	229	7Ah
38	55h	102	97h	166	B9h	230	7Bh
39	45h	103	87h	167	A9h	231	6Bh
40	64h	104	0Ah	168	E0h	232	08h
41	74h	105	1Ah	169	F0h	233	18h
42	75h	106	1Bh	170	F1h	234	19h
43	65h	107	0Bh	171	E1h	235	09h
44	66h	108	4Ah	172	E8h	236	48h
45	76h	109	5Ah	173	F8h	237	58h
46	77h	110	5Bh	174	F9h	238	59h
47	67h	111	4Bh	175	E9h	239	49h
48	46h	112	4Eh	176	ECh	240	4Ch
49	56h	113	5Eh	177	FCh	241	5Ch
50	57h	114	5Fh	178	FDh	242	5Dh
51	47h	115	4Fh	179	EDh	243	4Dh
52	14h	116	0Eh	180	E4h	244	0Ch
53	15h	117	1Eh	181	F4h	245	1Ch
54	24h	118	1Fh	182	F5h	246	1Dh
55	34h	119	0Fh	183	E5h	247	0Dh
56	35h	120	C0h	184	ACH	248	90h
57	25h	121	D0h	185	BCh	249	91h
58	26h	122	D1h	186	BDh	250	81h
59	36h	123	C1h	187	ADh	251	88h
60	37h	124	C8h	188	A4h	252	98h
61	27h	125	D8h	189	B4h	253	99h
62	16h	126	D9h	190	B5h	254	89h
63	17h	127	C9h	191	A5h	255	80h

- For 64-Color Display + 3-Speed Blink

As shown below, the display color's color code is stored in bit 0 to 5, and the background color's color code is stored in bit 8 to 13. For information about color codes, please refer to the 256-Color Display color code table.

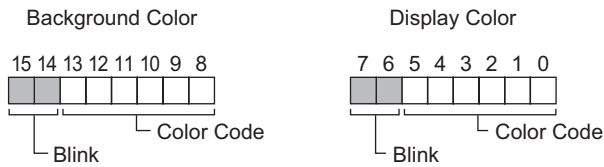

**Blink Storage Values**

Bit 7 Bit 15	Bit 6 Bit 14	Blink State
0	0	No Blink
0	1	High Speed Blink
1	0	Medium Speed Blink
1	1	Low Speed Blink

- For Monochrome 16 Levels + 3-Speed Blink

As shown below, the display color's color code is stored in bit 0 to 3, and the background color's color code is stored in bit 8 to 11. For information about color codes, please refer to the following table.

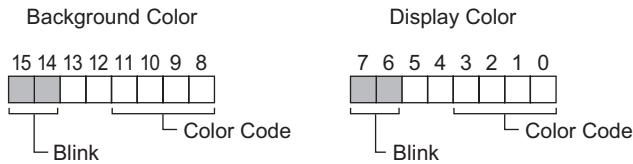

**Color Code Table**

Color Code	0	1	2	3	...	12	13	14	15	
Display Color	Black	→								White

**Blink Storage Values**

Bit 7 Bit 15	Bit 6 Bit 14	Blink State
0	0	No Blink
0	1	High Speed Blink
1	0	Medium Speed Blink
1	1	Low Speed Blink

◆ **Coordinate Data (+3)**

For coordinate data, the top-left of the screen is coordinate (0, 0). For graphics in a window, the top-left of the screen registered as a window is coordinate (0, 0).

- When drawing a line

+3	Start Point X Coordinate
+4	Start Point Y Coordinate
+5	End Point X Coordinate
+6	End Point Y Coordinate

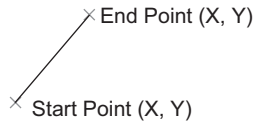

- When drawing a rectangle

+3	Start Point X Coordinate
+4	Start Point Y Coordinate
+5	End Point X Coordinate
+6	End Point Y Coordinate

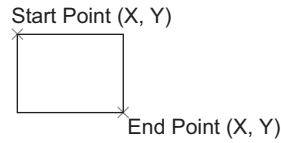

- When drawing a circle

+3	Center X Coordinate
+4	Center Y Coordinate
+5	Radius

Radius: 0 is invalid

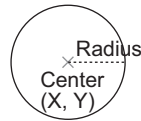

- When drawing a dot

+3	Center X Coordinate
+4	Center Y Coordinate



## A.2.2 Trigger Action Restrictions

- For the trigger bit's ON/OFF, make sure to leave an interval longer than the communication cycle time<sup>\*1</sup> or display scan time<sup>\*2</sup>, whichever is longer.
- After you turn ON the Trigger Bit Address, a screen change occurs before the drawing or erasing is complete, the Trigger Bit Address will be turned OFF.
- The graphical data to be stored can only be Bin data. You cannot use BCD data.
- If the graphical data to be stored is outside the range, it will become the default value, "0".
- For coordinate data, the top-left of the screen is coordinate (0, 0). For graphics in a window, the top-left of the screen registered as a window is coordinate (0, 0).
- For the color attribute's background color, if you designate "Black + Medium Speed Blink" or color code 255, the background color will become transparent.
- The following shows actions which occur immediately after a screen is changed or power is turned ON.

Trigger Condition	Direct Access Method		Memory Link Method	
	Bit Value "0"	Bit Value "1"	Bit Value "0"	Bit Value "1"
0 → 1 (Bit Rising)	×	○	×	×
1 → 0 (Bit Falling)	○	×	×	×
0 ↔ 1 (Bit Changing State)	○	○	×	×

○: Operation is performed immediately after the screen is changed, or the power is turned ON.

×: Operation is not performed immediately after the screen is changed, or the power is turned ON.

\*1 The communication cycle time is the time it takes to request and take in data from the GP unit to the PLC. It is stored in the internal device's LS2037 as binary data. The unit is milliseconds (ms). There is an error of ±10ms.

\*2 Display Scan Time is the time it takes to display/calculate 1 screen. It is stored in the internal device's LS2036 as binary data. The unit is milliseconds (ms). There is an error of ±10ms.

## A.3 Drawing Using Foreign Languages

### A.3.1 Details

This appendix describes how to draw a switch label using a foreign language. The descriptions use a simplified Chinese stroke font as an example.

In addition to simplified Chinese, GP-Pro EX supports drawing in Japanese, Taiwanese (traditional Chinese) and Korean.

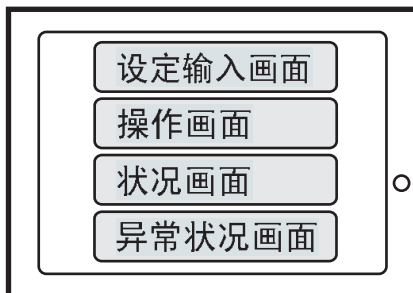

### A.3.2 Setting Procedure

- NOTE**
- This procedure shows how to use Chinese to enter the label of the screen-changing switch described in Section 12.2 , “Changing the Displayed Screen by Touch”. See that section for how to set screen-changing switches.
    - ☞ “12.2 Changing the Displayed Screen by Touch” (page 12-4)
  - For more information on stroke fonts, see Section 4.2 , “Stroke Font, Standard Font”.
    - ☞ “4.2 Stroke Font, Standard Font” (page 4-3)

Follow the steps below to draw a switch label in a foreign language (simplified Chinese in this example).

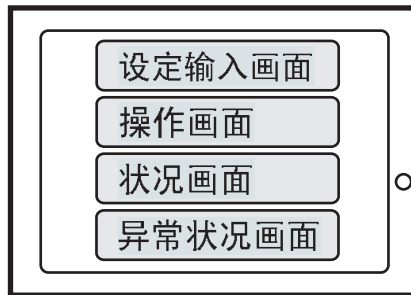

Make the three settings below. Click the page numbers in numerical order, follow the steps, then continue the procedure.

1. Add Chinese (simplified) to the Windows® multi-language display/input function settings.
  - “◆ When using Windows® XP” (page A-56)
  - “◆ When using Windows® 2000” (page A-58)
2. ■ Add Chinese Stroke Font to the Project. (page A-60)
3. ■ Inputting Into a Change Screen Switch’s Label with Chinese (Simplified) (page A-62)

#### ■ Adding Chinese (simplified) to the Windows® multi-language display/ input function settings.

##### ◆ When using Windows® XP

- 1 Open [Control Panel] from the [Start] menu, and double-click [Regional and Language Options].
- 2 Click the [Details] button under [Text services and input languages] in the [Languages] tab.

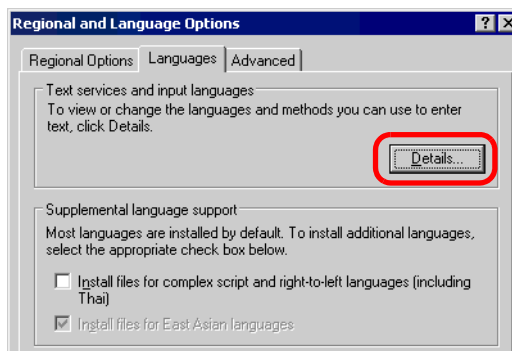

- 3 The [Text Services and Input Languages] dialog box appears. Click the [Add...] button under [Installed services] in the [Settings] tab.

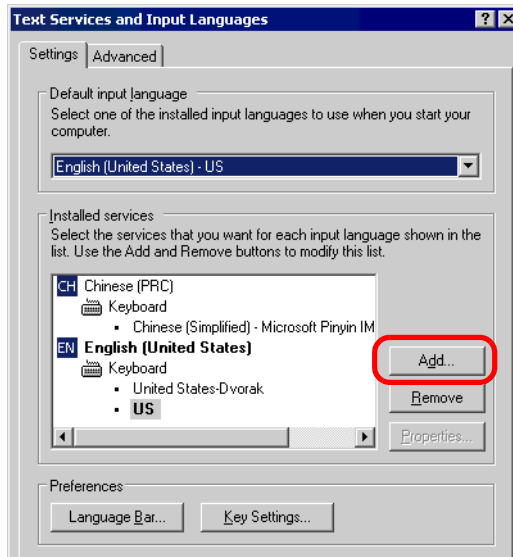

- 4 In the [Add Input language] dialog box, select the desired language in [Input language] ([Chinese (PRC)] in this example) and in [Keyboard layout/IME] ([Chinese (Simplified) - Microsoft Pinyin IME 3.0] in this example). Click [OK] to close the dialog box.

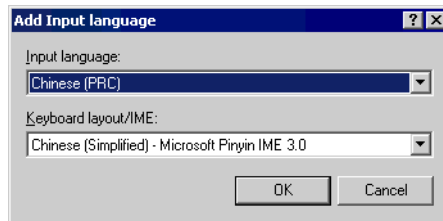

- 5 The [Text Services and Input Languages] dialog box returns. Check that [Chinese (Simplified) - Microsoft Pinyin IME 3.0] has been added to [Installed services], click [Apply], then [OK] to close the dialog box.

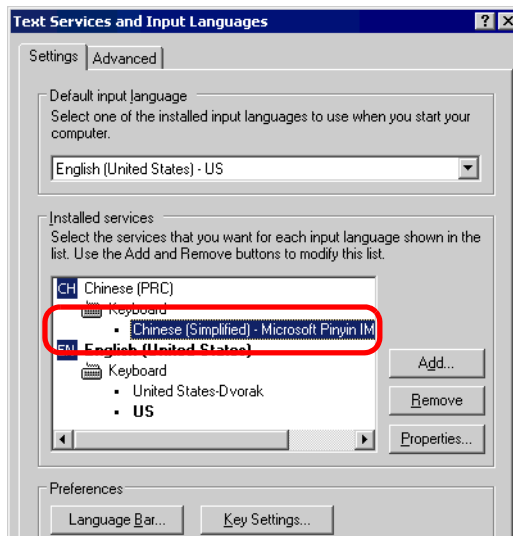

- 6 The [Regional and Language Options] dialog box returns. Click [OK] to close it.

◆ **When using Windows® 2000**

- 1 Open [Control Panel] from [Settings] in the [Start] menu, and double-click [Regional Options].
- 2 Select [Simplified Chinese] under [Language settings for the system] in the [General] tab, and click [OK].

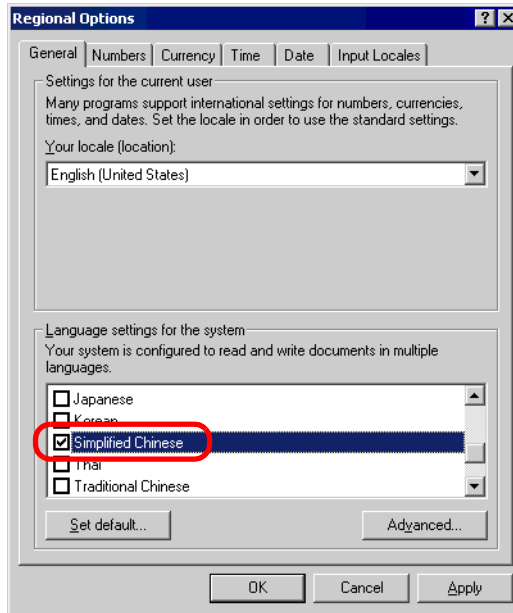

**NOTE** • The dialog box below appears when adding simplified Chinese for the first time. Insert the Windows® 2000 CD-ROM into the PC and click [OK].

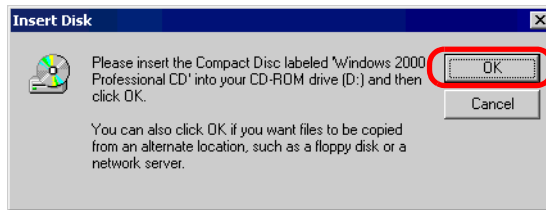

- 3 When the data has finished being copied from the CD-ROM, you must restart the PC. The dialog box below appears. Click [OK].

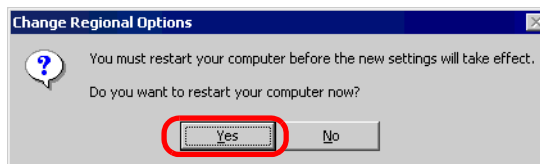

- 4 After restarting, open [Control Panel] from [Settings] in the [Start] menu, and double-click [Keyboard].

- Open the [Input Locales] tab on the [Keyboard Properties] dialog box, and click the [Add] button under [Installed input locales].

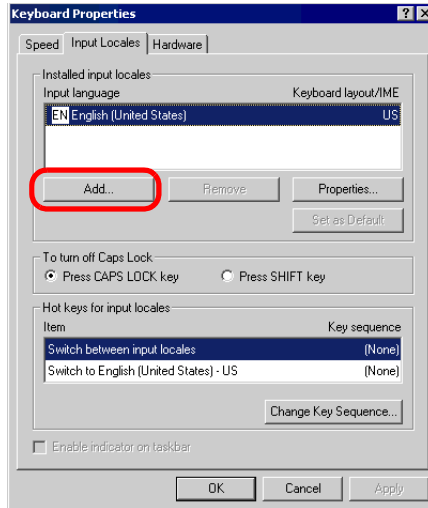

- The [Add Input Locale] dialog box appears. Select the language to add from the pull-down menu and click [OK].  
(e.g.) [Chinese (PRC)] is selected in [Input locale] and [Chinese (Simplified) - MS-PinYin98] is selected in [Keyboard layout/IME].

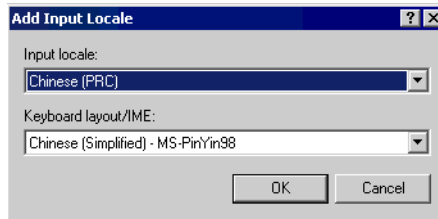

- Verify that [Chinese (PRC)] is added to the languages in [Installed input locales]. Click the [Apply] button and click [OK] to close the window.

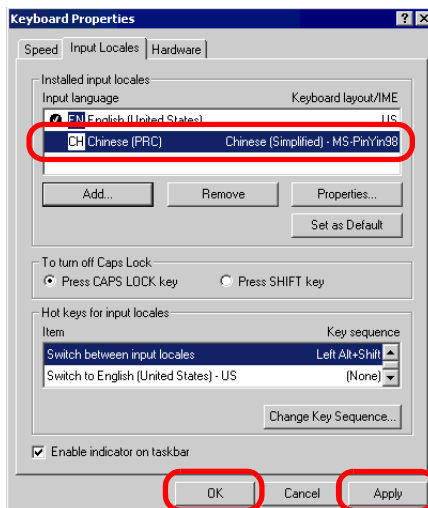

## ■ Add Chinese Stroke Font to the Project

**NOTE**

- Please refer to the following for details about Stroke Font.  
 “4.2 Stroke Font, Standard Font” (page 4-3)

1 Select GP-Pro EX’s [System Settings Window] menu - [Font Settings] command and then the [Font Settings] screen is displayed.

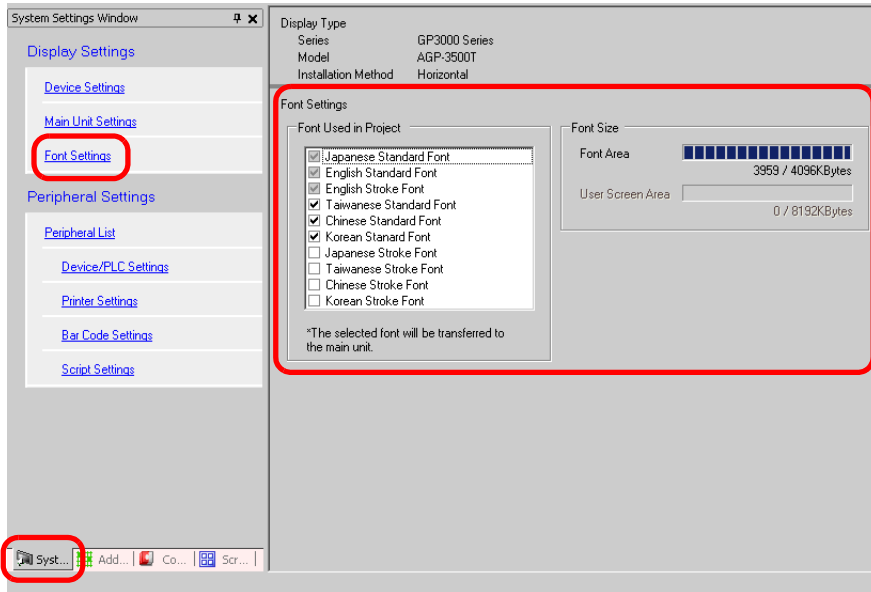

**NOTE**

- If the [System Settings Window] tab is not displayed in the Work Space, select the [View (V)] menu - [Work Space (W)] option - [System Settings Window (S)] command.

2 Put a check mark next to the [Chinese Stroke Font] box under the [Font Used in Project] to add the font.

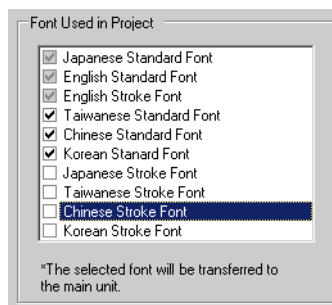

3 When you place a check mark, the following message is displayed.

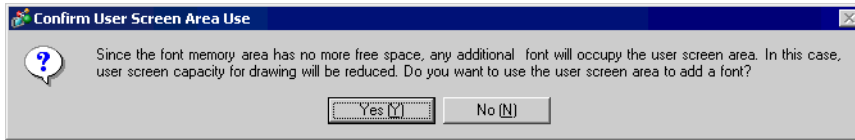

Click [Yes] to save the font data that the [Font Area] cannot store in the [User Screen Area] or to adjust the Font Area later as in the step 4. If you click [Yes], you can confirm that the User Screen Area is also used.

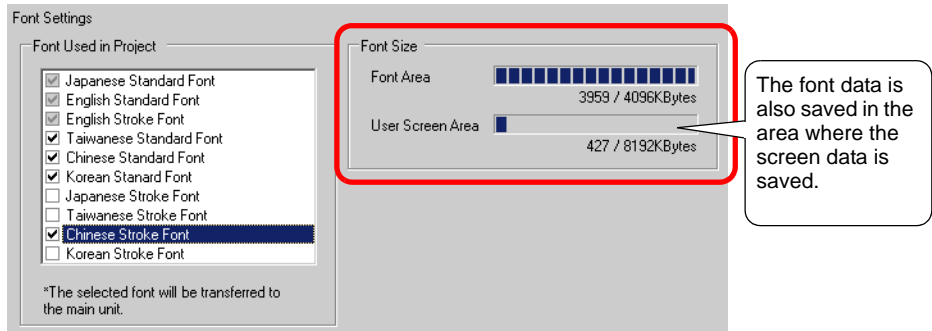

Click [No] to cancel adding the font.

4 Clear the check box for the fonts you are not using. This allows more free space in the Font Area.

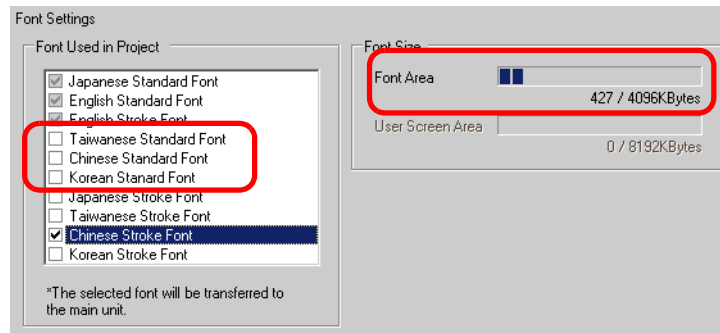

**NOTE**

- “Japanese Standard Font”, “English Standard Font”, and “English Stroke Font” are all fixed. You cannot remove these fonts.

## ■ Inputting Into a Change Screen Switch's Label with Chinese (Simplified)

- 1 Click the input system's icon ("Language" in Windows® XP) in the taskbar, and start "Chinese (PRC)".

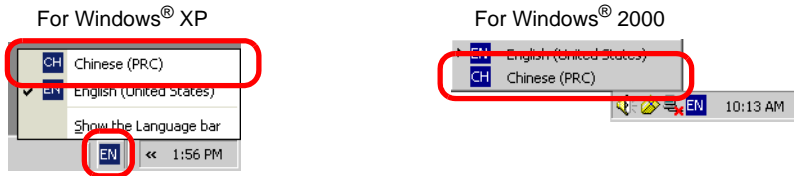

- 2 Start up GP-Pro EX, and double-click the Change Screen Switch created with the process in "12.2 Changing the Displayed Screen by Touch" (page 12-4) . Select the [Label] tab, set the [Font Type], [Display Language], and input with roman characters.

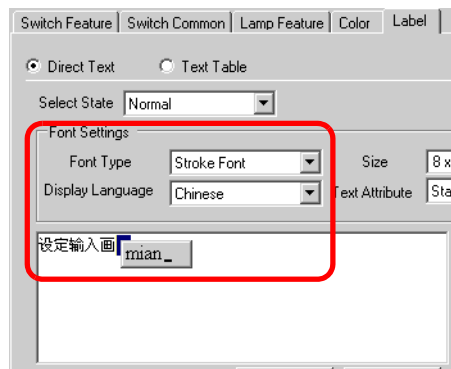

**NOTE**

- The moment you select the [Stroke Font] in [Font Type] or the moment you change the [Display Language], the following dialog box may be displayed. This is to confirm whether or not to add the font type, because a switch has been set before adding the font.

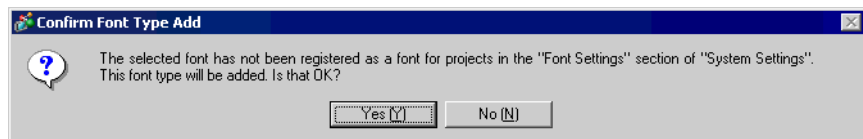

To add the font, click [Yes].

If you click [Cancel], adding the font is cancelled. If you transfer the text in this state to the GP, the set text cannot be displayed.

- 3 Click [OK] to close the [Switch/Lamp] dialog box. The Change Screen Switch's label changes to Chinese.

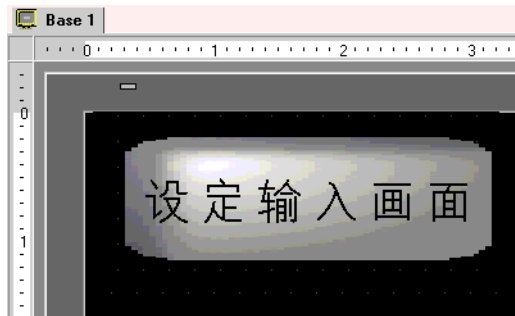

---

# *Memo*