



Controller (CPL) Driver

1	System Configuration.....	3
2	Selection of External Device	12
3	Example of Communication Setting.....	13
4	Setup Items.....	103
5	Cable Diagram	108
6	Supported Devices.....	256
7	Device Code and Address Code.....	281
8	Error Messages.....	287

Introduction

This manual describes how to connect the Display and the External Device (target controller).

In this manual, the connection procedure will be described by following the sections below:

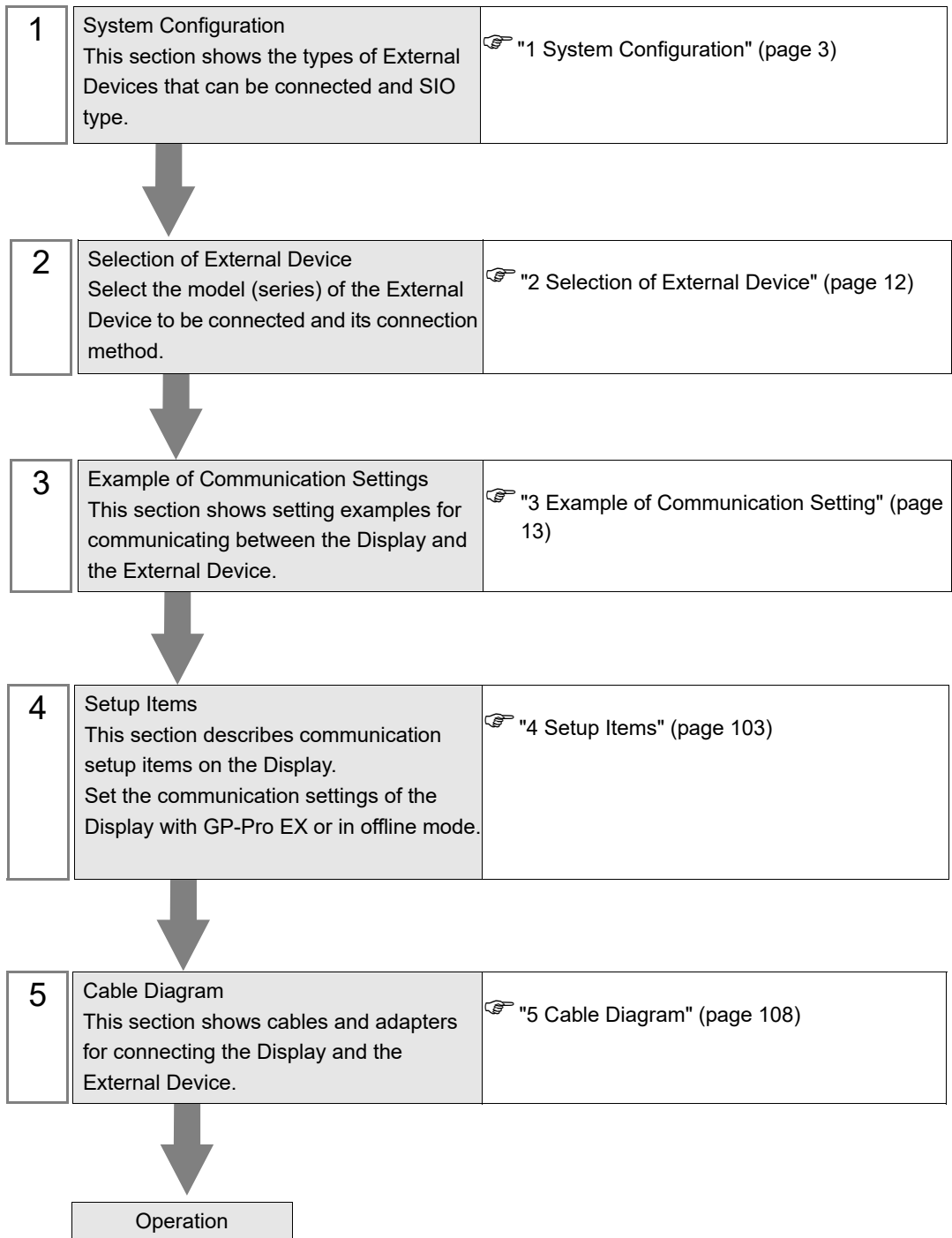

1 System Configuration

The following shows the system configuration where the External Device from Azbil Corporation and the Display are connected.

Series	Controller	Link I/F	SIO Type	Setting Example	Cable Diagram
SDC10	C10□□□□□05□□	Terminal block on the controller	RS422/485 (2wire)	Setting Example 1 (page 13)	Cable Diagram 5 (page 144)
SDC15	C15□□□□□03□□ C15□□□□□06□□	Terminal block on the controller	RS422/485 (2wire)	Setting Example 2 (page 15)	Cable Diagram 6 (page 157)
SDC20/21	C20□□□□□03□□ C20□□□□□05□□ C20□□□□□10□□ C21□□□□□04□□ C21□□□□□07□□ C21□□□□□09□□	Terminal block on the controller	RS232C	Setting Example 3 (page 17)	Cable Diagram 1 (page 108)
	C20□□□□□02□□ C20□□□□□04□□ C20□□□□□09□□ C21□□□□□03□□ C21□□□□□06□□ C21□□□□□08□□	Terminal block on the controller	RS422/485 (4wire) RS422/485 (2wire)	Setting Example 4 (page 19) Setting Example 5 (page 21)	Cable Diagram 2 (page 110) Cable Diagram 3 (page 118)
SDC25/26	C25□□□□□□2□□ C26□□□□□□2□□	Terminal block on the controller	RS422/485 (2wire)	Setting Example 6 (page 23)	Cable Diagram 6 (page 157)
SDC30/31	C30□□□□□040□□ C30□□□□□041□□ C31□□□□□045□□ C31□□□□□446□□ C31□□□□□546□□	Terminal block on the controller	RS422/485 (4wire)	Setting Example 7 (page 25)	Cable Diagram 2 (page 110)
			RS422/485 (2wire)	Setting Example 8 (page 27)	Cable Diagram 3 (page 118)
SDC35/36	C35□□□□□□2□□ C35□□□□□□4□□ C36□□□□□□2□□ C36□□□□□□4□□	Terminal block on the controller	RS422/485 (2wire)	Setting Example 9 (page 29)	Cable Diagram 6 (page 157)
SDC40A	C40A□□□□□□□3□□	Terminal block on the controller	RS232C	Setting Example 10 (page 31)	Cable Diagram 1 (page 108)
	C40A□□□□□□□2□□	Terminal block on the controller	RS422/485 (4wire)	Setting Example 11 (page 33)	Cable Diagram 2 (page 110)
			RS422/485 (2wire)	Setting Example 12 (page 35)	Cable Diagram 3 (page 118)

Series	Controller	Link I/F	SIO Type	Setting Example	Cable Diagram
SDC40B	C40B□□□□□□□□3□□	Terminal block on the controller	RS232C	Setting Example 13 (page 37)	Cable Diagram 1 (page 108)
	C40B□□□□□□□□2□□	Terminal block on the controller	RS422/485 (4wire)	Setting Example 14 (page 39)	Cable Diagram 2 (page 110)
			RS422/485 (2wire)	Setting Example 15 (page 41)	Cable Diagram 3 (page 118)
SDC40G	C40G□□□□□□095□□	Terminal block on the controller	RS422/485 (4wire)	Setting Example 16 (page 43)	Cable Diagram 2 (page 110)
			RS422/485 (2wire)	Setting Example 17 (page 45)	Cable Diagram 3 (page 118)
SDC45/46	C45A□□□□□□□□□□ C45A□□1 C46A□□□□□□□□□□ C46A□□1	Terminal block on the controller	RS422/485 (2wire)	Setting Example 29 (page 69)	Cable Diagram 8 (page 178)
DMC10	DMC10□□□□□□□□	Terminal block on the controller	RS422/485 (2wire)	Setting Example 18 (page 47)	Cable Diagram 4 (page 131)
DMC50	DMC50CH20□□□ DMC50CH40□□□ DMC50CS20□□□ DMC50CS40□□□	Terminal block on DMC50MR20□□	RS422/485 (4wire)	Setting Example 30 (page 71)	Cable Diagram 2 (page 110)
		Terminal block on DMC50ME20□□	RS422/485 (2wire)	Setting Example 31 (page 73)	Cable Diagram 3 (page 118)
DCP31	P31A□□□□□□□□2□□	Terminal block on the controller	RS422/485 (4wire)	Setting Example 19 (page 49)	Cable Diagram 2 (page 110)
			RS422/485 (2wire)	Setting Example 20 (page 51)	Cable Diagram 3 (page 118)
DCP32	P32A□□□□□□□□2□□	Terminal block on the controller	RS422/485 (4wire)	Setting Example 21 (page 53)	Cable Diagram 2 (page 110)
			RS422/485 (2wire)	Setting Example 22 (page 55)	Cable Diagram 3 (page 118)

Series	Controller	Link I/F	SIO Type	Setting Example	Cable Diagram
DCP551	DCP551□□□□2□□	Terminal block on the controller	RS232C	Setting Example 23 (page 57)	Cable Diagram 1 (page 108)
			RS422/485 (4wire)	Setting Example 24 (page 59)	Cable Diagram 2 (page 110)
			RS422/485 (2wire)	Setting Example 25 (page 61)	Cable Diagram 3 (page 118)
DCP552	DCP552□□□□2□□	Terminal block on the controller	RS232C	Setting Example 26 (page 63)	Cable Diagram 1 (page 108)
			RS422/485 (4wire)	Setting Example 27 (page 65)	Cable Diagram 2 (page 110)
			RS422/485 (2wire)	Setting Example 28 (page 67)	Cable Diagram 3 (page 118)
CMC10B	CMC10B	Communications connector on the host side	RS422/485 (4wire)	Setting Example 32 (page 75)	Cable Diagram 7 (page 170)
PBC	PBC-201VN2	Terminal block on the controller	RS422/485 (4wire)	Setting Example 33 (page 77)	Cable Diagram 2 (page 110)
			RS422/485 (2wire)	Setting Example 34 (page 79)	Cable Diagram 3 (page 118)
CMS	CMS9500□□□□□□1□□□□□ CMS0002□□□□□□1□□□□□ CMS0005□□□□□□1□□□□□ CMS0010□□□□□□1□□□□□ CMS0020□□□□□□1□□□□□ CMS0050□□□□□□1□□□□□ CMS0200□□□□□□1□□□□□ CMS0500□□□□□□1□□□□□ CMS1000□□□□□□1□□□□□ CMS1500□□□□□□1□□□□□ CMS2000□□□□□□1□□□□□	Terminal block on the controller	RS422/485 (2wire)	Setting Example 35 (page 81)	Cable Diagram 8 (page 178)
CMF	CMF015□	Terminal block on the controller	RS422/485 (2wire)	Setting Example 35 (page 81)	Cable Diagram 8 (page 178)
	CMF050	Terminal block on the controller	RS422/485 (4wire)	Setting Example 36 (page 83)	Cable Diagram 9 (page 191)
			RS422/485 (2wire)	Setting Example 37 (page 85)	Cable Diagram 10 (page 207)

Series	Controller	Link I/F	SIO Type	Setting Example	Cable Diagram
CMQ-V	MQV9005□□□□□□1□□□□ MQV9020□□□□□□1□□□□ MQV9200□□□□□□1□□□□ MQV9500□□□□□□1□□□□ MQV0002□□□□□□1□□□□ MQV0005□□□□□□1□□□□ MQV0020□□□□□□1□□□□ MQV0050□□□□□□1□□□□ MQV0200□□□□□□1□□□□ MQV0500□□□□□□1□□□□	Terminal block	RS422/485 (2wire)	Setting Example 38 (page 87)	Cable Diagram 11 (page 231)
MPC	MPC9500□□□□□□2□□□□ MPC0002□□□□□□2□□□□ MPC0005□□□□□□2□□□□ MPC0020□□□□□□2□□□□	Terminal block on the controller	RS422/485 (2wire)	Setting Example 39 (page 89)	Cable Diagram 8 (page 178)
MVF	MVF050□□□□□□□1□□□□ MVF080□□□□□□□1□□□□ MVF100□□□□□□□1□□□□ MVF150□□□□□□□1□□□□	Terminal block on the controller	RS422/485 (2wire)	Setting Example 40 (page 91)	Cable Diagram 8 (page 178)
CML	CML050□□□□□□□1□□□□ CML080□□□□□□□1□□□□ CML100□□□□□□□1□□□□ CML150□□□□□□□1□□□□	Terminal block	RS422/485 (4wire)	Setting Example 36 (page 83)	Cable Diagram 9 (page 191)
			RS422/485 (2wire)	Setting Example 37 (page 85)	Cable Diagram 10 (page 207)
AUR350C	AUR350C□□□□□□	Terminal block on the controller	RS422/485 (2wire)	Setting Example 41 (page 93)	Cable Diagram 4 (page 131)
AUR450C	AUR450C□□□□□□□□	Terminal block on the controller	RS422/485 (2wire)	Setting Example 42 (page 95)	Cable Diagram 4 (page 131)
RX	RX-L80□□□□□□□□	Terminal block on the controller	RS422/485 (2wire)	Setting Example 43 (page 97)	Cable Diagram 8 (page 178)
BC-R	BC-R25□□□□□□□□ BC-R35□□□□□□□□	Front Connector on the controller	RS422/485 (2wire)	Setting Example 44 (page 99)	Cable Diagram 8 (page 178)
C1M	C1MT□□□□03□□ C1MT□□□□06□□ C1MT□□□□09□□	Terminal block on the CPU	RS422/485 (2wire)	Setting Example 45 (page 101)	Cable Diagram 12 (page 255)

◆ Connection Configuration

- 1:1 Connection

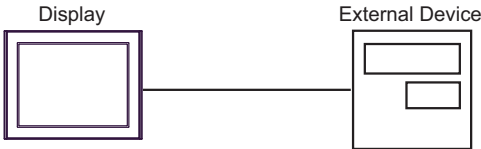

- 1:n Connection
using 1 port

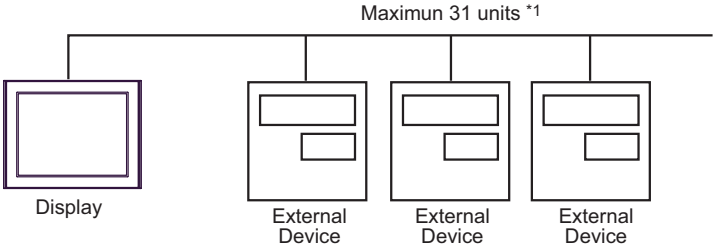

using 2 port or more

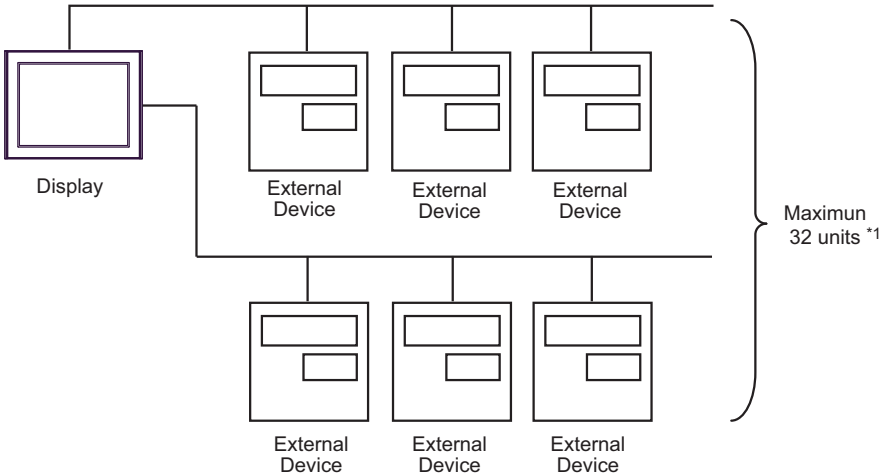

- 1:n Connection (when CMC10B is used)

Up to 16 units of CMC10B can be connected to one Display.

In addition, up to 31 External Devices that support CPL communication can be connected to CMC10B. CMC10B always collects set data, allowing improved communication performance when many devices are connected.

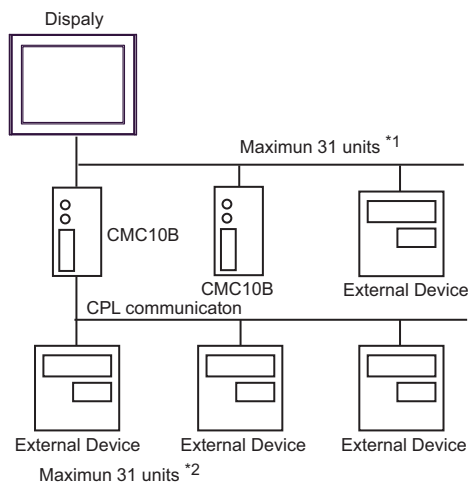

*1 Up to 15 units can be connected if the External Devices include DMC10 or DMC50.

*2 Up to 15 units can be connected if the External Devices include DMC10. Note that DMC50 cannot be used.

NOTE

- For 1:n connection, do not add termination resistors if the Controllers to be connected include any of the following series.

- SDC15
- SDC25/26
- SDC35/36
- DMC10

■ IPC COM Port

When connecting IPC with an External Device, the COM port used depends on the series and SIO type. Please refer to the IPC manual for details.

Usable port

Series	Usable Port		
	RS-232C	RS-422/485(4 wire)	RS-422/485(2 wire)
PS-2000B	COM1 ^{*1} , COM2, COM3 ^{*1} , COM4	-	-
PS-3450A, PS-3451A, PS3000-BA, PS3001-BD	COM1, COM2 ^{*1*2}	COM2 ^{*1*2}	COM2 ^{*1*2}
PS-3650A (T41 model), PS-3651A (T41 model)	COM1 ^{*1}	-	-
PS-3650A (T42 model), PS-3651A (T42 model)	COM1 ^{*1*2} , COM2	COM1 ^{*1*2}	COM1 ^{*1*2}
PS-3700A (Pentium®4-M) PS-3710A	COM1 ^{*1} , COM2 ^{*1} , COM3 ^{*2} , COM4	COM3 ^{*2}	COM3 ^{*2}
PS-3711A	COM1 ^{*1} , COM2 ^{*2}	COM2 ^{*2}	COM2 ^{*2}
PS4000 ^{*3}	COM1, COM2	-	-
PL3000	COM1 ^{*1*2} , COM2 ^{*1} , COM3, COM4	COM1 ^{*1*2}	COM1 ^{*1*2}
PE-4000B Atom N270	COM1, COM2	-	-
PE-4000B Atom N2600	COM1, COM2	COM3 ^{*4} , COM4 ^{*4} , COM5 ^{*4} , COM6 ^{*4}	COM3 ^{*4} , COM4 ^{*4} , COM5 ^{*4} , COM6 ^{*4}
PS5000 (Slim Panel Type Core i3 Model) ^{*5*6}	COM1, COM2 ^{*4}	COM2 ^{*4}	COM2 ^{*4}
PS5000 (Slim Panel Type Atom Model) ^{*5*6}	COM1, COM2 ^{*7}	COM2 ^{*7}	COM2 ^{*7}
PS5000 (Enclosed Panel Type) ^{*8}	COM1	-	-
PS5000 (Modular Type PFXPU/PFXPP) ^{*5*6} PS5000 (Modular Type PFXPL2B5-6)	COM1 ^{*7}	COM1 ^{*7}	COM1 ^{*7}
PS5000 (Modular Type PFXPL2B1-4)	COM1, COM2 ^{*7}	COM2 ^{*7}	COM2 ^{*7}
PS6000 (Advanced Box) PS6000 (Standard Box)	COM1 ^{*9}	*10	*10
PS6000 (Basic Box)	COM1 ^{*9}	COM1 ^{*9}	COM1 ^{*9}

*1 The RI/5V can be switched. Use the IPC's switch to change if necessary.

*2 Set up the SIO type with the DIP Switch. Please set up as follows according to SIO type to be used.

- *3 When making communication between an External Device and COM port on the Expansion slot, only RS-232C is supported. However, ER (DTR/CTS) control cannot be executed because of the specification of COM port.
For connection with External Device, use user-created cables and disable Pin Nos. 1, 4, 6 and 9. Please refer to the IPC manual for details of pin layout.
- *4 Set up the SIO type with the BIOS. Please refer to the IPC manual for details of BIOS.
- *5 When setting up communication between an External Device and the RS-232C/422/485 interface module, use the IPC (RS-232C) or PS5000 (RS-422/485) cable diagrams. However, when using PFXZPBMPR42P2 in a RS-422/485 (4-wire) configuration with no flow control, connect 7.RTS+ and 8.CTS+, and connect 6.RTS- and 9.CTS-.
When using RS-422/485 communication with External Devices, you may need to reduce the transmission speed and increase the TX Wait time.
- *6 To use RS-422/485 communication on the RS-232C/422/485 interface module, the DIP Switch setting is required. Please refer to "Knowledge Base" (FAQs) on the support site. (<http://www.pro-face.com/trans/en/manual/1001.html>)

Settings	FAQ ID
PFXZPBMPR42P2, RS422/485 change method	FA263858
PFXZPBMPR42P2 termination resistor setting	FA263974
PFXZPBMPR44P2, RS422/485 change method	FA264087
PFXZPBMPR44P2 termination resistor setting	FA264088

- *7 Set up the SIO type with the DIP Switch. Please refer to the IPC manual for details of DIP Switch. The BOX Atom has not a switch to set the RS-232C, RS-422/485 mode. Use the BIOS for the setting.
- *8 For the connection with the External Device, on the user-created cable read as if the connector on the Display-side is a M12 A-coding 8 pin socket. The pin assignment is the same as described in the cable diagram. For the M12 A-coding connector, use PFXZPSCNM122.
- *9 In addition to COM1, you can also use the COM port on the optional interface.
- *10 Install the optional interface in the expansion slot.

DIP Switch settings (PL3000 / PS3000 Series)

RS-232C

DIP Switch	Setting	Description
1	OFF*1	Reserved (always OFF)
2	OFF	SIO type: RS-232C
3	OFF	
4	OFF	Output mode of SD (TXD) data: Always output
5	OFF	Terminal resistance (220Ω) insertion to SD (TXD): None
6	OFF	Terminal resistance (220Ω) insertion to RD (RXD): None
7	OFF	Short-circuit of SDA (TXA) and RDA (RXA): Not available
8	OFF	Short-circuit of SDB (TXB) and RDB (RXB): Not available
9	OFF	RS (RTS) Auto control mode: Disabled
10	OFF	

*1 When using PS-3450A, PS-3451A, PS3000-BA and PS3001-BD, turn ON the set value.

RS-422/485 (4 wire)

DIP Switch	Setting	Description
1	OFF	Reserved (always OFF)
2	ON	SIO type: RS-422/485
3	ON	
4	OFF	Output mode of SD (TXD) data: Always output
5	OFF	Terminal resistance (220Ω) insertion to SD (TXD): None
6	OFF	Terminal resistance (220Ω) insertion to RD (RXD): None
7	OFF	Short-circuit of SDA (TXA) and RDA (RXA): Not available
8	OFF	Short-circuit of SDB (TXB) and RDB (RXB): Not available
9	OFF	RS (RTS) Auto control mode: Disabled
10	OFF	

RS-422/485 (2 wire)

DIP Switch	Setting	Description
1	OFF	Reserved (always OFF)
2	ON	SIO type: RS-422/485
3	ON	
4	OFF	Output mode of SD (TXD) data: Always output
5	OFF	Terminal resistance (220Ω) insertion to SD (TXD): None
6	OFF	Terminal resistance (220Ω) insertion to RD (RXD): None
7	ON	Short-circuit of SDA (TXA) and RDA (RXA): Available
8	ON	Short-circuit of SDB (TXB) and RDB (RXB): Available
9	ON	RS (RTS) Auto control mode: Enabled
10	ON	

2 Selection of External Device

Select the External Device to be connected to the Display.

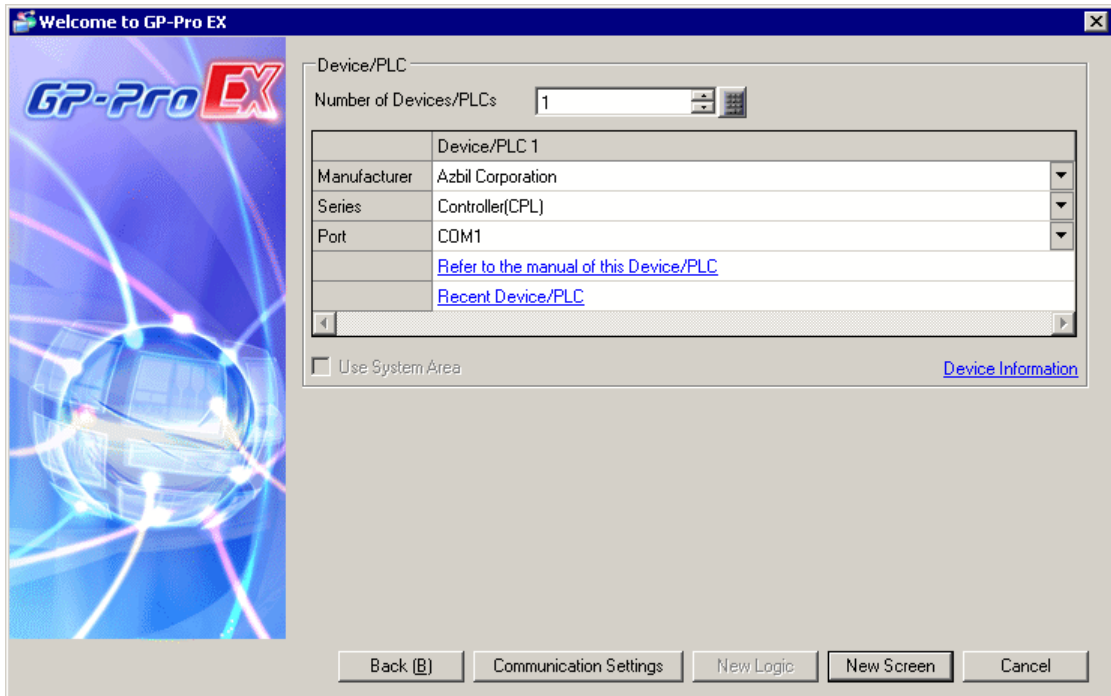

Setup Items	Setup Description
Number of Devices/PLCs	Enter an integer from 1 to 4 to define the number of Devices/PLCs to connect to the display.
Manufacturer	Select the manufacturer of the External Device to connect. Select "Azbil Corporation".
Series	Select the External Device model (series) and the connection method. Select "Controller(CPL)". In System configuration, make sure the External Device you are connecting is supported by "Controller(CPL)". ☞ "1 System Configuration" (page 3)
Port	Select the Display port to be connected to the External Device.
Use System Area	Not available in this driver.

3 Example of Communication Setting

The following shows examples of communication settings for the Display and the External Device, which are recommended by Pro-face.

3.1 Setting Example 1

■ Setting of GP-Pro EX

◆ Communication Settings

To display the setup screen, from the [Project] menu, point to [System Settings] and select [Device/PLC].

Device/PLC 1

Summary [Change Device/PLC](#)

Manufacturer Series Port

Text Data Mode [Change](#)

Communication Settings

RS232C
 RS422/485(2wire)
 RS422/485(4wire)

Speed

Data Length 7 8

Parity NONE EVEN ODD

Stop Bit 1 2

Flow Control NONE ER(DTR/CTS) XON/XOFF

Timeout (sec)

Retry

Wait To Send (ms)

RI VCC

In the case of RS232C, you can select the 9th pin to RI (Input) or VCC (5V Power Supply). If you use the Digital's RS232C Isolation Unit, please select it to VCC.

Device-Specific Settings

Allowable Number of Devices/PLCs: 31 [Add Device](#)

No.	Device Name	Settings	Add Indirect Device
1	PLC1	Series=SDC10,Device Address=1,Sub Address=0	<input type="button" value="Add Indirect Device"/>

IMPORTANT

- To use SDC10, you need to set Wait To Send to 70ms or more.

◆ Device Setting

To display the [Individual Device Settings] dialog box, from [Device-Specific Settings] in the [Device/PLC] window, select the external device and click [Settings] .

To connect multiple External Devices, from [Device-Specific Settings] in the [Device/PLC] window, click [Add Device] to add another External Device.



■ Settings of External Device

To configure communication settings for the External Device, use the PARA, ENT, Down and Up keys on the front of the Controller. Refer to your Controller manual for details.

◆ Procedure

- 1 In operation mode, press and hold the PARA key (for 3 seconds) to move to parameter mode.
- 2 In parameter mode, press and hold the PARA key (for 3 seconds) to move to setup mode.
- 3 Press the PARA key several times to display the desired setup item.
- 4 Use the Down/Up keys to select a setting. (The set value will blink.)
- 5 When no operation is performed for 2 seconds, the set value stops blinking and the change is fixed.
- 6 Press and hold the PARA key (for 3 seconds) to move to the basic display.

◆ Settings

Setup Items	Settings
C22	1
C23	0

NOTE

- The parameters to be set vary depending on the Controller. Refer to your Controller manual for details.

3.2 Setting Example 2

■ Setting of GP-Pro EX

◆ Communication Settings

To display the setup screen, from the [Project] menu, point to [System Settings] and select [Device/PLC].

Device/PLC 1

Summary [Change Device/PLC](#)

Manufacturer Series Port

Text Data Mode [Change](#)

Communication Settings

SID Type RS232C RS422/485(2wire) RS422/485(4wire)

Speed

Data Length 7 8

Parity NONE EVEN ODD

Stop Bit 1 2

Flow Control NONE ER(DTR/CTS) XON/XOFF

Timeout (sec)

Retry

Wait To Send (ms)

RI / VCC RI VCC

In the case of RS232C, you can select the 9th pin to RI (Input) or VCC (5V Power Supply). If you use the Digital's RS232C Isolation Unit, please select it to VCC.

[Default](#)

Device-Specific Settings

Allowable Number of Devices/PLCs 31 [Add Device](#)

No.	Device Name	Settings
1	PLC1	Series=SDC15,Device Address=1,Sub Address=0

[Add Indirect Device](#)

◆ Device Setting

To display the [Individual Device Settings] dialog box, from [Device-Specific Settings] in the [Device/PLC] window, select the external device and click [Settings] .

To connect multiple External Devices, from [Device-Specific Settings] in the [Device/PLC] window, click [Add Device] to add another External Device.

Individual Device Settings

PLC1

Series

Please reconfirm all of address settings that you are using if you have changed the series.

Device Address

Sub Address

[Default](#)

[OK \(O\)](#) [Cancel](#)

■ Settings of External Device

To configure communication settings for the External Device, use the PARA, mode, Down and Up keys on the front of the Controller. Refer to your Controller manual for details.

◆ Procedure

- 1 In the operation display, press and hold the PARA key (for 2 seconds) to move to the parameter setting display.
- 2 In the parameter setting display, press and hold the PARA key (for 2 seconds) to move to the setup display.
- 3 Press the PARA key several times to display the desired setup item.
- 4 Use the Down/Up keys to select a setting. (The set value will blink.)
- 5 When no operation is performed for 2 seconds, the set value stops blinking and the change is fixed.
- 6 Press the mode key to move to the basic display.

◆ Settings

Setup Items	Settings
C64	0
C65	1
C66	1
C67	1
C68	0
C69	0

NOTE

- The parameters to be set vary depending on the Controller. Refer to your Controller manual for details.

3.3 Setting Example 3

■ Setting of GP-Pro EX

◆ Communication Settings

To display the setup screen, from the [Project] menu, point to [System Settings] and select [Device/PLC].

The screenshot shows the 'Device/PLC 1' configuration window. It is divided into several sections:

- Summary:** Manufacturer: Azbil Corporation, Series: Controller(CPL), Port: COM1. Text Data Mode: 1. A 'Change Device/PLC' link is visible.
- Communication Settings:**
 - SI0 Type: RS232C, RS422/485(2wire), RS422/485(4wire)
 - Speed: 9600
 - Data Length: 7, 8
 - Parity: NONE, EVEN, ODD
 - Stop Bit: 1, 2
 - Flow Control: NONE, ER(DTR/CTS), XON/XOFF
 - Timeout: 3 (sec)
 - Retry: 2
 - Wait To Send: 10 (ms)
- RI / VCC:** RI, VCC. A note states: 'In the case of RS232C, you can select the 9th pin to RI (Input) or VCC (5V Power Supply). If you use the Digital's RS232C Isolation Unit, please select it to VCC.' A 'Default' button is present.
- Device-Specific Settings:** Allowable Number of Devices/PLCs: 31. An 'Add Device' link is present.
- Device List:** A table with columns 'No.', 'Device Name', and 'Settings'. It contains one entry: No. 1, Device Name PLC1, Settings Series=SDC20/21, Device Address=1, Sub Address=0. An 'Add Indirect Device' button is on the right.

◆ Device Setting

To display the [Individual Device Settings] dialog box, from [Device-Specific Settings] in the [Device/PLC] window, select the external device and click [Settings] .

To connect multiple External Devices, from [Device-Specific Settings] in the [Device/PLC] window, click [Add Device] to add another External Device.

The 'Individual Device Settings' dialog box is shown for device PLC1. It contains the following fields and controls:

- Series: SDC20/21 (dropdown menu)
- Text: Please reconfirm all of address settings that you are using if you have changed the series.
- Device Address: 1 (spin box)
- Sub Address: 0 (spin box)
- Buttons: Default, OK (O), Cancel

■ Settings of External Device

To configure communication settings for the External Device, use the ENT, DISP, Down and Up keys on the front of the Controller. Refer to your Controller manual for details.

◆ Procedure

- 1 In the basic display, press and hold the ENT and Down keys simultaneously (for 3 seconds or more) to display the setup items.
- 2 Press the Down/Up keys to select a setup item and press the ENT key.
- 3 Use the Down/Up keys to select a setting and press the ENT key.
- 4 Press the DISP key to move to the basic display.

◆ Settings

Setup Items	Settings
C31	1
C32	0
C33	0

NOTE

- The parameters to be set vary depending on the Controller. Refer to your Controller manual for details.

3.4 Setting Example 4

■ Setting of GP-Pro EX

◆ Communication Settings

To display the setup screen, from the [Project] menu, point to [System Settings] and select [Device/PLC].

The screenshot shows the 'Device/PLC 1' configuration window. It is divided into several sections:

- Summary:** Manufacturer: Azbil Corporation, Series: Controller(CPL), Port: COM1. Text Data Mode: 1.
- Communication Settings:**
 - SI0 Type: RS232C, RS422/485(2wire), RS422/485(4wire)
 - Speed: 9600
 - Data Length: 7, 8
 - Parity: NONE, EVEN, ODD
 - Stop Bit: 1, 2
 - Flow Control: NONE, ER(DTR/CTS), XON/XOFF
 - Timeout: 3 (sec)
 - Retry: 2
 - Wait To Send: 10 (ms)
- RI / VCC:** RI, VCC. A note states: "In the case of RS232C, you can select the 9th pin to RI (Input) or VCC (5V Power Supply). If you use the Digital's RS232C Isolation Unit, please select it to VCC." A 'Default' button is present.
- Device-Specific Settings:** Allowable Number of Devices/PLCs: 31. A table lists the device:

No.	Device Name	Settings
1	PLC1	Series=SDC20/21, Device Address=1, Sub Address=0

◆ Device Setting

To display the [Individual Device Settings] dialog box, from [Device-Specific Settings] in the [Device/PLC] window, select the external device and click [Settings] .

To connect multiple External Devices, from [Device-Specific Settings] in the [Device/PLC] window, click [Add Device] to add another External Device.

The 'Individual Device Settings' dialog box is shown for device PLC1. It contains the following fields and controls:

- Series: SDC20/21
- Device Address: 1
- Sub Address: 0
- Buttons: Default, OK (O), Cancel

A note in the dialog reads: "Please reconfirm all of address settings that you are using if you have changed the series."

■ Settings of External Device

To configure communication settings for the External Device, use the ENT, DISP, Down and Up keys on the front of the Controller. Refer to your Controller manual for details.

◆ Procedure

- 1 In the basic display, press and hold the ENT and Down keys simultaneously (for 3 seconds or more) to display the setup items.
- 2 Press the Down/Up keys to select a setup item and press the ENT key.
- 3 Use the Down/Up keys to select a setting and press the ENT key.
- 4 Press the DISP key to move to the basic display.

◆ Settings

Setup Items	Settings
C31	1
C32	0
C33	0

NOTE

- The parameters to be set vary depending on the Controller. Refer to your Controller manual for details.

3.5 Setting Example 5

■ Setting of GP-Pro EX

◆ Communication Settings

To display the setup screen, from the [Project] menu, point to [System Settings] and select [Device/PLC].

The screenshot shows the 'Device/PLC 1' configuration window. It is divided into several sections:

- Summary:** Manufacturer: Azbil Corporation, Series: Controller(CPL), Port: COM1. Text Data Mode: 1. A 'Change Device/PLC' link is visible.
- Communication Settings:**
 - SI0 Type: RS232C, RS422/485(2wire), RS422/485(4wire)
 - Speed: 9600
 - Data Length: 7, 8
 - Parity: NONE, EVEN, ODD
 - Stop Bit: 1, 2
 - Flow Control: NONE, ER(DTR/CTS), XON/XOFF
 - Timeout: 3 (sec)
 - Retry: 2
 - Wait To Send: 10 (ms)
- RI / VCC:** RI, VCC. A note states: 'In the case of RS232C, you can select the 9th pin to RI (Input) or VCC (5V Power Supply). If you use the Digital's RS232C Isolation Unit, please select it to VCC.' A 'Default' button is present.
- Device-Specific Settings:** Allowable Number of Devices/PLCs: 31. An 'Add Device' link is shown.
- Device List:** A table with columns 'No.', 'Device Name', and 'Settings'. It contains one entry: No. 1, Device Name PLC1, Settings Series=SDC20/21, Device Address=1, Sub Address=0. An 'Add Indirect Device' button is on the right.

◆ Device Setting

To display the [Individual Device Settings] dialog box, from [Device-Specific Settings] in the [Device/PLC] window, select the external device and click [Settings] .

To connect multiple External Devices, from [Device-Specific Settings] in the [Device/PLC] window, click [Add Device] to add another External Device.

The 'Individual Device Settings' dialog box for PLC1 is shown. It contains the following fields and controls:

- Series: SDC20/21
- Text: Please reconfirm all of address settings that you are using if you have changed the series.
- Device Address: 1
- Sub Address: 0
- Buttons: Default, OK (O), Cancel

■ Settings of External Device

To configure communication settings for the External Device, use the ENT, DISP, Down and Up keys on the front of the Controller. Refer to your Controller manual for details.

◆ Procedure

- 1 In the basic display, press and hold the ENT and Down keys simultaneously (for 3 seconds or more) to display the setup items.
- 2 Press the Down/Up keys to select a setup item and press the ENT key.
- 3 Use the Down/Up keys to select a setting and press the ENT key.
- 4 Press the DISP key to move to the basic display.

◆ Settings

Setup Items	Settings
C31	1
C32	0
C33	0

NOTE

- The parameters to be set vary depending on the Controller. Refer to your Controller manual for details.

3.6 Setting Example 6

■ Setting of GP-Pro EX

◆ Communication Settings

To display the setup screen, from the [Project] menu, point to [System Settings] and select [Device/PLC].

The screenshot shows the 'Device/PLC 1' configuration window. It is divided into several sections:

- Summary:** Manufacturer: Azbil Corporation, Series: Controller(CPL), Port: COM1. Text Data Mode: 1.
- Communication Settings:**
 - SI0 Type: RS232C, RS422/485(2wire), RS422/485(4wire)
 - Speed: 9600
 - Data Length: 7, 8
 - Parity: NONE, EVEN, ODD
 - Stop Bit: 1, 2
 - Flow Control: NONE, ER(DTR/CTS), XON/XOFF
 - Timeout: 3 (sec)
 - Retry: 2
 - Wait To Send: 10 (ms)
- RI / VCC:** RI, VCC. A note states: "In the case of RS232C, you can select the 9th pin to RI (Input) or VCC (5V Power Supply). If you use the Digital's RS232C Isolation Unit, please select it to VCC."
- Device-Specific Settings:** Allowable Number of Devices/PLCs: 31. A table lists one device:

No.	Device Name	Settings
1	PLC1	Series=SDC25/26, Device Address=1, Sub Address=0

◆ Device Setting

To display the [Individual Device Settings] dialog box, from [Device-Specific Settings] in the [Device/PLC] window, select the external device and click [Settings] .

To connect multiple External Devices, from [Device-Specific Settings] in the [Device/PLC] window, click [Add Device] to add another External Device.

The 'Individual Device Settings' dialog box for 'PLC1' is shown. It contains the following fields and controls:

- Series: SDC25/26
- Device Address: 1
- Sub Address: 0
- Buttons: Default, OK (O), Cancel

■ Settings of External Device

To configure communication settings for the External Device, use the para, mode, enter, Down and Up keys on the front of the Controller. Refer to your Controller manual for details.

◆ Procedure

- 1 In the operation display, press and hold the para key (for 2 seconds) to move to the bank selection display.
- 2 In the bank selection display, press the enter key to move to the bank setup display.
- 3 Press the para key several times to display the desired setup item.
- 4 Press the enter key to blink the set value displayed.
- 5 Use the Down/Up keys to select a setting.
- 6 Press the enter key to fix the change.
- 7 Press the mode key to move to the operation display.

◆ Settings

Setup Items	Settings
C64	0
C65	1
C66	1
C67	1
C68	0
C69	0

NOTE

- The parameters to be set vary depending on the Controller. Refer to your Controller manual for details.

3.7 Setting Example 7

■ Setting of GP-Pro EX

◆ Communication Settings

To display the setup screen, from the [Project] menu, point to [System Settings] and select [Device/PLC].

The screenshot shows the 'Device/PLC 1' configuration window. It is divided into several sections:

- Summary:** Manufacturer: Azbil Corporation, Series: Controller(CPL), Port: COM1. Text Data Mode: 1. A 'Change Device/PLC' link is visible.
- Communication Settings:**
 - SI0 Type: RS232C, RS422/485(2wire), RS422/485(4wire)
 - Speed: 9600
 - Data Length: 7, 8
 - Parity: NONE, EVEN, ODD
 - Stop Bit: 1, 2
 - Flow Control: NONE, ER(DTR/CTS), XON/XOFF
 - Timeout: 3 (sec)
 - Retry: 2
 - Wait To Send: 10 (ms)
- RI / VCC:** RI, VCC. A note states: 'In the case of RS232C, you can select the 9th pin to RI (Input) or VCC (5V Power Supply). If you use the Digital's RS232C Isolation Unit, please select it to VCC.' A 'Default' button is present.
- Device-Specific Settings:** Allowable Number of Devices/PLCs: 31. An 'Add Device' link is shown.
- Device List:** A table with columns 'No.', 'Device Name', and 'Settings'. It contains one entry: No. 1, Device Name PLC1, Settings Series=SDC30/31, Device Address=1, Sub Address=0. An 'Add Indirect Device' button is on the right.

◆ Device Setting

To display the [Individual Device Settings] dialog box, from [Device-Specific Settings] in the [Device/PLC] window, select the external device and click [Settings] .

To connect multiple External Devices, from [Device-Specific Settings] in the [Device/PLC] window, click [Add Device] to add another External Device.

The screenshot shows the 'Individual Device Settings' dialog box for device PLC1. It contains the following fields and controls:

- Series: SDC30/31
- Text: Please reconfirm all of address settings that you are using if you have changed the series.
- Device Address: 1
- Sub Address: 0
- Buttons: Default, OK (O), Cancel

■ Settings of External Device

To configure communication settings for the External Device, use the ENT, DISP, MODE, Down and Up keys on the front of the Controller. You can change the communication settings only in READY mode. Switch the External Device to READY mode before setting.

Refer to your Controller manual for details.

◆ Procedure

- 1 In the basic display, press the MODE key twice. In the RUN/READY mode switching display that appears, change to READY mode.
- 2 In the basic display, press and hold the ENT and Down keys simultaneously for 3 seconds or more to display the setup items.
- 3 Press the Down/Up keys to select a setup item and press the ENT key.
- 4 Use the Down/Up keys to select a setting and press the ENT key.
- 5 Press the DISP key to move to the basic display.

◆ Settings

Setup Items	Settings
C31	1
C32	0
C33	0

NOTE

- The parameters to be set vary depending on the Controller. Refer to your Controller manual for details.

3.8 Setting Example 8

■ Setting of GP-Pro EX

◆ Communication Settings

To display the setup screen, from the [Project] menu, point to [System Settings] and select [Device/PLC].

The screenshot shows the 'Device/PLC 1' configuration window. It is divided into several sections:

- Summary:** Manufacturer: Azbil Corporation, Series: Controller(CPL), Port: COM1. Text Data Mode: 1.
- Communication Settings:**
 - SI0 Type: RS422/485(2wire)
 - Speed: 9600
 - Data Length: 8
 - Parity: EVEN
 - Stop Bit: 1
 - Flow Control: NONE
 - Timeout: 3 (sec)
 - Retry: 2
 - Wait To Send: 10 (ms)
- RI / VCC:** RI. A note states: "In the case of RS232C, you can select the 9th pin to RI (Input) or VCC (5V Power Supply). If you use the Digital's RS232C Isolation Unit, please select it to VCC."
- Device-Specific Settings:** Allowable Number of Devices/PLCs: 31. A table lists the device:

No.	Device Name	Settings
1	PLC1	Series=SDC30/31,Device Address=1,Sub Address=0

◆ Device Setting

To display the [Individual Device Settings] dialog box, from [Device-Specific Settings] in the [Device/PLC] window, select the external device and click [Settings] .

To connect multiple External Devices, from [Device-Specific Settings] in the [Device/PLC] window, click [Add Device] to add another External Device.

The 'Individual Device Settings' dialog box for PLC1 is shown. It contains the following fields and controls:

- Series: SDC30/31
- Device Address: 1
- Sub Address: 0
- Buttons: Default, OK (O), Cancel

A note in the dialog reads: "Please reconfirm all of address settings that you are using if you have changed the series."

■ Settings of External Device

To configure communication settings for the External Device, use the ENT, DISP, MODE, Down and Up keys on the front of the Controller. You can change the communication settings only in READY mode. Switch the External Device to READY mode before setting.

Refer to your Controller manual for details.

◆ Procedure

- 1 In the basic display, press the MODE key twice. In the RUN/READY mode switching display that appears, change to READY mode.
- 2 In the basic display, press and hold the ENT and Down keys simultaneously for 3 seconds or more to display the setup items.
- 3 Press the Down/Up keys to select a setup item and press the ENT key.
- 4 Use the Down/Up keys to select a setting and press the ENT key.
- 5 Press the DISP key to move to the basic display.

◆ Settings

Setup Items	Settings
C31	1
C32	0
C33	0

NOTE

- The parameters to be set vary depending on the Controller. Refer to your Controller manual for details.

3.9 Setting Example 9

■ Setting of GP-Pro EX

◆ Communication Settings

To display the setup screen, from the [Project] menu, point to [System Settings] and select [Device/PLC].

The screenshot shows the 'Device/PLC 1' configuration window. It is divided into several sections:

- Summary:** Manufacturer: Azbil Corporation, Series: Controller(CPL), Port: COM1. Text Data Mode: 1. A 'Change Device/PLC' link is visible.
- Communication Settings:**
 - SIQ Type: RS232C, RS422/485(2wire), RS422/485(4wire)
 - Speed: 9600
 - Data Length: 7, 8
 - Parity: NONE, EVEN, ODD
 - Stop Bit: 1, 2
 - Flow Control: NONE, ER(DTR/CTS), XON/XOFF
 - Timeout: 3 (sec)
 - Retry: 2
 - Wait To Send: 10 (ms)
- RI / VCC:** RI, VCC. A note states: 'In the case of RS232C, you can select the 9th pin to RI (Input) or VCC (5V Power Supply). If you use the Digital's RS232C Isolation Unit, please select it to VCC.' A 'Default' button is present.
- Device-Specific Settings:** Allowable Number of Devices/PLCs: 31. An 'Add Device' link is shown.
- Device List:** A table with columns 'No.', 'Device Name', and 'Settings'. It contains one entry: No. 1, Device Name PLC1, Settings Series=SDC35/36, Device Address=1, Sub Address=0. An 'Add Indirect Device' button is on the right.

◆ Device Setting

To display the [Individual Device Settings] dialog box, from [Device-Specific Settings] in the [Device/PLC] window, select the external device and click [Settings] .

To connect multiple External Devices, from [Device-Specific Settings] in the [Device/PLC] window, click [Add Device] to add another External Device.

The screenshot shows the 'Individual Device Settings' dialog box for 'PLC1'. It contains the following fields and controls:

- Series: SDC35/36
- Text: Please reconfirm all of address settings that you are using if you have changed the series.
- Device Address: 1
- Sub Address: 0
- Buttons: Default, OK (O), Cancel

■ Settings of External Device

To configure communication settings for the External Device, use the para, mode, enter, Down and Up keys on the front of the Controller. Refer to your Controller manual for details.

◆ Procedure

- 1 In the operation display, press and hold the para key (for 2 seconds) to move to the bank selection display.
- 2 In the bank selection display, press the enter key to move to the bank setup display.
- 3 Press the para key several times to display the desired setup item.
- 4 Press the enter key to blink the set value displayed.
- 5 Use the Down/Up keys to select a setting.
- 6 Press the enter key to fix the change.
- 7 Press the mode key to move to the operation display.

◆ Settings

Setup Items	Settings
C64	0
C65	1
C66	1
C67	1
C68	0
C69	0

NOTE

- The parameters to be set vary depending on the Controller. Refer to your Controller manual for details.

3.10 Setting Example 10

■ Setting of GP-Pro EX

◆ Communication Settings

To display the setup screen, from the [Project] menu, point to [System Settings] and select [Device/PLC].

Device/PLC 1

Summary [Change Device/PLC](#)

Manufacturer Series Port

Text Data Mode [Change](#)

Communication Settings

SI0 Type RS232C RS422/485(2wire) RS422/485(4wire)

Speed

Data Length 7 8

Parity NONE EVEN ODD

Stop Bit 1 2

Flow Control NONE ER(DTR/CTS) XON/XOFF

Timeout (sec)

Retry

Wait To Send (ms)

RI / VCC RI VCC

In the case of RS232C, you can select the 9th pin to RI (Input) or VCC (5V Power Supply). If you use the Digital's RS232C Isolation Unit, please select it to VCC.

[Default](#)

Device-Specific Settings

Allowable Number of Devices/PLCs 31 [Add Device](#)

No.	Device Name	Settings
1	PLC1	Series=SDC40A, Device Address=1, Sub Address=0

[Add Indirect Device](#)

◆ Device Setting

To display the [Individual Device Settings] dialog box, from [Device-Specific Settings] in the [Device/PLC] window, select the external device and click [Settings]  .

To connect multiple External Devices, from [Device-Specific Settings] in the [Device/PLC] window, click [Add Device] to add another External Device.

Individual Device Settings

PLC1

Series

Please reconfirm all of address settings that you are using if you have changed the series.

Device Address

Sub Address

[Default](#)

[OK \(O\)](#) [Cancel](#)

■ Settings of External Device

To configure communication settings for the External Device, use the PARA, ENT, DISP, Down and Up keys on the front of the Controller. You can change the communication settings only in READY mode. Switch the External Device to READY mode before setting.

Refer to your Controller manual for details.

◆ Procedure

- 1 In the basic display, press the PARA key to display PARA. Then press the ENT key to display rmy and move to READY mode.
- 2 In the basic display, press the PARA key several times to display SETUP.
- 3 Press the ENT key to display the setup items.
- 4 Press the Down/Up keys to select a setup item and press the ENT key.
- 5 Use the Down/Up keys to select a setting and press the ENT key.
- 6 Press the DISP key to move to the basic display.

◆ Settings

Setup Items	Settings
C84	1
C85	0

NOTE

- The parameters to be set vary depending on the Controller. Refer to your Controller manual for details.

3.11 Setting Example 11

■ Setting of GP-Pro EX

◆ Communication Settings

To display the setup screen, from the [Project] menu, point to [System Settings] and select [Device/PLC].

The screenshot shows the 'Device/PLC 1' configuration window. It is divided into several sections:

- Summary:** Manufacturer: Azbil Corporation, Series: Controller(CPL), Port: COM1. Text Data Mode: 1. A 'Change Device/PLC' link is visible.
- Communication Settings:**
 - SI0 Type: RS232C, RS422/485(2wire), RS422/485(4wire)
 - Speed: 9600
 - Data Length: 7, 8
 - Parity: NONE, EVEN, ODD
 - Stop Bit: 1, 2
 - Flow Control: NONE, ER(DTR/CTS), XON/XOFF
 - Timeout: 3 (sec)
 - Retry: 2
 - Wait To Send: 10 (ms)
- RI / VCC:** RI, VCC. A note states: 'In the case of RS232C, you can select the 9th pin to RI (Input) or VCC (5V Power Supply). If you use the Digital's RS232C Isolation Unit, please select it to VCC.' A 'Default' button is present.
- Device-Specific Settings:** Allowable Number of Devices/PLCs: 31. An 'Add Device' link is shown.
- Device List:** A table with columns 'No.', 'Device Name', and 'Settings'. It contains one entry: No. 1, Device Name PLC1, Settings Series=SDC40A, Device Address=1, Sub Address=0. An 'Add Indirect Device' button is on the right.

◆ Device Setting

To display the [Individual Device Settings] dialog box, from [Device-Specific Settings] in the [Device/PLC] window, select the external device and click [Settings] .

To connect multiple External Devices, from [Device-Specific Settings] in the [Device/PLC] window, click [Add Device] to add another External Device.

The screenshot shows the 'Individual Device Settings' dialog box for device PLC1. It contains the following fields and controls:

- Series: SDC40A (dropdown menu)
- Text: Please reconfirm all of address settings that you are using if you have changed the series.
- Device Address: 1 (spin box)
- Sub Address: 0 (spin box)
- Buttons: Default, OK (O), Cancel

■ Settings of External Device

To configure communication settings for the External Device, use the PARA, ENT, DISP, Down and Up keys on the front of the Controller. You can change the communication settings only in READY mode. Switch the External Device to READY mode before setting.

Refer to your Controller manual for details.

◆ Procedure

- 1 In the basic display, press the PARA key to display PARA. Then press the ENT key to display rmy and move to READY mode.
- 2 In the basic display, press the PARA key several times to display SETUP.
- 3 Press the ENT key to display the setup items.
- 4 Press the Down/Up keys to select a setup item and press the ENT key.
- 5 Use the Down/Up keys to select a setting and press the ENT key.
- 6 Press the DISP key to move to the basic display.

◆ Settings

Setup Items	Settings
C84	1
C85	0

NOTE

- The parameters to be set vary depending on the Controller. Refer to your Controller manual for details.

3.12 Setting Example 12

■ Setting of GP-Pro EX

◆ Communication Settings

To display the setup screen, from the [Project] menu, point to [System Settings] and select [Device/PLC].

Device/PLC 1

Summary [Change Device/PLC](#)

Manufacturer Series Port

Text Data Mode [Change](#)

Communication Settings

SI0 Type RS232C RS422/485(2wire) RS422/485(4wire)

Speed

Data Length 7 8

Parity NONE EVEN ODD

Stop Bit 1 2

Flow Control NONE ER(DTR/CTS) XON/XOFF

Timeout (sec)

Retry

Wait To Send (ms)

RI / VCC RI VCC

In the case of RS232C, you can select the 9th pin to RI (Input) or VCC (5V Power Supply). If you use the Digital's RS232C Isolation Unit, please select it to VCC.

Device-Specific Settings

Allowable Number of Devices/PLCs 31 [Add Device](#)

No.	Device Name	Settings
<input type="button" value="Add"/> 1	<input type="text" value="PLC1"/>	<input type="text" value="Series=SDC40A,Device Address=1,Sub Address=0"/>

◆ Device Setting

To display the [Individual Device Settings] dialog box, from [Device-Specific Settings] in the [Device/PLC] window, select the external device and click [Settings]  .

To connect multiple External Devices, from [Device-Specific Settings] in the [Device/PLC] window, click [Add Device] to add another External Device.

Individual Device Settings

PLC1

Series

Please reconfirm all of address settings that you are using if you have changed the series.

Device Address

Sub Address

■ Settings of External Device

To configure communication settings for the External Device, use the PARA, ENT, DISP, Down and Up keys on the front of the Controller. You can change the communication settings only in READY mode. Switch the External Device to READY mode before setting.

Refer to your Controller manual for details.

◆ Procedure

- 1 In the basic display, press the PARA key to display PARA. Then press the ENT key to display rmy and move to READY mode.
- 2 In the basic display, press the PARA key several times to display SETUP.
- 3 Press the ENT key to display the setup items.
- 4 Press the Down/Up keys to select a setup item and press the ENT key.
- 5 Use the Down/Up keys to select a setting and press the ENT key.
- 6 Press the DISP key to move to the basic display.

◆ Settings

Setup Items	Settings
C84	1
C85	0

NOTE

- The parameters to be set vary depending on the Controller. Refer to your Controller manual for details.

3.13 Setting Example 13

■ Setting of GP-Pro EX

◆ Communication Settings

To display the setup screen, from the [Project] menu, point to [System Settings] and select [Device/PLC].

The screenshot shows the 'Device/PLC 1' configuration window. It is divided into several sections:

- Summary:** Manufacturer: Azbil Corporation, Series: Controller(CPL), Port: COM1. Text Data Mode: 1. A 'Change Device/PLC' link is visible.
- Communication Settings:**
 - SI0 Type: RS232C, RS422/485(2wire), RS422/485(4wire)
 - Speed: 9600
 - Data Length: 7, 8
 - Parity: NONE, EVEN, ODD
 - Stop Bit: 1, 2
 - Flow Control: NONE, ER(DTR/CTS), XON/XOFF
 - Timeout: 3 (sec)
 - Retry: 2
 - Wait To Send: 10 (ms)
- RI / VCC:** RI, VCC. A note states: 'In the case of RS232C, you can select the 9th pin to RI (Input) or VCC (5V Power Supply). If you use the Digital's RS232C Isolation Unit, please select it to VCC.' A 'Default' button is present.
- Device-Specific Settings:** Allowable Number of Devices/PLCs: 31. An 'Add Device' link is available.
- Device List:** A table with columns 'No.', 'Device Name', and 'Settings'. It contains one entry: No. 1, Device Name PLC1, Settings Series=SDC40B, Device Address=1, Sub Address=0. An 'Add Indirect Device' button is on the right.

◆ Device Setting

To display the [Individual Device Settings] dialog box, from [Device-Specific Settings] in the [Device/PLC] window, select the external device and click [Settings] .

To connect multiple External Devices, from [Device-Specific Settings] in the [Device/PLC] window, click [Add Device] to add another External Device.

The 'Individual Device Settings' dialog box is shown for device PLC1. It contains the following fields and controls:

- Series: SDC40B (dropdown menu)
- Text: Please reconfirm all of address settings that you are using if you have changed the series.
- Device Address: 1 (spin box)
- Sub Address: 0 (spin box)
- Buttons: Default, OK (O), Cancel

■ Settings of External Device

To configure communication settings for the External Device, use the PARA, ENT, DISP, Down and Up keys on the front of the Controller. Refer to your Controller manual for details.

◆ Procedure

- 1 In the basic display, press the PARA key to move to setup mode.
- 2 Press the ENT key to display the setup items.
- 3 Press the Down/Up keys to select a setup item and press the ENT key.
- 4 Use the Down/Up keys to select a setting and press the ENT key.
- 5 Press the DISP key to move to the basic display.

◆ Settings

Setup Items	Settings
C25	1
C26	0
C27	0

NOTE

- The parameters to be set vary depending on the Controller. Refer to your Controller manual for details.

3.14 Setting Example 14

■ Setting of GP-Pro EX

◆ Communication Settings

To display the setup screen, from the [Project] menu, point to [System Settings] and select [Device/PLC].

Device/PLC 1

Summary [Change Device/PLC](#)

Manufacturer Series Port

Text Data Mode [Change](#)

Communication Settings

SID Type RS232C RS422/485(2wire) RS422/485(4wire)

Speed

Data Length 7 8

Parity NONE EVEN ODD

Stop Bit 1 2

Flow Control NONE ER(DTR/CTS) XON/XOFF

Timeout (sec)

Retry

Wait To Send (ms)

RI / VCC RI VCC

In the case of RS232C, you can select the 9th pin to RI (Input) or VCC (5V Power Supply). If you use the Digital's RS232C Isolation Unit, please select it to VCC.

Device-Specific Settings

Allowable Number of Devices/PLCs 31 [Add Device](#)

No.	Device Name	Settings
1	PLC1	Series=SDC40B, Device Address=1, Sub Address=0

◆ Device Setting

To display the [Individual Device Settings] dialog box, from [Device-Specific Settings] in the [Device/PLC] window, select the external device and click [Settings] .

To connect multiple External Devices, from [Device-Specific Settings] in the [Device/PLC] window, click [Add Device] to add another External Device.

Individual Device Settings

PLC1

Series

Please reconfirm all of address settings that you are using if you have changed the series.

Device Address

Sub Address

■ Settings of External Device

To configure communication settings for the External Device, use the PARA, ENT, DISP, Down and Up keys on the front of the Controller. Refer to your Controller manual for details.

◆ Procedure

- 1 In the basic display, press the PARA key to move to setup mode.
- 2 Press the ENT key to display the setup items.
- 3 Press the Down/Up keys to select a setup item and press the ENT key.
- 4 Use the Down/Up keys to select a setting and press the ENT key.
- 5 Press the DISP key to move to the basic display.

◆ Settings

Setup Items	Settings
C25	1
C26	0
C27	0

NOTE

- The parameters to be set vary depending on the Controller. Refer to your Controller manual for details.

3.15 Setting Example 15

■ Setting of GP-Pro EX

◆ Communication Settings

To display the setup screen, from the [Project] menu, point to [System Settings] and select [Device/PLC].

The screenshot shows the 'Device/PLC 1' configuration window. It is divided into several sections:

- Summary:** Manufacturer: Azbil Corporation, Series: Controller(CPL), Port: COM1. Text Data Mode: 1. A 'Change Device/PLC' link is visible.
- Communication Settings:**
 - SI0 Type: RS232C, RS422/485(2wire), RS422/485(4wire)
 - Speed: 9600
 - Data Length: 7, 8
 - Parity: NONE, EVEN, ODD
 - Stop Bit: 1, 2
 - Flow Control: NONE, ER(DTR/CTS), XON/XOFF
 - Timeout: 3 (sec)
 - Retry: 2
 - Wait To Send: 10 (ms)
- RI / VCC:** RI, VCC. A note states: 'In the case of RS232C, you can select the 9th pin to RI (Input) or VCC (5V Power Supply). If you use the Digital's RS232C Isolation Unit, please select it to VCC.' A 'Default' button is present.
- Device-Specific Settings:** Allowable Number of Devices/PLCs: 31. An 'Add Device' link is available.
- Device List:** A table with columns 'No.', 'Device Name', and 'Settings'. It contains one entry: No. 1, Device Name PLC1, Settings Series=SDC40B, Device Address=1, Sub Address=0. An 'Add Indirect Device' button is on the right.

◆ Device Setting

To display the [Individual Device Settings] dialog box, from [Device-Specific Settings] in the [Device/PLC] window, select the external device and click [Settings] .

To connect multiple External Devices, from [Device-Specific Settings] in the [Device/PLC] window, click [Add Device] to add another External Device.

The screenshot shows the 'Individual Device Settings' dialog box for device PLC1. It contains the following fields and controls:

- Series: SDC40B (dropdown menu)
- Text: Please reconfirm all of address settings that you are using if you have changed the series.
- Device Address: 1 (spin box)
- Sub Address: 0 (spin box)
- Buttons: Default, OK (O), Cancel

■ Settings of External Device

To configure communication settings for the External Device, use the PARA, ENT, DISP, Down and Up keys on the front of the Controller. Refer to your Controller manual for details.

◆ Procedure

- 1 In the basic display, press the PARA key to move to setup mode.
- 2 Press the ENT key to display the setup items.
- 3 Press the Down/Up keys to select a setup item and press the ENT key.
- 4 Use the Down/Up keys to select a setting and press the ENT key.
- 5 Press the DISP key to move to the basic display.

◆ Settings

Setup Items	Settings
C25	1
C26	0
C27	0

NOTE

- The parameters to be set vary depending on the Controller. Refer to your Controller manual for details.

3.16 Setting Example 16

■ Setting of GP-Pro EX

◆ Communication Settings

To display the setup screen, from the [Project] menu, point to [System Settings] and select [Device/PLC].

The screenshot shows the 'Device/PLC 1' configuration window. It is divided into several sections:

- Summary:** Manufacturer: Azbil Corporation, Series: Controller(CPL), Port: COM1. Text Data Mode: 1. A 'Change Device/PLC' link is visible.
- Communication Settings:**
 - SI0 Type: RS232C, RS422/485(2wire), RS422/485(4wire)
 - Speed: 9600
 - Data Length: 7, 8
 - Parity: NONE, EVEN, ODD
 - Stop Bit: 1, 2
 - Flow Control: NONE, ER(DTR/CTS), XON/XOFF
 - Timeout: 3 (sec)
 - Retry: 2
 - Wait To Send: 10 (ms)
- RI / VCC:** RI, VCC. A note states: 'In the case of RS232C, you can select the 9th pin to RI (Input) or VCC (5V Power Supply). If you use the Digital's RS232C Isolation Unit, please select it to VCC.' A 'Default' button is present.
- Device-Specific Settings:** Allowable Number of Devices/PLCs: 31. An 'Add Device' link is available.
- Device List:** A table with columns 'No.', 'Device Name', and 'Settings'. It contains one entry: No. 1, Device Name PLC1, Settings Series=SDC40G, Device Address=1, Sub Address=0. An 'Add Indirect Device' button is on the right.

◆ Device Setting

To display the [Individual Device Settings] dialog box, from [Device-Specific Settings] in the [Device/PLC] window, select the external device and click [Settings] .

To connect multiple External Devices, from [Device-Specific Settings] in the [Device/PLC] window, click [Add Device] to add another External Device.

The 'Individual Device Settings' dialog box is shown for device PLC1. It contains the following fields and controls:

- Series: SDC40G (dropdown menu)
- Text: 'Please reconfirm all of address settings that you are using if you have changed the series.'
- Device Address: 1 (spin box)
- Sub Address: 0 (spin box)
- Buttons: Default, OK (O), Cancel

■ Settings of External Device

To configure communication settings for the External Device, use the PARA, ENT, DISP, Down and Up keys on the front of the Controller. You can change the communication settings only in READY mode. Switch the External Device to READY mode before setting.

Refer to your Controller manual for details.

◆ Procedure

- 1 In the basic display, press the PARA key to display PARA. Then press the ENT key to display rmry and move to READY mode.
- 2 In the basic display, press the PARA key several times to display SETUP.
- 3 Press the ENT key to display the setup items.
- 4 Press the Down/Up keys to select a setup item and press the ENT key.
- 5 Use the Down/Up keys to select a setting and press the ENT key.
- 6 Press the DISP key to move to the basic display.

◆ Settings

Setup Items	Settings
C25	1
C26	0
C27	0

NOTE

- The parameters to be set vary depending on the Controller. Refer to your Controller manual for details.

3.17 Setting Example 17

■ Setting of GP-Pro EX

◆ Communication Settings

To display the setup screen, from the [Project] menu, point to [System Settings] and select [Device/PLC].

The screenshot shows the 'Device/PLC 1' configuration window. It has a 'Summary' section with fields for 'Manufacturer' (Azbil Corporation), 'Series' (Controller(CPL)), and 'Port' (COM1). Below this is the 'Communication Settings' section with radio buttons for 'RS232C', 'RS422/485(2wire)', and 'RS422/485(4wire)'. Other settings include 'Speed' (9600), 'Data Length' (8), 'Parity' (EVEN), 'Stop Bit' (1), 'Flow Control' (NONE), 'Timeout' (3 sec), 'Retry' (2), and 'Wait To Send' (10 ms). There is a section for 'RI / VCC' with radio buttons for 'RI' and 'VCC', and a 'Default' button. The 'Device-Specific Settings' section shows 'Allowable Number of Devices/PLCs' as 31 and a table with one device: 'PLC1' with settings 'Series=SDC40G, Device Address=1, Sub Address=0'. There are 'Add Device' and 'Add Indirect Device' buttons.

◆ Device Setting

To display the [Individual Device Settings] dialog box, from [Device-Specific Settings] in the [Device/PLC] window, select the external device and click [Settings] .

To connect multiple External Devices, from [Device-Specific Settings] in the [Device/PLC] window, click [Add Device] to add another External Device.

The screenshot shows the 'Individual Device Settings' dialog box for 'PLC1'. It has a 'Series' dropdown menu set to 'SDC40G'. Below this is a warning: 'Please reconfirm all of address settings that you are using if you have changed the series.' There are two spin boxes: 'Device Address' set to 1 and 'Sub Address' set to 0. At the bottom, there are 'Default', 'OK (O)', and 'Cancel' buttons.

■ Settings of External Device

To configure communication settings for the External Device, use the PARA, ENT, DISP, Down and Up keys on the front of the Controller. You can change the communication settings only in READY mode. Switch the External Device to READY mode before setting.

Refer to your Controller manual for details.

◆ Procedure

- 1 In the basic display, press the PARA key to display PARA. Then press the ENT key to display rmy and move to READY mode.
- 2 In the basic display, press the PARA key several times to display SETUP.
- 3 Press the ENT key to display the setup items.
- 4 Press the Down/Up keys to select a setup item and press the ENT key.
- 5 Use the Down/Up keys to select a setting and press the ENT key.
- 6 Press the DISP key to move to the basic display.

◆ Settings

Setup Items	Settings
C25	1
C26	0
C27	0

NOTE

- The parameters to be set vary depending on the Controller. Refer to your Controller manual for details.

3.18 Setting Example 18

■ Setting of GP-Pro EX

◆ Communication Settings

To display the setup screen, from the [Project] menu, point to [System Settings] and select [Device/PLC].

The screenshot shows the 'Device/PLC 1' configuration window. It is divided into several sections:

- Summary:** Manufacturer: Azbil Corporation, Series: Controller(CPL), Port: COM1. Text Data Mode: 1. A 'Change Device/PLC' link is visible.
- Communication Settings:**
 - SI0 Type: RS232C, RS422/485(2wire), RS422/485(4wire)
 - Speed: 9600
 - Data Length: 7, 8
 - Parity: NONE, EVEN, ODD
 - Stop Bit: 1, 2
 - Flow Control: NONE, ER(DTR/CTS), XON/XOFF
 - Timeout: 3 (sec)
 - Retry: 2
 - Wait To Send: 10 (ms)
- RI / VCC:** RI, VCC. A note states: 'In the case of RS232C, you can select the 9th pin to RI (Input) or VCC (5V Power Supply). If you use the Digital's RS232C Isolation Unit, please select it to VCC.' A 'Default' button is present.
- Device-Specific Settings:** Allowable Number of Devices/PLCs: 31. An 'Add Device' link is available.
- Device List:** A table with columns 'No.', 'Device Name', and 'Settings'. The first entry is '1', 'PLC1', and 'Series=DMC10,Device Address=1,Sub Address=0'. An 'Add Indirect Device' button is on the right.

◆ Device Setting

To display the [Individual Device Settings] dialog box, from [Device-Specific Settings] in the [Device/PLC] window, select the external device and click [Settings] .

To connect multiple External Devices, from [Device-Specific Settings] in the [Device/PLC] window, click [Add Device] to add another External Device.

The screenshot shows the 'Individual Device Settings' dialog box for 'PLC1'. It contains the following fields and controls:

- Series: DMC10
- Warning: Please reconfirm all of address settings that you are using if you have changed the series.
- Device Address: 1
- Sub Address: 0
- Buttons: Default, OK (O), Cancel

■ Settings of External Device

Use the ladder software to configure communication settings for the External Device. (Operation confirmed using the the Smart Loader Package SLP-D10 V3.0.1.) Set the device address of the External Device using the rotary switch on the front of the Controller.

Refer to your Controller manual for details.

◆ Procedure

- 1 Set the device address using the device address setting rotary switch on the front of the Controller.
After setting the address, reboot the External Device.
- 2 Click [Set] in the ladder software to display the setting screen.
- 3 Click [Model Setting] from the menu and select the model No. of the External Device.
- 4 Click [Environmental Setting] from the menu and configure the setup transfer settings.
- 5 Select [Communication] from [Basic Function] in the tree view and configure the communication settings.
- 6 Transfer the settings to the External Device.
When the writing is complete, reboot the External Device.

◆ Settings

Setup Items	Settings
Speed	3
Data format	0
Min. communication response time	1
Additional value of min. communication response time	0
CPL/MODBUSswitching	0
Memory protection	0

NOTE

- The parameters to be set vary depending on the Controller. Refer to your Controller manual for details.

3.19 Setting Example 19

■ Setting of GP-Pro EX

◆ Communication Settings

To display the setup screen, from the [Project] menu, point to [System Settings] and select [Device/PLC].

The screenshot shows the 'Device/PLC 1' configuration window. It is divided into several sections:

- Summary:** Manufacturer: Azbil Corporation, Series: Controller(CPL), Port: COM1. Text Data Mode: 1. A 'Change Device/PLC' link is visible.
- Communication Settings:**
 - SI0 Type: RS232C, RS422/485(2wire), RS422/485(4wire)
 - Speed: 9600
 - Data Length: 7, 8
 - Parity: NONE, EVEN, ODD
 - Stop Bit: 1, 2
 - Flow Control: NONE, ER(DTR/CTS), XON/XOFF
 - Timeout: 3 (sec)
 - Retry: 2
 - Wait To Send: 10 (ms)
- RI / VCC:** RI, VCC. A note states: 'In the case of RS232C, you can select the 9th pin to RI (Input) or VCC (5V Power Supply). If you use the Digital's RS232C Isolation Unit, please select it to VCC.' A 'Default' button is present.
- Device-Specific Settings:** Allowable Number of Devices/PLCs: 31. An 'Add Device' link is shown.
- Device List:** A table with columns 'No.', 'Device Name', and 'Settings'. It contains one entry: No. 1, Device Name PLC1, Settings Series=DCP31, Device Address=1, Sub Address=0. An 'Add Indirect Device' button is on the right.

◆ Device Setting

To display the [Individual Device Settings] dialog box, from [Device-Specific Settings] in the [Device/PLC] window, select the external device and click [Settings] .

To connect multiple External Devices, from [Device-Specific Settings] in the [Device/PLC] window, click [Add Device] to add another External Device.

The screenshot shows the 'Individual Device Settings' dialog box for PLC1. It contains the following fields and controls:

- Series: DCP31 (dropdown menu)
- Text: 'Please reconfirm all of address settings that you are using if you have changed the series.'
- Device Address: 1 (spin box)
- Sub Address: 0 (spin box)
- Buttons: Default, OK (O), Cancel

■ Settings of External Device

To configure communication settings for the External Device, use the FUNC, PARA, ENT, DISP, Down and Up keys on the front of the Controller. Refer to your Controller manual for details.

◆ Procedure

- 1 In the basic display, press the PARA key while holding down the FUNC key to move to the setting group selection screen.
- 2 Press the PARA key several times to display the setup data setting group, and press the ENT key.
- 3 Press the Down/Up keys several times to select a setup item and press the ENT key.
- 4 Use the Down/Up keys to select a setting and press the ENT key.
- 5 Press the DISP key to move to the basic display.

◆ Settings

Setup Items	Settings
C84	1
C85	0
C93	0

NOTE

- The parameters to be set vary depending on the Controller. Refer to your Controller manual for details.

3.20 Setting Example 20

■ Setting of GP-Pro EX

◆ Communication Settings

To display the setup screen, from the [Project] menu, point to [System Settings] and select [Device/PLC].

The screenshot shows the 'Device/PLC 1' configuration window. It has a 'Summary' section with fields for 'Manufacturer' (Azbil Corporation), 'Series' (Controller(CPL)), and 'Port' (COM1). Below this is the 'Communication Settings' section with radio buttons for 'RS232C', 'RS422/485(2wire)', and 'RS422/485(4wire)'. The 'Speed' is set to 9600, 'Data Length' to 8, 'Parity' to EVEN, and 'Stop Bit' to 1. 'Flow Control' is set to NONE. 'Timeout' is 3 seconds and 'Retry' is 2. 'Wait To Send' is 10 ms. There is a section for 'RI / VCC' with radio buttons for 'RI' and 'VCC', and a 'Default' button. The 'Device-Specific Settings' section shows 'Allowable Number of Devices/PLCs' as 31 and a table with one device: '1 | PLC1 | Series=DCP31, Device Address=1, Sub Address=0'. There is an 'Add Device' button and an 'Add Indirect Device' button.

◆ Device Setting

To display the [Individual Device Settings] dialog box, from [Device-Specific Settings] in the [Device/PLC] window, select the external device and click [Settings] .

To connect multiple External Devices, from [Device-Specific Settings] in the [Device/PLC] window, click [Add Device] to add another External Device.

The screenshot shows the 'Individual Device Settings' dialog box for 'PLC1'. It has a 'Series' dropdown menu set to 'DCP31'. Below this is a warning: 'Please reconfirm all of address settings that you are using if you have changed the series.' There are two spin boxes: 'Device Address' set to 1 and 'Sub Address' set to 0. At the bottom, there are 'Default', 'OK (O)', and 'Cancel' buttons.

■ Settings of External Device

To configure communication settings for the External Device, use the FUNC, PARA, ENT, DISP, Down and Up keys on the front of the Controller. Refer to your Controller manual for details.

◆ Procedure

- 1 In the basic display, press the PARA key while holding down the FUNC key to move to the setting group selection screen.
- 2 Press the PARA key several times to display the setup data setting group, and press the ENT key.
- 3 Press the Down/Up keys several times to select a setup item and press the ENT key.
- 4 Use the Down/Up keys to select a setting and press the ENT key.
- 5 Press the DISP key to move to the basic display.

◆ Settings

Setup Items	Settings
C84	1
C85	0
C93	0

NOTE

- The parameters to be set vary depending on the Controller. Refer to your Controller manual for details.

3.21 Setting Example 21

■ Setting of GP-Pro EX

◆ Communication Settings

To display the setup screen, from the [Project] menu, point to [System Settings] and select [Device/PLC].

The screenshot shows the 'Device/PLC 1' configuration window. It is divided into several sections:

- Summary:** Manufacturer: Azbil Corporation, Series: Controller(CPL), Port: COM1. Text Data Mode: 1. A 'Change Device/PLC' link is visible.
- Communication Settings:**
 - SI0 Type: RS232C, RS422/485(2wire), RS422/485(4wire)
 - Speed: 9600
 - Data Length: 7, 8
 - Parity: NONE, EVEN, ODD
 - Stop Bit: 1, 2
 - Flow Control: NONE, ER(DTR/CTS), XON/XOFF
 - Timeout: 3 (sec)
 - Retry: 2
 - Wait To Send: 10 (ms)
- RI / VCC:** RI, VCC. A note states: 'In the case of RS232C, you can select the 9th pin to RI (Input) or VCC (5V Power Supply). If you use the Digital's RS232C Isolation Unit, please select it to VCC.' A 'Default' button is present.
- Device-Specific Settings:** Allowable Number of Devices/PLCs: 31. An 'Add Device' link is shown.
- Device List:** A table with columns 'No.', 'Device Name', and 'Settings'. The first entry is '1', 'PLC1', and 'Series=DCP32,Device Address=1,Sub Address=0'. An 'Add Indirect Device' button is on the right.

◆ Device Setting

To display the [Individual Device Settings] dialog box, from [Device-Specific Settings] in the [Device/PLC] window, select the external device and click [Settings] .

To connect multiple External Devices, from [Device-Specific Settings] in the [Device/PLC] window, click [Add Device] to add another External Device.

The screenshot shows the 'Individual Device Settings' dialog box for 'PLC1'. It contains the following fields and controls:

- Series: DCP32
- Text: Please reconfirm all of address settings that you are using if you have changed the series.
- Device Address: 1
- Sub Address: 0
- Buttons: Default, OK (O), Cancel

■ Settings of External Device

To configure communication settings for the External Device, use the FUNC, PARA, ENT, DISP, Down and Up keys on the front of the Controller. Refer to your Controller manual for details.

◆ Procedure

- 1 In the basic display, press the PARA key while holding down the FUNC key to move to the setting group selection screen.
- 2 Press the PARA key several times to display the setup data setting group, and press the ENT key.
- 3 Press the Down/Up keys several times to select a setup item and press the ENT key.
- 4 Use the Down/Up keys to select a setting and press the ENT key.
- 5 Press the DISP key to move to the basic display.

◆ Settings

Setup Items	Settings
C84	1
C85	0
C93	0

NOTE

- The parameters to be set vary depending on the Controller. Refer to your Controller manual for details.

3.22 Setting Example 22

■ Setting of GP-Pro EX

◆ Communication Settings

To display the setup screen, from the [Project] menu, point to [System Settings] and select [Device/PLC].

The screenshot shows the 'Device/PLC 1' configuration window. It is divided into several sections:

- Summary:** Manufacturer: Azbil Corporation, Series: Controller(CPL), Port: COM1. Text Data Mode: 1. A 'Change Device/PLC' link is visible.
- Communication Settings:**
 - SI0 Type: RS232C, RS422/485(2wire), RS422/485(4wire)
 - Speed: 9600
 - Data Length: 7, 8
 - Parity: NONE, EVEN, ODD
 - Stop Bit: 1, 2
 - Flow Control: NONE, ER(DTR/CTS), XON/XOFF
 - Timeout: 3 (sec)
 - Retry: 2
 - Wait To Send: 10 (ms)
- RI / VCC:** RI, VCC. A note states: 'In the case of RS232C, you can select the 9th pin to RI (Input) or VCC (5V Power Supply). If you use the Digital's RS232C Isolation Unit, please select it to VCC.' A 'Default' button is present.
- Device-Specific Settings:** Allowable Number of Devices/PLCs: 31. An 'Add Device' link is available.
- Device List:** A table with columns 'No.', 'Device Name', and 'Settings'. The first entry is '1', 'PLC1', and 'Series=DCP32,Device Address=1,Sub Address=0'. An 'Add Indirect Device' button is on the right.

◆ Device Setting

To display the [Individual Device Settings] dialog box, from [Device-Specific Settings] in the [Device/PLC] window, select the external device and click [Settings] .

To connect multiple External Devices, from [Device-Specific Settings] in the [Device/PLC] window, click [Add Device] to add another External Device.

The screenshot shows the 'Individual Device Settings' dialog box for 'PLC1'. It contains the following fields and controls:

- Series: DCP32 (dropdown menu)
- Text: 'Please reconfirm all of address settings that you are using if you have changed the series.'
- Device Address: 1 (spin box)
- Sub Address: 0 (spin box)
- Buttons: Default, OK (O), Cancel

■ Settings of External Device

To configure communication settings for the External Device, use the FUNC, PARA, ENT, DISP, Down and Up keys on the front of the Controller. Refer to your Controller manual for details.

◆ Procedure

- 1 In the basic display, press the PARA key while holding down the FUNC key to move to the setting group selection screen.
- 2 Press the PARA key several times to display the setup data setting group, and press the ENT key.
- 3 Press the Down/Up keys several times to select a setup item and press the ENT key.
- 4 Use the Down/Up keys to select a setting and press the ENT key.
- 5 Press the DISP key to move to the basic display.

◆ Settings

Setup Items	Settings
C84	1
C85	0
C93	0

NOTE

- The parameters to be set vary depending on the Controller. Refer to your Controller manual for details.

3.23 Setting Example 23

■ Setting of GP-Pro EX

◆ Communication Settings

To display the setup screen, from the [Project] menu, point to [System Settings] and select [Device/PLC].

The screenshot shows the 'Device/PLC 1' configuration window. It is divided into several sections:

- Summary:** Manufacturer: Azbil Corporation, Series: Controller(CPL), Port: COM1. Text Data Mode: 1. A 'Change Device/PLC' link is visible.
- Communication Settings:**
 - SI0 Type: RS232C, RS422/485(2wire), RS422/485(4wire)
 - Speed: 9600
 - Data Length: 7, 8
 - Parity: NONE, EVEN, ODD
 - Stop Bit: 1, 2
 - Flow Control: NONE, ER(DTR/CTS), XON/XOFF
 - Timeout: 3 (sec)
 - Retry: 2
 - Wait To Send: 10 (ms)
- RI / VCC:** RI, VCC. A note states: 'In the case of RS232C, you can select the 9th pin to RI (Input) or VCC (5V Power Supply). If you use the Digital's RS232C Isolation Unit, please select it to VCC.' A 'Default' button is present.
- Device-Specific Settings:** Allowable Number of Devices/PLCs: 31. An 'Add Device' link is available.
- Device List:** A table with columns 'No.', 'Device Name', and 'Settings'. It contains one entry: No. 1, Device Name PLC1, Settings Series=DCP551, Device Address=1, Sub Address=0. An 'Add Indirect Device' button is on the right.

◆ Device Setting

To display the [Individual Device Settings] dialog box, from [Device-Specific Settings] in the [Device/PLC] window, select the external device and click [Settings] .

To connect multiple External Devices, from [Device-Specific Settings] in the [Device/PLC] window, click [Add Device] to add another External Device.

The screenshot shows the 'Individual Device Settings' dialog box for PLC1. It contains the following fields and controls:

- Series: DCP551 (dropdown menu)
- Text: Please reconfirm all of address settings that you are using if you have changed the series.
- Device Address: 1 (spin box)
- Sub Address: 0 (spin box)
- Buttons: Default, OK (O), Cancel

■ Settings of External Device

To configure communication settings for the External Device, use the PROG, RUN/HOLD, SETUP, ENT, DISP, Down and Up keys on the front of the Controller. You can change the communication settings only in READY mode. Switch the External Device to READY mode before setting.

Refer to your Controller manual for details.

◆ Procedure

- 1 Press the RUN/HOLD key while holding down the PROG key to move to READY mode.
- 2 In the basic display, press the SETUP key to move to the setup group.
- 3 Press the Down/Up keys several times to select a setup item and press the ENT key.
- 4 Use the Down/Up keys to select a setting and press the ENT key.
- 5 Press the DISP key to move to the basic display.

◆ Settings

Setup Items	Settings
C76	1
C77	0
C78	0
C79	0
C80	1
C97	0

NOTE

- The parameters to be set vary depending on the Controller. Refer to your Controller manual for details.

3.24 Setting Example 24

■ Setting of GP-Pro EX

◆ Communication Settings

To display the setup screen, from the [Project] menu, point to [System Settings] and select [Device/PLC].

Device/PLC 1

Summary [Change Device/PLC](#)

Manufacturer Series Port

Text Data Mode [Change](#)

Communication Settings

SID Type RS232C RS422/485(2wire) RS422/485(4wire)

Speed

Data Length 7 8

Parity NONE EVEN ODD

Stop Bit 1 2

Flow Control NONE ER(DTR/CTS) XON/XOFF

Timeout (sec)

Retry

Wait To Send (ms)

RI / VCC RI VCC

In the case of RS232C, you can select the 9th pin to RI (Input) or VCC (5V Power Supply). If you use the Digital's RS232C Isolation Unit, please select it to VCC.

[Default](#)

Device-Specific Settings

Allowable Number of Devices/PLCs 31 [Add Device](#)

No.	Device Name	Settings
1	PLC1	Series=DCP551, Device Address=1, Sub Address=0

[Add Indirect Device](#)

◆ Device Setting

To display the [Individual Device Settings] dialog box, from [Device-Specific Settings] in the [Device/PLC] window, select the external device and click [Settings] .

To connect multiple External Devices, from [Device-Specific Settings] in the [Device/PLC] window, click [Add Device] to add another External Device.

Individual Device Settings

PLC1

Series

Please reconfirm all of address settings that you are using if you have changed the series.

Device Address

Sub Address

[Default](#)

[OK \(O\)](#) [Cancel](#)

■ Settings of External Device

To configure communication settings for the External Device, use the PROG, RUN/HOLD, SETUP, ENT, DISP, Down and Up keys on the front of the Controller. You can change the communication settings only in READY mode. Switch the External Device to READY mode before setting.

Refer to your Controller manual for details.

◆ Procedure

- 1 Press the RUN/HOLD key while holding down the PROG key to move to READY mode.
- 2 In the basic display, press the SETUP key to move to the setup group.
- 3 Press the Down/Up keys several times to select a setup item and press the ENT key.
- 4 Use the Down/Up keys to select a setting and press the ENT key.
- 5 Press the DISP key to move to the basic display.

◆ Settings

Setup Items	Settings
C76	1
C77	0
C78	0
C79	0
C80	0
C97	0

NOTE

- The parameters to be set vary depending on the Controller. Refer to your Controller manual for details.

3.25 Setting Example 25

■ Setting of GP-Pro EX

◆ Communication Settings

To display the setup screen, from the [Project] menu, point to [System Settings] and select [Device/PLC].

The screenshot shows the 'Device/PLC 1' configuration window. It is divided into several sections:

- Summary:** Manufacturer: Azbil Corporation, Series: Controller(CPL), Port: COM1. Text Data Mode: 1. A 'Change Device/PLC' link is visible.
- Communication Settings:**
 - SI0 Type: RS232C, RS422/485(2wire), RS422/485(4wire)
 - Speed: 9600
 - Data Length: 7, 8
 - Parity: NONE, EVEN, ODD
 - Stop Bit: 1, 2
 - Flow Control: NONE, ER(DTR/CTS), XON/XOFF
 - Timeout: 3 (sec)
 - Retry: 2
 - Wait To Send: 10 (ms)
- RI / VCC:** RI, VCC. A note states: 'In the case of RS232C, you can select the 9th pin to RI (Input) or VCC (5V Power Supply). If you use the Digital's RS232C Isolation Unit, please select it to VCC.' A 'Default' button is present.
- Device-Specific Settings:** Allowable Number of Devices/PLCs: 31. An 'Add Device' link is available.
- Device List:** A table with columns 'No.', 'Device Name', and 'Settings'. It contains one entry: No. 1, Device Name PLC1, Settings Series=DCP551, Device Address=1, Sub Address=0. An 'Add Indirect Device' button is on the right.

◆ Device Setting

To display the [Individual Device Settings] dialog box, from [Device-Specific Settings] in the [Device/PLC] window, select the external device and click [Settings] .

To connect multiple External Devices, from [Device-Specific Settings] in the [Device/PLC] window, click [Add Device] to add another External Device.

The screenshot shows the 'Individual Device Settings' dialog box for PLC1. It contains the following fields and controls:

- Series: DCP551 (dropdown menu)
- Text: Please reconfirm all of address settings that you are using if you have changed the series.
- Device Address: 1 (spin box)
- Sub Address: 0 (spin box)
- Buttons: Default, OK (O), Cancel

■ Settings of External Device

To configure communication settings for the External Device, use the PROG, RUN/HOLD, SETUP, ENT, DISP, Down and Up keys on the front of the Controller. You can change the communication settings only in READY mode. Switch the External Device to READY mode before setting.

Refer to your Controller manual for details.

◆ Procedure

- 1 Press the RUN/HOLD key while holding down the PROG key to move to READY mode.
- 2 In the basic display, press the SETUP key to move to the setup group.
- 3 Press the Down/Up keys several times to select a setup item and press the ENT key.
- 4 Use the Down/Up keys to select a setting and press the ENT key.
- 5 Press the DISP key to move to the basic display.

◆ Settings

Setup Items	Settings
C76	1
C77	0
C78	0
C79	0
C80	0
C97	0

NOTE

- The parameters to be set vary depending on the Controller. Refer to your Controller manual for details.

3.26 Setting Example 26

■ Setting of GP-Pro EX

◆ Communication Settings

To display the setup screen, from the [Project] menu, point to [System Settings] and select [Device/PLC].

The screenshot shows the 'Device/PLC 1' configuration window. It has a 'Summary' section with fields for 'Manufacturer' (Azbil Corporation), 'Series' (Controller(CPL)), and 'Port' (COM1). Below this is the 'Communication Settings' section with various options:

- SI0 Type: RS232C, RS422/485(2wire), RS422/485(4wire)
- Speed: 9600
- Data Length: 7, 8
- Parity: NONE, EVEN, ODD
- Stop Bit: 1, 2
- Flow Control: NONE, ER(DTR/CTS), XON/XOFF
- Timeout: 3 (sec)
- Retry: 2
- Wait To Send: 10 (ms)

 There is also a section for 'RI / VCC' with radio buttons for 'RI' (selected) and 'VCC'. A note explains that for RS232C, the 9th pin can be selected to RI (Input) or VCC (5V Power Supply). A 'Default' button is present. At the bottom, 'Device-Specific Settings' shows 'Allowable Number of Devices/PLCs' as 31 and a table with one entry:

No.	Device Name	Settings
1	PLC1	Series=DCP552,Device Address=1,Sub Address=0

 There are 'Add Device' and 'Add Indirect Device' buttons.

◆ Device Setting

To display the [Individual Device Settings] dialog box, from [Device-Specific Settings] in the [Device/PLC] window, select the external device and click [Settings] .

To connect multiple External Devices, from [Device-Specific Settings] in the [Device/PLC] window, click [Add Device] to add another External Device.

The screenshot shows the 'Individual Device Settings' dialog box for 'PLC1'. It contains the following fields:

- Series: DCP552
- Device Address: 1
- Sub Address: 0

 There is a note: 'Please reconfirm all of address settings that you are using if you have changed the series.' At the bottom, there are 'Default', 'OK (O)', and 'Cancel' buttons.

■ Settings of External Device

To configure communication settings for the External Device, use the PROG, RUN/HOLD, SETUP, ENT, DISP, Down and Up keys on the front of the Controller. You can change the communication settings only in READY mode. Switch the External Device to READY mode before setting.

Refer to your Controller manual for details.

◆ Procedure

- 1 Press the RUN/HOLD key while holding down the PROG key to move to READY mode.
- 2 In the basic display, press the SETUP key to move to the setup group.
- 3 Press the Down/Up keys several times to select a setup item and press the ENT key.
- 4 Use the Down/Up keys to select a setting and press the ENT key.
- 5 Press the DISP key to move to the basic display.

◆ Settings

Setup Items	Settings
C76	1
C77	0
C78	0
C79	0
C80	1
C97	0

NOTE

- The parameters to be set vary depending on the Controller. Refer to your Controller manual for details.

3.27 Setting Example 27

■ Setting of GP-Pro EX

◆ Communication Settings

To display the setup screen, from the [Project] menu, point to [System Settings] and select [Device/PLC].

The screenshot shows the 'Device/PLC 1' configuration window. It is divided into several sections:

- Summary:** Manufacturer: Azbil Corporation, Series: Controller(CPL), Port: COM1. A 'Change Device/PLC' link is visible.
- Text Data Mode:** Set to 1 with a 'Change' link.
- Communication Settings:**
 - SI0 Type: RS232C, RS422/485(2wire), RS422/485(4wire)
 - Speed: 9600
 - Data Length: 7, 8
 - Parity: NONE, EVEN, ODD
 - Stop Bit: 1, 2
 - Flow Control: NONE, ER(DTR/CTS), XON/XOFF
 - Timeout: 3 (sec)
 - Retry: 2
 - Wait To Send: 10 (ms)
- RI / VCC:** RI, VCC. A note explains that for RS232C, the 9th pin can be selected for RI (Input) or VCC (5V Power Supply). A 'Default' button is present.
- Device-Specific Settings:** Allowable Number of Devices/PLCs: 31. An 'Add Device' link is available.
- Device List:** A table with columns 'No.', 'Device Name', and 'Settings'. It contains one entry: No. 1, Device Name PLC1, Settings Series=DCP552, Device Address=1, Sub Address=0. An 'Add Indirect Device' button is on the right.

◆ Device Setting

To display the [Individual Device Settings] dialog box, from [Device-Specific Settings] in the [Device/PLC] window, select the external device and click [Settings] .

To connect multiple External Devices, from [Device-Specific Settings] in the [Device/PLC] window, click [Add Device] to add another External Device.

The screenshot shows the 'Individual Device Settings' dialog box for PLC1. It contains the following fields and controls:

- Series: DCP552 (dropdown menu)
- Text: Please reconfirm all of address settings that you are using if you have changed the series.
- Device Address: 1 (spin box)
- Sub Address: 0 (spin box)
- Buttons: Default, OK (O), Cancel

■ Settings of External Device

To configure communication settings for the External Device, use the PROG, RUN/HOLD, SETUP, ENT, DISP, Down and Up keys on the front of the Controller. You can change the communication settings only in READY mode. Switch the External Device to READY mode before setting.

Refer to your Controller manual for details.

◆ Procedure

- 1 Press the RUN/HOLD key while holding down the PROG key to move to READY mode.
- 2 In the basic display, press the SETUP key to move to the setup group.
- 3 Press the Down/Up keys several times to select a setup item and press the ENT key.
- 4 Use the Down/Up keys to select a setting and press the ENT key.
- 5 Press the DISP key to move to the basic display.

◆ Settings

Setup Items	Settings
C76	1
C77	0
C78	0
C79	0
C80	0
C97	0

NOTE

- The parameters to be set vary depending on the Controller. Refer to your Controller manual for details.

3.28 Setting Example 28

■ Setting of GP-Pro EX

◆ Communication Settings

To display the setup screen, from the [Project] menu, point to [System Settings] and select [Device/PLC].

The screenshot shows the 'Device/PLC 1' configuration window. It is divided into several sections:

- Summary:** Manufacturer: Azbil Corporation, Series: Controller(CPL), Port: COM1. Text Data Mode: 1. A 'Change Device/PLC' link is visible.
- Communication Settings:**
 - SI0 Type: RS232C, RS422/485(2wire), RS422/485(4wire)
 - Speed: 9600
 - Data Length: 7, 8
 - Parity: NONE, EVEN, ODD
 - Stop Bit: 1, 2
 - Flow Control: NONE, ER(DTR/CTS), XON/XOFF
 - Timeout: 3 (sec)
 - Retry: 2
 - Wait To Send: 10 (ms)
- RI / VCC:** RI, VCC. A note states: 'In the case of RS232C, you can select the 9th pin to RI (Input) or VCC (5V Power Supply). If you use the Digital's RS232C Isolation Unit, please select it to VCC.' A 'Default' button is present.
- Device-Specific Settings:** Allowable Number of Devices/PLCs: 31. An 'Add Device' link is available.
- Device List:** A table with columns 'No.', 'Device Name', and 'Settings'. It contains one entry: No. 1, Device Name PLC1, Settings Series=DCP552, Device Address=1, Sub Address=0. An 'Add Indirect Device' button is on the right.

◆ Device Setting

To display the [Individual Device Settings] dialog box, from [Device-Specific Settings] in the [Device/PLC] window, select the external device and click [Settings] .

To connect multiple External Devices, from [Device-Specific Settings] in the [Device/PLC] window, click [Add Device] to add another External Device.

The screenshot shows the 'Individual Device Settings' dialog box for PLC1. It contains the following fields and controls:

- Series: DCP552
- Warning: Please reconfirm all of address settings that you are using if you have changed the series.
- Device Address: 1
- Sub Address: 0
- Buttons: Default, OK (O), Cancel

■ Settings of External Device

To configure communication settings for the External Device, use the PROG, RUN/HOLD, SETUP, ENT, DISP, Down and Up keys on the front of the Controller. You can change the communication settings only in READY mode. Switch the External Device to READY mode before setting.

Refer to your Controller manual for details.

◆ Procedure

- 1 Press the RUN/HOLD key while holding down the PROG key to move to READY mode.
- 2 In the basic display, press the SETUP key to move to the setup group.
- 3 Press the Down/Up keys several times to select a setup item and press the ENT key.
- 4 Use the Down/Up keys to select a setting and press the ENT key.
- 5 Press the DISP key to move to the basic display.

◆ Settings

Setup Items	Settings
C76	1
C77	0
C78	0
C79	0
C80	0
C97	0

NOTE

- The parameters to be set vary depending on the Controller. Refer to your Controller manual for details.

3.29 Setting Example 29

■ Setting of GP-Pro EX

◆ Communication Settings

To display the setup screen, from the [Project] menu, point to [System Settings] and select [Device/PLC].

The screenshot shows the 'Device/PLC 1' configuration window. It is divided into several sections:

- Summary:** Manufacturer: Azbil Corporation, Series: Controller(CPL), Port: COM1. Text Data Mode: 1.
- Communication Settings:**
 - SI0 Type: RS232C, RS422/485(2wire), RS422/485(4wire)
 - Speed: 9600
 - Data Length: 7, 8
 - Parity: NONE, EVEN, ODD
 - Stop Bit: 1, 2
 - Flow Control: NONE, ER(DTR/CTS), XON/XOFF
 - Timeout: 3 (sec)
 - Retry: 2
 - Wait To Send: 10 (ms)
- RI / VCC:** RI, VCC. A note states: "In the case of RS232C, you can select the 9th pin to RI (Input) or VCC (5V Power Supply). If you use the Digital's RS232C Isolation Unit, please select it to VCC." A 'Default' button is present.
- Device-Specific Settings:** Allowable Number of Devices/PLCs: 31. A table lists the device:

No.	Device Name	Settings
1	PLC1	Series=SDC45/46, Device Address=1, Sub Address=0

◆ Device Setting

To display the [Individual Device Settings] dialog box, from [Device-Specific Settings] in the [Device/PLC] window, select the external device and click [Settings] .

To connect multiple External Devices, from [Device-Specific Settings] in the [Device/PLC] window, click [Add Device] to add another External Device.

The 'Individual Device Settings' dialog box for PLC1 shows the following configuration:

- Series: SDC45/46
- Device Address: 1
- Sub Address: 0
- Buttons: Default, OK (O), Cancel

A note in the dialog reads: "Please reconfirm all of address settings that you are using if you have changed the series."

■ Settings of External Device

To configure communication settings for the External Device, use the para, enter, display, and cursor keys on the front of the Controller.

Refer to your Controller manual for details.

◆ Procedure

- 1 In the operation display, press and hold the para key (for 2 seconds) to move to PARA bank mode.
- 2 Press the para key to display RS-485 communication bank mode (rS485).
- 3 Press the enter key to move to RS-485 communication bank mode.
- 4 Press the para key to select a setup item and press the enter key.
- 5 Use the cursor keys to select a setting and press the enter key.
- 6 Press the display key to move to the operation display.
- 7 Reboot the External Device.

◆ Settings

Setup Items	Settings
Com.02	1
Com.03	2
Com.04	1
Com.05	0
Com.06	0
Com.07	3

NOTE

- The parameters to be set vary depending on the Controller. Refer to your Controller manual for details.

3.30 Setting Example 30

■ Setting of GP-Pro EX

◆ Communication Settings

To display the setup screen, from the [Project] menu, point to [System Settings] and select [Device/PLC].

The screenshot shows the 'Device/PLC 1' configuration window. It is divided into several sections:

- Summary:** Manufacturer: Azbil Corporation, Series: Controller(CPL), Port: COM1. Text Data Mode: 1. A 'Change Device/PLC' link is visible.
- Communication Settings:**
 - SI0 Type: RS232C, RS422/485(2wire), RS422/485(4wire)
 - Speed: 9600
 - Data Length: 7, 8
 - Parity: NONE, EVEN, ODD
 - Stop Bit: 1, 2
 - Flow Control: NONE, ER(DTR/CTS), XON/XOFF
 - Timeout: 3 (sec)
 - Retry: 2
 - Wait To Send: 10 (ms)
- RI / VCC:** RI, VCC. A note states: 'In the case of RS232C, you can select the 9th pin to RI (Input) or VCC (5V Power Supply). If you use the Digital's RS232C Isolation Unit, please select it to VCC.' A 'Default' button is present.
- Device-Specific Settings:** Allowable Number of Devices/PLCs: 31. An 'Add Device' link is available.
- Device List:** A table with columns 'No.', 'Device Name', and 'Settings'. The first entry is '1', 'PLC1', and 'Series=DMC50,Device Address=1,Sub Address=0'. An 'Add Indirect Device' button is on the right.

◆ Device Setting

To display the [Individual Device Settings] dialog box, from [Device-Specific Settings] in the [Device/PLC] window, select the external device and click [Settings] .

To connect multiple External Devices, from [Device-Specific Settings] in the [Device/PLC] window, click [Add Device] to add another External Device.

The screenshot shows the 'Individual Device Settings' dialog box for 'PLC1'. It contains the following fields and controls:

- Series: DMC50
- Text: 'Please reconfirm all of address settings that you are using if you have changed the series.'
- Device Address: 1
- Sub Address: 0
- Buttons: Default, OK (O), Cancel

■ Settings of External Device

Use the ladder software (Smart Loader Package SLP-D510 V2.2.3) to configure communication settings for the External Device. Use the rotary switch on the front of the Controller to set the device address of the External Device.

Refer to your Controller manual for details.

◆ Procedure

- 1 Set the device address using the device address setting rotary switch on the front of the Controller, as shown below.

After setting the address, reboot the External Device.

Rotary Switch	Settings
ADR	1

- 2 Start up the ladder software.
- 3 Select [New Project] from the [Project] menu.
- 4 In the [Project Group] dialog box, click [OK] to display the [Project Definition] dialog box.
- 5 Type a project name in [Project Name].
- 6 Select the module you want to use from [Module Type], and then click [OK].
- 7 Select [System Parameters] - [Communication Setup] - [Instance] in the tree view.
- 8 Set [Trans.Speed (RS-485 port1)] and [Protocol (RS-485 port1)] on the [Instance Body] tab as shown below.

Setup Items	Settings
Trans.Speed (RS-485 port1)	3
Protocol (RS-485 port1)	1

- 9 Right-click the [Instance Body] tab and select [Download] from the menu that appears to download the settings to the External Device.
- 10 Reboot the External Device.

NOTE

- The parameters to be set vary depending on the Controller. Refer to your Controller manual for details.

3.31 Setting Example 31

■ Setting of GP-Pro EX

◆ Communication Settings

To display the setup screen, from the [Project] menu, point to [System Settings] and select [Device/PLC].

The screenshot shows the 'Device/PLC 1' configuration window. It is divided into several sections:

- Summary:** Manufacturer: Azbil Corporation, Series: Controller(CPL), Port: COM1. Text Data Mode: 1. A 'Change Device/PLC' link is visible.
- Communication Settings:**
 - SI0 Type: RS232C, RS422/485(2wire), RS422/485(4wire)
 - Speed: 9600
 - Data Length: 7, 8
 - Parity: NONE, EVEN, ODD
 - Stop Bit: 1, 2
 - Flow Control: NONE, ER(DTR/CTS), XON/XOFF
 - Timeout: 3 (sec)
 - Retry: 2
 - Wait To Send: 10 (ms)
- RI / VCC:** RI, VCC. A note states: 'In the case of RS232C, you can select the 9th pin to RI (Input) or VCC (5V Power Supply). If you use the Digital's RS232C Isolation Unit, please select it to VCC.' A 'Default' button is present.
- Device-Specific Settings:** Allowable Number of Devices/PLCs: 31. An 'Add Device' link is shown.
- Device List:** A table with columns 'No.', 'Device Name', and 'Settings'. The first entry is '1', 'PLC1', and 'Series=DMC50,Device Address=1,Sub Address=0'. An 'Add Indirect Device' button is on the right.

◆ Device Setting

To display the [Individual Device Settings] dialog box, from [Device-Specific Settings] in the [Device/PLC] window, select the external device and click [Settings] .

To connect multiple External Devices, from [Device-Specific Settings] in the [Device/PLC] window, click [Add Device] to add another External Device.

The screenshot shows the 'Individual Device Settings' dialog box for 'PLC1'. It contains the following fields and controls:

- Series: DMC50
- Warning: Please reconfirm all of address settings that you are using if you have changed the series.
- Device Address: 1
- Sub Address: 0
- Buttons: Default, OK (O), Cancel

■ Settings of External Device

Use the ladder software (Smart Loader Package SLP-D510 V2.2.3) to configure communication settings for the External Device. Use the rotary switch on the front of the Controller to set the device address of the External Device.

Refer to your Controller manual for details.

◆ Procedure

- 1 Set the device address using the device address setting rotary switch on the front of the Controller, as shown below.

After setting the address, reboot the External Device.

Rotary Switch	Settings
ADR	1

- 2 Start up the ladder software.
- 3 Select [New Project] from the [Project] menu.
- 4 In the [Project Group] dialog box, click [OK] to display the [Project Definition] dialog box.
- 5 Type a project name in [Project Name].
- 6 Select the module you want to use from [Module Type], and then click [OK].
- 7 Select [System Parameters] - [Communication Setup] - [Instance] in the tree view.
- 8 Set [Trans.Speed (RS-485 port1)] and [Protocol (RS-485 port1)] on the [Instance Body] tab as shown below.

Setup Items	Settings
Trans.Speed (RS-485 port1)	3
Protocol (RS-485 port1)	1

- 9 Right-click the [Instance Body] tab and select [Download] from the menu that appears to download the settings to the External Device.
- 10 Reboot the External Device.

NOTE

- The parameters to be set vary depending on the Controller. Refer to your Controller manual for details.

3.32 Setting Example 32

■ Setting of GP-Pro EX

◆ Communication Settings

To display the setup screen, from the [Project] menu, point to [System Settings] and select [Device/PLC].

The screenshot shows the 'Device/PLC 1' configuration window. It is divided into several sections:

- Summary:** Manufacturer: Azbil Corporation, Series: Controller(CPL), Port: COM1. Text Data Mode: 1. A 'Change Device/PLC' link is visible.
- Communication Settings:**
 - SI0 Type: RS232C, RS422/485(2wire), RS422/485(4wire)
 - Speed: 9600
 - Data Length: 7, 8
 - Parity: NONE, EVEN, ODD
 - Stop Bit: 1, 2
 - Flow Control: NONE, ER(DTR/CTS), XON/XOFF
 - Timeout: 3 (sec)
 - Retry: 2
 - Wait To Send: 10 (ms)
- RI / VCC:** RI, VCC. A note states: 'In the case of RS232C, you can select the 9th pin to RI (Input) or VCC (5V Power Supply). If you use the Digital's RS232C Isolation Unit, please select it to VCC.' A 'Default' button is present.
- Device-Specific Settings:** Allowable Number of Devices/PLCs: 31. An 'Add Device' link is available.
- Device List:** A table with columns 'No.', 'Device Name', and 'Settings'. It contains one entry: No. 1, Device Name PLC1, Settings Series=CMC10B, Device Address=1, Sub Address=0. An 'Add Indirect Device' button is on the right.

◆ Device Setting

To display the [Individual Device Settings] dialog box, from [Device-Specific Settings] in the [Device/PLC] window, select the external device and click [Settings] .

To connect multiple External Devices, from [Device-Specific Settings] in the [Device/PLC] window, click [Add Device] to add another External Device.

The screenshot shows the 'Individual Device Settings' dialog box for 'PLC1'. It contains the following fields and controls:

- Series: CMC10B
- Text: Please reconfirm all of address settings that you are using if you have changed the series.
- Device Address: 1
- Sub Address: 0
- Buttons: Default, OK (O), Cancel

■ Settings of External Device

Use the ladder software (Smart Loader Package SLP-CM1 V2.0.1) to configure communication settings for the External Device. Use the rotary switch on the front of the Controller to set the device address and transmission speed of the External Device.

Refer to your Controller manual for details.

◆ Procedure

- 1 Set the device address and transmission speed using the rotary switch on the front of the Controller, as shown below.

After setting them, reboot the External Device.

Rotary Switch	Settings
CMC ADDRESS (x10)	0
CMC ADDRESS (x1)	1
HOST ←→ CMC BRATE	2

- 2 Start the ladder software and select [Setup].
- 3 Select [Communication] - [Host] in the tree view and set [Data format] as shown below.

Setup Items	Settings
Data format	0

- 4 Select [Write (SLP10 to CMC10B)] from the [Communication] menu, and download the set data to the External Device.
- 5 Reboot the External Device.

NOTE

- The parameters to be set vary depending on the Controller. Refer to your Controller manual for details.

3.33 Setting Example 33

■ Setting of GP-Pro EX

◆ Communication Settings

To display the setup screen, from the [Project] menu, point to [System Settings] and select [Device/PLC].

The screenshot shows the 'Device/PLC 1' configuration window. It is divided into several sections:

- Summary:** Manufacturer: Azbil Corporation, Series: Controller(CPL), Port: COM1. Text Data Mode: 1. A 'Change Device/PLC' link is visible.
- Communication Settings:**
 - SIQ Type: RS232C, RS422/485(2wire), RS422/485(4wire)
 - Speed: 9600
 - Data Length: 7, 8
 - Parity: NONE, EVEN, ODD
 - Stop Bit: 1, 2
 - Flow Control: NONE, ER(DTR/CTS), XON/XOFF
 - Timeout: 3 (sec)
 - Retry: 2
 - Wait To Send: 10 (ms)
- RI / VCC:** RI, VCC. A note states: 'In the case of RS232C, you can select the 9th pin to RI (Input) or VCC (5V Power Supply). If you use the Digital's RS232C Isolation Unit, please select it to VCC.' A 'Default' button is present.
- Device-Specific Settings:** Allowable Number of Devices/PLCs: 31. An 'Add Device' link is shown.
- Device List:** A table with columns 'No.', 'Device Name', and 'Settings'. The first entry is '1', 'PLC1', and 'Series=PBC,Device Address=1,Sub Address=0'. An 'Add Indirect Device' button is on the right.

◆ Device Setting

To display the [Individual Device Settings] dialog box, from [Device-Specific Settings] in the [Device/PLC] window, select the external device and click [Settings] .

To connect multiple External Devices, from [Device-Specific Settings] in the [Device/PLC] window, click [Add Device] to add another External Device.

The 'Individual Device Settings' dialog box is shown for device 'PLC1'. It contains the following fields and controls:

- Series: PBC (dropdown menu)
- Text: 'Please reconfirm all of address settings that you are using if you have changed the series.'
- Device Address: 1 (spin box)
- Sub Address: 0 (spin box)
- Buttons: Default, OK (O), Cancel

■ Settings of External Device

To configure communication settings for the External Device, use the PARA, RUN, UP/DOWN, and ENT keys on the External Device.

Refer to your Controller manual for details.

◆ Procedure

- 1 Press the PARA key in the RUN mode. Move to the Function number selection.
- 2 Press the UP key and DOWN key, and display the laser beam alignment and intensity alignment[Function 1] or store to EEPROM[Function y].
- 3 Press the ENT key, and move to the alignment mode.
- 4 Press the UP key and DOWN key, and display the function number to set.
- 5 Press the ENT key.
- 6 Use the UP key and DOWN key to select a setting and press the ENT key.
- 7 Press the RUN key to move to the RUN mode.

◆ Settings

Function Number	Settings	Setup Description
P	00	CPL
r	0	9600bps
U	0	Even parity, 1 stop bit

NOTE

- The data length is fixed to 8 bits.

3.34 Setting Example 34

■ Setting of GP-Pro EX

◆ Communication Settings

To display the setup screen, from the [Project] menu, point to [System Settings] and select [Device/PLC].

The screenshot shows the 'Device/PLC 1' configuration window. It is divided into several sections:

- Summary:** Manufacturer: Azbil Corporation, Series: Controller(CPL), Port: COM1. Text Data Mode: 1. A 'Change Device/PLC' link is visible.
- Communication Settings:**
 - SI0 Type: RS232C, RS422/485(2wire), RS422/485(4wire)
 - Speed: 9600
 - Data Length: 7, 8
 - Parity: NONE, EVEN, ODD
 - Stop Bit: 1, 2
 - Flow Control: NONE, ER(DTR/CTS), XON/XOFF
 - Timeout: 3 (sec)
 - Retry: 2
 - Wait To Send: 10 (ms)
- RI / VCC:** RI, VCC. A note states: 'In the case of RS232C, you can select the 9th pin to RI (Input) or VCC (5V Power Supply). If you use the Digital's RS232C Isolation Unit, please select it to VCC.' A 'Default' button is present.
- Device-Specific Settings:** Allowable Number of Devices/PLCs: 31. An 'Add Device' link is available.
- Device List:** A table with columns 'No.', 'Device Name', and 'Settings'. It contains one entry: No. 1, Device Name PLC1, Settings Series=PBC, Device Address=1, Sub Address=0. An 'Add Indirect Device' button is on the right.

◆ Device Setting

To display the [Individual Device Settings] dialog box, from [Device-Specific Settings] in the [Device/PLC] window, select the external device and click [Settings] .

To connect multiple External Devices, from [Device-Specific Settings] in the [Device/PLC] window, click [Add Device] to add another External Device.

The 'Individual Device Settings' dialog box is shown for device PLC1. It contains the following fields and controls:

- Series: PBC (dropdown menu)
- Warning: Please reconfirm all of address settings that you are using if you have changed the series.
- Device Address: 1 (spin box)
- Sub Address: 0 (spin box)
- Buttons: Default, OK (O), Cancel

■ Settings of External Device

To configure communication settings for the External Device, use the PARA, RUN, UP/DOWN, and ENT keys on the External Device.

Refer to your Controller manual for details.

◆ Procedure

- 1 Press the PARA key in the RUN mode. Move to the Function number selection.
- 2 Press the UP key and DOWN key, and display the laser beam alignment and intensity alignment[Function 1] or store to EEPROM[Function y].
- 3 Press the ENT key, and move to the alignment mode.
- 4 Press the UP key and DOWN key, and display the function number to set.
- 5 Press the ENT key.
- 6 Use the UP key and DOWN key to select a setting and press the ENT key.
- 7 Press the RUN key to move to the RUN mode.

◆ Settings

Function Number	Settings	Setup Description
P	00	CPL
r	0	9600bps
U	0	Even parity, 1 stop bit

NOTE

- The data length is fixed to 8 bits.

3.35 Setting Example 35

■ Setting of GP-Pro EX

◆ Communication Settings

To display the setup screen, from the [Project] menu, point to [System Settings] and select [Device/PLC].

The screenshot shows the 'Device/PLC 1' configuration window. It is divided into several sections:

- Summary:** Manufacturer: Azbil Corporation, Series: Controller(CPL), Port: COM1. Text Data Mode: 1. A 'Change Device/PLC' link is visible.
- Communication Settings:**
 - SI0 Type: RS232C, RS422/485(2wire), RS422/485(4wire)
 - Speed: 9600
 - Data Length: 7, 8
 - Parity: NONE, EVEN, ODD
 - Stop Bit: 1, 2
 - Flow Control: NONE, ER(DTR/CTS), XON/XOFF
 - Timeout: 3 (sec)
 - Retry: 2
 - Wait To Send: 50 (ms)
- RI / VCC:** RI, VCC. A note states: 'In the case of RS232C, you can select the 9th pin to RI (Input) or VCC (5V Power Supply). If you use the Digital's RS232C Isolation Unit, please select it to VCC.' A 'Default' button is present.
- Device-Specific Settings:** Allowable Number of Devices/PLCs: 31. An 'Add Device' link is available.
- Device List:** A table with columns 'No.', 'Device Name', and 'Settings'. It contains one entry: No. 1, Device Name PLC1, Settings Series=CMS/CMF015, Device Address=1, Sub Address. An 'Add Indirect Device' button is on the right.

◆ Device Setting

To display the [Individual Device Settings] dialog box, from [Device-Specific Settings] in the [Device/PLC] window, select the external device and click [Settings] .

To connect multiple External Devices, from [Device-Specific Settings] in the [Device/PLC] window, click [Add Device] to add another External Device.

The 'Individual Device Settings' dialog box for PLC1 shows the following configuration:

- Series: CMS/CMF015
- Device Address: 1
- Sub Address: 0
- Buttons: Default, OK (O), Cancel

A note in the dialog reads: 'Please reconfirm all of address settings that you are using if you have changed the series.'

■ Settings of External Device

To configure communication settings for the External Device, use the DISP, MODE, UP/DOWN, and ENT keys on the External Device.

Refer to your Controller manual for details.

◆ Procedure

- 1 Press the MODE key in the Normal mode display. Move to the Function setup mode.
- 2 Press UP key and DOWN key, and display the setting mode number.
- 3 Press the ENT key.
- 4 Use the UP key and DOWN key to select a setting, and press the ENT key.
- 5 Press the DISP key to move to the Normal mode display.

◆ Settings

Mode	Settings	Setup Description
30	1	Station address
31	0	9600bps
32	0	8 bits data, even parity, 1 stop bit

3.36 Setting Example 36

■ Setting of GP-Pro EX

◆ Communication Settings

To display the setup screen, from the [Project] menu, point to [System Settings] and select [Device/PLC].

The screenshot shows the 'Device/PLC 1' configuration window. It is divided into several sections:

- Summary:** Manufacturer: Azbil Corporation, Series: Controller(CPL), Port: COM1. Text Data Mode: 1. A 'Change Device/PLC' link is visible.
- Communication Settings:**
 - SI0 Type: RS232C, RS422/485(2wire), RS422/485(4wire)
 - Speed: 9600
 - Data Length: 7, 8
 - Parity: NONE, EVEN, ODD
 - Stop Bit: 1, 2
 - Flow Control: NONE, ER(DTR/CTS), XON/XOFF
 - Timeout: 3 (sec)
 - Retry: 2
 - Wait To Send: 100 (ms)
- RI / VCC:** RI, VCC. A note states: 'In the case of RS232C, you can select the 9th pin to RI (Input) or VCC (5V Power Supply). If you use the Digital's RS232C Isolation Unit, please select it to VCC.' A 'Default' button is present.
- Device-Specific Settings:** Allowable Number of Devices/PLCs: 31. An 'Add Device' link is available.
- Device List:** A table with columns 'No.', 'Device Name', and 'Settings'. It contains one entry: No. 1, Device Name 'PLC1', Settings 'Series=CML/CMF050, Device Address=1, Sub Address'. An 'Add Indirect Device' button is on the right.

◆ Device Setting

To display the [Individual Device Settings] dialog box, from [Device-Specific Settings] in the [Device/PLC] window, select the external device and click [Settings] .

To connect multiple External Devices, from [Device-Specific Settings] in the [Device/PLC] window, click [Add Device] to add another External Device.

The 'Individual Device Settings' dialog box for 'PLC1' is shown. It contains the following fields and controls:

- Series: CML/CMF050 (dropdown menu)
- Text: 'Please reconfirm all of address settings that you are using if you have changed the series.'
- Device Address: 1 (spin box)
- Sub Address: 0 (spin box)
- Buttons: Default, OK (O), Cancel

■ Settings of External Device

To configure communication settings for the External Device, use the MODE, UP/DOWN, and ENT keys on the External Device.

Refer to your Controller manual for details.

◆ Procedure

- 1 Press for more than 3 seconds at the same time the MODE key and UP key in the Normal mode display. Move to the Function setup mode.
- 2 Press UP key and DOWN key, and display the mode number to set.
- 3 Press the ENT key.
- 4 Use the UP key and DOWN key to select a setting, and press the ENT key.
- 5 Press the MODE key to move to the Normal mode display.

◆ Settings

Mode	Settings	Setup Description
5-30	01h	Station address
5-31	00	9600bps
5-32	01	8-bit data, no parity, 2 stop bits

3.37 Setting Example 37

■ Setting of GP-Pro EX

◆ Communication Settings

To display the setup screen, from the [Project] menu, point to [System Settings] and select [Device/PLC].

◆ Device Setting

To display the [Individual Device Settings] dialog box, from [Device-Specific Settings] in the [Device/PLC] window, select the external device and click [Settings] .

To connect multiple External Devices, from [Device-Specific Settings] in the [Device/PLC] window, click [Add Device] to add another External Device.

■ Settings of External Device

To configure communication settings for the External Device, use the MODE, UP/DOWN, and ENT keys on the External Device.

Refer to your Controller manual for details.

◆ Procedure

- 1 Press for more than 3 seconds at the same time the MODE key and UP key in the Normal mode display. Move to the Function setup mode.
- 2 Press UP key and DOWN key, and display the mode number to set.
- 3 Press the ENT key.
- 4 Use the UP key and DOWN key to select a setting, and press the ENT key.
- 5 Press the MODE key to move to the Normal mode display.

◆ Settings

Mode	Settings	Setup Description
5-30	01h	Station address
5-31	00	9600bps
5-32	01	8-bit data, no parity, 2 stop bits

3.38 Setting Example 38

■ Setting of GP-Pro EX

◆ Communication Settings

To display the setup screen, from the [Project] menu, point to [System Settings] and select [Device/PLC].

Device/PLC 1

Summary [Change Device/PLC](#)

Manufacturer Series Port

Text Data Mode [Change](#)

Communication Settings

SID Type RS232C RS422/485(2wire) RS422/485(4wire)

Speed

Data Length 7 8

Parity NONE EVEN ODD

Stop Bit 1 2

Flow Control NONE ER(DTR/CTS) XON/XOFF

Timeout (sec)

Retry

Wait To Send (ms)

RI / VCC RI VCC

In the case of RS232C, you can select the 9th pin to RI (Input) or VCC (5V Power Supply). If you use the Digital's RS232C Isolation Unit, please select it to VCC.

[Default](#)

Device-Specific Settings

Allowable Number of Devices/PLCs 31 [Add Device](#)

No.	Device Name	Settings
1	PLC1	Series=CMQV, Device Address=1, Sub Address=0

[Add Indirect Device](#)

◆ Device Setting

To display the [Individual Device Settings] dialog box, from [Device-Specific Settings] in the [Device/PLC] window, select the external device and click [Settings] .

To connect multiple External Devices, from [Device-Specific Settings] in the [Device/PLC] window, click [Add Device] to add another External Device.

Individual Device Settings

PLC1

Series

Please reconfirm all of address settings that you are using if you have changed the series.

Device Address

Sub Address

[Default](#)

[OK \(O\)](#) [Cancel](#)

■ Settings of External Device

To configure communication settings for the External Device, use the DISP, UP/DOWN, and ENT keys on the External Device.

Refer to your Controller manual for details.

◆ Procedure

- 1 Press for more than 3 seconds at the same time the DOWN key and ENT key in the Normal mode display. Move to the Function setup mode.
- 2 Press UP key and DOWN key, and display the Setup item number.
- 3 Press the ENT key.
- 4 Use the UP key and DOWN key to select a setting, and press the ENT key.
- 5 Press the DISP key to move to the Normal mode display.

◆ Settings

Function setup item	Settings	Setup Description
C-30	1	Station address
C-31	1	19200bps
C-32	0	8 bits data, even parity, 1 stop bit

3.39 Setting Example 39

■ Setting of GP-Pro EX

◆ Communication Settings

To display the setup screen, from the [Project] menu, point to [System Settings] and select [Device/PLC].

The screenshot shows the 'Device/PLC 1' configuration window. It is divided into several sections:

- Summary:** Manufacturer: Azbil Corporation, Series: Controller(CPL), Port: COM1. Text Data Mode: 1. A 'Change Device/PLC' link is visible.
- Communication Settings:**
 - SI0 Type: RS232C, RS422/485(2wire), RS422/485(4wire)
 - Speed: 19200
 - Data Length: 7, 8
 - Parity: NONE, EVEN, ODD
 - Stop Bit: 1, 2
 - Flow Control: NONE, ER(DTR/CTS), XON/XOFF
 - Timeout: 3 (sec)
 - Retry: 2
 - Wait To Send: 10 (ms)
- RI / VCC:** RI, VCC. A note states: 'In the case of RS232C, you can select the 9th pin to RI (Input) or VCC (5V Power Supply). If you use the Digital's RS232C Isolation Unit, please select it to VCC.' A 'Default' button is present.
- Device-Specific Settings:** Allowable Number of Devices/PLCs: 31. An 'Add Device' link is shown.
- Device List:** A table with columns 'No.', 'Device Name', and 'Settings'. It contains one entry: No. 1, Device Name PLC1, Settings Series=MPC, Device Address=1, Sub Address=0. An 'Add Indirect Device' button is on the right.

◆ Device Setting

To display the [Individual Device Settings] dialog box, from [Device-Specific Settings] in the [Device/PLC] window, select the external device and click [Settings] .

To connect multiple External Devices, from [Device-Specific Settings] in the [Device/PLC] window, click [Add Device] to add another External Device.

The screenshot shows the 'Individual Device Settings' dialog box for 'PLC1'. It contains the following fields and controls:

- Series: MPC (dropdown menu)
- Text: Please reconfirm all of address settings that you are using if you have changed the series.
- Device Address: 1 (spin box)
- Sub Address: 0 (spin box)
- Buttons: Default, OK (O), Cancel

■ Settings of External Device

To configure communication settings for the External Device, use the DISP, UP/DOWN, <, and ENT keys on the External Device.

Refer to your Controller manual for details.

◆ Procedure

- 1 Press the DISP key, and display the integrated display mode.
- 2 Press for more than 3 seconds the < key. Move to the parameter settings mode.
- 3 Press for more than 3 seconds the < key again. Move to the function setting mode.
- 4 Press UP key and DOWN key, and display a target setting item number.
- 5 Press the ENT key.
- 6 Use the UP key and DOWN key to select a setting, and press the ENT key.
- 7 Press the DISP key to move to the Normal mode display.

◆ Settings

Display	Settings	Setup Description
C-30	1	Station address
C-31	1	19200bps
C-32	0	8 bits data, even parity, 1 stop bit

3.40 Setting Example 40

■ Setting of GP-Pro EX

◆ Communication Settings

To display the setup screen, from the [Project] menu, point to [System Settings] and select [Device/PLC].

The screenshot shows the 'Device/PLC 1' configuration window. It is divided into several sections:

- Summary:** Manufacturer: Azbil Corporation, Series: Controller(CPL), Port: COM1. Text Data Mode: 1. A 'Change Device/PLC' link is visible.
- Communication Settings:**
 - SI0 Type: RS232C, RS422/485(2wire), RS422/485(4wire)
 - Speed: 19200
 - Data Length: 7, 8
 - Parity: NONE, EVEN, ODD
 - Stop Bit: 1, 2
 - Flow Control: NONE, ER(DTR/CTS), XON/XOFF
 - Timeout: 3 (sec)
 - Retry: 2
 - Wait To Send: 10 (ms)
- RI / VCC:** RI, VCC. A note states: 'In the case of RS232C, you can select the 9th pin to RI (Input) or VCC (5V Power Supply). If you use the Digital's RS232C Isolation Unit, please select it to VCC.' A 'Default' button is present.
- Device-Specific Settings:** Allowable Number of Devices/PLCs: 31. An 'Add Device' link is available.
- Device List:** A table with columns 'No.', 'Device Name', and 'Settings'. It contains one entry: No. 1, Device Name PLC1, Settings Series=MVF, Device Address=1, Sub Address=0. An 'Add Indirect Device' button is on the right.

◆ Device Setting

To display the [Individual Device Settings] dialog box, from [Device-Specific Settings] in the [Device/PLC] window, select the external device and click [Settings] .

To connect multiple External Devices, from [Device-Specific Settings] in the [Device/PLC] window, click [Add Device] to add another External Device.

The screenshot shows the 'Individual Device Settings' dialog box for 'PLC1'. It contains the following fields and controls:

- Series: MVF (dropdown menu)
- Text: Please reconfirm all of address settings that you are using if you have changed the series.
- Device Address: 1 (spin box)
- Sub Address: 0 (spin box)
- Buttons: Default, OK (O), Cancel

■ Settings of External Device

To configure communication settings for the External Device, use the Communications parameters switch and Station address setting switch on the External Device.

Refer to your Controller manual for details.

- Communications parameters switch

DIP Switch	Settings	Setup Description
1	ON	Setting effective
2	OFF	19200bps
3	OFF	
4	OFF	8-bit data, 1 stop bit, even parity

- Station address setting switch

	Settings	Setup Description
Rotary switch	1h	Station address

3.41 Setting Example 41

■ Setting of GP-Pro EX

◆ Communication Settings

To display the setup screen, from the [Project] menu, point to [System Settings] and select [Device/PLC].

The screenshot shows the 'Device/PLC 1' configuration window. It is divided into several sections:

- Summary:** Manufacturer: Azbil Corporation, Series: Controller(CPL), Port: COM1. Text Data Mode: 1. A 'Change Device/PLC' link is visible.
- Communication Settings:**
 - SI0 Type: RS232C, RS422/485(2wire), RS422/485(4wire)
 - Speed: 19200
 - Data Length: 7, 8
 - Parity: NONE, EVEN, ODD
 - Stop Bit: 1, 2
 - Flow Control: NONE, ER(DTR/CTS), XON/XOFF
 - Timeout: 3 (sec)
 - Retry: 2
 - Wait To Send: 10 (ms)
- RI / VCC:** RI, VCC. A note states: 'In the case of RS232C, you can select the 9th pin to RI (Input) or VCC (5V Power Supply). If you use the Digital's RS232C Isolation Unit, please select it to VCC.' A 'Default' button is present.
- Device-Specific Settings:** Allowable Number of Devices/PLCs: 31. An 'Add Device' link is available.
- Device List:** A table with columns 'No.', 'Device Name', and 'Settings'. It contains one entry: No. 1, Device Name PLC1, Settings Series=AUR350C, Device Address=1, Sub Address=0. An 'Add Indirect Device' button is on the right.

◆ Device Setting

To display the [Individual Device Settings] dialog box, from [Device-Specific Settings] in the [Device/PLC] window, select the external device and click [Settings] .

To connect multiple External Devices, from [Device-Specific Settings] in the [Device/PLC] window, click [Add Device] to add another External Device.

The screenshot shows the 'Individual Device Settings' dialog box for device PLC1. It contains the following fields and controls:

- Series: AUR350C
- Warning: Please reconfirm all of address settings that you are using if you have changed the series.
- Device Address: 1
- Sub Address: 0
- Buttons: Default, OK (O), Cancel

■ Settings of External Device

To configure communication settings for the External Device, use the ADDRESS switch on the External Device and the setting tool (Smart Loader Package SLP-A35).

Refer to your Controller manual for details.

- ADDRESS switch

Set to "1" using the ADDRESS switch. After setting them, reboot the External Device.

- Setting tool

- 1 Start up the setting tool.
- 2 Select the [Port setup] from [Menu] menu, and select the using Communication port.
- 3 Select the [Set up] from [Menu] menu, and click the [Basic setup] tab.
- 4 Set the [RS-485 communications settings] as follows:

Setup Items	Settings
Data format	0:8 bits, even parity, 1 stop bit
Transmission speed	3:19200bps

- 5 Write the settings into the External Device, and reboot the External Device.

3.42 Setting Example 42

■ Setting of GP-Pro EX

◆ Communication Settings

To display the setup screen, from the [Project] menu, point to [System Settings] and select [Device/PLC].

The screenshot shows the 'Device/PLC 1' configuration window. It is divided into several sections:

- Summary:** Manufacturer: Azbil Corporation, Series: Controller(CPL), Port: COM1. Text Data Mode: 1. A 'Change Device/PLC' link is visible.
- Communication Settings:**
 - SI0 Type: RS232C, RS422/485(2wire), RS422/485(4wire)
 - Speed: 19200
 - Data Length: 7, 8
 - Parity: NONE, EVEN, ODD
 - Stop Bit: 1, 2
 - Flow Control: NONE, ER(DTR/CTS), XON/XOFF
 - Timeout: 3 (sec)
 - Retry: 2
 - Wait To Send: 10 (ms)
- RI / VCC:** RI, VCC. A note states: 'In the case of RS232C, you can select the 9th pin to RI (Input) or VCC (5V Power Supply). If you use the Digital's RS232C Isolation Unit, please select it to VCC.' A 'Default' button is present.
- Device-Specific Settings:** Allowable Number of Devices/PLCs: 31. An 'Add Device' link is available.
- Device List:** A table with columns 'No.', 'Device Name', and 'Settings'. It contains one entry: No. 1, Device Name PLC1, Settings Series=AUR450C, Device Address=1, Sub Address=0. An 'Add Indirect Device' button is on the right.

◆ Device Setting

To display the [Individual Device Settings] dialog box, from [Device-Specific Settings] in the [Device/PLC] window, select the external device and click [Settings] .

To connect multiple External Devices, from [Device-Specific Settings] in the [Device/PLC] window, click [Add Device] to add another External Device.

The screenshot shows the 'Individual Device Settings' dialog box for PLC1. It contains the following fields and controls:

- Series: AUR450C
- Warning: Please reconfirm all of address settings that you are using if you have changed the series.
- Device Address: 1
- Sub Address: 0
- Buttons: Default, OK (O), Cancel

■ Settings of External Device

To configure communication settings for the External Device, use the ADDRESS switch on the External Device and the setting tool (Smart Loader Package SLP-A45).

Refer to your Controller manual for details.

- ADDRESS switch

Set to "1" using the ADDRESS switch. After setting them, reboot the External Device.

- Setting tool

- 1 Start up the setting tool.
- 2 Select the [Port setup] from [Menu] menu, and select the using Communication port.
- 3 Select the [Set up] from [Menu] menu.
- 4 Set the [RS-485 communications settings] as follows:

Setup Items	Settings
Data format	0:8 bits, even parity, 1 stop bit
Transmission speed	19200bps

- 5 Write the settings into the External Device, and reboot the External Device.

3.43 Setting Example 43

■ Setting of GP-Pro EX

◆ Communication Settings

To display the setup screen, from the [Project] menu, point to [System Settings] and select [Device/PLC].

The screenshot shows the 'Device/PLC 1' configuration window. It is divided into several sections:

- Summary:** Manufacturer: Azbil Corporation, Series: Controller(CPL), Port: COM1. Text Data Mode: 1. A 'Change Device/PLC' link is visible.
- Communication Settings:**
 - SI0 Type: RS232C, RS422/485(2wire), RS422/485(4wire)
 - Speed: 19200
 - Data Length: 7, 8
 - Parity: NONE, EVEN, ODD
 - Stop Bit: 1, 2
 - Flow Control: NONE, ER(DTR/CTS), XON/XOFF
 - Timeout: 3 (sec)
 - Retry: 2
 - Wait To Send: 10 (ms)
- RI / VCC:** RI, VCC. A note states: 'In the case of RS232C, you can select the 9th pin to RI (Input) or VCC (5V Power Supply). If you use the Digital's RS232C Isolation Unit, please select it to VCC.' A 'Default' button is present.
- Device-Specific Settings:** Allowable Number of Devices/PLCs: 31. An 'Add Device' link is shown.
- Device List:** A table with columns 'No.', 'Device Name', and 'Settings'. It contains one entry: No. 1, Device Name 'PLC1', Settings 'Series=RX, Device Address=1, Sub Address=0'. An 'Add Indirect Device' button is on the right.

◆ Device Setting

To display the [Individual Device Settings] dialog box, from [Device-Specific Settings] in the [Device/PLC] window, select the external device and click [Settings] .

To connect multiple External Devices, from [Device-Specific Settings] in the [Device/PLC] window, click [Add Device] to add another External Device.

The screenshot shows the 'Individual Device Settings' dialog box for 'PLC1'. It contains the following fields and controls:

- Series: RX (dropdown menu)
- Text: Please reconfirm all of address settings that you are using if you have changed the series.
- Device Address: 1 (spin box)
- Sub Address: 0 (spin box)
- Buttons: Default, OK (O), Cancel

■ Settings of External Device

To configure communication settings for the External Device, use the setting tool (Smart Loader Package SLP-RXE).

Refer to your Controller manual for details.

- 1 Start up the setting tool.
- 2 Select the [COM port settings] from [Port setup] menu, and set the port used to communicate.
- 3 Insert the loader cable into the loader jack of the External Device, and select the [Connect] from [Online] menu.
The current settings of the External Device are displayed.
- 4 Select the [Communication]-[Host communication]-[RS-485] in the tree view.
- 5 Set the following settings.

Code	Settings	Setup Description
F-1	1	Host communication RS-485 Station address
F-2	19200	Host communication RS-485 Baud rate
F-3	Even parity, 1 stop bit	8-bit data, even parity, 1 stop bit
F-4	CPL	Host communication RS-485 Protocol
F-5	Disable	RX-R start by communication enable

- 6 Write the settings into the External Device.

3.44 Setting Example 44

■ Setting of GP-Pro EX

◆ Communication Settings

To display the setup screen, from the [Project] menu, point to [System Settings] and select [Device/PLC].

The screenshot shows the 'Device/PLC 1' configuration window. It has a 'Summary' section with fields for 'Manufacturer' (Azbil Corporation), 'Series' (Controller(CPL)), and 'Port' (COM1). Below this is the 'Communication Settings' section with radio buttons for 'SIO Type' (RS232C, RS422/485(2wire), RS422/485(4wire)), a 'Speed' dropdown (19200), 'Data Length' (7, 8), 'Parity' (NONE, EVEN, ODD), 'Stop Bit' (1, 2), 'Flow Control' (NONE, ER(DTR/CTS), XON/XOFF), and numeric spinners for 'Timeout' (3 sec), 'Retry' (2), and 'Wait To Send' (10 ms). There is also a section for 'RI / VCC' with radio buttons and a 'Default' button. At the bottom, the 'Device-Specific Settings' section shows 'Allowable Number of Devices/PLCs' as 31 and a table with one device: '1 | PLC1 | Series=BC-R, Device Address=1, Sub Address=0'. There are 'Add Device' and 'Add Indirect Device' buttons.

◆ Device Setting

To display the [Individual Device Settings] dialog box, from [Device-Specific Settings] in the [Device/PLC] window, select the external device and click [Settings] .

To connect multiple External Devices, from [Device-Specific Settings] in the [Device/PLC] window, click [Add Device] to add another External Device.

The screenshot shows the 'Individual Device Settings' dialog box for 'PLC1'. It has a 'Series' dropdown menu set to 'BC-R'. Below this is a warning: 'Please reconfirm all of address settings that you are using if you have changed the series.' There are two numeric spinners: 'Device Address' (set to 1) and 'Sub Address' (set to 0). At the bottom, there are 'Default', 'OK (O)', and 'Cancel' buttons.

■ Settings of External Device

To configure communication settings for the External Device, use the DISP and RESET switches on the front of the Controller.

Refer to your Controller manual for details.

◆ Procedure

- 1 Turn the power OFF, and insert the dedicated pin plug into the loader jack connector.
- 2 Turn the power ON while pressing the DISP switch. Once [H-] appears, release the DISP switch.
- 3 Press the DISP switch for more than 5 seconds.
[H1] appears and the unit enters the function selection mode.
- 4 Press the DISP switch, select the setup item, then press the RESET switch.
- 5 Press the DISP switch, define the setting, then press the RESET switch.
- 6 Turn the power OFF, and remove the dedicated pin plug.

◆ Settings

Setup items	Settings	Setup Description
H2	1	Communication address
H3	3: 19200 bps	Baud rate
H4	1: Even parity, Stop bit 1	Communication format

3.45 Setting Example 45

■ Setting of GP-Pro EX

◆ Communication Settings

To display the setup screen, from the [Project] menu, point to [System Settings] and select [Device/PLC].

Device/PLC 1

Summary [Change Device/PLC](#)

Manufacturer Series Port

Text Data Mode [Change](#)

Communication Settings

SIO Type RS232C RS422/485(2wire) RS422/485(4wire)

Speed

Data Length 7 8

Parity NONE EVEN ODD

Stop Bit 1 2

Flow Control NONE ER(DTR/CTS) XON/XOFF

Timeout (sec)

Retry

Wait To Send (ms)

RI / VCC RI VCC

In the case of RS232C, you can select the 9th pin to RI (Input) or VCC (5V Power Supply). If you use the Digital's RS232C Isolation Unit, please select it to VCC.

Device-Specific Settings

Allowable Number of Devices/PLCs 31 [Add Device](#)

No.	Device Name	Settings
1	PLC1	Series=C1M, Device Address=1, Sub Address=0

◆ Device Setting

To display the [Individual Device Settings] dialog box, from [Device-Specific Settings] in the [Device/PLC] window, select the external device and click [Settings] .

To connect multiple External Devices, from [Device-Specific Settings] in the [Device/PLC] window, click [Add Device] to add another External Device.

Individual Device Settings

PLC1

Series

Please reconfirm all of address settings that you are using if you have changed the series.

Device Address

Sub Address

■ Settings of External Device

To configure communication settings for the External Device, use the Operation Panel on the front of the Controller or the ladder software (SLP-C1F v1.4.1).

Refer to your Controller manual for details.

- Operation Panel

- 1 In the operation display, press and hold the PARA key (for 2 seconds) to move to the Bank selection display.
- 2 In the Bank selection display, press and hold the PARA key (for 2 seconds) to move to the Setup bank selection display.
- 3 Press the PARA key several times to display the following setup item.
- 4 Use the Down/Up keys to select a setting.
The set value will blink.
When no operation is performed for 2 seconds, the set value stops blinking and the change is fixed.
- 5 After setting, press and hold the PARA key (for 2 seconds) or press the MODE key to move to the operation display.

- Ladder software

- 1 Connect the loader cable to the loader connector on the External Device.
Use SIO-USB adapter if necessary.
- 2 Start up the ladder software.
- 3 Select [Menu] - [Option(E)].
- 4 Select the communication port to use.
- 5 Select [Standard] - [Setup(Comm)].
- 6 Set the following setup item.
- 7 After setting, click [Write(SLP->C1M)] or [Communication] - [Write(SLP->C1M)].

◆ Settings

Setup items	Display	Initial value	Settings	Setup Description
Communication type	C64	0	0	CPL
Station address	C65	0	1	Set the same value as the Device Address set in the Display's Individual Device Settings.
Transmission speed	C66	2	3	38400 bps
Dara format (data length)	C67	1	1	8 bits
Dara format (parity)	C68	0	0	Even parity
Data format (stop bit)	C69	0	0	1 bit
Communication minimum response time	C70	3	3	3 ms

4 Setup Items

Set the communication settings of the Display with GP-Pro Ex or in offline mode of the Display.

The setting of each parameter must match that of the External Device.

 "3 Example of Communication Setting" (page 13)

4.1 Setup Items in GP-Pro EX

■ Communication Settings

To display the setup screen, from the [Project] menu, point to [System Settings] and select [Device/PLC].

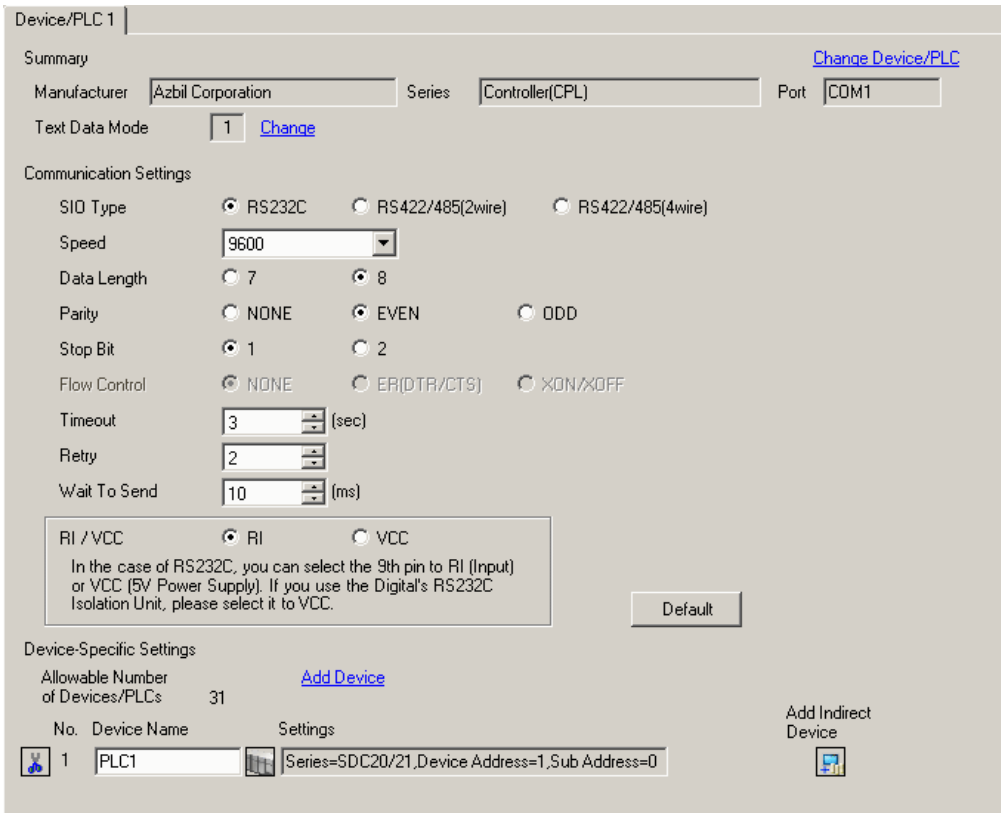

Device/PLC 1

Summary [Change Device/PLC](#)

Manufacturer Series Port

Text Data Mode [Change](#)

Communication Settings

SIO Type RS232C RS422/485(2wire) RS422/485(4wire)

Speed

Data Length 7 8

Parity NONE EVEN ODD

Stop Bit 1 2

Flow Control NONE ER(DTR/CTS) XON/XOFF

Timeout (sec)

Retry

Wait To Send (ms)

RI / VCC RI VCC

In the case of RS232C, you can select the 9th pin to RI (Input) or VCC (5V Power Supply). If you use the Digital's RS232C Isolation Unit, please select it to VCC.

Device-Specific Settings

Allowable Number of Devices/PLCs [Add Device](#)

No.	Device Name	Settings	Add Indirect Device
<input type="button" value="1"/>	<input type="text" value="PLC1"/>	<input type="text" value="Series=SDC20/21,Device Address=1,Sub Address=0"/>	<input type="button" value="Add Indirect Device"/>

Setup Items	Setup Description
SIO Type	Select the SIO type for communicating with the External Device.
Speed	Select the communication speed between the External Device and the Display.
Data Length	Select a data length.
Parity	Select how to check parity.
Stop Bit	Select a stop bit length.
Flow Control	Displays the communication control method to prevent overflow of transmission and reception data.
Timeout	Enter the time (s) for which the Display waits for a response from the External Device, from "1 to 127".

Continued to next page.

Setup Items	Setup Description
Retry	In case of no response from the External Device, enter how many times the Display retransmits the command, from "0 to 255".
Wait To Send	Enter the standby time (ms) from when the Display receives packets until it transmits the next command, from "0 to 255".
RI/VCC	Switches between RI/VCC of the 9th pin. To connect to the IPC, you need to switch between RI/5V using the IPC selector switch. Refer to your IPC manual for details.

NOTE

- Refer to the GP-Pro EX Reference Manual for Indirect Device.

Cf. GP-Pro EX Reference Manual "Changing the Device/PLC at Runtime (Indirect Device)"

■ Device Setting

To display the [Individual Device Settings] dialog box, from [Device-Specific Settings] in the [Device/PLC] window, select the external device and click [Settings] .

To connect multiple External Devices, from [Device-Specific Settings] in the [Device/PLC] window, click [Add Device] to add another External Device.

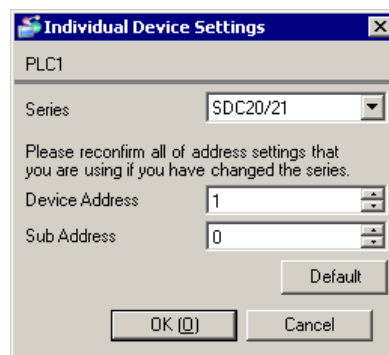

Setup Items	Setup Description
Series	Displays the model of the External Device.
Device Address	Enter the address of the External Device, from "1 to 127".
Sub Address	Enter "0" to communicate with the External Device. If you communicate with the child station (External Device) via the parent station (CMC10B, DMC10, or DMC50), however, enter "1 to 31" for the child station address.

4.2 Settings in Offline Mode

NOTE

- Refer to the Maintenance/Troubleshooting guide for information on how to enter offline mode or about the operation.

Cf. Maintenance/Troubleshooting Guide "Offline Mode"

- The number of the setup items to be displayed for 1 page in the offline mode depends on the Display in use. Please refer to the Reference manual for details.

■ Communication Settings

To display the setting screen, touch [Device/PLC Settings] from [Peripheral Equipment Settings] in offline mode. Touch the External Device you want to set from the list that appears.

Comm.	Device	Option		
Digital Controller SIO		[COM1]	Page 1/1	
SIO Type	RS422/485(2wire)			
Speed	9600			
Data Length	<input type="radio"/> 7 <input checked="" type="radio"/> 8			
Parity	<input type="radio"/> NONE <input checked="" type="radio"/> EVEN <input type="radio"/> ODD			
Stop Bit	<input checked="" type="radio"/> 1 <input type="radio"/> 2			
Flow Control	NONE			
Timeout(s)	3			
Retry	2			
Wait To Send(ms)	10			
Exit		Back		2007/10/20 04:02:40

Setup Items	Setup Description
SIO Type	Select the SIO type for communicating with the External Device. IMPORTANT In the communication settings, set [SIO Type] correctly according to the serial interface specifications of the Display. If you select an SIO type that the serial interface does not support, proper operation cannot be guaranteed. Refer to your Display manual for details on the serial interface specifications.
Speed	Select the communication speed between the External Device and the Display.
Data Length	Select a data length.
Parity	Select how to check parity.
Stop Bit	Select a stop bit length.

Continued to next page.

Setup Items	Setup Description
Flow Control	Displays the communication control method to prevent overflow of transmission and reception data.
Timeout	Enter the time (s) for which the Display waits for a response from the External Device, from "1 to 127".
Retry	In case of no response from the External Device, enter how many times the Display retransmits the command, from "0 to 255".
Wait To Send	Enter the standby time (ms) from when the Display receives packets until it transmits the next command, from "0 to 255".

■ Device Setting

To display the setting screen, touch [Device/PLC Settings] from [Peripheral Equipment Settings]. Touch the External Device you want to set from the list that appears, and touch [Device Settings].

Comm.	Device	Option		
Digital Controller S10		[COM1]	Page 1/1	
Device/PLC Name		PLC1		
Series		SDC25/26		
Device Address		1		
Sub Address		0		
Exit		Back		2007/10/20 04:02:56

Setup Items	Setup Description
Device/PLC Name	Select the External Device to set. Device name is the title of the External Device set with GP-Pro EX. (Initial value [PLC])
Series	Displays the model of the External Device.
Device Address	Enter the address of the External Device, from "1 to 127".
Sub Address	Enter "0" to communicate with the External Device. If you communicate with the child station (External Device) via the parent station (CMC10B, DMC10, or DMC50), however, enter "1 to 31" for the child station address.

■ Option

To display the setting screen, touch [Device/PLC Settings] from [Peripheral Equipment Settings]. Touch the External Device you want to set from the list that appears, and touch [Option].

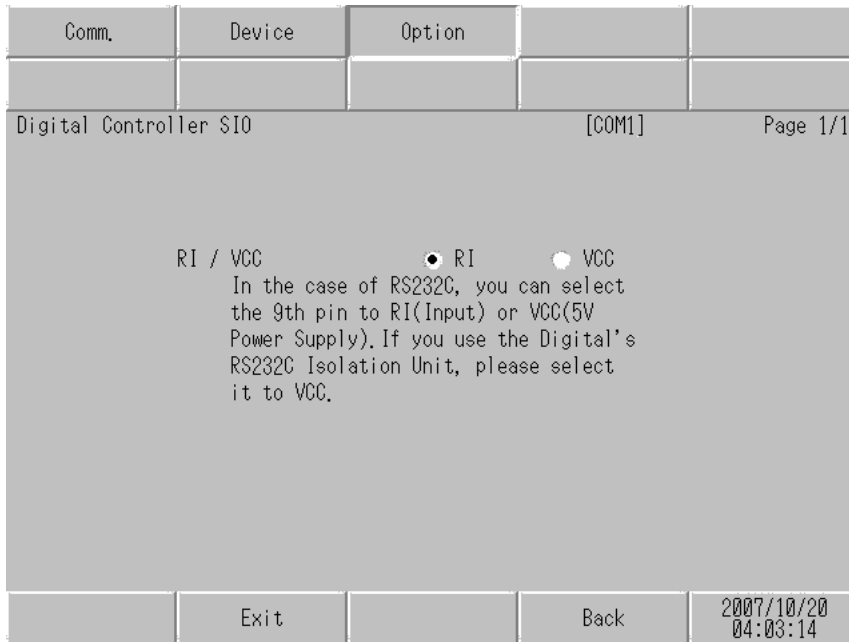

Setup Items	Setup Description
RI/VCC	Switches between RI/VCC of the 9th pin. To connect to the IPC, you need to switch between RI/5V using the IPC selector switch. Refer to your IPC manual for details.

NOTE

- GP-4100 series, GP-4*01TM, GP-Rear Module, LT-4*01TM and LT-Rear Module do not have the [Option] setting in the offline mode.

5 Cable Diagram

The cable diagram shown below may differ from that recommended by Azbil Corporation. Please be assured, however, that there is no operational problem in applying the cable diagram shown in this manual.

- The FG pin on the External Device must be D-class grounded. Refer to your External Device manual for details.
- The SG and FG are connected inside the Display. If you connect the External Device to the SG, do not form any short-circuit loop in the system design.
- Consult your External Device manual for the pin No. on the External Device side. It varies depending on the additional function.
- If the communication is not stable because of noise or other factors, connect an isolation unit.
- Recommended cable

Company Name		Model
Fujikura Densen, Ltd.	Duplex	IPEV-S-0.9mm ² x 1P
	Triplex	ITEV-S-0.9mm ² x 1T
Hitachi Cable, Ltd.	Duplex	KPEV-S-0.9mm ² x 1P
	Triplex	KTEV-S-0.9mm ² x 1T

Cable Diagram 1

Display (Connection Port)	Cable		Remarks
GP3000 (COM1) GP4000 ^{*1} (COM1) SP5000 ^{*2} (COM1/2) SP-5B00 (COM1) ST3000 (COM1) ST6000 (COM1) STM6000 (COM1) STC6000 (COM1) ET6000 (COM1) LT3000 (COM1) IPC ^{*3} PC/AT	1A	User-created cable	Cable length: 15m or less
GP-4105 (COM1) GP-4115T (COM1) GP-4115T3 (COM1)	1B	User-created cable	Cable length: 15m or less
LT-4*01TM (COM1) LT-Rear Module (COM1)	1C	RJ45 RS-232C Cable (5m) by Pro-face PFXZLMCBJR21	Cable length: 5m or less

*1 All GP4000 models except GP-4100 Series and GP-4203T

*2 Except SP-5B00

*3 Available only with COM ports that support RS-232C.

☞ ■ IPC COM Port (page 9)

1A)

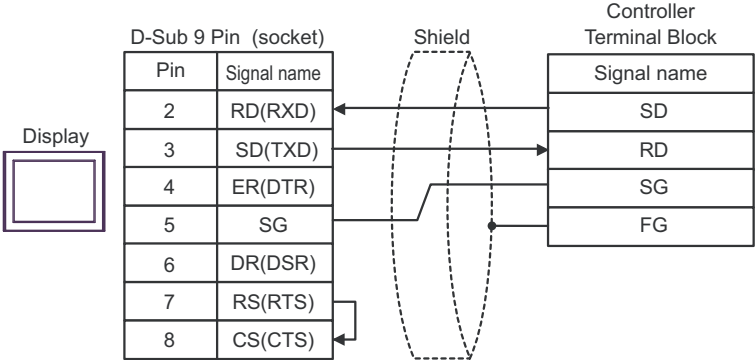

1B)

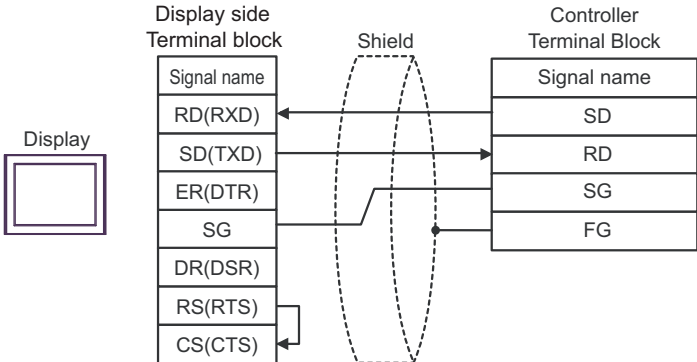

1C)

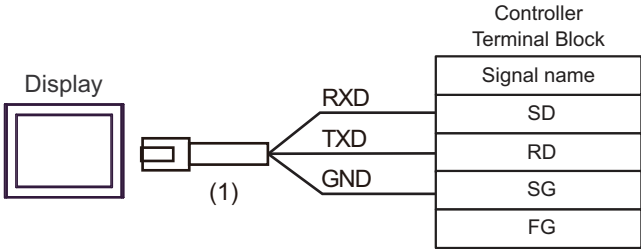

Number	Name	Notes
(1)	RJ45 RS-232C Cable (5m) by Pro-face PFXZLMCBRJR21	

Cable Diagram 2

Display (Connection Port)	Cable		Remarks
GP3000 ^{*1} (COM1) AGP-3302B (COM2) GP-4*01TM (COM1) GP-Rear Module (COM1) ST3000 ^{*2} (COM2) LT3000 (COM1) IPC ^{*3}	2A	COM port conversion adapter by Pro-face. CA3-ADPCOM-01 + Connector terminal block conversion adapter by Pro-face CA3-ADPTRM-01 + User-created cable	Cable length: 500m or less
	2B	User-created cable	
GP3000 ^{*4} (COM2)	2C	Online adapter by Pro-face CA4-ADPONL-01 + Connector terminal block conversion adapter by Pro-face CA3-ADPTRM-01 + User-created cable	Cable length: 500m or less
	2D	Online adapter by Pro-face CA4-ADPONL-01 + User-created cable	
GP-4106 (COM1) GP-4116T (COM1)	2E	User-created cable	Cable length: 500m or less
GP4000 ^{*5} (COM2) GP-4201T (COM1) SP5000 ^{*6} (COM1/2) SP-5B00 (COM2) ST6000 ^{*7} (COM2) ST-6200 (COM1) STM6000 (COM1) STC6000 (COM1) ET6000 ^{*8} (COM2) PS6000 (Basic Box) (COM1/2)	2F	RS-422 terminal block conversion adapter by Pro-face PFXZCBADTM1 ^{*9} + User-created cable	Cable length: 500m or less
	2B	User-created cable	
PE-4000B ^{*10} PS5000 ^{*10} PS6000 (Optional Interface) ^{*10}	2G	User-created cable	Cable length: 500m or less

*1 All GP3000 models except AGP-3302B

*2 Except AST-3211A and AST-3302B

*3 Available only with COM ports that support RS-422/485 (4wire). (Except PE-4000B, PS5000, and PS6000)
 ■ IPC COM Port (page 9)

*4 All GP3000 models except the GP-3200 Series and AGP-3302B

*5 All GP4000 models except GP-4100 series, GP-4*01TM, GP-Rear Module, GP-4201T and GP-4*03T

*6 Except SP-5B00

*7 Except ST-6200

*8 Due to the COM port specifications, flow control is not possible. Omit wiring the control pins on the Display side of the cable diagram.

- *9 When using a Terminal Block Conversion Adapter (CA3-ADPTRM-01) instead of the RS-422 Terminal Block Conversion Adapter, refer to Cable Diagram 2A.
- *10 Available only with COM ports that support RS-422/485 (4wire).
☞ ■ IPC COM Port (page 9)

2A)

- 1:1 Connection

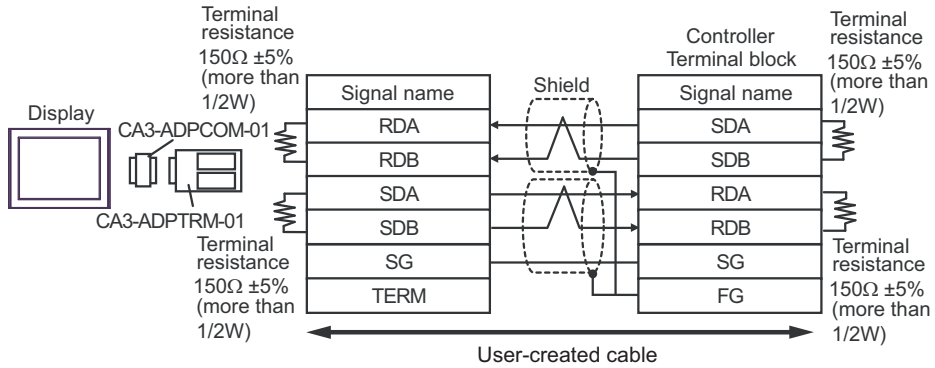

- 1:n Connection

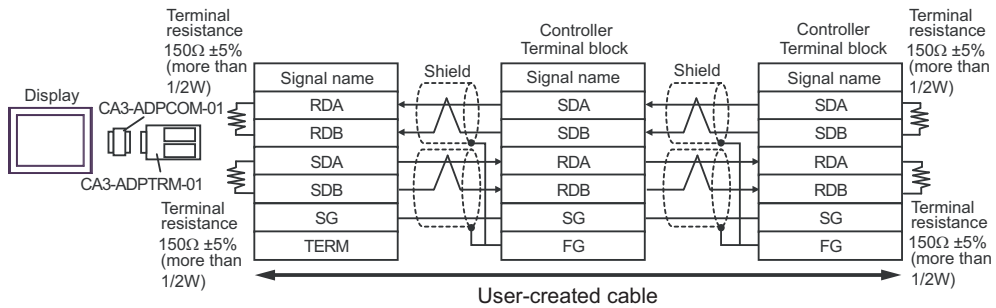

2B)

- 1:1 Connection

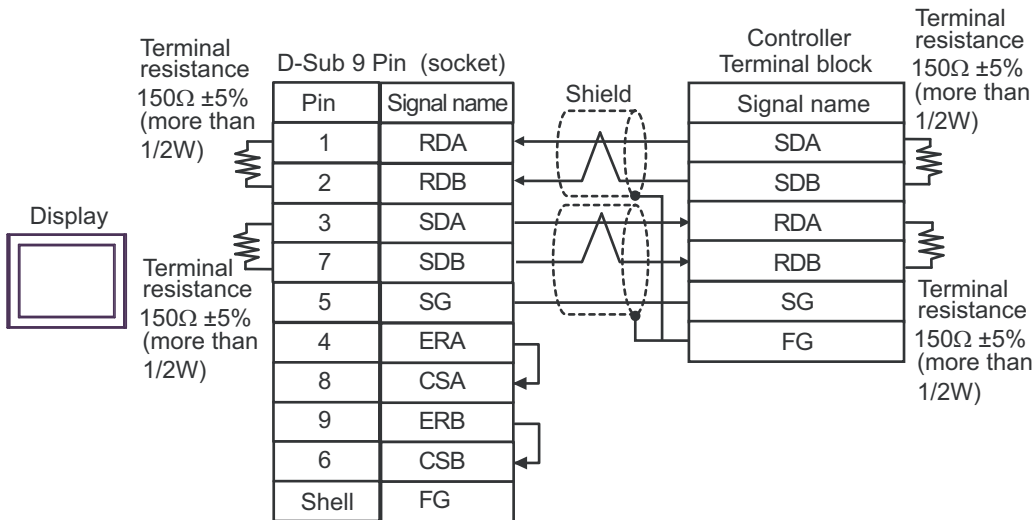

- 1:n Connection

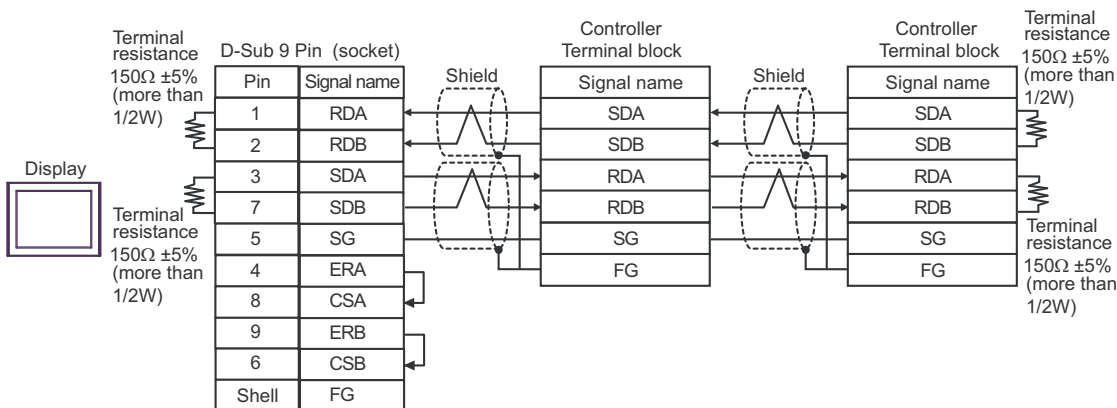

2C)

- 1:1 Connection

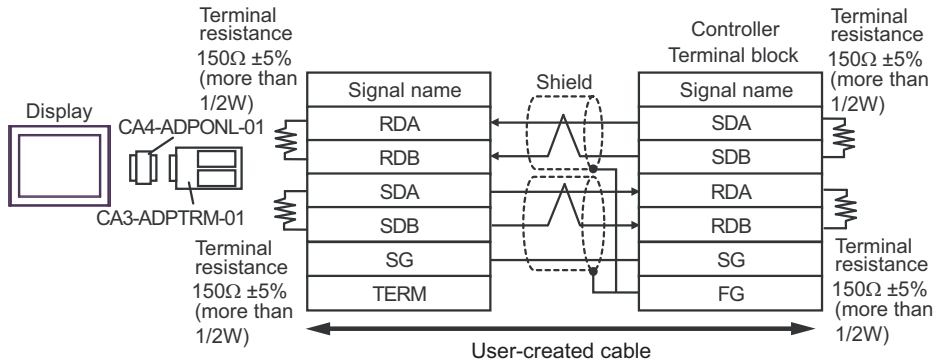

- 1:n Connection

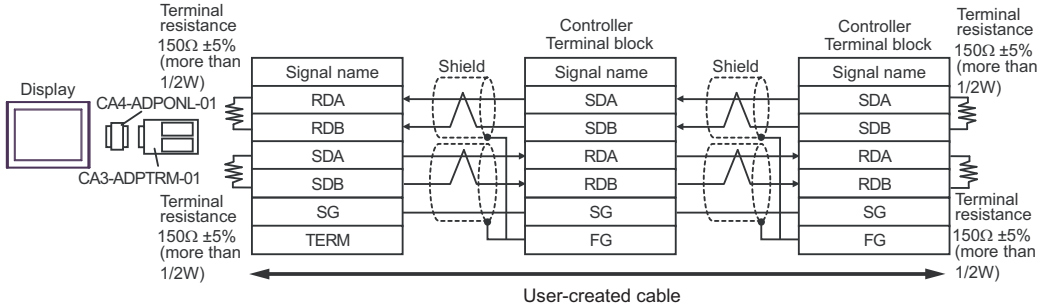

2D)

- 1:1 Connection

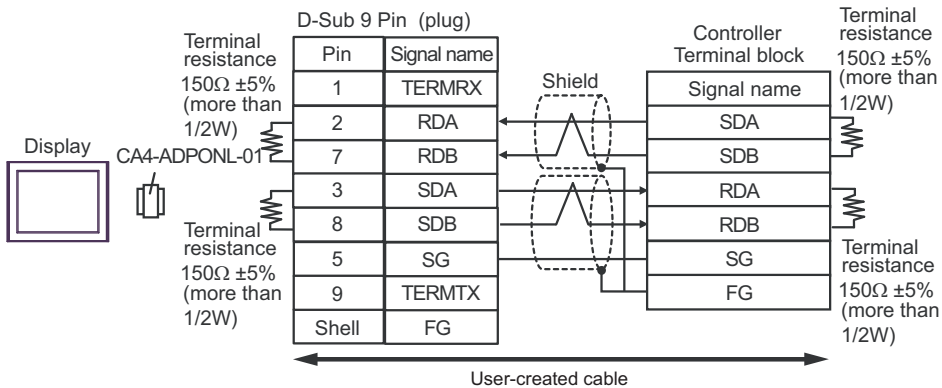

- 1:n Connection

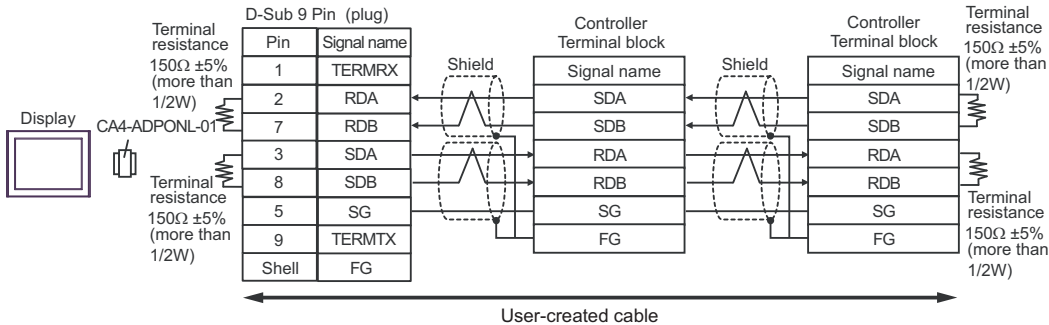

2E)

- 1:1 Connection

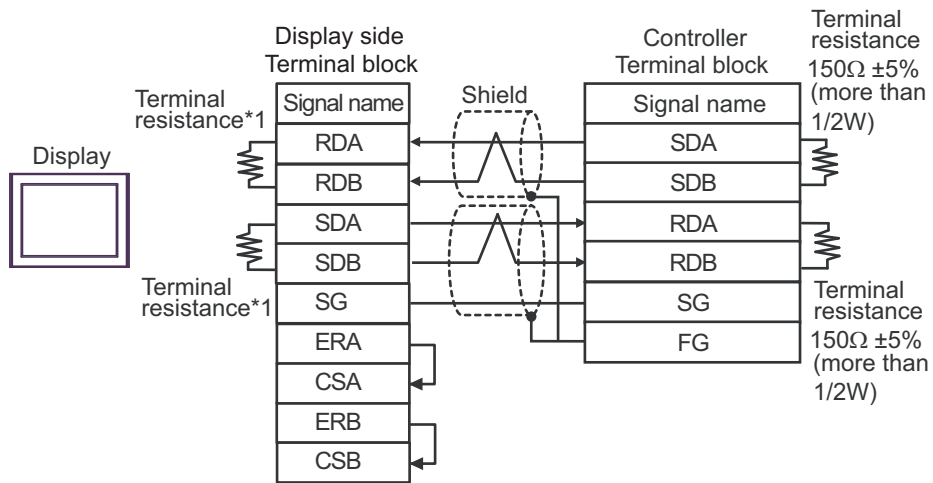

- 1:n Connection

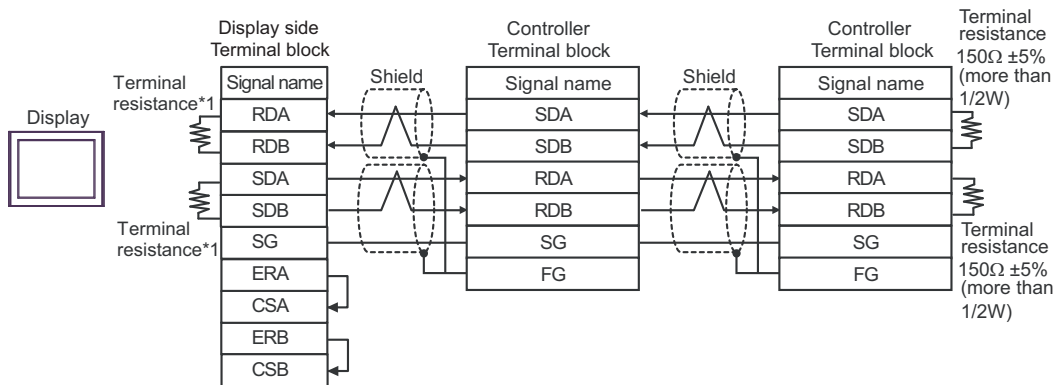

*1 The resistance in the Display is used as the termination resistance. Set the value of the DIP Switch on the rear of the Display as shown in the table below.

DIP Switch No.	Set Value
1	ON
2	ON
3	ON
4	ON

2F)

- 1:1 Connection

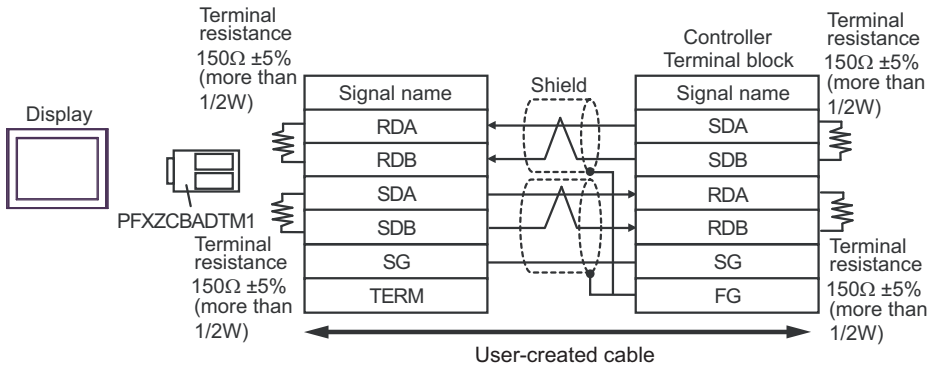

- 1:n Connection

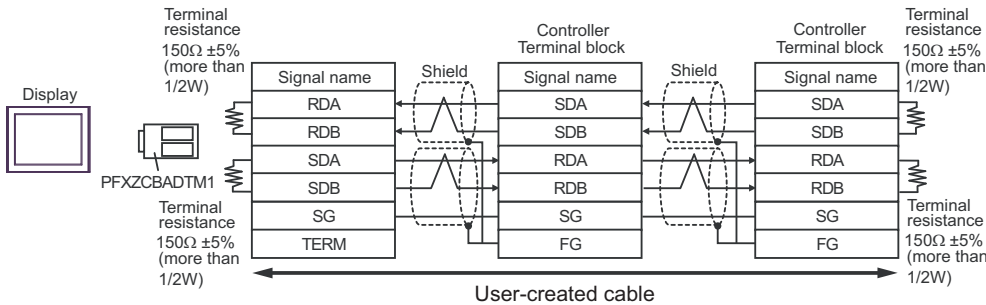

2G)

- 1:1 Connection

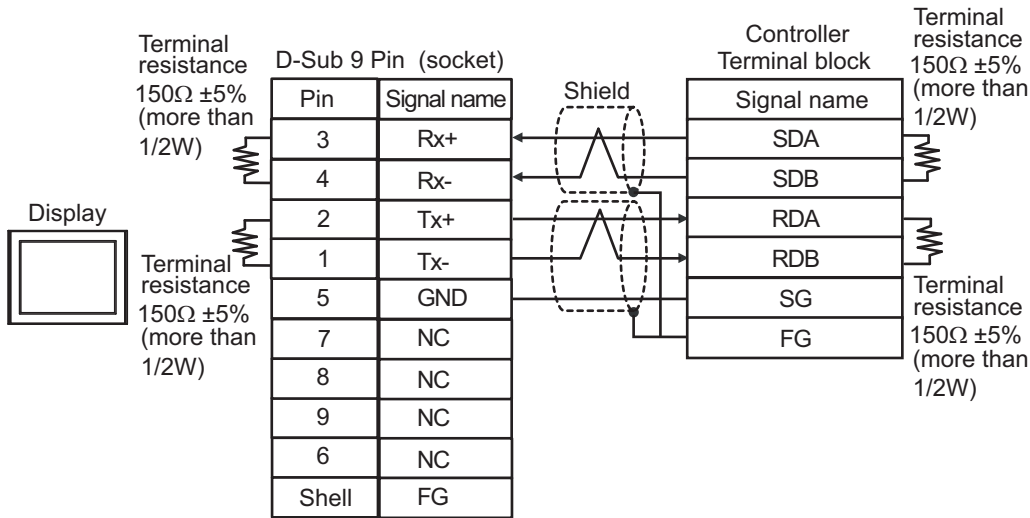

- 1:n Connection

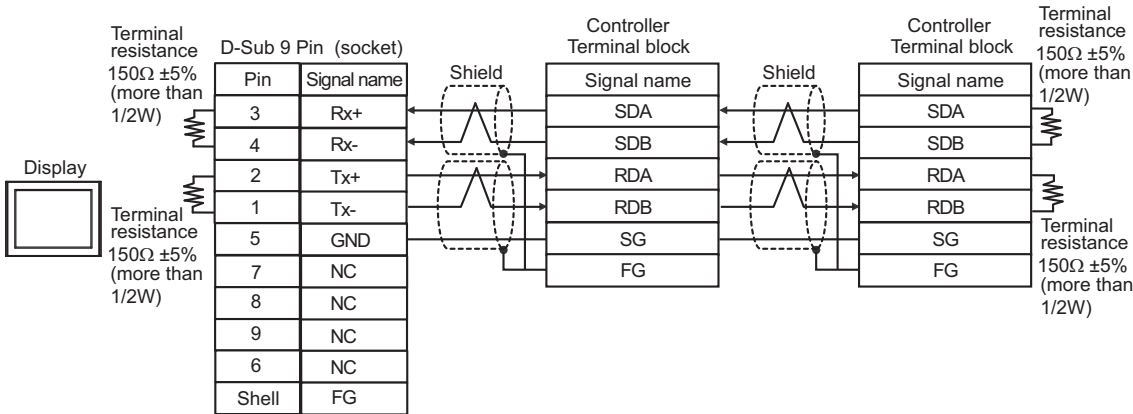

Cable Diagram 3

Display (Connection Port)	Cable		Remarks
GP3000* ¹ (COM1) AGP-3302B (COM2) GP-4*01TM (COM1) GP-Rear Module (COM1) ST3000* ² (COM2) LT3000 (COM1)	3A	COM port conversion adapter by Pro-face. CA3-ADPCOM-01 + Connector terminal block conversion adapter by Pro-face CA3-ADPTRM-01 + User-created cable	Cable length: 500m or less
	3B	User-created cable	
GP3000* ³ (COM2)	3C	Online adapter by Pro-face CA4-ADPONL-01 + Connector terminal block conversion adapter by Pro-face CA3-ADPTRM-01 + User-created cable	Cable length: 500m or less
	3D	Online adapter by Pro-face CA4-ADPONL-01 + User-created cable	
IPC* ⁴	3E	COM port conversion adapter by Pro-face. CA3-ADPCOM-01 + Connector terminal block conversion adapter by Pro-face CA3-ADPTRM-01 + User-created cable	Cable length: 500m or less
	3F	User-created cable	
GP-4106 (COM1) GP-4116T (COM1)	3G	User-created cable	Cable length: 500m or less
GP-4107 (COM1) GP-4*03T* ⁵ (COM2) GP-4203T (COM1)	3H	User-created cable	Cable length: 500m or less
GP4000* ⁶ (COM2) GP-4201T (COM1) SP5000* ⁷ (COM1/2) SP-5B00 (COM2) ST6000* ⁸ (COM2) ST-6200 (COM1) STM6000 (COM1) STC6000 (COM1) ET6000* ⁹ (COM2) PS6000 (Basic Box) (COM1/2)	3I	RS-422 terminal block conversion adapter by Pro-face PFXZCBADTM1* ¹⁰ + User-created cable	Cable length: 500m or less
	3B	User-created cable	
LT-4*01TM (COM1) LT-Rear Module (COM1)	3J	RJ45 RS-485 Cable (5m) by Pro-face PFXZLMCBJR81	Cable length: 200m or less
PE-4000B* ¹¹ PS5000* ¹¹ PS6000 (Optional Interface)* ¹¹	3K	User-created cable	Cable length: 500m or less

*1 All GP3000 models except AGP-3302B

- *2 Except AST-3211A and AST-3302B
- *3 All GP3000 models except the GP-3200 Series and AGP-3302B
- *4 Available only with COM ports that support RS-422/485 (2wire). (Except PE-4000B, PS5000, and PS6000)
 ☞ ■ IPC COM Port (page 9)
- *5 Except GP-4203T
- *6 All GP4000 models except GP-4100 series, GP-4*01TM, GP-Rear Module, GP-4201T and GP-4*03T
- *7 Except SP-5B00
- *8 Except ST-6200
- *9 Due to the COM port specifications, flow control is not possible. Omit wiring the control pins on the Display side of the cable diagram.
- *10 When using a Terminal Block Conversion Adapter (CA3-ADPTRM-01) instead of the RS-422 Terminal Block Conversion Adapter, refer to Cable Diagram 3A.
- *11 Available only with COM ports that support RS-422/485 (2wire).
 ☞ ■ IPC COM Port (page 9)

3A)

- 1:1 Connection

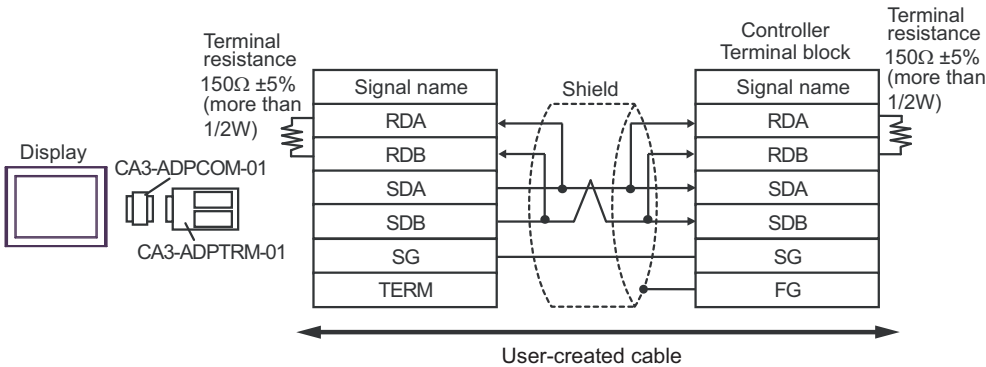

- 1:n Connection

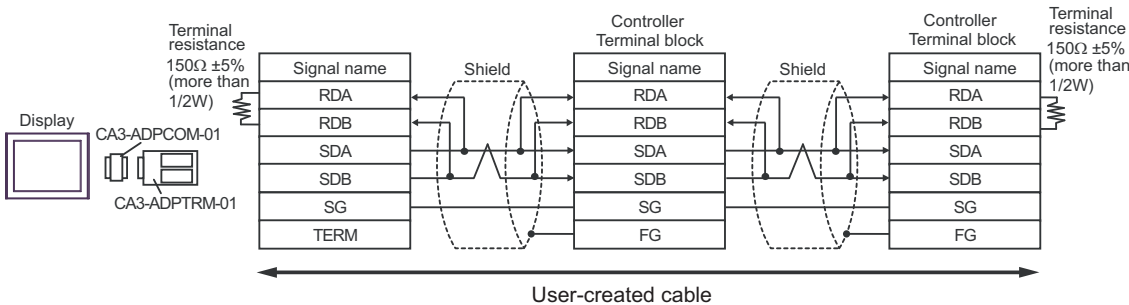

3B)

- 1:1 Connection

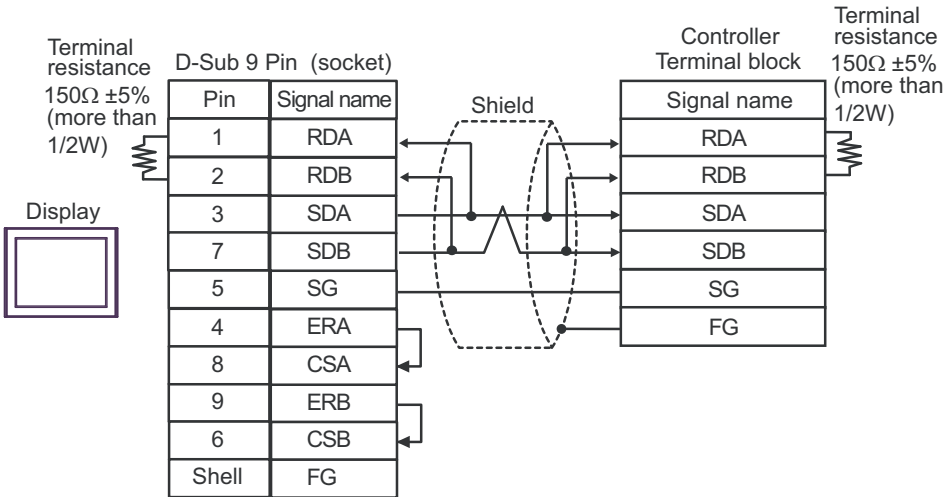

- 1:n Connection

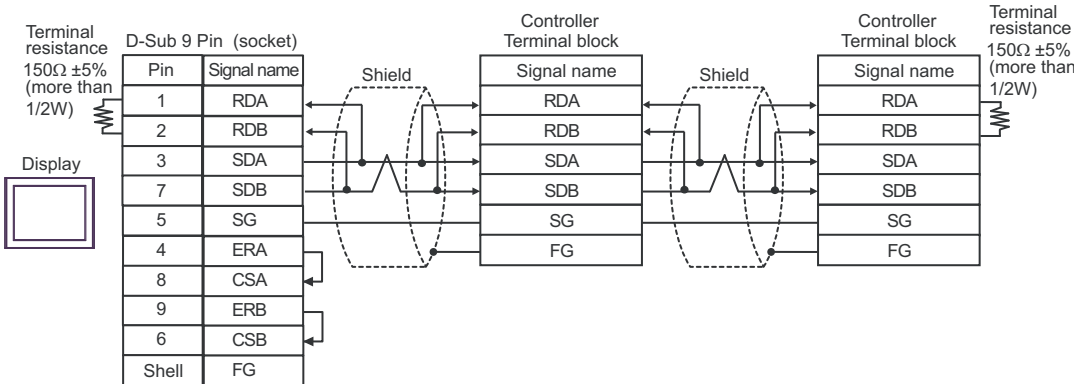

3C)

- 1:1 Connection

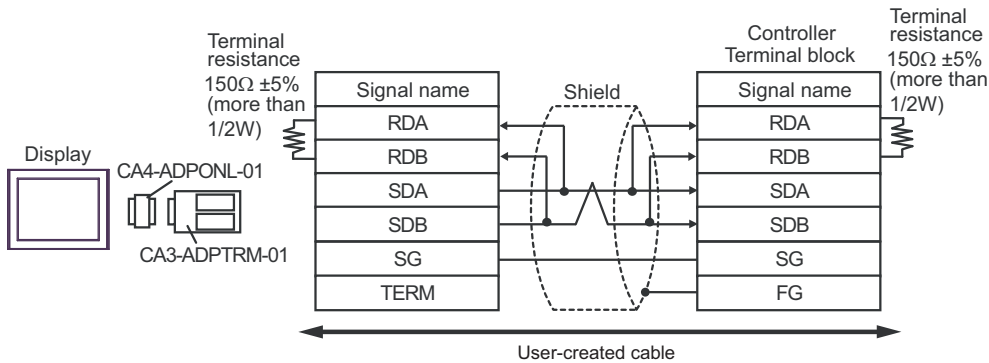

- 1:n Connection

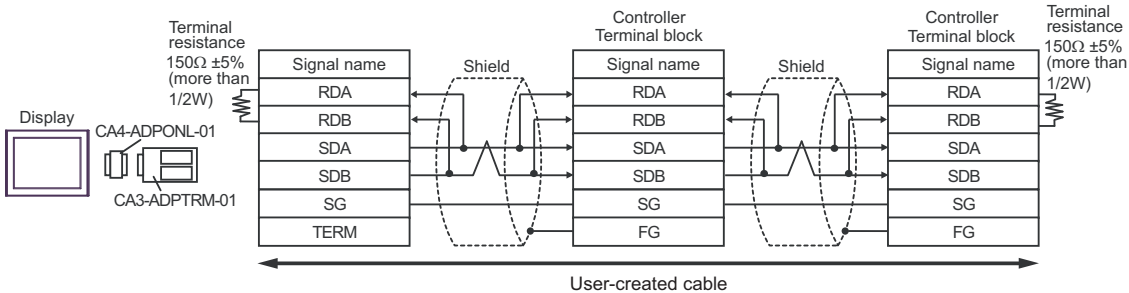

3D)

- 1:1 Connection

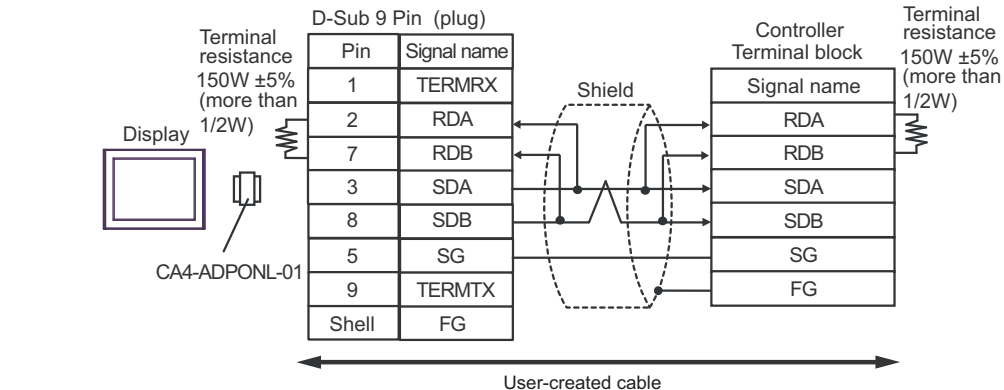

- 1:n Connection

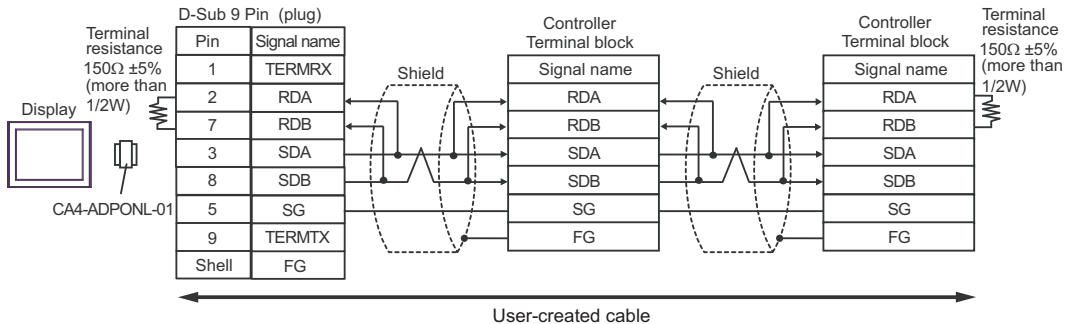

3E)

- 1:1 Connection

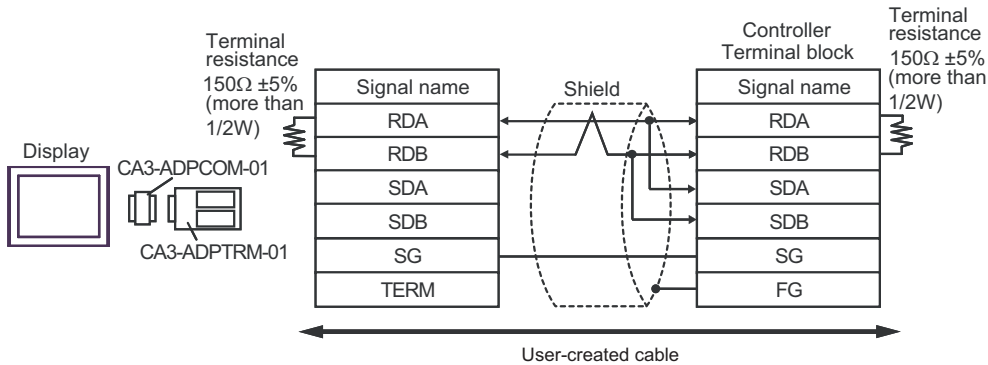

- 1:n Connection

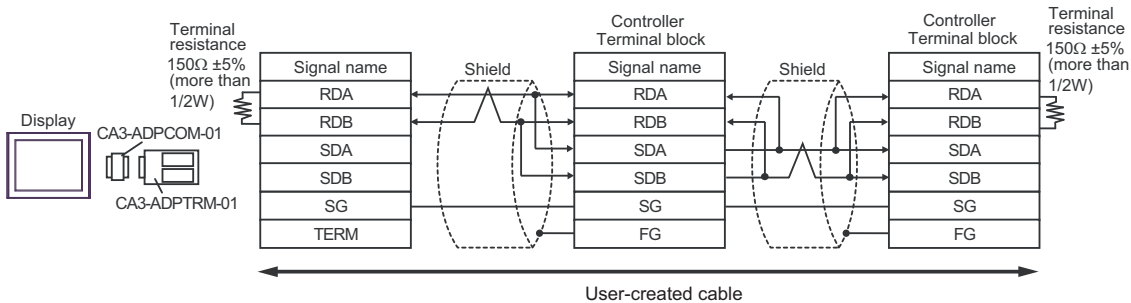

3F)

- 1:1 Connection

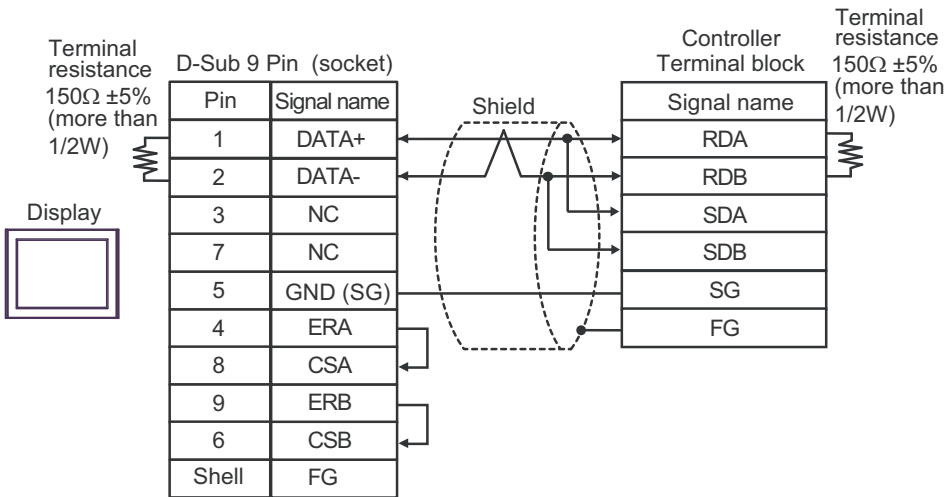

- 1:n Connection

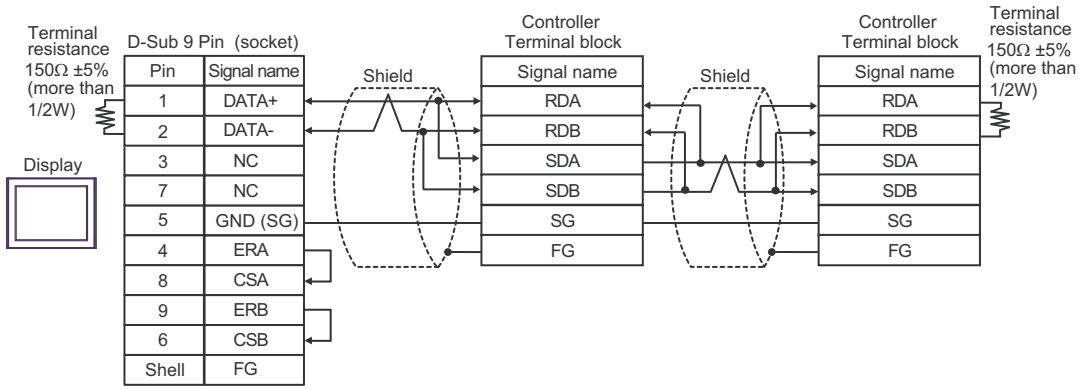

3G)

- 1:1 Connection

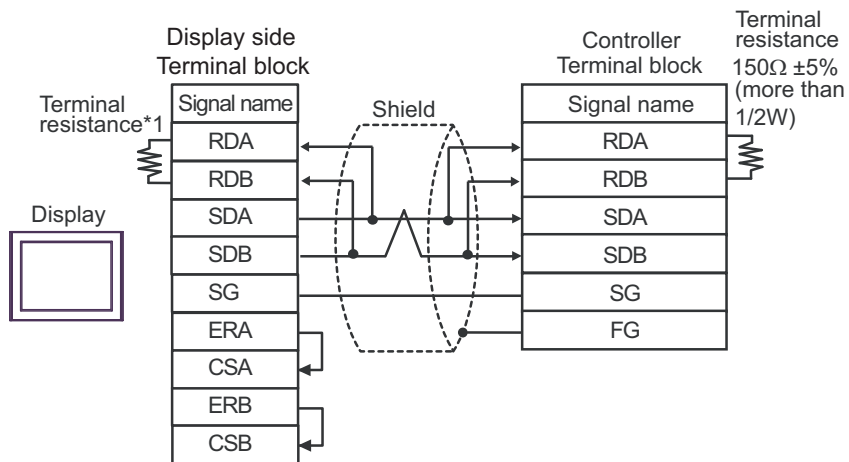

- 1:n Connection

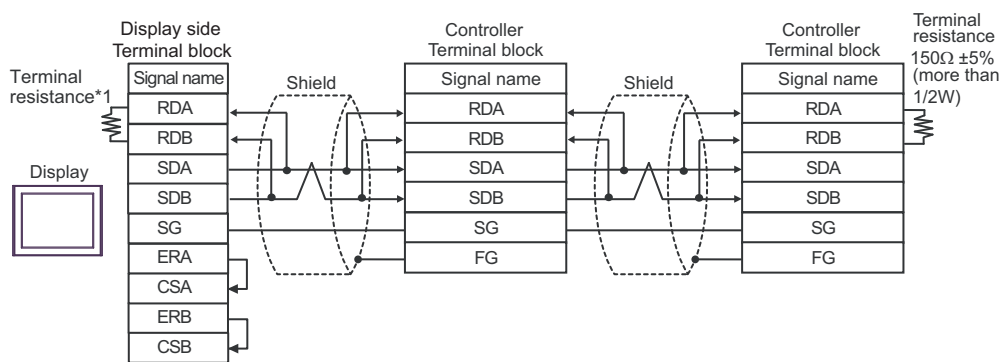

*1 The resistance in the Display is used as the termination resistance. Set the value of the DIP Switch on the rear of the Display as shown in the table below.

DIP Switch No.	Set Value
1	OFF
2	OFF
3	ON
4	ON

3H)

- 1:1 Connection

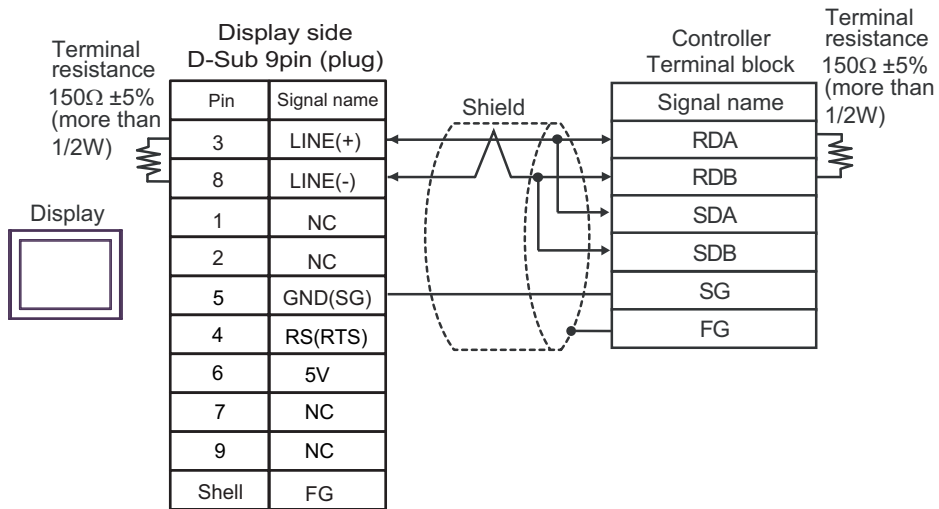

- 1:n Connection

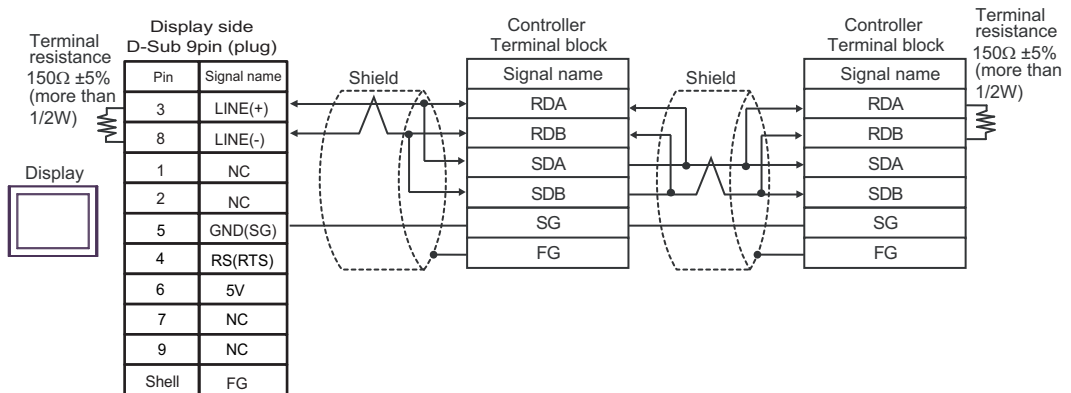

IMPORTANT

- The 5V output (Pin #6) on the Display is the power for the Siemens AG's PROFIBUS connector. Do not use it for other devices.

NOTE

- In COM on the GP-4107, the SG and FG terminals are isolated.

3I)

- 1:1 Connection

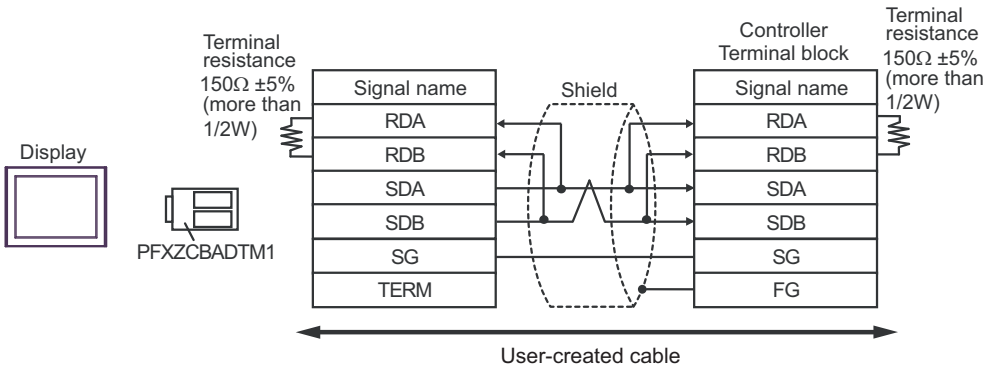

- 1:n Connection

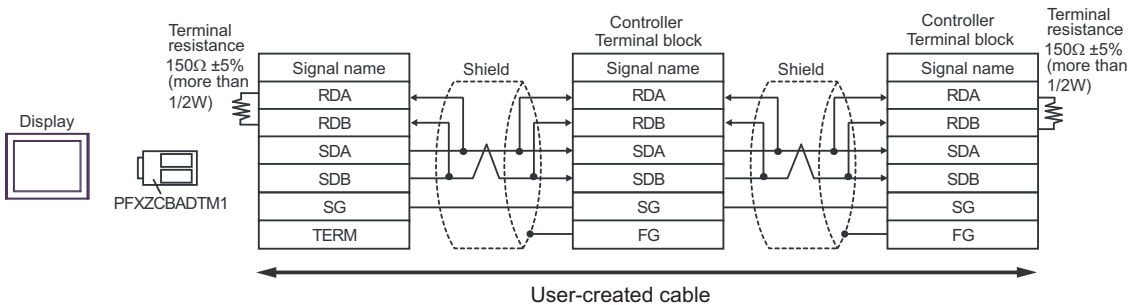

3J)

- 1:1 Connection

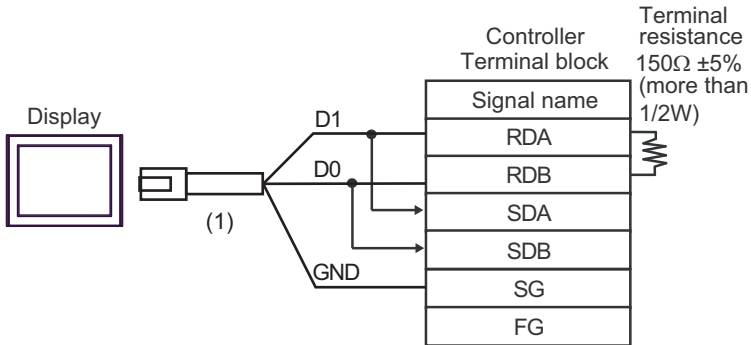

- 1:n Connection

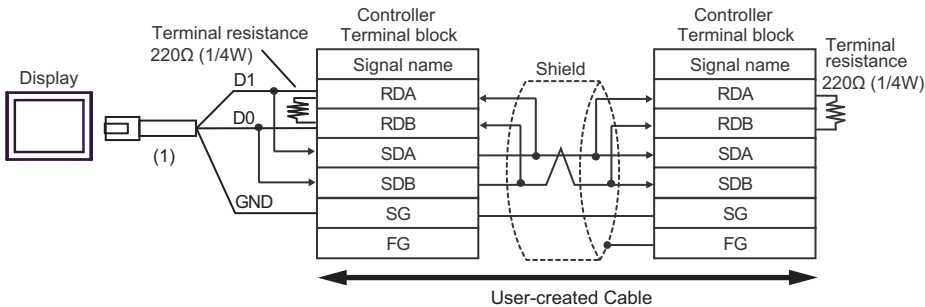

Number	Name	Notes
(1)	RJ45 RS-485 Cable (5m) by Pro-face PFXZLMCBRJR81	

3K)

- 1:1 Connection

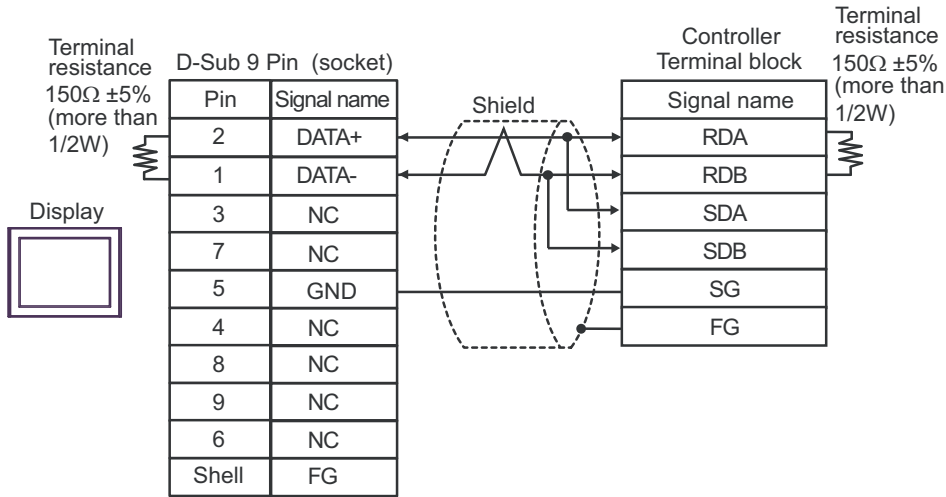

- 1:n Connection

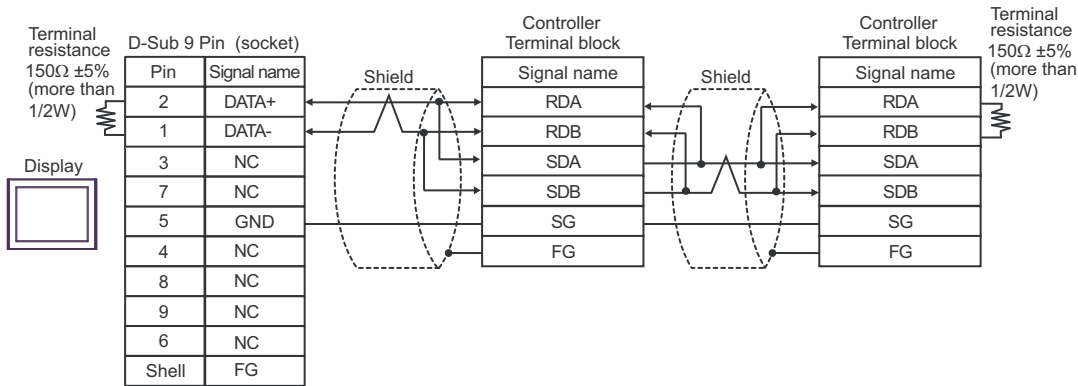

Cable Diagram 4

Display (Connection Port)	Cable		Remarks
GP3000* ¹ (COM1) AGP-3302B (COM2) GP-4*01TM (COM1) GP-Rear Module (COM1) ST3000* ² (COM2) LT3000 (COM1)	4A	COM port conversion adapter by Pro-face. CA3-ADPCOM-01 + Connector terminal block conversion adapter by Pro-face CA3-ADPTRM-01 + User-created cable	Cable length: 500m or less
	4B	User-created cable	
GP3000* ³ (COM2)	4C	Online adapter by Pro-face CA4-ADPONL-01 + Connector terminal block conversion adapter by Pro-face CA3-ADPTRM-01 + User-created cable	Cable length: 500m or less
	4D	Online adapter by Pro-face CA4-ADPONL-01 + User-created cable	
IPC* ⁴	4E	COM port conversion adapter by Pro-face. CA3-ADPCOM-01 + Connector terminal block conversion adapter by Pro-face CA3-ADPTRM-01 + User-created cable	Cable length: 500m or less
	4F	User-created cable	
GP-4106 (COM1) GP-4116T (COM1)	4G	User-created cable	Cable length: 500m or less
GP-4107 (COM1) GP-4*03T* ⁵ (COM2) GP-4203T (COM1)	4H	User-created cable	Cable length: 500m or less
GP4000* ⁶ (COM2) GP-4201T (COM1) SP5000* ⁷ (COM1/2) SP-5B00 (COM2) ST6000* ⁸ (COM2) ST-6200 (COM1) STM6000 (COM1) STC6000 (COM1) ET6000* ⁹ (COM2) PS6000 (Basic Box) (COM1/2)	4I	RS-422 terminal block conversion adapter by Pro-face PFXZCBADTM1* ¹⁰ + User-created cable	Cable length: 500m or less
	4B	User-created cable	
LT-4*01TM (COM1) LT-Rear Module (COM1)	4J	RJ45 RS-485 Cable (5m) by Pro-face PFXZLMCBJR81	Cable length: 200m or less
PE-4000B* ¹¹ PS5000* ¹¹ PS6000 (Optional Interface)* ¹¹	4K	User-created cable	Cable length: 500m or less

*1 All GP3000 models except AGP-3302B

- *2 Except AST-3211A and AST-3302B
- *3 All GP3000 models except the GP-3200 Series and AGP-3302B
- *4 Available only with COM ports that support RS-422/485 (2wire). (Except PE-4000B, PS5000, and PS6000)
 - ☞ ■ IPC COM Port (page 9)
- *5 Except GP-4203T
- *6 All GP4000 models except GP-4100 series, GP-4*01TM, GP-Rear Module, GP-4201T and GP-4*03T
- *7 Except SP-5B00
- *8 Except ST-6200
- *9 Due to the COM port specifications, flow control is not possible. Omit wiring the control pins on the Display side of the cable diagram.
- *10 When using a Terminal Block Conversion Adapter (CA3-ADPTRM-01) instead of the RS-422 Terminal Block Conversion Adapter, refer to Cable Diagram 4A.
- *11 Available only with COM ports that support RS-422/485 (2wire).
 - ☞ ■ IPC COM Port (page 9)

4A)

- 1:1 Connection

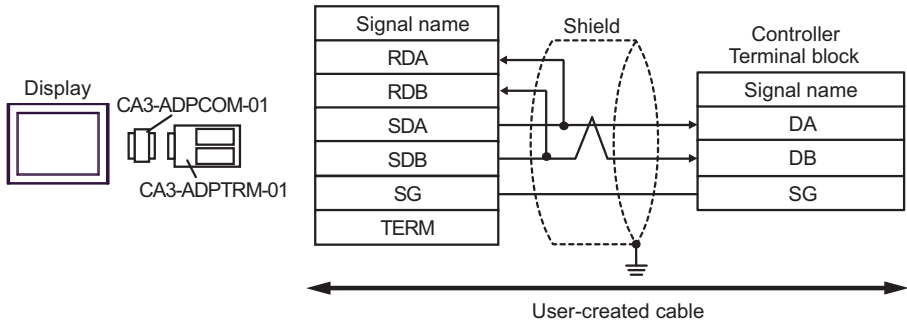

NOTE • No termination resistor is required.

- 1:n Connection

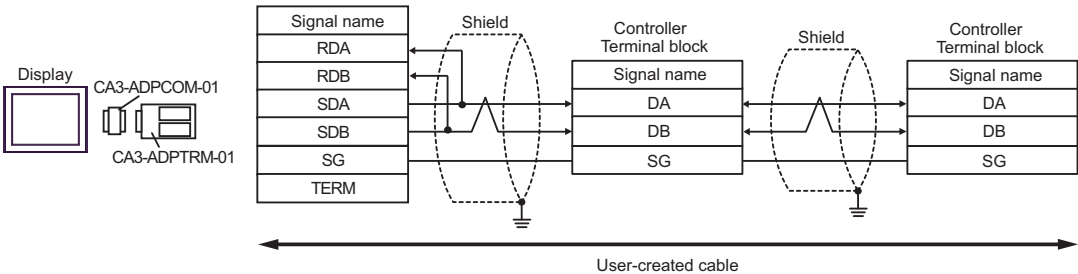

NOTE • No termination resistor is required.

4B)

- 1:1 Connection

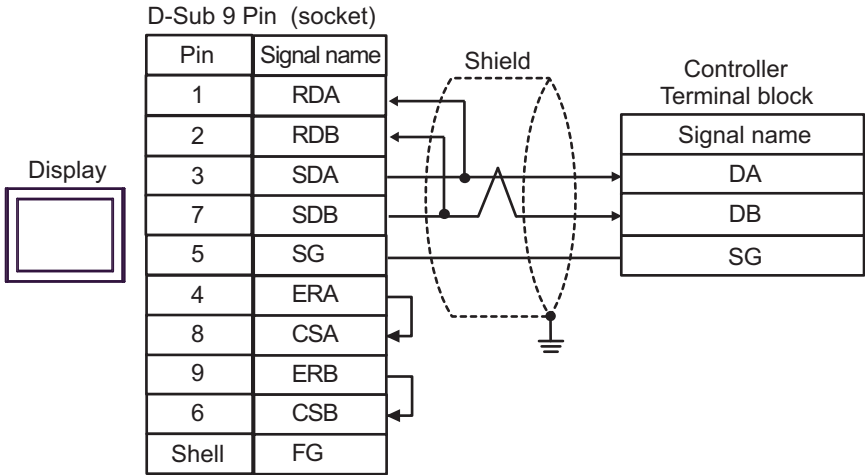

NOTE • No termination resistor is required.

- 1:n Connection

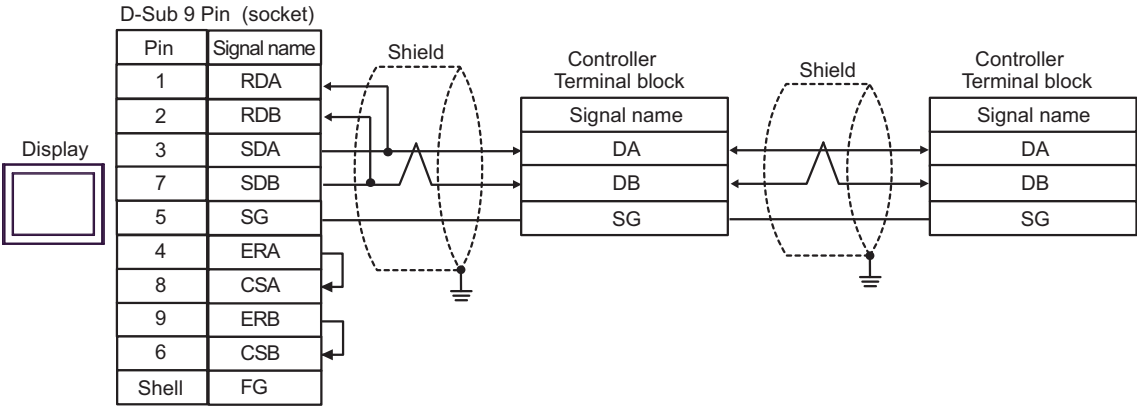

NOTE • No termination resistor is required.

4C)

- 1:1 Connection

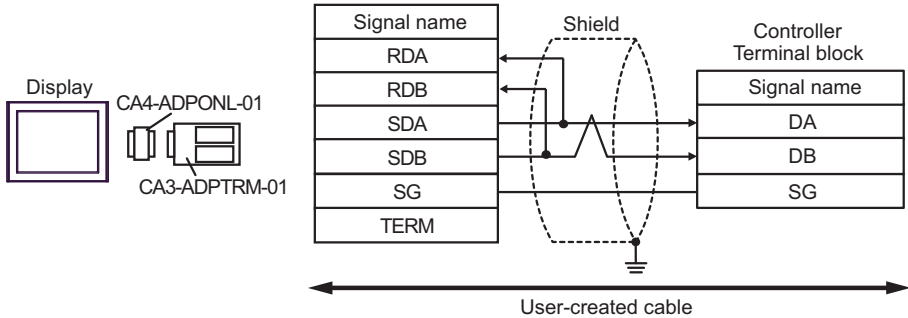

NOTE • No termination resistor is required.

- 1:n Connection

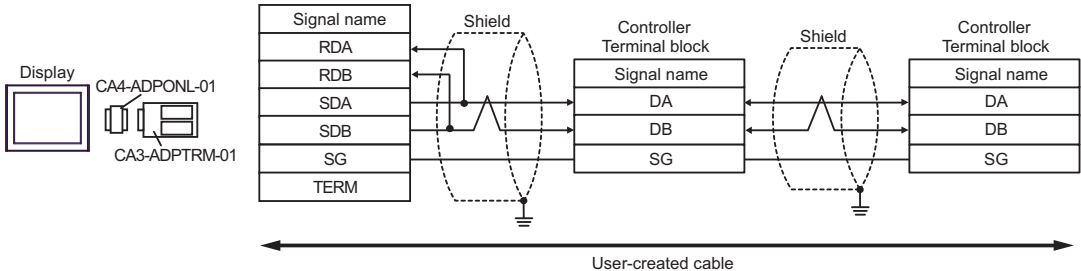

NOTE • No termination resistor is required.

4D)

- 1:1 Connection

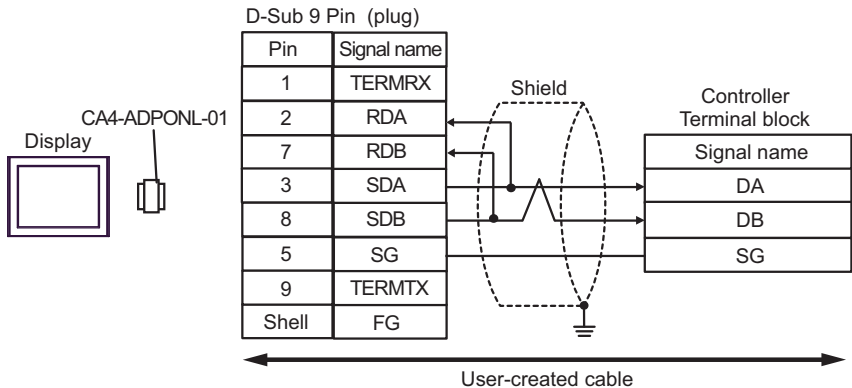

NOTE • No termination resistor is required.

- 1:n Connection

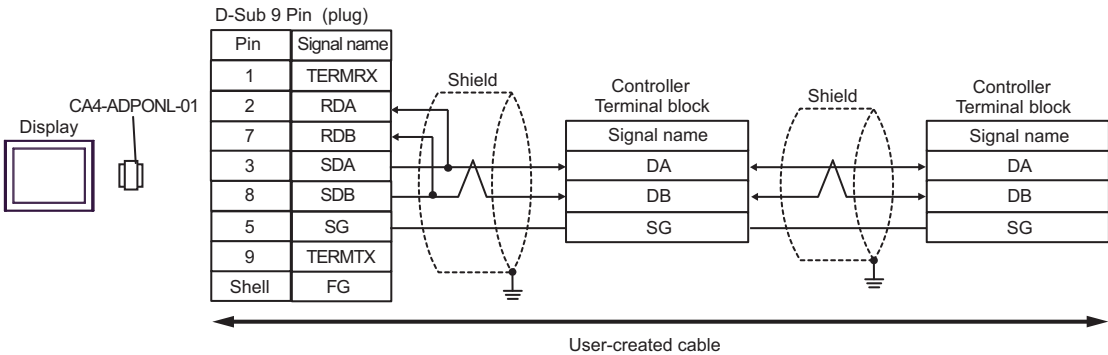

NOTE • No termination resistor is required.

4E)

- 1:1 Connection

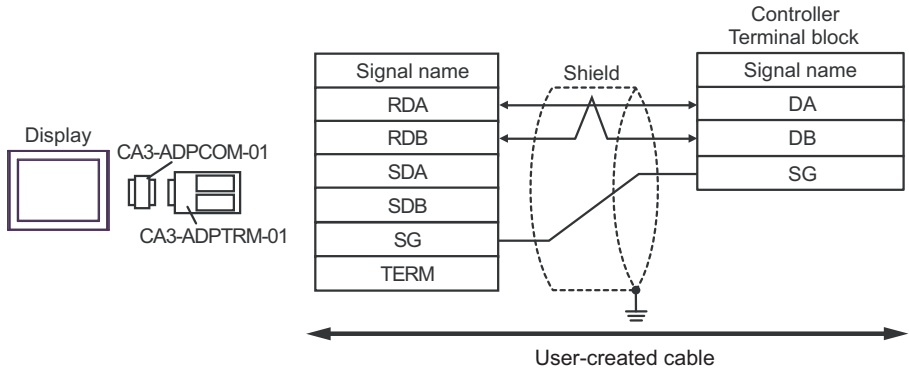

NOTE • No termination resistor is required.

- 1:n Connection

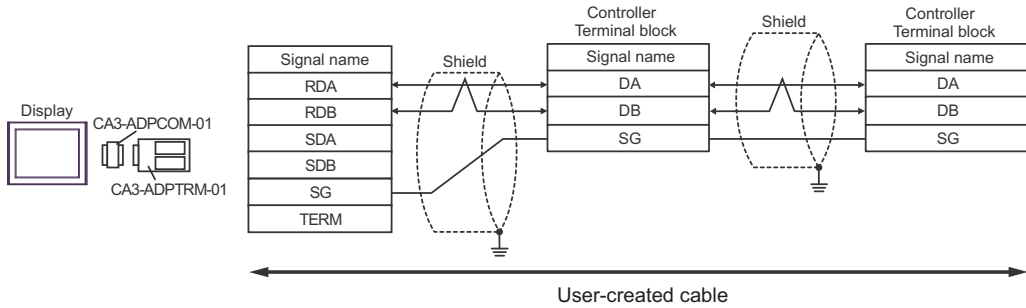

NOTE • No termination resistor is required.

4F)

- 1:1 Connection

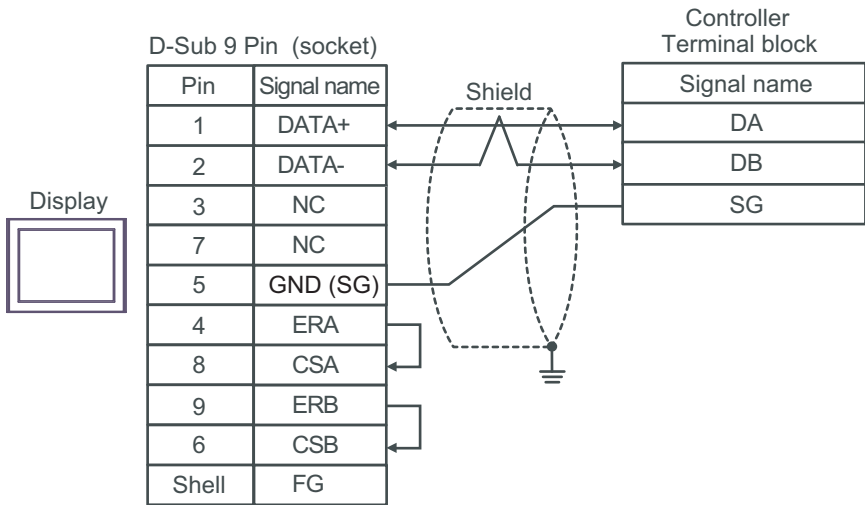

NOTE • No termination resistor is required.

- 1:n Connection

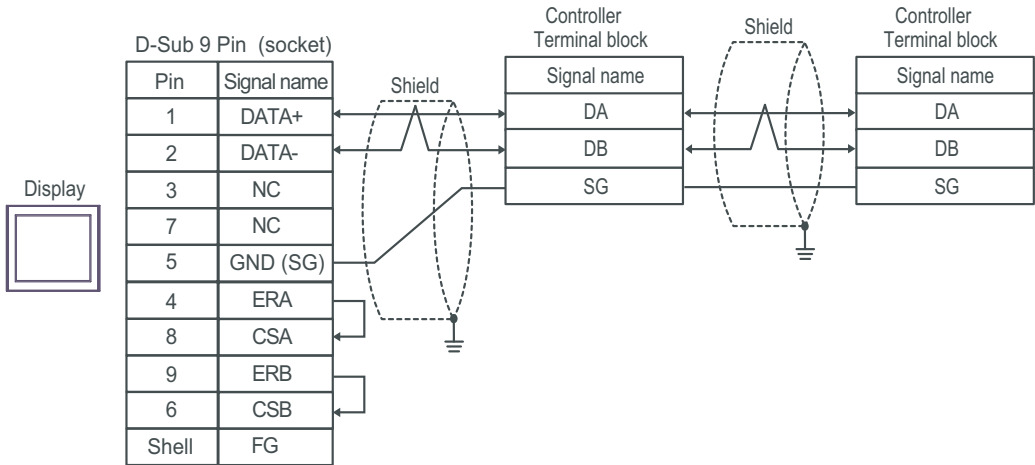

NOTE • No termination resistor is required.

4G)

- 1:1 Connection

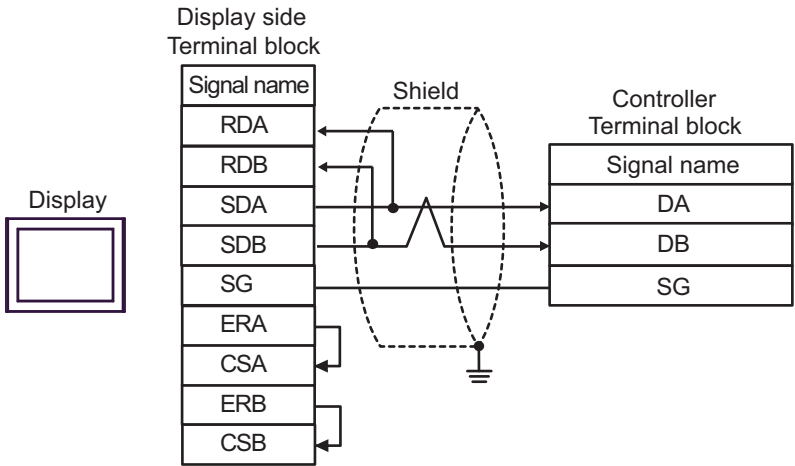

NOTE • No termination resistor is required.

- 1:n Connection

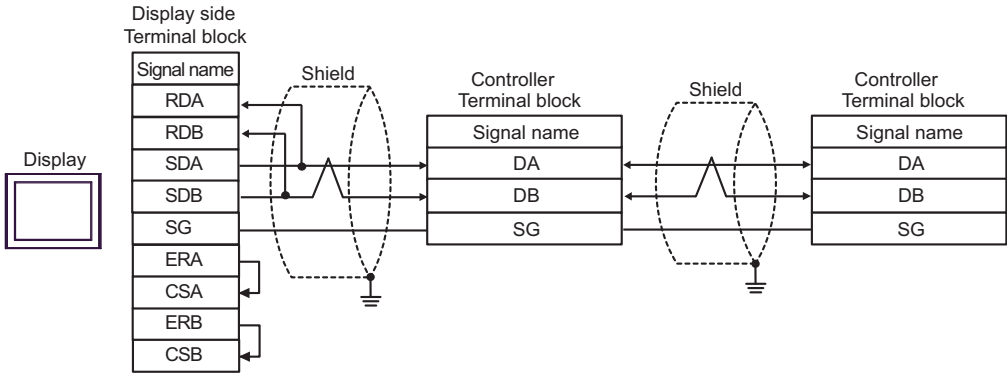

NOTE • No termination resistor is required.

4H)

- 1:1 Connection

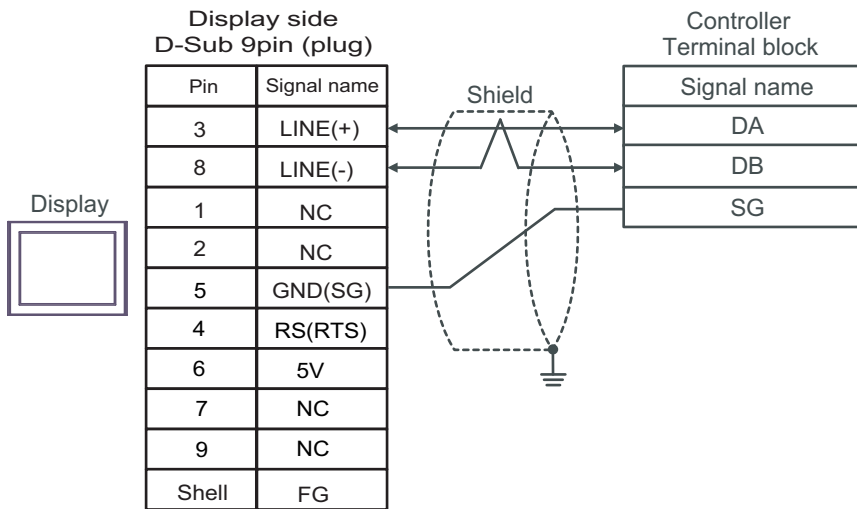
**NOTE**

- No termination resistor is required.

- 1:n Connection

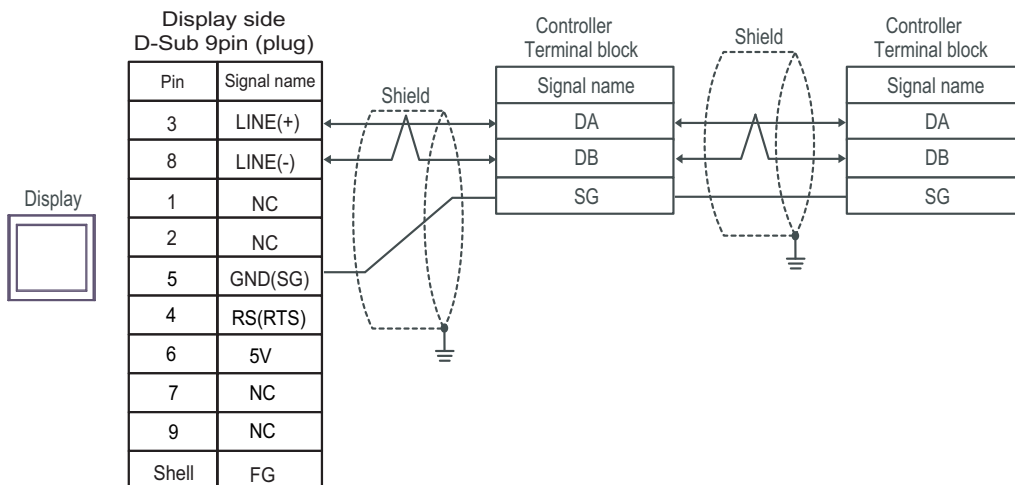
**IMPORTANT**

- The 5V output (Pin #6) on the Display is the power for the Siemens AG's PROFIBUS connector. Do not use it for other devices.

NOTE

- No termination resistor is required.
- In COM on the GP-4107, the SG and FG terminals are isolated.

4I)

- 1:1 Connection

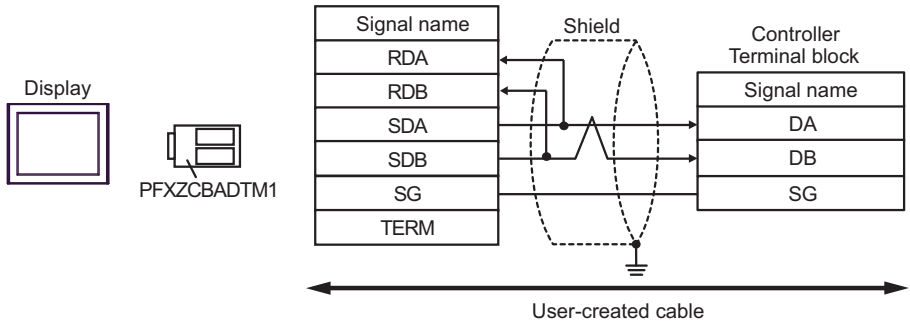

NOTE • No termination resistor is required.

- 1:n Connection

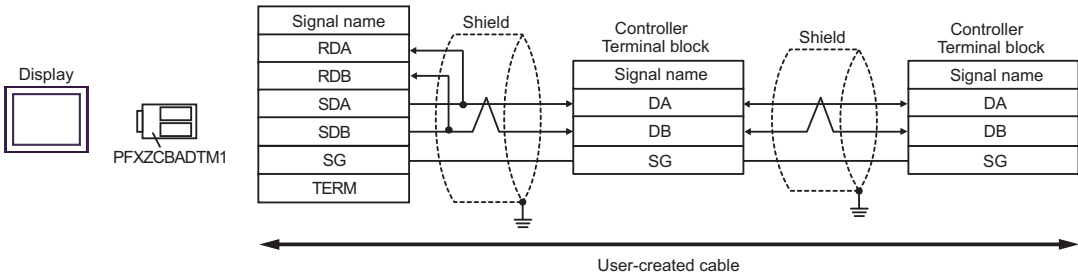

NOTE • No termination resistor is required.

- 4J)
 - 1:1 Connection

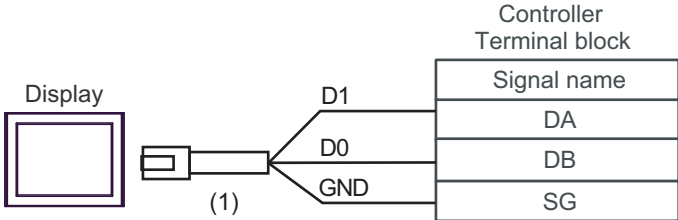

NOTE • No termination resistor is required.

- 1:n Connection

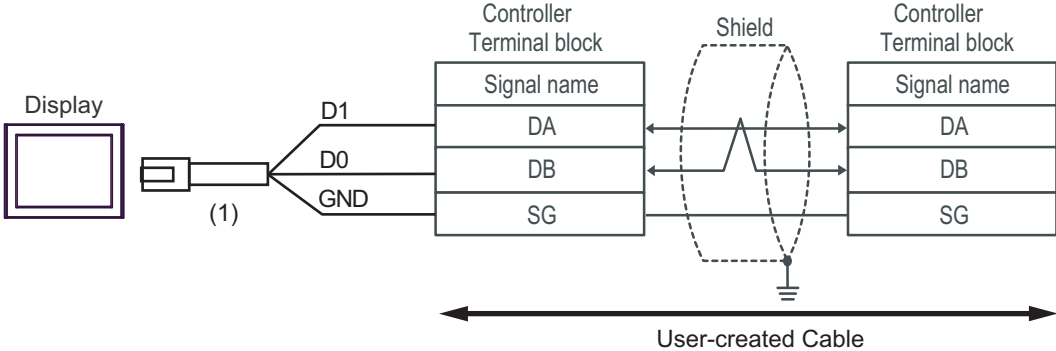

NOTE • No termination resistor is required.

Number	Name	Notes
(1)	RJ45 RS-485 Cable (5m) by Pro-face PFXZLMCBRJR81	

4K)

- 1:1 Connection

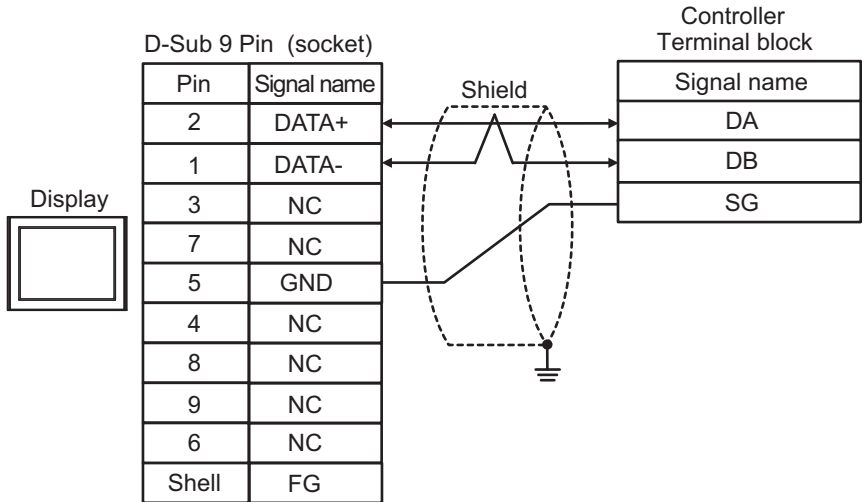

NOTE • No termination resistor is required.

- 1:n Connection

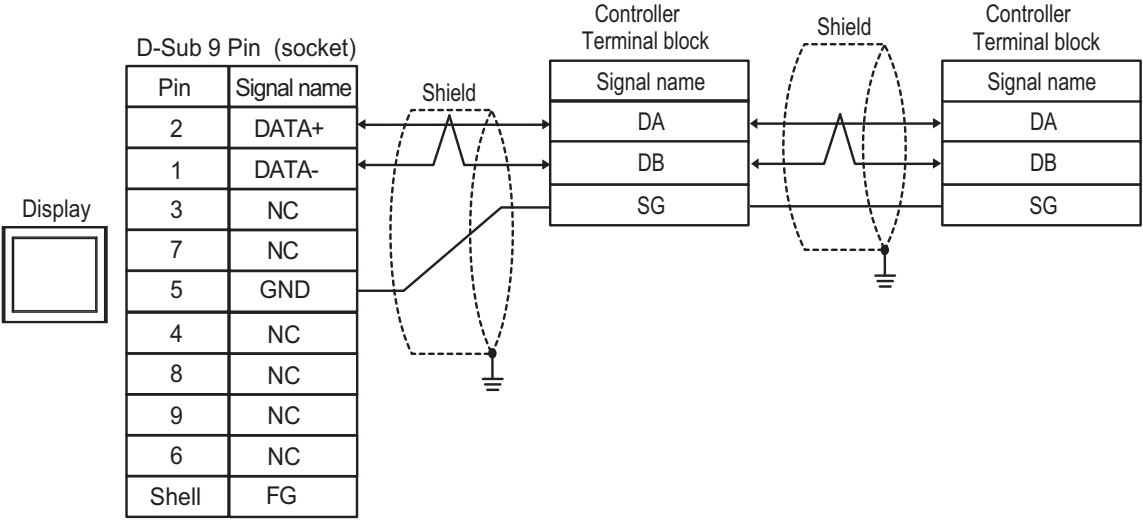

NOTE • No termination resistor is required.

Cable Diagram 5

Display (Connection Port)	Cable		Remarks
GP3000* ¹ (COM1) AGP-3302B (COM2) GP-4*01TM (COM1) GP-Rear Module (COM1) ST3000* ² (COM2) LT3000 (COM1)	5A	COM port conversion adapter by Pro-face. CA3-ADPCOM-01 + Connector terminal block conversion adapter by Pro-face CA3-ADPTRM-01 + User-created cable	Cable length: 500m or less
	5B	User-created cable	
GP3000* ³ (COM2)	5C	Online adapter by Pro-face CA4-ADPONL-01 + Connector terminal block conversion adapter by Pro-face CA3-ADPTRM-01 + User-created cable	Cable length: 500m or less
	5D	Online adapter by Pro-face CA4-ADPONL-01 + User-created cable	
IPC* ⁴	5E	COM port conversion adapter by Pro-face. CA3-ADPCOM-01 + Connector terminal block conversion adapter by Pro-face CA3-ADPTRM-01 + User-created cable	Cable length: 500m or less
	5F	User-created cable	
GP-4106 (COM1) GP-4116T (COM1)	5G	User-created cable	Cable length: 500m or less
GP-4107 (COM1) GP-4*03T* ⁵ (COM2) GP-4203T (COM1)	5H	User-created cable	Cable length: 500m or less
GP4000* ⁶ (COM2) GP-4201T (COM1) SP5000* ⁷ (COM1/2) SP-5B00 (COM2) ST6000* ⁸ (COM2) ST-6200 (COM1) STM6000 (COM1) STC6000 (COM1) ET6000* ⁹ (COM2) PS6000 (Basic Box) (COM1/2)	5I	RS-422 terminal block conversion adapter by Pro-face PFXZCBADTM1* ¹⁰ + User-created cable	Cable length: 500m or less
	5B	User-created cable	
LT-4*01TM (COM1) LT-Rear Module (COM1)	5J	RJ45 RS-485 Cable (5m) by Pro-face PFXZLMCBJR81	Cable length: 200m or less
PE-4000B* ¹¹ PS5000* ¹¹ PS6000 (Optional Interface)* ¹¹	5K	User-created cable	Cable length: 500m or less

*1 All GP3000 models except AGP-3302B

- *2 Except AST-3211A and AST-3302B
- *3 All GP3000 models except the GP-3200 Series and AGP-3302B
- *4 Available only with COM ports that support RS-422/485 (2wire). (Except PE-4000B, PS5000, and PS6000)
 ☞ ■ IPC COM Port (page 9)
- *5 Except GP-4203T
- *6 All GP4000 models except GP-4100 series, GP-4*01TM, GP-Rear Module, GP-4201T and GP-4*03T
- *7 Except SP-5B00
- *8 Except ST-6200
- *9 Due to the COM port specifications, flow control is not possible. Omit wiring the control pins on the Display side of the cable diagram.
- *10 When using a Terminal Block Conversion Adapter (CA3-ADPTRM-01) instead of the RS-422 Terminal Block Conversion Adapter, refer to Cable Diagram 5A.
- *11 Available only with COM ports that support RS-422/485 (2wire).
 ☞ ■ IPC COM Port (page 9)

5A)

- 1:1 Connection

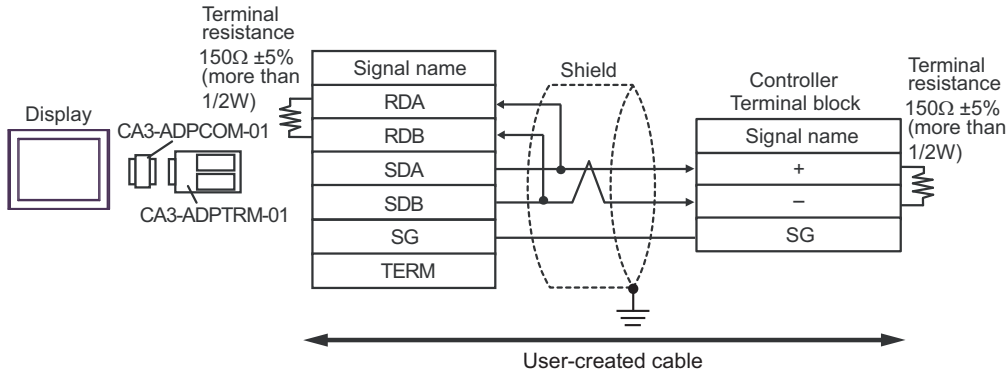

- 1:n Connection

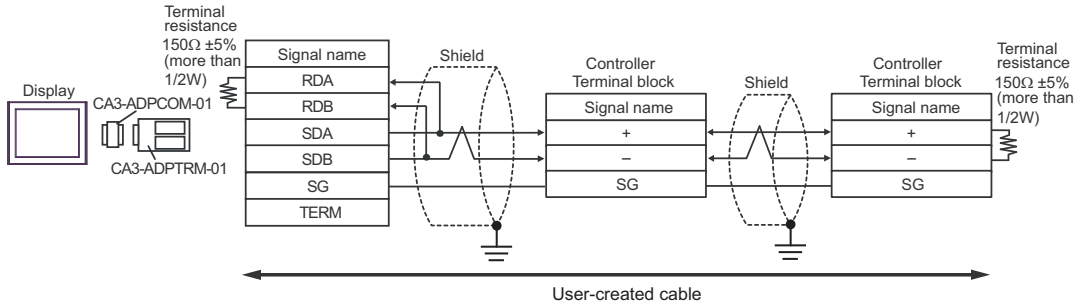

5B)

- 1:1 Connection

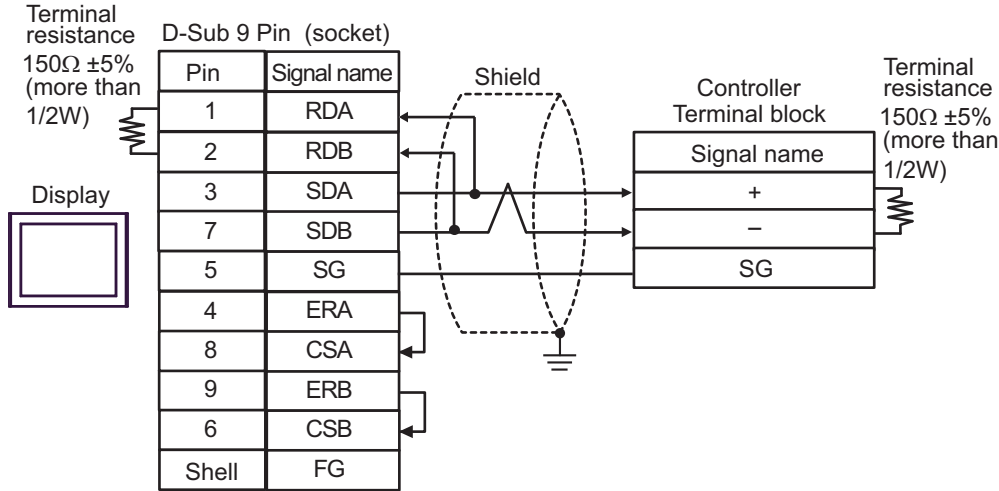

- 1:n Connection

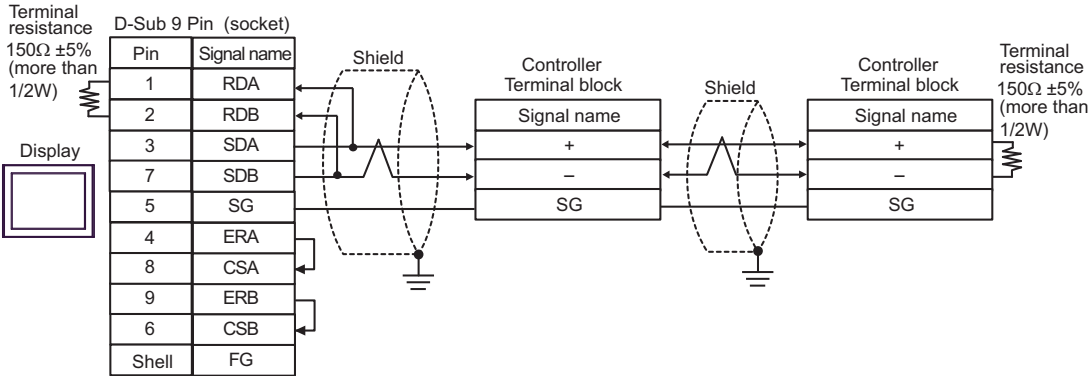

5C)

- 1:1 Connection

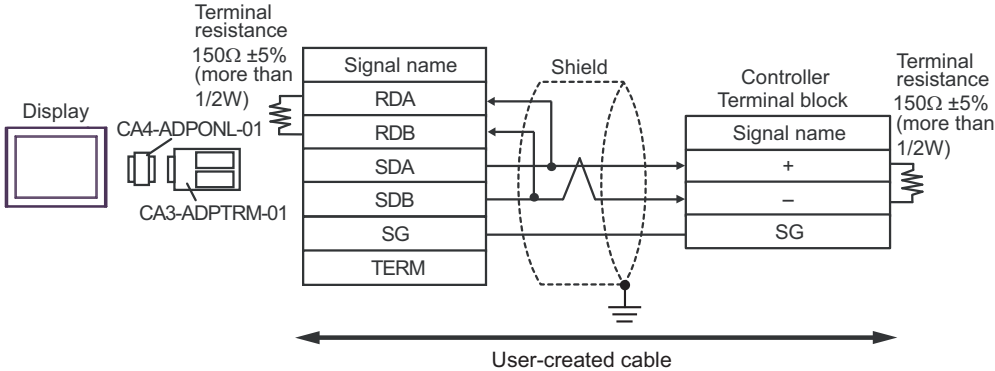

- 1:n Connection

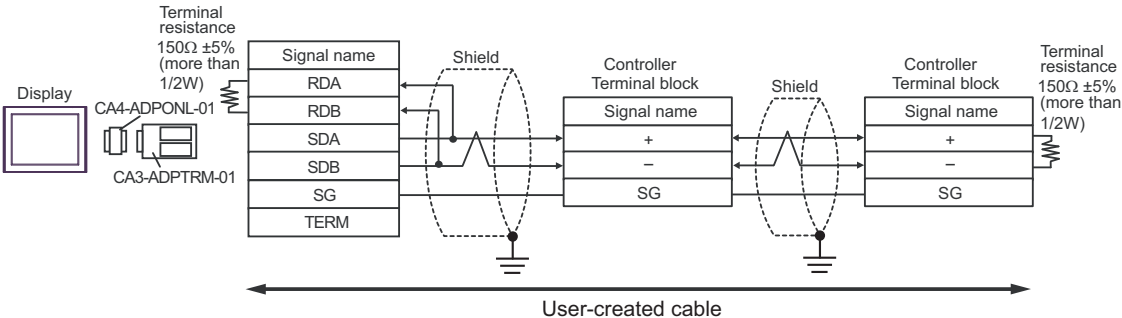

5D)

- 1:1 Connection

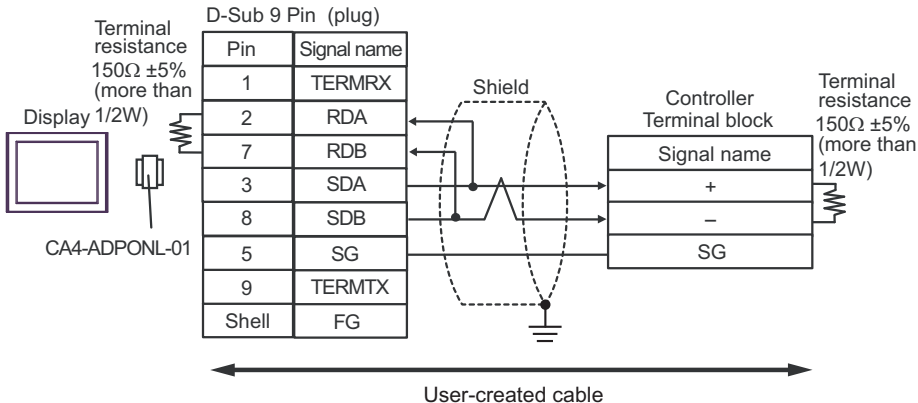

- 1:n Connection

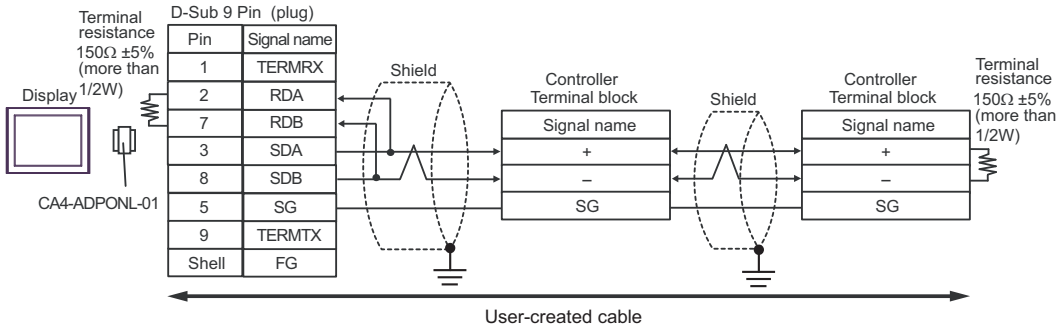

5E)

- 1:1 Connection

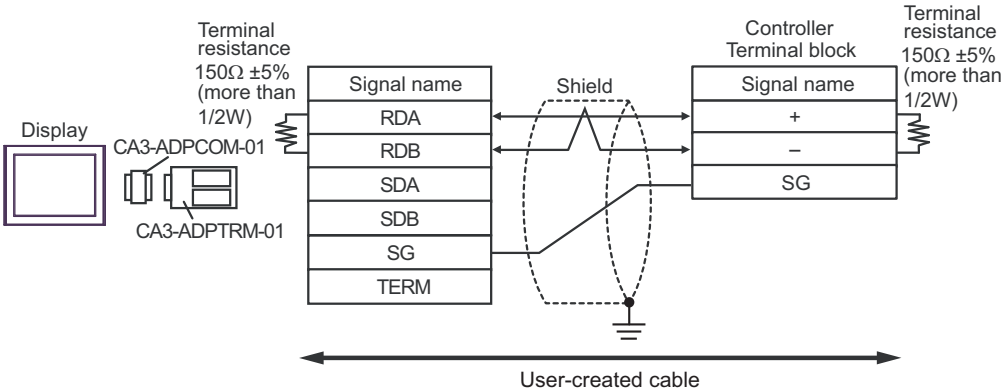

- 1:n Connection

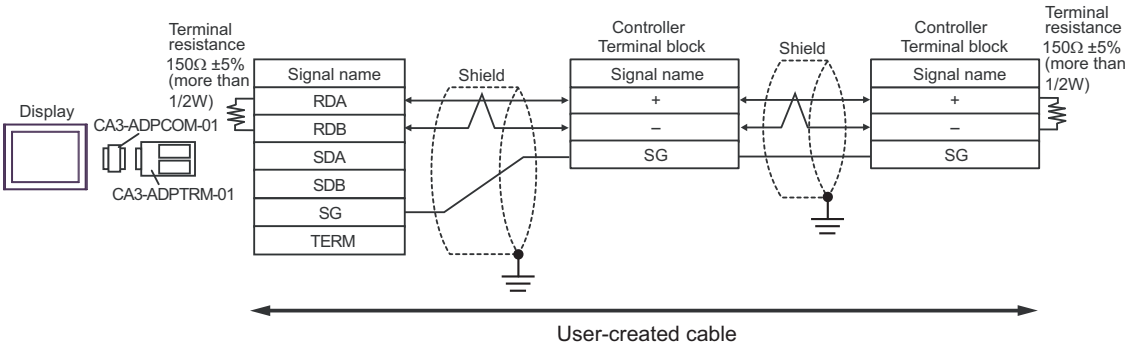

5F)

- 1:1 Connection

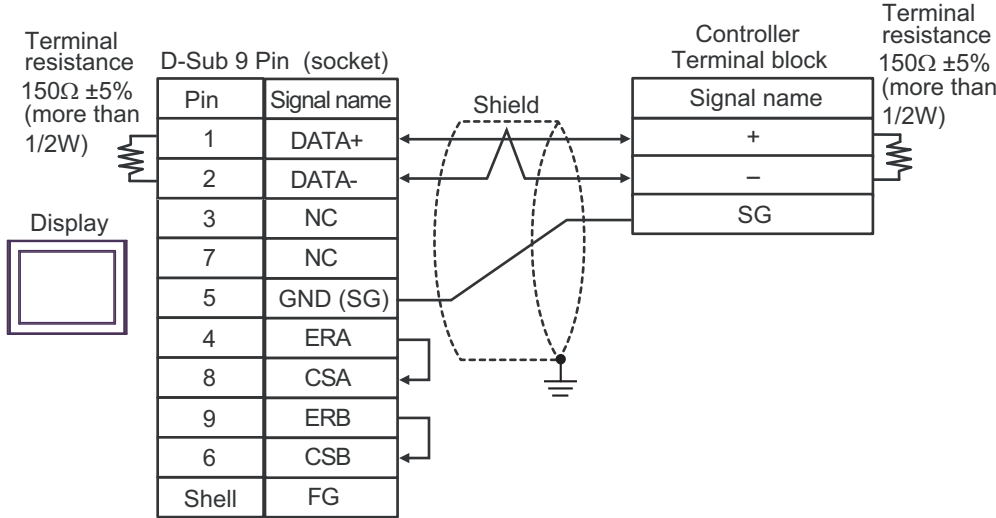

- 1:n Connection

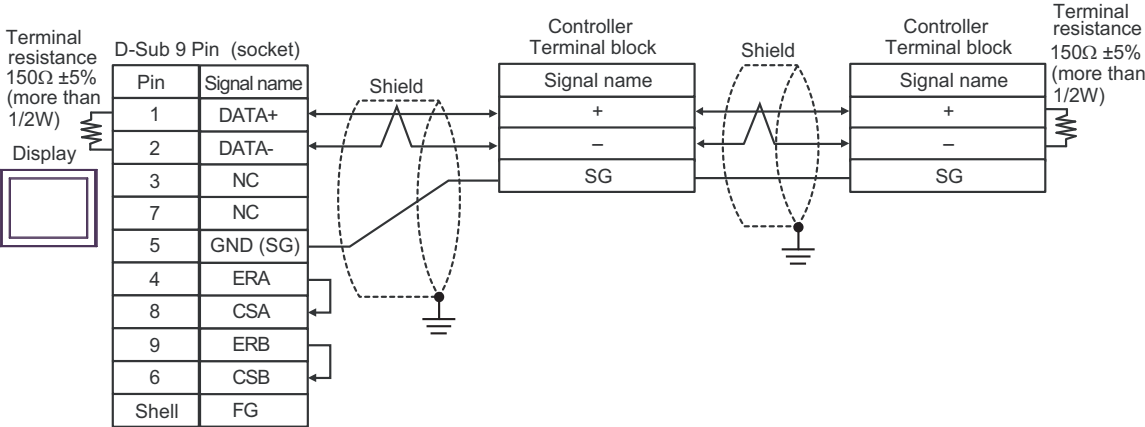

5G)

- 1:1 Connection

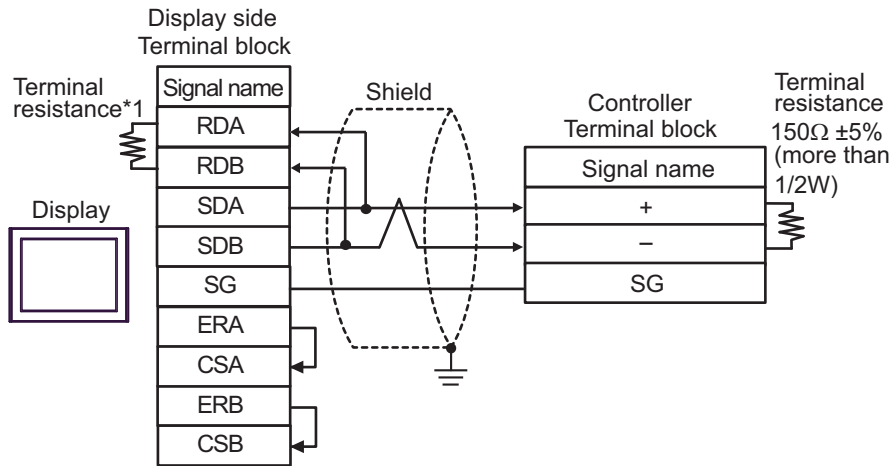

- 1:n Connection

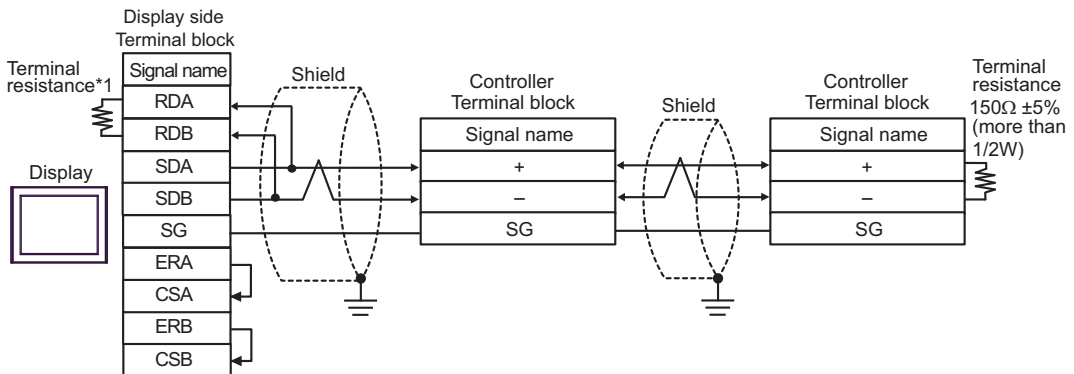

*1 The resistance in the Display is used as the termination resistance. Set the value of the DIP Switch on the rear of the Display as shown in the table below.

DIP Switch No.	Set Value
1	OFF
2	OFF
3	ON
4	ON

5H)

- 1:1 Connection

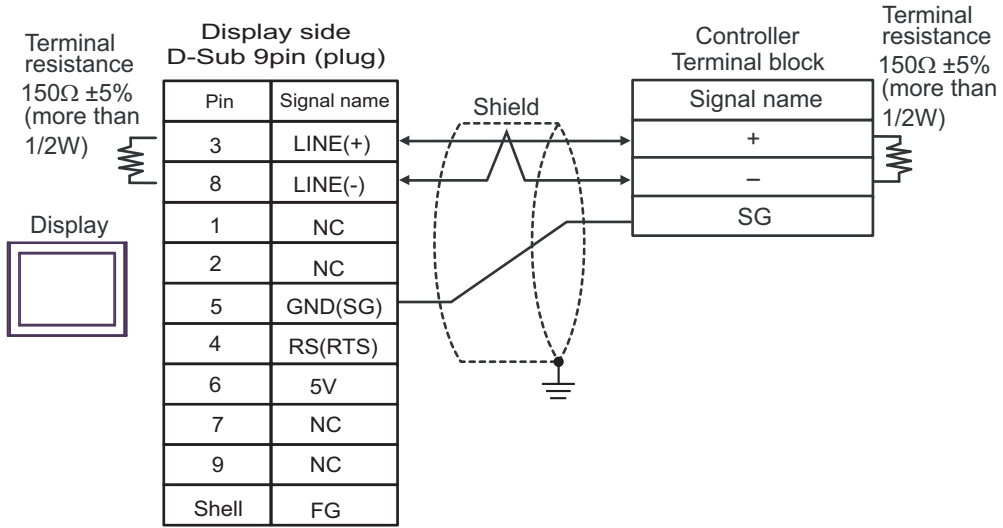

- 1:n Connection

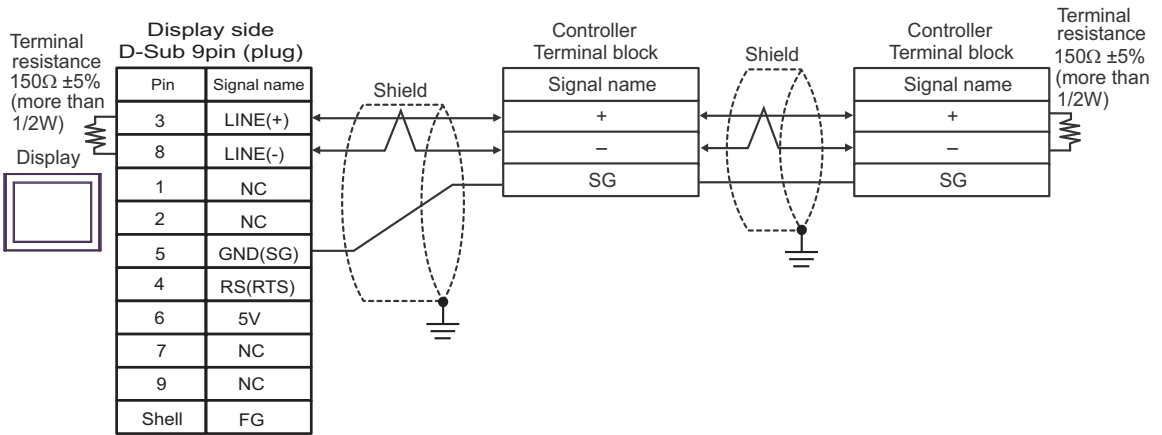

IMPORTANT • The 5V output (Pin #6) on the Display is the power for the Siemens AG's PROFIBUS connector. Do not use it for other devices.

NOTE • In COM on the GP-4107, the SG and FG terminals are isolated.

5I)

- 1:1 Connection

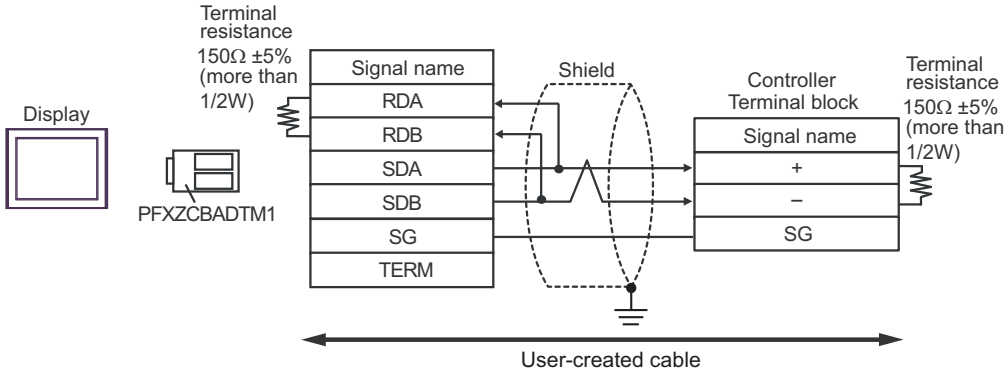

- 1:n Connection

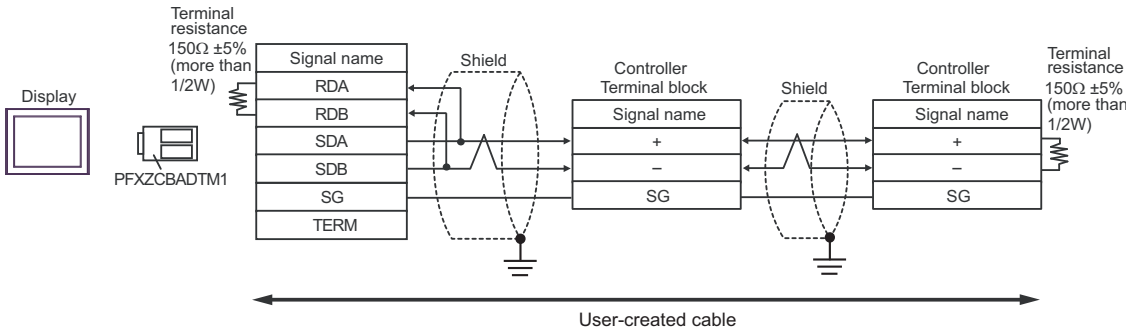

5J)

- 1:1 Connection

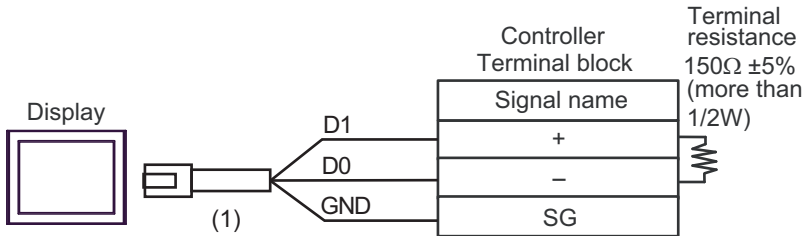

- 1:n Connection

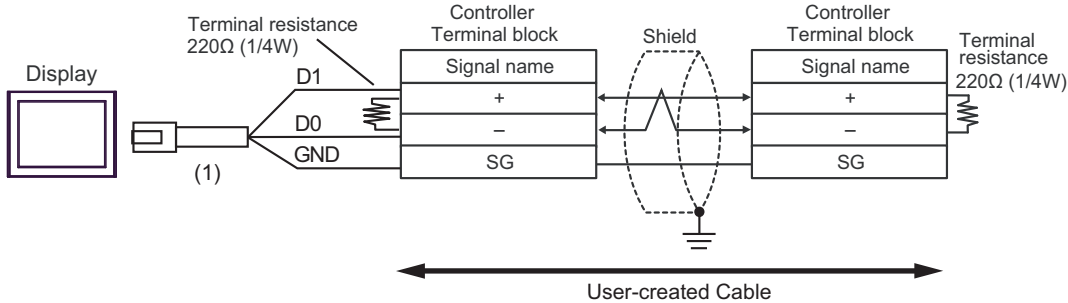

Number	Name	Notes
(1)	RJ45 RS-485 Cable (5m) by Pro-face PFXZLMCBRJR81	

5K)

- 1:1 Connection

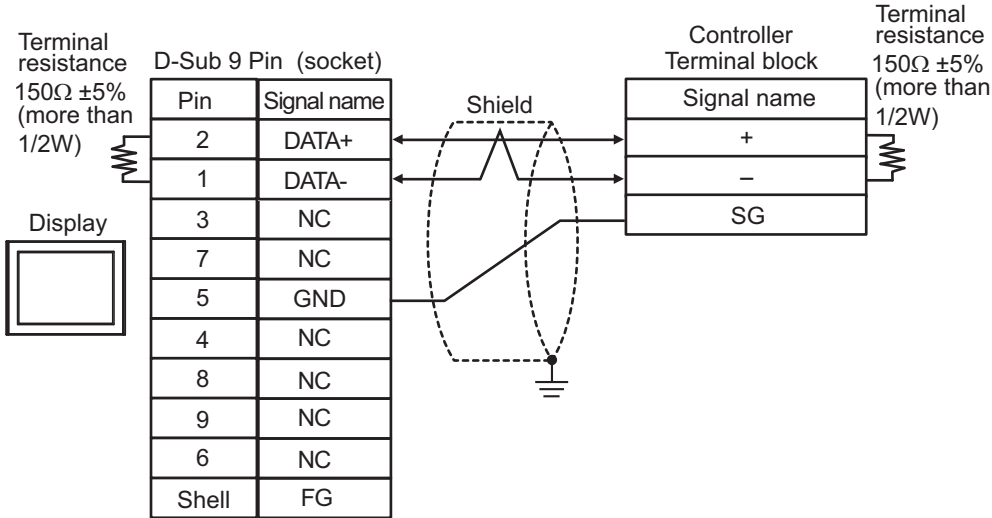

- 1:n Connection

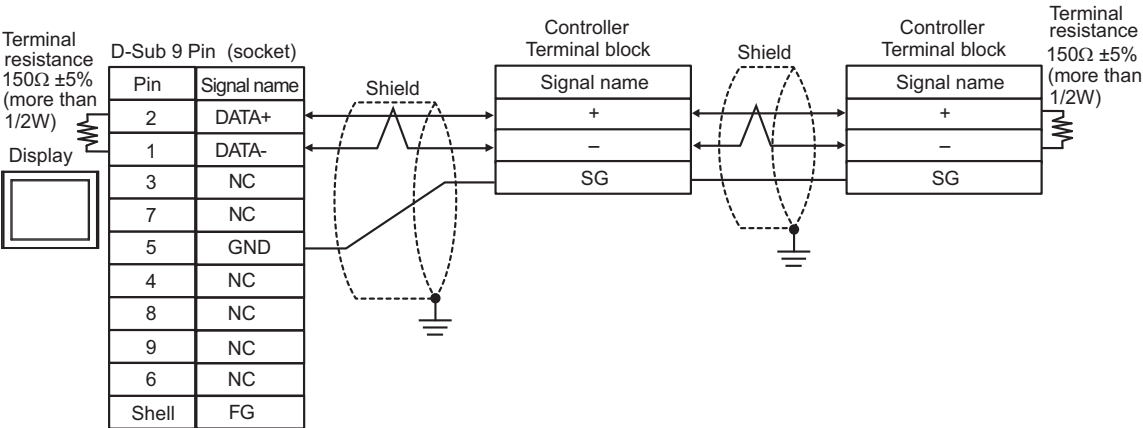

Cable Diagram 6

Display (Connection Port)	Cable		Remarks
GP3000* ¹ (COM1) AGP-3302B (COM2) GP-4*01TM (COM1) GP-Rear Module (COM1) ST3000* ² (COM2) LT3000 (COM1)	6A	COM port conversion adapter by Pro-face. CA3-ADPCOM-01 + Connector terminal block conversion adapter by Pro-face CA3-ADPTRM-01 + User-created cable	Cable length: 500m or less
	6B	User-created cable	
GP3000* ³ (COM2)	6C	Online adapter by Pro-face CA4-ADPONL-01 + Connector terminal block conversion adapter by Pro-face CA3-ADPTRM-01 + User-created cable	Cable length: 500m or less
	6D	Online adapter by Pro-face CA4-ADPONL-01 + User-created cable	
IPC* ⁴	6E	COM port conversion adapter by Pro-face. CA3-ADPCOM-01 + Connector terminal block conversion adapter by Pro-face CA3-ADPTRM-01 + User-created cable	Cable length: 500m or less
	6F	User-created cable	
GP-4106 (COM1) GP-4116T (COM1)	6G	User-created cable	Cable length: 500m or less
GP-4107 (COM1) GP-4*03T* ⁵ (COM2) GP-4203T (COM1)	6H	User-created cable	Cable length: 500m or less
GP4000* ⁶ (COM2) GP-4201T (COM1) SP5000* ⁷ (COM1/2) SP-5B00 (COM2) ST6000* ⁸ (COM2) ST-6200 (COM1) STM6000 (COM1) STC6000 (COM1) ET6000* ⁹ (COM2) PS6000 (Basic Box) (COM1/2)	6I	RS-422 terminal block conversion adapter by Pro-face PFXZCBADTM1* ¹⁰ + User-created cable	Cable length: 500m or less
	6B	User-created cable	
LT-4*01TM (COM1) LT-Rear Module (COM1)	6J	RJ45 RS-485 Cable (5m) by Pro-face PFXZLMCBJR81	Cable length: 200m or less
PE-4000B* ¹¹ PS5000* ¹¹ PS6000 (Optional Interface)* ¹¹	6K	User-created cable	Cable length: 500m or less

*1 All GP3000 models except AGP-3302B

- *2 Except AST-3211A and AST-3302B
- *3 All GP3000 models except the GP-3200 Series and AGP-3302B
- *4 Available only with COM ports that support RS-422/485 (2wire). (Except PE-4000B, PS5000, and PS6000)
 ☞ ■ IPC COM Port (page 9)
- *5 Except GP-4203T
- *6 All GP4000 models except GP-4100 series, GP-4*01TM, GP-Rear Module, GP-4201T and GP-4*03T
- *7 Except SP-5B00
- *8 Except ST-6200
- *9 Due to the COM port specifications, flow control is not possible. Omit wiring the control pins on the Display side of the cable diagram.
- *10 When using a Terminal Block Conversion Adapter (CA3-ADPTRM-01) instead of the RS-422 Terminal Block Conversion Adapter, refer to Cable Diagram 6A.
- *11 Available only with COM ports that support RS-422/485 (2wire).
 ☞ ■ IPC COM Port (page 9)

6A)

- 1:1 Connection

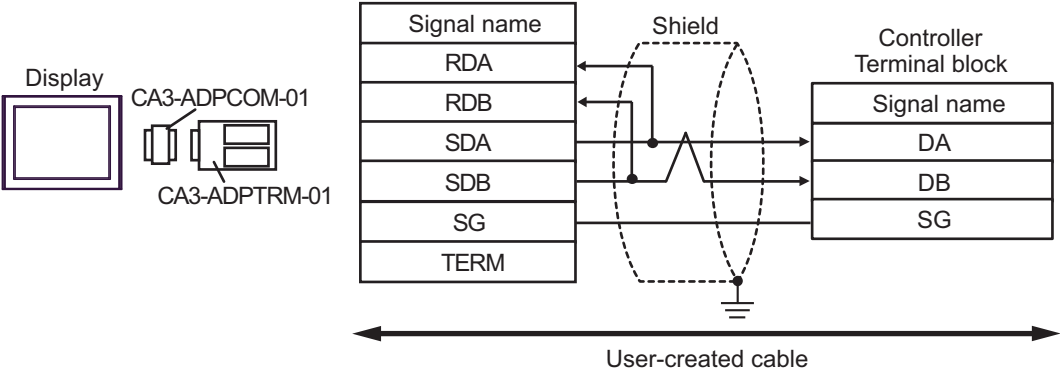

NOTE • No termination resistor is required.

- 1:n Connection

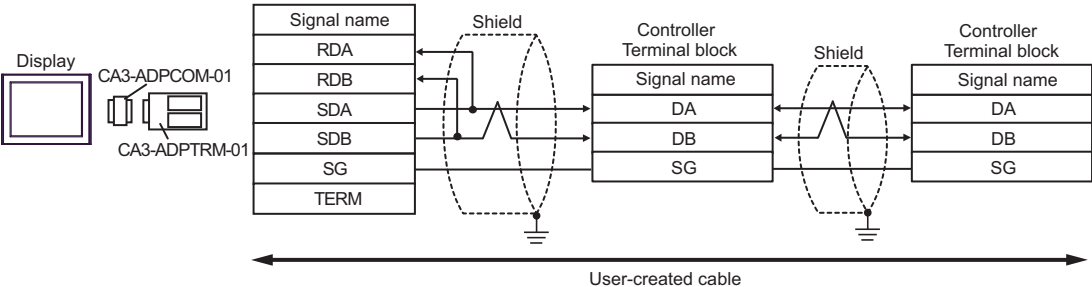

NOTE • No termination resistor is required.

6B)

- 1:1 Connection

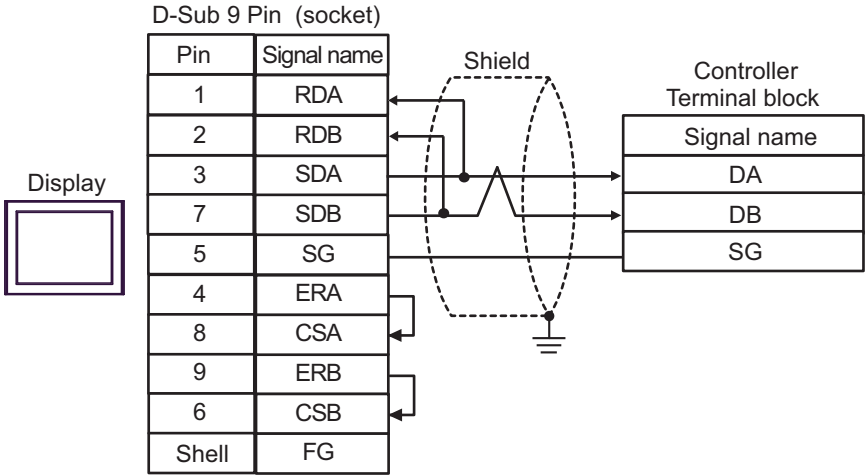

NOTE • No termination resistor is required.

- 1:n Connection

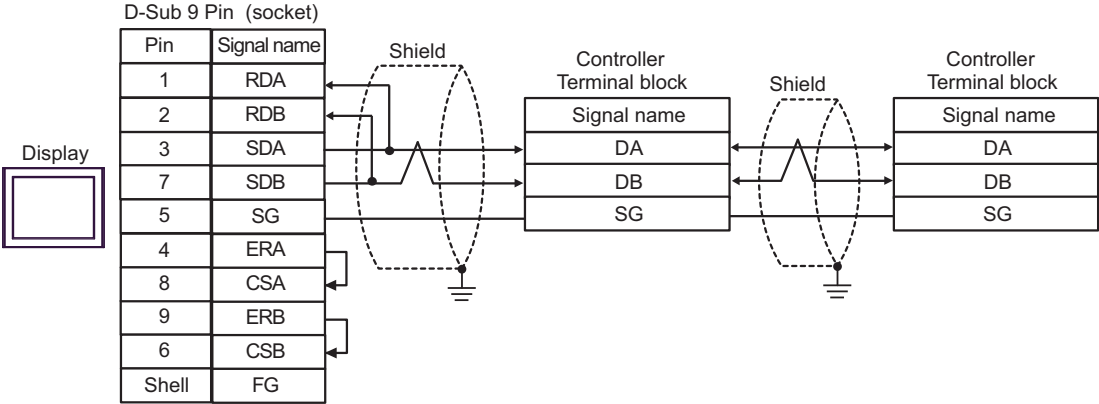

NOTE • No termination resistor is required.

6C)

- 1:1 Connection

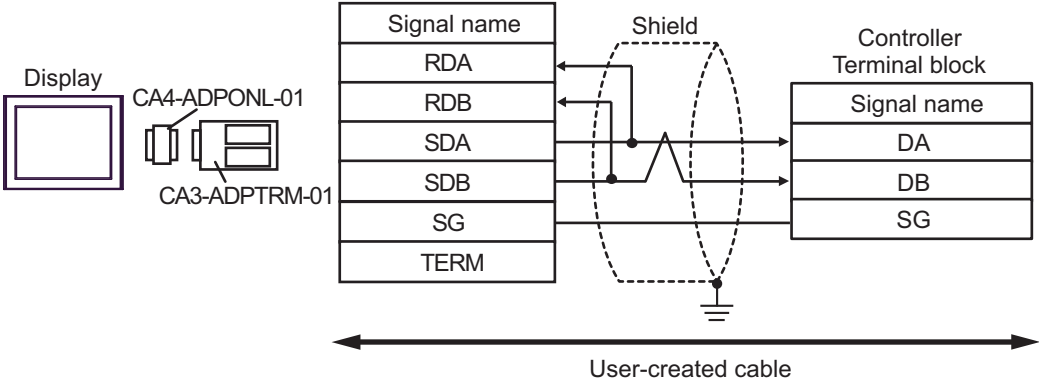

NOTE • No termination resistor is required.

- 1:n Connection

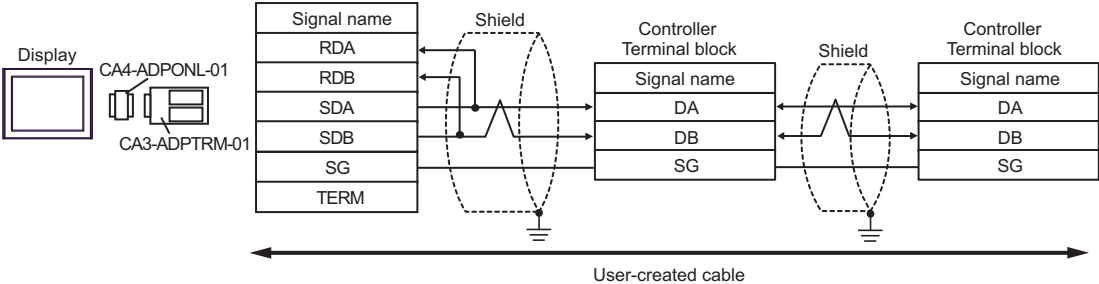

NOTE • No termination resistor is required.

6D)

- 1:1 Connection

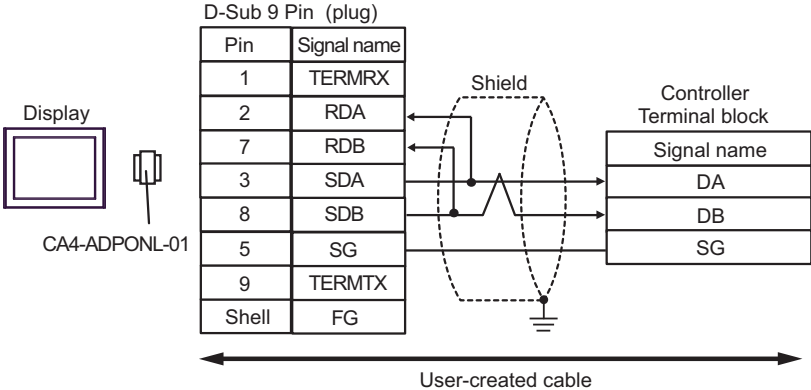

NOTE • No termination resistor is required.

- 1:n Connection

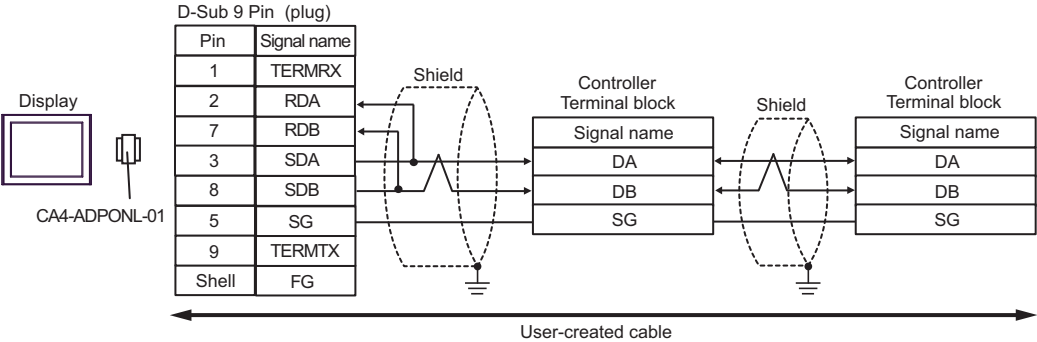

NOTE • No termination resistor is required.

6E)

- 1:1 Connection

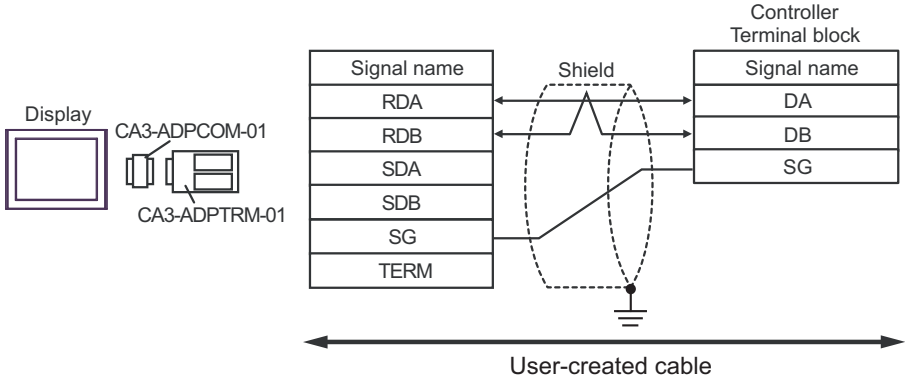

NOTE • No termination resistor is required.

- 1:n Connection

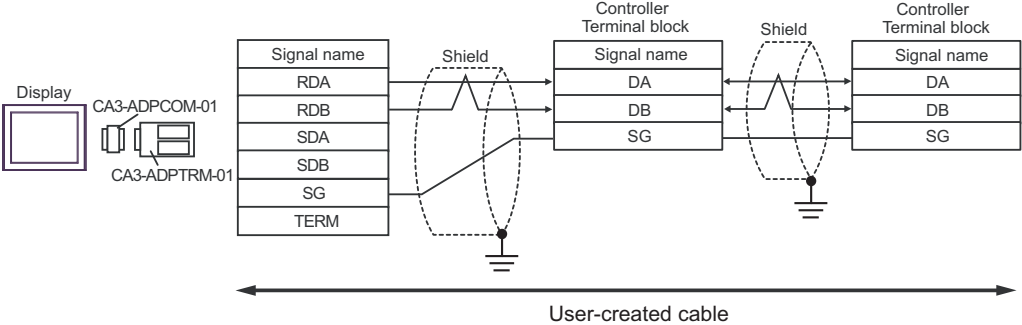

NOTE • No termination resistor is required.

6F)

- 1:1 Connection

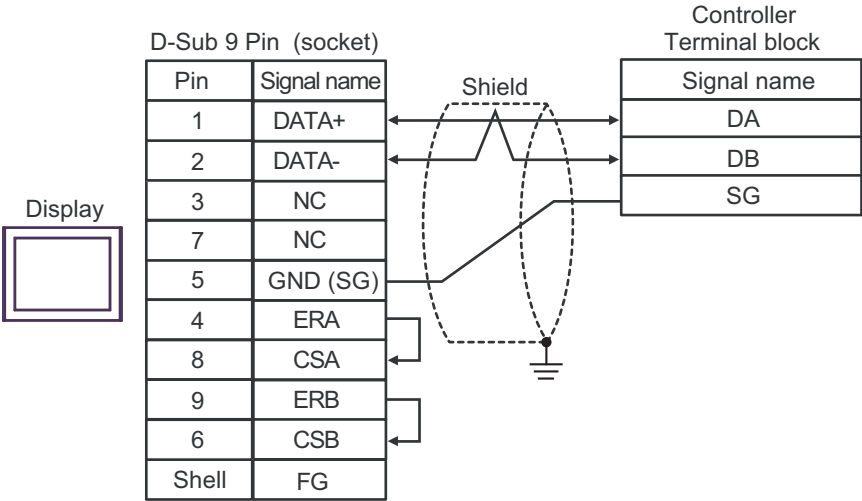

NOTE • No termination resistor is required.

- 1:n Connection

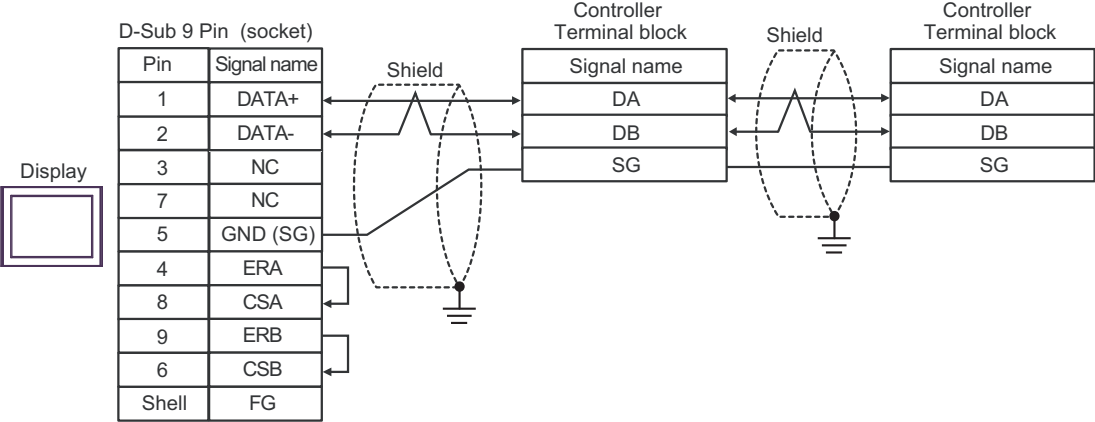

NOTE • No termination resistor is required.

6G)

- 1:1 Connection

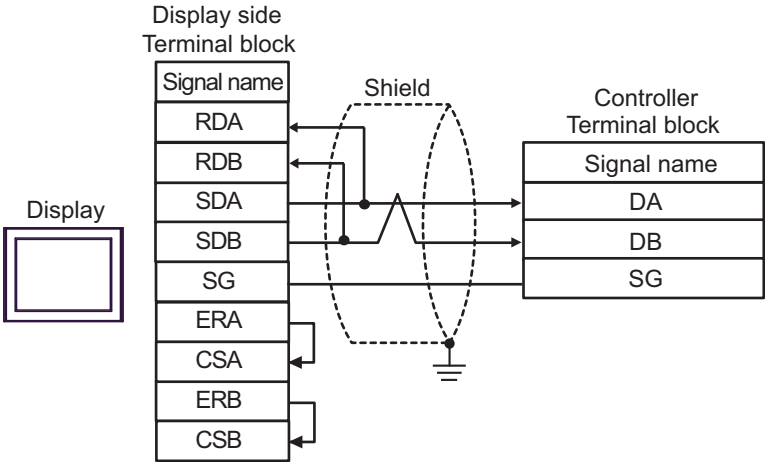

NOTE • No termination resistor is required.

- 1:n Connection

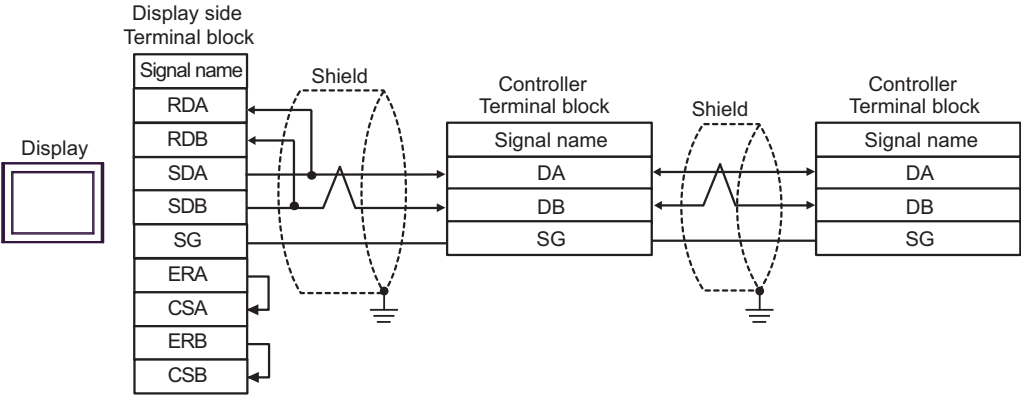

NOTE • No termination resistor is required.

6H)

- 1:1 Connection

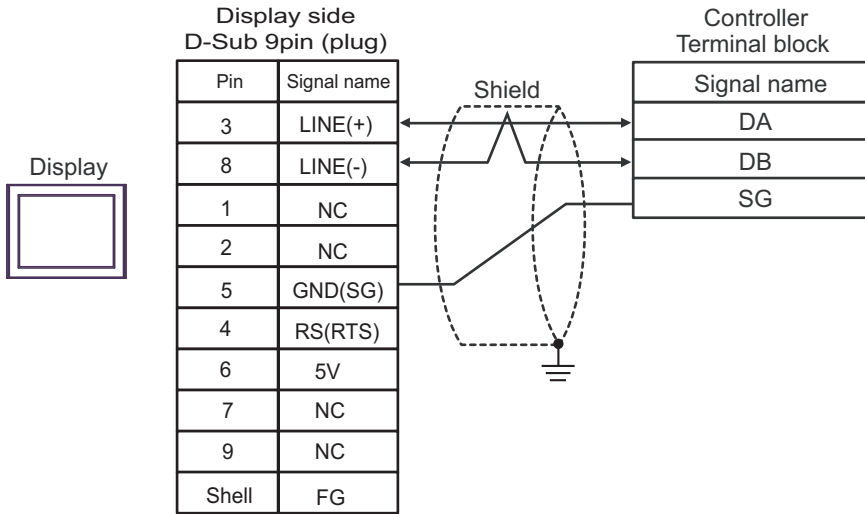

NOTE • No termination resistor is required.

- 1:n Connection

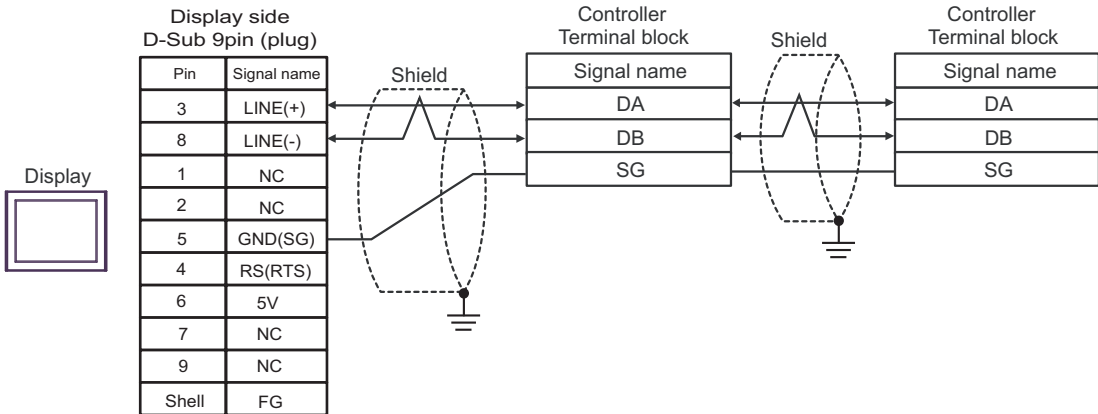

IMPORTANT • The 5V output (Pin #6) on the Display is the power for the Siemens AG's PROFIBUS connector. Do not use it for other devices.

NOTE • No termination resistor is required.
 • In COM on the GP-4107, the SG and FG terminals are isolated.

- 6I)
- 1:1 Connection

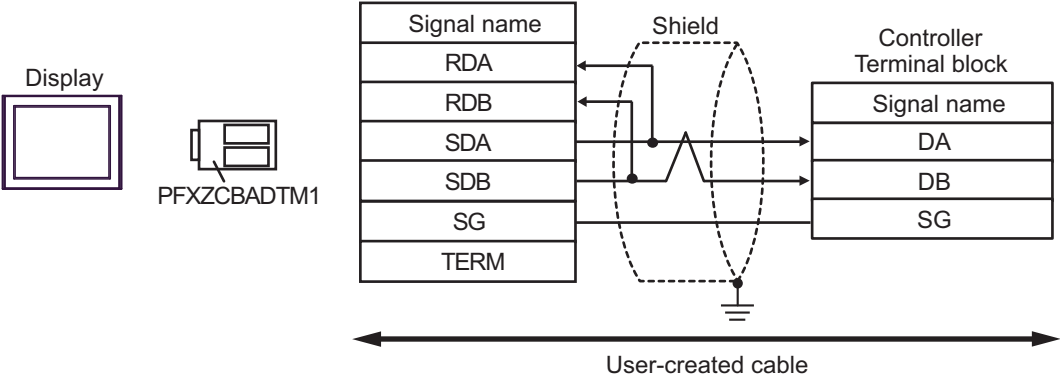

NOTE • No termination resistor is required.

- 1:n Connection

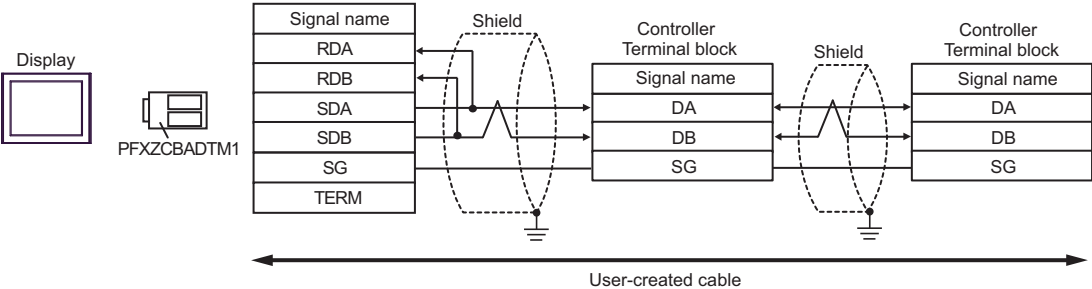

NOTE • No termination resistor is required.

6J)

- 1:1 Connection

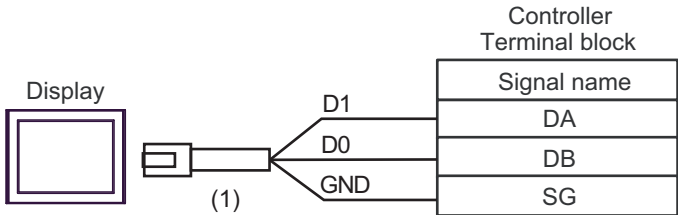

NOTE • No termination resistor is required.

- 1:n Connection

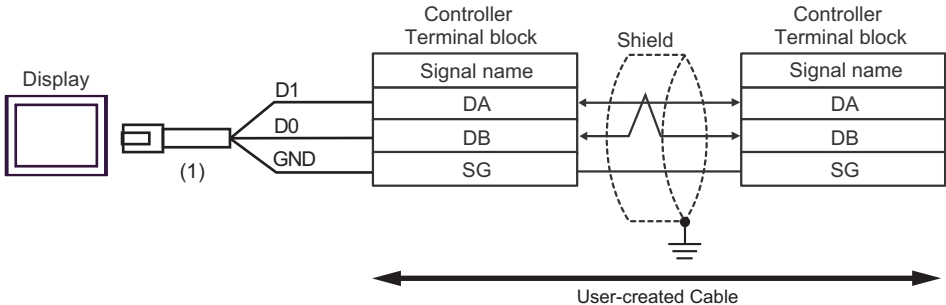

NOTE • No termination resistor is required.

Number	Name	Notes
(1)	RJ45 RS-485 Cable (5m) by Pro-face PFXZLMCBJR81	

6K)

- 1:1 Connection

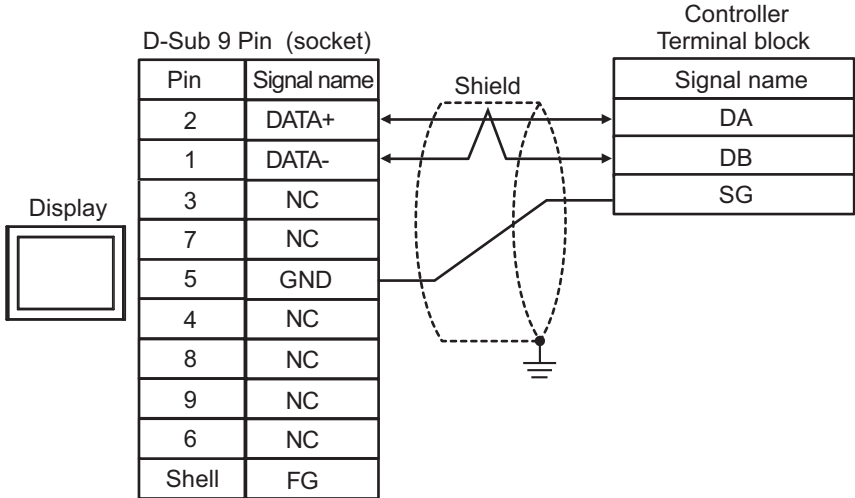

NOTE • No termination resistor is required.

- 1:n Connection

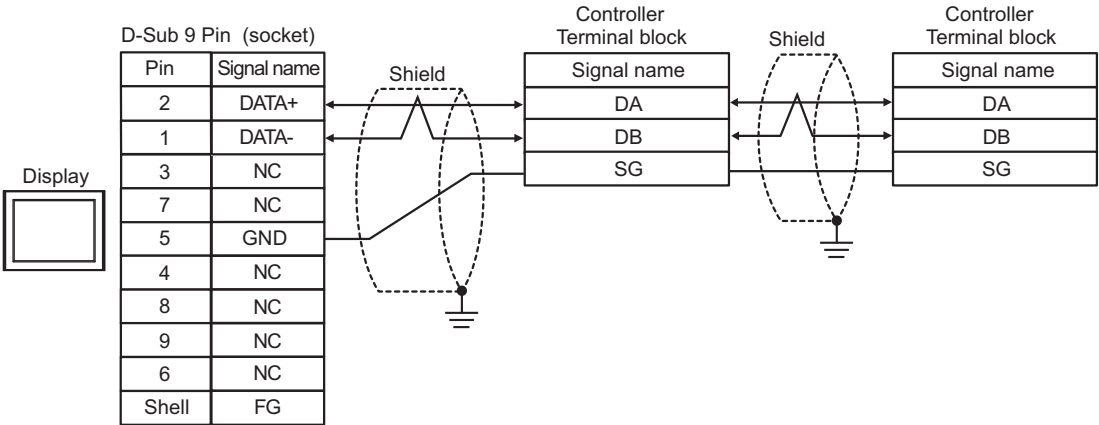

NOTE • No termination resistor is required.

Cable Diagram 7

Display (Connection Port)	Cable		Remarks
GP3000 ^{*1} (COM1) AGP-3302B (COM2) GP-4*01TM (COM1) GP-Rear Module (COM1) ST3000 ^{*2} (COM2) LT3000 (COM1) IPC ^{*3}	7A	COM port conversion adapter by Pro-face. CA3-ADPCOM-01 + Connector terminal block conversion adapter by Pro-face CA3-ADPTRM-01 + User-created cable	Cable length: 500m or less
	7B	User-created cable	
GP3000 ^{*4} (COM2)	7C	Online adapter by Pro-face CA4-ADPONL-01 + Connector terminal block conversion adapter by Pro-face CA3-ADPTRM-01 + User-created cable	Cable length: 500m or less
	7D	Online adapter by Pro-face CA4-ADPONL-01 + User-created cable	
GP-4106 (COM1) GP-4116T (COM1)	7E	User-created cable	Cable length: 500m or less
GP4000 ^{*5} (COM2) GP-4201T (COM1) SP5000 ^{*6} (COM1/2) SP-5B00 (COM2) ST6000 ^{*7} (COM2) ST-6200 (COM1) STM6000 (COM1) STC6000 (COM1) ET6000 ^{*8} (COM2) PS6000 (Basic Box) (COM1/2)	7F	RS-422 terminal block conversion adapter by Pro-face PFXZCBADTM1 ^{*9} + User-created cable	Cable length: 500m or less
	7B	User-created cable	
PE-4000B ^{*10} PS5000 ^{*10} PS6000 (Optional Interface) ^{*10}	7G	User-created cable	Cable length: 500m or less

*1 All GP3000 models except AGP-3302B

*2 Except AST-3211A and AST-3302B

*3 Available only with COM ports that support RS-422/485 (4wire). (Except PE-4000B, PS5000, and PS6000)
 ■ IPC COM Port (page 9)

*4 All GP3000 models except the GP-3200 Series and AGP-3302B

*5 All GP4000 models except GP-4100 series, GP-4*01TM, GP-Rear Module, GP-4201T and GP-4*03T

*6 Except SP-5B00

*7 Except ST-6200

*8 Due to the COM port specifications, flow control is not possible. Omit wiring the control pins on the Display side of the cable diagram.

- *9 When using a Terminal Block Conversion Adapter (CA3-ADPTRM-01) instead of the RS-422 Terminal Block Conversion Adapter, refer to Cable Diagram 7A.
- *10 Available only with COM ports that support RS-422/485 (4wire).
 - ☞ ■ IPC COM Port (page 9)

7A

- 1:1 Connection

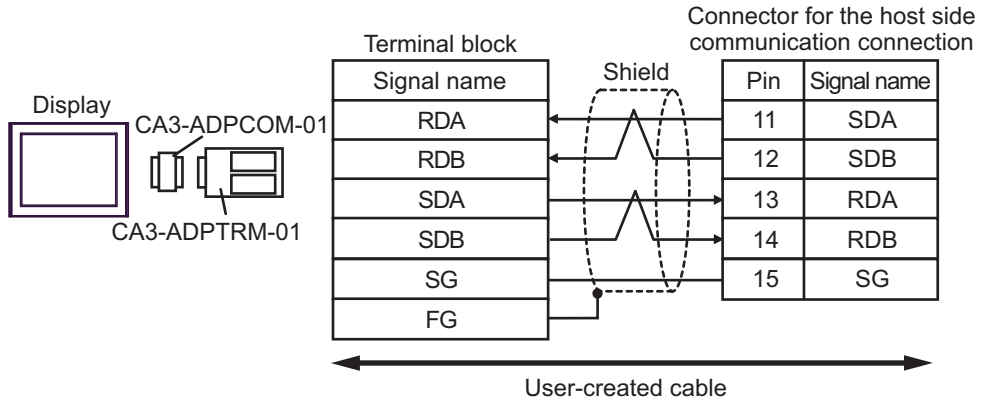

- 1:n Connection

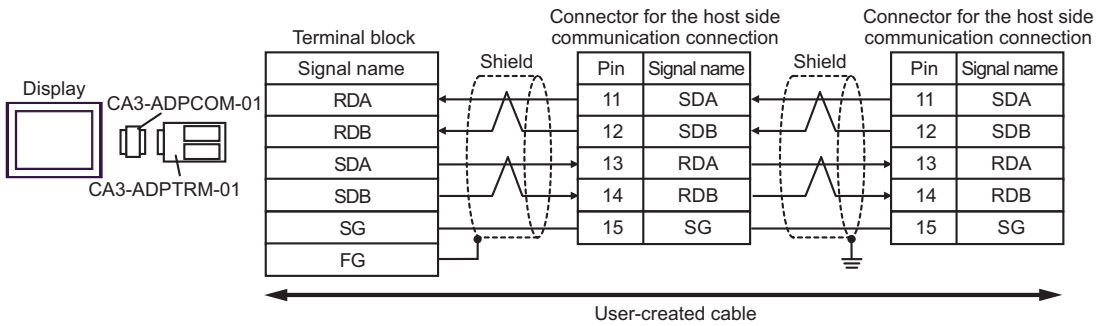

7B)

- 1:1 Connection

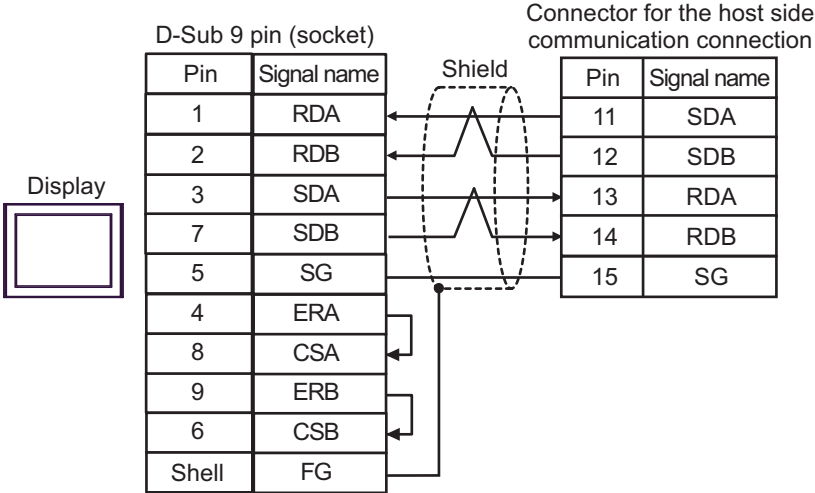

- 1:n Connection

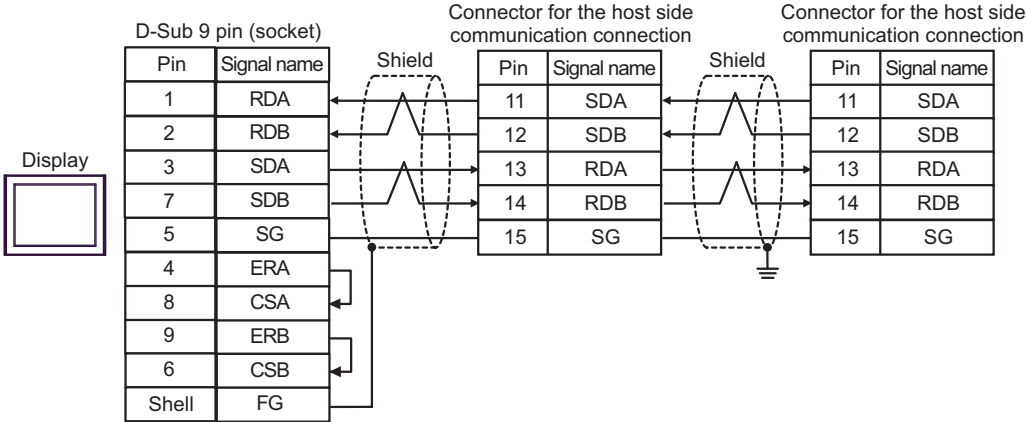

7C)

- 1:1 Connection

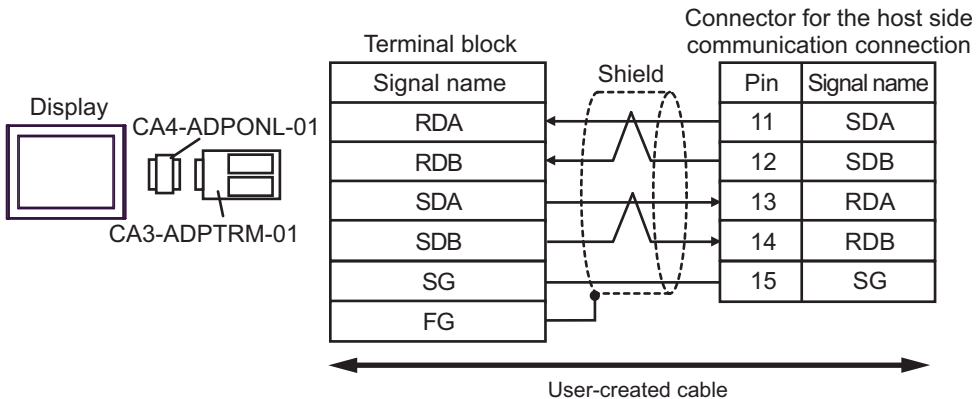

- 1:n Connection

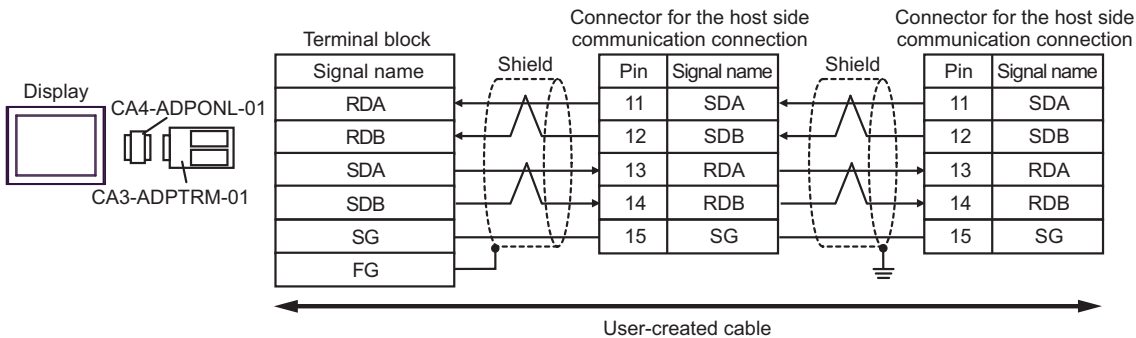

7D)

- 1:1 Connection

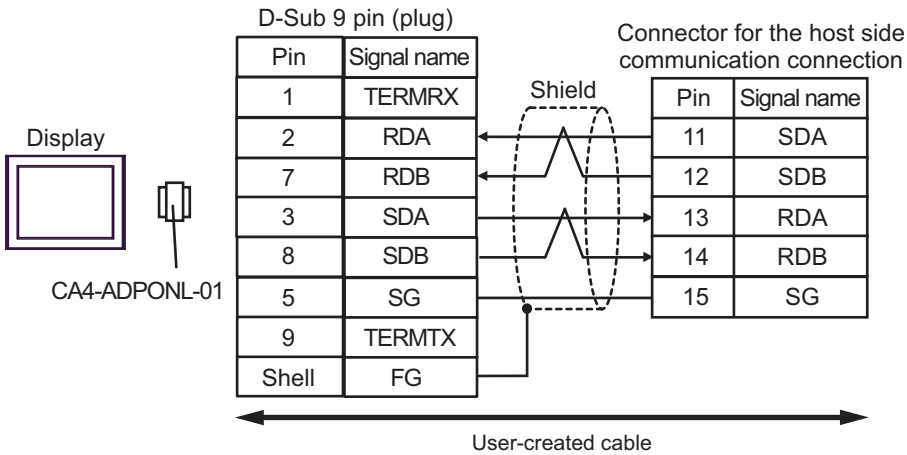

- 1:n Connection

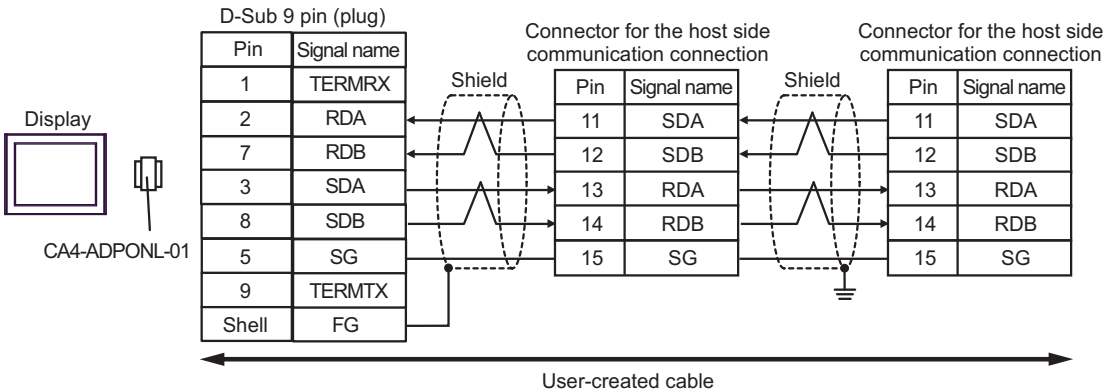

7E)

- 1:1 Connection

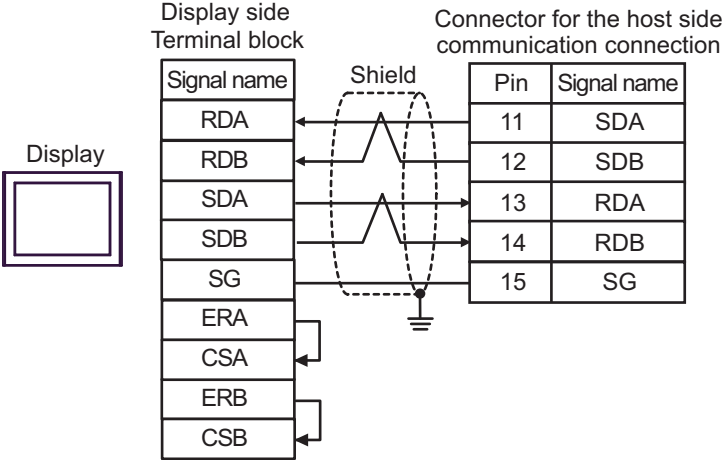

- 1:n Connection

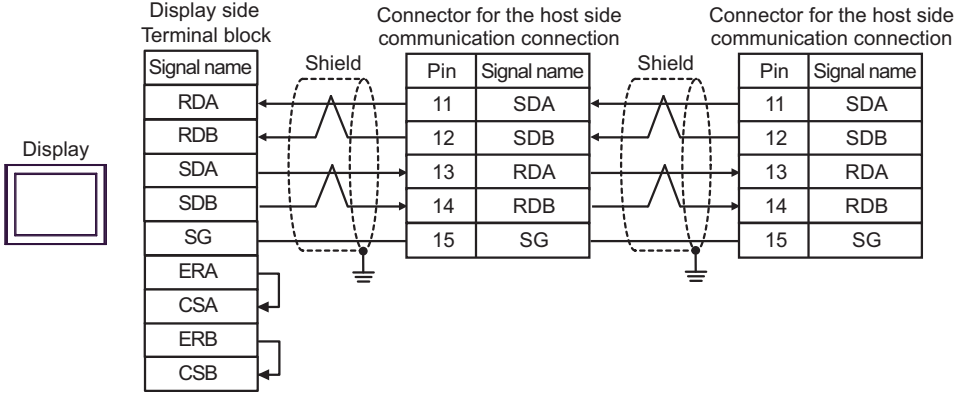

7F

- 1:1 Connection

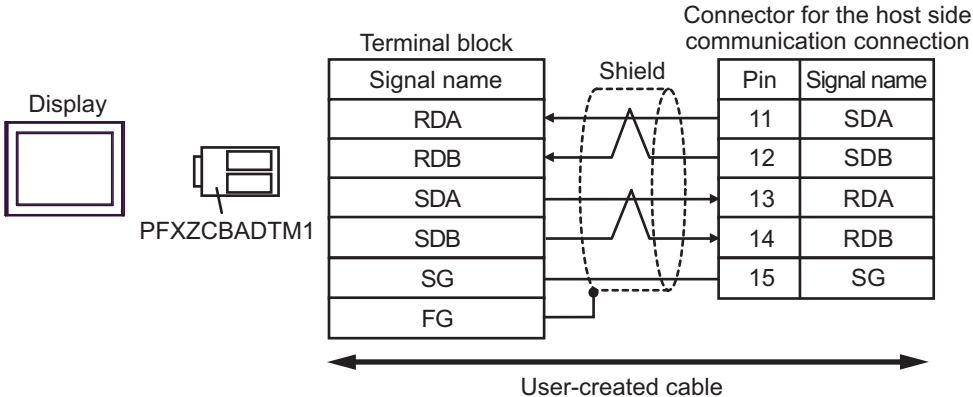

- 1:n Connection

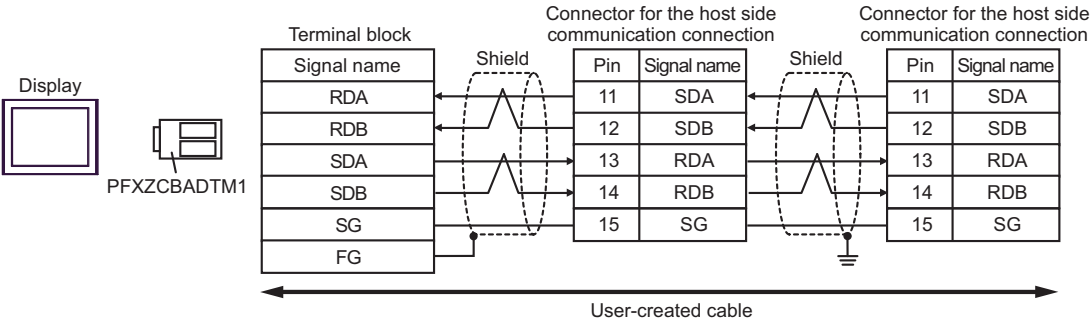

7G)

- 1:1 Connection

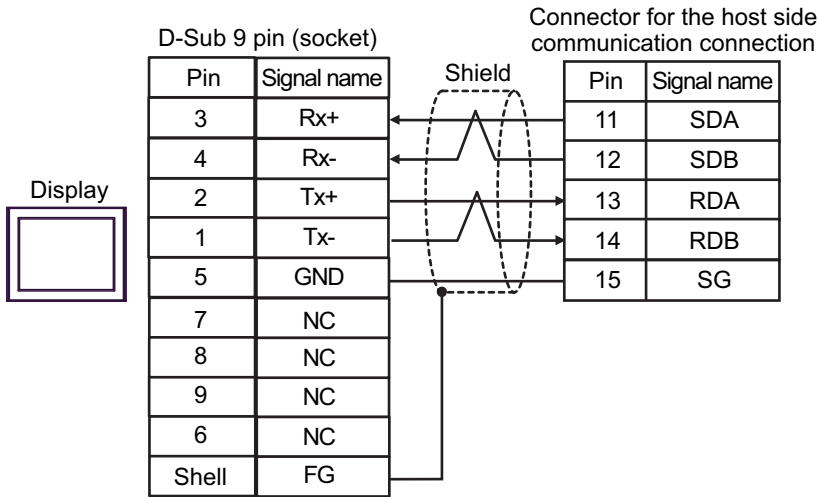

- 1:n Connection

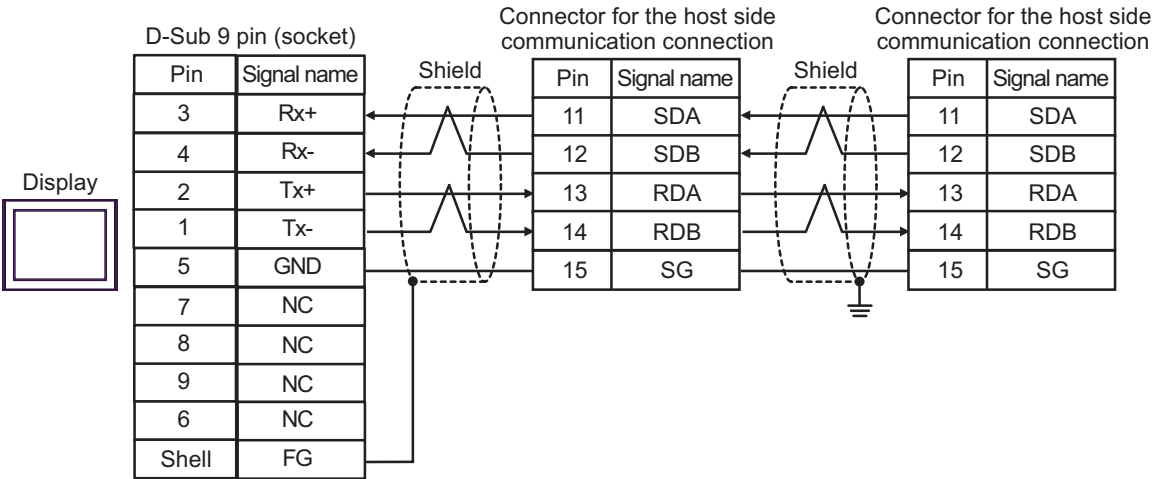

Cable Diagram 8

Display (Connection Port)	Cable		Remarks
GP3000* ¹ (COM1) AGP-3302B (COM2) GP-4*01TM (COM1) GP-Rear Module (COM1) ST3000* ² (COM2) LT3000 (COM1)	8A	COM port conversion adapter by Pro-face. CA3-ADPCOM-01 + Connector terminal block conversion adapter by Pro-face CA3-ADPTRM-01 + User-created cable	Cable length: 500m or less
	8B	User-created cable	
GP3000* ³ (COM2)	8C	Online adapter by Pro-face CA4-ADPONL-01 + Connector terminal block conversion adapter by Pro-face CA3-ADPTRM-01 + User-created cable	Cable length: 500m or less
	8D	Online adapter by Pro-face CA4-ADPONL-01 + User-created cable	
IPC* ⁴	8E	COM port conversion adapter by Pro-face. CA3-ADPCOM-01 + Connector terminal block conversion adapter by Pro-face CA3-ADPTRM-01 + User-created cable	Cable length: 500m or less
	8F	User-created cable	
GP-4106 (COM1) GP-4116T (COM1)	8G	User-created cable	Cable length: 500m or less
GP-4107 (COM1) GP-4*03T* ⁵ (COM2) GP-4203T (COM1)	8H	User-created cable	Cable length: 500m or less
GP4000* ⁶ (COM2) GP-4201T (COM1) SP5000* ⁷ (COM1/2) SP-5B00 (COM2) ST6000* ⁸ (COM2) ST-6200 (COM1) STM6000 (COM1) STC6000 (COM1) ET6000* ⁹ (COM2) PS6000 (Basic Box) (COM1/2)	8I	RS-422 terminal block conversion adapter by Pro-face PFXZCBADTM1* ¹⁰ + User-created cable	Cable length: 500m or less
	8B	User-created cable	
LT-4*01TM (COM1) LT-Rear Module (COM1)	8J	RJ45 RS-485 Cable (5m) by Pro-face PFXZLMCBJR81	Cable length: 200m or less
PE-4000B* ¹¹ PS5000* ¹¹ PS6000 (Optional Interface)* ¹¹	8K	User-created cable	Cable length: 500m or less

*1 All GP3000 models except AGP-3302B

- *2 Except AST-3211A and AST-3302B
- *3 All GP3000 models except the GP-3200 Series and AGP-3302B
- *4 Available only with COM ports that support RS-422/485 (2wire). (Except PE-4000B, PS5000, and PS6000)
 ☞ ■ IPC COM Port (page 9)
- *5 Except GP-4203T
- *6 All GP4000 models except GP-4100 series, GP-4*01TM, GP-Rear Module, GP-4201T and GP-4*03T
- *7 Except SP-5B00
- *8 Except ST-6200
- *9 Due to the COM port specifications, flow control is not possible. Omit wiring the control pins on the Display side of the cable diagram.
- *10 When using a Terminal Block Conversion Adapter (CA3-ADPTRM-01) instead of the RS-422 Terminal Block Conversion Adapter, refer to Cable Diagram 8A.
- *11 Available only with COM ports that support RS-422/485 (2wire).
 ☞ ■ IPC COM Port (page 9)

8A)

- 1:1 Connection

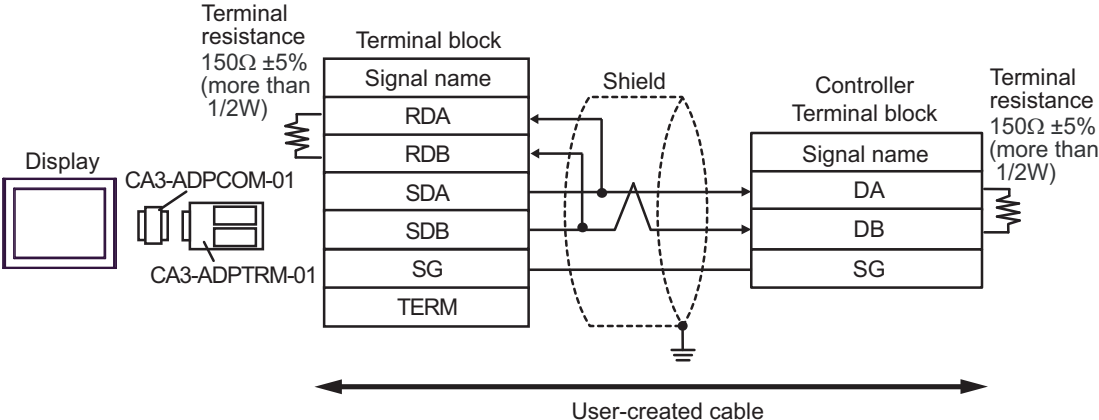

- 1:n Connection

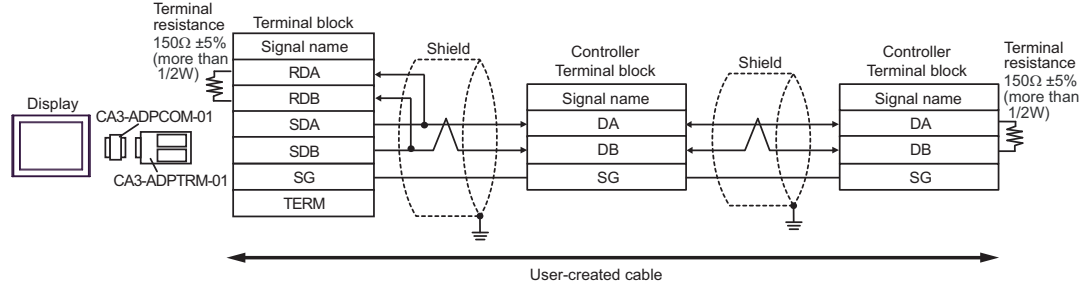

8B

- 1:1 Connection

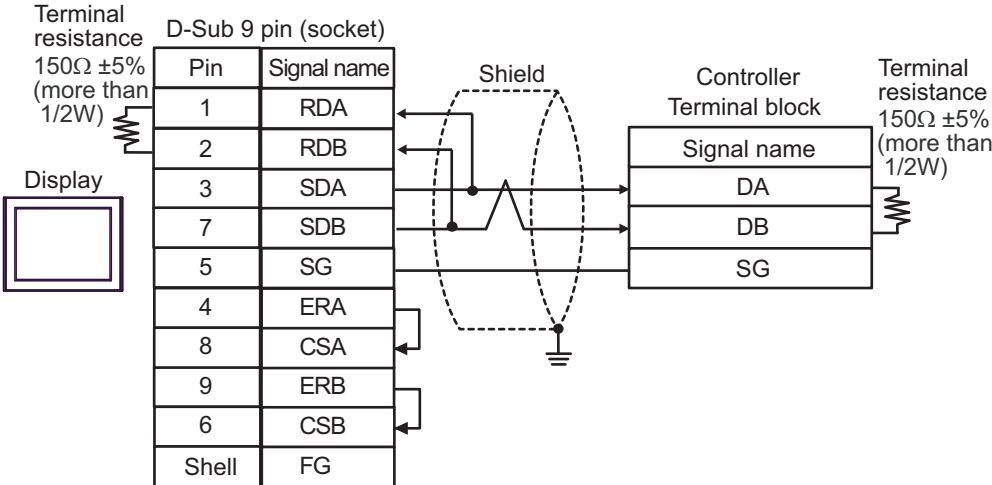

- 1:n Connection

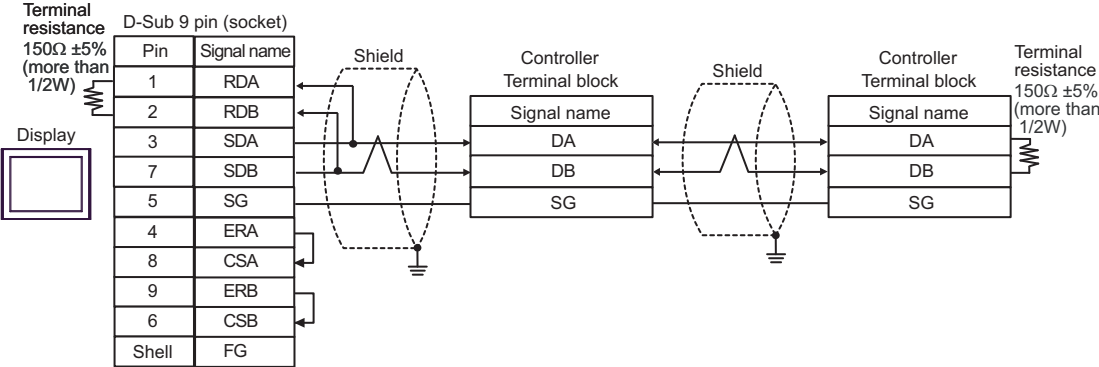

8C)

- 1:1 Connection

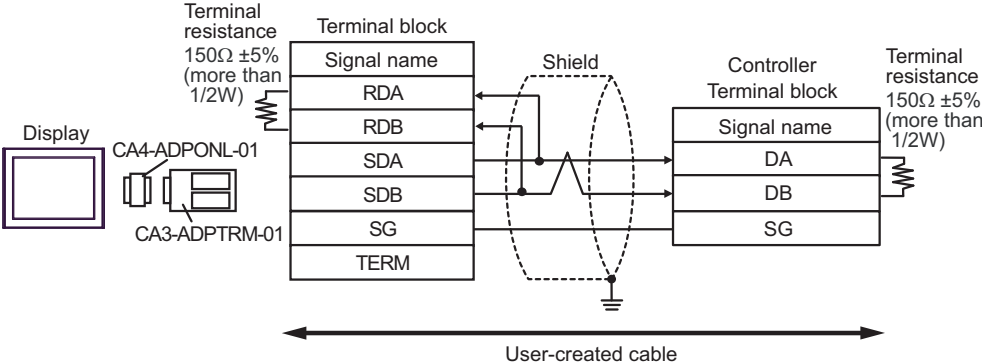

- 1:n Connection

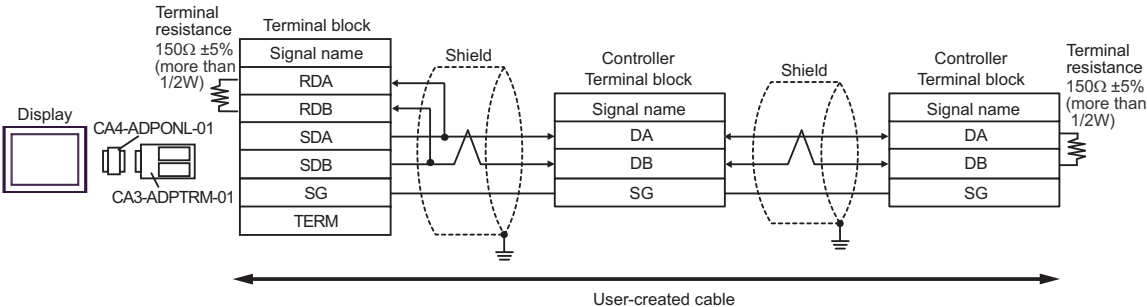

8D)

- 1:1 Connection

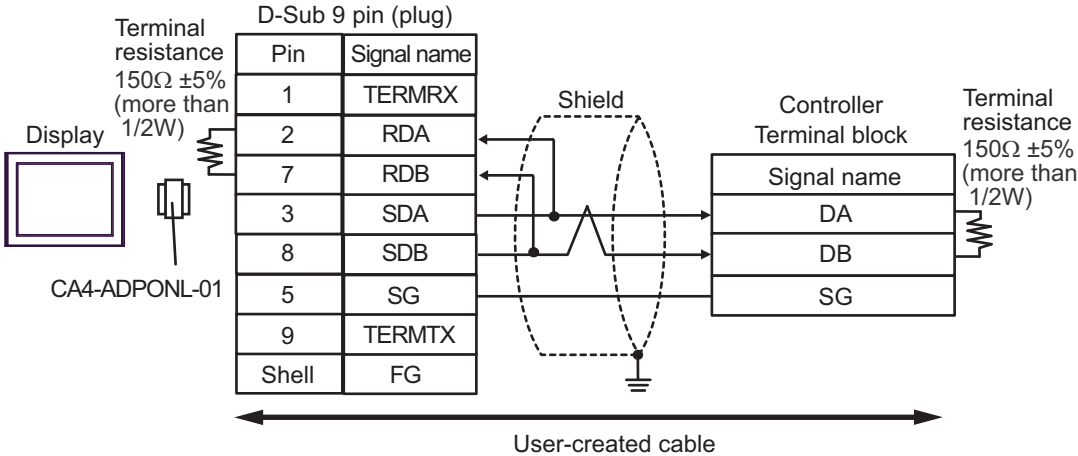

- 1:n Connection

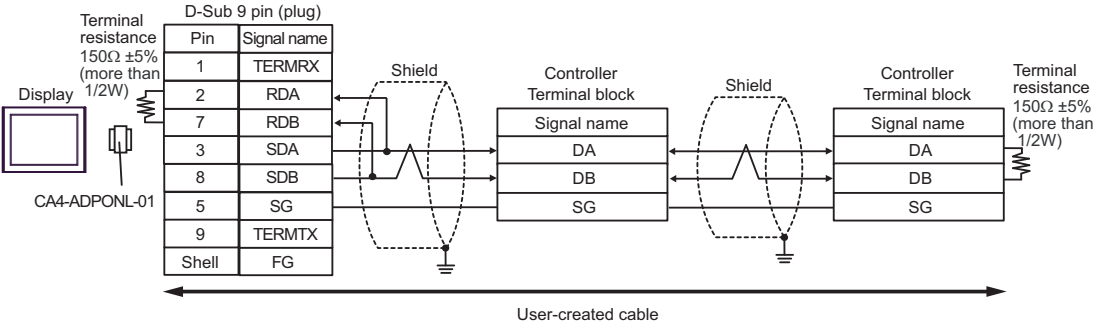

8E)

- 1:1 Connection

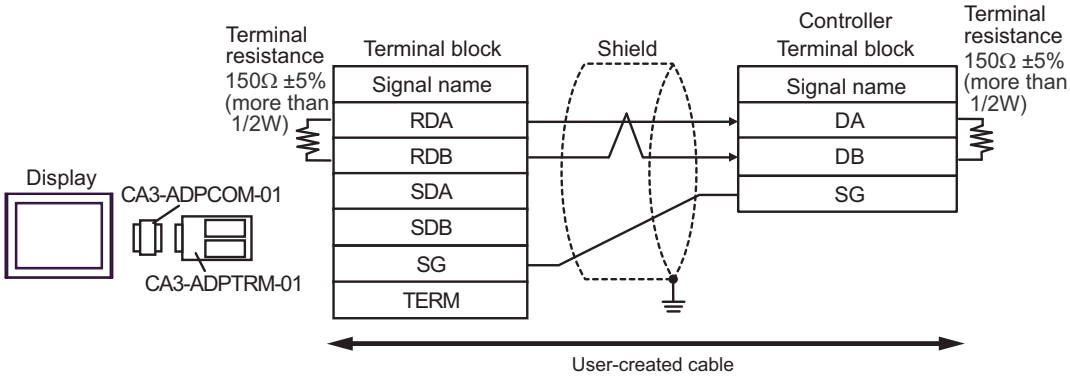

- 1:n Connection

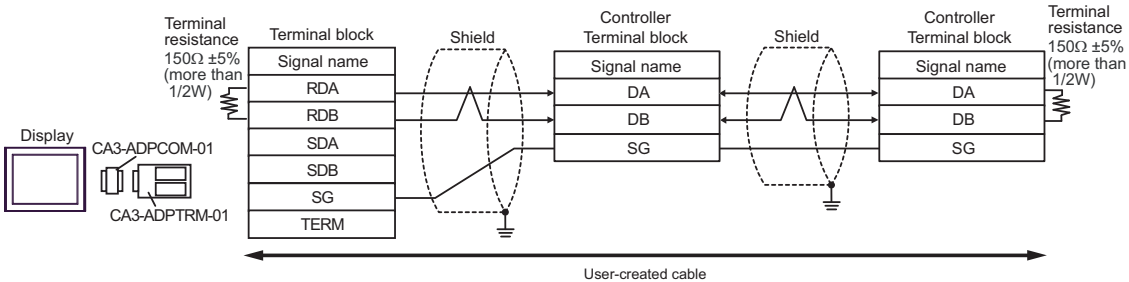

8F)

- 1:1 Connection

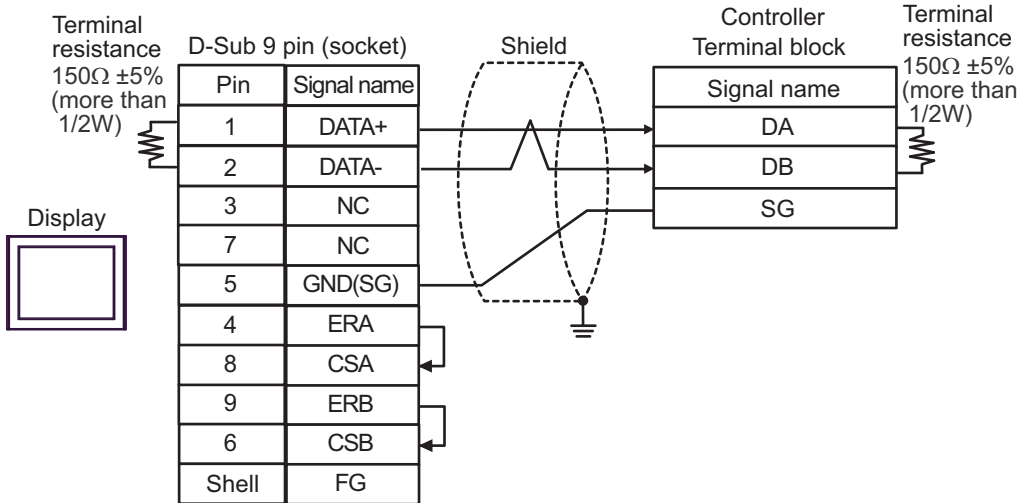

- 1:n Connection

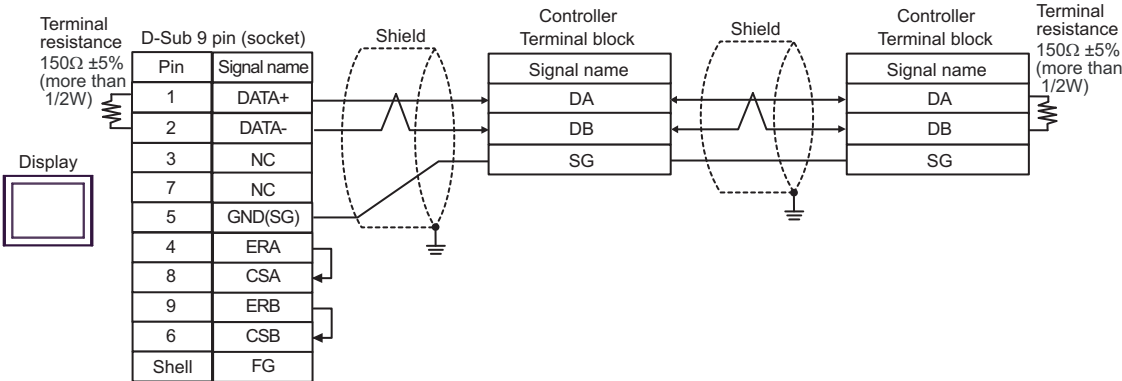

8G)

- 1:1 Connection

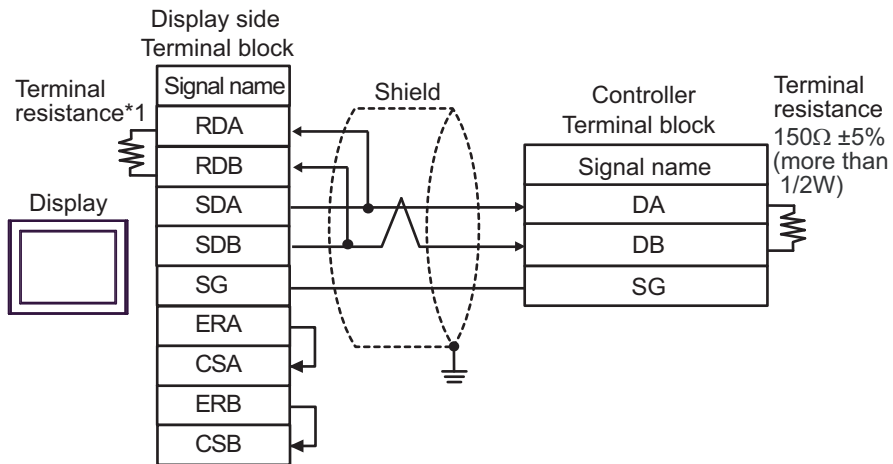

- 1:n Connection

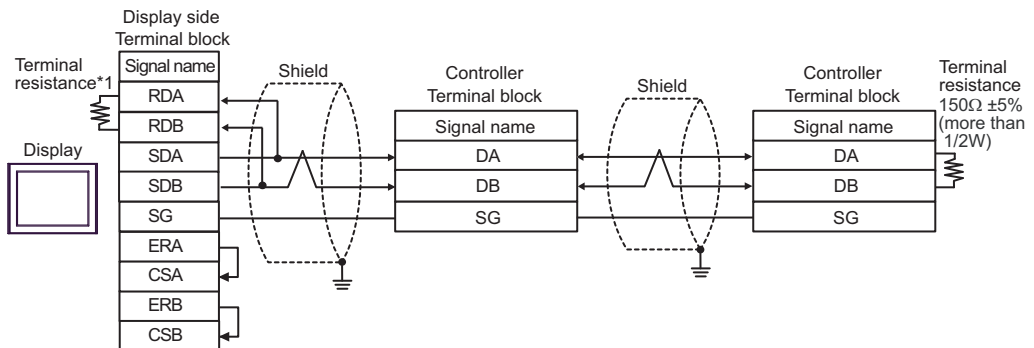

- *1 The resistance in the Display is used as the termination resistance. Set the value of the DIP Switch on the rear of the Display as shown in the table below.

DIP Switch No.	Set Value
1	OFF
2	OFF
3	ON
4	ON

8H)

- 1:1 Connection

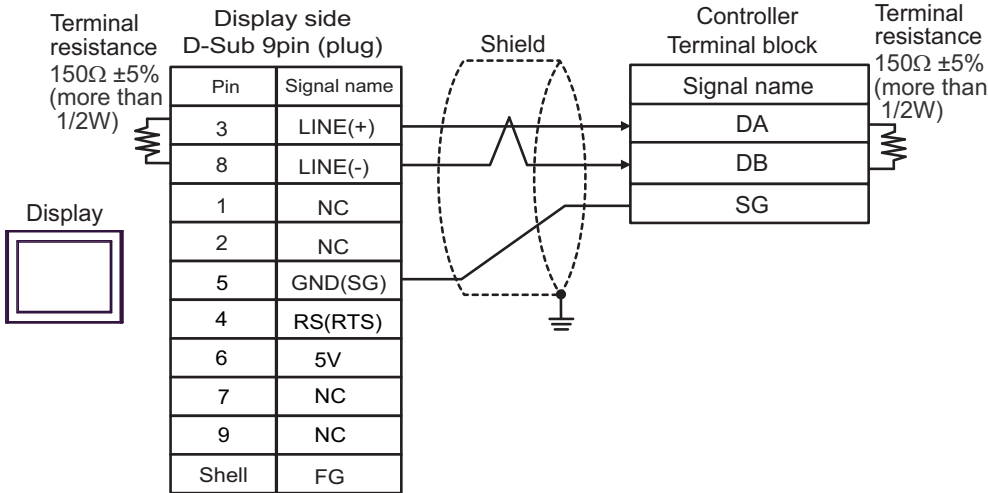

- 1:n Connection

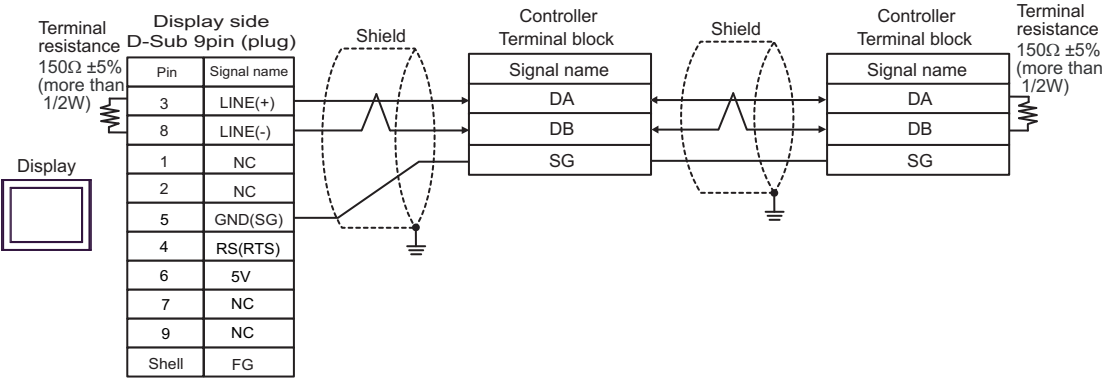

IMPORTANT • The 5V output (Pin #6) on the Display is the power for the Siemens AG's PROFIBUS connector. Do not use it for other devices.

NOTE • In COM on the GP-4107, the SG and FG terminals are isolated.

8I)

- 1:1 Connection

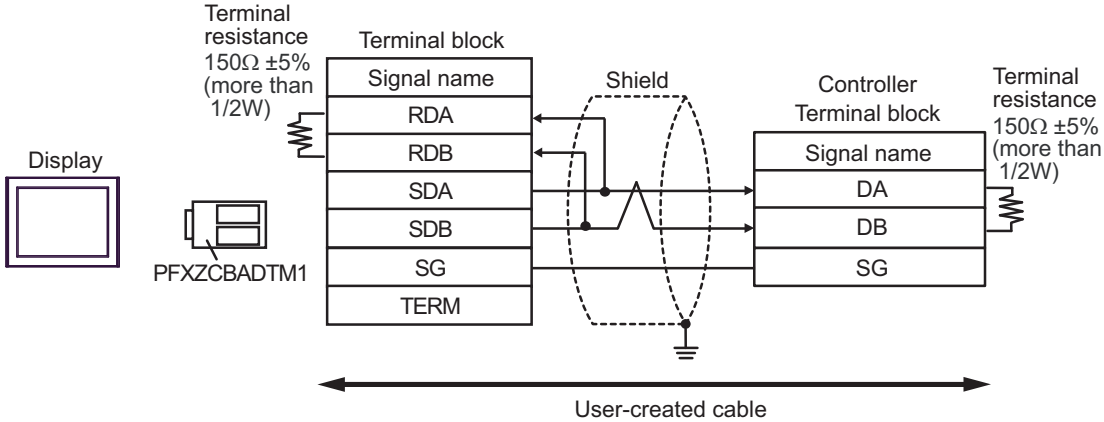

- 1:n Connection

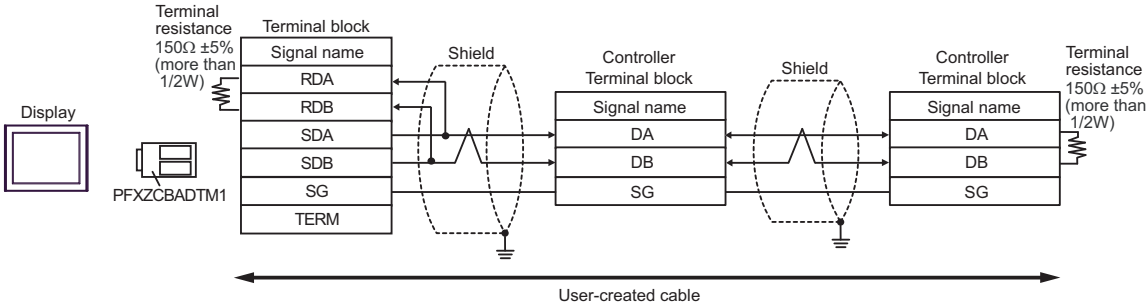

8J)

- 1:1 Connection

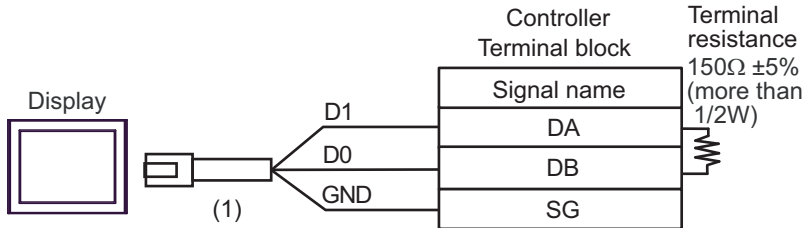

- 1:n Connection

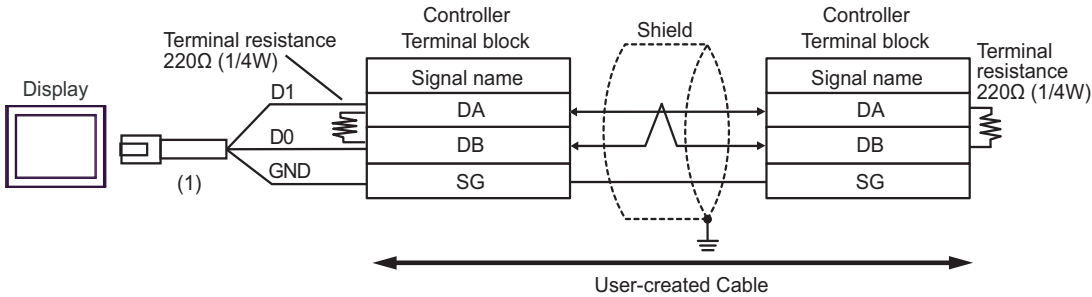

Number	Name	Notes
(1)	RJ45 RS-485 Cable (5m) by Pro-face PFXZLMCBRJR81	

8K)

- 1:1 Connection

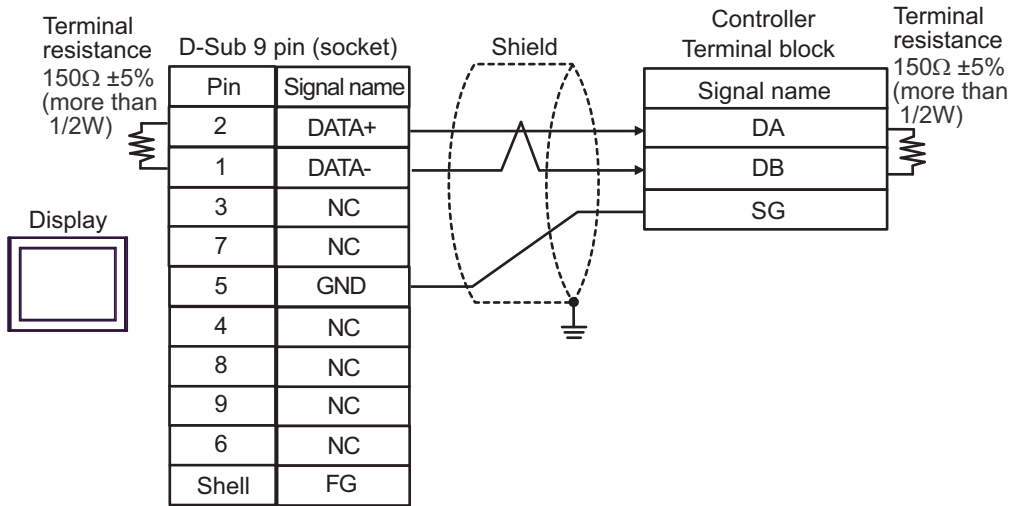

- 1:n Connection

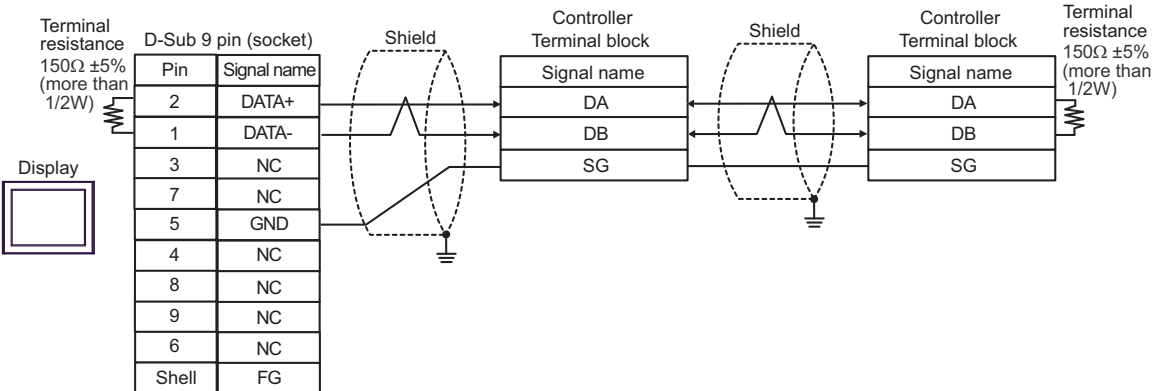

Cable Diagram 9

Display (Connection Port)	Cable		Remarks
GP3000 ^{*1} (COM1) AGP-3302B (COM2) GP-4*01TM (COM1) GP-Rear Module (COM1) ST3000 ^{*2} (COM2) LT3000 (COM1) IPC ^{*3}	9A	COM port conversion adapter by Pro-face. CA3-ADPCOM-01 + Connector terminal block conversion adapter by Pro-face CA3-ADPTRM-01 + User-created cable	Cable length: 500m or less
	9B	User-created cable	
GP3000 ^{*4} (COM2)	9C	Online adapter by Pro-face CA4-ADPONL-01 + Connector terminal block conversion adapter by Pro-face CA3-ADPTRM-01 + User-created cable	Cable length: 500m or less
	9D	Online adapter by Pro-face CA4-ADPONL-01 + User-created cable	
GP-4106 (COM1) GP-4116T (COM1)	9E	User-created cable	Cable length: 500m or less
GP4000 ^{*5} (COM2) GP-4201T (COM1) SP5000 ^{*6} (COM1/2) SP-5B00 (COM2) ST6000 ^{*7} (COM2) ST-6200 (COM1) STM6000 (COM1) STC6000 (COM1) ET6000 ^{*8} (COM2) PS6000 (Basic Box) (COM1/2)	9F	RS-422 terminal block conversion adapter by Pro-face PFXZCBADTM1 ^{*9} + User-created cable	Cable length: 500m or less
	9B	User-created cable	
PE-4000B ^{*10} PS5000 ^{*10} PS6000 (Optional Interface) ^{*10}	9G	User-created cable	Cable length: 500m or less

*1 All GP3000 models except AGP-3302B

*2 Except AST-3211A and AST-3302B

*3 Available only with COM ports that support RS-422/485 (4wire). (Except PE-4000B, PS5000, and PS6000)
 ■ IPC COM Port (page 9)

*4 All GP3000 models except the GP-3200 Series and AGP-3302B

*5 All GP4000 models except GP-4100 series, GP-4*01TM, GP-Rear Module, GP-4201T and GP-4*03T

*6 Except SP-5B00

*7 Except ST-6200

*8 Due to the COM port specifications, flow control is not possible. Omit wiring the control pins on the Display side of the cable diagram.

- *9 When using a Terminal Block Conversion Adapter (CA3-ADPTRM-01) instead of the RS-422 Terminal Block Conversion Adapter, refer to Cable Diagram 9A.
- *10 Available only with COM ports that support RS-422/485 (4wire).
 -  ■ IPC COM Port (page 9)

9B)

- 1:1 Connection

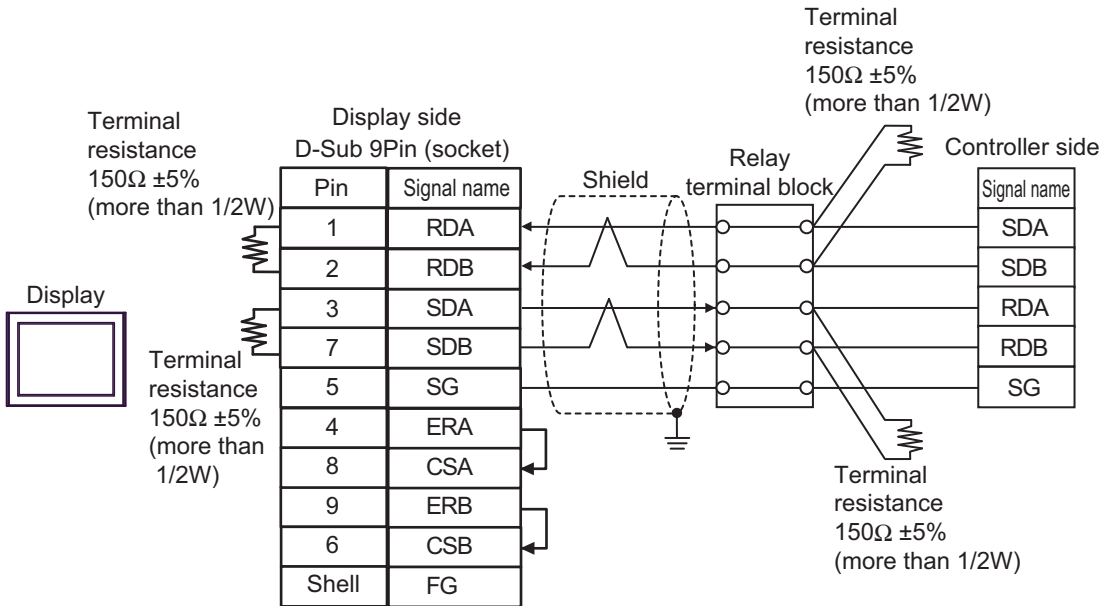

- 1:n Connection (Display is end of network)

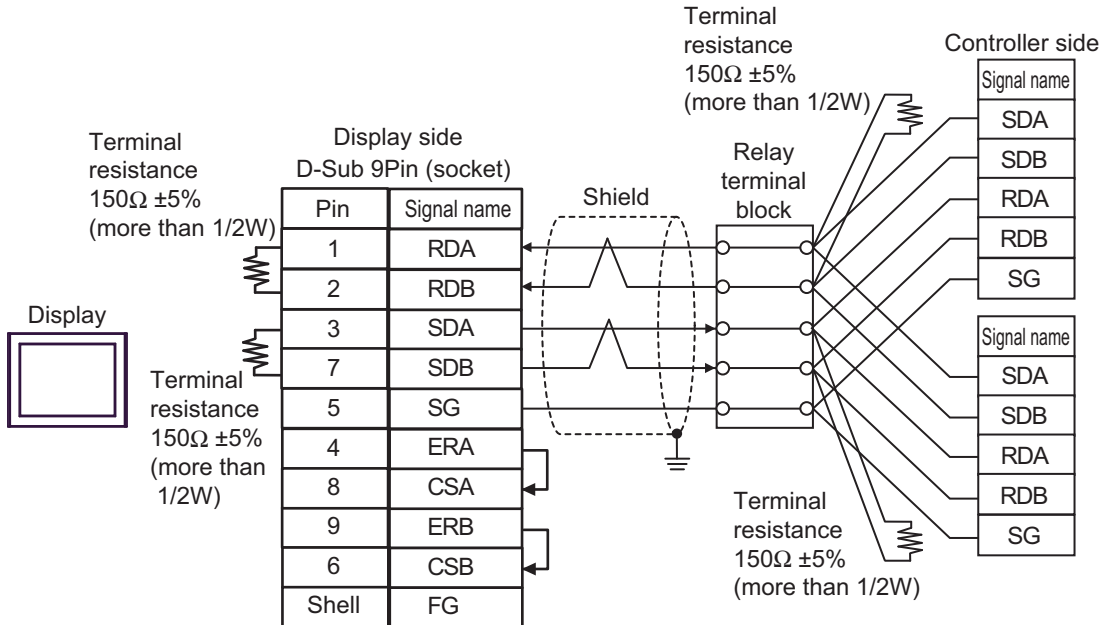

- 1:n Connection (Display is middle of network)

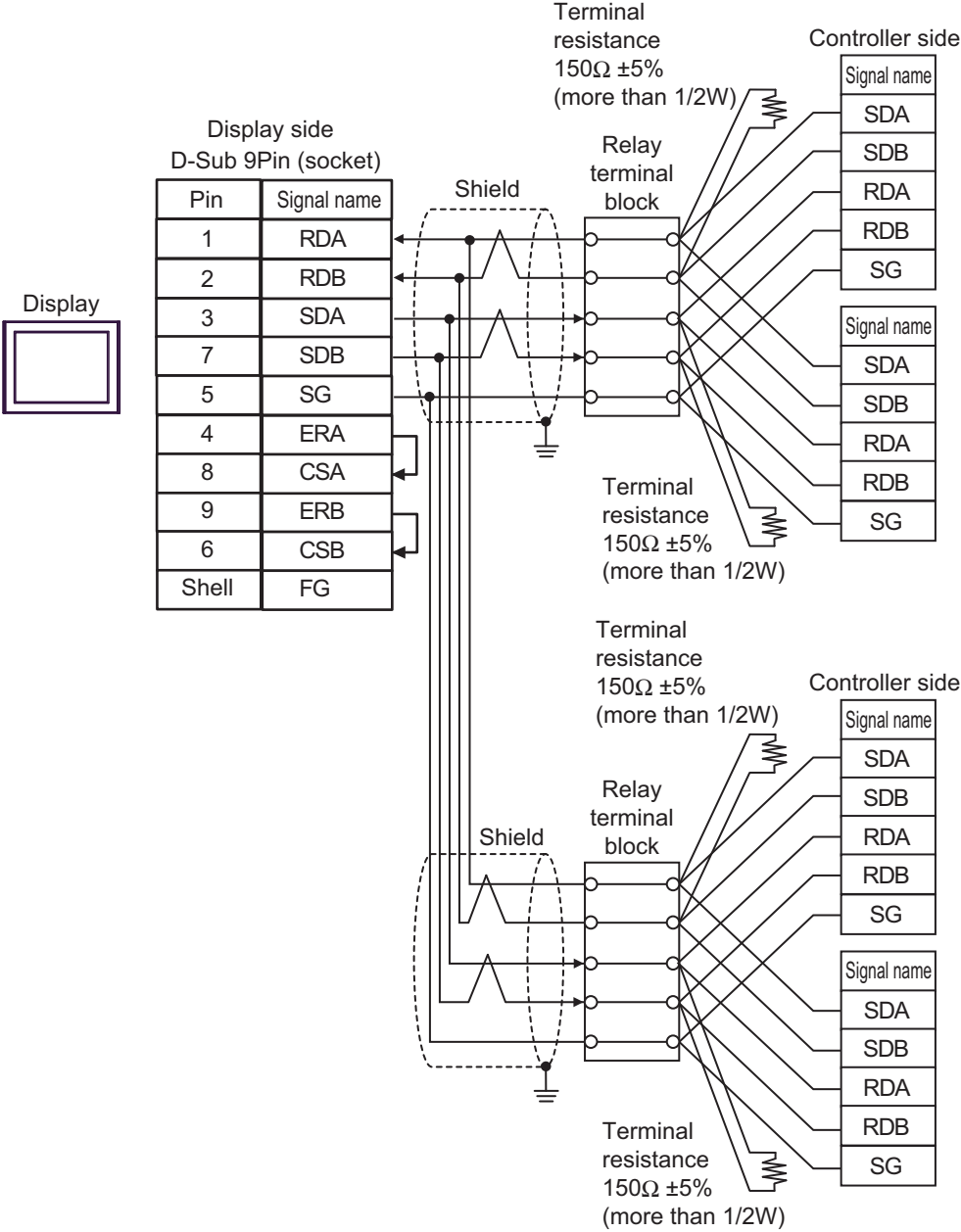

9C)

- 1:1 Connection

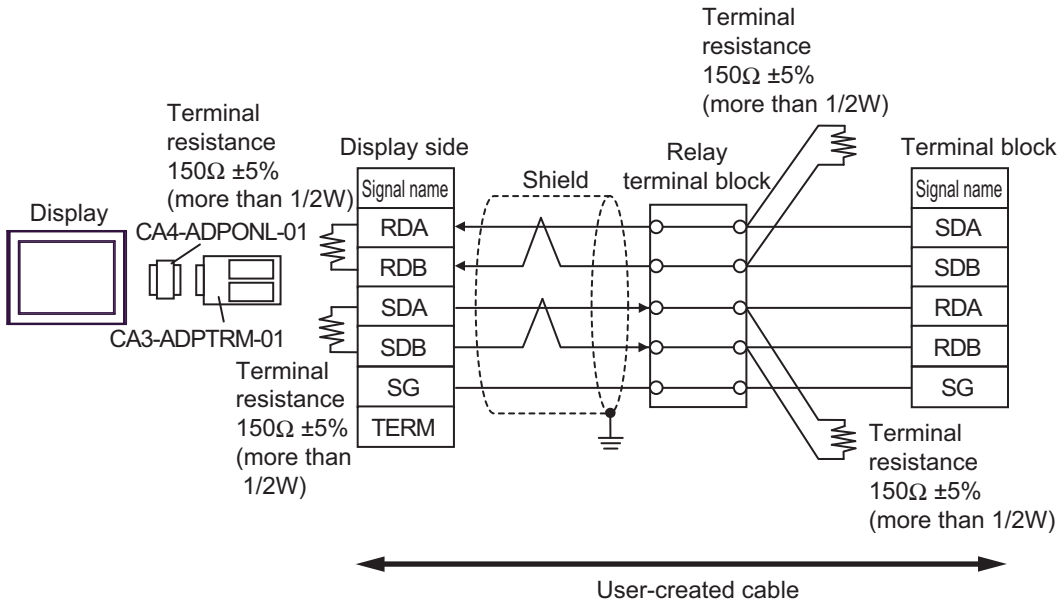

- 1:n Connection (Display is end of network)

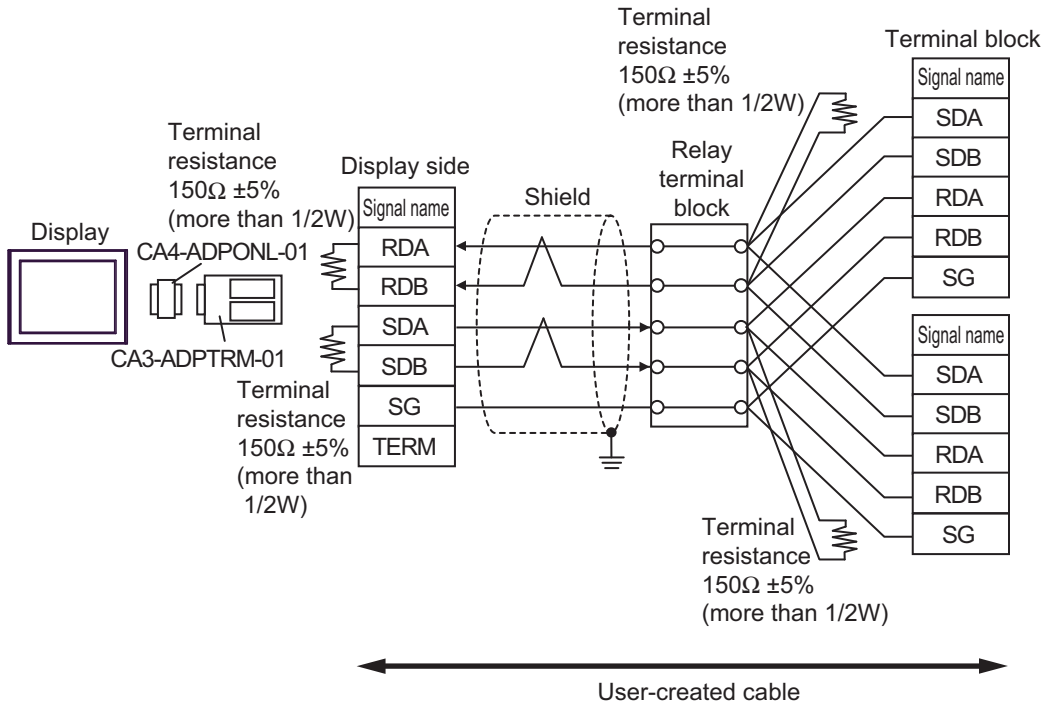

- 1:n Connection (Display is middle of network)

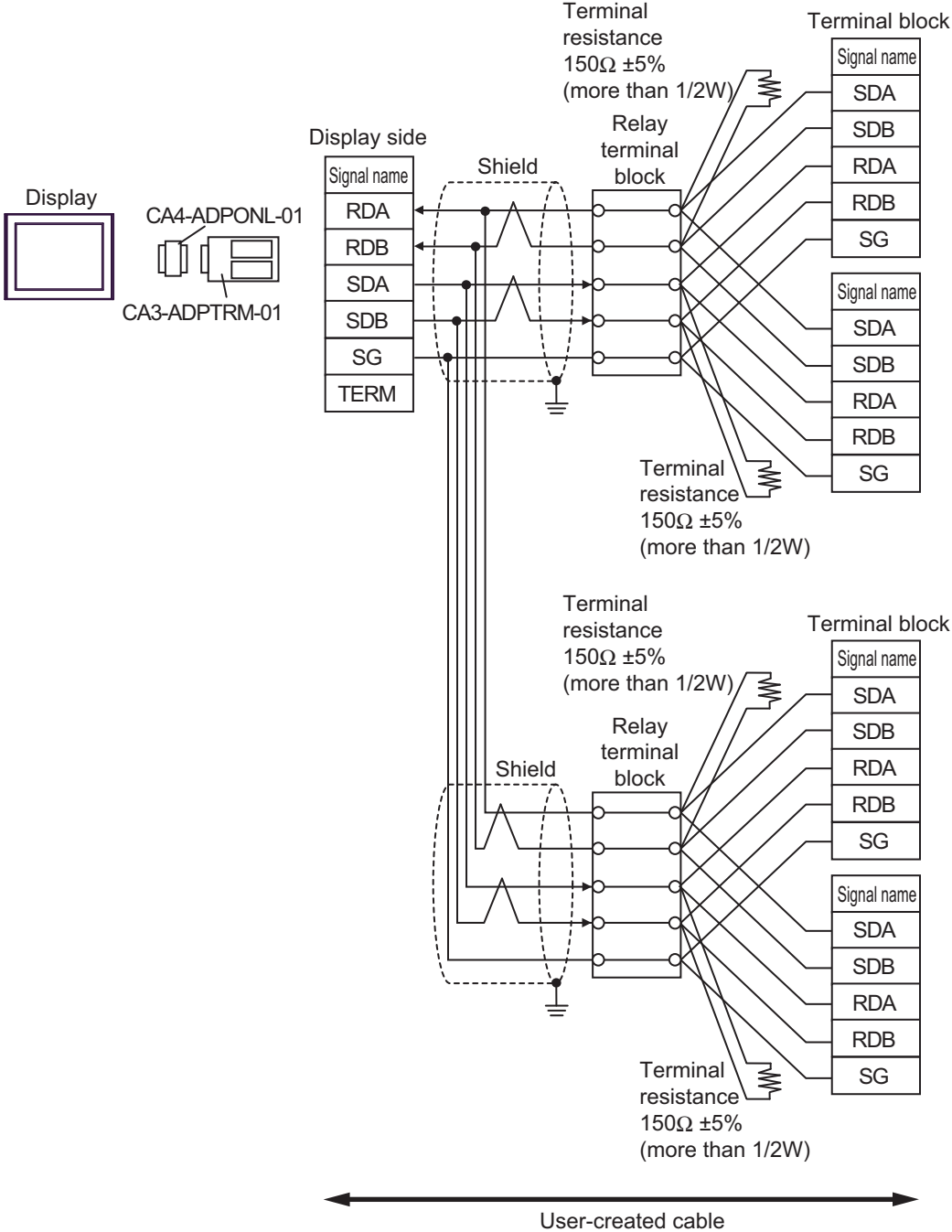

9D)

- 1:1 Connection

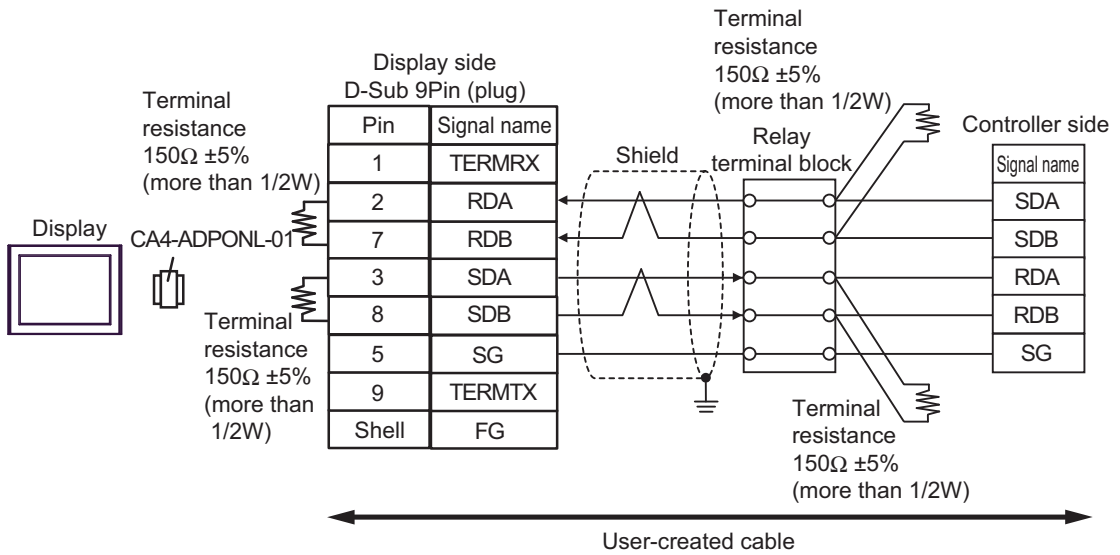

- 1:n Connection (Display is end of network)

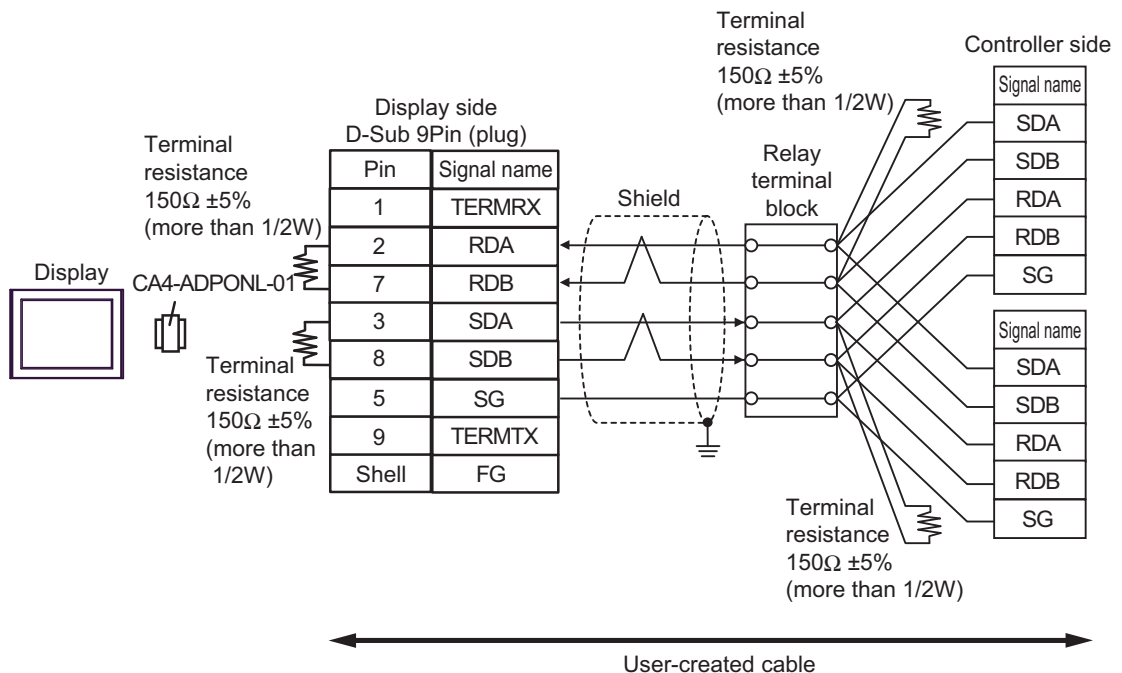

- 1:n Connection (Display is middle of network)

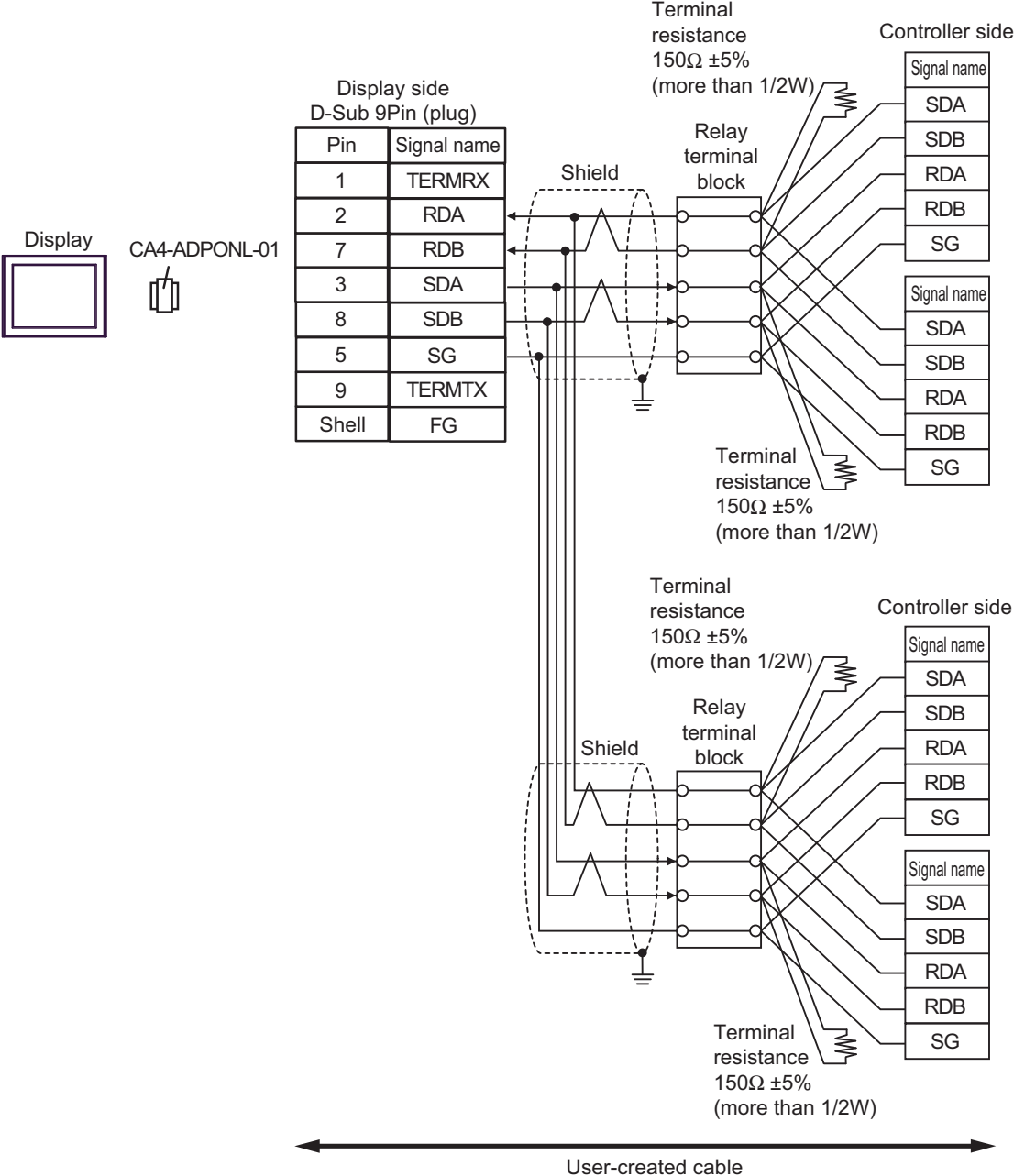

9E)

- 1:1 Connection

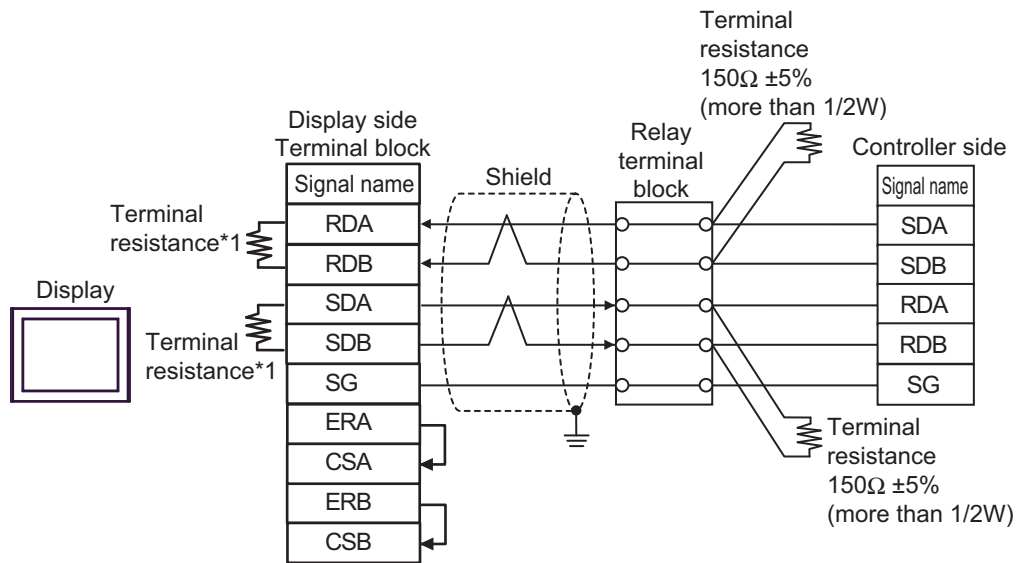

- 1:n Connection (Display is end of network)

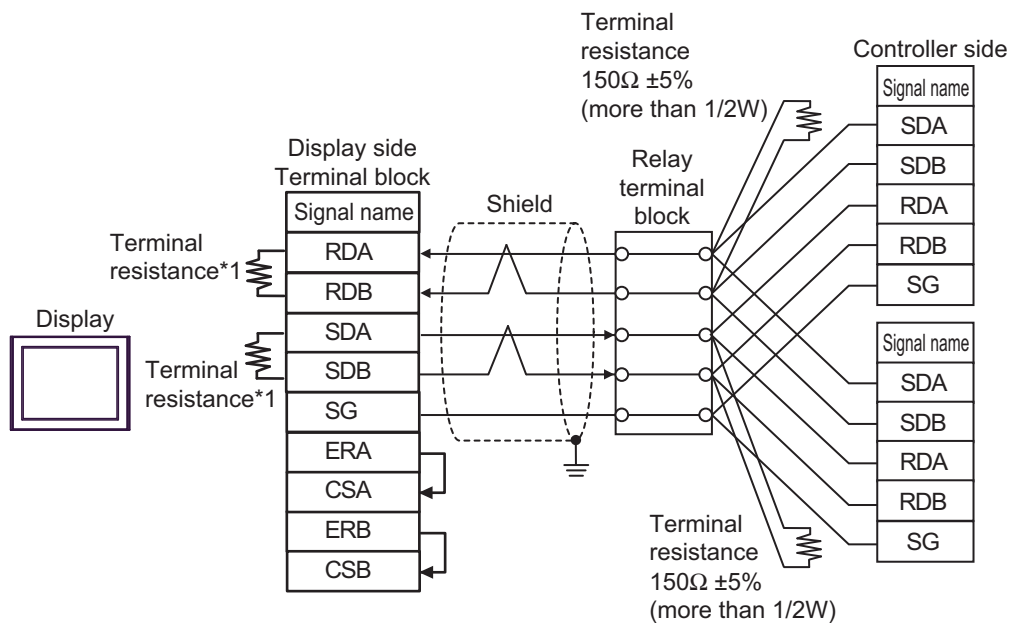

*1 The resistance in the Display is used as the termination resistance. Set the value of the DIP Switch on the rear of the Display as shown in the table below.

DIP Switch No.	Set Value
1	ON
2	ON
3	ON
4	ON

- 1:n Connection (Display is middle of network)

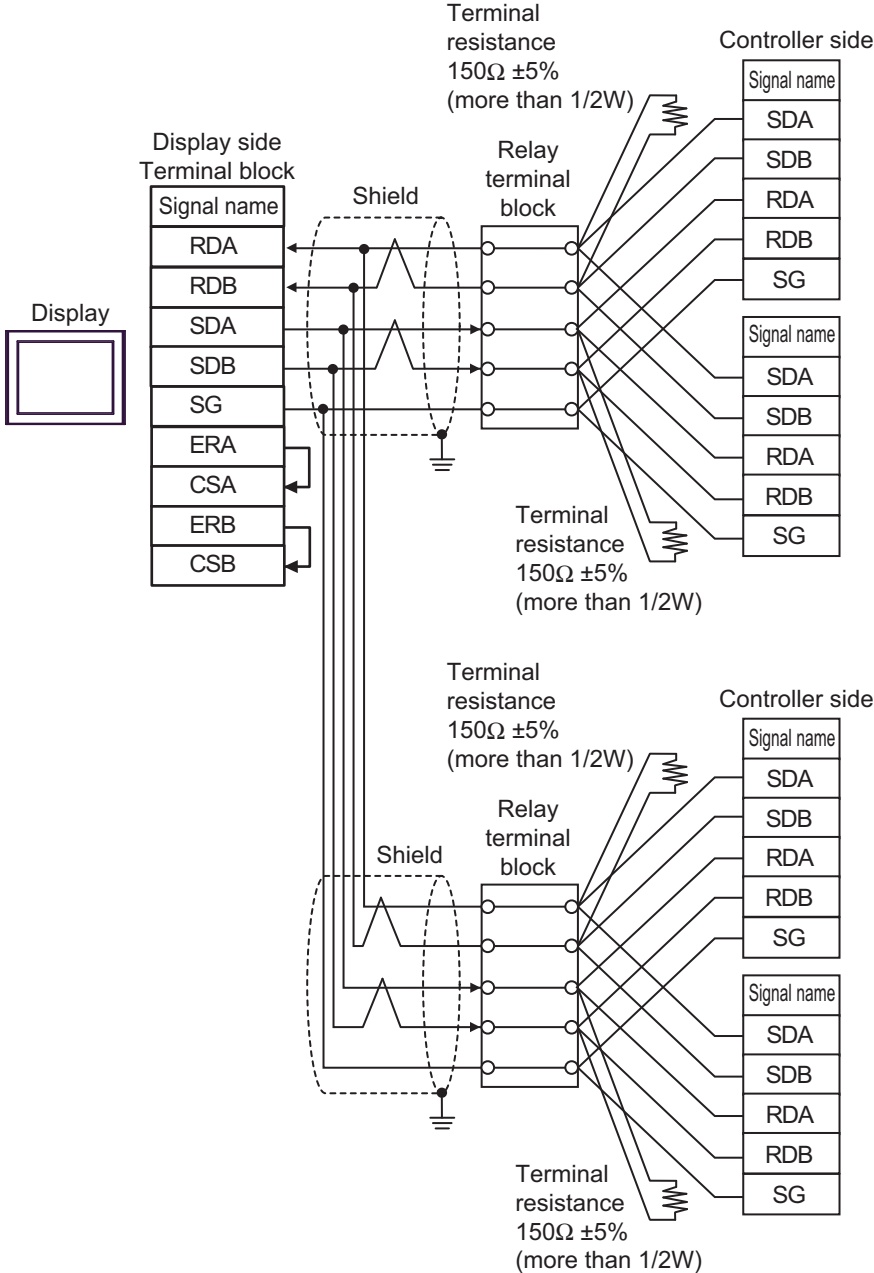

IMPORTANT • Set the DIP Switch 1-4 on the rear of the Display to OFF.

9F)

- 1:1 Connection

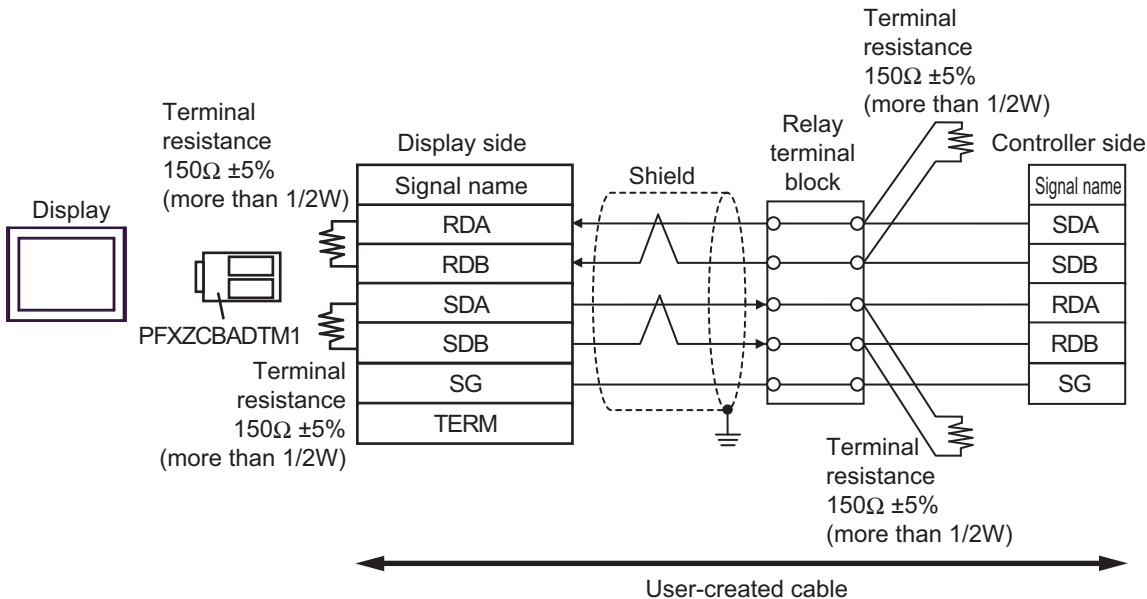

- 1:n Connection (Display is end of network)

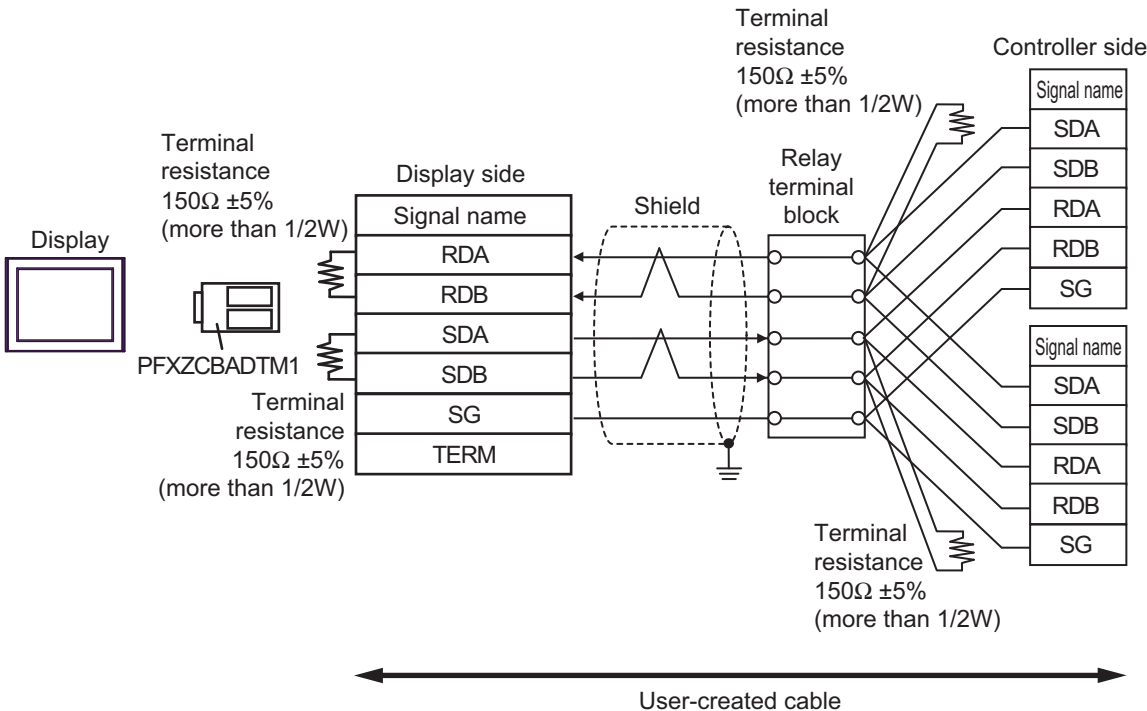

- 1:n Connection (Display is middle of network)

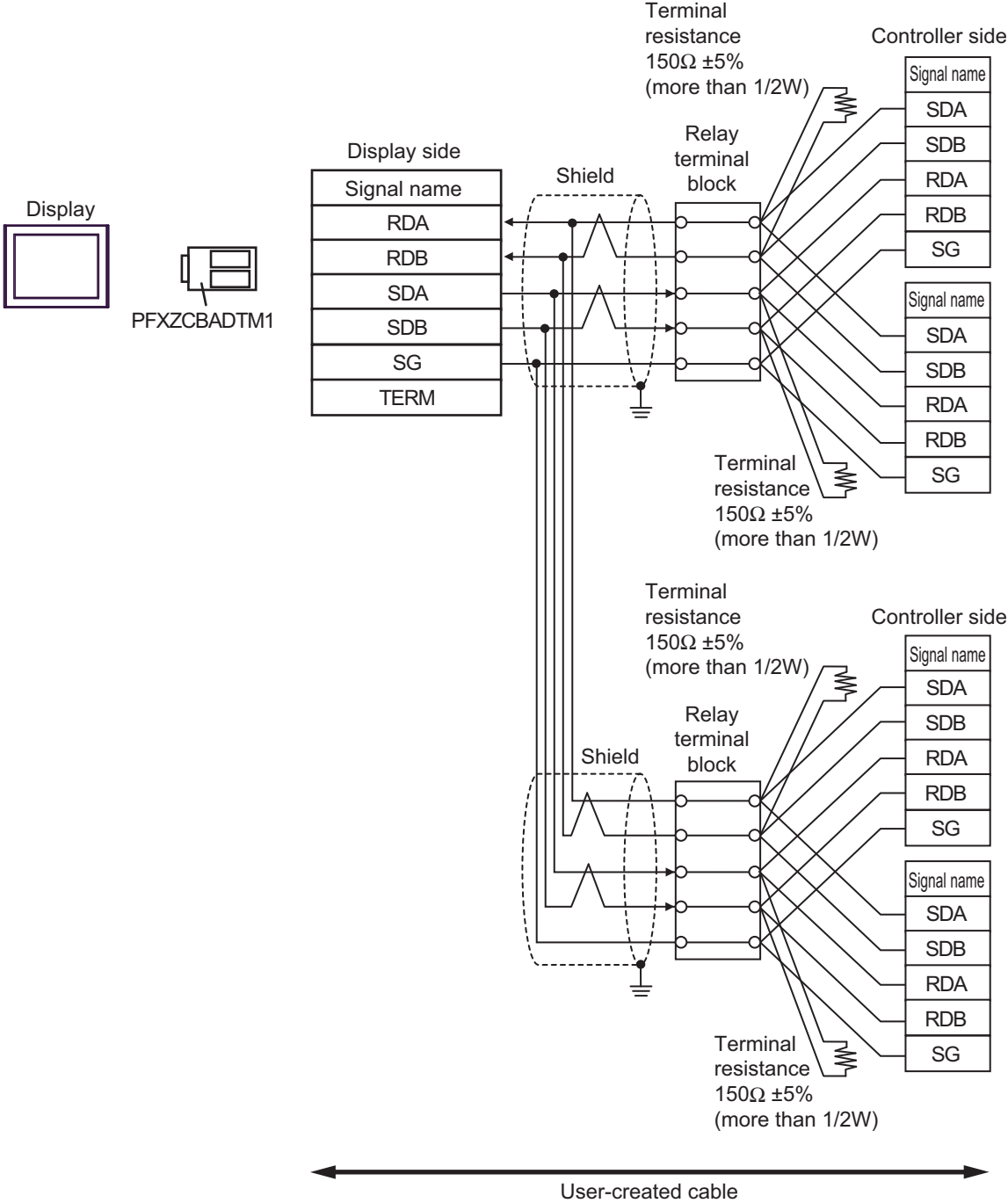

9G)

- 1:1 Connection

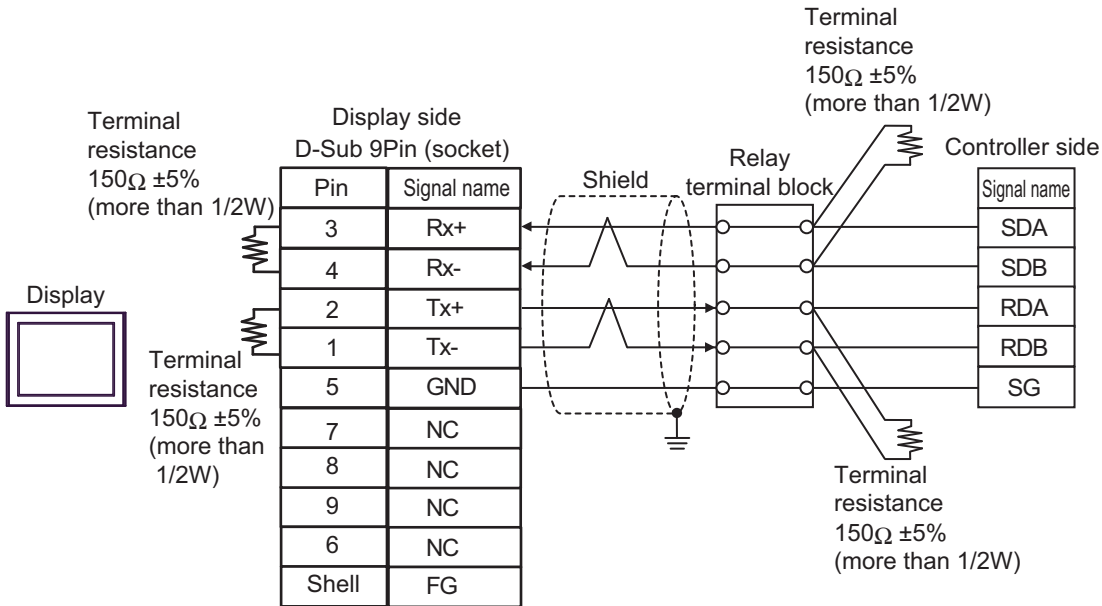

- 1:n Connection (Display is end of network)

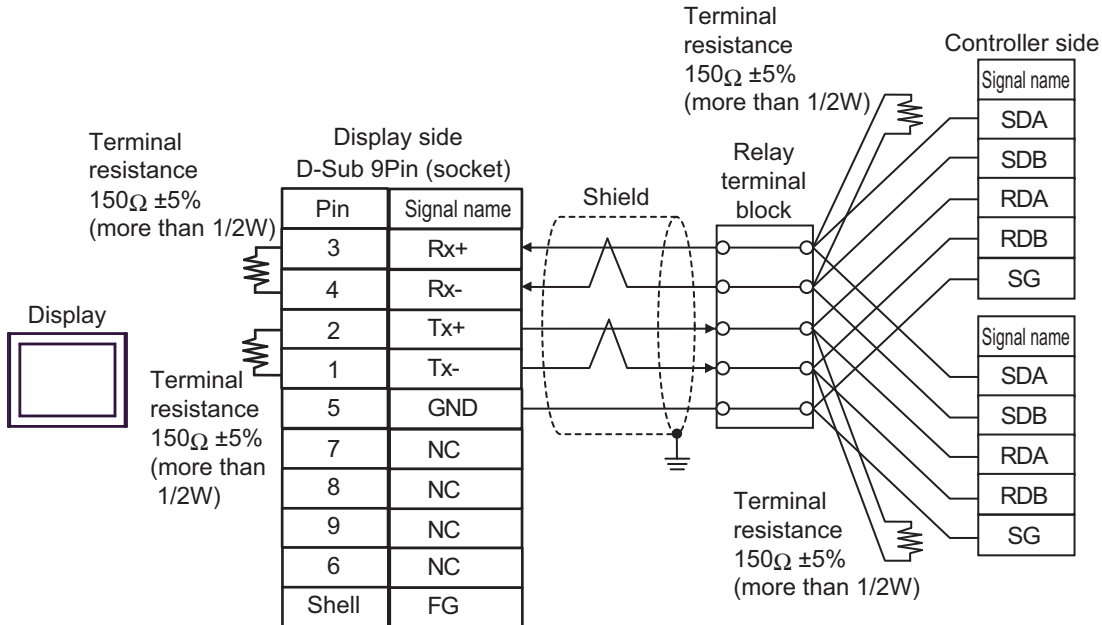

- 1:n Connection (Display is middle of network)

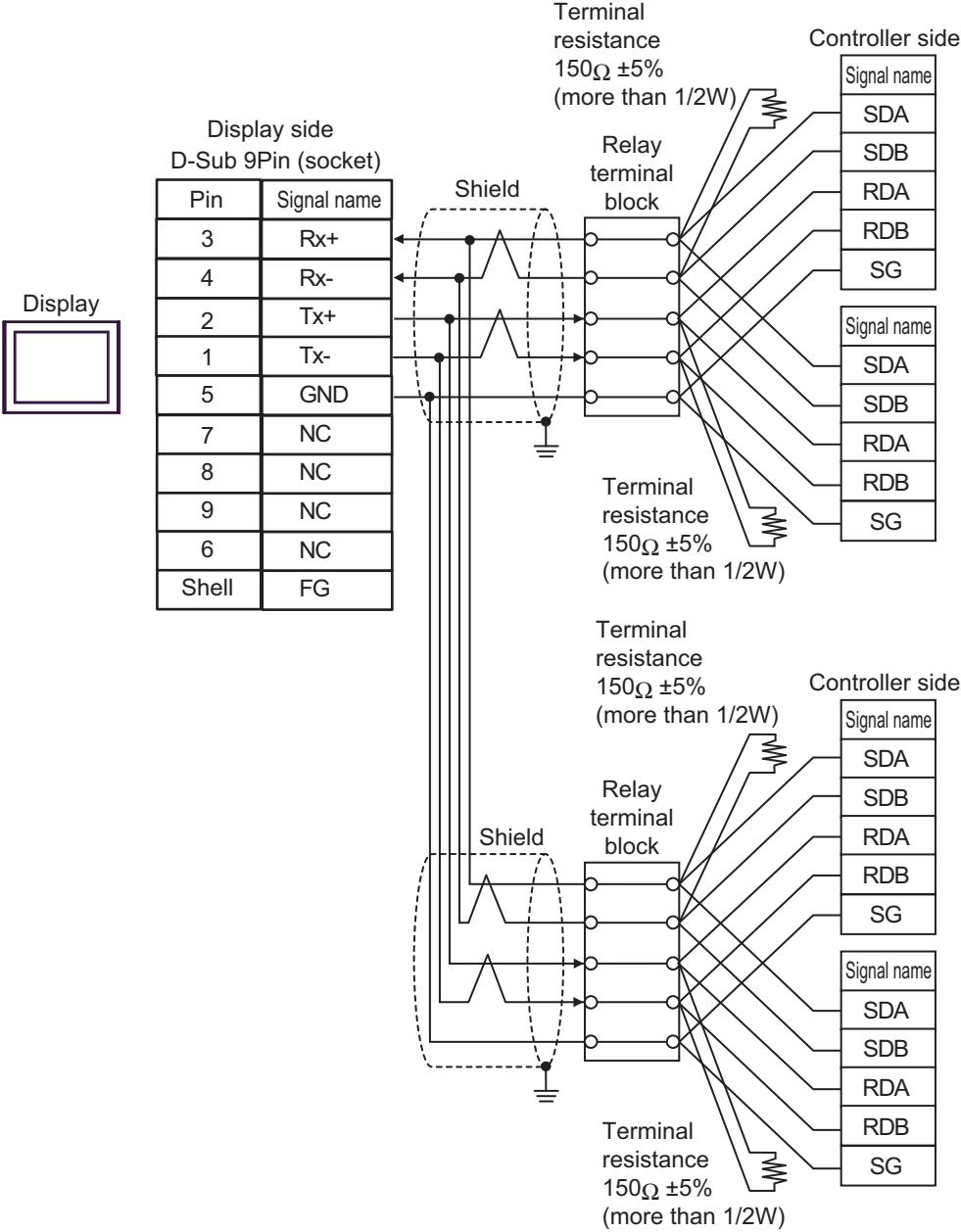

Cable Diagram 10

Display (Connection Port)	Cable		Remarks
GP3000* ¹ (COM1) AGP-3302B (COM2) GP-4*01TM (COM1) GP-Rear Module (COM1) ST3000* ² (COM2) LT3000 (COM1)	10A	COM port conversion adapter by Pro-face. CA3-ADPCOM-01 + Connector terminal block conversion adapter by Pro-face CA3-ADPTRM-01 + User-created cable	Cable length: 500m or less
	10B	User-created cable	
GP3000* ³ (COM2)	10C	Online adapter by Pro-face CA4-ADPONL-01 + Connector terminal block conversion adapter by Pro-face CA3-ADPTRM-01 + User-created cable	Cable length: 500m or less
	10D	Online adapter by Pro-face CA4-ADPONL-01 + User-created cable	
IPC* ⁴	10E	COM port conversion adapter by Pro-face. CA3-ADPCOM-01 + Connector terminal block conversion adapter by Pro-face CA3-ADPTRM-01 + User-created cable	Cable length: 500m or less
	10F	User-created cable	
GP-4106 (COM1) GP-4116T (COM1)	10G	User-created cable	Cable length: 500m or less
GP-4107 (COM1) GP-4*03T* ⁵ (COM2) GP-4203T (COM1)	10H	User-created cable	Cable length: 500m or less
GP4000* ⁶ (COM2) GP-4201T (COM1) SP5000* ⁷ (COM1/2) SP-5B00 (COM2) ST6000* ⁸ (COM2) ST-6200 (COM1) STM6000 (COM1) STC6000 (COM1) ET6000* ⁹ (COM2) PS6000 (Basic Box) (COM1/2)	10I	RS-422 terminal block conversion adapter by Pro-face PFXZCBADTM1* ¹⁰ + User-created cable	Cable length: 500m or less
	10B	User-created cable	
LT-4*01TM (COM1) LT-Rear Module (COM1)	10J	RJ45 RS-485 Cable (5m) by Pro-face PFXZLMCBRJR81	Cable length: 200m or less
PE-4000B* ¹¹ PS5000* ¹¹ PS6000 (Optional Interface)* ¹¹	10K	User-created cable	Cable length: 500m or less

*1 All GP3000 models except AGP-3302B

- *2 Except AST-3211A and AST-3302B
- *3 All GP3000 models except the GP-3200 Series and AGP-3302B
- *4 Available only with COM ports that support RS-422/485 (2wire). (Except PE-4000B, PS5000, and PS6000)
 ☞ ■ IPC COM Port (page 9)
- *5 Except GP-4203T
- *6 All GP4000 models except GP-4100 series, GP-4*01TM, GP-Rear Module, GP-4201T and GP-4*03T
- *7 Except SP-5B00
- *8 Except ST-6200
- *9 Due to the COM port specifications, flow control is not possible. Omit wiring the control pins on the Display side of the cable diagram.
- *10 When using a Terminal Block Conversion Adapter (CA3-ADPTRM-01) instead of the RS-422 Terminal Block Conversion Adapter, refer to Cable Diagram 10A.
- *11 Available only with COM ports that support RS-422/485 (2wire).
 ☞ ■ IPC COM Port (page 9)

10A)

- 1:1 Connection

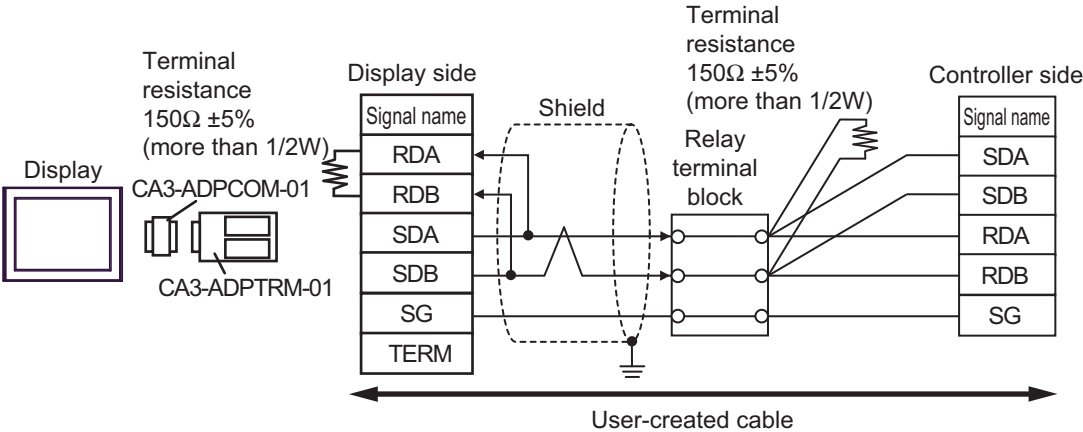

- 1:n Connection (Display is end of network)

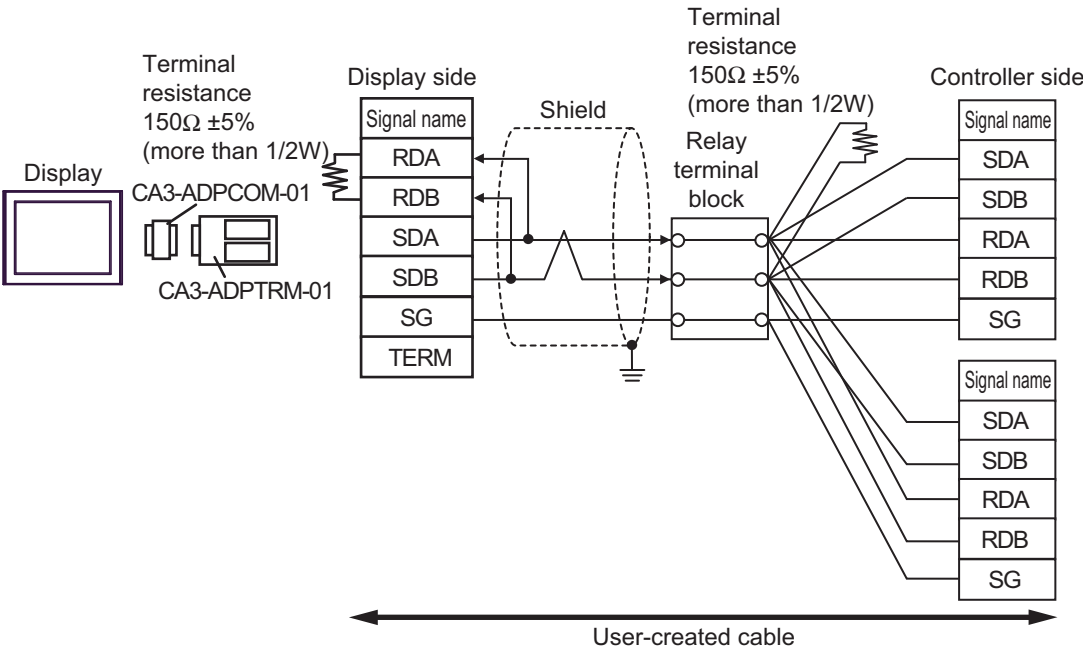

- 1:n Connection (Display is middle of network)

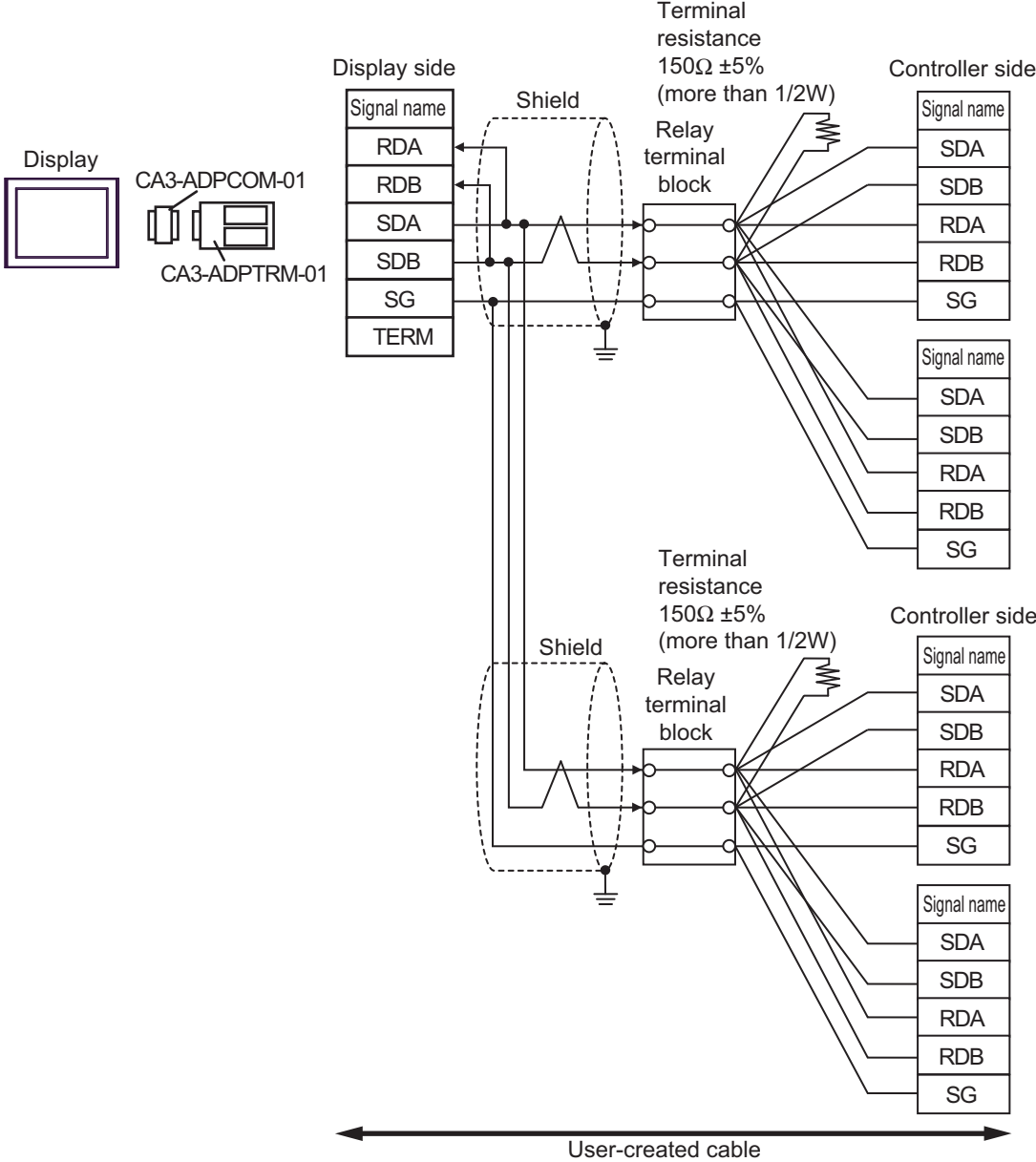

10B)

- 1:1 Connection

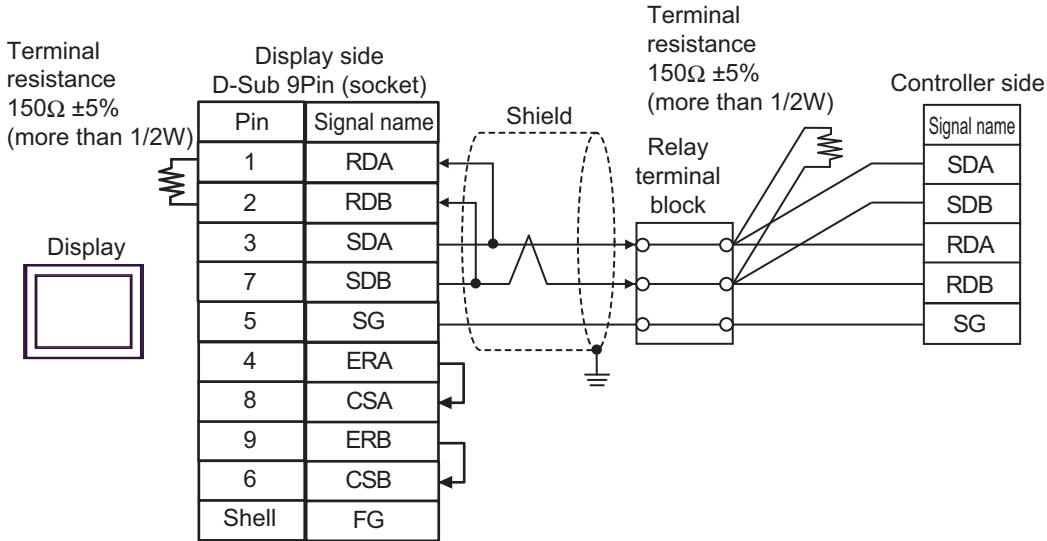

- 1:n Connection (Display is end of network)

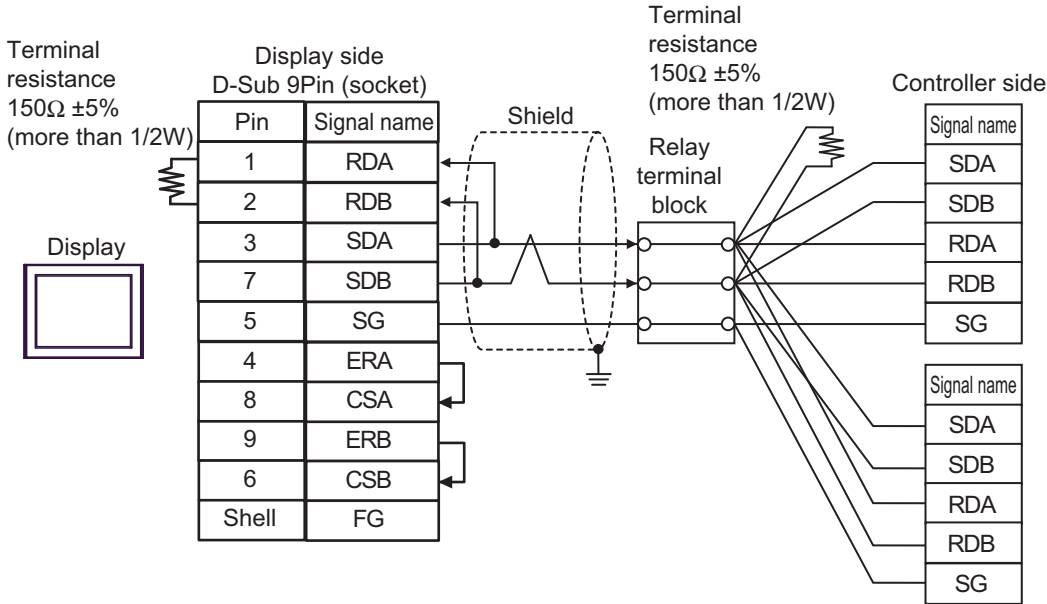

- 1:n Connection (Display is middle of network)

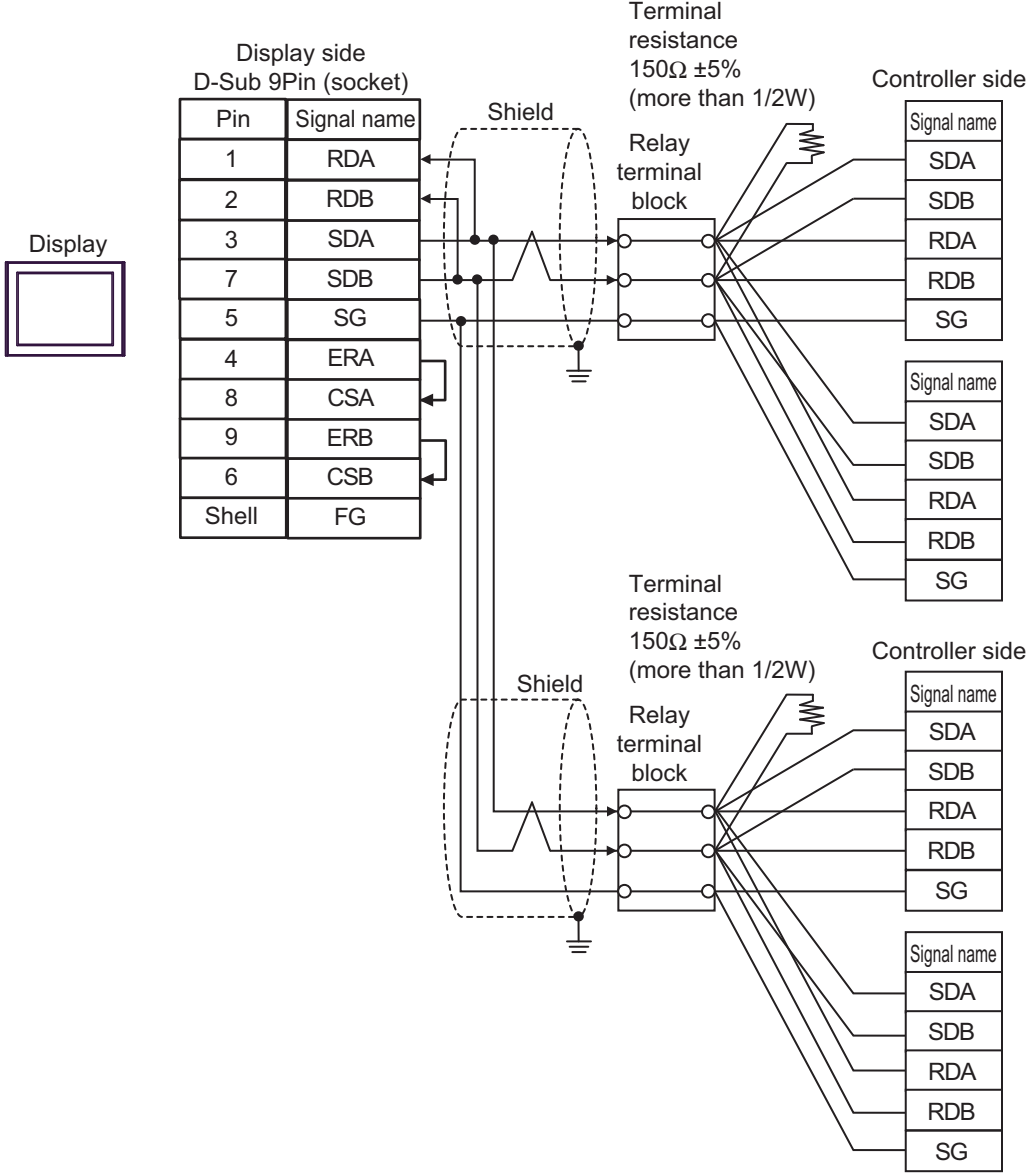

10C)

- 1:1 Connection

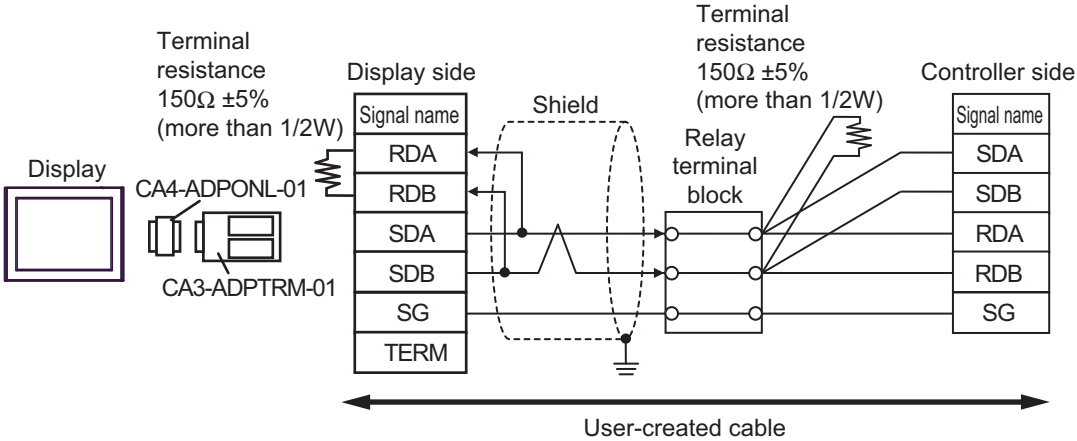

- 1:n Connection (Display is end of network)

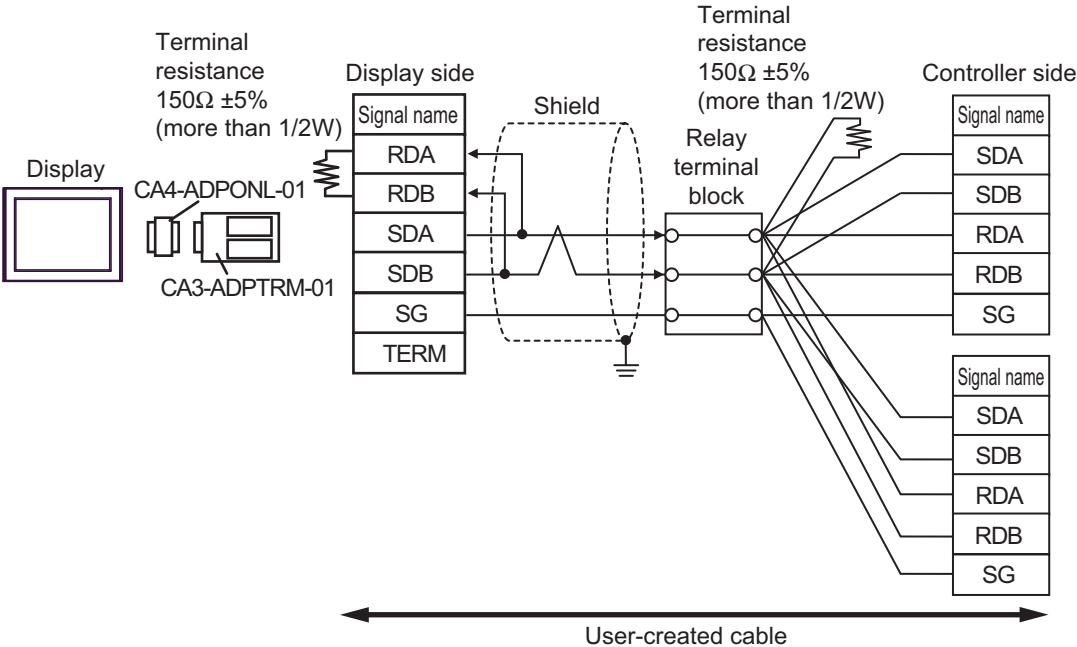

- 1:n Connection (Display is middle of network)

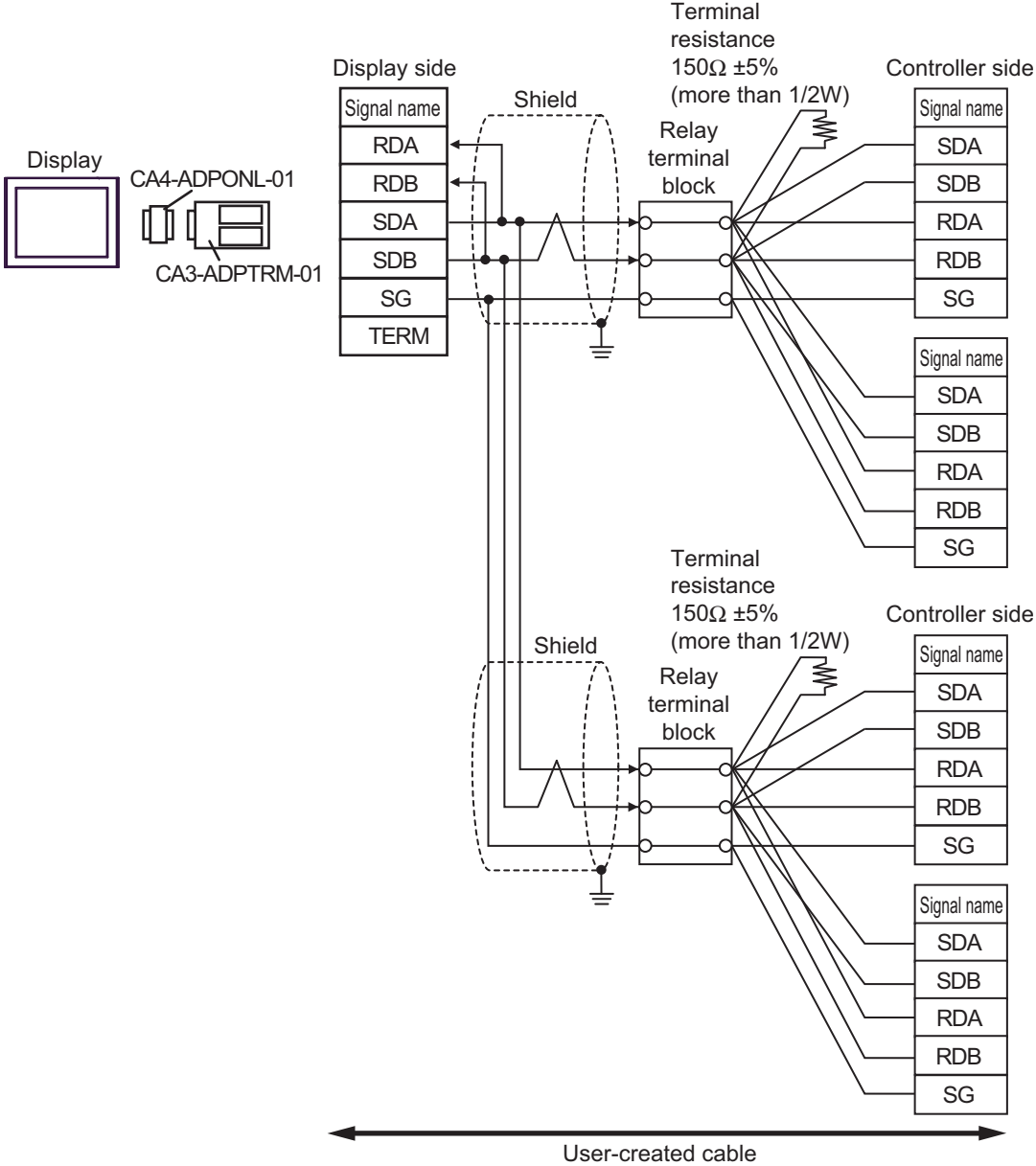

10D)

- 1:1 Connection

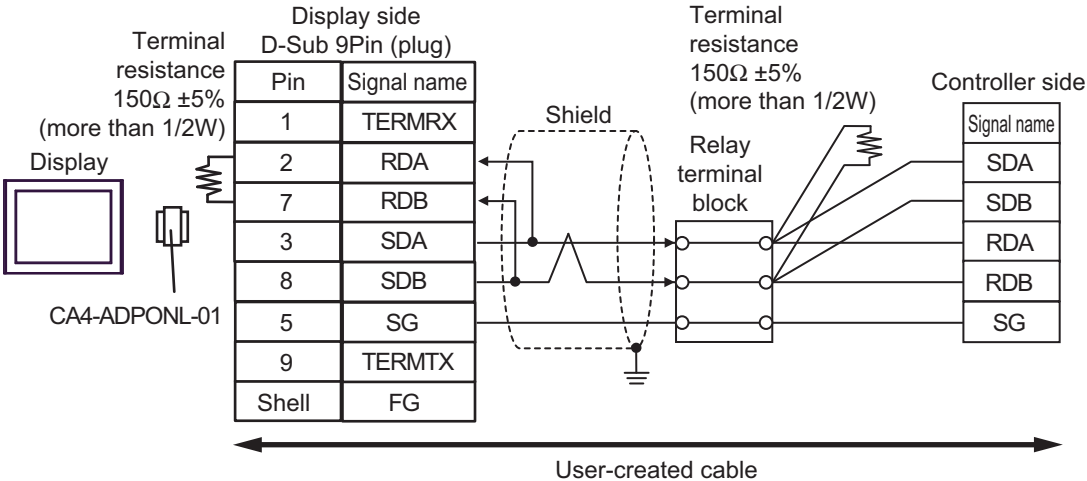

- 1:n Connection (Display is end of network)

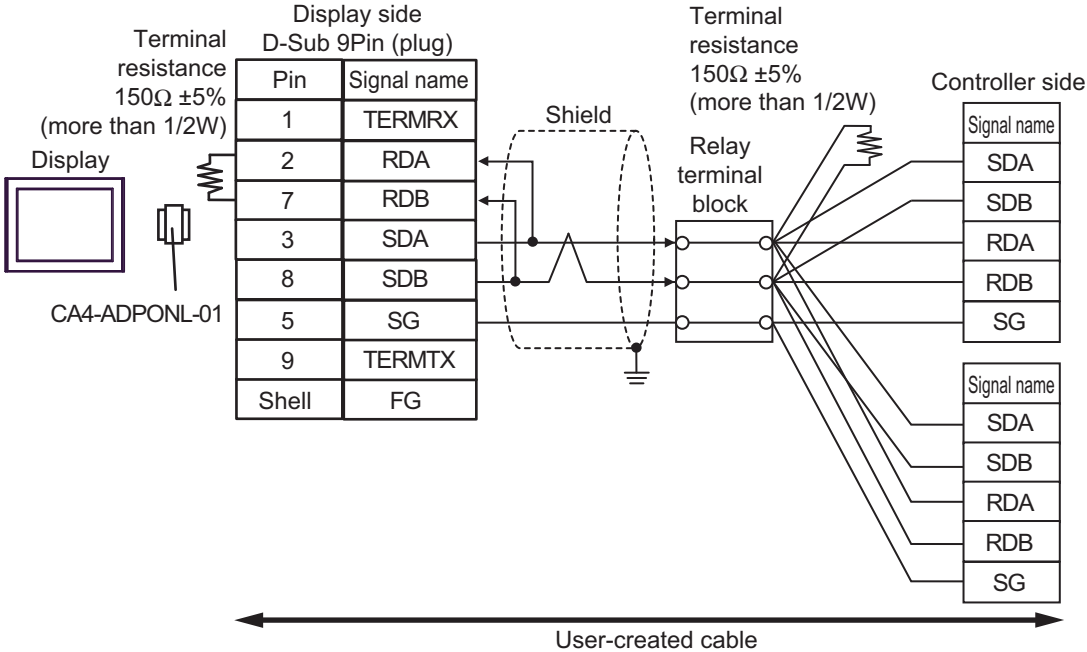

- 1:n Connection (Display is middle of network)

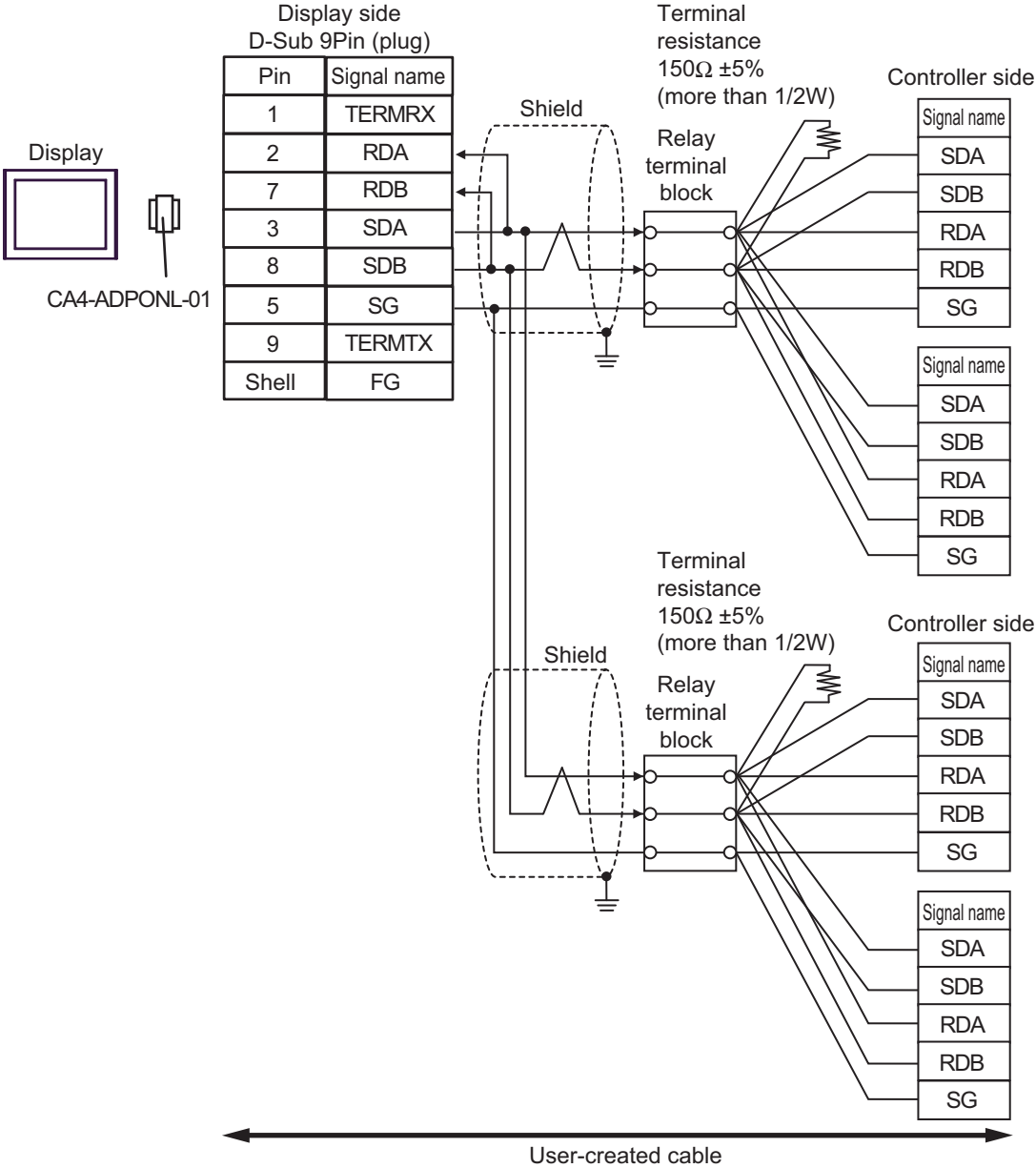

10E)

- 1:1 Connection

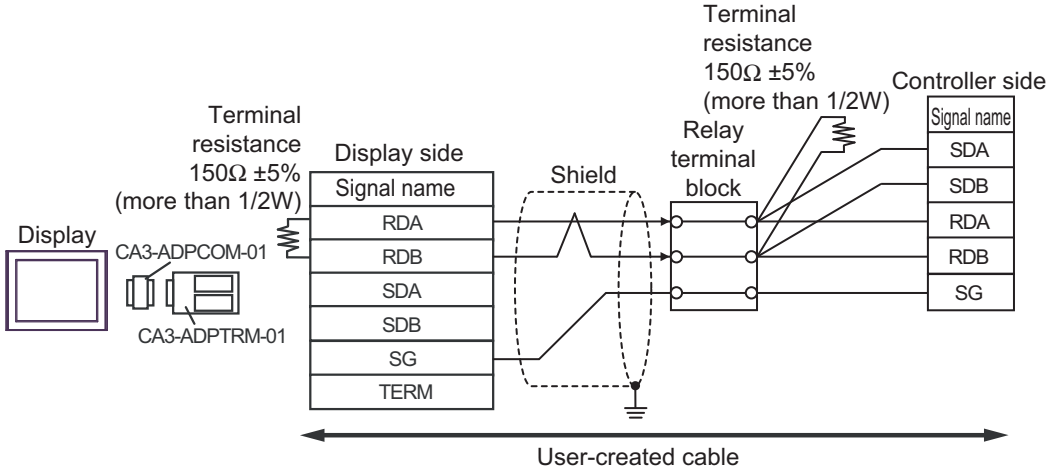

- 1:n Connection (Display is end of network)

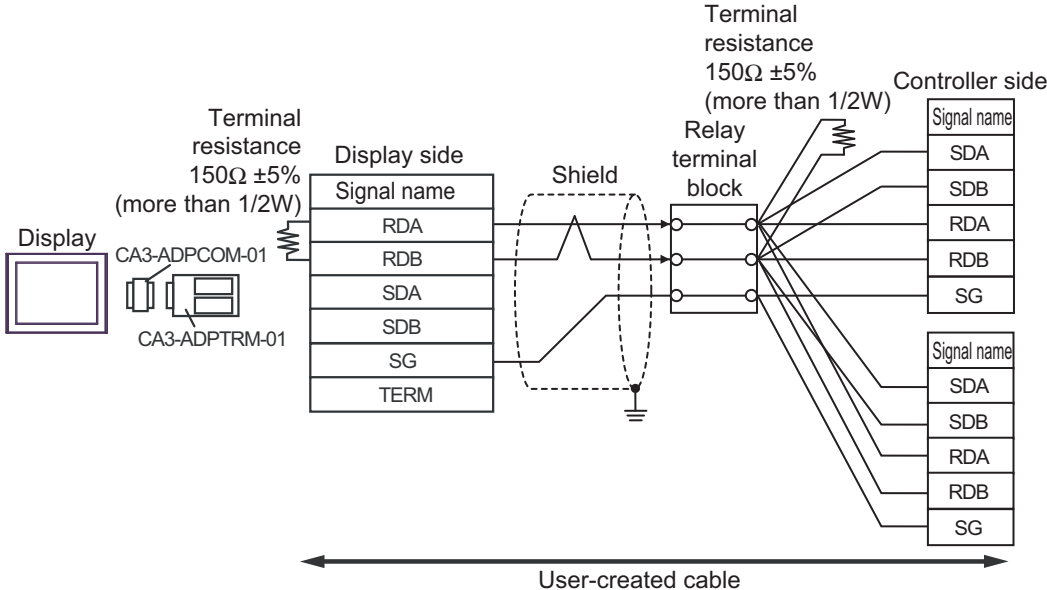

- 1:n Connection (Display is middle of network)

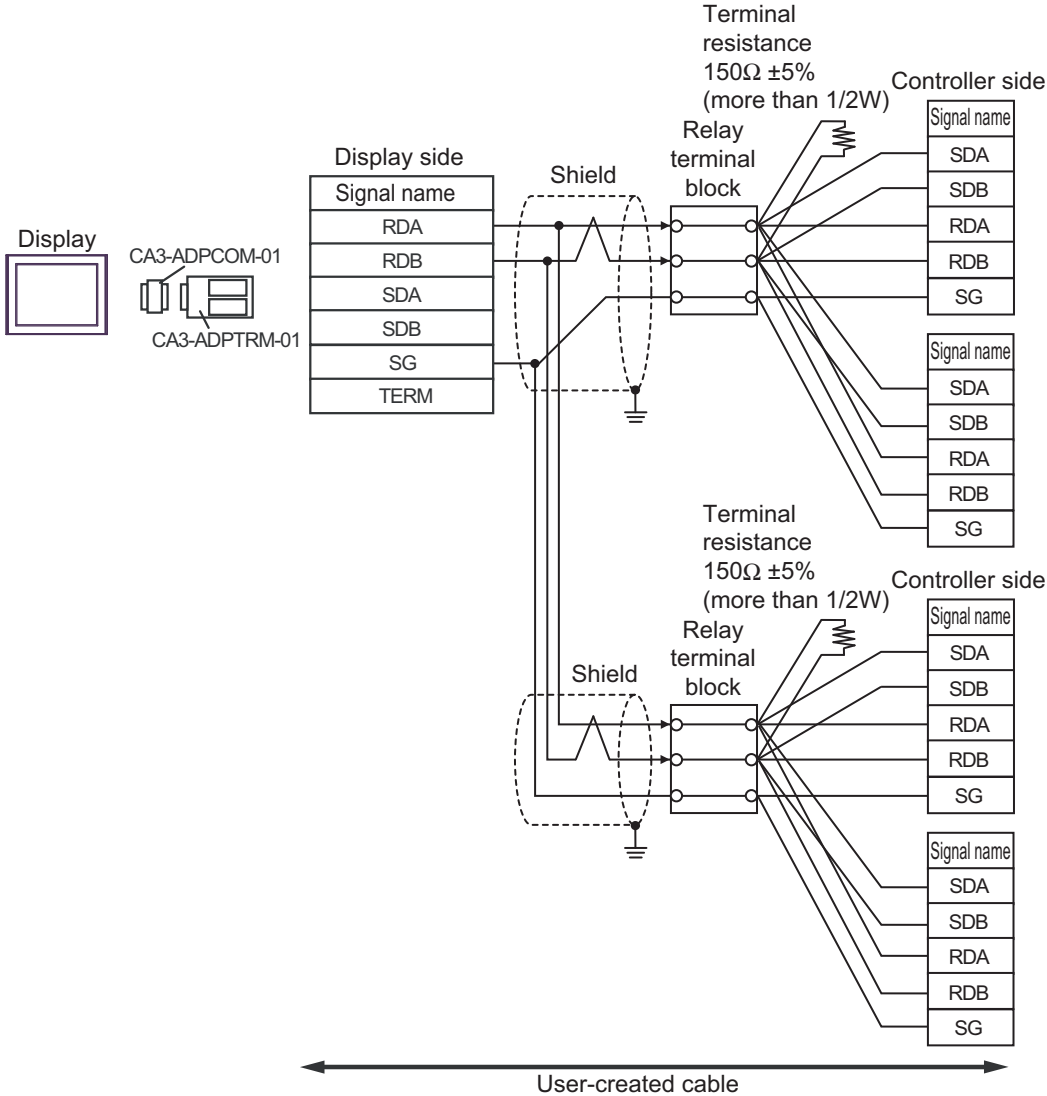

10F)

- 1:1 Connection

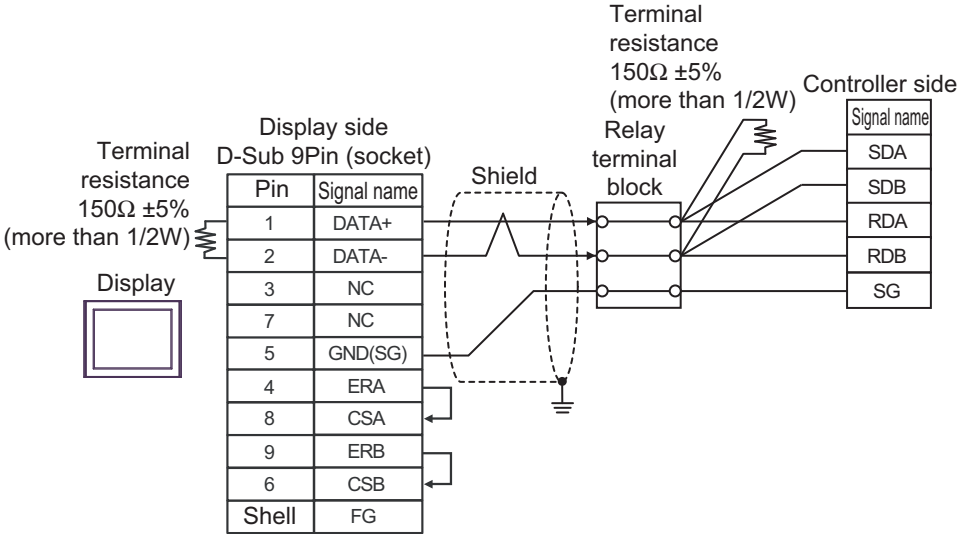

- 1:n Connection (Display is end of network)

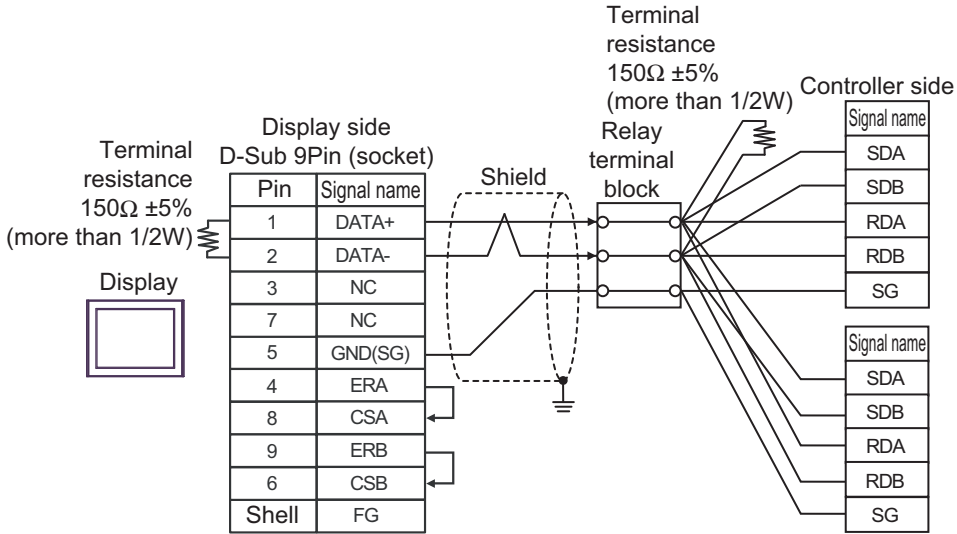

- 1:n Connection (Display is middle of network)

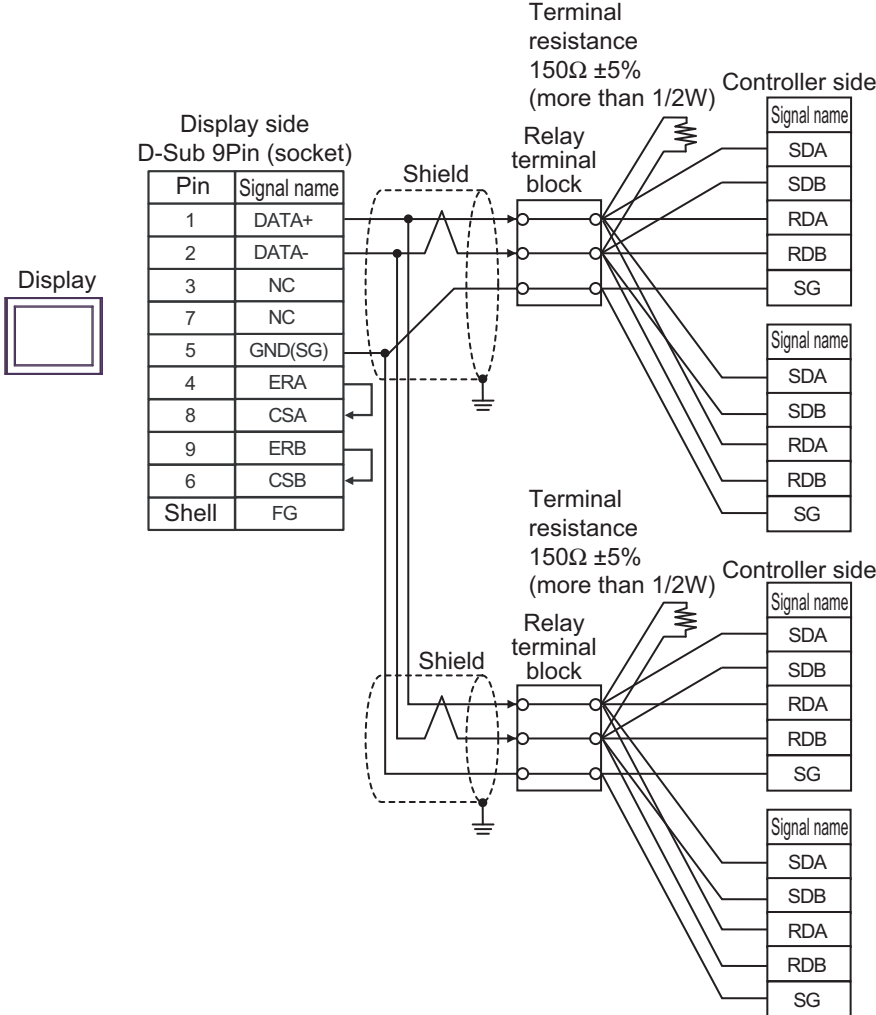

10G)

- 1:1 Connection

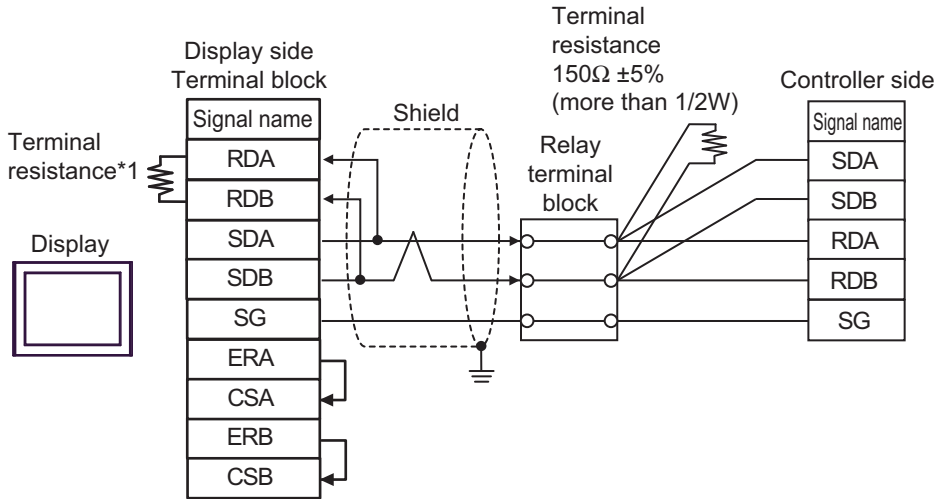

- 1:n Connection (Display is end of network)

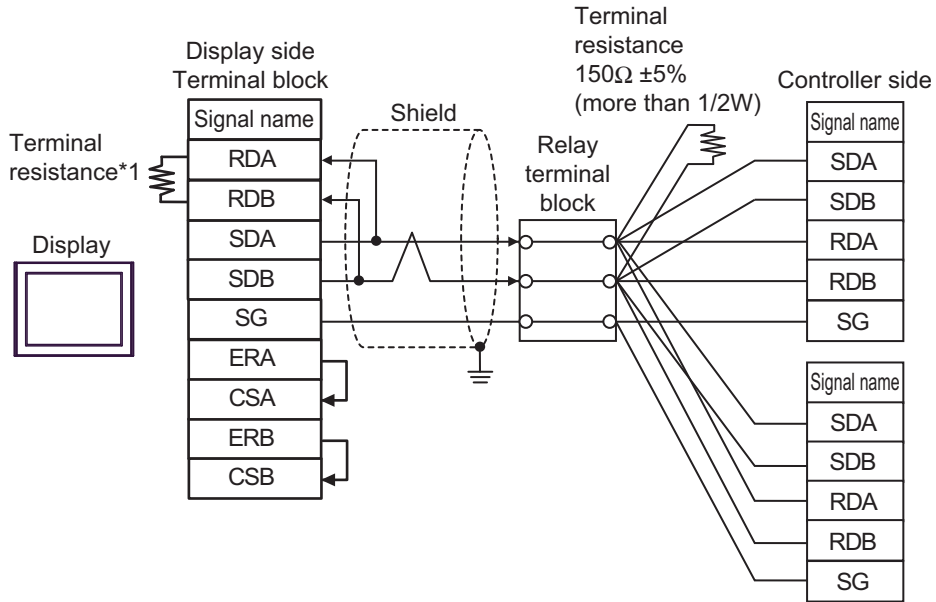

*1 The resistance in the Display is used as the termination resistance. Set the value of the DIP Switch on the rear of the Display as shown in the table below.

DIP Switch No.	Set Value
1	OFF
2	OFF
3	ON
4	ON

- 1:n Connection (Display is middle of network)

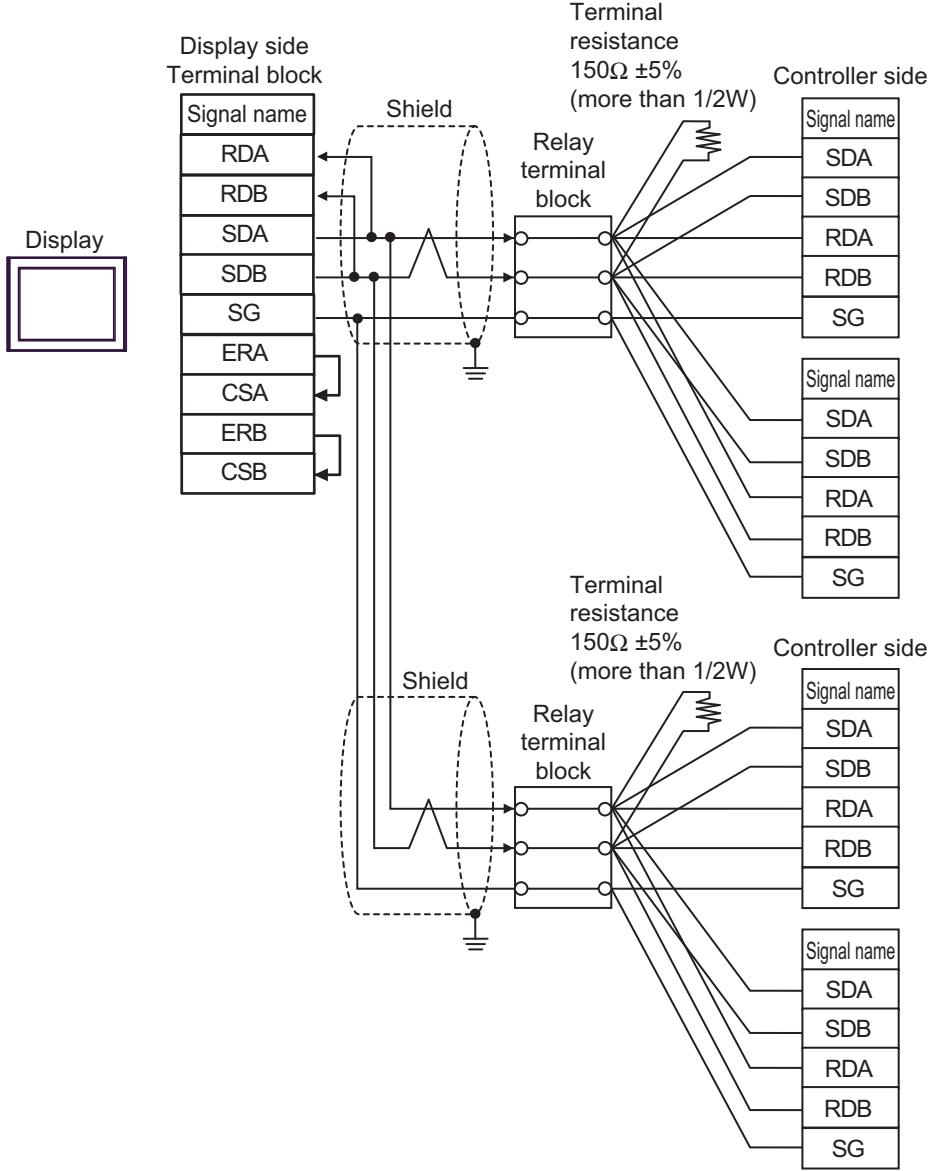

IMPORTANT • Set the DIP Switch 1-4 on the rear of the Display to OFF.

10H)

- 1:1 Connection

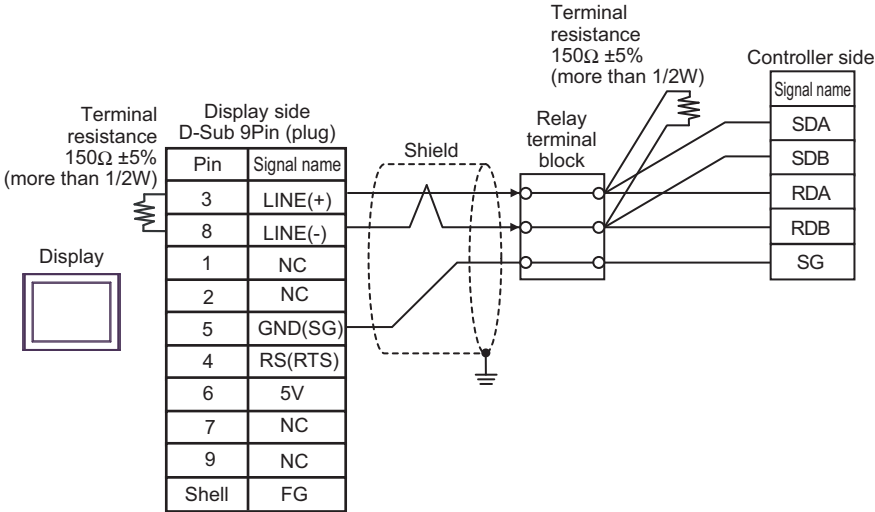

- 1:n Connection (Display is end of network)

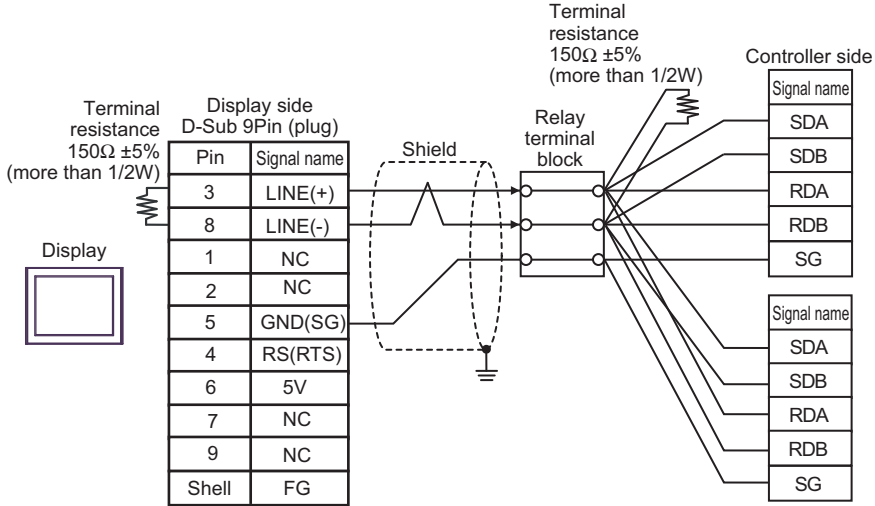

- 1:n Connection (Display is middle of network)

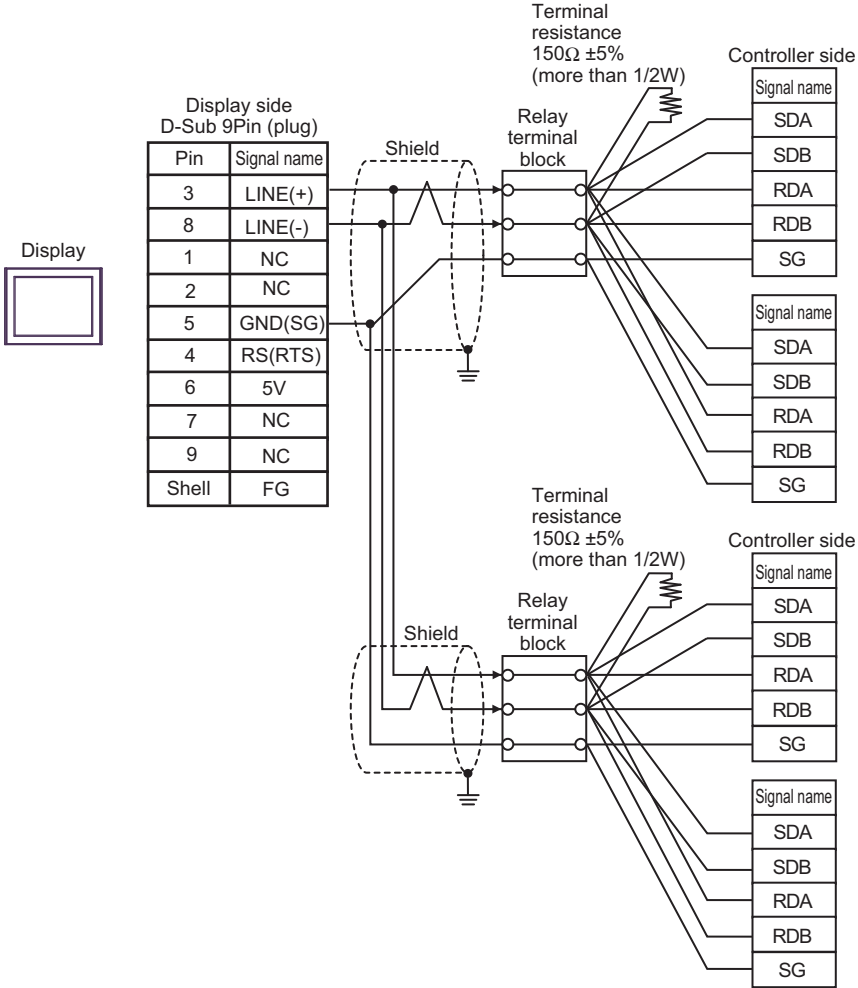

-
- IMPORTANT** • The 5V output (Pin #6) on the Display is the power for the Siemens AG's PROFIBUS connector. Do not use it for other devices.
-
- NOTE** • In COM on the GP-4107, the SG and FG terminals are isolated.
-

10I)

- 1:1 Connection

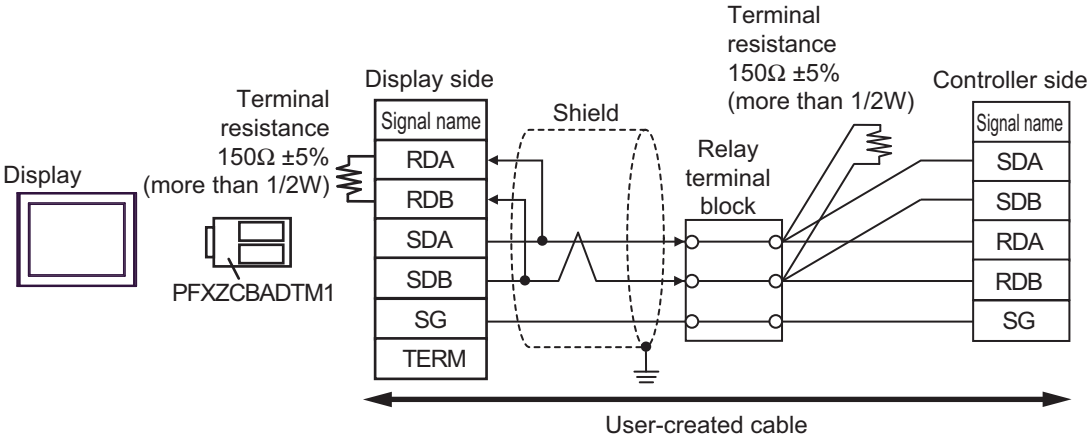

- 1:n Connection (Display is end of network)

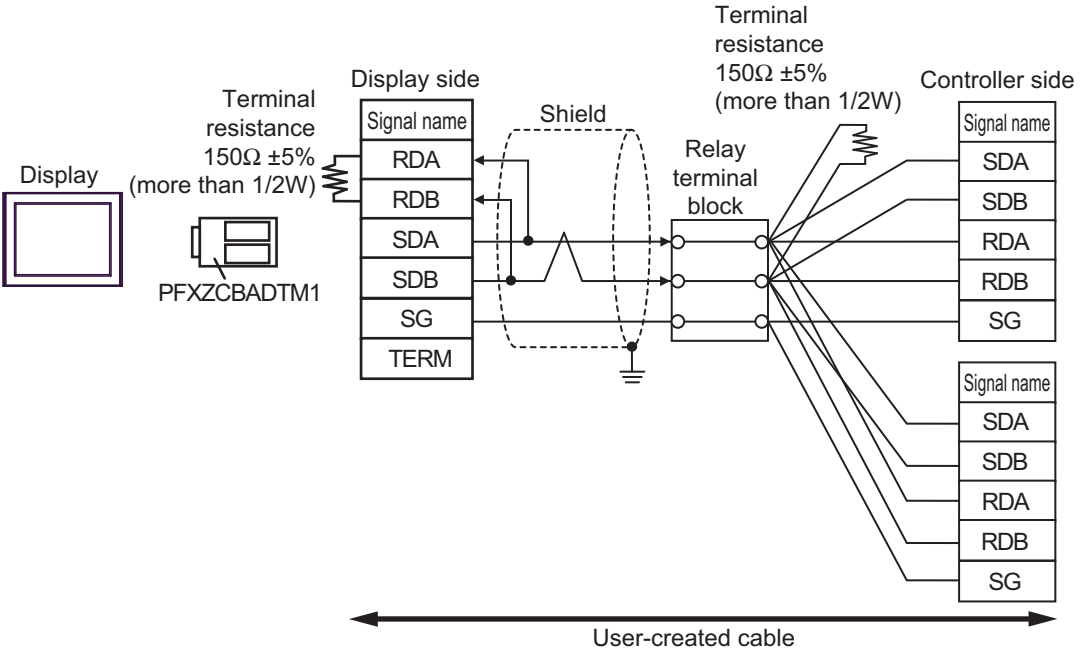

- 1:n Connection (Display is middle of network)

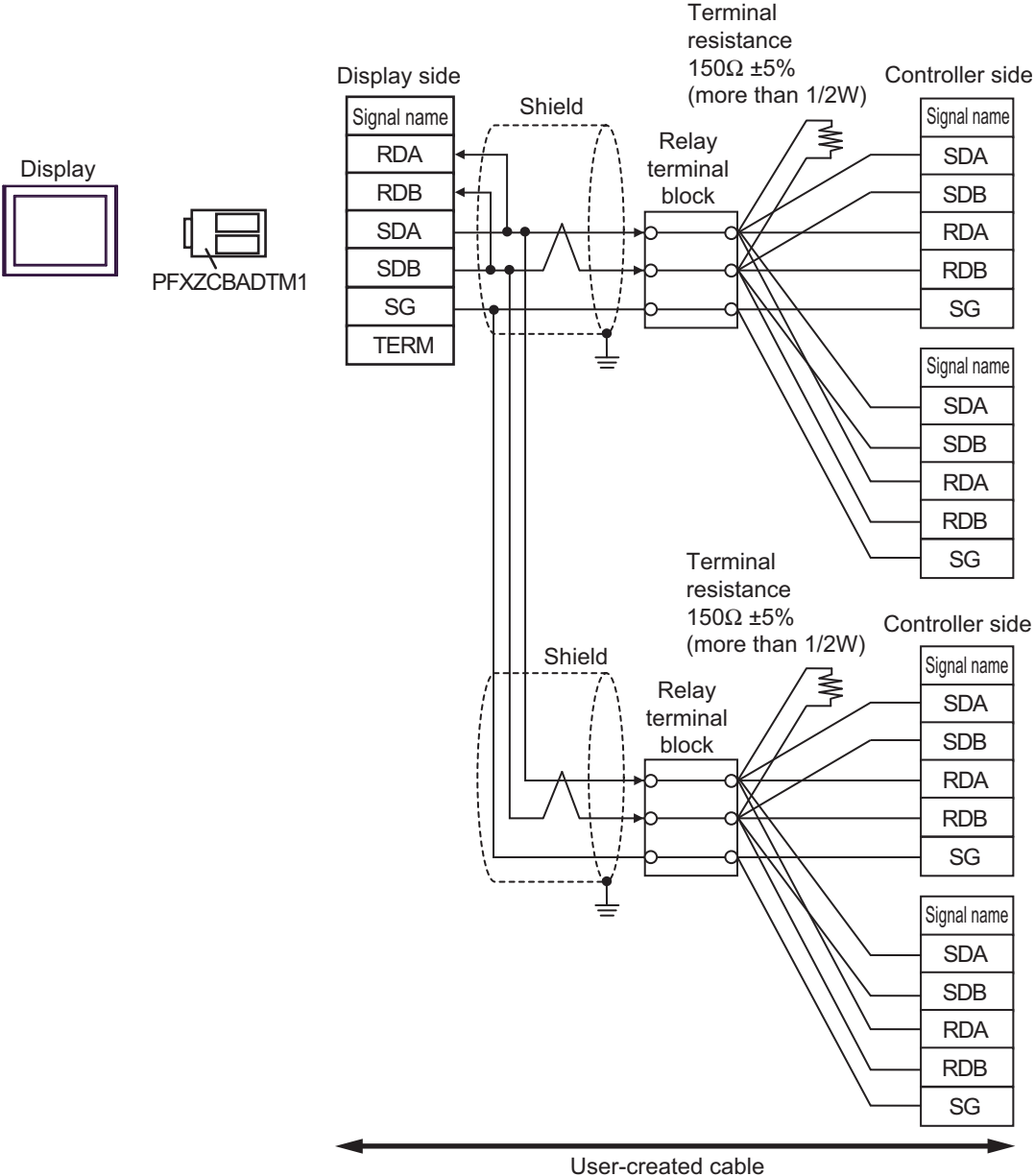

10J)

- 1:1 Connection

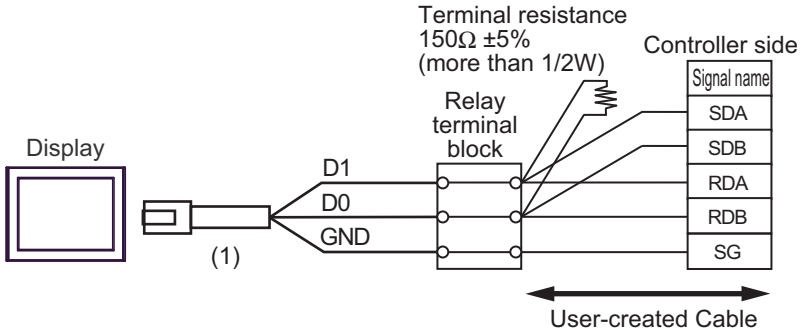

- 1:n Connection (Display is end of network)

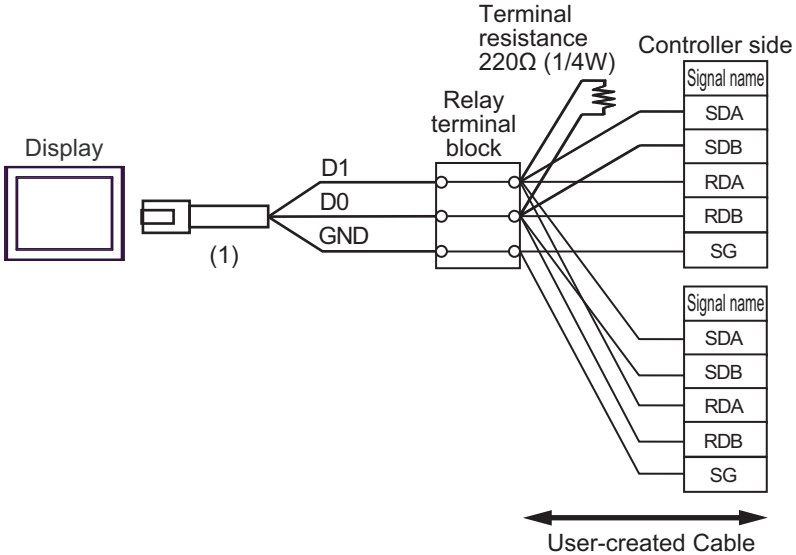

- 1:n Connection (Display is middle of network)

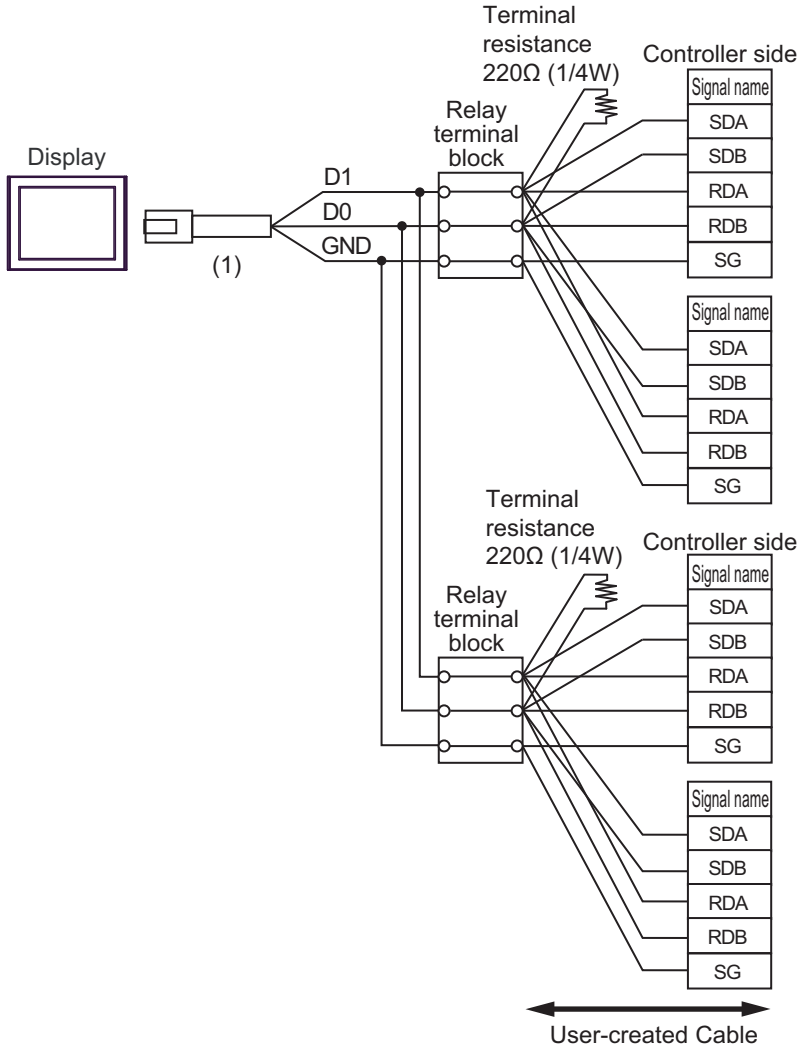

Number	Name	Notes
(1)	RJ45 RS-485 Cable (5m) by Pro-face PFXZLMCBRJ81	

10K)

- 1:1 Connection

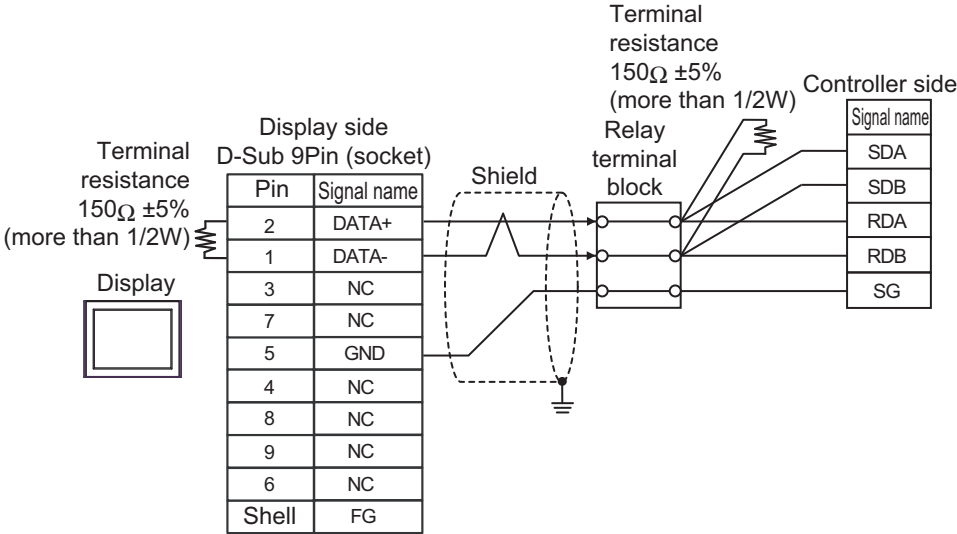

- 1:n Connection (Display is end of network)

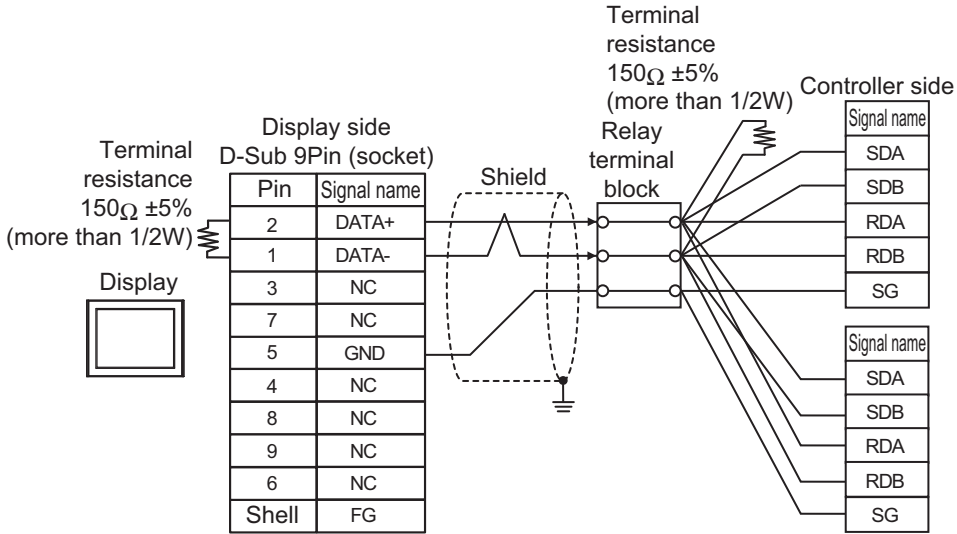

- 1:n Connection (Display is middle of network)

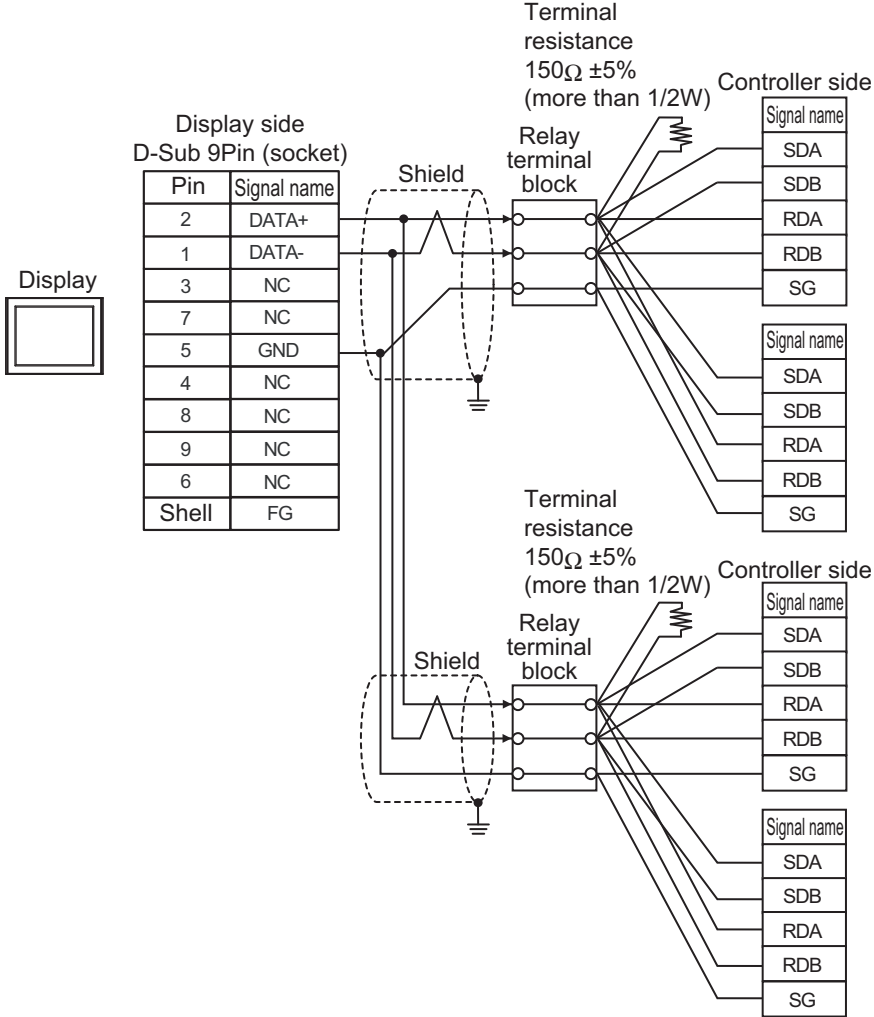

Cable Diagram 11

Display (Connection Port)	Cable		Remarks
GP3000* ¹ (COM1) AGP-3302B (COM2) GP-4*01TM (COM1) GP-Rear Module (COM1) ST3000* ² (COM2) LT3000 (COM1)	11A	COM port conversion adapter by Pro-face. CA3-ADPCOM-01 + Connector terminal block conversion adapter by Pro-face CA3-ADPTRM-01 + User-created cable	Cable length: 500m or less
	11B	User-created cable	
GP3000* ³ (COM2)	11C	Online adapter by Pro-face CA4-ADPONL-01 + Connector terminal block conversion adapter by Pro-face CA3-ADPTRM-01 + User-created cable	Cable length: 500m or less
	11D	Online adapter by Pro-face CA4-ADPONL-01 + User-created cable	
IPC* ⁴	11E	COM port conversion adapter by Pro-face. CA3-ADPCOM-01 + Connector terminal block conversion adapter by Pro-face CA3-ADPTRM-01 + User-created cable	Cable length: 500m or less
	11F	User-created cable	
GP-4106 (COM1) GP-4116T (COM1)	11G	User-created cable	Cable length: 500m or less
GP-4107 (COM1) GP-4*03T* ⁵ (COM2) GP-4203T (COM1)	11H	User-created cable	Cable length: 500m or less
GP4000* ⁶ (COM2) GP-4201T (COM1) SP5000* ⁷ (COM1/2) SP-5B00 (COM2) ST6000* ⁸ (COM2) ST-6200 (COM1) STM6000 (COM1) STC6000 (COM1) ET6000* ⁹ (COM2) PS6000 (Basic Box) (COM1/2)	11I	RS-422 terminal block conversion adapter by Pro-face PFXZCBADTM1* ¹⁰ + User-created cable	Cable length: 500m or less
	11B	User-created cable	
LT-4*01TM (COM1) LT-Rear Module (COM1)	11J	RJ45 RS-485 Cable (5m) by Pro-face PFXZLMCBJR81	Cable length: 200m or less
PE-4000B* ¹¹ PS5000* ¹¹ PS6000 (Optional Interface)* ¹¹	11K	User-created cable	Cable length: 500m or less

*1 All GP3000 models except AGP-3302B

- *2 Except AST-3211A and AST-3302B
- *3 All GP3000 models except the GP-3200 Series and AGP-3302B
- *4 Available only with COM ports that support RS-422/485 (2wire). (Except PE-4000B, PS5000, and PS6000)
 ☞ ■ IPC COM Port (page 9)
- *5 Except GP-4203T
- *6 All GP4000 models except GP-4100 series, GP-4*01TM, GP-Rear Module, GP-4201T and GP-4*03T
- *7 Except SP-5B00
- *8 Except ST-6200
- *9 Due to the COM port specifications, flow control is not possible. Omit wiring the control pins on the Display side of the cable diagram.
- *10 When using a Terminal Block Conversion Adapter (CA3-ADPTRM-01) instead of the RS-422 Terminal Block Conversion Adapter, refer to Cable Diagram 11A.
- *11 Available only with COM ports that support RS-422/485 (2wire).
 ☞ ■ IPC COM Port (page 9)

11A)

- 1:1 Connection

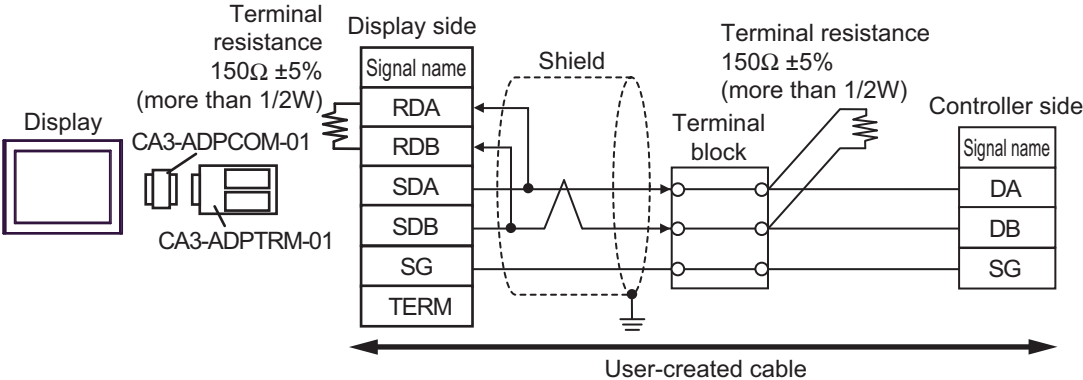

- 1:n Connection (Display is end of network)

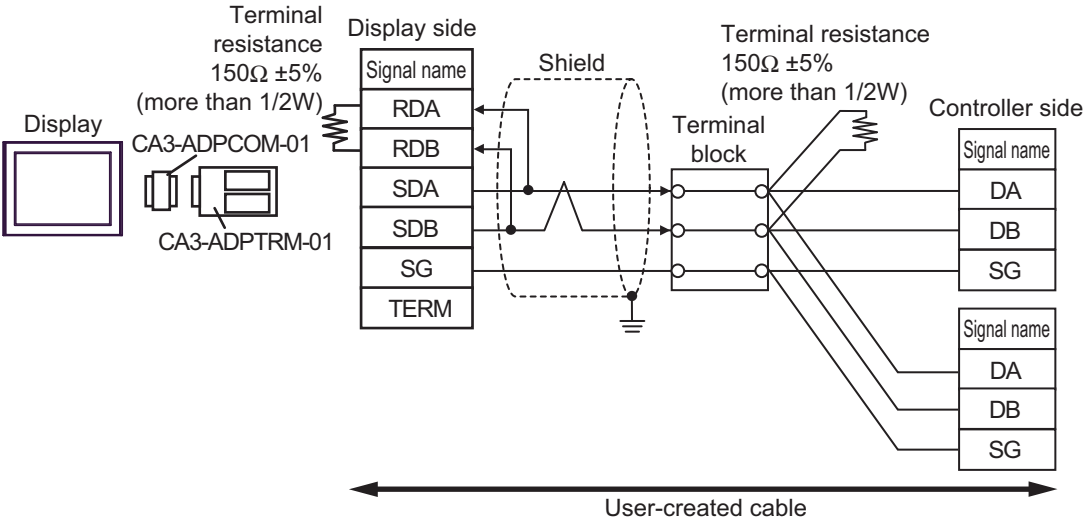

- 1:n Connection (Display is middle of network)

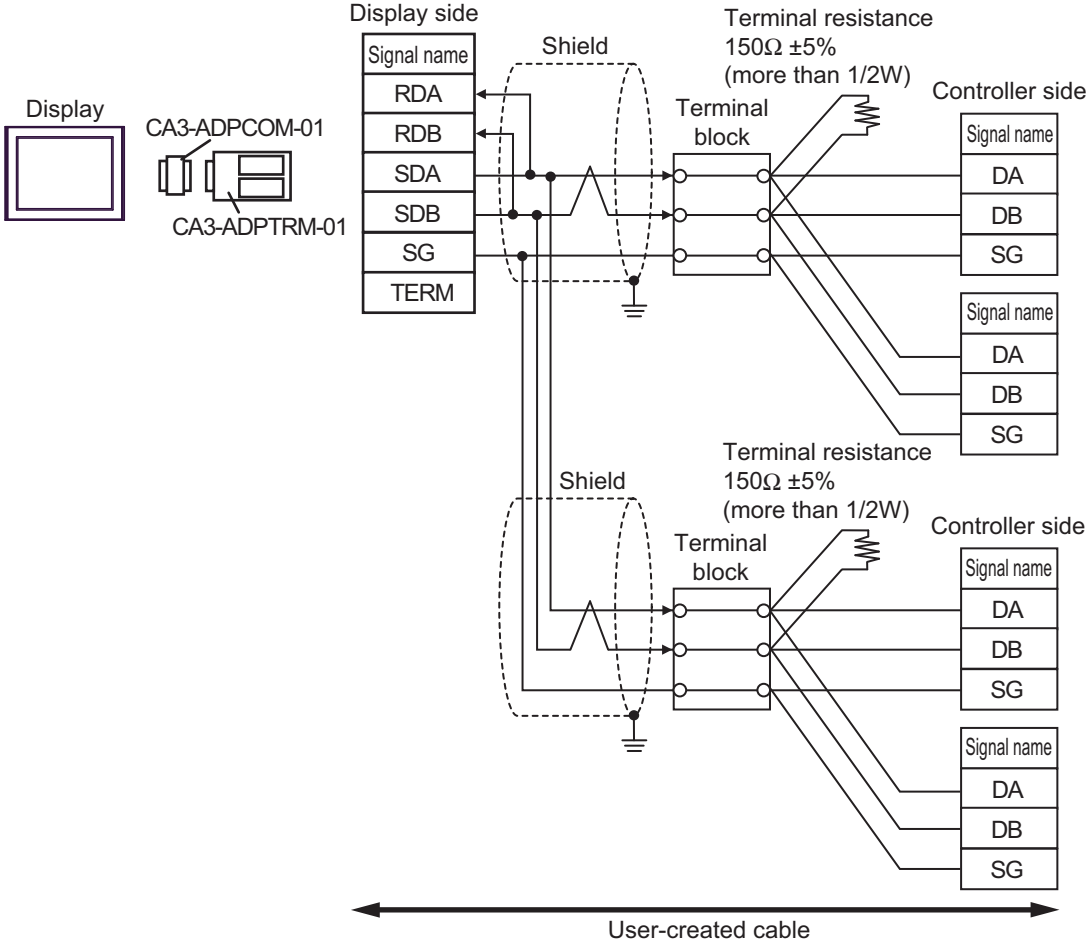

11B)

- 1:1 Connection

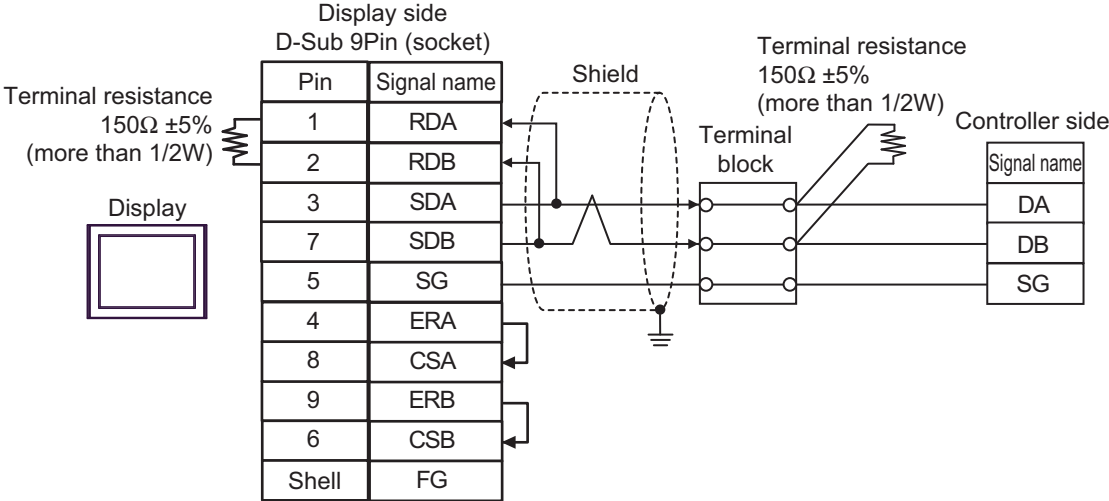

- 1:n Connection (Display is end of network)

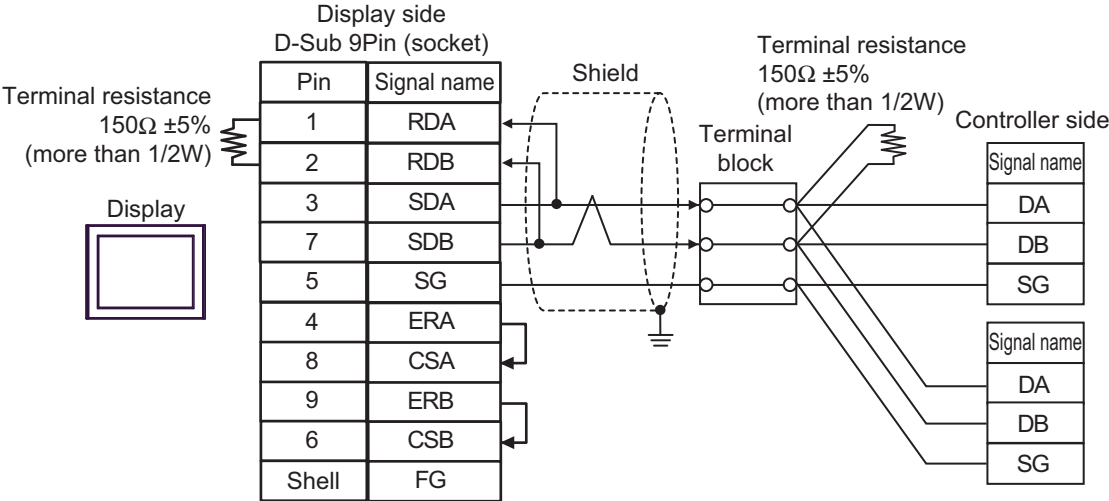

- 1:n Connection (Display is middle of network)

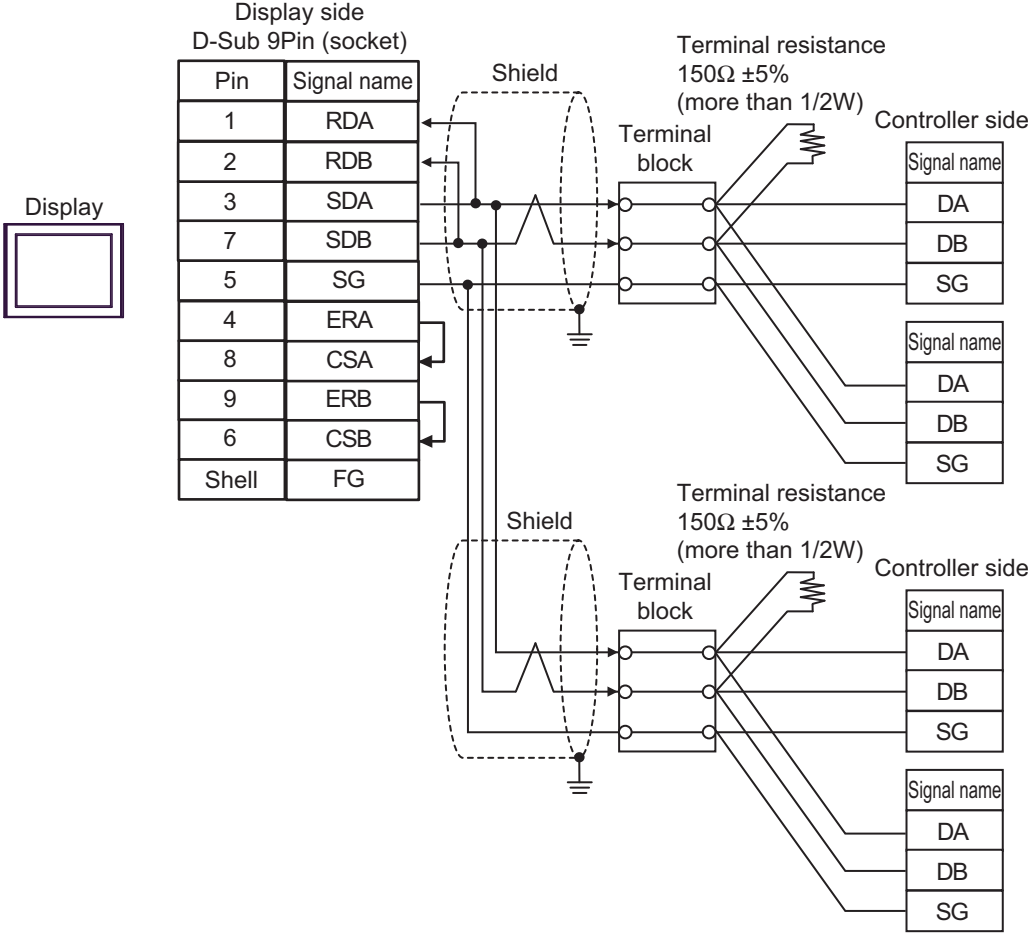

11C)

- 1:1 Connection

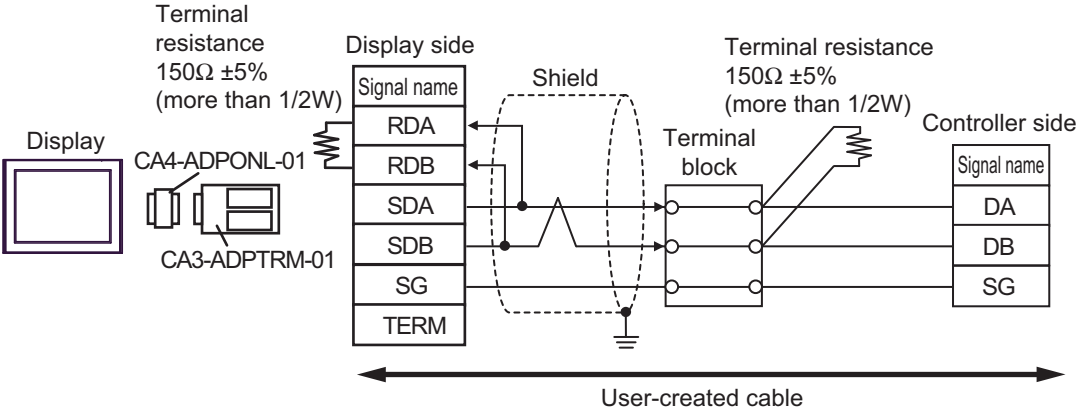

- 1:n Connection (Display is end of network)

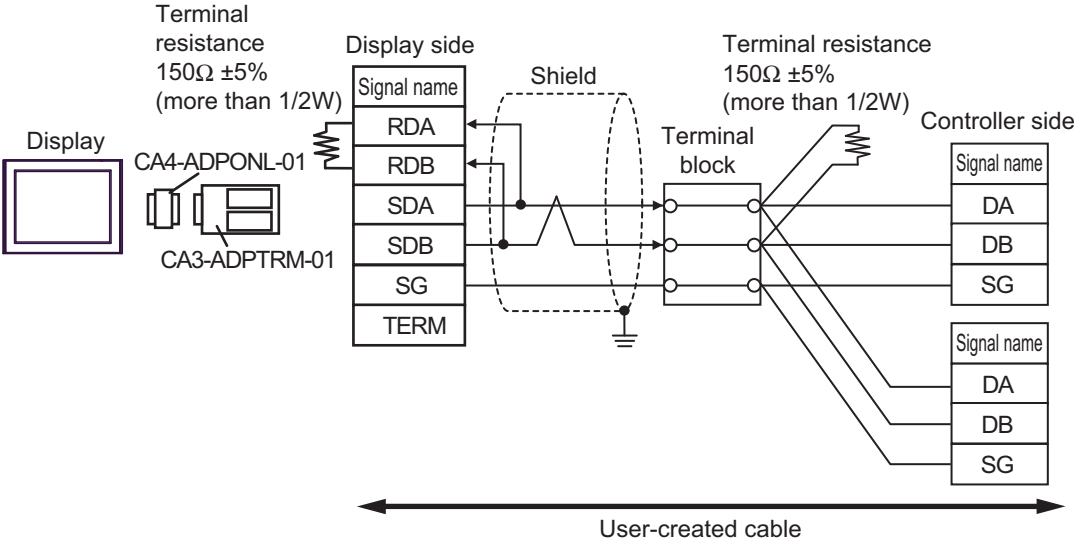

- 1:n Connection (Display is middle of network)

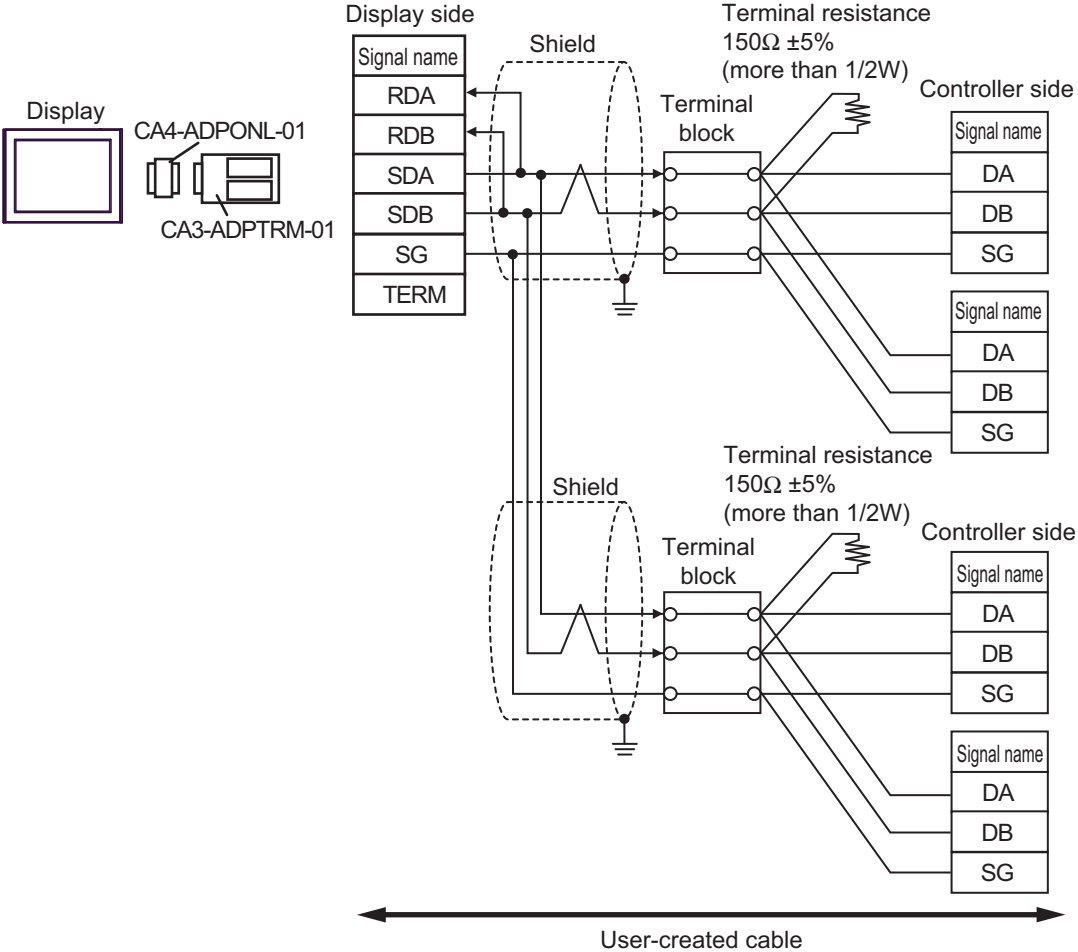

11D)

- 1:1 Connection

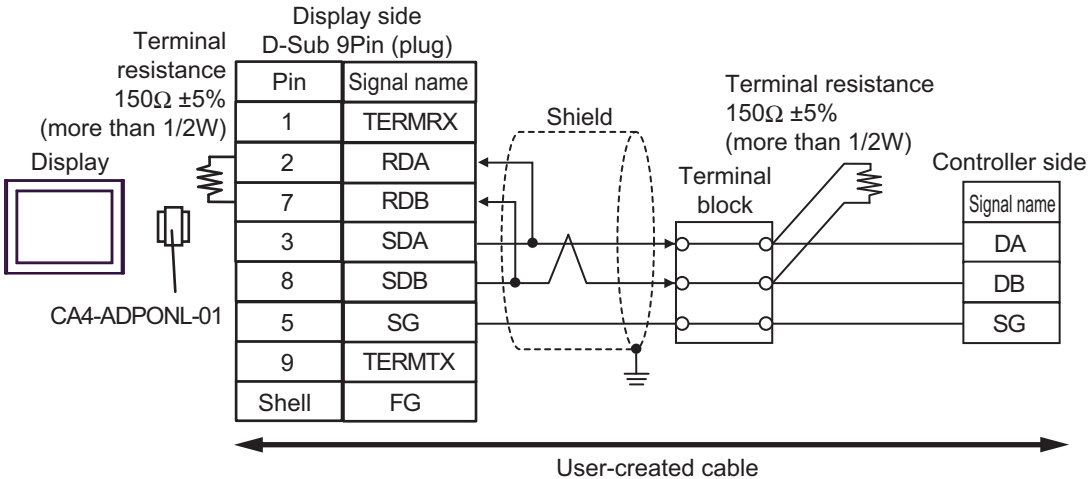

- 1:n Connection (Display is end of network)

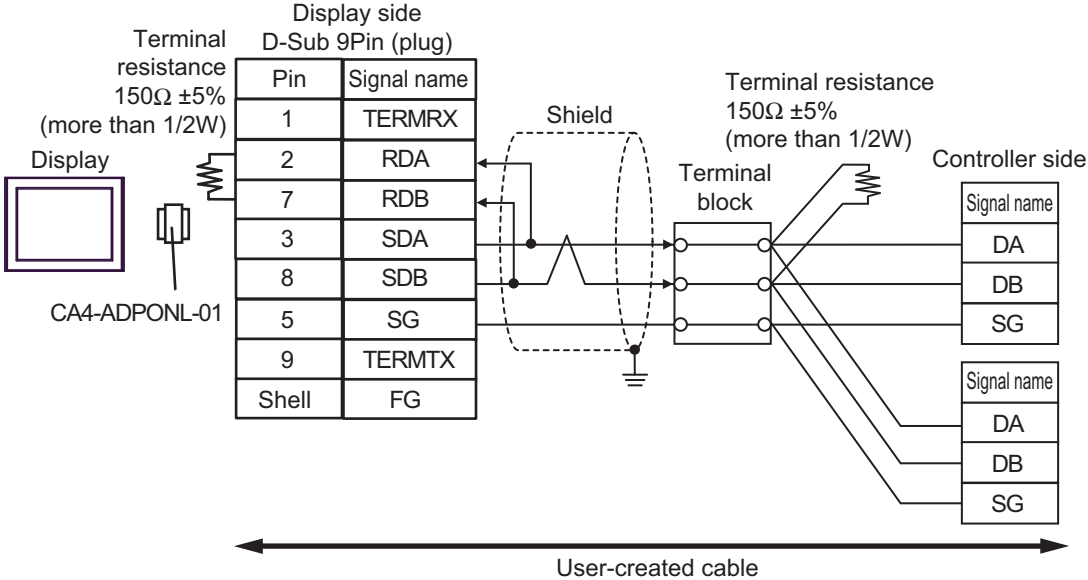

11E)

- 1:1 Connection

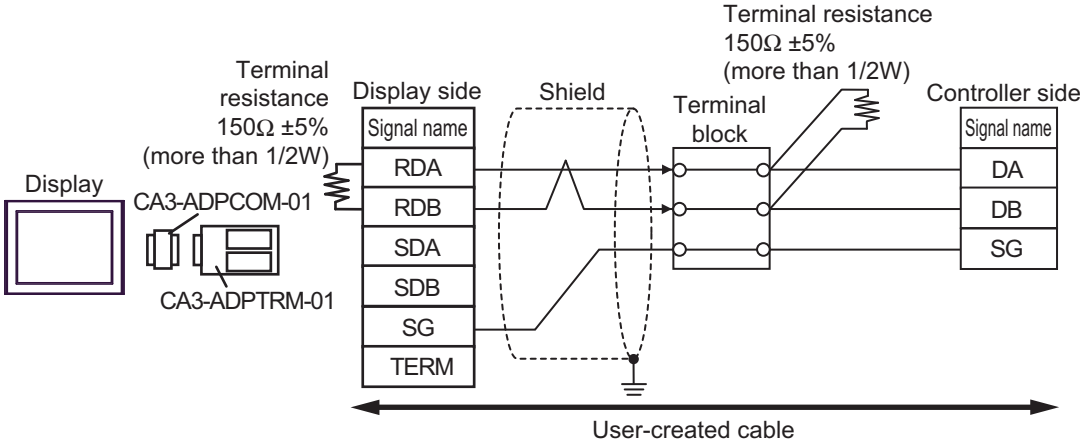

- 1:n Connection (Display is end of network)

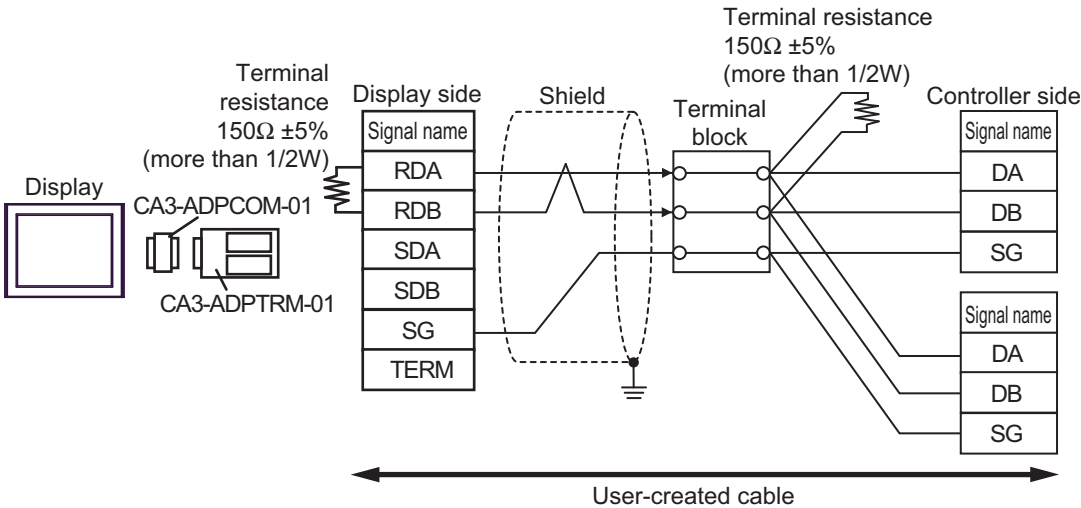

- 1:n Connection (Display is middle of network)

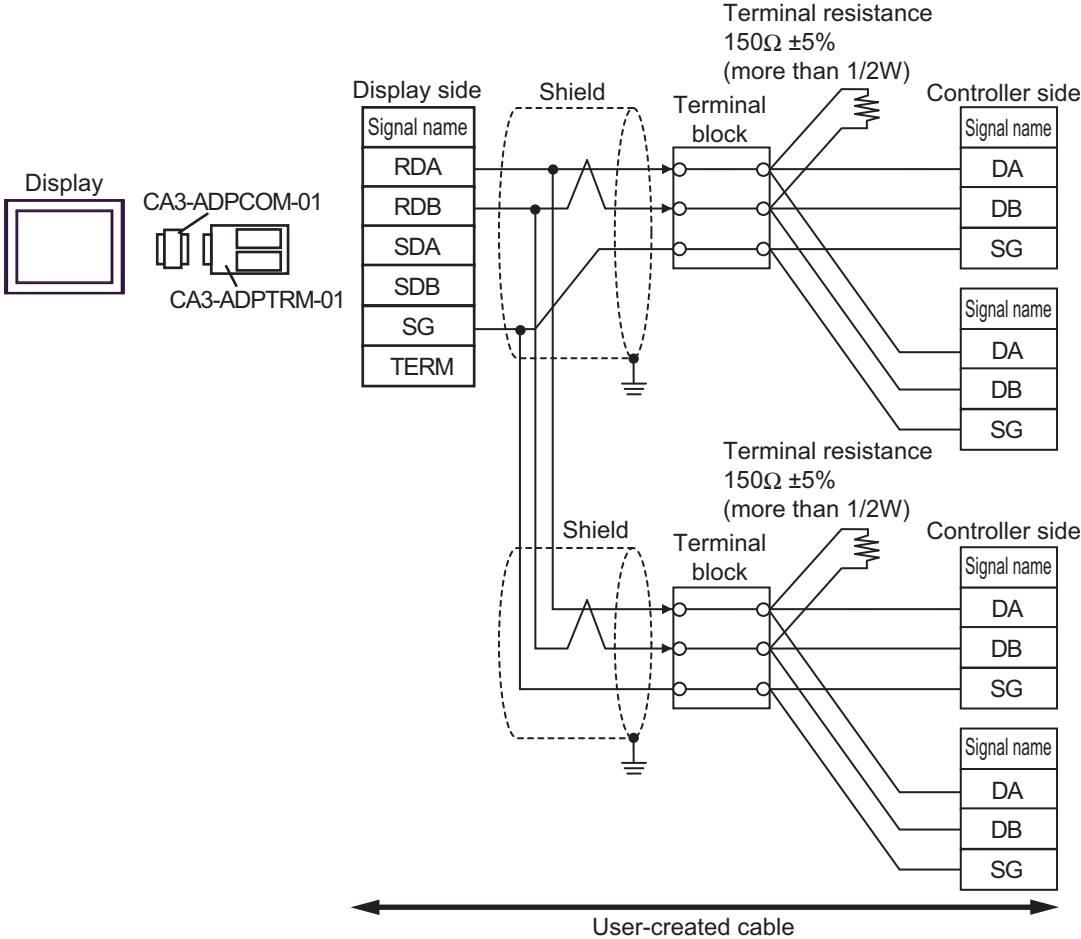

11F)

- 1:1 Connection

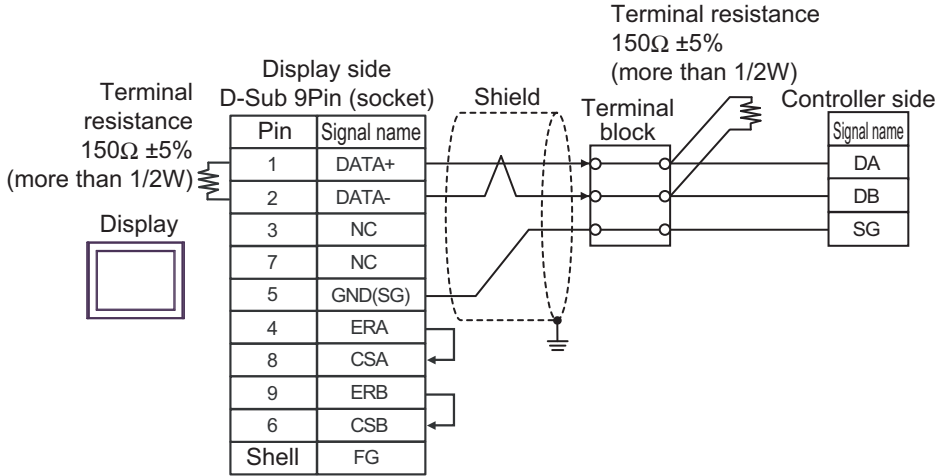

- 1:n Connection (Display is end of network)

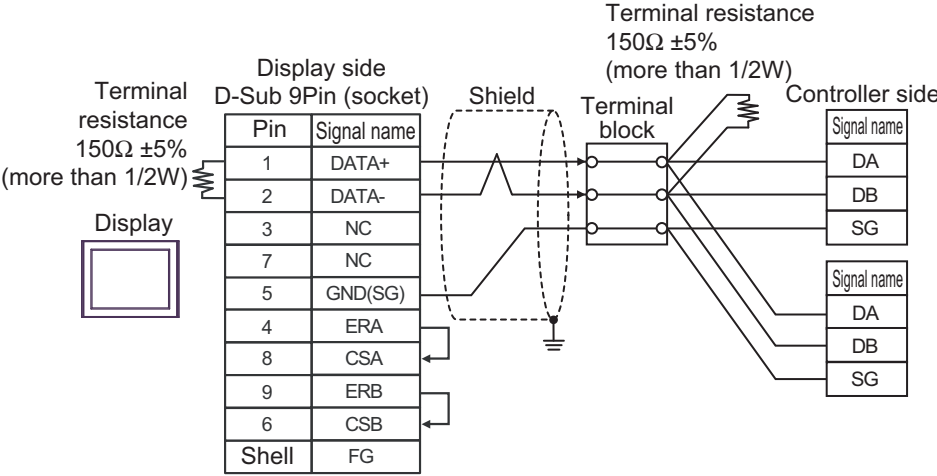

- 1:n Connection (Display is middle of network)

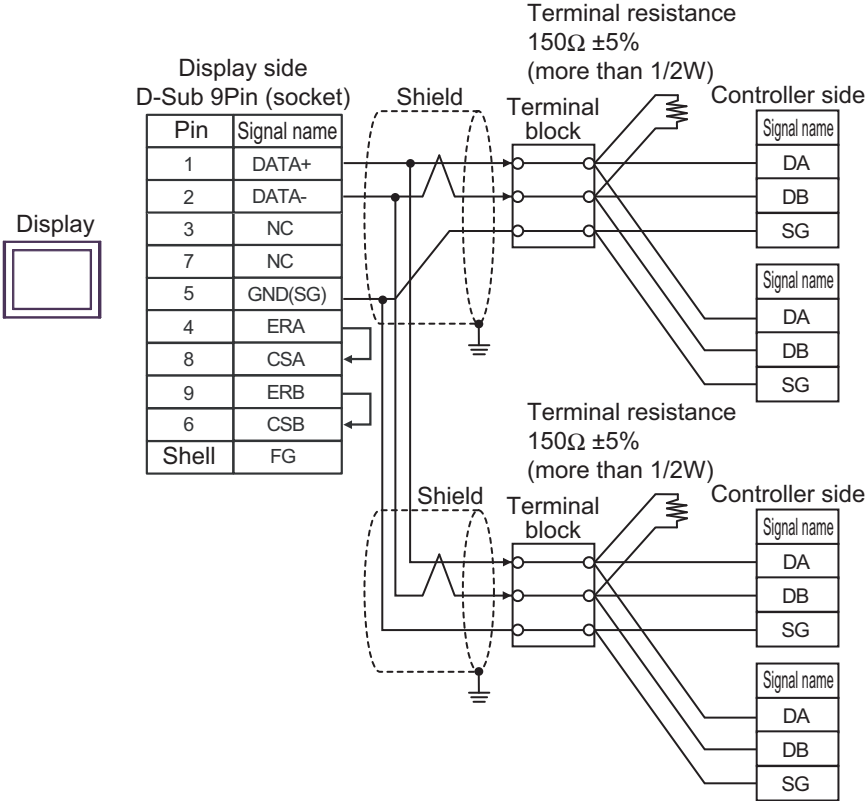

11G)

- 1:1 Connection

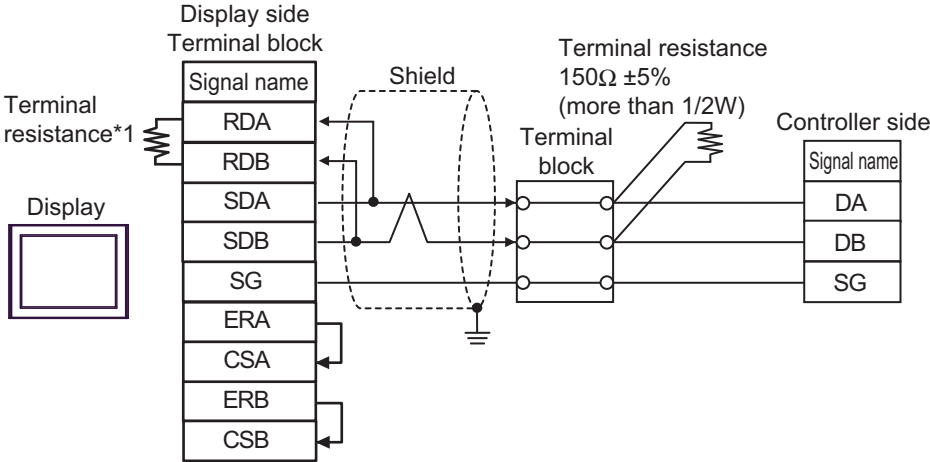

- 1:n Connection (Display is end of network)

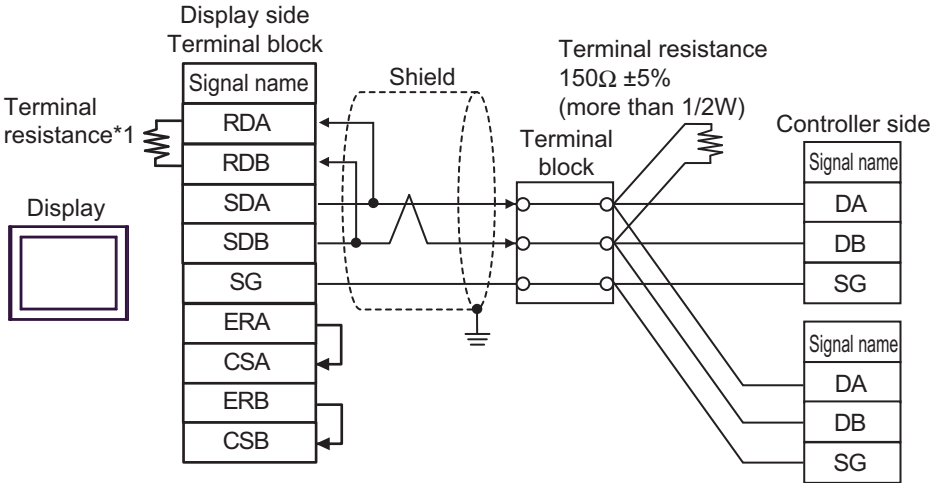

*1 The resistance in the Display is used as the termination resistance. Set the value of the DIP Switch on the rear of the Display as shown in the table below.

DIP Switch No.	Set Value
1	OFF
2	OFF
3	ON
4	ON

- 1:n Connection (Display is middle of network)

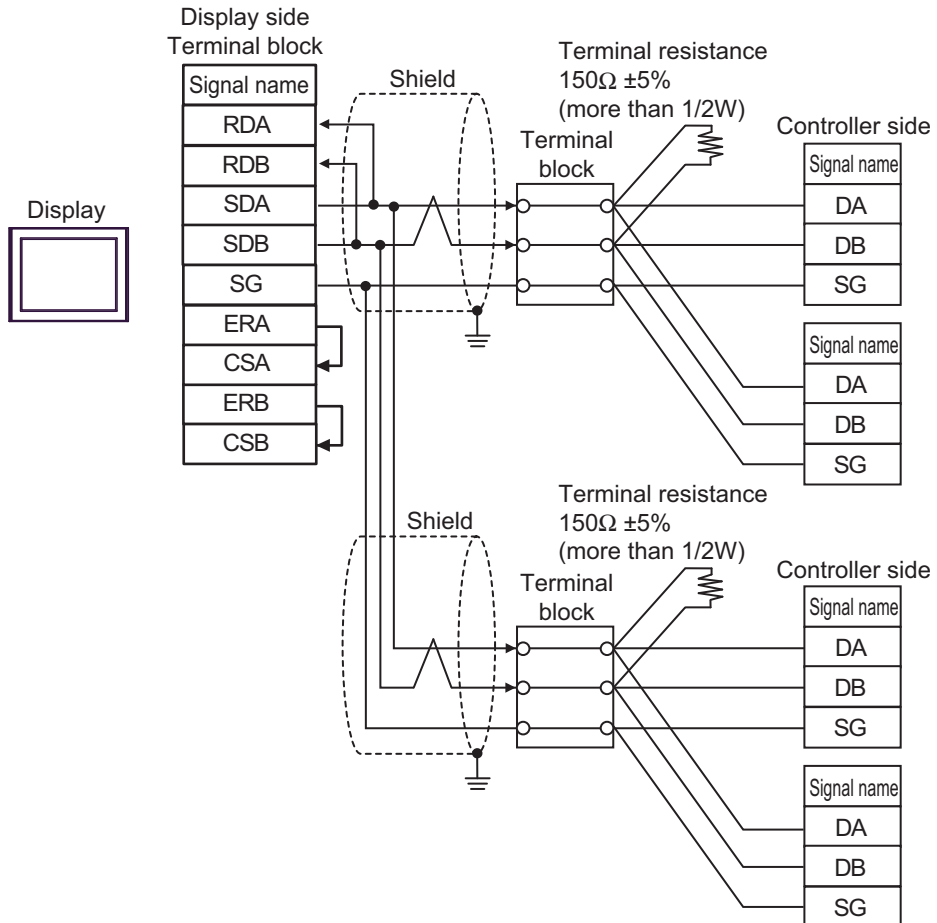
**IMPORTANT**

- Set the DIP Switch 1-4 on the rear of the Display to OFF.

11H)

- 1:1 Connection

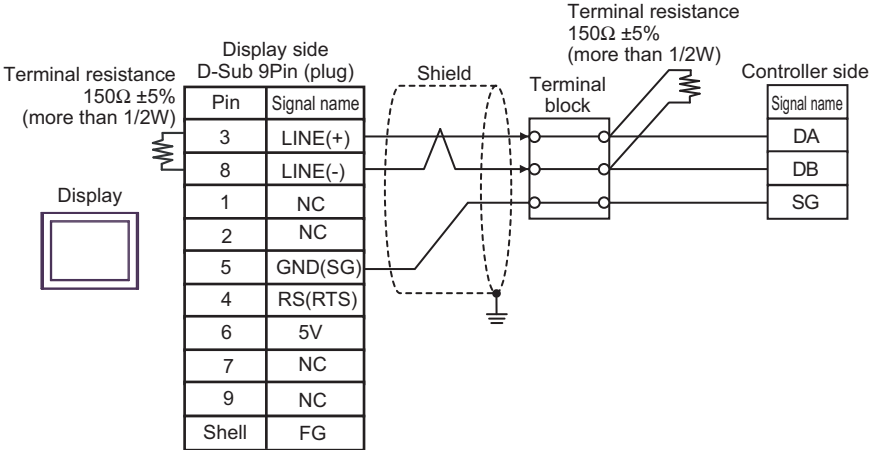

- 1:n Connection (Display is end of network)

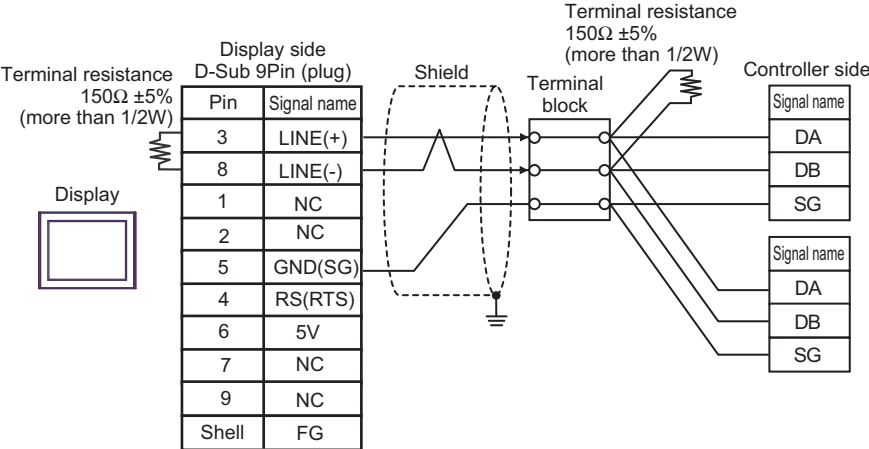

- 1:n Connection (Display is middle of network)

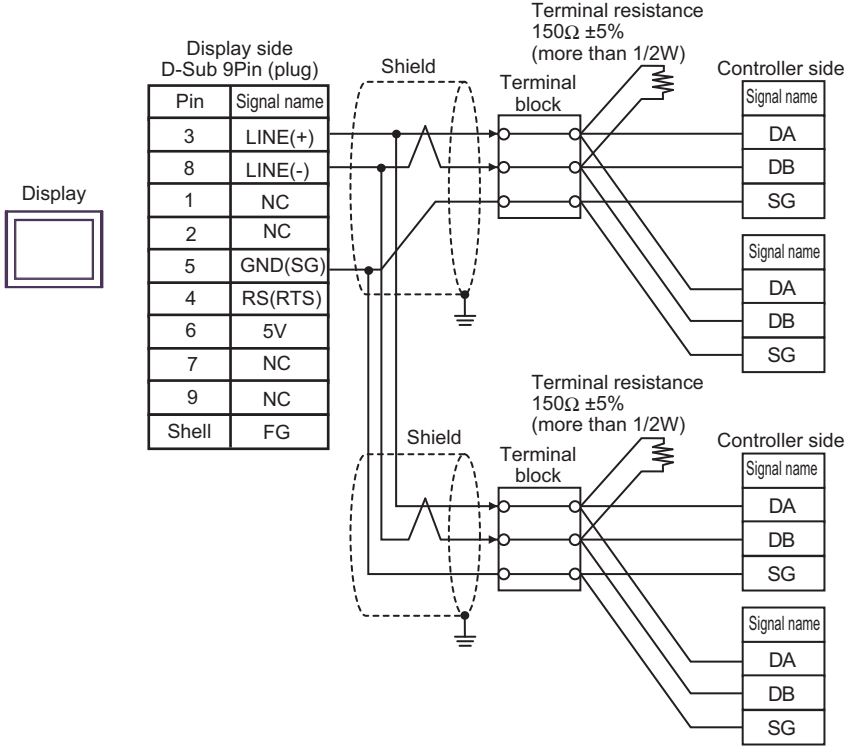

IMPORTANT • The 5V output (Pin #6) on the Display is the power for the Siemens AG's PROFIBUS connector. Do not use it for other devices.

NOTE • In COM on the GP-4107, the SG and FG terminals are isolated.

111)

- 1:1 Connection

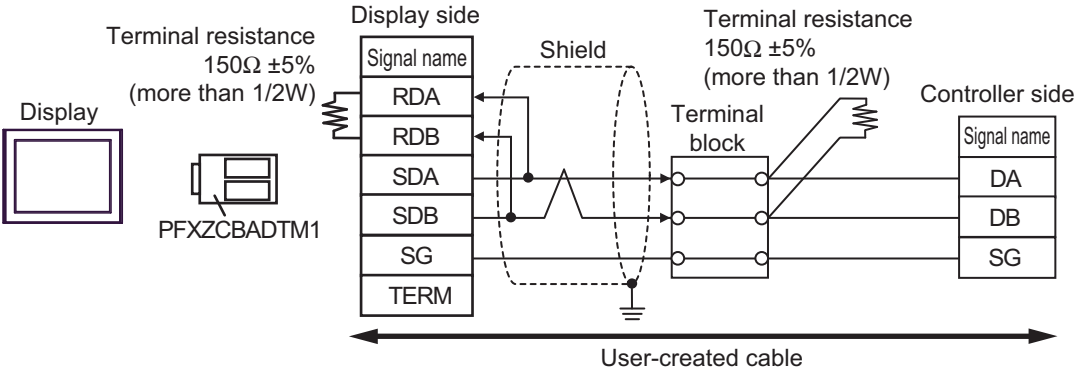

- 1:n Connection (Display is end of network)

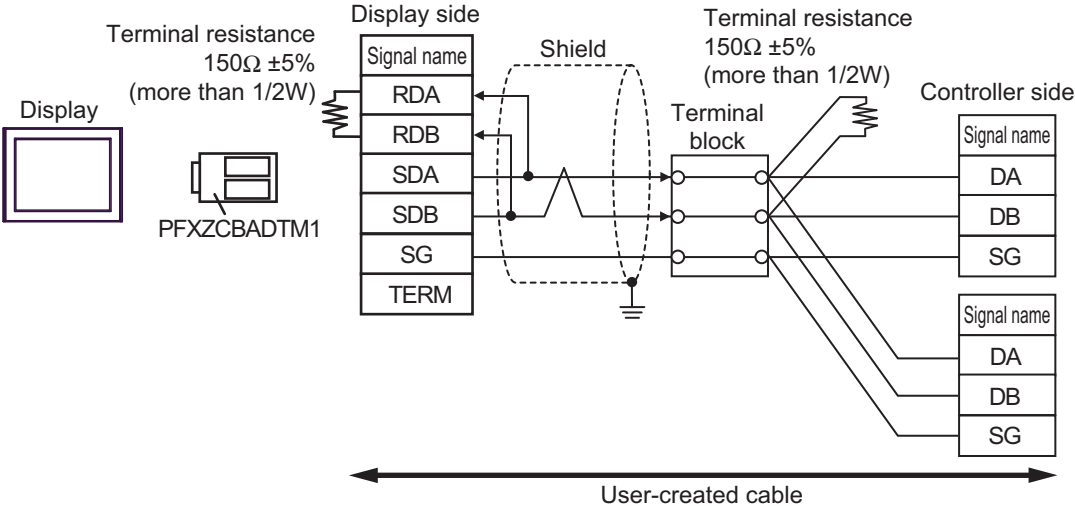

- 1:n Connection (Display is middle of network)

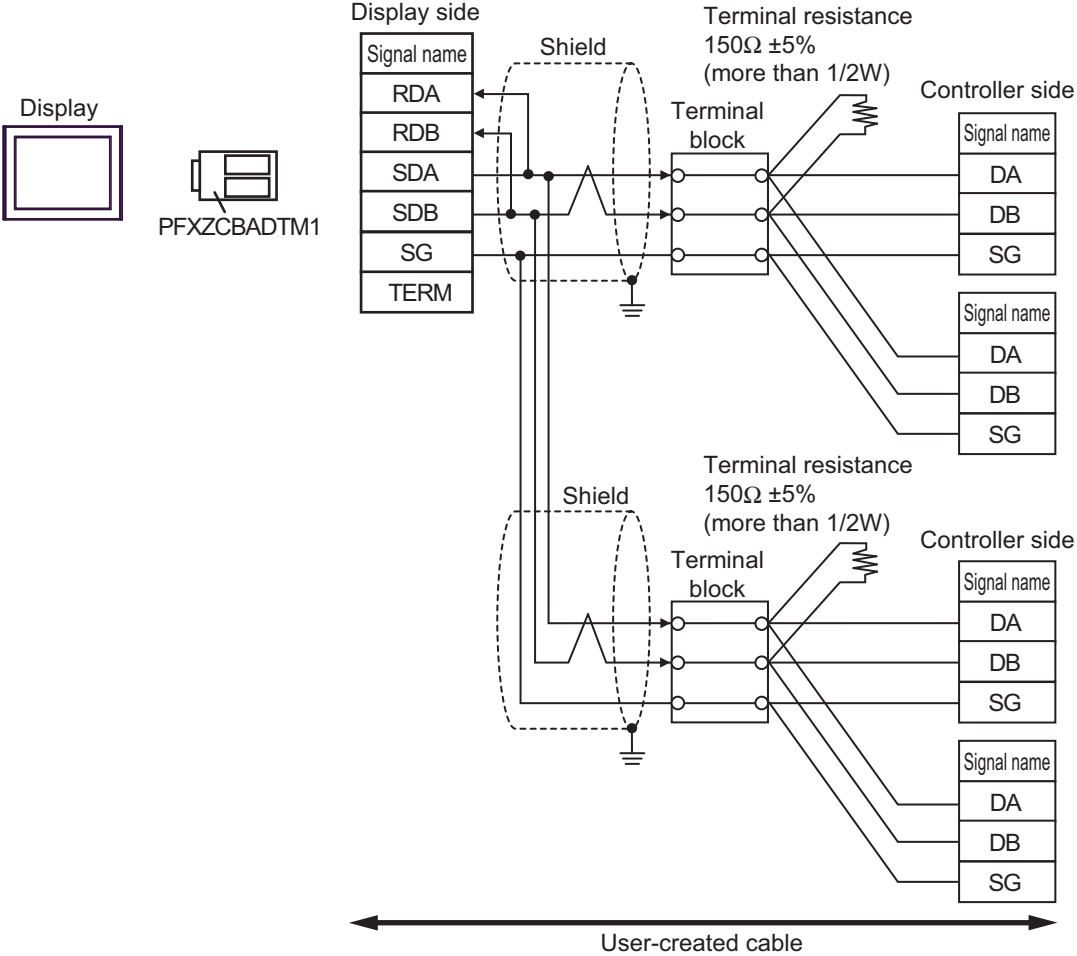

11J)

- 1:1 Connection

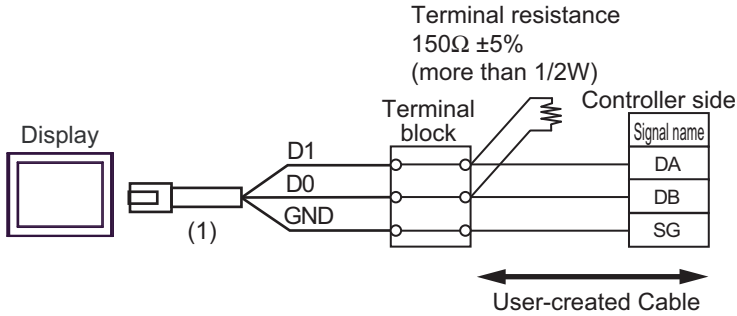

- 1:n Connection (Display is end of network)

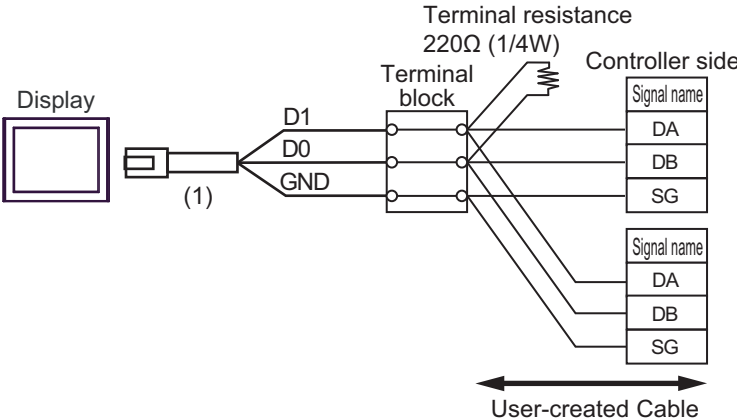

- 1:n Connection (Display is middle of network)

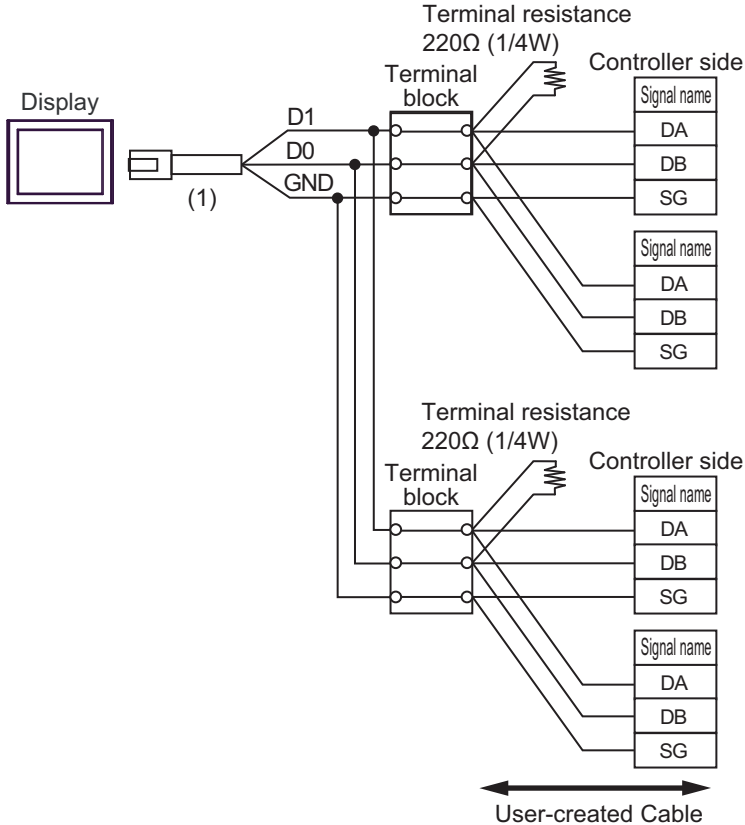

Number	Name	Notes
(1)	RJ45 RS-485 Cable (5m) by Pro-face PFXZLMCBJR81	

11K)

- 1:1 Connection

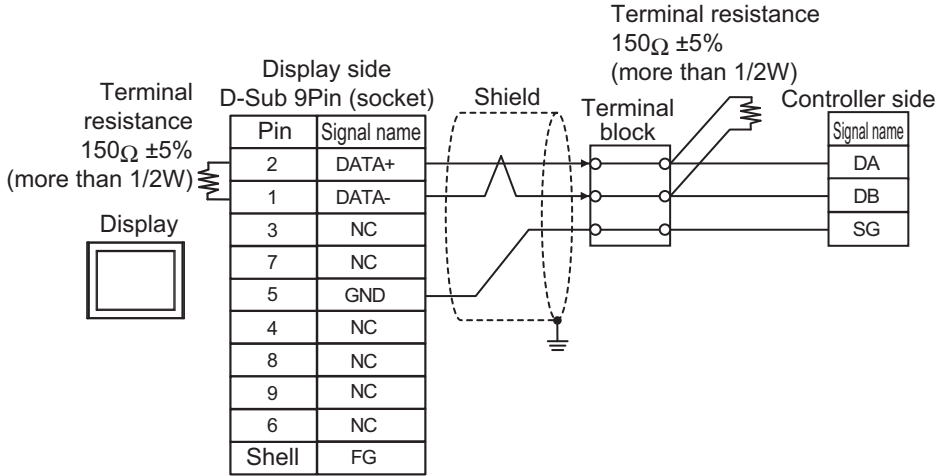

- 1:n Connection (Display is end of network)

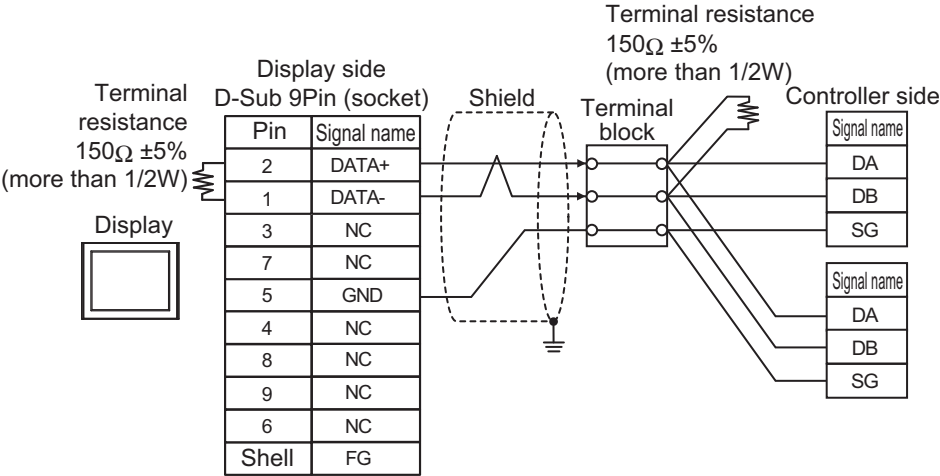

- 1:n Connection (Display is middle of network)

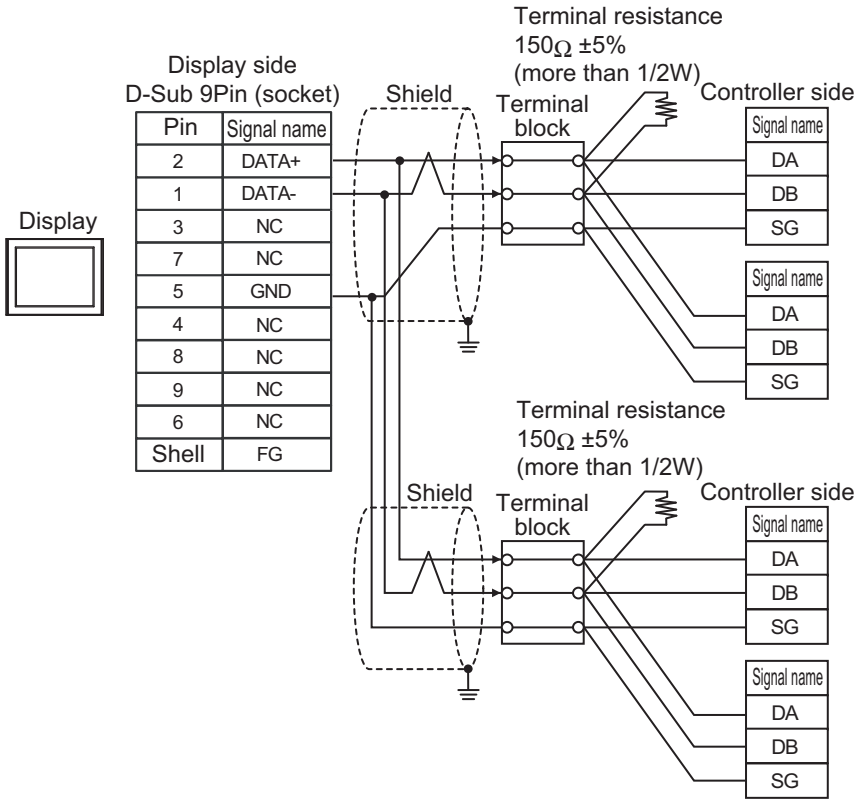

Cable Diagram 12

Display (Connection Port)	Cable		Remarks
GP-4401 (COM2)	12A	RS-422 terminal block conversion adapter by Pro-face PFXZCBADTM1 + User-created cable	Cable length: 500m or less
	12B	User-created cable	

12A)

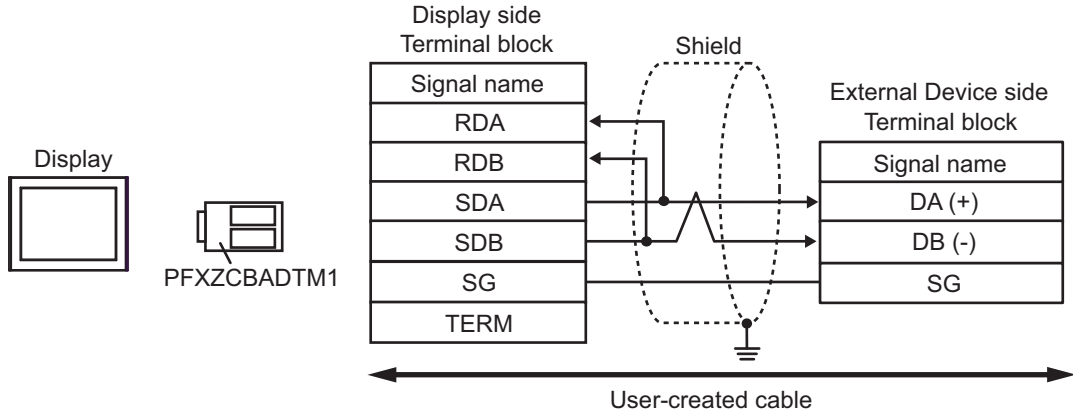

NOTE

- No termination resistor is required.

12B)

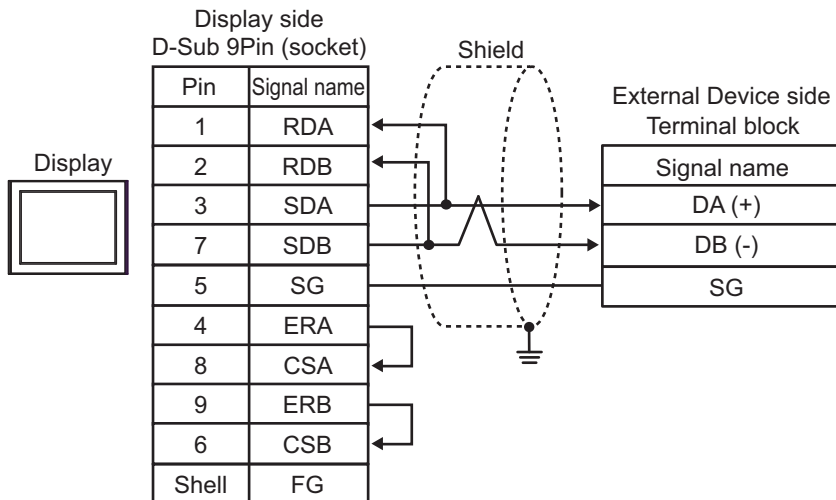

NOTE

- No termination resistor is required.

6 Supported Devices

The following table shows the range of supported device addresses. Note that the actually supported range varies depending on the External Device to be used. Please check the actual range in your External Device manual.

Enter the External Device address in the dialog box below.

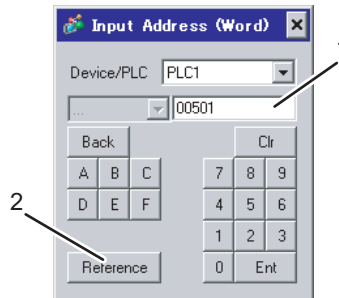

1. Address
2. Browse

Enter the address.

A list of available parameters is displayed.

Click the parameter you want to use, and press "Select" to enter the address.

6.1 SDC10

 : This address can be specified as system data area.

Device	Bit Address	Word Address	32 bits	Remarks
Data	00501.0-04504.F	00501-04504	[L/H]	*1

*1 When bits are written, the Display reads the corresponding word address from the External Device, sets particular bits of that word address to ON, and then returns the resulting address to the External Device. Note that the correct data may not be written if you change the word address using the ladder program while the Display reads data from the External Device and returns it.

IMPORTANT

- Setting [Enable System Data Area] in the system area setting of GP-Pro EX may cause malfunction. Do not set [Enable System Data Area].

NOTE

- You can set only the reading area size in the Controller's system area setting. Refer to the GP-Pro EX Reference Manual for the reading area size.

Cf. GP-Pro EX Reference Manual "LS Area (only for direct access method Area)"



- Refer to the precautions on manual notation for icons in the table.

"Manual Symbols and Terminology"

- Even if you use a nonexistent address, the read error may not be displayed. In this case, "0" is retained for the read data. Note that the write error is displayed.

6.2 SDC15/SDC25/SDC26/SDC35/SDC36

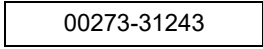
 : This address can be specified as system data area.

Device	Bit Address	Word Address	32 bits	Remarks
Data	00273.0-31243.F	 00273-31243		*1

*1 When bits are written, the Display reads the corresponding word address from the External Device, sets particular bits of that word address to ON, and then returns the resulting address to the External Device. Note that the correct data may not be written if you change the word address using the ladder program while the Display reads data from the External Device and returns it.

IMPORTANT

- Setting [Enable System Data Area] in the system area setting of GP-Pro EX may cause malfunction. Do not set [Enable System Data Area].

NOTE

- You can set only the reading area size in the Controller's system area setting. Refer to the GP-Pro EX Reference Manual for the reading area size.

Cf. GP-Pro EX Reference Manual "LS Area (only for direct access method Area)"



- Refer to the precautions on manual notation for icons in the table.

 "Manual Symbols and Terminology"

- Even if you use a nonexistent address, the read error may not be displayed. In this case, "0" is retained for the read data. Note that the write error is displayed.

6.3 SDC20/SDC21

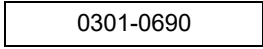
 : This address can be specified as system data area.

Device	Bit Address	Word Address	32 bits	Remarks
Data	0301.0-0690.F	 0301-0690		*1

*1 When bits are written, the Display reads the corresponding word address from the External Device, sets particular bits of that word address to ON, and then returns the resulting address to the External Device. Note that the correct data may not be written if you change the word address using the ladder program while the Display reads data from the External Device and returns it.

IMPORTANT

- Setting [Enable System Data Area] in the system area setting of GP-Pro EX may cause malfunction. Do not set [Enable System Data Area].

NOTE

- You can set only the reading area size in the Controller's system area setting. Refer to the GP-Pro EX Reference Manual for the reading area size.

Cf. GP-Pro EX Reference Manual "LS Area (only for direct access method Area)"



- Refer to the precautions on manual notation for icons in the table.

 "Manual Symbols and Terminology"

- Even if you use a nonexistent address, the read error may not be displayed. In this case, "0" is retained for the read data. Note that the write error is displayed.

6.4 SDC30/SDC31

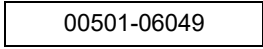
 : This address can be specified as system data area.

Device	Bit Address	Word Address	32 bits	Remarks
Data	00501.0-06049.F	 00501-06049		*1

*1 When bits are written, the Display reads the corresponding word address from the External Device, sets particular bits of that word address to ON, and then returns the resulting address to the External Device. Note that the correct data may not be written if you change the word address using the ladder program while the Display reads data from the External Device and returns it.

IMPORTANT

- Setting [Enable System Data Area] in the system area setting of GP-Pro EX may cause malfunction. Do not set [Enable System Data Area].

NOTE

- You can set only the reading area size in the Controller's system area setting. Refer to the GP-Pro EX Reference Manual for the reading area size.

Cf. GP-Pro EX Reference Manual "LS Area (only for direct access method Area)"



- Refer to the precautions on manual notation for icons in the table.

 "Manual Symbols and Terminology"

- Even if you use a nonexistent address, the read error may not be displayed. In this case, "0" is retained for the read data. Note that the write error is displayed.

6.5 SDC40A

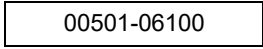
 : This address can be specified as system data area.

Device	Bit Address	Word Address	32 bits	Remarks
Data	00501.0-06100.F	 00501-06100		*1

*1 When bits are written, the Display reads the corresponding word address from the External Device, sets particular bits of that word address to ON, and then returns the resulting address to the External Device. Note that the correct data may not be written if you change the word address using the ladder program while the Display reads data from the External Device and returns it.

IMPORTANT

- Setting [Enable System Data Area] in the system area setting of GP-Pro EX may cause malfunction. Do not set [Enable System Data Area].

NOTE

- You can set only the reading area size in the Controller's system area setting. Refer to the GP-Pro EX Reference Manual for the reading area size.

Cf. GP-Pro EX Reference Manual "LS Area (only for direct access method Area)"



- Refer to the precautions on manual notation for icons in the table.

 "Manual Symbols and Terminology"

- Even if you use a nonexistent address, the read error may not be displayed. In this case, "0" is retained for the read data. Note that the write error is displayed.

6.6 SDC40B

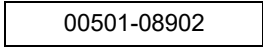
 : This address can be specified as system data area.

Device	Bit Address	Word Address	32 bits	Remarks
Data	00501.0-08902.F	 00501-08902		*1

*1 When bits are written, the Display reads the corresponding word address from the External Device, sets particular bits of that word address to ON, and then returns the resulting address to the External Device. Note that the correct data may not be written if you change the word address using the ladder program while the Display reads data from the External Device and returns it.

IMPORTANT

- Setting [Enable System Data Area] in the system area setting of GP-Pro EX may cause malfunction. Do not set [Enable System Data Area].

NOTE

- You can set only the reading area size in the Controller's system area setting. Refer to the GP-Pro EX Reference Manual for the reading area size.

Cf. GP-Pro EX Reference Manual "LS Area (only for direct access method Area)"



- Refer to the precautions on manual notation for icons in the table.

 "Manual Symbols and Terminology"

- Even if you use a nonexistent address, the read error may not be displayed. In this case, "0" is retained for the read data. Note that the write error is displayed.

6.7 SDC40G

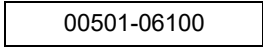
 : This address can be specified as system data area.

Device	Bit Address	Word Address	32 bits	Remarks
Data	00501.0-06100.F	 00501-06100		*1

*1 When bits are written, the Display reads the corresponding word address from the External Device, sets particular bits of that word address to ON, and then returns the resulting address to the External Device. Note that the correct data may not be written if you change the word address using the ladder program while the Display reads data from the External Device and returns it.

IMPORTANT

- Setting [Enable System Data Area] in the system area setting of GP-Pro EX may cause malfunction. Do not set [Enable System Data Area].

NOTE

- You can set only the reading area size in the Controller's system area setting. Refer to the GP-Pro EX Reference Manual for the reading area size.

Cf. GP-Pro EX Reference Manual "LS Area (only for direct access method Area)"



- Refer to the precautions on manual notation for icons in the table.

 "Manual Symbols and Terminology"

- Even if you use a nonexistent address, the read error may not be displayed. In this case, "0" is retained for the read data. Note that the write error is displayed.

6.8 SDC45/46

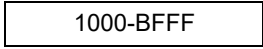
 : This address can be specified as system data area.

Device	Bit Address	Word Address	32 bits	Remarks
Data	1000.0-BFFF.F	 1000-BFFF		*1

*1 When bits are written, the Display reads the corresponding word address from the External Device, sets particular bits of that word address to ON, and then returns the resulting address to the External Device. Note that the correct data may not be written if you change the word address using the ladder program while the Display reads data from the External Device and returns it.

IMPORTANT

- Setting [Enable System Data Area] in the system area setting of GP-Pro EX may cause malfunction. Do not set [Enable System Data Area].

NOTE

- You can set only the reading area size in the Controller's system area setting. Refer to the GP-Pro EX Reference Manual for the reading area size.

Cf. GP-Pro EX Reference Manual "LS Area (only for direct access method Area)"



- Refer to the precautions on manual notation for icons in the table.

 "Manual Symbols and Terminology"

- Even if you use a nonexistent address, the read error may not be displayed. In this case, "0" is retained for the read data. Note that the write error is displayed.

6.9 DMC10

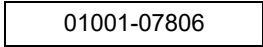
 : This address can be specified as system data area.

Device	Bit Address	Word Address	32 bits	Remarks
Data	01001.0-07806.F	 01001-07806		*1

*1 When bits are written, the Display reads the corresponding word address from the External Device, sets particular bits of that word address to ON, and then returns the resulting address to the External Device. Note that the correct data may not be written if you change the word address using the ladder program while the Display reads data from the External Device and returns it.

IMPORTANT

- Setting [Enable System Data Area] in the system area setting of GP-Pro EX may cause malfunction. Do not set [Enable System Data Area].

NOTE

- You can set only the reading area size in the Controller's system area setting. Refer to the GP-Pro EX Reference Manual for the reading area size.

Cf. GP-Pro EX Reference Manual "LS Area (only for direct access method Area)"



- Refer to the precautions on manual notation for icons in the table.

 "Manual Symbols and Terminology"

- Even if you use a nonexistent address, the read error may not be displayed. In this case, "0" is retained for the read data. Note that the write error is displayed.

6.10 DMC50

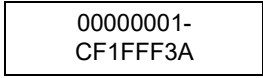
 : This address can be specified as system data area.

Device	Bit Address	Word Address	64 bits	Remarks
Data	00000001.00-CF1FFF3A.1F	 00000001- CF1FFF3A		*1

*1 When bits are written, the Display reads the corresponding word address from the External Device, sets particular bits of that word address to ON, and then returns the resulting address to the External Device. Note that the correct data may not be written if you change the word address using the ladder program while the Display reads data from the External Device and returns it.

IMPORTANT



- Setting [Enable System Data Area] in the system area setting of GP-Pro EX may cause malfunction. Do not set [Enable System Data Area].

NOTE

- You can set only the reading area size in the Controller's system area setting. Refer to the GP-Pro EX Reference Manual for the reading area size.
- Cf. GP-Pro EX Reference Manual "LS Area (only for direct access method Area)"
- Refer to the precautions on manual notation for icons in the table.
 -  "Manual Symbols and Terminology"
- Even if you use a nonexistent address, the read error may not be displayed. In this case, "0" is retained for the read data. Note that the write error is displayed.

6.11 DCP31/DCP32

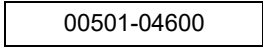
 : This address can be specified as system data area.

Device	Bit Address	Word Address	32 bits	Remarks
Data	00501.0-04600.F	 00501-04600		*1

*1 When bits are written, the Display reads the corresponding word address from the External Device, sets particular bits of that word address to ON, and then returns the resulting address to the External Device. Note that the correct data may not be written if you change the word address using the ladder program while the Display reads data from the External Device and returns it.

IMPORTANT

- Setting [Enable System Data Area] in the system area setting of GP-Pro EX may cause malfunction. Do not set [Enable System Data Area].

NOTE

- You can set only the reading area size in the Controller's system area setting. Refer to the GP-Pro EX Reference Manual for the reading area size.

Cf. GP-Pro EX Reference Manual "LS Area (only for direct access method Area)"

- Refer to the precautions on manual notation for icons in the table.

 "Manual Symbols and Terminology"

- Even if you use a nonexistent address, the read error may not be displayed. In this case, "0" is retained for the read data. Note that the write error is displayed.

6.12 DCP551

 : This address can be specified as system data area.

Device	Bit Address	Word Address	32 bits	Remarks
Data	00256.0-01712.F	00256-01712		*1

*1 When bits are written, the Display reads the corresponding word address from the External Device, sets particular bits of that word address to ON, and then returns the resulting address to the External Device. Note that the correct data may not be written if you change the word address using the ladder program while the Display reads data from the External Device and returns it.

IMPORTANT

- Setting [Enable System Data Area] in the system area setting of GP-Pro EX may cause malfunction. Do not set [Enable System Data Area].

NOTE

- You can set only the reading area size in the Controller's system area setting. Refer to the GP-Pro EX Reference Manual for the reading area size.

Cf. GP-Pro EX Reference Manual "LS Area (only for direct access method Area)"



- Refer to the precautions on manual notation for icons in the table.

 "Manual Symbols and Terminology"

- Even if you use a nonexistent address, the read error may not be displayed. In this case, "0" is retained for the read data. Note that the write error is displayed.

6.13 DCP552

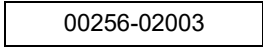
 : This address can be specified as system data area.

Device	Bit Address	Word Address	32 bits	Remarks
Data	00256.0-02003.F	 00256-02003		*1

*1 When bits are written, the Display reads the corresponding word address from the External Device, sets particular bits of that word address to ON, and then returns the resulting address to the External Device. Note that the correct data may not be written if you change the word address using the ladder program while the Display reads data from the External Device and returns it.

IMPORTANT

- Setting [Enable System Data Area] in the system area setting of GP-Pro EX may cause malfunction. Do not set [Enable System Data Area].

NOTE

- You can set only the reading area size in the Controller's system area setting. Refer to the GP-Pro EX Reference Manual for the reading area size.

Cf. GP-Pro EX Reference Manual "LS Area (only for direct access method Area)"



- Refer to the precautions on manual notation for icons in the table.

 "Manual Symbols and Terminology"

- Even if you use a nonexistent address, the read error may not be displayed. In this case, "0" is retained for the read data. Note that the write error is displayed.

6.14 CMC10B

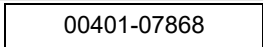
 : This address can be specified as system data area.

Device	Bit Address	Word Address	32 bits	Remarks
Data	00401.0-07868.F	 00401-07868		*1

*1 When bits are written, the Display reads the corresponding word address from the External Device, sets particular bits of that word address to ON, and then returns the resulting address to the External Device. Note that the correct data may not be written if you change the word address using the ladder program while the Display reads data from the External Device and returns it.

IMPORTANT

- Setting [Enable System Data Area] in the system area setting of GP-Pro EX may cause malfunction. Do not set [Enable System Data Area].

NOTE

- You can set only the reading area size in the Controller's system area setting. Refer to the GP-Pro EX Reference Manual for the reading area size.

Cf. GP-Pro EX Reference Manual "LS Area (only for direct access method Area)"



- Refer to the precautions on manual notation for icons in the table.

 "Manual Symbols and Terminology"

- Even if you use a nonexistent address, the read error may not be displayed. In this case, "0" is retained for the read data. Note that the write error is displayed.

6.15 PBC

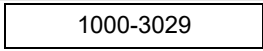
 : This address can be specified as system data area.

Device	Bit Address	Word Address	32 bits	Remarks
Data	1000.0-3029.F	 1000-3029		*1

*1 When bits are written, the Display reads the corresponding word address from the External Device, sets particular bits of that word address to ON, and then returns the resulting address to the External Device. Note that the correct data may not be written if you change the word address using the ladder program while the Display reads data from the External Device and returns it.

IMPORTANT

- Setting [Enable System Data Area] in the system area setting of GP-Pro EX may cause malfunction. Do not set [Enable System Data Area].

NOTE

- You can set only the reading area size in the Controller's system area setting. Refer to the GP-Pro EX Reference Manual for the reading area size.



Cf. GP-Pro EX Reference Manual "LS Area (only for direct access method Area)"

- Refer to the precautions on manual notation for icons in the table.

 "Manual Symbols and Terminology"

6.16 CMS/CMF015

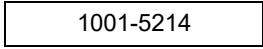
 : This address can be specified as system data area.

Device	Bit Address	Word Address	32 bits	Remarks
Data	1001.0-5214.F	 1001-5214		*1

*1 When bits are written, the Display reads the corresponding word address from the External Device, sets particular bits of that word address to ON, and then returns the resulting address to the External Device. Note that the correct data may not be written if you change the word address using the ladder program while the Display reads data from the External Device and returns it.

IMPORTANT

- Setting [Enable System Data Area] in the system area setting of GP-Pro EX may cause malfunction. Do not set [Enable System Data Area].

NOTE

- You can set only the reading area size in the Controller's system area setting. Refer to the GP-Pro EX Reference Manual for the reading area size.



Cf. GP-Pro EX Reference Manual "LS Area (only for direct access method Area)"

- Refer to the precautions on manual notation for icons in the table.

 "Manual Symbols and Terminology"

6.17 CMQ-V

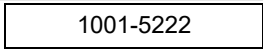
 : This address can be specified as system data area.

Device	Bit Address	Word Address	32 bits	Remarks
Data	1001.0-5222.F	 1001-5222		*1

*1 When bits are written, the Display reads the corresponding word address from the External Device, sets particular bits of that word address to ON, and then returns the resulting address to the External Device. Note that the correct data may not be written if you change the word address using the ladder program while the Display reads data from the External Device and returns it.

IMPORTANT

- Setting [Enable System Data Area] in the system area setting of GP-Pro EX may cause malfunction. Do not set [Enable System Data Area].

NOTE

- You can set only the reading area size in the Controller's system area setting. Refer to the GP-Pro EX Reference Manual for the reading area size.



Cf. GP-Pro EX Reference Manual "LS Area (only for direct access method Area)"

- Refer to the precautions on manual notation for icons in the table.

 "Manual Symbols and Terminology"

6.18 MPC

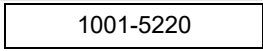
 : This address can be specified as system data area.

Device	Bit Address	Word Address	32 bits	Remarks
Data	1001.0-5220.F	 1001-5220		*1

*1 When bits are written, the Display reads the corresponding word address from the External Device, sets particular bits of that word address to ON, and then returns the resulting address to the External Device. Note that the correct data may not be written if you change the word address using the ladder program while the Display reads data from the External Device and returns it.

IMPORTANT

- Setting [Enable System Data Area] in the system area setting of GP-Pro EX may cause malfunction. Do not set [Enable System Data Area].

NOTE

- You can set only the reading area size in the Controller's system area setting. Refer to the GP-Pro EX Reference Manual for the reading area size.



Cf. GP-Pro EX Reference Manual "LS Area (only for direct access method Area)"

- Refer to the precautions on manual notation for icons in the table.

 "Manual Symbols and Terminology"

6.19 MVF

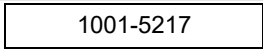
 : This address can be specified as system data area.

Device	Bit Address	Word Address	32 bits	Remarks
Data	1001.0-5217.F	 1001-5217		*1

*1 When bits are written, the Display reads the corresponding word address from the External Device, sets particular bits of that word address to ON, and then returns the resulting address to the External Device. Note that the correct data may not be written if you change the word address using the ladder program while the Display reads data from the External Device and returns it.

IMPORTANT

- Setting [Enable System Data Area] in the system area setting of GP-Pro EX may cause malfunction. Do not set [Enable System Data Area].

NOTE

- You can set only the reading area size in the Controller's system area setting. Refer to the GP-Pro EX Reference Manual for the reading area size.



Cf. GP-Pro EX Reference Manual "LS Area (only for direct access method Area)"

- Refer to the precautions on manual notation for icons in the table.

 "Manual Symbols and Terminology"

6.20 CML/CMF050

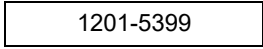
 : This address can be specified as system data area.

Device	Bit Address	Word Address	32 bits	Remarks
Data	1201.0-5399.F	 1201-5399		*1

*1 When bits are written, the Display reads the corresponding word address from the External Device, sets particular bits of that word address to ON, and then returns the resulting address to the External Device. Note that the correct data may not be written if you change the word address using the ladder program while the Display reads data from the External Device and returns it.

IMPORTANT

- Setting [Enable System Data Area] in the system area setting of GP-Pro EX may cause malfunction. Do not set [Enable System Data Area].

NOTE

- You can set only the reading area size in the Controller's system area setting. Refer to the GP-Pro EX Reference Manual for the reading area size.

Cf. GP-Pro EX Reference Manual "LS Area (only for direct access method Area)"



- Refer to the precautions on manual notation for icons in the table.

 "Manual Symbols and Terminology"

- When an address that does not exist in the controller is read out, the value of 65535 is read out but no error is displayed. Also, when an address that does not exist in the controller is used in the project, the value of 65535 may be read out even when it is the address data existing in the controller.

6.21 AUR350C

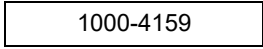
 : This address can be specified as system data area.

Device	Bit Address	Word Address	32 bits	Remarks
Data	1000.0-4159.F	 1000-4159		*1

*1 When bits are written, the Display reads the corresponding word address from the External Device, sets particular bits of that word address to ON, and then returns the resulting address to the External Device. Note that the correct data may not be written if you change the word address using the ladder program while the Display reads data from the External Device and returns it.

IMPORTANT

- Setting [Enable System Data Area] in the system area setting of GP-Pro EX may cause malfunction. Do not set [Enable System Data Area].
- Change the setting for [Text Data Mode] to "2" in the communication settings of GP-Pro EX. The correct value is not displayed when the initial value "1" is specified.



NOTE

- You can set only the reading area size in the Controller's system area setting. Refer to the GP-Pro EX Reference Manual for the reading area size.
- Cf. GP-Pro EX Reference Manual "LS Area (only for direct access method Area)"
- Refer to the precautions on manual notation for icons in the table.

 "Manual Symbols and Terminology"

6.22 AUR450C

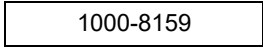
 : This address can be specified as system data area.

Device	Bit Address	Word Address	32 bits	Remarks
Data	1000.0-8159.F	 1000-8159		*1

*1 When bits are written, the Display reads the corresponding word address from the External Device, sets particular bits of that word address to ON, and then returns the resulting address to the External Device. Note that the correct data may not be written if you change the word address using the ladder program while the Display reads data from the External Device and returns it.

IMPORTANT

- Setting [Enable System Data Area] in the system area setting of GP-Pro EX may cause malfunction. Do not set [Enable System Data Area].
- Change the setting for [Text Data Mode] to "2" in the communication settings of GP-Pro EX. The correct value is not displayed when the initial value "1" is specified.



NOTE

- You can set only the reading area size in the Controller's system area setting. Refer to the GP-Pro EX Reference Manual for the reading area size.
- Cf. GP-Pro EX Reference Manual "LS Area (only for direct access method Area)"
- Refer to the precautions on manual notation for icons in the table.

 "Manual Symbols and Terminology"

6.23 RX

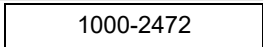
 : This address can be specified as system data area.

Device	Bit Address	Word Address	32 bits	Remarks
Data	1000.0-2472.F	 1000-2472		*1

*1 When bits are written, the Display reads the corresponding word address from the External Device, sets particular bits of that word address to ON, and then returns the resulting address to the External Device. Note that the correct data may not be written if you change the word address using the ladder program while the Display reads data from the External Device and returns it.

IMPORTANT

- Setting [Enable System Data Area] in the system area setting of GP-Pro EX may cause malfunction. Do not set [Enable System Data Area].

NOTE

- You can set only the reading area size in the Controller's system area setting. Refer to the GP-Pro EX Reference Manual for the reading area size.



Cf. GP-Pro EX Reference Manual "LS Area (only for direct access method Area)"

- Refer to the precautions on manual notation for icons in the table.

 "Manual Symbols and Terminology"

6.24 BC-R

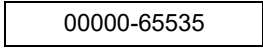
 : This address can be specified as system data area.

Device	Bit Address	Word Address	32 bits	Remarks
Data	00000.0-65535.F	 00000-65535		*1

*1 When bits are written, the Display reads the corresponding word address from the External Device, sets particular bits of that word address to ON, and then returns the resulting address to the External Device. Note that the correct data may not be written if you change the word address using the ladder program while the Display reads data from the External Device and returns it.

IMPORTANT

- Setting [Enable System Data Area] in the system area setting of GP-Pro EX may cause malfunction. Do not set [Enable System Data Area].

NOTE

- Note that the actually supported range varies depending on the External Device to be used. Please check the actual range in your External Device manual.
- You can set only the reading area size in the Controller's system area setting. Refer to the GP-Pro EX Reference Manual for the reading area size.

Cf. GP-Pro EX Reference Manual "LS Area (only for direct access method Area)"

- Refer to the precautions on manual notation for icons in the table.

 "Manual Symbols and Terminology"

6.25 C1M

 : This address can be specified as system data area.

Device	Bit Address	Word Address	32 bits	Remarks
Data	00273.0-14859.F 16657.0-31243.F	00273-14859 16657-31243		*1

*1 When bits are written, the Display reads the corresponding word address from the External Device, sets particular bits of that word address to ON, and then returns the resulting address to the External Device. Note that the correct data may not be written if you change the word address using the ladder program while the Display reads data from the External Device and returns it.

IMPORTANT

- Setting [Enable System Data Area] in the system area setting of GP-Pro EX may cause malfunction. Do not set [Enable System Data Area].

NOTE

- Note that the actually supported range varies depending on the External Device to be used. Please check the actual range in your External Device manual.
- You can set only the reading area size in the Controller's system area setting. Refer to the GP-Pro EX Reference Manual for the reading area size.

Cf. GP-Pro EX Reference Manual "LS Area (only for direct access method Area)"

- Refer to the precautions on manual notation for icons in the table.

 "Manual Symbols and Terminology"

7 Device Code and Address Code

Use device code and address code when you select "Device Type & Address" for the address type of the data display or other devices.

7.1 SDC10

Device	Device Name	Device Code (HEX)	Address Code
Data	---	0080	Word Address

7.2 SDC15 /SDC 25/SDC26 / SDC35/SDC36

Device	Device Name	Device Code (HEX)	Address Code
Data	---	0080	Word Address

7.3 SDC20/SDC21

Device	Device Name	Device Code (HEX)	Address Code
Data	---	0080	Word Address

7.4 SDC30/SDC31

Device	Device Name	Device Code (HEX)	Address Code
Data	---	0080	Word Address

7.5 SDC40A

Device	Device Name	Device Code (HEX)	Address Code
Data	---	0080	Word Address

7.6 SDC40B

Device	Device Name	Device Code (HEX)	Address Code
Data	---	0080	Word Address

7.7 SDC40G

Device	Device Name	Device Code (HEX)	Address Code
Data	---	0080	Word Address

7.8 SDC45/46

Device	Device Name	Device Code (HEX)	Address Code
Data	---	0080	Word Address

7.9 DMC10

Device	Device Name	Device Code (HEX)	Address Code
Data	---	0080	Word Address

7.10 DMC50

Device	Device Name	Device Code (HEX)	Address Code
Data	000	0080	Word Address
Data	001	0081	Word Address
Data	002	0082	Word Address
Data	021	00A1	Word Address
Data	022	00A2	Word Address
Data	023	00A3	Word Address
Data	041	00C1	Word Address
Data	045	00C5	Word Address
Data	061	00E1	Word Address
Data	071	00F1	Word Address
Data	074	00F4	Word Address
Data	0A1	0121	Word Address
Data	0A2	0122	Word Address
Data	0A3	0123	Word Address
Data	0C1	0141	Word Address
Data	0C3	0143	Word Address

Continued to next page.

Device	Device Name	Device Code (HEX)	Address Code
Data	0C4	0144	Word Address
Data	0C5	0145	Word Address
Data	0C6	0146	Word Address
Data	0E1	0161	Word Address
Data	0E2	0162	Word Address
Data	0E3	0163	Word Address
Data	0E5	0165	Word Address
Data	0E6	0166	Word Address
Data	0E7	0167	Word Address
Data	0E8	0168	Word Address
Data	0F1	0171	Word Address
Data	0F2	0172	Word Address
Data	0F3	0173	Word Address
Data	103	0183	Word Address
Data	201	0281	Word Address
Data	202	0282	Word Address
Data	203	0283	Word Address
Data	211	0291	Word Address
Data	212	0292	Word Address
Data	213	0293	Word Address
Data	214	0294	Word Address
Data	234	02B4	Word Address
Data	235	02B5	Word Address
Data	236	02B6	Word Address
Data	241	02C1	Word Address
Data	242	02C2	Word Address
Data	243	02C3	Word Address
Data	301	0381	Word Address
Data	801 802 9FE 9FF	0881 0882 0A7E 0A7F	Word Address

Continued to next page.

Device	Device Name	Device Code (HEX)	Address Code
Data	C00	0C80	Word Address
Data	C01 C02 C62 C63	0C81 0C82 0CE2 0CE3	Word Address
Data	CF1	0D71	Word Address

7.11 DCP31/DCP32

Device	Device Name	Device Code (HEX)	Address Code
Data	---	0080	Word Address

7.12 DCP551

Device	Device Name	Device Code (HEX)	Address Code
Data	---	0080	Word Address

7.13 DCP552

Device	Device Name	Device Code (HEX)	Address Code
Data	---	0080	Word Address

7.14 CMC10B

Device	Device Name	Device Code (HEX)	Address Code
Data	---	0080	Word Address

7.15 PBC

Device	Device Name	Device Code (HEX)	Address Code
Data	---	0080	Word Address

7.16 CMS/CMF015

Device	Device Name	Device Code (HEX)	Address Code
Data	---	0080	Word Address

7.17 CMQ-V

Device	Device Name	Device Code (HEX)	Address Code
Data	---	0080	Word Address

7.18 MPC

Device	Device Name	Device Code (HEX)	Address Code
Data	---	0080	Word Address

7.19 MVF

Device	Device Name	Device Code (HEX)	Address Code
Data	---	0080	Word Address

7.20 CML/CMF050

Device	Device Name	Device Code (HEX)	Address Code
Data	---	0080	Word Address

7.21 AUR350C

Device	Device Name	Device Code (HEX)	Address Code
Data	---	0080	Word Address

7.22 AUR450C

Device	Device Name	Device Code (HEX)	Address Code
Data	---	0080	Word Address

7.23 RX

Device	Device Name	Device Code (HEX)	Address Code
Data	---	0080	Word Address

7.24 BC-R

Device	Device Name	Device Code (HEX)	Address Code
Data	---	0080	Word Address

7.25 C1M

Device	Device Name	Device Code (HEX)	Address Code
Data	---	0080	Word Address

8 Error Messages

Error messages are displayed on the Display screen as follows: "No.: Device Name: Error Message (Error Occurrence Area)". Each description is shown below.

Item	Description
No.	Error No.
Device Name	Name of the External Device where an error has occurred. Device name is the title of the External Device set with GP-Pro EX. (Initial value [PLC1])
Error Message	Displays messages related to an error that has occurred.
Error Occurrence Area	Displays the IP address or device address of the External Device where an error has occurred, or error codes received from the External Device. <div style="border: 1px solid black; padding: 2px; margin: 5px 0;">NOTE</div> <ul style="list-style-type: none"> • IP address is displayed as "IP address (Decimal): MAC address (Hex)". • Device address is displayed as "Address: Device address". • Received error codes are displayed as "Decimal [Hex]".

Display Examples of Error Messages

"RHAA035: PLC1: Error has been responded for device write command (Error Code: 2[02H])"

NOTE

- Refer to your External Device manual for details on received error codes.
 - Refer to "Display-related errors" in "Maintenance/Troubleshooting Guide" for details on the error messages common to the driver.
-

■ Notes on Using the Device Monitor

The External Device has inaccessible areas.

If you attempt to display a range that includes inaccessible areas using the bit or word batch monitor, an error may occur and no data may be displayed.

In this case, set the address you want to display as the first one, or use the random monitor.

