



Robot Positioner TS Series Driver

1	System Configuration.....	3
2	External Device Selection	7
3	Communication Settings	8
4	Setup Items	10
5	Cable Diagram	15
6	Supported Devices.....	20
7	Device Code and Address Code.....	23
8	Error Messages.....	25

Introduction

This manual describes how to connect the Display and the External Device (target PLC).

In this manual, the connection procedure will be described in the sections identified below:

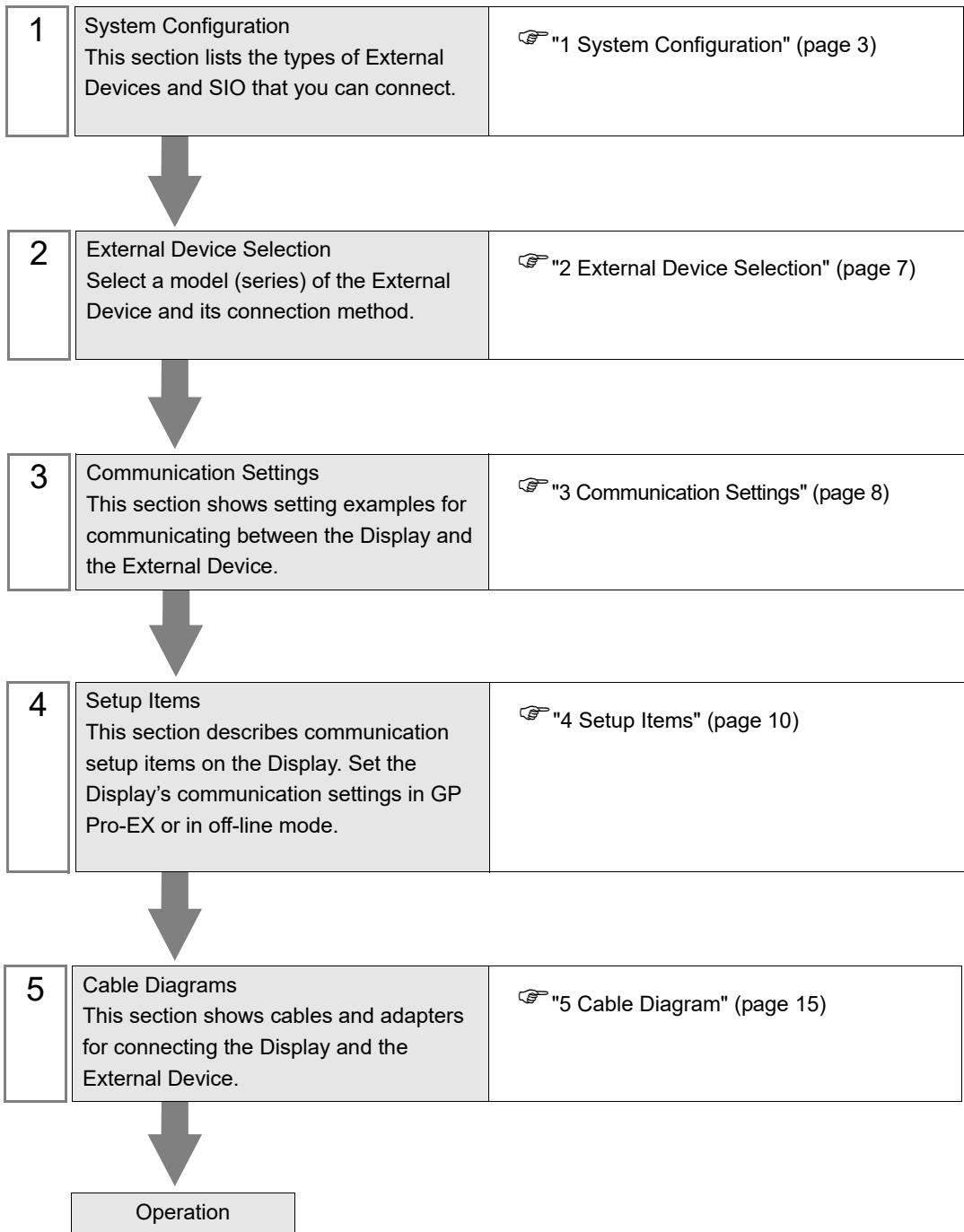

1 System Configuration

The system configuration in the case when the External Device of Yamaha Motor Co., Ltd. and the Display are connected is shown.

Series	CPU	Link I/F	SIO Type	Setting Example	Cable Diagram
TS-S	TS-S	COM1 on Controller	RS232C	Setting Example 1 (page 8)	Cable Diagram 1 (page 15)
TS-X	TS-X105 TS-X110 TS-X205 TS-X210 TS-X220			Setting Example 1 (page 8)	Cable Diagram 1 (page 15)
TS-P	TS-P105 TS-P110 TS-P205 TS-P210 TS-P220			Setting Example 1 (page 8)	Cable Diagram 1 (page 15)

■ Connection Configuration

- 1:1 Connection

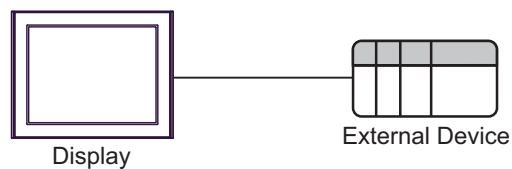

- 1:n Connection

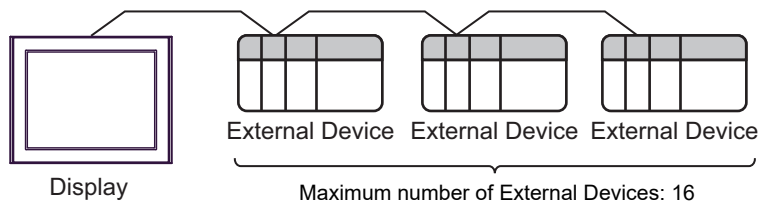

NOTE

- To set up a 1:n connection, software on the External Device should be Ver.1.05.110 or later.

■ IPC COM Port

When connecting IPC with an External Device, the COM port used depends on the series and SIO type. Please refer to the IPC manual for details.

Usable port

Series	Usable Port		
	RS-232C	RS-422/485(4 wire)	RS-422/485(2 wire)
PS-2000B	COM1 ^{*1} , COM2, COM3 ^{*1} , COM4	-	-
PS-3450A, PS-3451A, PS3000-BA, PS3001-BD	COM1, COM2 ^{*1*2}	COM2 ^{*1*2}	COM2 ^{*1*2}
PS-3650A (T41 model), PS-3651A (T41 model)	COM1 ^{*1}	-	-
PS-3650A (T42 model), PS-3651A (T42 model)	COM1 ^{*1*2} , COM2	COM1 ^{*1*2}	COM1 ^{*1*2}
PS-3700A (Pentium®4-M) PS-3710A	COM1 ^{*1} , COM2 ^{*1} , COM3 ^{*2} , COM4	COM3 ^{*2}	COM3 ^{*2}
PS-3711A	COM1 ^{*1} , COM2 ^{*2}	COM2 ^{*2}	COM2 ^{*2}
PS4000 ^{*3}	COM1, COM2	-	-
PL3000	COM1 ^{*1*2} , COM2 ^{*1} , COM3, COM4	COM1 ^{*1*2}	COM1 ^{*1*2}
PE-4000B Atom N270	COM1, COM2	-	-
PE-4000B Atom N2600	COM1, COM2	COM3 ^{*4} , COM4 ^{*4} , COM5 ^{*4} , COM6 ^{*4}	COM3 ^{*4} , COM4 ^{*4} , COM5 ^{*4} , COM6 ^{*4}
PS5000 (Slim Panel Type Core i3 Model) ^{*5*6}	COM1, COM2 ^{*4}	COM2 ^{*4}	COM2 ^{*4}
PS5000 (Slim Panel Type Atom Model) ^{*5*6}	COM1, COM2 ^{*7}	COM2 ^{*7}	COM2 ^{*7}
PS5000 (Enclosed Panel Type) ^{*8}	COM1	-	-
PS5000 (Modular Type PFXPU/PFXPP) ^{*5*6} PS5000 (Modular Type PFXPL2B5-6)	COM1 ^{*7}	COM1 ^{*7}	COM1 ^{*7}
PS5000 (Modular Type PFXPL2B1-4)	COM1, COM2 ^{*7}	COM2 ^{*7}	COM2 ^{*7}
PS6000 (Advanced Box) PS6000 (Standard Box)	COM1 ^{*9}	*10	*10
PS6000 (Basic Box)	COM1 ^{*9}	COM1 ^{*9}	COM1 ^{*9}

*1 The RI/5V can be switched. Use the IPC's switch to change if necessary.

*2 Set up the SIO type with the DIP Switch. Please set up as follows according to SIO type to be used.

- *3 When making communication between an External Device and COM port on the Expansion slot, only RS-232C is supported. However, ER (DTR/CTS) control cannot be executed because of the specification of COM port.
For connection with External Device, use user-created cables and disable Pin Nos. 1, 4, 6 and 9. Please refer to the IPC manual for details of pin layout.
- *4 Set up the SIO type with the BIOS. Please refer to the IPC manual for details of BIOS.
- *5 When setting up communication between an External Device and the RS-232C/422/485 interface module, use the IPC (RS-232C) or PS5000 (RS-422/485) cable diagrams. However, when using PFXZPBMPR42P2 in a RS-422/485 (4-wire) configuration with no flow control, connect 7.RTS+ and 8.CTS+, and connect 6.RTS- and 9.CTS-.
When using RS-422/485 communication with External Devices, you may need to reduce the transmission speed and increase the TX Wait time.
- *6 To use RS-422/485 communication on the RS-232C/422/485 interface module, the DIP Switch setting is required. Please refer to "Knowledge Base" (FAQs) on the support site. (<http://www.pro-face.com/trans/en/manual/1001.html>)

Settings	FAQ ID
PFXZPBMPR42P2, RS422/485 change method	FA263858
PFXZPBMPR42P2 termination resistor setting	FA263974
PFXZPBMPR44P2, RS422/485 change method	FA264087
PFXZPBMPR44P2 termination resistor setting	FA264088

- *7 Set up the SIO type with the DIP Switch. Please refer to the IPC manual for details of DIP Switch. The BOX Atom has not a switch to set the RS-232C, RS-422/485 mode. Use the BIOS for the setting.
- *8 For the connection with the External Device, on the user-created cable read as if the connector on the Display-side is a M12 A-coding 8 pin socket. The pin assignment is the same as described in the cable diagram. For the M12 A-coding connector, use PFXZPSCNM122.
- *9 In addition to COM1, you can also use the COM port on the optional interface.
- *10 Install the optional interface in the expansion slot.

DIP Switch settings (PL3000 / PS3000 Series)

RS-232C

DIP Switch	Setting	Description
1	OFF*1	Reserved (always OFF)
2	OFF	SIO type: RS-232C
3	OFF	
4	OFF	Output mode of SD (TXD) data: Always output
5	OFF	Terminal resistance (220Ω) insertion to SD (TXD): None
6	OFF	Terminal resistance (220Ω) insertion to RD (RXD): None
7	OFF	Short-circuit of SDA (TXA) and RDA (RXA): Not available
8	OFF	Short-circuit of SDB (TXB) and RDB (RXB): Not available
9	OFF	RS (RTS) Auto control mode: Disabled
10	OFF	

*1 When using PS-3450A, PS-3451A, PS3000-BA and PS3001-BD, turn ON the set value.

RS-422/485 (4 wire)

DIP Switch	Setting	Description
1	OFF	Reserved (always OFF)
2	ON	SIO type: RS-422/485
3	ON	
4	OFF	Output mode of SD (TXD) data: Always output
5	OFF	Terminal resistance (220Ω) insertion to SD (TXD): None
6	OFF	Terminal resistance (220Ω) insertion to RD (RXD): None
7	OFF	Short-circuit of SDA (TXA) and RDA (RXA): Not available
8	OFF	Short-circuit of SDB (TXB) and RDB (RXB): Not available
9	OFF	RS (RTS) Auto control mode: Disabled
10	OFF	

RS-422/485 (2 wire)

DIP Switch	Setting	Description
1	OFF	Reserved (always OFF)
2	ON	SIO type: RS-422/485
3	ON	
4	OFF	Output mode of SD (TXD) data: Always output
5	OFF	Terminal resistance (220Ω) insertion to SD (TXD): None
6	OFF	Terminal resistance (220Ω) insertion to RD (RXD): None
7	ON	Short-circuit of SDA (TXA) and RDA (RXA): Available
8	ON	Short-circuit of SDB (TXB) and RDB (RXB): Available
9	ON	RS (RTS) Auto control mode: Enabled
10	ON	

2 External Device Selection

Select the External Device to be connected to the Display.

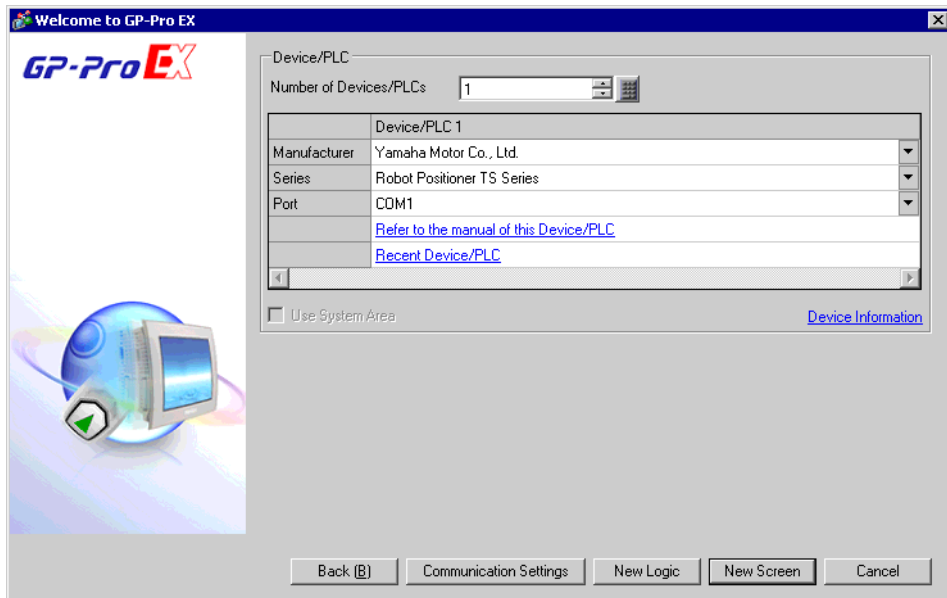

Setup Items	Setup Description
Number of Devices/PLCs	Use an integer from 1 to 4 to enter the number of Devices/PLCs to connect to the display.
Manufacturer	Select the manufacturer of the External Device to be connected. Select "Yamaha Motor Co., Ltd.".
Series	Select a model (series) of the External Device to be connected and connection method. Select "Robot Positioner TS Series". Check the External Device which can be connected in "Robot Positioner TS Series" in system configuration. ☞ "1 System Configuration" (page 3)
Port	Select the Display port to be connected to the External Device.
Use System Area	Not available in this driver.

3 Communication Settings

Examples of communication settings of the Display and the External Device, recommended by Pro-face, are shown.

3.1 Setting Example 1

■ Settings of GP-Pro EX

◆ Communication Settings

To display the setup screen, from the [Project] menu, point to [System Settings] and select [Device/PLC].

The screenshot shows the 'Device/PLC 1' configuration window. It includes a 'Summary' section with fields for Manufacturer (Yamaha Motor Co., Ltd.), Series (Robot Positioner TS Series), and Port (COM1). Below this is the 'Communication Settings' section with radio buttons for RS232C (selected), RS422/485(2wire), and RS422/485(4wire). Other settings include Speed (38400), Data Length (8), Parity (ODD), Stop Bit (1), Flow Control (NONE), Timeout (3 sec), Retry (2), and Wait To Send (0 ms). There are also options for RI/VCC (RI selected) and a 'Default' button. The 'Device-Specific Settings' section shows 'Allowable Number of Devices/PLCs' as 16 and a table with one entry: No. 1, Device Name PLC1, Settings Node(Controller)=1. An 'Add Device' button is also present.

◆ Device Setting

To display the [Individual Device Settings] dialog box, from [Device-Specific Settings] in the [Device/PLC] window, select the External Device and click [Settings]. To connect multiple External Devices, from [Device-Specific Settings] in the [Device/PLC] window, click [Add Device] to add another External Device.

The screenshot shows the 'Individual Device Settings' dialog box for PLC1. It has a single text input field for 'Node(Controller)' with the value '1'. There are 'Default', 'OK', and 'Cancel' buttons.

■ Settings of External Device

1:1 connections do not require communication setup.

In 1:n connections, use TS Manager version V1.2.0 or later to set the Automatic Node Number Assignment.

For details on communication settings, please refer to the manual of the External Device.

NOTE

- To use both the host control device and the Display together, on the host control device turn ON the interlock (/LOCK) signal. The External Device will not operate unless the interlock signal is ON.
 - To use the Display only, set the External Device Option parameters number 80, "Option enable", to "Disable." You can operate the External Device without the interlock.
-

4 Setup Items

Set up the Display's communication settings in GP Pro-EX or in the Display's offline mode.

The setting of each parameter must match that of the External Device.

☞ "3 Communication Settings" (page 8)

4.1 Setup Items in GP-Pro EX

■ Communication Settings

To display the setup screen, from the [Project] menu, point to [System Settings] and select [Device/PLC].

Device/PLC 1

Summary [Change Device/PLC](#)

Manufacturer Series Port

Text Data Mode [Change](#)

Communication Settings

SIO Type RS232C RS422/485(2wire) RS422/485(4wire)

Speed

Data Length 7 8

Parity NONE EVEN ODD

Stop Bit 1 2

Flow Control NONE ER(DTR/CTS) XON/XOFF

Timeout (sec)

Retry

Wait To Send (ms)

RI / VCC RI VCC

In the case of RS232C, you can select the 9th pin to RI (Input) or VCC (5V Power Supply). If you use the Digital's RS232C Isolation Unit, please select it to VCC.

Device-Specific Settings

Allowable Number of Devices/PLCs [Add Device](#)

No.	Device Name	Settings	Add Indirect Device
<input type="button" value="1"/>	<input type="text" value="PLC1"/>	<input type="text" value="Node(Controller)=1"/>	<input type="button" value="+"/>

Setup Items	Setup Description
SIO Type	Select the SIO type to communicate with the External Device.
Speed	Select speed between the External Device and the Display.
Data Length	Select data length.
Parity	Select how to check parity.
Stop Bit	Select stop bit length.
Flow Control	Display the communication control method to prevent overflow of transmission and reception data.
Timeout	Use an integer from 1 to 127 to enter the time (s) for which the Display waits for the response from the External Device.
Retry	In case of no response from the External Device, use an integer from 0 to 255 to enter how many times the Display retransmits the command.
Wait To Send	Use an integer from 0 to 255 to enter standby time (ms) for the Display from receiving packets to transmitting next commands.

Setup Items	Setup Description
RI/VCC	You can switch RI/VCC of the 9th pin when you select RS232C for SIO type. It is necessary to change RI/5V by changeover switch of IPC when connect with IPC. Please refer to the manual of the IPC for more detail.

NOTE

- Refer to the GP-Pro EX Reference Manual for Indirect Device.
Cf. GP-Pro EX Reference Manual "Changing the Device/PLC at Runtime (Indirect Device)"

■ Device Setting

To display the [Individual Device Settings] dialog box, from [Device-Specific Settings] in the [Device/PLC] window, select the External Device and click [Settings] . To connect multiple External Devices, from [Device-Specific Settings] in the [Device/PLC] window, click [Add Device] to add another External Device.

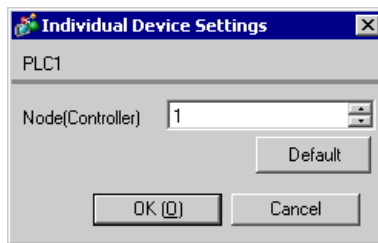

Setup Items	Setup Description
Node (Controller)	Use an integer from 1 to 16 to enter the Node No. of the External Device. (Initial value [0])

4.2 Setup Items in Offline Mode

NOTE

- Please refer to Maintenance/Troubleshooting Guide for more information on how to enter offline mode or about operation.
Cf. Maintenance/Troubleshooting Guide "Offline Mode"
- The number of the setup items to be displayed for 1 page in the offline mode depends on the Display in use. Please refer to the Reference manual for details.

■ Communication Settings

To display the setting screen, touch [Device/PLC Settings] from [Peripheral Settings] in offline mode. Touch the External Device you want to set from the displayed list.

Comm.	Device	Option		
Robot Positioner TS Series		[COM1]	Page 1/1	
SIO Type	RS232C			
Speed	38400			
Data Length	<input type="radio"/> 7 <input checked="" type="radio"/> 8			
Parity	<input type="radio"/> NONE <input type="radio"/> EVEN <input checked="" type="radio"/> ODD			
Stop Bit	<input checked="" type="radio"/> 1 <input type="radio"/> 2			
Flow Control	NONE			
Timeout(s)	3			
Retry	2			
Wait to Send(ms)	0			
Exit		Back		2011/12/25 22:01:23

Setup Items	Setup Description
SIO Type	Select the SIO type to communicate with the External Device. IMPORTANT To make the communication settings correctly, confirm the serial interface specifications of Display unit for [SIO Type]. We cannot guarantee the operation if a communication type that the serial interface does not support is specified. For details concerning the serial interface specifications, refer to the manual for Display unit.
Speed	Select speed between the External Device and the Display.
Data Length	Select data length.
Parity	Select how to check parity.
Stop Bit	Select stop bit length.
Flow Control	Display the communication control method to prevent overflow of transmission and reception data.

Setup Items	Setup Description
Timeout (s)	Use an integer from 1 to 127 to enter the time (s) for which the Display waits for the response from the External Device.
Retry	In case of no response from the External Device, use an integer from 0 to 255 to enter how many times the Display retransmits the command.
Wait To Send (ms)	Use an integer from 0 to 255 to enter standby time (ms) for the Display from receiving packets to transmitting next commands.

■ Device Setting

To display the setting screen, touch [Device/PLC Settings] from [Peripheral Settings]. Touch the External Device you want to set from the displayed list, and touch [Device].

Comm.	Device	Option		
Robot Positioner TS Series		[COM1]	Page 1/1	
Device/PLC Name		[PLC1]		
Node(Controller)		1		
Exit		Back		2011/12/25 22:01:28

Setup Items	Setup Description
Device/PLC Name	Select the External Device for device setting. Device name is a title of External Device set with GP-Pro EX.(Initial value [PLC1])
Node (Controller)	Use an integer from 1 to 16 to enter the Node No. of the External Device. (Initial value [0])

■ Option

To display the setting screen, touch [Device/PLC Settings] from [Peripheral Settings]. Touch the External Device you want to set from the displayed list, and touch [Option].

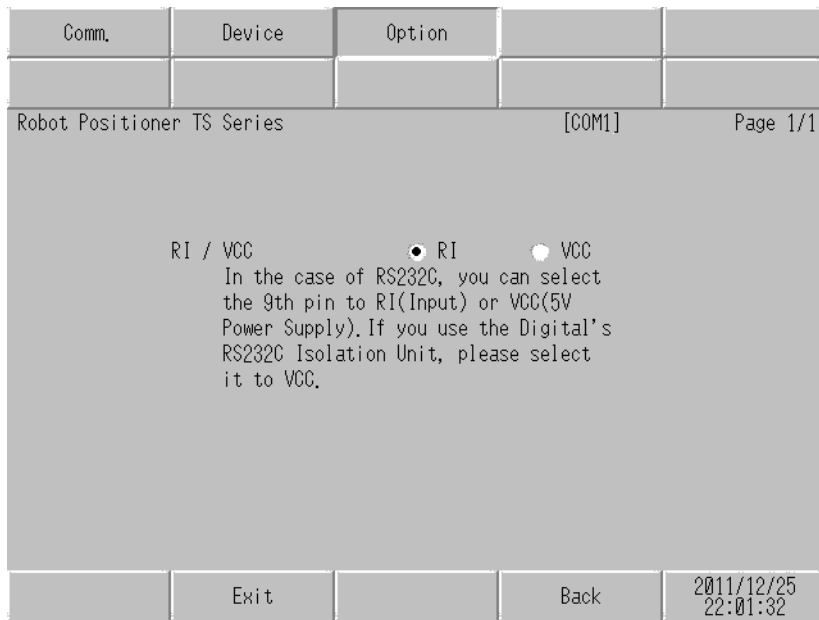

Setup Items	Setup Description
RI/VCC	You can switch RI/VCC of the 9th pin when you select RS232C for SIO type. It is necessary to change RI/5V by changeover switch of IPC when connect with IPC. Please refer to the manual of the IPC for more detail.

NOTE

- GP-4100 series, GP-4*01TM, GP-Rear Module, LT-4*01TM and LT-Rear Module do not have the [Option] setting in the offline mode.

5 Cable Diagram

The cable diagram shown below may be different from the cable diagram recommended by Yamaha Motor Co., Ltd. Please be assured there is no operational problem in applying the cable diagram shown in this manual.

- The FG pin of the External Device body must be D-class grounded. Please refer to the manual of the External Device for more details.
- SG and FG are connected inside the Display. When connecting SG to the External Device, design the system not to form short-circuit loop.
- Connect the isolation unit, when communication is not stabilized under the influence of a noise etc.

Cable Diagram 1

Display (Connection Port)		Cable	Notes
GP3000 (COM1) GP4000*1 (COM1) SP5000*2 (COM1/2) SP-5B00 (COM1) ST3000 (COM1) ST6000 (COM1) STM6000 (COM1) STC6000 (COM1) ET6000 (COM1) LT3000 (COM1) IPC*3 PC/AT	1A	Connection cable by Yamaha Motor Co., Ltd. KCA-M538F-010 (5m) + Connection cable by Yamaha Motor Co., Ltd.*4 KCA-M532L-00 (0.3m)	The cable length must be 6 m or less.
	1B	User-created cable + Connection cable by Yamaha Motor Co., Ltd. KCA-M538F-00 (5m) + Connection cable by Yamaha Motor Co., Ltd.*3 KCA-M532L-00 (0.3m)	
GP-4105 (COM1) GP-4115T (COM1) GP-4115T3 (COM1)	1C	User-created cable + Connection cable by Yamaha Motor Co., Ltd. KCA-M538F-00 (5m) or Connection Cable by Yamaha motor Co.,Ltd. KCA-M538F-010 (5m) + Connection cable by Yamaha Motor Co., Ltd.*3 KCA-M532L-00 (0.3m)	The cable length must be 6 m or less.
LT-4*01TM (COM1) LT-Rear Module (COM1)	1D	RJ45 RS-232C Cable (5m) by Pro-face PFXZLMCBJR21 + Connection cable by Yamaha Motor Co., Ltd. KCA-M538F-00 (5m) or Connection Cable by Yamaha motor Co.,Ltd. KCA-M538F-010 (5m) + Connection cable by Yamaha Motor Co., Ltd.*3 KCA-M532L-00 (0.3m)	The cable length must be 6 m or less.

*1 All GP4000 models except GP-4100 Series and GP-4203T

*2 Except SP-5B00

*3 Only the COM port which can communicate by RS-232C can be used.

 ■ IPC COM Port (page 4)

*4 For 1:n connections, use Yamaha Motor Co., Ltd.'s connection cable (KCA-M532L-00) to connect External Devices.

1A)

1:1 Connection

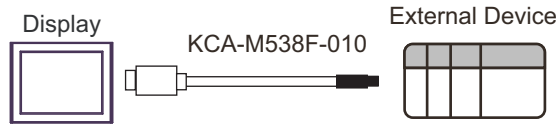

1:n Connection

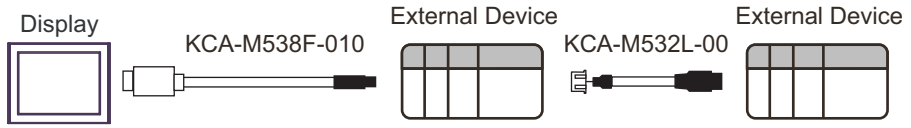

1B)

1:1 Connection

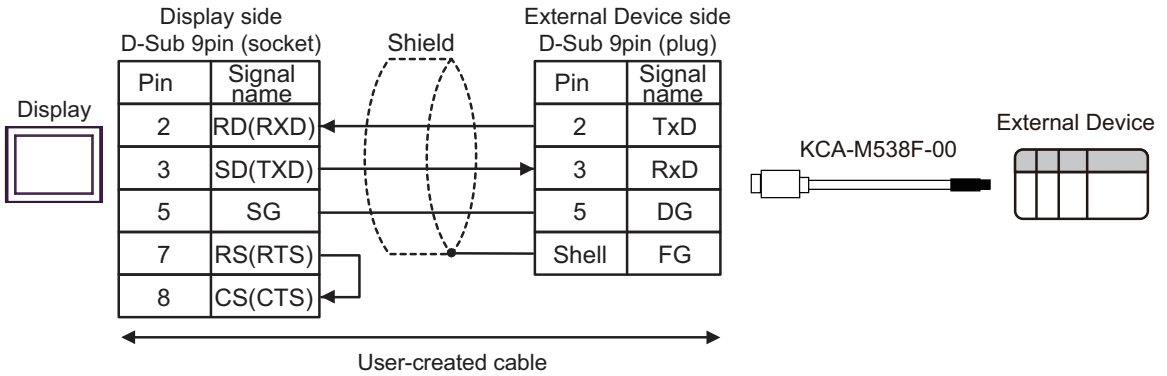

1:n Connection

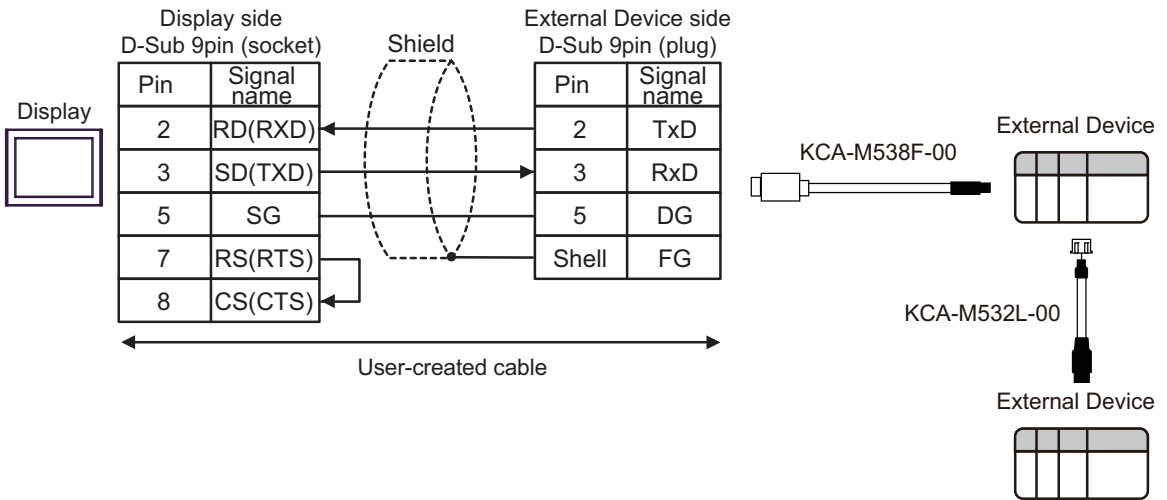

1C)

1:1 Connection

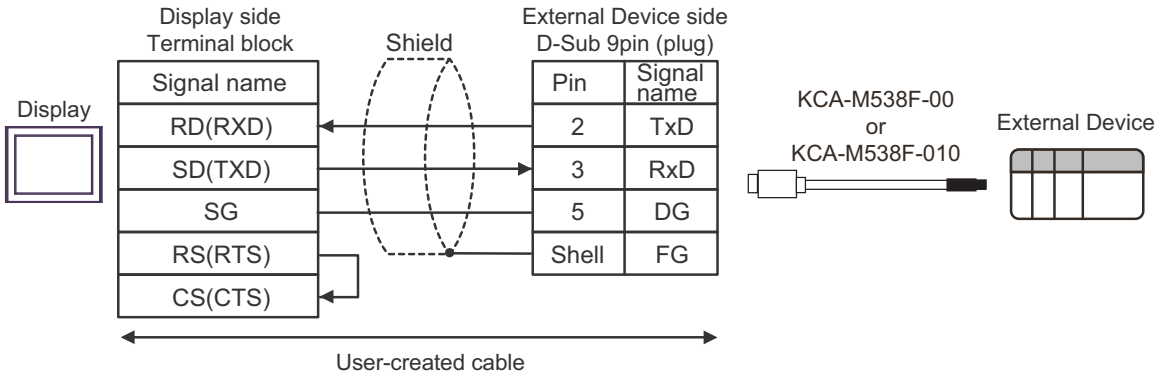

1:n Connection

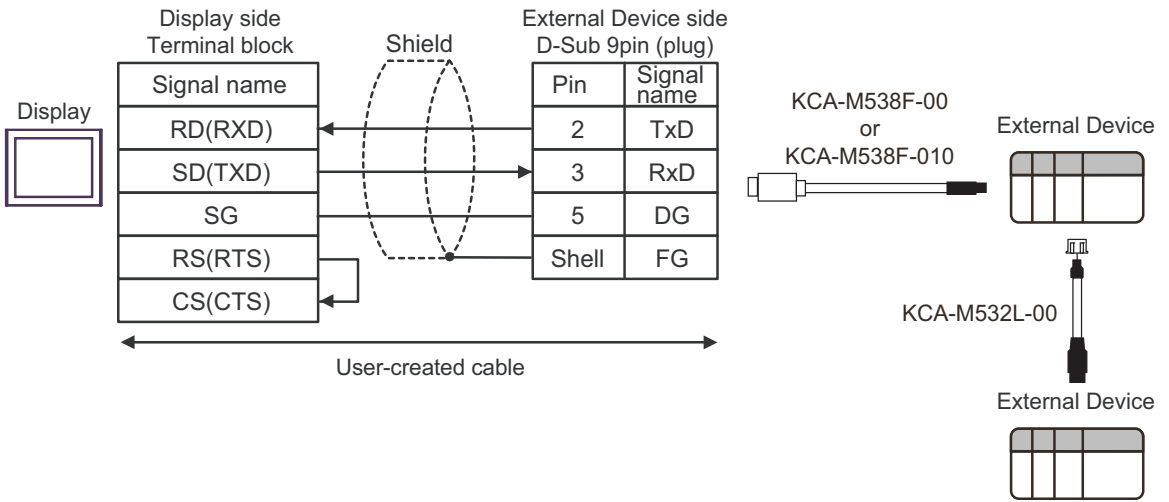

1D)

1:1 Connection

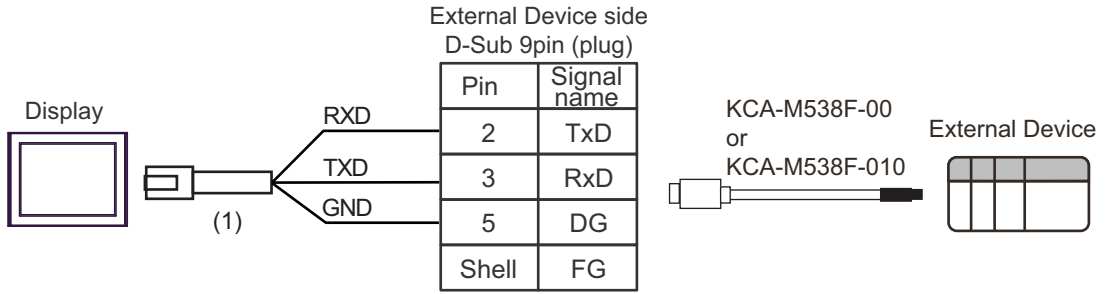

1:n Connection

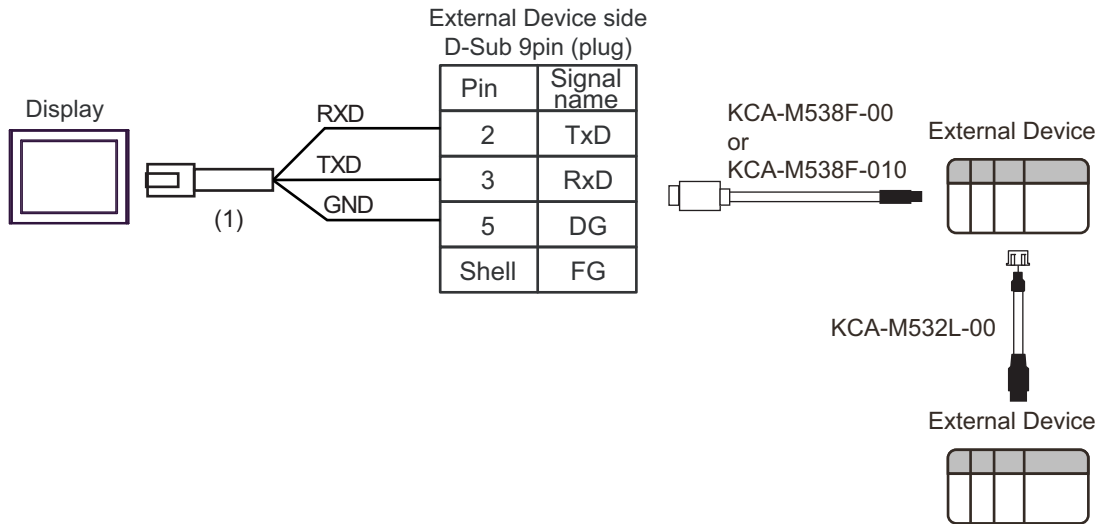

Legend	Name	Notes
(1)	RJ45 RS-232C Cable (5m) by Pro-face PFXZLMCBJR21	

6 Supported Devices

Range of supported device address is shown in the table below.

 This address can be specified as system data area.

Device		Bit Address	Word Address	32bits	Notes
Positioning Operation		-	START		*1 *2 *3
Operation Stop		STOP	-		*3 *4 *5 *6 *7
Return-to-origin		ORG	-		*3 *4
JOG movement (+)		JOGP	-		*3 *4 *8
JOG movement (-)		JOGM	-		*3 *4 *8
Inching movement (+)		INCHP	-		*3 *4
Inching movement (-)		INCHM	-		*3 *4
Servo status change		SERVO	-		*3
Brake status change		BRK	-		*3
Reset		RESET	-		*3 *4
Point Data	Retentive	-	POINT001.□□ - POINT255.□□		*2 *9 *10 *11 *12
	Non-retentive	-	POINT_001.□□ - POINT_255.□□		*2 *9 *10 *11 *12
Current Position Teaching		-	TEACH		*2 *3 *13
Point Data Deleting		-	DELETE		*2 *3 *14
Parameter		-	K001 - K138	L/H	*2 *12 *15
Status information		-	D00 - D20		*12 *16 *17
Input information		INB00 - INB31	IN0		*12 *16
Output information		OUTB00 - OUTB31	OUT0		*12 *16
Option information		OPTB00 - OPTB31	OPT0		*12 *16
Input word information		-	WIN0 - WIN3		*16
Output word information		-	WOUT0 - WOUT3		*16
Alarm information		-	ALM01 - ALM32		*16
Warning information		-	WARN01 - WARN32		*16
Alarm History		-	REC01.□□ - REC50.□□		*16 *18
Message Information		-	MSG		*16
Interface information		-	IF		*16 *19
Controller Name Information		-	CONT		*16 *19
Robot Name Information		-	ROBOT		*16 *19
Version Information		-	VER		*16 *19
RUN Alarm Information		-	RUNALM		*20

*1 Define the point number you want to run, and perform a word write operation.

*2 Writing a value outside the setting range may cause the External Device to become unresponsive. Only write values within the setting range.

- *3 Read disabled.
- *4 Operates when the bit turns on.
- *5 An error displays when turning ON the bit under either of the following conditions:
 - During operation triggered by a command that did not come from the Display
 - While not in operation.
- *6 Depending on the point data setting, the External Device may become unresponsive when stopping operation. Set up the time until the operation ends so it fits into the time-out time.
- *7 When the External Device is running due to input and output signals from the controller, and you use the Display to exit operation, the External Device will stop, but an unresponsive error will appear on the Display.
- *8 When the External Device experiences a SOFTLIMIT OVER error, even if you perform a word write to a JOG movement device (JOGP, JOGM), communication will not be normal. Information on the SOFTLIMIT OVER error is stored in the RUN Alarm Information device (RUNALM).
- *9 The structure of the address portion of the Point Data device (POINT, POINT_) is as follows.

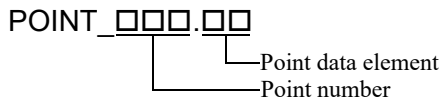
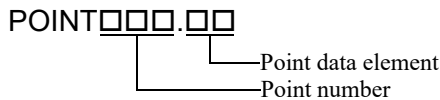

Point data is data that stores movement information for the axis connected to the Robot Controller. There are 255 point data, and each point data has 12 elements. The address identifying the element is called the "point data element," and the address identifying one of the 255 point data is called the "point number."

Point data element	Description
M	RUN type ^{*1}
P	Position
S	Speed
AC	Acceleration
DC	Deceleration
Q	Push
ZL	Zone (-) ^{*1}
ZH	Zone (+) ^{*1}
N	Near width ^{*1}
J	Jump ^{*1}
F	Flag ^{*1}
T	Timer ^{*1}

*1 Non-retentive device (POINT_) is read-only.

e.g. To specify point number 20's Deceleration (DC), use "POINT020.DC."

- *10 Values written to point data's non-retentive device (POINT_) is not written to EEPROM, but to volatile memory. As a result, the value is not retained. If you want to retain the value, in the same point number of the retentive device (POINT), write the operation to the RUN type (M).
To use point data's non-retentive devices (POINT_), use External Device software Ver.1.04.106 or later.
- *11 In point data, when you set the RUN type (M) to 0, data in each element becomes invalid. When you reset the RUN type (M), data in each element becomes valid.

- *12 32-bit device.
- *13 Define the point number you want to teach, and perform a word write operation.
- *14 Define the point number you want to delete, and perform a word write operation.
- *15 Communication system parameters K034, K035, K036, K037, K038, and K039 are read-only addresses.
- *16 Write disabled.
- *17 D03, D05, and D08 are unused devices. On the Display, these devices show a value of 0.
- *18 The structure of address in the Alarm history device (REC) is as follows.

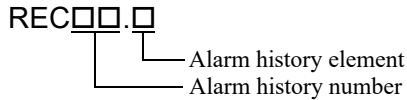

The alarm history device stores the last 50 alarms that have occurred on the External Device. Each alarm has elements such as "Cause," "Position," and "Speed" when the alarm occurred. The address identifying the element is called the "Alarm history element," and the address identifying one of the 50 historical alarms is called "Alarm history number."

The alarm history elements are listed below.

Alarm history element	Description
F	Cause
T	Total boot time
P	Position
S	Speed
M	Operation status
N	Operation point
C	elec. current
V	Voltage
I	Input
O	Output

e.g. To specify Alarm history number 10's Position (P), use "REC10.P."

- *19 Text string device. You can define up to 32 single-byte characters.
- *20 Stores RUN Alarm information for External Device operations that occurred on the Display. Even if the run alarm is removed on the External Device, the RUN Alarm information device is not cleared. Clear this information from the Display.
When you perform a new operation on the Display, the RUN Alarm information device is cleared.

NOTE

- Please refer to the GP-Pro EX Reference Manual for system data area.
Cf. GP-Pro EX Reference Manual "LS Area (Direct Access Method Area)"
- Please refer to the precautions on manual notation for icons in the table.
☞ "Manual Symbols and Terminology"

7 Device Code and Address Code

Use device code and address code when you select "Device Type & Address" for the address type in data displays.

Device		Device Name	Device Code (HEX)	Address Code
Positioning Operation		START	006F	Word address
Point Data	Retentive	POINT	0060	$((\text{Point data number} - 1) \times 12) + \text{Point data element number}^{*1}$
	Non-retentive	POINT_	0061	$((\text{Point data number} - 1) \times 12) + \text{Point data element number}^{*1}$
Parameter		K	0062	Value of word address from which 1 is deducted
Status information		D	0063	Word address
Input information		IN	0080	Word address
Output information		OUT	0081	Word address
Option information		OPT	0082	Word address
Input word information		WIN	0065	Word address
Output word information		WOUT	0066	Word address
Alarm information		ALM	0067	Value of word address from which 1 is deducted
Warning information		WARN	0068	Value of word address from which 1 is deducted
Alarm History		REC	0064	$((\text{Alarm history number} - 1) \times 10) + \text{Alarm history element number}^{*2}$
Message Information		MSG	0069	Word address
Interface Information		IF	006D	Word address
Controller Name Information		CONT	006A	Word address
Robot Name Information		ROBOT	006B	Word address
Version Information		VER	006C	Word address
RUN Alarm Information		RUNALM	0071	Word address

*1 Point data element and number is shown in the table below.

Point data element number (HEX)	Point data element	Description
0000	M	RUN type
0001	P	Position
0002	S	Speed
0003	AC	Acceleration
0004	DC	Deceleration
0005	Q	Push
0006	ZL	Zone (-)
0007	ZH	Zone (+)
0008	N	Near width
0009	J	Jump
000A	F	Flag
000B	T	Timer

*2 Alarm history element and number is shown in the table below.

Alarm history element number (HEX)	Alarm history element	Description
0000	F	Cause
0001	T	Total boot time
0002	P	Position
0003	S	Speed
0004	M	Operation status
0005	N	Operation point
0006	C	elec. current
0007	V	Voltage
0008	I	Input
0009	O	Output

8 Error Messages

Error messages are displayed on the screen of Display as follows: "No. : Device Name: Error Message (Error Occurrence Area)". Each description is shown below.

Item	Description
No.	Error No.
Device Name	Name of External Device where error occurs. Device name is a title of External Device set with GP-Pro EX. (Initial value [PLC1])
Error Message	Displays messages related to the error which occurs.
Error Occurrence Area	<p>Displays IP address or device address of External Device where error occurs, or error codes received from External Device.</p> <p>NOTE</p> <ul style="list-style-type: none"> • IP address is displayed such as "IP address (Decimal): MAC address (Hex)". • Device address is displayed such as "Address: Device address". • Received error codes are displayed such as "Decimal [Hex]".

Display Examples of Error Messages

"RHAA035: PLC1: Error has been responded for device write command (Error Code: 4 [04H])"

NOTE

- Refer to your External Device manual for details on received error codes.
- Refer to "Display-related errors" in "Maintenance/Troubleshooting Guide" for details on the error messages common to the driver.

■ Error Messages Unique to External Device

Message ID	Error Message	Description
RHxx128	(Node Name):Attempt was made to enter data that exceeded the specified range	You tried to enter a value that is outside the data range. Check the External Device manual, and write values within the setting range.
RHxx129	(Node Name):Read data exceeded the specified range	You tried to read a value that is outside the range supported by the controller. Check the External Device manual, and read values within the setting range.
RHxx130	(Node Name):Written data exceeded the specified range	You tried to enter a value that is outside the range supported by the controller. Check the External Device manual, and write values within the setting range.
RHxx131	(Node Name):Operation or edit command was executed in Monitor mode	Write command was sent while in Monitor mode. Exit Monitor mode, and then send the write command.

Message ID	Error Message	Description
RHxx132	(Node Name):Operation command was executed during operation	During an axis operation you sent the Operation command. Either wait until the axis operation completes and then send the operation command. Or, stop the axis operation and then send the operation command.
RHxx133	(Node Name):Operation command was executed during Manual mode	Operation command was sent while in Manual mode. Exit Manual mode, and then send the operation command.