



Computer Link SIO Driver

1	System Configuration.....	3
2	Selection of External Device	8
3	Example of Communication Setting.....	9
4	Setup Items.....	21
5	Cable Diagram	27
6	Supported Device.....	59
7	Device Code and Address Code.....	68
8	Error Messages.....	75

PREFACE

This manual describes how to connect the Display and the External Device.

In this manual, the connection procedure will be described by following the sections below:

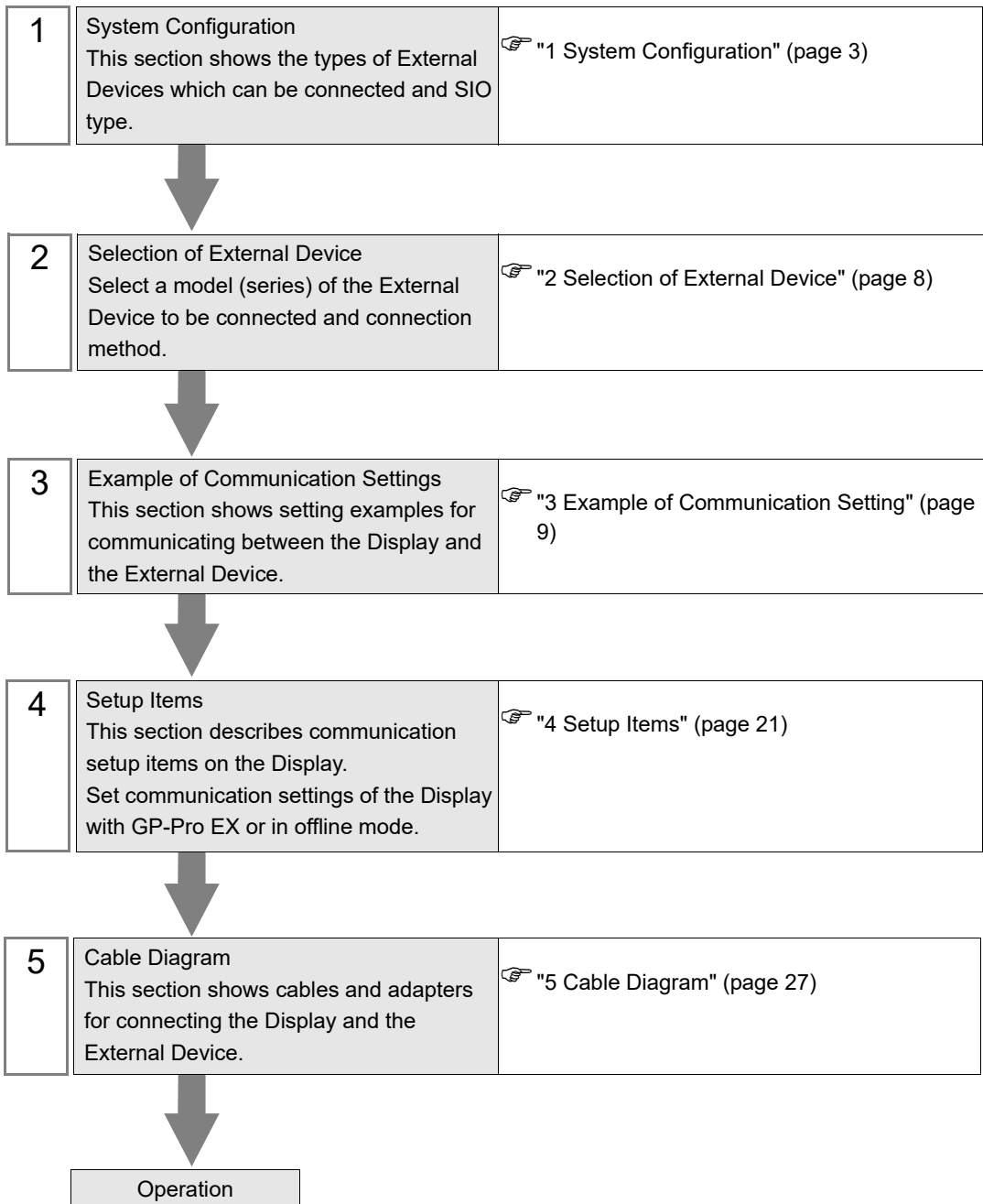

1 System Configuration

The system configuration in the case when the External Device of TOSHIBA Corporation and the Display are connected is shown.

Driver	CPU		Link I/F	SIO Type	Setting Example	Cable Diagram	
T Series	T2E		RS232C port for programming on CPU	RS232C	Setting Example 1 (page 9)	Cable Diagram 1 (page 27)	
			CM231E	RS422/485 (4wire)	Setting Example 2 (page 11)	Cable Diagram 4 (page 40)	
	T2N		RS232C/RS485 port for communication functions	RS232C	Setting Example 3 (page 13)	Cable Diagram 2 (page 29)	
			RS232C/RS485 port for communication functions	RS422/485 (4wire)	Setting Example 4 (page 15)	Cable Diagram 3 (page 31)	
	T3/T3H		RS485 port for computer link on CPU	RS422/485 (4wire)	Setting Example 2 (page 11)	Cable Diagram 3 (page 31)	
	S2T	PU662T		RS232C port for programming on CPU	RS232C	Setting Example 1 (page 9)	Cable Diagram 1 (page 27)
				Computer link port terminal block on CPU	RS422/485 (4wire)	Setting Example 2 (page 11)	Cable Diagram 4 (page 40)
		PU672T		RS232C port for programming on CPU	RS232C	Setting Example 1 (page 9)	Cable Diagram 1 (page 27)
				Computer link port terminal block on CPU	RS422/485 (4wire)	Setting Example 2 (page 11)	Cable Diagram 4 (page 40)
	S2E	PU612E		RS232C port for programming on CPU	RS232C	Setting Example 1 (page 9)	Cable Diagram 1 (page 27)
				Computer link port terminal block on CPU	RS422/485 (4wire)	Setting Example 2 (page 11)	Cable Diagram 4 (page 40)

Driver	CPU		Link I/F	SIO Type	Setting Example	Cable Diagram
V Series	Model 2000	S2PU22A S2PU32A S2PU72A S2PU72D S2PU82	RS485 port for computer link on CPU	RS422/485 (4wire)	Setting Example 5 (page 17)	Cable Diagram 4 (page 40)
	Model 3000	S3PU45A S3PU55A S3PU55B S3PU65A	RS485 port for computer link on CPU	RS422/485 (4wire)	Setting Example 5 (page 17)	Cable Diagram 5 (page 50)
EX Series	EX2000		Computer link connection pin on CPU	RS422/485 (4wire)	Setting Example 6 (page 19)	Cable Diagram 4 (page 40)

■ Connection Configuration

- 1:1 connection



- 1:n Connection

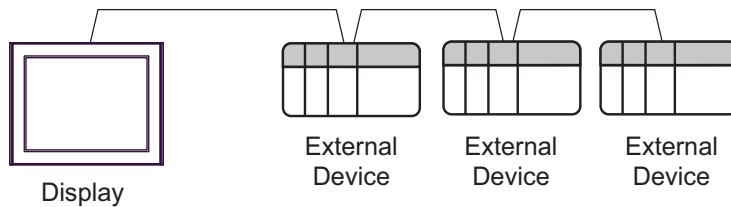

- Available to connect max 16 units
- Available to connect max 32 units by simultaneous connection of COM1 and COM2

■ IPC COM Port

When connecting IPC with an External Device, the COM port used depends on the series and SIO type. Please refer to the IPC manual for details.

Usable port

Series	Usable Port		
	RS-232C	RS-422/485(4 wire)	RS-422/485(2 wire)
PS-2000B	COM1 ^{*1} , COM2, COM3 ^{*1} , COM4	-	-
PS-3450A, PS-3451A, PS3000-BA, PS3001-BD	COM1, COM2 ^{*1*2}	COM2 ^{*1*2}	COM2 ^{*1*2}
PS-3650A (T41 model), PS-3651A (T41 model)	COM1 ^{*1}	-	-
PS-3650A (T42 model), PS-3651A (T42 model)	COM1 ^{*1*2} , COM2	COM1 ^{*1*2}	COM1 ^{*1*2}
PS-3700A (Pentium®4-M) PS-3710A	COM1 ^{*1} , COM2 ^{*1} , COM3 ^{*2} , COM4	COM3 ^{*2}	COM3 ^{*2}
PS-3711A	COM1 ^{*1} , COM2 ^{*2}	COM2 ^{*2}	COM2 ^{*2}
PS4000 ^{*3}	COM1, COM2	-	-
PL3000	COM1 ^{*1*2} , COM2 ^{*1} , COM3, COM4	COM1 ^{*1*2}	COM1 ^{*1*2}
PE-4000B Atom N270	COM1, COM2	-	-
PE-4000B Atom N2600	COM1, COM2	COM3 ^{*4} , COM4 ^{*4} , COM5 ^{*4} , COM6 ^{*4}	COM3 ^{*4} , COM4 ^{*4} , COM5 ^{*4} , COM6 ^{*4}
PS5000 (Slim Panel Type Core i3 Model) ^{*5*6}	COM1, COM2 ^{*4}	COM2 ^{*4}	COM2 ^{*4}
PS5000 (Slim Panel Type Atom Model) ^{*5*6}	COM1, COM2 ^{*7}	COM2 ^{*7}	COM2 ^{*7}
PS5000 (Enclosed Panel Type) ^{*8}	COM1	-	-
PS5000 (Modular Type PFXPU/PFXPP) ^{*5*6} PS5000 (Modular Type PFXPL2B5-6)	COM1 ^{*7}	COM1 ^{*7}	COM1 ^{*7}
PS5000 (Modular Type PFXPL2B1-4)	COM1, COM2 ^{*7}	COM2 ^{*7}	COM2 ^{*7}
PS6000 (Advanced Box) PS6000 (Standard Box)	COM1 ^{*9}	*10	*10
PS6000 (Basic Box)	COM1 ^{*9}	COM1 ^{*9}	COM1 ^{*9}

*1 The RI/5V can be switched. Use the IPC's switch to change if necessary.

*2 Set up the SIO type with the DIP Switch. Please set up as follows according to SIO type to be used.

- *3 When making communication between an External Device and COM port on the Expansion slot, only RS-232C is supported. However, ER (DTR/CTS) control cannot be executed because of the specification of COM port.
For connection with External Device, use user-created cables and disable Pin Nos. 1, 4, 6 and 9. Please refer to the IPC manual for details of pin layout.
- *4 Set up the SIO type with the BIOS. Please refer to the IPC manual for details of BIOS.
- *5 When setting up communication between an External Device and the RS-232C/422/485 interface module, use the IPC (RS-232C) or PS5000 (RS-422/485) cable diagrams. However, when using PFXZPBMPR42P2 in a RS-422/485 (4-wire) configuration with no flow control, connect 7.RTS+ and 8.CTS+, and connect 6.RTS- and 9.CTS-.
When using RS-422/485 communication with External Devices, you may need to reduce the transmission speed and increase the TX Wait time.
- *6 To use RS-422/485 communication on the RS-232C/422/485 interface module, the DIP Switch setting is required. Please refer to "Knowledge Base" (FAQs) on the support site. (<http://www.pro-face.com/trans/en/manual/1001.html>)

Settings	FAQ ID
PFXZPBMPR42P2, RS422/485 change method	FA263858
PFXZPBMPR42P2 termination resistor setting	FA263974
PFXZPBMPR44P2, RS422/485 change method	FA264087
PFXZPBMPR44P2 termination resistor setting	FA264088

- *7 Set up the SIO type with the DIP Switch. Please refer to the IPC manual for details of DIP Switch. The BOX Atom has not a switch to set the RS-232C, RS-422/485 mode. Use the BIOS for the setting.
- *8 For the connection with the External Device, on the user-created cable read as if the connector on the Display-side is a M12 A-coding 8 pin socket. The pin assignment is the same as described in the cable diagram. For the M12 A-coding connector, use PFXZPSCNM122.
- *9 In addition to COM1, you can also use the COM port on the optional interface.
- *10 Install the optional interface in the expansion slot.

DIP Switch settings (PL3000 / PS3000 Series)

RS-232C

DIP Switch	Setting	Description
1	OFF*1	Reserved (always OFF)
2	OFF	SIO type: RS-232C
3	OFF	
4	OFF	Output mode of SD (TXD) data: Always output
5	OFF	Terminal resistance (220Ω) insertion to SD (TXD): None
6	OFF	Terminal resistance (220Ω) insertion to RD (RXD): None
7	OFF	Short-circuit of SDA (TXA) and RDA (RXA): Not available
8	OFF	Short-circuit of SDB (TXB) and RDB (RXB): Not available
9	OFF	RS (RTS) Auto control mode: Disabled
10	OFF	

*1 When using PS-3450A, PS-3451A, PS3000-BA and PS3001-BD, turn ON the set value.

RS-422/485 (4 wire)

DIP Switch	Setting	Description
1	OFF	Reserved (always OFF)
2	ON	SIO type: RS-422/485
3	ON	
4	OFF	Output mode of SD (TXD) data: Always output
5	OFF	Terminal resistance (220Ω) insertion to SD (TXD): None
6	OFF	Terminal resistance (220Ω) insertion to RD (RXD): None
7	OFF	Short-circuit of SDA (TXA) and RDA (RXA): Not available
8	OFF	Short-circuit of SDB (TXB) and RDB (RXB): Not available
9	OFF	RS (RTS) Auto control mode: Disabled
10	OFF	

RS-422/485 (2 wire)

DIP Switch	Setting	Description
1	OFF	Reserved (always OFF)
2	ON	SIO type: RS-422/485
3	ON	
4	OFF	Output mode of SD (TXD) data: Always output
5	OFF	Terminal resistance (220Ω) insertion to SD (TXD): None
6	OFF	Terminal resistance (220Ω) insertion to RD (RXD): None
7	ON	Short-circuit of SDA (TXA) and RDA (RXA): Available
8	ON	Short-circuit of SDB (TXB) and RDB (RXB): Available
9	ON	RS (RTS) Auto control mode: Enabled
10	ON	

2 Selection of External Device

Select the External Device to be connected to the Display.

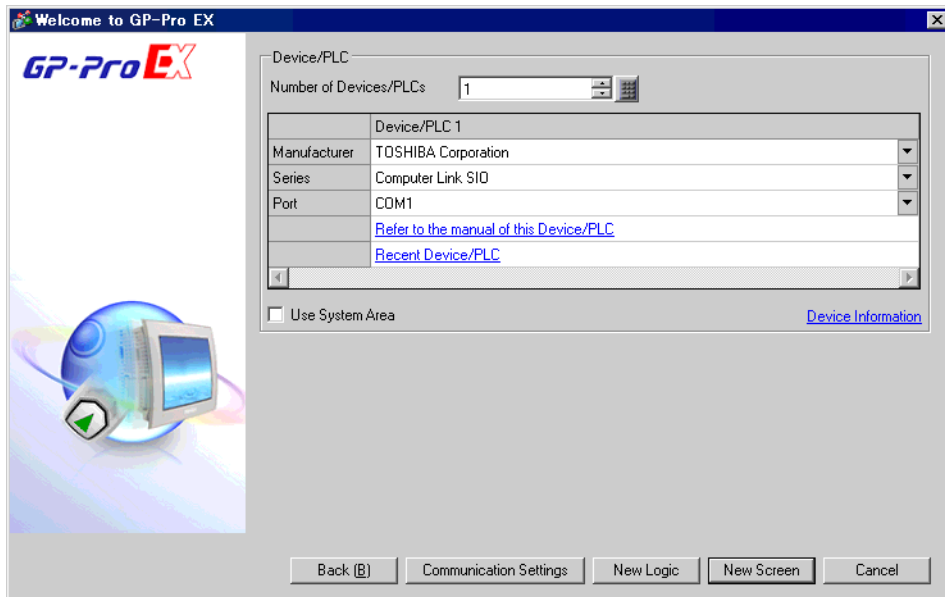

Setup Items	Setup Description
Number of Devices/PLCs	Enter an integer from 1 to 4 to define the number of Devices/PLCs to connect to the display.
Manufacturer	Select the manufacturer of the External Device to connect. Select "TOSHIBA Corporation".
Series	Select the External Device model (series) and the connection method. Select "Computer Link SIO". In System configuration, make sure the External Device you are connecting is supported by "Computer Link SIO". ☞ "1 System Configuration" (page 3)
Port	Select the Display port to connect to the External Device.
Use System Area	Check this option to synchronize the system data area of the Display and the device (memory) of the External Device. When synchronized, you can use the External Device's ladder program to switch the display or display the window on the Display. Cf. GP-Pro EX Reference Manual "LS Area (Direct Access Method Area)" This feature can also be set in GP-Pro EX or in the Display's offline mode. Cf. GP-Pro EX Reference Manual "System Settings [Display Unit] - [System Area] Settings Guide" Cf. Maintenance/Troubleshooting Guide "Main Unit - System Area Settings"

3 Example of Communication Setting

The following shows examples of communication settings of the Display and the External Device, which is recommended by Digital Electronics Corp.

3.1 Setting Example 1

■ Settings of GP-Pro EX

◆ Communication Settings

To display the setup screen, from the [Project] menu, point to [System Settings] and select [Device/PLC].

Device/PLC 1

Summary [Change Device/PLC](#)

Manufacturer Series Port

Text Data Mode [Change](#)

Communication Settings

SIO Type RS232C RS422/485(2wire) RS422/485(4wire)

Speed

Data Length 7 8

Parity NONE EVEN ODD

Stop Bit 1 2

Flow Control NONE ER(DTR/CTS) XON/XOFF

Timeout (sec)

Retry

Wait To Send (ms)

RI / VCC RI VCC
In the case of RS232C, you can select the 9th pin to RI (Input) or VCC (5V Power Supply). If you use the Digital's RS232C Isolation Unit, please select it to VCC.

Device-Specific Settings

Allowable Number of Devices/PLCs [Add Device](#)

No.	Device Name	Settings
<input type="button" value="Add"/> 1	<input type="text" value="PLC1"/>	<input type="text" value="Series=T Series, Station No.=1"/>

◆ Device Setting

To display the [Individual Device Settings] dialog box, from [Device-Specific Settings] in the [Device/PLC] window, select the external device and click [Settings]  .

Individual Device Settings

PLC1

Series T Series V Series EX Series

Please reconfirm all of address settings that you are using if you have changed the series.

Station No.

■ Settings of External Device

Use the ladder software (T-PDS for Windows) for communication settings. Please refer to the manual of the External Device for more details.

- 1 Start up the ladder software.
- 2 Select [Online/Offline] from the [PLC] menu and move to the online mode.
- 3 Select [I/O assign information]-[General I/O assign information] from the [PLC] menu.
- 4 Click [Auto assign] and register the input module installed in the slot, then click [OK].
- 5 Select [System information] from the [PLC] menu and click [Computer link settings].
- 6 Enter "1" in [Station No.] and click [Connection parameter].
- 7 Set as shown below in the connection type dialog box and click [OK].

Item Name	Settings
Baud Rate	9600
Parity	Odd
Data Length	8
Stop Bit	1

- 8 When the write confirmation message appears, click [OK].
The communication settings are completed.

3.2 Setting Example 2

■ Settings of GP-Pro EX

◆ Communication Settings

To display the setup screen, from the [Project] menu, point to [System Settings] and select [Device/PLC].

Device/PLC 1

Summary [Change Device/PLC](#)

Manufacturer Series Port

Text Data Mode [Change](#)

Communication Settings

SIO Type RS232C RS422/485(2wire) RS422/485(4wire)

Speed

Data Length 7 8

Parity NONE EVEN ODD

Stop Bit 1 2

Flow Control NONE ER(DTR/CTS) XON/XOFF

Timeout (sec)

Retry

Wait To Send (ms)

RI / VCC RI VCC

In the case of RS232C, you can select the 9th pin to RI (Input or VCC (5V Power Supply)). If you use the Digital's RS232C Isolation Unit, please select it to VCC.

Device-Specific Settings

Allowable Number of Devices/PLCs [Add Device](#)

No.	Device Name	Settings
<input type="button" value="1"/>	<input type="text" value="PLC1"/>	<input type="text" value="Series=T Series, Station No.=1"/>

◆ Device Setting

To display the [Individual Device Settings] dialog box, from [Device-Specific Settings] in the [Device/PLC] window, select the external device and click [Settings]  .

Individual Device Settings

PLC1

Series T Series V Series EX Series

Please reconfirm all of address settings that you are using if you have changed the series.

Station No.

■ Settings of External Device

Use the ladder software (T-PDS for Windows) for communication settings. Please refer to the manual of the External Device for more details.

- 1 Start up the ladder software.
- 2 Select [Online/Offline] from the [PLC] menu and move to the online mode.
- 3 Select [I/O assign information]-[General I/O assign information] from the [PLC] menu.
- 4 Click [Auto assign] and register the input module installed in the slot, then click [OK].
- 5 Select [System information] from the [PLC] menu and click [Computer link settings].
- 6 Enter "1" in [Station No.] and click [Connection parameter].
- 7 Set as shown below in the connection type dialog box and click [OK].

Item Name	Settings
Baud Rate	9600
Parity	Odd
Data Length	8
Stop Bit	1

- 8 When the write confirmation message appears, click [OK].
The communication settings are completed.

3.3 Setting Example 3

■ Settings of GP-Pro EX

◆ Communication Settings

To display the setup screen, from the [Project] menu, point to [System Settings] and select [Device/PLC].

Device/PLC 1

Summary [Change Device/PLC](#)

Manufacturer Series Port

Text Data Mode [Change](#)

Communication Settings

SIO Type RS232C RS422/485(2wire) RS422/485(4wire)

Speed

Data Length 7 8

Parity NONE EVEN ODD

Stop Bit 1 2

Flow Control NONE ER(DTR/CTS) XON/XOFF

Timeout (sec)

Retry

Wait To Send (ms)

RI / VCC RI VCC

In the case of RS232C, you can select the 9th pin to RI (Input) or VCC (5V Power Supply). If you use the Digital's RS232C Isolation Unit, please select it to VCC.

Device-Specific Settings

Allowable Number of Devices/PLCs 16 [Add Device](#)

No.	Device Name	Settings
<input type="button" value="1"/>	<input type="text" value="PLC1"/>	<input type="text" value="Series=T Series,Station No.=1"/>

◆ Device Setting

To display the [Individual Device Settings] dialog box, from [Device-Specific Settings] in the [Device/PLC] window, select the external device and click [Settings]  .

Individual Device Settings

PLC1

Series T Series V Series EX Series

Please reconfirm all of address settings that you are using if you have changed the series.

Station No.

■ Settings of External Device

Use the DIP switch on the board and the ladder software (T-PDS for Windows) for communication settings.

Please refer to the manual of the External Device for more details.

◆ DIP Switch (on the board) Settings

SW	Settings	Setup Description
01	ON	RS232C
02	OFF	

◆ Ladder Software Setting

- 1 Start up the ladder software.
- 2 Select [Online/Offline] from the [PLC] menu and move to the online mode.
- 3 Select [I/O assign information]-[General I/O assign information] from the [PLC] menu.
- 4 Click [Auto assign] and register the input module installed in the slot, then click [OK].
- 5 Select [System information] from the [PLC] menu and click [Computer link settings].
- 6 Enter "1" in [Station No.] and click [Connection parameter].
- 7 Set as shown below in the connection type dialog box and click [OK].

Item Name	Settings
Baud Rate	9600
Parity	Odd
Data Length	8
Stop Bit	1

- 8 When the write confirmation message appears, click [OK].

The communication settings are completed.

3.4 Setting Example 4

■ Settings of GP-Pro EX

◆ Communication Settings

To display the setup screen, from the [Project] menu, point to [System Settings] and select [Device/PLC].

Device/PLC 1

Summary [Change Device/PLC](#)

Manufacturer Series Port

Text Data Mode [Change](#)

Communication Settings

SIO Type RS232C RS422/485(2wire) RS422/485(4wire)

Speed

Data Length 7 8

Parity NONE EVEN ODD

Stop Bit 1 2

Flow Control NONE ER(DTR/CTS) XON/XOFF

Timeout (sec)

Retry

Wait To Send (ms)

RI / VCC RI VCC

In the case of RS232C, you can select the 9th pin to RI (Input or VCC (5V Power Supply). If you use the Digital's RS232C Isolation Unit, please select it to VCC.

Device-Specific Settings

Allowable Number of Devices/PLCs [Add Device](#)

No.	Device Name	Settings
<input type="button" value="1"/>	<input type="text" value="PLC1"/>	<input type="text" value="Series=T Series, Station No.=1"/>

◆ Device Setting

To display the [Individual Device Settings] dialog box, from [Device-Specific Settings] in the [Device/PLC] window, select the external device and click [Settings]  .

Individual Device Settings

PLC1

Series T Series V Series EX Series

Please reconfirm all of address settings that you are using if you have changed the series.

Station No.

■ Settings of External Device

Use the DIP switch on the board and the ladder software (T-PDS for Windows) for communication settings.

Please refer to the manual of the External Device for more details.

◆ DIP Switch (on the board) Settings

SW	Settings	Description
01	OFF	RS422
02	OFF	

◆ Ladder Software Setting

- 1 Start up the ladder software.
- 2 Select [Online/Offline] from the [PLC] menu and move to the online mode.
- 3 Select [I/O assign information]-[General I/O assign information] from the [PLC] menu.
- 4 Click [Auto assign] and register the input module installed in the slot, then click [OK].
- 5 Select [System information] from the [PLC] menu and click [Computer link settings].
- 6 Enter "1" in [Station No.] and click [Connection parameter].
- 7 Set as shown below in the connection type dialog box and click [OK].

Item Name	Settings
Baud Rate	9600
Parity	Odd
Data Length	8
Stop Bit	1

- 8 When the write confirmation message appears, click [OK].

The communication settings are completed.

3.5 Setting Example 5

■ Settings of GP-Pro EX

◆ Communication Settings

To display the setup screen, from the [Project] menu, point to [System Settings] and select [Device/PLC].

Device/PLC 1

Summary [Change Device/PLC](#)

Manufacturer Series Port

Text Data Mode [Change](#)

Communication Settings

SIO Type RS232C RS422/485(2wire) RS422/485(4wire)

Speed

Data Length 7 8

Parity NONE EVEN ODD

Stop Bit 1 2

Flow Control NONE ER(DTR/CTS) XON/XOFF

Timeout (sec)

Retry

Wait To Send (ms)

RI / VCC RI VCC

In the case of RS232C, you can select the 9th pin to RI (Input or VCC (5V Power Supply). If you use the Digital's RS232C Isolation Unit, please select it to VCC.

Device-Specific Settings

Allowable Number of Devices/PLCs [Add Device](#)

No.	Device Name	Settings
<input type="button" value="1"/>	<input type="text" value="PLC1"/>	<input type="text" value="Series=V Series, Station No.=1"/>

◆ Device Setting

To display the [Individual Device Settings] dialog box, from [Device-Specific Settings] in the [Device/PLC] window, select the external device and click [Settings]  .

Individual Device Settings

PLC1

Series T Series V Series EX Series

Please reconfirm all of address settings that you are using if you have changed the series.

Station No.

■ Settings of External Device

Use the ladder software (V Series engineering tool 3) for communication settings. Please refer to the manual of the External Device for more details.

- 1 Start up the product manager of "V Series engineering tool 3 (for administration)" and specify the user product path.
- 2 Click [Login security setting]. Enter [User name] and [Password], and click [OK].
- 3 Start up the ladder software. Right-click on the "System" folder and select [New].
- 4 Enter [System name] and click [OK]. The system with the entered name is created in the "System" folder.
- 5 Double-click the system name.
- 6 Right-click on the "Station" folder among the three created folders ("Library", "Network", "Station"), and select [New].
- 7 Enter the station name and select the station model name. Then, click [OK].
- 8 Right-click on the "Unit" folder created in the "Station" folder, and select [New].
- 9 Enter "0" in [Unit No] and select your unit base model from [Unit model name].
- 10 Right-click on the "Module" folder under the "Unit" folder, and select [New].
- 11 Enter "0" in [Slot No] and select your module model from [Module model name]. Then, click [OK].
- 12 Right-click on the CPU module and select [Module parameter].
- 13 Set as shown below in the module parameter dialog box and click [Update].

Item Name	Settings
RS485 Station No	1
RS485 Transmission Speed (bit/s)	9600
RS485 Parity Setting	Odd
RS485 Data Length	8 bits
RS485 Stop Bit	1 bit

- 14 Click [Close] and close the module parameter dialog box.
- 15 Configure the transfer setting and collectively download the communication settings you have set in the ladder software to the External Device.

The communication settings are completed.

3.6 Setting Example 6

■ Settings of GP-Pro EX

◆ Communication Settings

To display the setup screen, from the [Project] menu, point to [System Settings] and select [Device/PLC].

Device/PLC 1

Summary [Change Device/PLC](#)

Manufacturer Series Port

Text Data Mode [Change](#)

Communication Settings

SIO Type RS232C RS422/485(2wire) RS422/485(4wire)

Speed

Data Length 7 8

Parity NONE EVEN ODD

Stop Bit 1 2

Flow Control NONE ER(DTR/CTS) XON/XOFF

Timeout (sec)

Retry

Wait To Send (ms)

RI / VCC RI VCC

In the case of RS232C, you can select the 9th pin to RI (Input or VCC (5V Power Supply). If you use the Digital's RS232C Isolation Unit, please select it to VCC.

Device-Specific Settings

Allowable Number of Devices/PLCs 16 [Add Device](#)

No.	Device Name	Settings
1	PLC1	Series=EX Series, Station No.=1

◆ Device Setting

To display the [Individual Device Settings] dialog box, from [Device-Specific Settings] in the [Device/PLC] window, select the external device and click [Settings]  .

Individual Device Settings

PLC1

Series T Series V Series EX Series

Please reconfirm all of address settings that you are using if you have changed the series.

Station No.

■ Settings of External Device

Use the RAM-6624 key switch, rotary switch and ladder software (EX-PDS/SDT) for communication settings.

Please refer to the manual of the External Device for more details.

◆ Key Switch Settings

Key Switch	Settings	Description
PROGRAM	OFF	Available for both read/write
DATA	OFF	

◆ Rotary Switch Settings

Rotary Switch	Settings	Description
Data protect	0	Without protect

◆ Ladder Software Setting

- 1 Start up the ladder software.
- 2 Select [F5 (ENVIRONMENTAL INFORMATION)] on the menu screen.
- 3 Select [F1 (COMMUNICATION TARGET)] on the ENVIRONMENTAL INFORMATION screen.
- 4 In the EDIT mode, use the [Prev]key and [Next]key to display [EX2000] for "1. PC TYPE" at the bottom of the screen, and select [F4 (EX2000 16K)].
- 5 Move the cursor on [COMMUNICATION METHOD] and select [F4 (CLOOP)].
(When ERR is displayed on the upper left screen, press the [Shift] key + [F1] and select [CLEAR ERRRST] using [F8]. After that, press the [Enter] key and release the ERR display.)
- 6 When you press [F1 SETUP], "CONFIRM>ENT" is displayed on the upper right. Press the [Enter] key.
- 7 If there is no error, "COMPLETE" is displayed. Then, repeatedly press the [Shift]key + [F10] three times to return to the original menu screen.
- 8 Select [F1 (SYSTEM AND CONTROL INFORMATION)] on the menu screen.
- 9 Select [F1 (SYSTEM INFORMATION)] on the SYSTEM AND CONTROL INFORMATION screen.
- 10 On the SYSTEM INFORMATION screen, select [F1 (EDIT)] first, then [F2 (NEXT)].
- 11 Set as shown below in the COMPUTER LINK setting.

Item Name	Settings
STATION NO.	01
BAUD RATE	9600 (bps)
PARITY	1
DATA LENGTH	8 (bit)
STOP BIT	1 (bit)

- 12 When you select [F1 (PROG)], "CONFIRM>ENT" is displayed. Press the [Enter] key.
- 13 The communication settings are completed.
Press the [Esc] key to display "CONFIRM>ENT". Press the [Enter] key to return to the menu screen.

4 Setup Items

Set communication settings of the Display with GP-Pro Ex or in offline mode of the Display.

The setting of each parameter must be identical to that of the External Device.

 "3 Example of Communication Setting" (page 9)

4.1 Setup Items in GP-Pro EX

■ Communication Settings

To display the setup screen, from the [Project] menu, point to [System Settings] and select [Device/PLC].

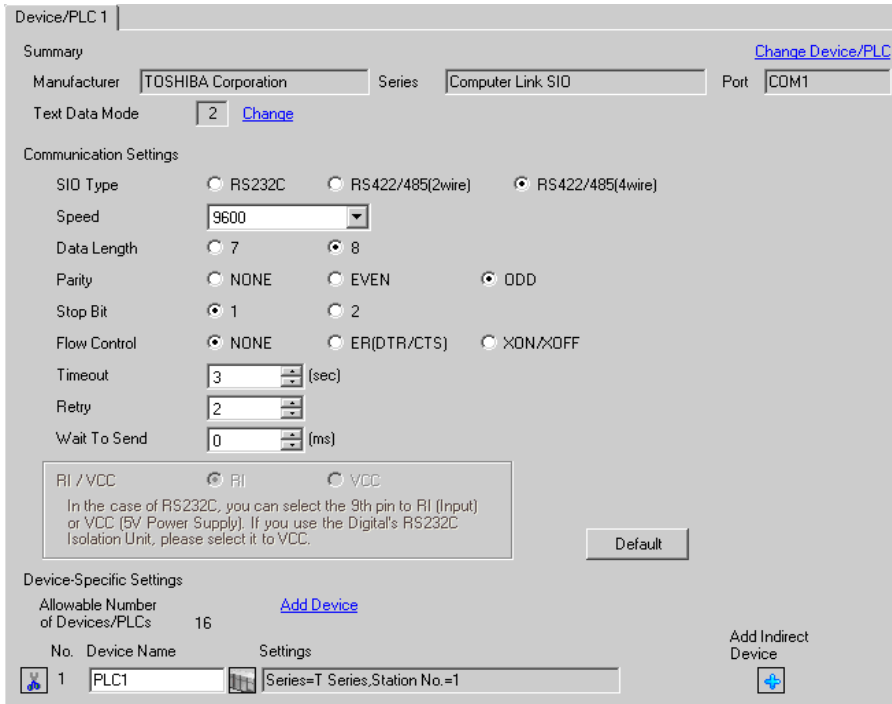

Setup Items	Setup Description
SIO Type	Select the SIO type to communicate with the External Device.
Speed	Select the communication speed between the External Device and the Display.
Data Length	Select data length.
Parity	Select how to check parity.
Stop Bit	Select stop bit length.
Flow Control	Select the communication control method to prevent overflow of transmission and reception data.
Timeout	Use an integer from 1 to 127 to enter the time (s) for which the Display waits for the response from the External Device.

Continued to next page.

Setup Items	Setup Description
Retry	In case of no response from the External Device, use an integer from "0 to 255" to enter how many times the Display retransmits the command.
Wait To Send	Use an integer from "0 to 255" to enter standby time (ms) for the Display from receiving packets to transmitting next commands.
RI/VCC	You can switch RI/VCC of the 9th pin when you select RS232C for SIO type. When you connect to IPC, you need to use the IPC change switch to change RI/5V. Please refer to the manual of IPC for details.

NOTE • Refer to the GP-Pro EX Reference Manual for Indirect Device.

Cf. GP-Pro EX Reference Manual "Changing the Device/PLC at Runtime (Indirect Device)"

■ Device Setting

To display the [Individual Device Settings] dialog box, from [Device-Specific Settings] in the [Device/PLC] window, select the external device and click [Settings] .

To connect multiple External Devices, from [Device-Specific Settings] in the [Device/PLC] window, click [Add Device] to add another External Device.



Setup Items	Setup Description
Series	Select the series of the External Device.
StationNo.	Enter the unit No. of the External Device with "1 to 32".

4.2 Settings in Offline Mode

NOTE

- Refer to the Maintenance/Troubleshooting guide for information on how to enter offline mode or about the operation.

Cf. Maintenance/Troubleshooting Guide "Offline Mode"

- The number of the setup items to be displayed for 1 page in the offline mode depends on the Display in use. Please refer to the Reference manual for details.

■ Communication Settings

To display the setting screen, touch [Device/PLC Settings] from [Peripheral Equipment Settings] in the offline mode. Touch the External Device you want to set from the displayed list.

Comm.	Device	Option		
Computer Link SIO		[COM1]	Page 1/1	
SIO Type	RS422/485(4wire)			
Speed	9600			
Data Length	<input type="radio"/> 7 <input checked="" type="radio"/> 8			
Parity	<input type="radio"/> NONE <input type="radio"/> EVEN <input checked="" type="radio"/> ODD			
Stop Bit	<input checked="" type="radio"/> 1 <input type="radio"/> 2			
Flow Control	NONE			
Timeout(s)	3			
Retry	2			
Wait To Send(ms)	0			
Exit		Back		2007/03/09 21:17:33

Setup Items	Setup Description
SIO Type	Select the SIO type to communicate with the External Device. IMPORTANT In the communication setting, confirm the serial interface specifications of the Display and set [SIO Type] correctly. If you select the SIO type the serial interface does not support, we cannot guarantee the operation. Please refer to the manual of the Display for more detail on the serial interface specifications.
Speed	Select the communication speed between the External Device and the Display.
Data Length	Select data length.
Parity	Select how to check parity.

Setup Items	Setup Description
Stop Bit	Select stop bit length.
Flow Control	Select the communication control method to prevent overflow of transmission and reception data.
Timeout	Use an integer from 1 to 127 to enter the time (s) for which the Display waits for the response from the External Device.
Retry	In case of no response from the External Device, use an integer from "0 to 255" to enter how many times the Display retransmits the command.
Wait To Send	Use an integer from "0 to 255" to enter standby time (ms) for the Display from receiving packets to transmitting next commands.

■ Device Setting

To display the setting screen, touch [Device/PLC Settings] from [Peripheral Equipment Settings]. Touch the External Device you want to set from the displayed list, and touch [Device Settings].

Comm.	Device	Option		
Computer Link SIO			[COM1]	Page 1/1
Device/PLC Name	PLC1 <input type="text"/>			
Series	T Series			
Station No.	<input type="text" value="1"/> <input type="button" value="▼"/> <input type="button" value="▲"/>			
	Exit		Back	2007/03/09 21:17:37

Setup Items	Setup Description
Device/PLC Name	Select the External Device to set. Device name is a title of the External Device set with GP-Pro EX. (Initial value [PLC1])
StationNo.	Enter the station No. of the External Device with "1 to 32".

■ Option

To display the setting screen, touch [Device/PLC Settings] from [Peripheral Equipment Settings]. Touch the External Device you want to set from the displayed list, and touch [Option].

Comm.	Device	Option		
Computer Link SIO		[COM1]	Page 1/1	
RI / VCC <input checked="" type="radio"/> RI <input type="radio"/> VCC In the case of RS232C, you can select the 9th pin to RI(Input) or VCC(5V Power Supply). If you use the Digital's RS232C Isolation Unit, please select it to VCC.				
Exit		Back		2007/03/09 21:17:44

Setup Items	Setup Description
RI/VCC	You can switch RI/VCC of the 9th pin when you select RS232C for SIO type. When you connect to IPC, you need to use the IPC change switch to change RI/5V. Please refer to the manual of IPC for details.

NOTE

- GP-4100 series, GP-4*01TM and GP-Rear Module do not have the [Option] setting in the offline mode.

5 Cable Diagram

The cable diagram shown below may be different from the cable diagram recommended by TOSHIBA Corporation. Please be assured there is no operational problem in applying the cable diagram shown in this manual.

- The FG pin of the main body of the External Device must be D-class grounded. Please refer to the manual of the External Device for more details.
- SG and FG are connected inside the Display. When connecting SG to the External Device, design the system not to form short-circuit loop.
- If the communication is not stable due to the noise or other factors, connect the isolation unit.

Cable Diagram 1

Display (Connection Port)	Cable		Remarks
GP3000 (COM1) GP4000* ¹ (COM1) SP5000* ² (COM1/2) SP-5B00 (COM1) ST3000 (COM1) ST6000 (COM1) STM6000 (COM1) STC6000 (COM1) ET6000 (COM1) LT3000 (COM1) IPC* ³ PC/AT	1A	Your own cable	Cable length: 15m or less
GP-4115T (COM1) GP-4115T3 (COM1)	1B	Your own cable	Cable length: 15m or less

*1 All GP4000 models except GP-4100 Series and GP-4203T

*2 Except SP-5B00

*3 Available to use only the COM ports which can communicate in RS232C.
 ■ IPC COM Port (page 5)

1A)

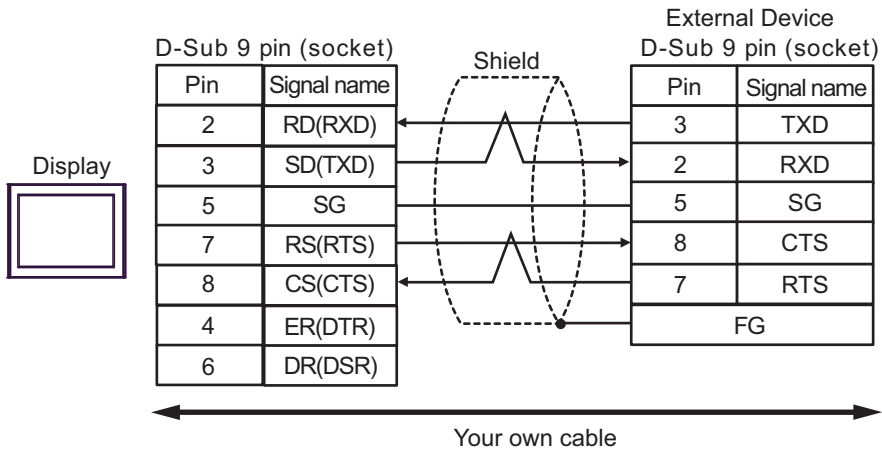

1B)

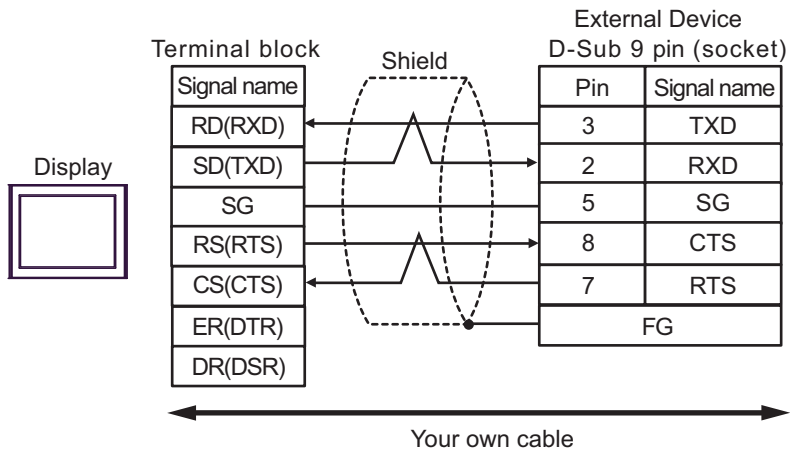

Cable Diagram 2

Display (Connection Port)	Cable		Remarks
GP3000 (COM1) GP4000* ¹ (COM1) SP5000* ² (COM1/2) SP-5B00 (COM1) ST3000 (COM1) ST6000 (COM1) STM6000 (COM1) STC6000 (COM1) ET6000 (COM1) LT3000 (COM1) IPC* ³ PC/AT	2A	Your own cable	Cable length: 15m or less
GP-4115T (COM1) GP-4115T3 (COM1)	2B	Your own cable	Cable length: 15m or less

*1 All GP4000 models except GP-4100 Series and GP-4203T

*2 Except SP-5B00

*3 Available to use only the COM ports which can communicate in RS232C.
 ■ IPC COM Port (page 5)

2A)

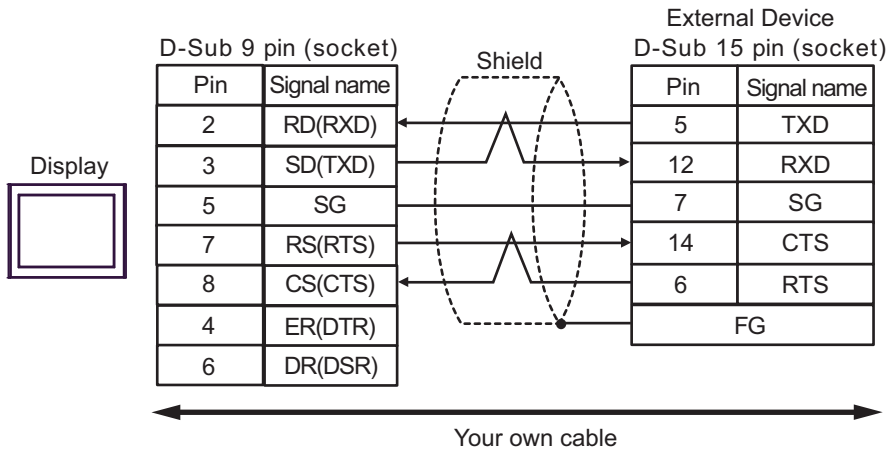

2B)

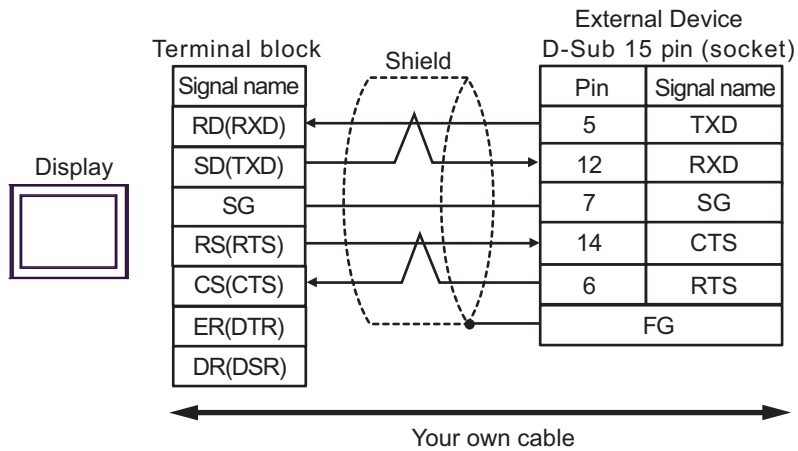

Cable Diagram 3

Display (Connection Port)	Cable		Remarks
GP3000* ¹ (COM1) AGP-3302B(COM2) GP-4*01TM (COM1) GP-Rear Module (COM1) ST3000* ² (COM2) LT3000 (COM1) IPC* ³	3A	COM port conversion adapter by Digital Electronics Corp. CA3-ADPCOM-01 + Connector terminal block conversion adapter by Digital Electronics Corp. CA3-ADPTRM-01 + Your own cable	Cable length: 1,000m or less
	3B	Your own cable	
GP3000* ⁴ (COM2)	3C	Online adapter by Digital Electronics Corp. CA4-ADPONL-01 + Connector terminal block conversion adapter by Digital Electronics Corp. CA3-ADPTRM-01 + Your own cable	Cable length: 1,000m or less
	3D	Online adapter by Digital Electronics Corp. CA4-ADPONL-01 + Your own cable	
GP-4116T (COM1)	3G	Your own cable	Cable length: 1,000m or less
GP4000* ⁵ (COM2) GP-4201T (COM1) SP5000* ⁶ (COM1/2) SP-5B00 (COM2) ST6000* ⁷ (COM2) ST-6200 (COM1) STM6000 (COM1) STC6000 (COM1) ET6000* ⁸ (COM2) PS6000 (Basic Box) (COM1/2)	3E	RS-422 terminal block conversion adapter by Digital Electronics Corp. PFXZCBADTM1* ⁹ + Your own cable	Cable length: 1,000m or less
	3B	Your own cable	
PE-4000B* ¹⁰ PS5000* ¹⁰ PS6000 (Optional Interface)* ¹⁰	3F	Your own cable	Cable length: 1,000m or less

*1 All GP models except AGP-3302B

*2 Except AST-3211A and AST-3302B

*3 Available to use only the COM ports which can communicate in RS422/485(4 wire). (Except PE-4000B, PS5000, and PS6000)

☞ ■ IPC COM Port (page 5)

*4 All GP models except GP-3200 Series and AGP-3302B

*5 All GP4000 models except GP-4100 series, GP-4*01TM, GP-Rear Module, GP-4201T and GP-4*03T

*6 Except SP-5B00

*7 Except ST-6200

*8 Due to the COM port specifications, flow control is not possible. Omit wiring the control pins on the Display side of the cable diagram.

- *9 When using a Terminal Block Conversion Adapter (CA3-ADPTRM-01) instead of the RS-422 Terminal Block Conversion Adapter, refer to Cable Diagram 3A.
- *10 Available to use only the COM ports which can communicate in RS422/485(4 wire).
☞ ■ IPC COM Port (page 5)

3A)

- 1:1 Connection

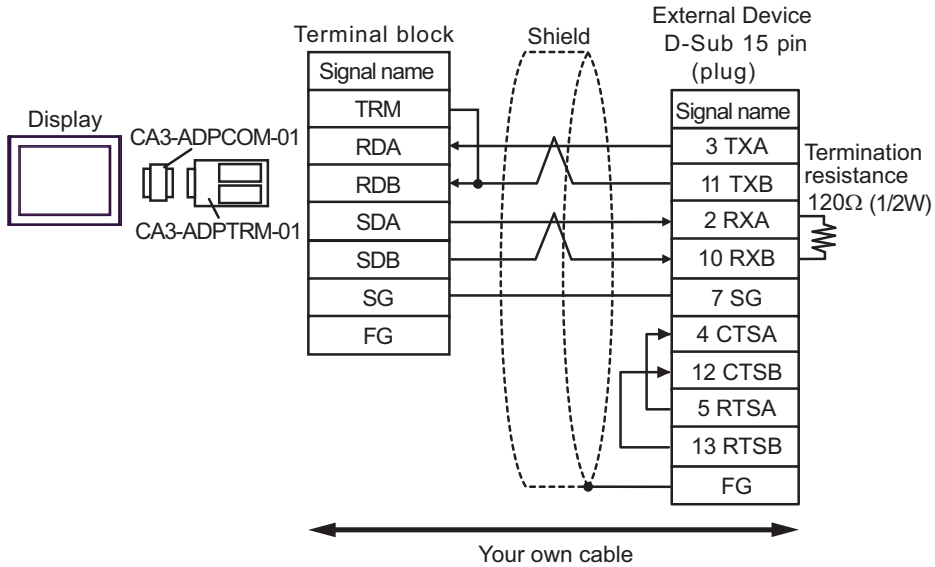

- 1:n Connection

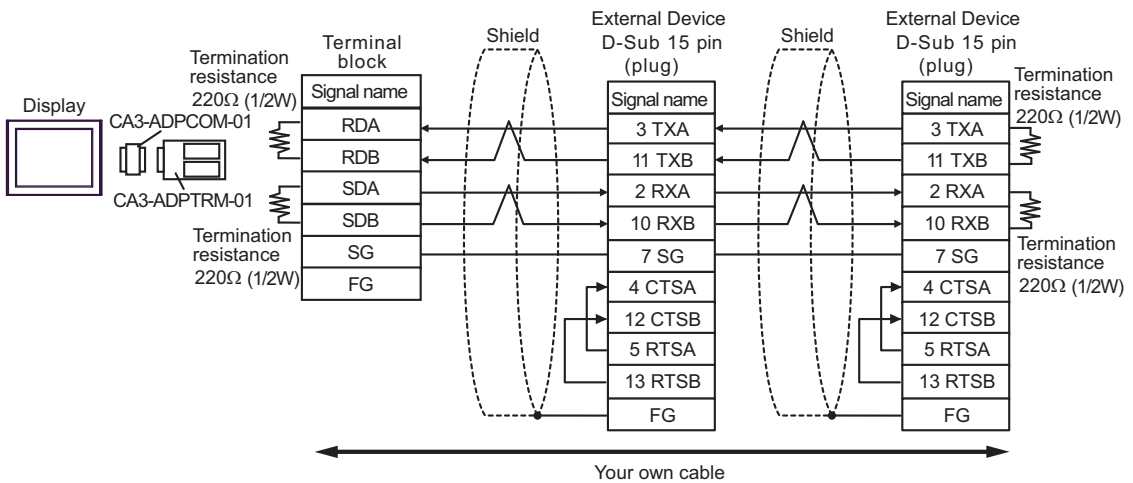

NOTE • When IPC is used as the Display, the terminal resistance of 220Ω can be inserted by the fact that the dip switch 5, 6 of IPC is turned to ON.

3B)

- 1:1 Connection

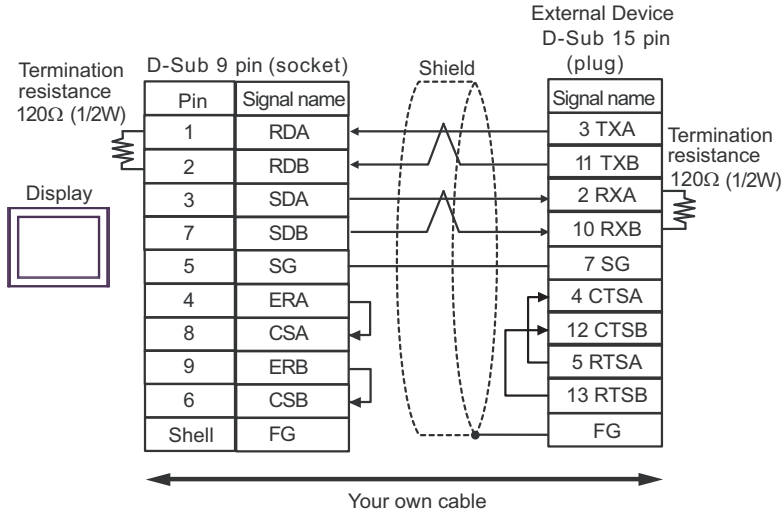

- 1:n Connection

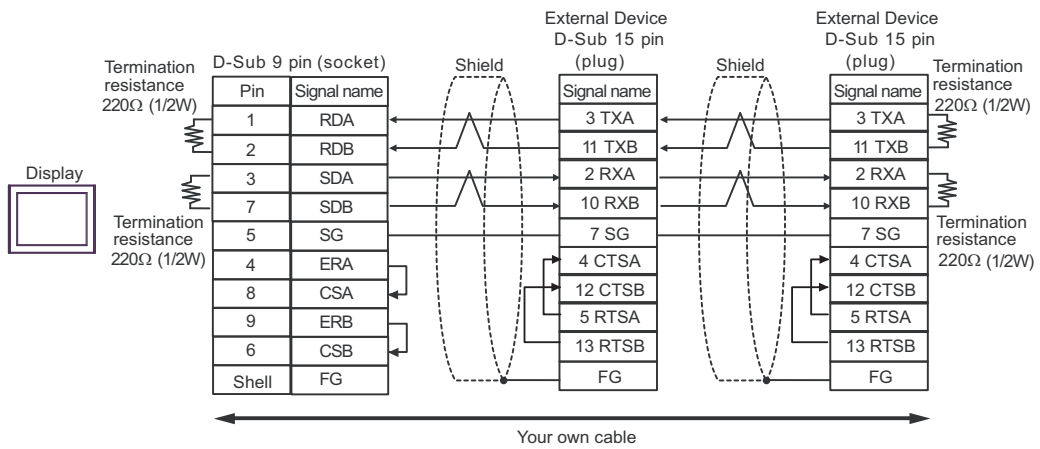

NOTE

- We recommend CO-SPEV-SB(A)3P*0.5 by Hitachi Cable, Ltd. for the connection cable.
- When IPC is used as the Display, the terminal resistance of 220Ω can be inserted by the fact that the dip switch 5, 6 of IPC is turned to ON.

3C)

- 1:1 Connection

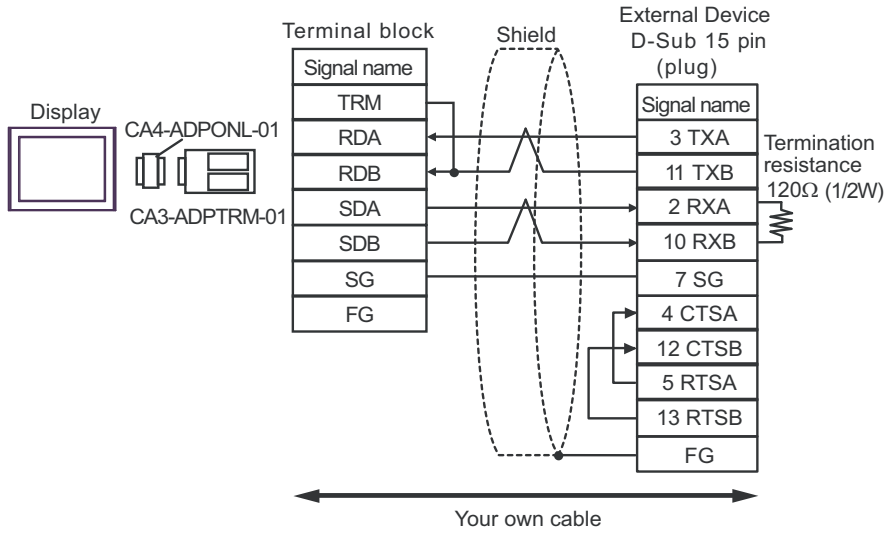

- 1:n Connection

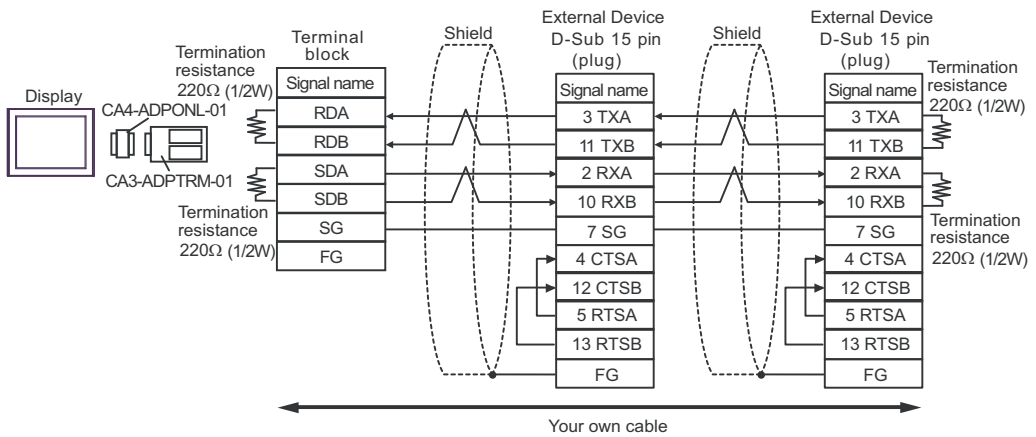

3D)

- 1:1 Connection

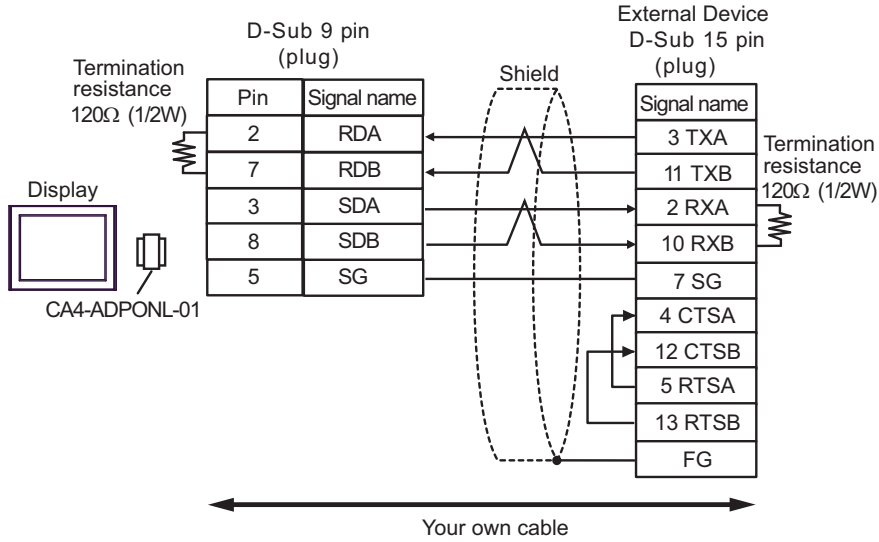

- 1:n Connection

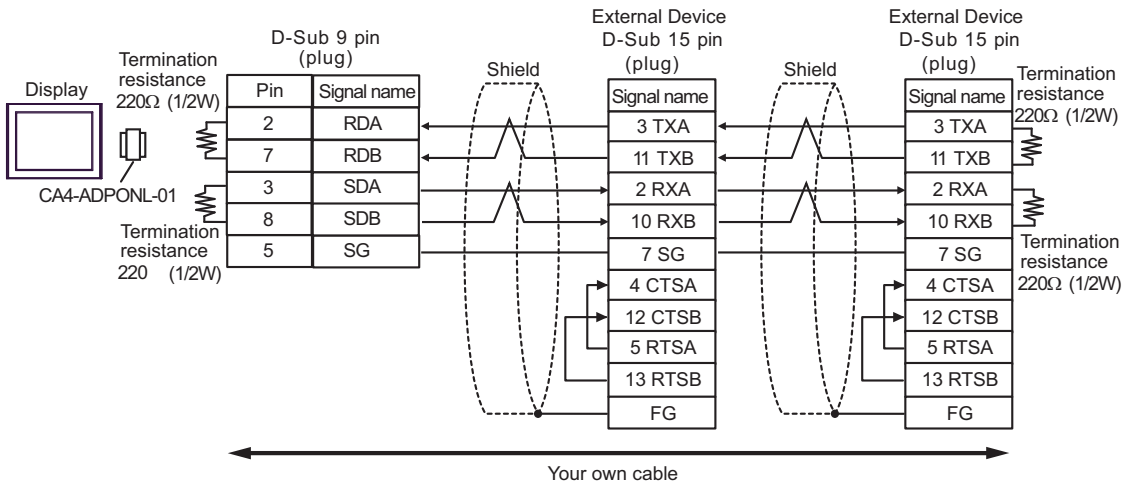

NOTE • We recommend CO-SPEV-SB(A)3P*0.5 by Hitachi Cable, Ltd. for the connection cable.

3E)

- 1:1 Connection

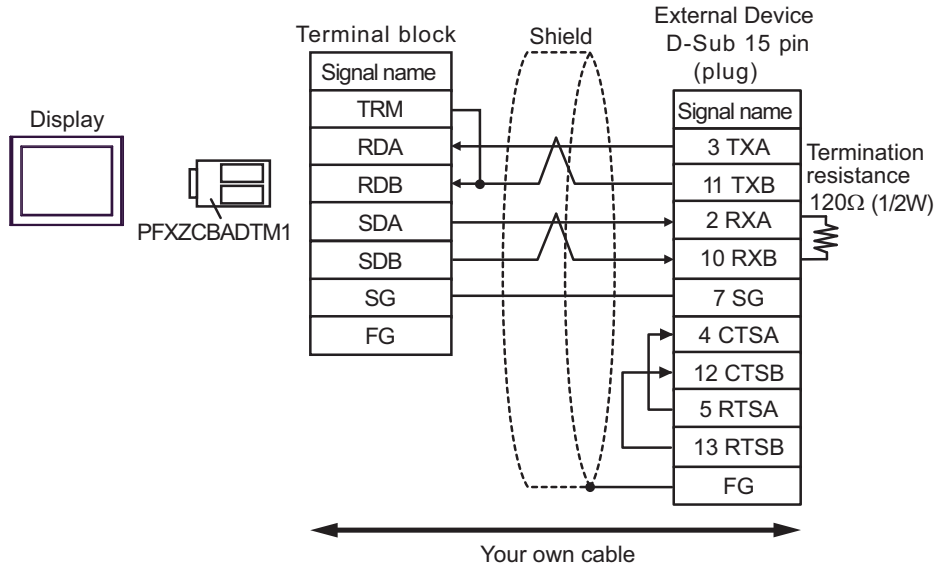

- 1:n Connection

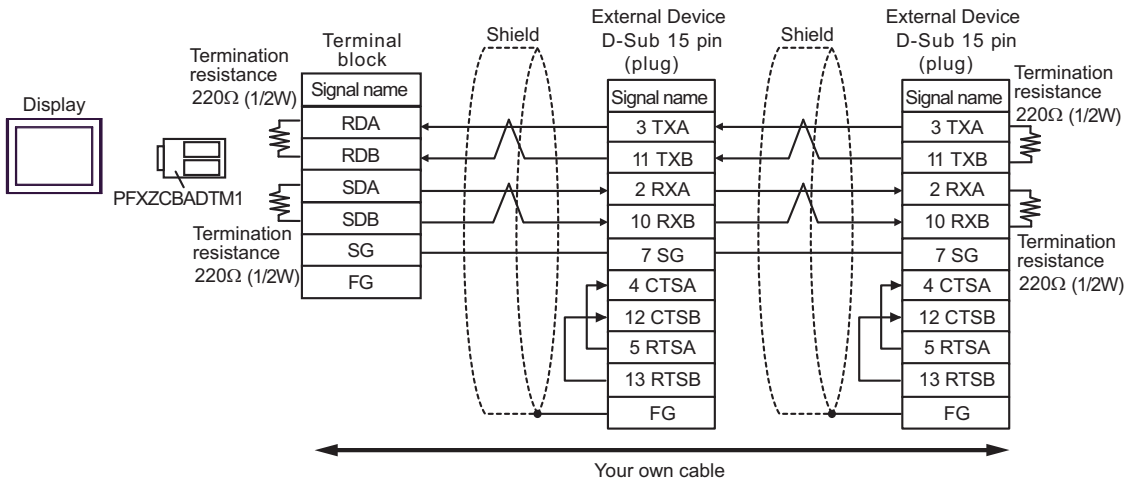

3F)

- 1:1 Connection

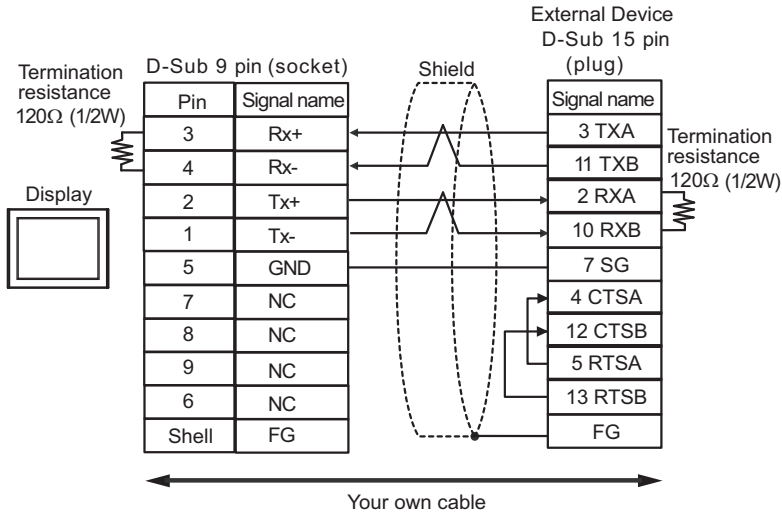

- 1:n Connection

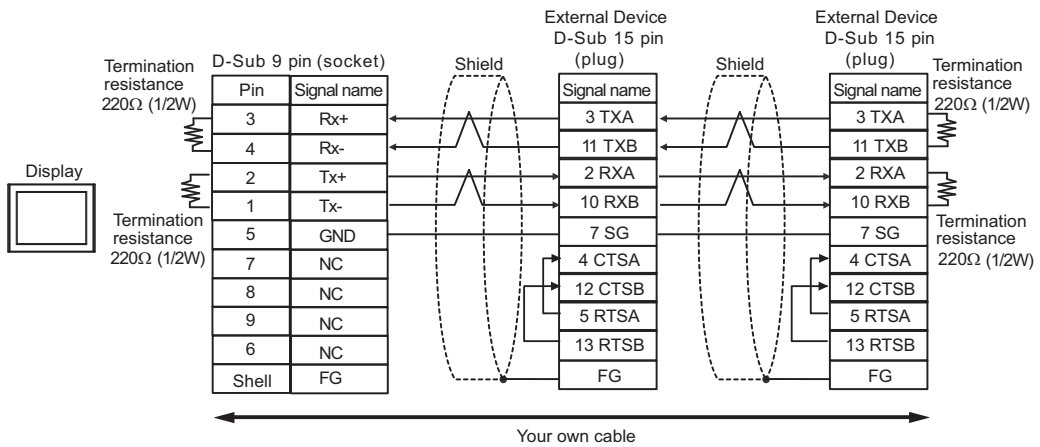

NOTE • We recommend CO-SPEV-SB(A)3P*0.5 by Hitachi Cable, Ltd. for the connection cable.

3G)

- 1:1 Connection

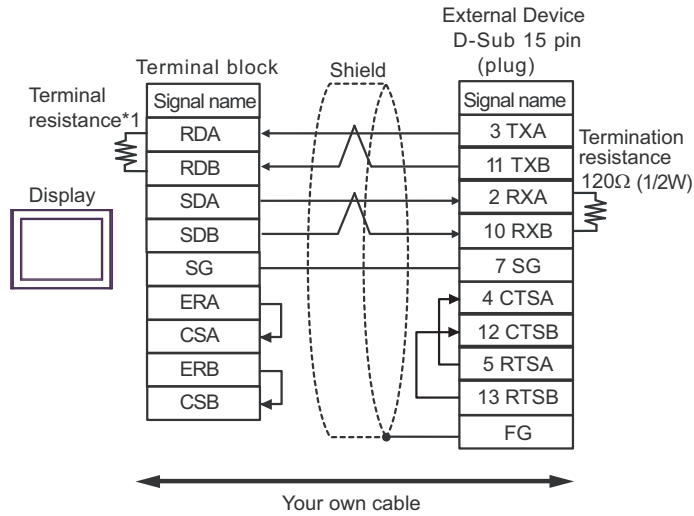

- *1 The resistance in the Display is used as the termination resistance. Set the value of the DIP Switch on the rear of the Display as shown in the table below.

DIP Switch No.	Set Value
1	OFF
2	OFF
3	ON
4	ON

- 1:n Connection

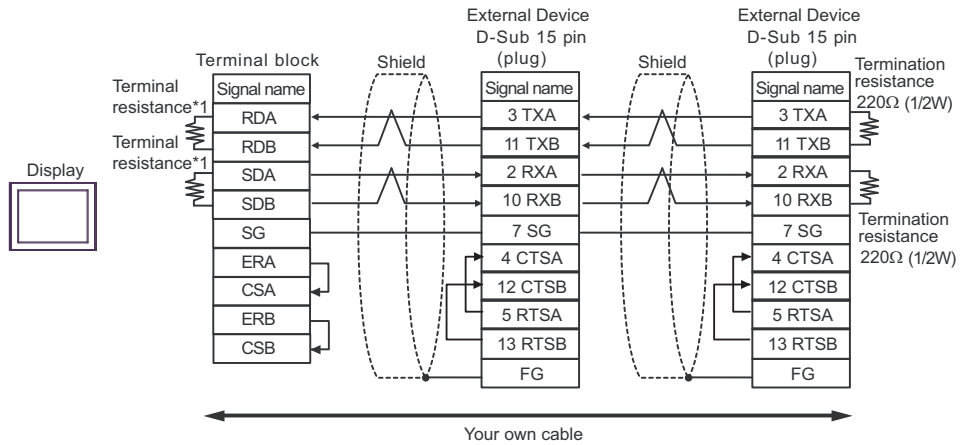
**NOTE**

- We recommend CO-SPEV-SB(A)3P*0.5 by Hitachi Cable, Ltd. for the connection cable.

- *1 The resistance in the Display is used as the termination resistance. Set the value of the DIP Switch on the rear of the Display as shown in the table below.

DIP Switch No.	Set Value
1	OFF
2	ON
3	OFF
4	ON

Cable Diagram 4

Display (Connection Port)	Cable		Remarks
GP3000* ¹ (COM1) AGP-3302B(COM2) GP-4*01TM (COM1) GP-Rear Module (COM1) ST3000* ² (COM2) LT3000 (COM1) IPC* ³	4A	COM port conversion adapter by Digital Electronics Corp. CA3-ADPCOM-01 + Connector terminal block conversion adapter by Digital Electronics Corp. CA3-ADPTRM-01 + Your own cable	Cable length: 1,000m or less
	4B	Your own cable	
	4C	COM port conversion adapter by Digital Electronics Corp. CA3-ADPCOM-01 + RS422 cable by Digital Electronics Corp. CA3-CBL422-01	
GP3000* ⁴ (COM2)	4D	Online adapter by Digital Electronics Corp. CA4-ADPONL-01 + Connector terminal block conversion adapter by Digital Electronics Corp. CA3-ADPTRM-01 + Your own cable	Cable length: 1,000m or less
	4E	Online adapter by Digital Electronics Corp. CA4-ADPONL-01 + Your own cable	
	4F	Online adapter by Digital Electronics Corp. CA4-ADPONL-01 + RS422 cable by Digital Electronics Corp. CA3-CBL422-01	
GP-4116T (COM1)	4I	Your own cable	Cable length: 1,000m or less
GP4000* ⁵ (COM2) GP-4201T (COM1) SP5000* ⁶ (COM1/2) SP-5B00 (COM2) ST6000* ⁷ (COM2) ST-6200 (COM1) STM6000 (COM1) STC6000 (COM1) ET6000* ⁸ (COM2) PS6000 (Basic Box) (COM1/2)	4G	RS-422 terminal block conversion adapter by Digital Electronics Corp. PFXZCBADTM1* ⁹ + Your own cable	Cable length: 1,000m or less
	4B	Your own cable	
	4C	COM port conversion adapter by Digital Electronics Corp. CA3-ADPCOM-01 + RS422 cable by Digital Electronics Corp. CA3-CBL422-01	

Display (Connection Port)	Cable		Remarks
PE-4000B ^{*10} PS5000 ^{*10} PS6000 (Optional Interface) ^{*10}	4H	Your own cable	Cable length: 1,000m or less

*1 All GP models except AGP-3302B

*2 Except AST-3211A and AST-3302B

*3 Available to use only the COM ports which can communicate in RS422/485(4 wire). (Except PE-4000B, PS5000, and PS6000)

☞ ■ IPC COM Port (page 5)

*4 All GP models except GP-3200 Series and AGP-3302B

*5 All GP4000 models except GP-4100 series, GP-4*01TM, GP-Rear Module, GP-4201T and GP-4*03T

*6 Except SP-5B00

*7 Except ST-6200

*8 Due to the COM port specifications, flow control is not possible. Omit wiring the control pins on the Display side of the cable diagram.

*9 When using a Terminal Block Conversion Adapter (CA3-ADPTRM-01) instead of the RS-422 Terminal Block Conversion Adapter, refer to Cable Diagram 4A.

*10 Available to use only the COM ports which can communicate in RS422/485(4 wire).

☞ ■ IPC COM Port (page 5)

4A)

- 1:1 Connection

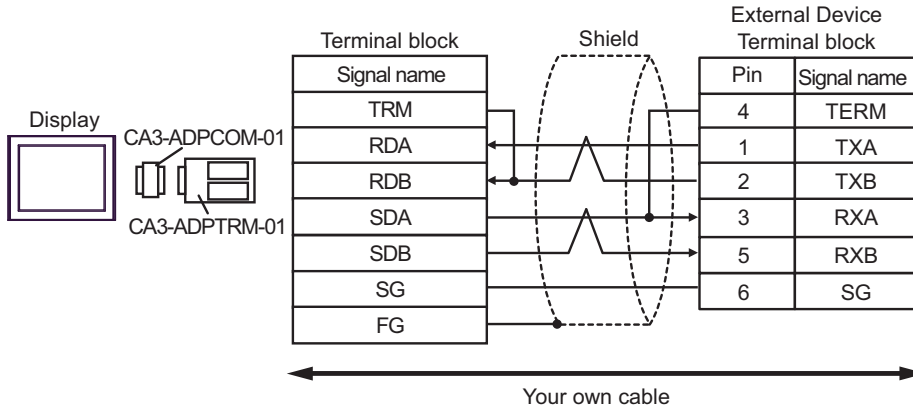

- 1:n Connection

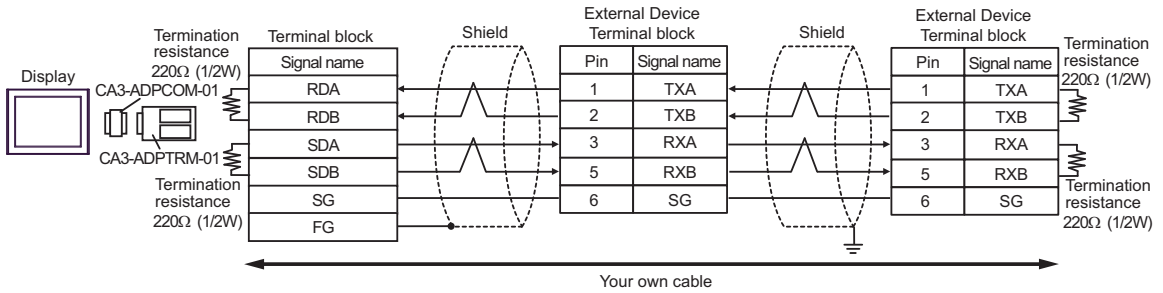

NOTE • When IPC is used as the Display, the terminal resistance of 220Ω can be inserted by the fact that the dip switch 5, 6 of IPC is turned to ON.

4B)

- 1:1 Connection

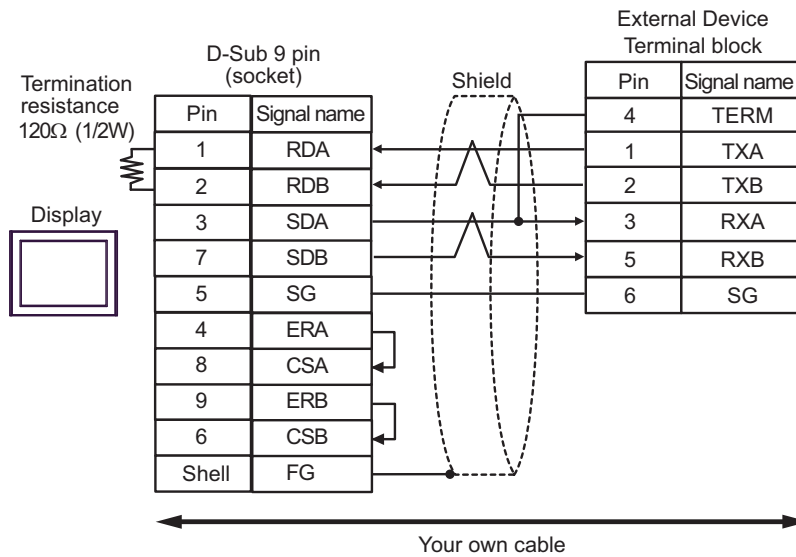

- 1:n Connection

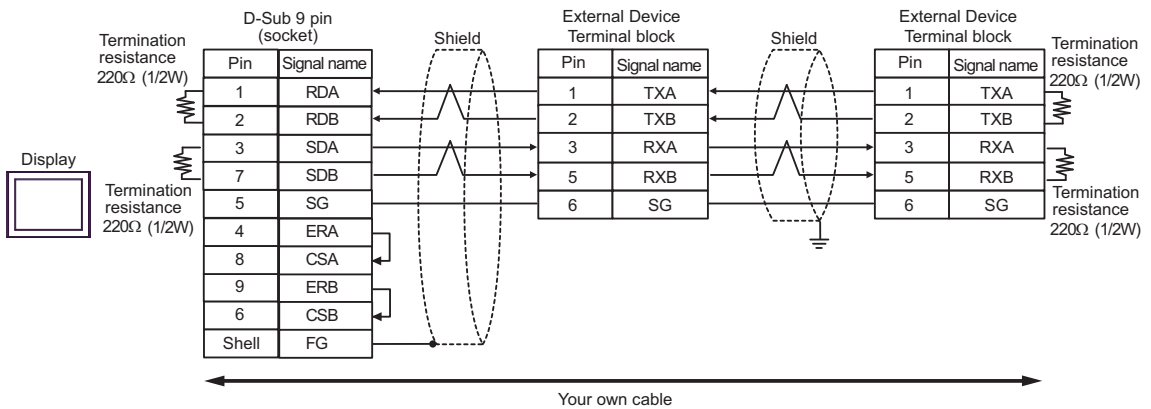
**NOTE**

- We recommend CO-SPEV-SB(A)3P*0.5 by Hitachi Cable, Ltd. for the connection cable.
- When IPC is used as the Display, the terminal resistance of 220Ω can be inserted by the fact that the dip switch 5, 6 of IPC is turned to ON.

4C)

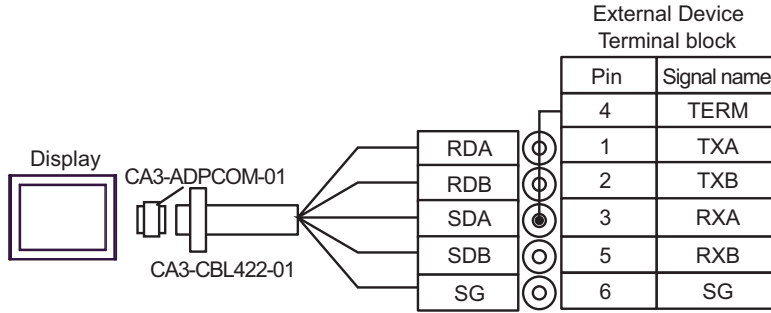

- NOTE**
- When using the CA3-CBL422-01 cable, connect nothing to FG.
 - Available only in the EX Series due to the different connector type.

4D)

- 1:1 Connection

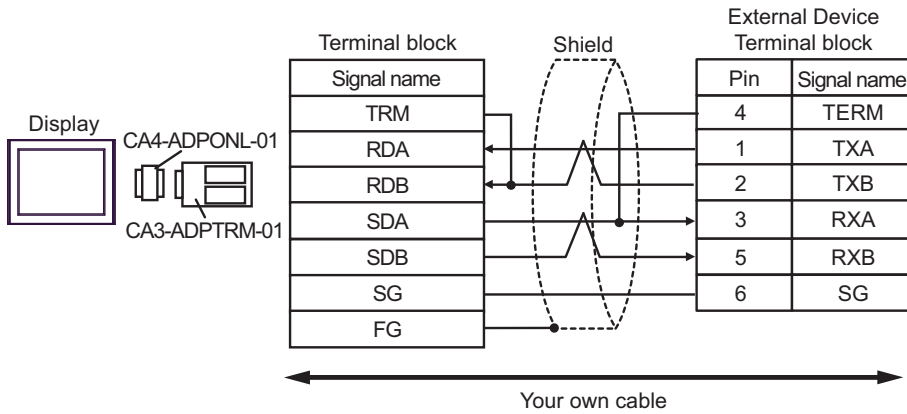

- 1:n Connection

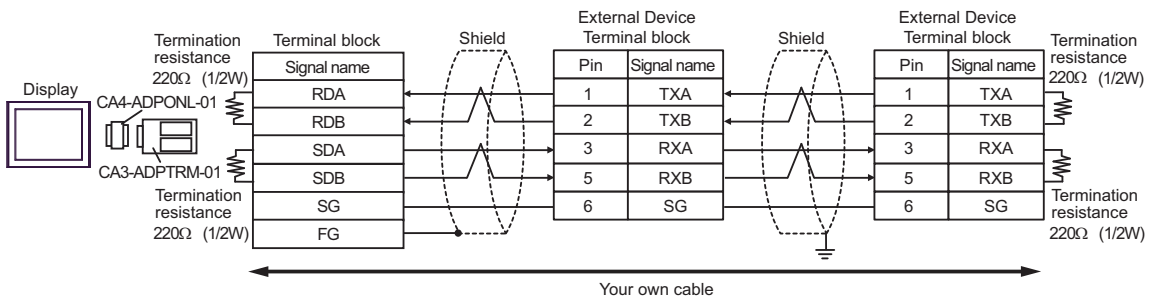

4E)

- 1:1 Connection

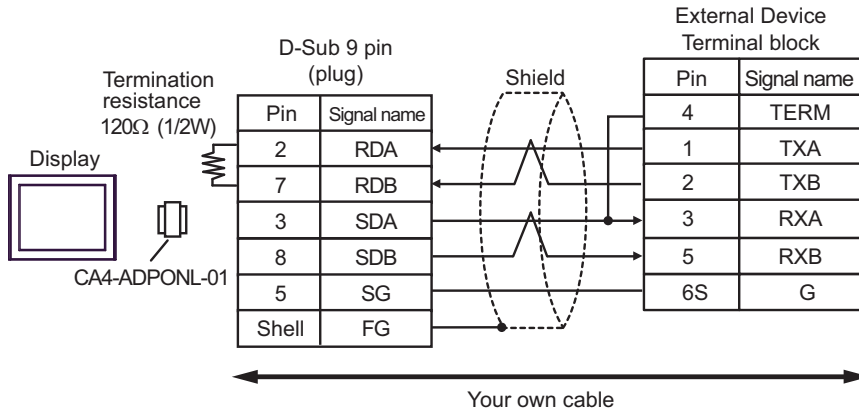

- 1:n Connection

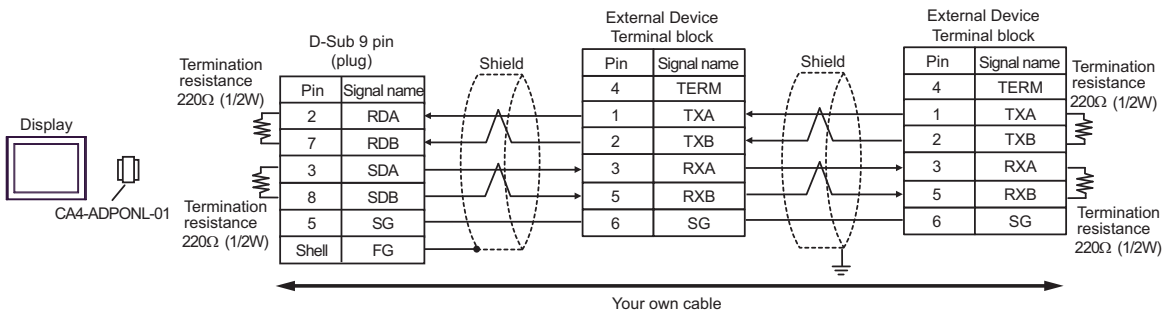

NOTE

- We recommend CO-SPEV-SB(A)3P*0.5 by Hitachi Cable, Ltd. for the connection cable.

4F)

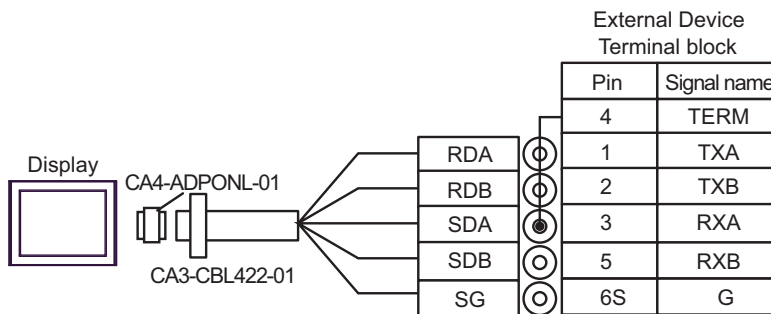

NOTE

- When using the CA3-CBL422-01 cable, connect nothing to FG.
- Available only in the EX Series due to the different connector type.

4G)

- 1:1 Connection

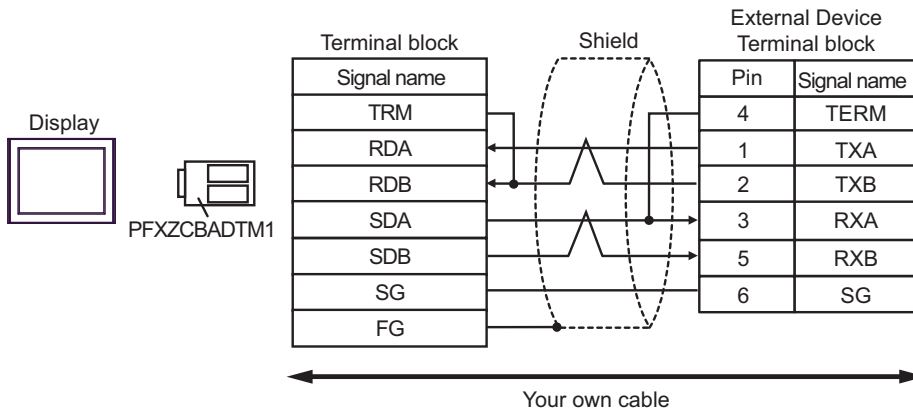

- 1:n Connection

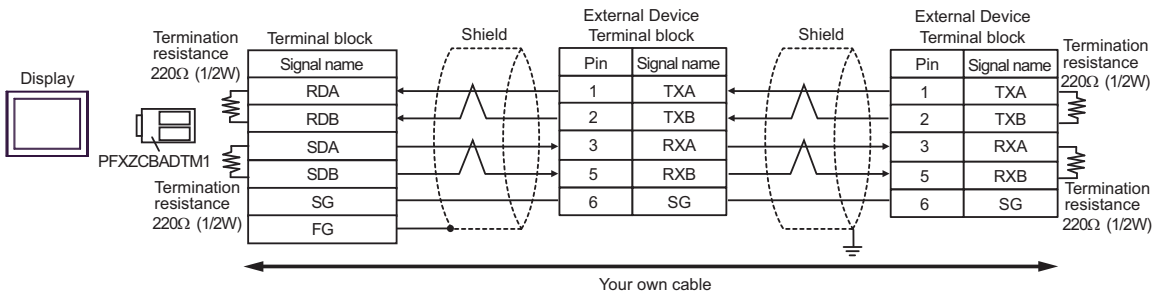

4H)

- 1:1 Connection

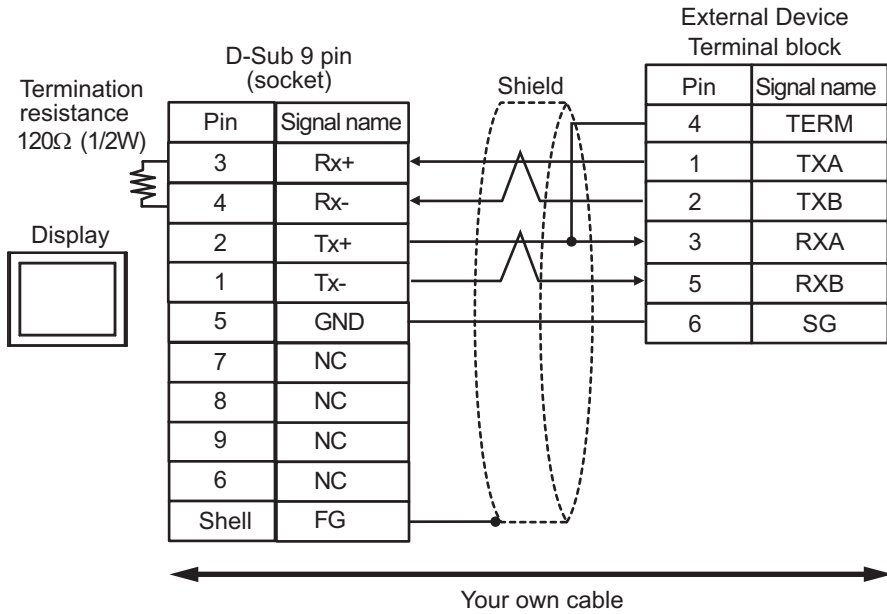

- 1:n Connection

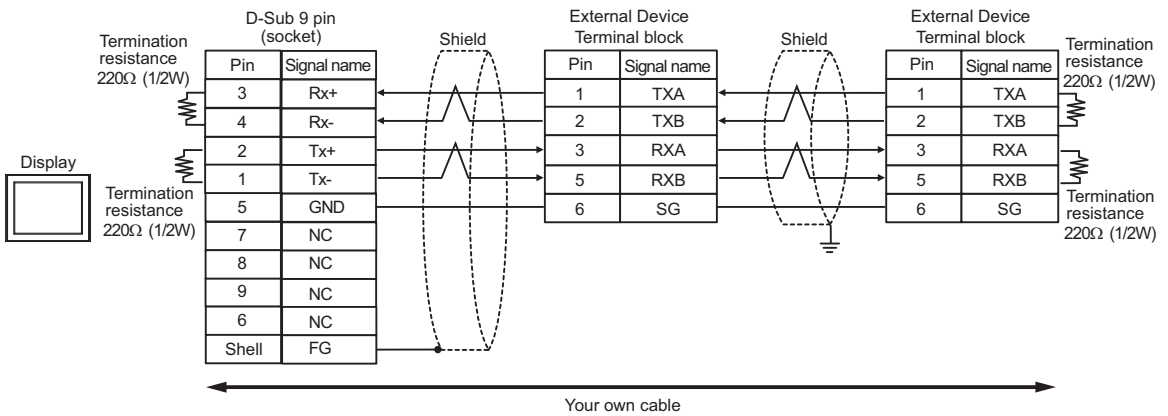

NOTE

- We recommend CO-SPEV-SB(A)3P*0.5 by Hitachi Cable, Ltd. for the connection cable.

4l)

- 1:1 Connection

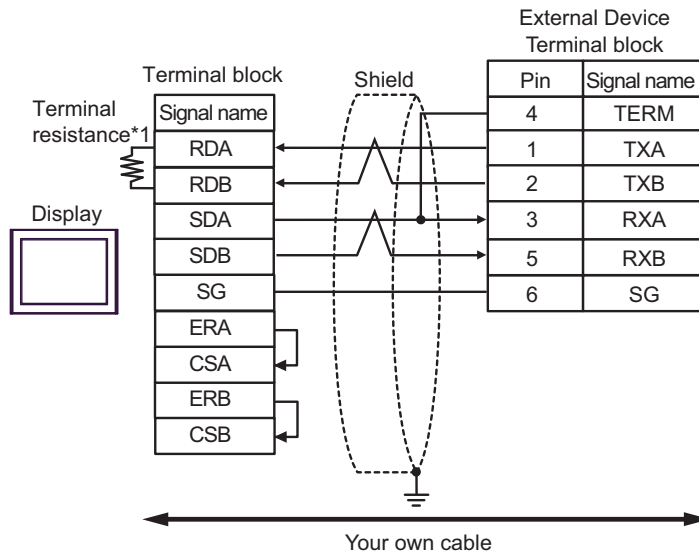

- *1 The resistance in the Display is used as the termination resistance. Set the value of the DIP Switch on the rear of the Display as shown in the table below.

DIP Switch No.	Set Value
1	OFF
2	OFF
3	ON
4	ON

• 1:n Connection

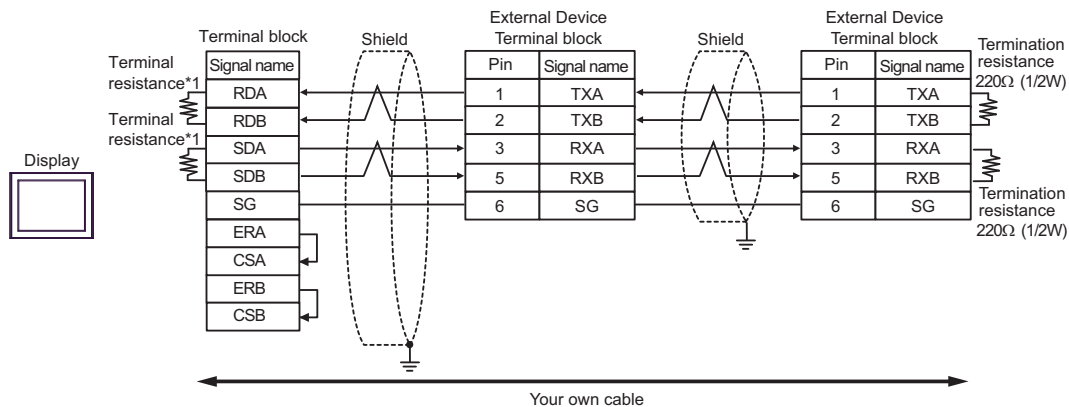

NOTE • We recommend CO-SPEV-SB(A)3P*0.5 by Hitachi Cable, Ltd. for the connection cable.

*1 The resistance in the Display is used as the termination resistance. Set the value of the DIP Switch on the rear of the Display as shown in the table below.

DIP Switch No.	Set Value
1	OFF
2	ON
3	OFF
4	ON

Cable Diagram 5

Display (Connection Port)	Cable		Remarks
GP3000* ¹ (COM1) AGP-3302B(COM2) GP-4*01TM (COM1) GP-Rear Module (COM1) ST3000* ² (COM2) LT3000 (COM1) IPC* ³	5A	COM port conversion adapter by Digital Electronics Corp. CA3-ADPCOM-01 + Connector terminal block conversion adapter by Digital Electronics Corp. CA3-ADPTRM-01 + Your own cable	Cable length: 1,000m or less
	5B	Your own cable	
GP3000* ⁴ (COM2)	5C	Online adapter by Digital Electronics Corp. CA4-ADPONL-01 + Connector terminal block conversion adapter by Digital Electronics Corp. CA3-ADPTRM-01 + Your own cable	Cable length: 1,000m or less
	5D	Online adapter by Digital Electronics Corp. CA4-ADPONL-01 + Your own cable	
GP-4116T (COM1)	5G	Your own cable	Cable length: 1,000m or less
GP4000* ⁵ (COM2) GP-4201T (COM1) SP5000* ⁶ (COM1/2) SP-5B00 (COM2) ST6000* ⁷ (COM2) ST-6200 (COM1) STM6000 (COM1) STC6000 (COM1) ET6000* ⁸ (COM2) PS6000 (Basic Box) (COM1/2)	5E	RS-422 terminal block conversion adapter by Digital Electronics Corp. PFXZCBADTM1* ⁹ + Your own cable	Cable length: 1,000m or less
	5B	Your own cable	
PE-4000B* ¹⁰ PS5000* ¹⁰ PS6000 (Optional Interface)* ¹⁰	5F	Your own cable	Cable length: 1,000m or less

*1 All GP models except AGP-3302B

*2 Except AST-3211A and AST-3302B

*3 Available to use only the COM ports which can communicate in RS422/485(4 wire). (Except PE-4000B, PS5000, and PS6000)

 ■ IPC COM Port (page 5)

*4 All GP models except GP-3200 Series and AGP-3302B

*5 All GP4000 models except GP-4100 series, GP-4*01TM, GP-Rear Module, GP-4201T and GP-4*03T

*6 Except SP-5B00

*7 Except ST-6200

- *8 Due to the COM port specifications, flow control is not possible. Omit wiring the control pins on the Display side of the cable diagram.
- *9 When using a Terminal Block Conversion Adapter (CA3-ADPTRM-01) instead of the RS-422 Terminal Block Conversion Adapter, refer to Cable Diagram 5A.
- *10 Available to use only the COM ports which can communicate in RS422/485(4 wire).
 ■ IPC COM Port (page 5)

5A)

- 1:1 Connection

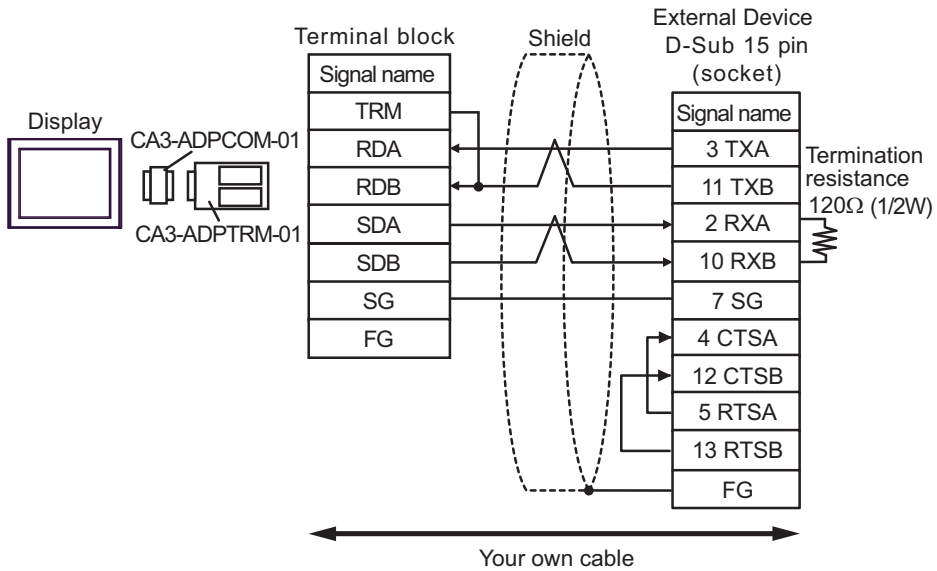

- 1:n Connection

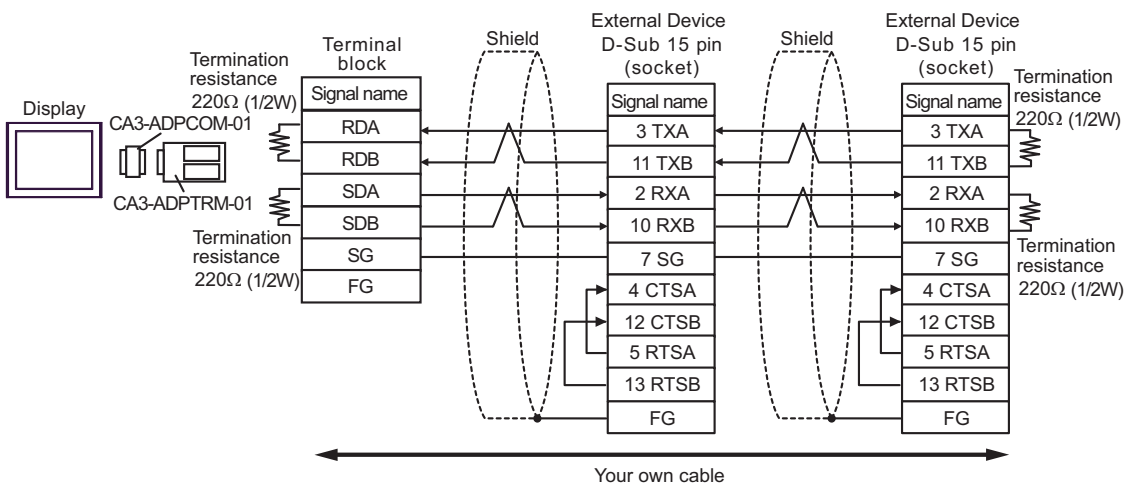

NOTE

- When IPC is used as the Display, the terminal resistance of 220Ω can be inserted by the fact that the dip switch 5, 6 of IPC is turned to ON.

5B)

- 1:1 Connection

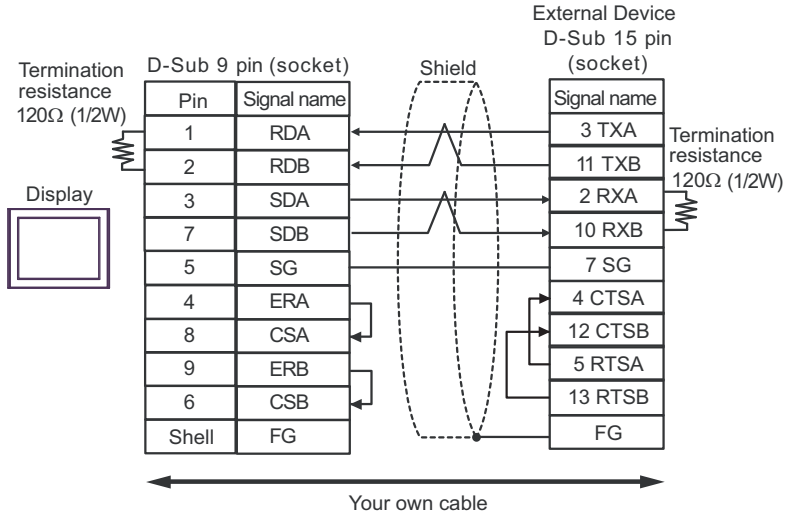

- 1:n Connection

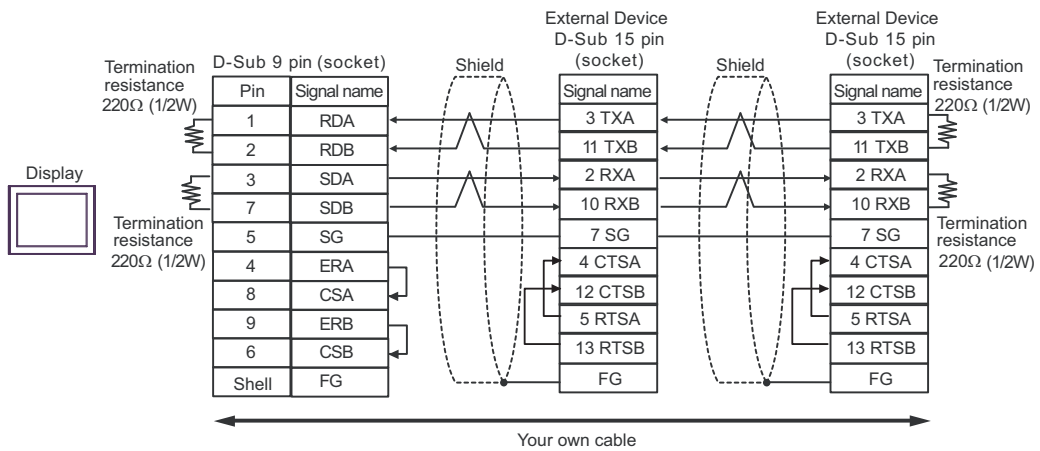

NOTE

- We recommend CO-SPEV-SB(A)3P*0.5 by Hitachi Cable, Ltd. for the connection cable.
- When IPC is used as the Display, the terminal resistance of 220Ω can be inserted by the fact that the dip switch 5, 6 of IPC is turned to ON.

5C)

- 1:1 Connection

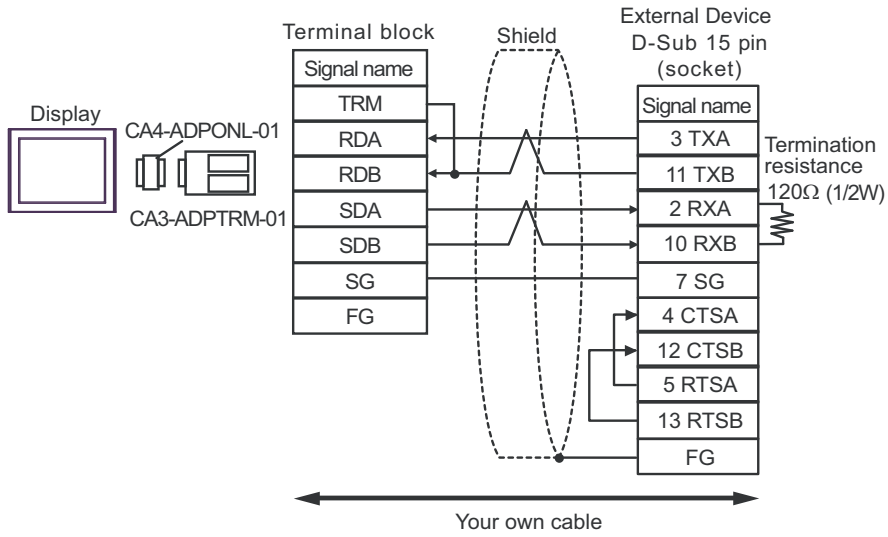

- 1:n Connection

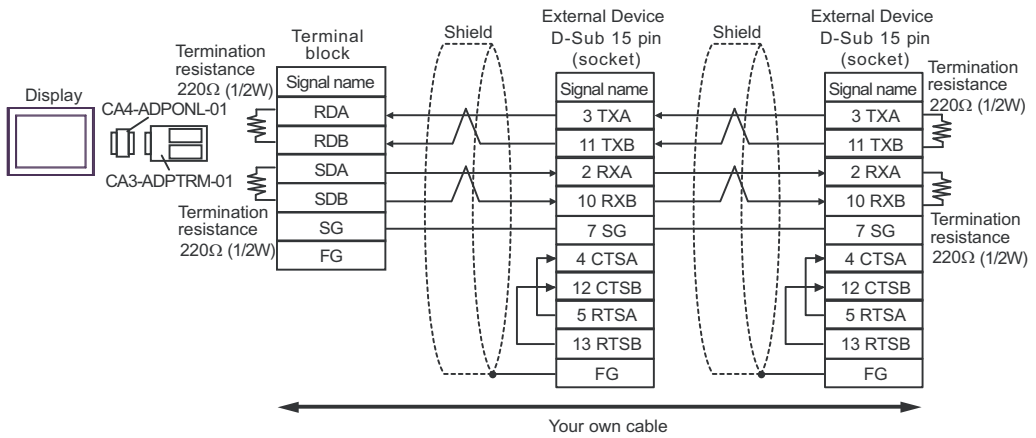

5D)

- 1:1 Connection

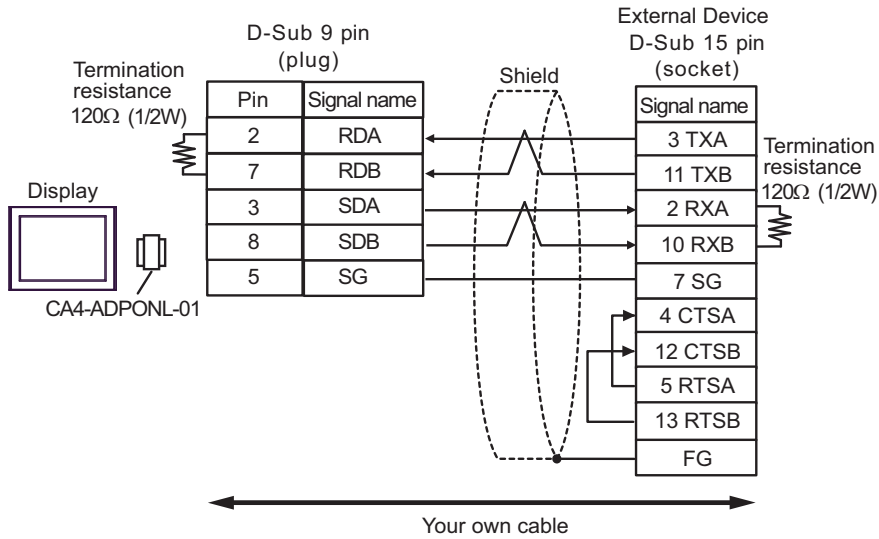

- 1:n Connection

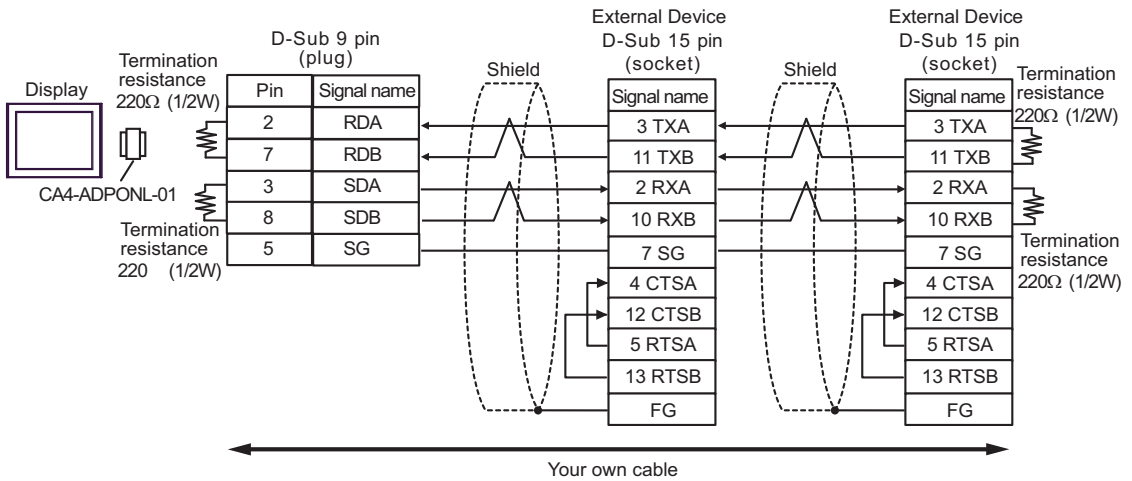

NOTE

- We recommend CO-SPEV-SB(A)3P*0.5 by Hitachi Cable, Ltd. for the connection cable.

5E)

- 1:1 Connection

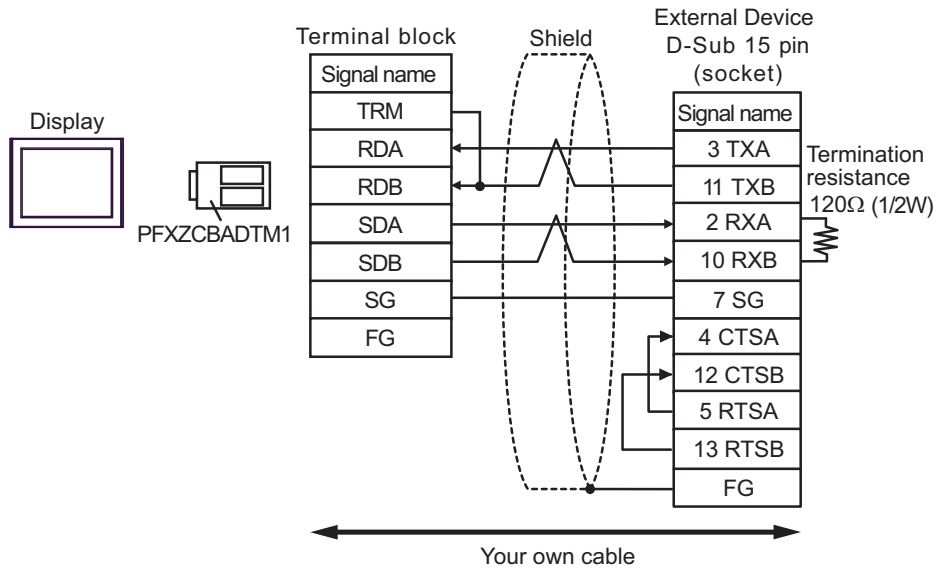

- 1:n Connection

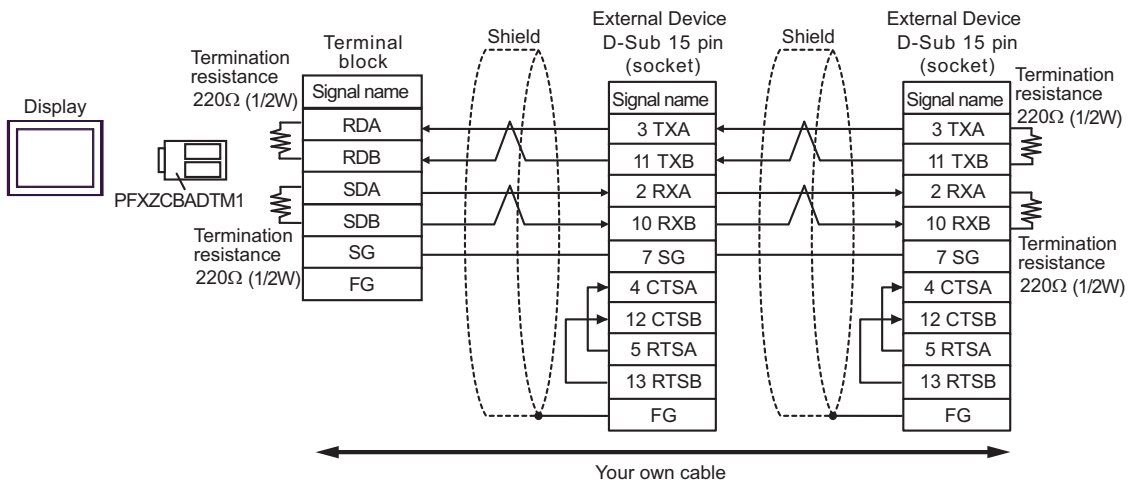

5F)

- 1:1 Connection

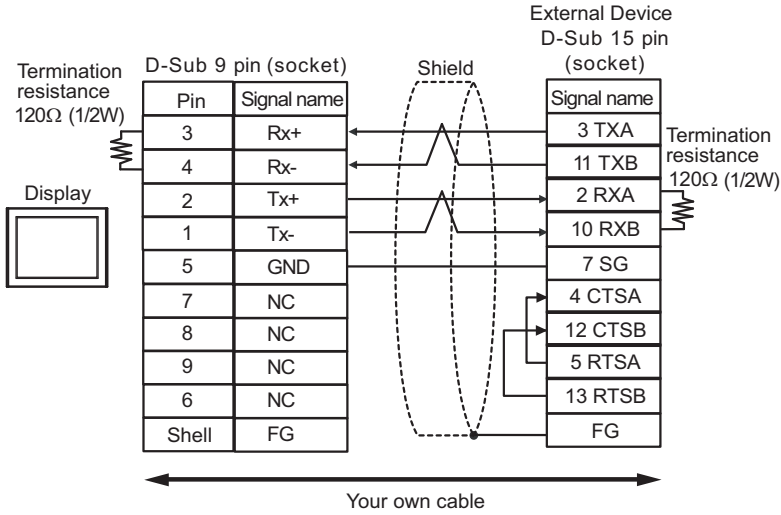

- 1:n Connection

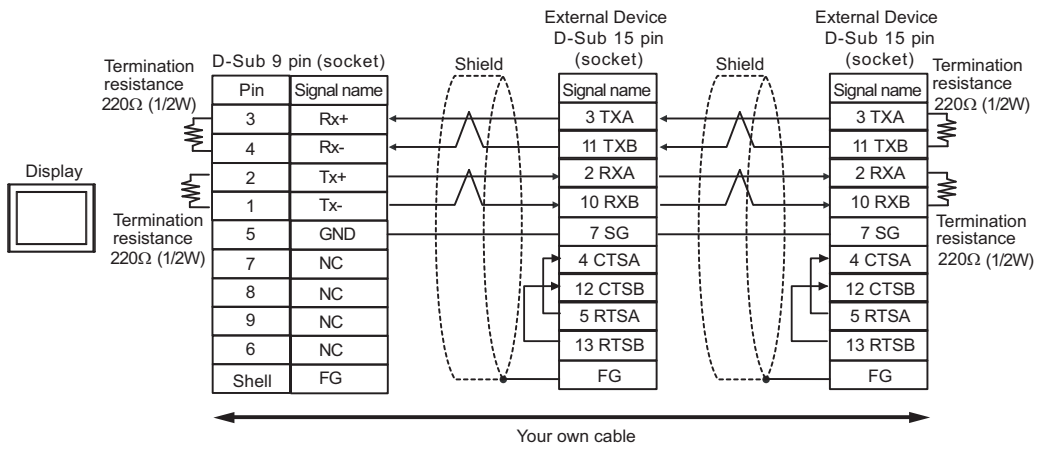

NOTE • We recommend CO-SPEV-SB(A)3P*0.5 by Hitachi Cable, Ltd. for the connection cable.

5G)

- 1:1 Connection

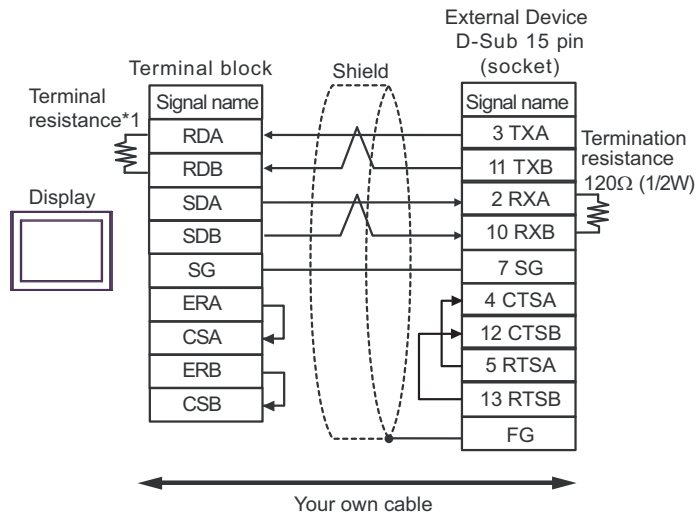

- *1 The resistance in the Display is used as the termination resistance. Set the value of the DIP Switch on the rear of the Display as shown in the table below.

DIP Switch No.	Set Value
1	OFF
2	OFF
3	ON
4	ON

- 1:n Connection

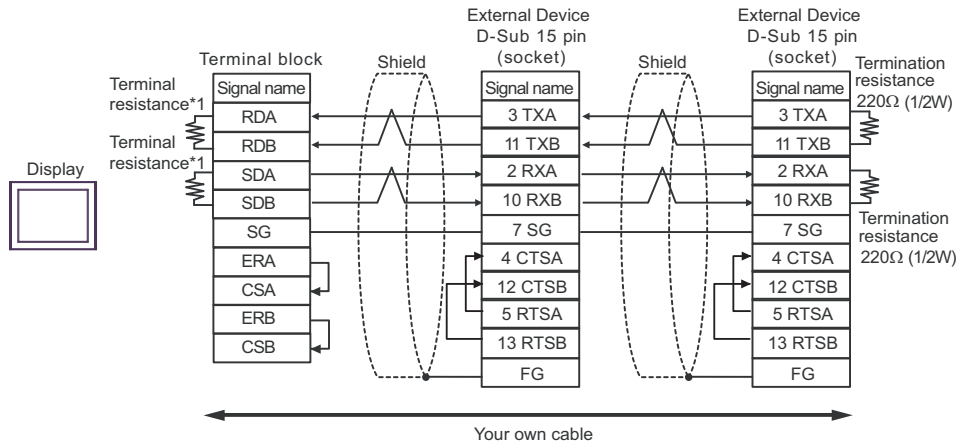
**NOTE**

- We recommend CO-SPEV-SB(A)3P*0.5 by Hitachi Cable, Ltd. for the connection cable.

- *1 The resistance in the Display is used as the termination resistance. Set the value of the DIP Switch on the rear of the Display as shown in the table below.

DIP Switch No.	Set Value
1	OFF
2	ON
3	OFF
4	ON





6 Supported Device

Range of supported device address is shown in the table below. Available type and range of device vary depending on CPU. Be sure to check them in each CPU manual before using.

6.1 T Series

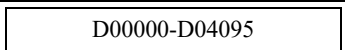
■ T2E

 : This address can be specified as system data area.

Device	Bit Address	Word Address	32 bits	Remarks
Input	X00000-X0063F	XW0000-XW0063		
Output	Y00000-Y0063F	YW0000-YW0063		
Auxiliary Relay	R00000-R0127F	RW0000-RW0127		
Special Relay	S00000-S0255F	SW0000-SW0255		
Timer Register	-	T0000-T0255		
Timer Device	T.0000-T.0255	-		*1
Counter Register	-	C0000-C0255		
Counter Device	C.0000-C.0255	-		*1
Link Relay	L00000-L0255F	LW0000-LW0255		
Link Register Relay	Z00000-Z0511F	-		
Data Register	-	 D00000-D04095		
Link Register	-	W00000-W01023		
File Register	-	F00000-F01023		

*1 Write disable

NOTE

- Please refer to the GP-Pro EX Reference Manual for system data area.
Cf. GP-Pro EX Reference Manual "LS Area (Direct Access Method Area)"
- Please refer to the precautions on manual notation for icons in the table.
 "Manual Symbols and Terminology"

■ T2N

 : This address can be specified as system data area.

Device	Bit Address	Word Address	32 bits	Remarks
Input	X00000-X0127F	XW0000-XW0127	L/H	
Output	Y00000-Y0127F	YW0000-YW0127		
Auxiliary Relay	R00000-R0255F	RW0000-RW0255		
Special Relay	S00000-S0255F	SW0000-SW0255		
Link Relay	L00000-L0255F	LW0000-LW0255		
Timer Register	-	T0000-T0511		
Timer Device	T.0000-T.0511	-		*1
Counter Register	-	C0000-C0511		
Counter Device	C.0000-C.0511	-		*1
Link Register Relay	Z00000-Z0999F	-		
Data Register	-	D00000-D08191		Bit F
Link Register	-	W00000-W02047		Bit F
File Register	-	F00000-F01023		Bit F

*1 Write disable

NOTE

- Please refer to the GP-Pro EX Reference Manual for system data area.
Cf. GP-Pro EX Reference Manual "LS Area (Direct Access Method Area)"
- Please refer to the precautions on manual notation for icons in the table.
 "Manual Symbols and Terminology"

■ T3

 : This address can be specified as system data area.

Device	Bit Address	Word Address	32 bits	Remarks
Input	X00000-X0255F	XW0000-XW0255	L/H	
Output	Y00000-Y0255F	YW0000-YW0255		
Auxiliary Relay	R00000-R0511F	RW0000-RW0511		
Special Relay	S00000-S0255F	SW0000-SW0255		
Link Relay	L00000-L0255F	LW0000-LW0255		
Timer Register	-	T0000-T0511		
Timer Device	T.0000-T.0511	-		*1
Counter Register	-	C0000-C0511		
Counter Device	C.0000-C.0511	-		*1
Link Register Relay	Z00000-Z0511F	-		
Data Register	-	D00000-D08191		Bit F
Link Register	-	W00000-W01023		Bit F
File Register	-	F00000-F08191		Bit F

*1 Write disable

NOTE

- Please refer to the GP-Pro EX Reference Manual for system data area.
Cf. GP-Pro EX Reference Manual "LS Area (Direct Access Method Area)"
- Please refer to the precautions on manual notation for icons in the table.
 "Manual Symbols and Terminology"

■ T3H/S2T/S2E

 : This address can be specified as system data area.

Device	Bit Address	Word Address	32 bits	Remarks
Input	X00000-X0511F	XW0000-XW0511	L/H	
Output	Y00000-Y0511F	YW0000-YW0511		
Auxiliary Relay	R00000-R0999F	RW0000-RW0999		
Special Relay	S00000-S0255F	SW0000-SW0255		
Link Relay	L00000-L0255F	LW0000-LW0255		
Timer Register	-	T0000-T0999		
Timer Device	T.0000-T.0999	-		*1
Counter Register	-	C0000-C0511		
Counter Device	C.0000-C.0511	-		*1
Link Register Relay	Z00000-Z0999F	-		
Data Register	-	D00000-D08191		Bit F
Link Register	-	W00000-W02047		Bit F
File Register	-	F00000-F32767		Bit F

*1 Write disable



NOTE

- Please refer to the GP-Pro EX Reference Manual for system data area.
Cf. GP-Pro EX Reference Manual "LS Area (Direct Access Method Area)"
- Please refer to the precautions on manual notation for icons in the table.
 "Manual Symbols and Terminology"

6.2 V Series

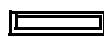
■ Model2000(S2PU22/S2PU32/S2PU72/S2PU82)

 : This address can be specified as system data area.

Device	Bit Address	Word Address	32 bits	Remarks
I Variable	IX00000-IX3071F	IW0000-IW3071		
O Variable	QX00000-QX3071F	QW0000-QW3071		
System	S00000-S0511F	SW0000-SW0511		
Data	-	DW0000-DW4095		 *1
Data	R00000-R4095F	RW0000-RW4095		*1
User Register	-	F00000-F32767		

*1 R, RW device and D device use the same area. Designate the R device when doing bit write from the Display.

NOTE

- Although local variables, control global variables and station global variables exist outside of the above-mentioned device, they are not accessible from the Display.
- Please refer to the GP-Pro EX Reference Manual for system data area.



Cf. GP-Pro EX Reference Manual "LS Area (Direct Access Method Area)"

- Please refer to the precautions on manual notation for icons in the table.

 "Manual Symbols and Terminology"

■ Model3000(S3PU21)

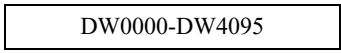
 : This address can be specified as system data area.

Device	Bit Address	Word Address	32 bits	Remarks
I Variable	IX00000-IX3071F	IW0000-IW3071		
O Variable	QX00000-QX3071F	QW0000-QW3071		
System	S00000-S0511F	SW0000-SW0511		
Data	-	 DW0000-DW4095		 *1
Data	R00000-R4095F	RW0000-RW4095		*1
User Register	-	F00000-F32767		

*1 R, RW device and D device use the same area. Designate the R device when doing bit write from the Display.

NOTE

- Although local variables, control global variables and station global variables exist outside of the above-mentioned device, they are not accessible from the Display.
- Please refer to the GP-Pro EX Reference Manual for system data area.



Cf. GP-Pro EX Reference Manual "LS Area (Direct Access Method Area)"

- Please refer to the precautions on manual notation for icons in the table.

 "Manual Symbols and Terminology"

■ Model3000(S3PU45)

 : This address can be specified as system data area.

Device	Bit Address	Word Address	32 bits	Remarks
I Variable	IX00000-IX5119F	IW0000-IW5119		
O Variable	QX00000-QX5119F	QW0000-QW5119		
System	S00000-S0511F	SW0000-SW0511		
Data	-	DW0000-DW4095		 *1
Data	R00000-R4095F	RW0000-RW4095		*1
User Register	-	F00000-F32767		

*1 R, RW device and D device use the same area. Designate the R device when doing bit write from the Display.

NOTE

- Although local variables, control global variables and station global variables exist outside of the above-mentioned device, they are not accessible from the Display.
- Please refer to the GP-Pro EX Reference Manual for system data area.



Cf. GP-Pro EX Reference Manual "LS Area (Direct Access Method Area)"

- Please refer to the precautions on manual notation for icons in the table.

 "Manual Symbols and Terminology"

■ Model3000(S3PU55/S3PU65)

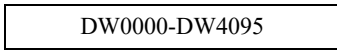
 : This address can be specified as system data area.

Device	Bit Address	Word Address	32 bits	Remarks
I Variable	IX00000-IX8191F	IW0000-IW8191		
O Variable	QX00000-QX8191F	QW0000-QW8191		
System	S00000-S0511F	SW0000-SW0511		
Data	-	 DW0000-DW4095		 *1
Data	R00000-R4095F	RW0000-RW4095		*1
User Register	-	F00000-F32767		

*1 R, RW device and D device use the same area. Designate the R device when doing bit write from the Display.

NOTE

- Although local variables, control global variables and station global variables exist outside of the above-mentioned device, they are not accessible from the Display.
- Please refer to the GP-Pro EX Reference Manual for system data area.

Cf. GP-Pro EX Reference Manual "LS Area (Direct Access Method Area)"



- Please refer to the precautions on manual notation for icons in the table.

 "Manual Symbols and Terminology"

6.3 EX Series

■ EX2000

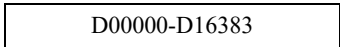
 : This address can be specified as system data area.

Device	Bit Address	Word Address	32 bits	Remarks
External Input	X00000-X0499F	XW0000-XW0499		
External Output	Y00000-Y0499F	YW0000-YW0499		
Auxiliary Relay	R00000-R0999F	RW0000-RW0999		
Link Relay	Z00000-Z0999F	ZW0000-ZW1999		
Timer Device	T.0000-T.0499	-		*1
Counter Device	C.0000-C.0499	-		*1
Data Register	-	 D00000-D16383		
Timer Register	-	T00000-T00499		
Counter Register	-	C00000-C00499		

*1 Write disable

NOTE

- Please refer to the GP-Pro EX Reference Manual for system data area.
Cf. GP-Pro EX Reference Manual "LS Area (Direct Access Method Area)"
- Please refer to the precautions on manual notation for icons in the table.
 "Manual Symbols and Terminology"

7 Device Code and Address Code

Use device code and address code when you select "Device Type & Address" for the address type in data displays.

7.1 T Series

■ T2E

Device	Device Name	Device Code (HEX)	Address Code
Input Register	XW	0080	Word Address
Input Device	X		Word Address
Output Register	YW	0081	Word Address
Output Device	Y		Word Address
Auxiliary Register	RW	0084	Word Address
Auxiliary Relay	R		Word Address
Special Register	SW	0085	Word Address
Special Relay	S		Word Address
Timer Register	T	0060	Word Address
Counter Register	C	0061	Word Address
Data Register	D	0000	Word Address
Link Register	W	0001	Word Address
Link Relay Register	LW	0086	Word Address
Link Relay Device	L		Word Address
File Register	F	0002	Word Address

■ T2N

Device	Device Name	Device Code (HEX)	Address Code
Input Register	XW	0080	Word Address
Input Device	X		Word Address
Output Register	YW	0081	Word Address
Output Device	Y		Word Address
Auxiliary Register	RW	0084	Word Address
Auxiliary Relay	R		Word Address
Special Register	SW	0085	Word Address
Special Relay	S		Word Address
Timer Register	T	0060	Word Address
Counter Register	C	0061	Word Address
Data Register	D	0000	Word Address
Link Register	W	0001	Word Address
Link Relay Register	LW	0086	Word Address
Link Relay Device	L		Word Address
File Register	F	0002	Word Address

■ T3

Device	Device Name	Device Code (HEX)	Address Code
Input Register	XW	0080	Word Address
Input Device	X		Word Address
Output Register	YW	0081	Word Address
Output Device	Y		Word Address
Auxiliary Register	RW	0084	Word Address
Auxiliary Relay	R		Word Address
Special Register	SW	0085	Word Address
Special Relay	S		Word Address
Timer Register	T	0060	Word Address
Counter Register	C	0061	Word Address
Data Register	D	0000	Word Address
Link Register	W	0001	Word Address
Link Relay Register	LW	0086	Word Address
Link Relay Device	L		Word Address
File Register	F	0002	Word Address

■ T3H/S2TS2E

Device	Device Name	Device Code (HEX)	Address Code
Input Register	XW	0080	Word Address
Input Device	X		Word Address
Output Register	YW	0081	Word Address
Output Device	Y		Word Address
Auxiliary Register	RW	0084	Word Address
Auxiliary Relay	R		Word Address
Special Register	SW	0085	Word Address
Special Relay	S		Word Address
Timer Register	T	0060	Word Address
Counter Register	C	0061	Word Address
Data Register	D	0000	Word Address
Link Register	W	0001	Word Address
Link Relay Register	LW	0086	Word Address
Link Relay Device	L		Word Address
File Register	F	0002	Word Address

7.2 V Series

■ Model2000(S2PU82)

Device	Device Name	Device Code (HEX)	Address Code
I Variable Register	IW	0080	Word Address
I Variable Device	IX		Word Address
O Variable Register	QW	0081	Word Address
O Variable Device	QX		Word Address
System Register	SW	0085	Word Address
System Device	S		Word Address
Data Register	DW	0000	Word Address
User Register	F	0002	Word Address
Data Register	RW	0084	Word Address
Data Device	R		Word Address

■ Model2000(S2PU22/S2PU32/S2PU72)

Device	Device Name	Device Code (HEX)	Address Code
I Variable Register	IW	0080	Word Address
I Variable Device	IX		Word Address
O Variable Register	QW	0081	Word Address
O Variable Device	QX		Word Address
System Register	SW	0085	Word Address
System Device	S		Word Address
Data	DW	0000	Word Address
Data Register	RW	0084	Word Address
Data Device	R		Word Address

■ Model3000(S3PU45)

Device	Device Name	Device Code (HEX)	Address Code
I Variable Register	IW	0080	Word Address
I Variable Device	IX		Word Address
O Variable Register	QW	0081	Word Address
O Variable Device	QX		Word Address
System Register	SW	0085	Word Address
System Device	S		Word Address
Data Register	DW	0000	Word Address
User Register	F	0002	Word Address
Data Register	RW	0084	Word Address
Data Device	R		Word Address

■ Model3000(S3PU55/S3PU65)

Device	Device Name	Device Code (HEX)	Address Code
I Variable Register	IW	0080	Word Address
I Variable Device	IX		Word Address
O Variable Register	QW	0081	Word Address
O Variable Device	QX		Word Address
System Register	SW	0085	Word Address
System Device	S		Word Address
Data Register	DW	0000	Word Address
User Register	F	0002	Word Address
Data Register	RW	0084	Word Address
Data Device	R		Word Address

7.3 EX Series

Device	Device Name	Device Code (HEX)	Address Code
Input Register	XW	0080	Word Address
Input Device	X		Word Address
Output Register	YW	0081	Word Address
Output Device	Y		Word Address
Auxiliary Register	RW	0084	Word Address
Auxiliary Relay	R		Word Address
Timer Register	T	0060	Word Address
Counter Register	C	0061	Word Address
Data Register	D	0000	Word Address
Link Relay Register	ZW	0086	Word Address
Link Relay Device	Z		Word Address

8 Error Messages

Error messages are displayed on the Display screen as follows: "No. : Device Name: Error Message(Error Occurrence Area)". Each description is shown below.

Item	Description
No.	Error No.
Device Name	Name of the External Device where an error occurs. Device name is a title of the External Device set with GP-Pro EX. (Initial value [PLC1])
Error Message	Displays messages related to the error that has occurred.
Error Occurrence Area	<p>Displays IP address or device address of the External Device where an error occurs, or error codes received from the External Device.</p> <p>NOTE</p> <ul style="list-style-type: none"> • IP address is displayed such as "IP address (Decimal): MAC address (Hex)". • Device address is displayed as "Address: Device address". • Received error codes are displayed such as "Decimal [Hex]".

Display Examples of Error Messages

"RHAA035: PLC1: Error has been responded for device write command (Error Code: 1[01H])"

NOTE

- Refer to your External Device manual for details on received error codes.
- Refer to "Display-related errors" in "Maintenance/Troubleshooting Guide" for details on the error messages common to the driver.

■ Error Codes Specific to the External Device

Error codes specific to the External Device are shown below.

Error Code	Description
115(73H)	Register No/Size error.This error occurs when you access the address beyond the range in T Series or V Series.
9(9H)	Register No/Size error.This error occurs when you access the address beyond the range in EX Series.
2(2H)	Transmission format error. This error occurs when you access a nonexistent device.

