



Temperature Controller MODBUS SIO Driver

1	System Configuration.....	3
2	Selection of External Device	10
3	Example of Communication Setting	11
4	Setup Items	72
5	Cable Diagram	77
6	Supported Device.....	179
7	Device Code and Address Code.....	190
8	Error Messages	192

Introduction

This manual describes how to connect the Display and the External Device (target Temperature Controller).

In this manual, the connection procedure will be described by following the below sections:

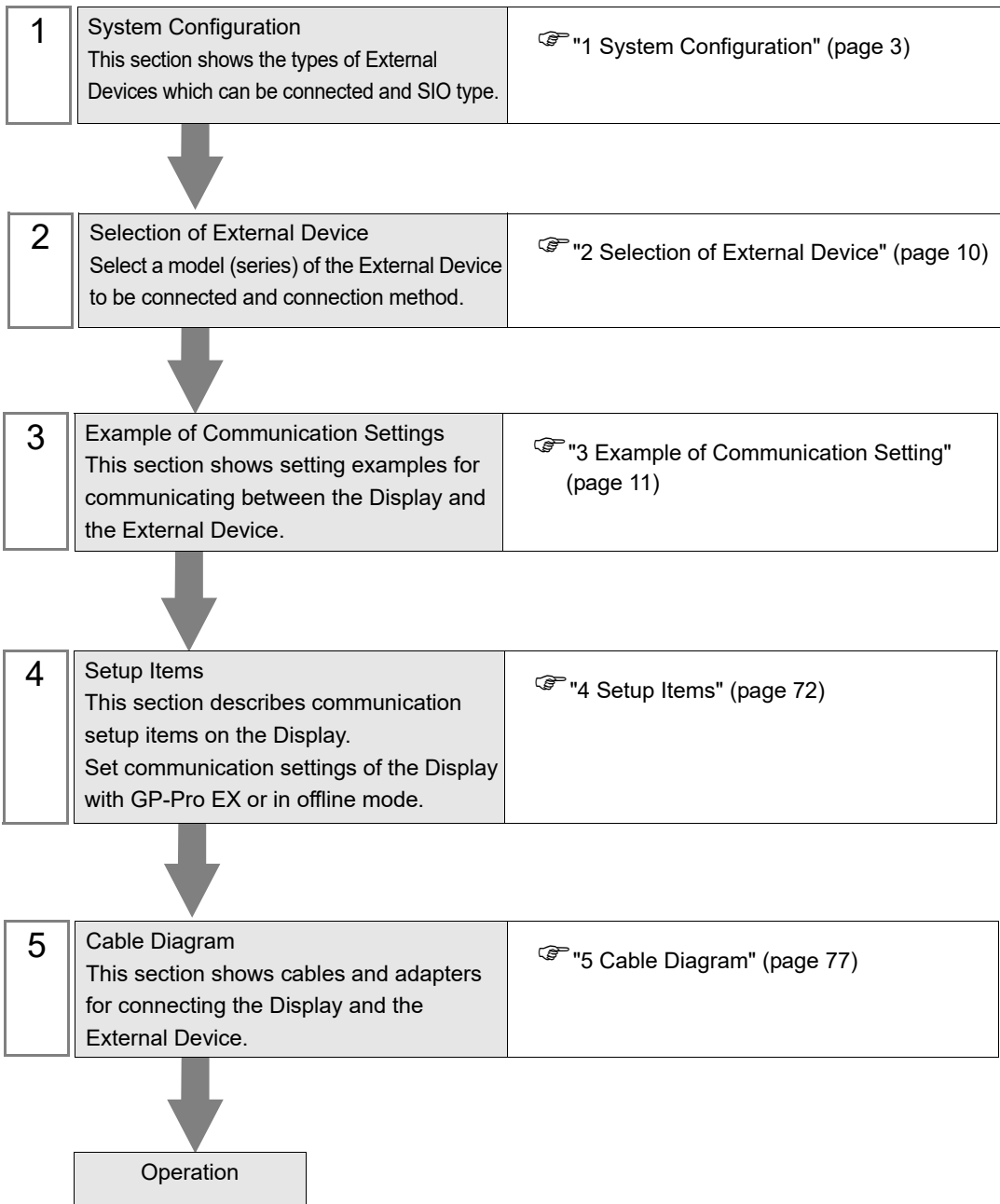

1 System Configuration

The system configuration in the case when the External Device of RKC INSTRUMENT INC. and the Display are connected is shown.

Series	CPU	Link I/F	SIO Type	Setting Example	Cable Diagram
CB	CB100□□□□-□□*□□-5□/□Z-1021 CB400□□□□-□□*□□-5□/□Z-1021 CB500□□□□-□□*□□-5□/□Z-1021 CB700□□□□-□□*□□-5□/□Z-1021 CB900□□□□-□□*□□-5□/□Z-1021	Terminal block on the controller	RS422/485(2 wire)	Setting Example 1 (page 11)	Cable Diagram 3 (page 85)
FB400/ FB900	FB900-□□-□*□□□1/□□-□□□□ FB400-□□-□*□□□1/□□-□□□□	Terminal block on the controller	RS232C	Setting Example 2 (page 13)	Cable Diagram 6 (page 114)
	FB900-□□-□*□□□4/□□-□□□□ FB400-□□-□*□□□4/□□-□□□□	Terminal block on the controller	RS422/485(4 wire)	Setting Example 3 (page 15)	Cable Diagram 7 (page 116)
	FB900-□□-□*□□□5/□□-□□□□ FB900-□□-□*□□□X/□□-□□□□ FB900-□□-□*□□□Y/□□-□□□□ FB400-□□-□*□□□5/□□-□□□□ FB400-□□-□*□□□X/□□-□□□□ FB400-□□-□*□□□Y/□□-□□□□	Terminal block on the controller	RS422/485(2 wire)	Setting Example 4 (page 17)	Cable Diagram 3 (page 85)
	FB900-□□-□*□□□W/□□-□□□□	Terminal block on the controller	RS232C	Setting Example 2 (page 13)	Cable Diagram 6 (page 114)
	FB400-□□-□*□□□W/□□-□□□□	Terminal block on the controller	RS422/485(2 wire)	Setting Example 4 (page 17)	Cable Diagram 3 (page 85)
HA400/ HA900	HA900-□□-□□-□*□□-□□6□-□/□/□ HA900-□□-□□-□*□□-□□□6□-□/□/□ HA901-□□-□□-□*□□-□□6□-□/□/□ HA901-□□-□□-□*□□-□□□6□-□/□/□ HA400-□□-□□-□*□□-□□6□-□/□/□ HA400-□□-□□-□*□□-□□□6□-□/□/□ HA401-□□-□□-□*□□-□□6□-□/□/□ HA401-□□-□□-□*□□-□□□6□-□/□/□	Terminal block on the controller	RS422/485(2 wire)	Setting Example 5 (page 19)	Cable Diagram 3 (page 85)
	HA900-□□-□□-□*□□-□□8□-□/□/□ HA900-□□-□□-□*□□-□□□8□-□/□/□ HA901-□□-□□-□*□□-□□8□-□/□/□ HA901-□□-□□-□*□□-□□□8□-□/□/□ HA400-□□-□□-□*□□-□□8□-□/□/□ HA400-□□-□□-□*□□-□□□8□-□/□/□ HA401-□□-□□-□*□□-□□8□-□/□/□ HA401-□□-□□-□*□□-□□□8□-□/□/□	Terminal block on the controller	RS232C	Setting Example 6 (page 21)	Cable Diagram 6 (page 114)
	HA900-□□-□□-□*□□-□□□7-□/□/□ HA901-□□-□□-□*□□-□□□7-□/□/□ HA400-□□-□□-□*□□-□□□7-□/□/□ HA401-□□-□□-□*□□-□□□7-□/□/□	Terminal block on the controller	RS422/485(4 wire)	Setting Example 7 (page 23)	Cable Diagram 7 (page 116)

Series	CPU	Link I/F	SIO Type	Setting Example	Cable Diagram
MA900	MA900-4□□□□-□□-□*□□□-□6/□	Terminal block on the controller	RS422/485(2 wire)	Setting Example 8 (page 25)	Cable Diagram 3 (page 85)
	MA900-4□□□□-□□-□*□□□-□7/□	Terminal block on the controller	RS422/485(4 wire)	Setting Example 9 (page 27)	Cable Diagram 7 (page 116)
	MA900-4□□□□-□□-□*□□□-□8/□	Terminal block on the controller	RS232C	Setting Example 10 (page 29)	Cable Diagram 6 (page 114)
MA901	MA901-8□□□□-□□-□*□□□-□6/□	Terminal block on the controller	RS422/485(2 wire)	Setting Example 8 (page 25)	Cable Diagram 3 (page 85)
	MA901-8□□□□-□□-□*□□□-□7/□	Terminal block on the controller	RS422/485(4 wire)	Setting Example 9 (page 27)	Cable Diagram 7 (page 116)
	MA901-8□□□□-□□-□*□□□-□8/□	Terminal block on the controller	RS232C	Setting Example 10 (page 29)	Cable Diagram 6 (page 114)
SRV	V-TIO-A-□□□□-□□*□□□-□□-□□ V-TIO-C-□□□□-□□*□□□-□□-□□	Terminal block on the controller	RS422/485(2 wire)	Setting Example 14 (page 37)	Cable Diagram 3 (page 85)
SRX	X-TIO-A-□□-□□*□□	Terminal block on the controller	RS422/485(2 wire)	Setting Example 14 (page 37)	Cable Diagram 3 (page 85)
SA100	SA100□□□□-□□-□*□□-6□□□	Terminal block on the controller	RS422/485(2 wire)	Setting Example 16 (page 41)	Cable Diagram 3 (page 85)
SA200	SA200□□□□-□□-□*□□-6□□□	Terminal block on the controller	RS422/485(2 wire)	Setting Example 16 (page 41)	Cable Diagram 3 (page 85)
SR Mini HG (H-PCP-A)	H-PCP-A-□1N-□*□□Z-1021	Terminal block on the controller	RS232C	Setting Example 18 (page 45)	Cable Diagram 1 (page 77)
	H-PCP-A-□4N-□*□□Z-1021	Terminal block on the controller	RS422/485(4 wire)	Setting Example 19 (page 47)	Cable Diagram 2 (page 79)

Series	CPU	Link I/F	SIO Type	Setting Example	Cable Diagram
SR Mini HG (H-PCP-J)	H-PCP-J-□4-□-D*□□	Connector on the controller	RS422/ 485(4 wire)	Setting Example 20 (page 49)	Cable Diagram 4 (page 94)
	H-PCP-J-□5-□-D*□□	Connector on the controller	RS422/ 485(2 wire)	Setting Example 21 (page 52)	Cable Diagram 5 (page 101)
	H-PCP-J-□□1-D*□□	Connector on the controller	RS232C	Setting Example 22 (page 55)	Cable Diagram 1 (page 77)
	H-PCP-J-□□4-D*□□	Connector on the controller	RS422/ 485(4 wire)	Setting Example 20 (page 49)	Cable Diagram 8 (page 122)
	H-PCP-J-□□5-D*□□	Connector on the controller	RS422/ 485(2 wire)	Setting Example 21 (page 52)	Cable Diagram 9 (page 131)
SRZ (Z-TIO)	Z-TIO-A-□-□□□□/□□-□□□□ Z-TIO-B-□-□□/□N□-□□□□ Z-TIO-C-□-□□□□/□□-□□□□ Z-TIO-D-□-□□/□N□-□□□□	Terminal block on the controller	RS422/ 485(2 wire)	Setting Example 23 (page 58)	Cable Diagram 10 (page 144)
SRZ (Z-DIO)	Z-DIO-A-□-□□/□-□□□□□□□□ Z-DIO-A-□-□□/□N	Terminal block on the controller	RS422/ 485(2 wire)	Setting Example 24 (page 60)	Cable Diagram 10 (page 144)
SRZ (Z-CT)	Z-CT-A-□-□-□□ Z-CT-A-□□/□N	Terminal block on the controller	RS422/ 485(2 wire)	Setting Example 25 (page 62)	Cable Diagram 10 (page 144)
SRZ (Z-COM)	Z-COM-A-4□/□□□□ Z-COM-A-4□□/□N	COM.PORT1 or COM.PORT2 on the controller	RS422/ 485(4 wire)	Setting Example 26 (page 64)	Cable Diagram 11 (page 157)
	Z-COM-A-5□/□□□□ Z-COM-A-5□□/□N		RS422/ 485(2 wire)	Setting Example 27 (page 66)	Cable Diagram 12 (page 166)
	Z-COM-A-□4/□□□□ Z-COM-A-□4□/□N	COM.PORT3 or COM.PORT4 on the controller	RS422/ 485(4 wire)	Setting Example 28 (page 68)	Cable Diagram 11 (page 157)
	Z-COM-A-□5/□□□□ Z-COM-A-□5□/□N		RS422/ 485(2 wire)	Setting Example 29 (page 70)	Cable Diagram 12 (page 166)

■ Connection Configuration

- 1:1 Connection



- 1:n Connection

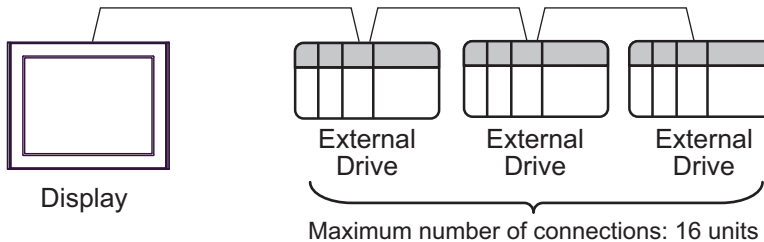

- 1:n Connection (For the SRZ (Z-TIO), SRZ (Z-DIO), and SRZ (Z-CT) Series)

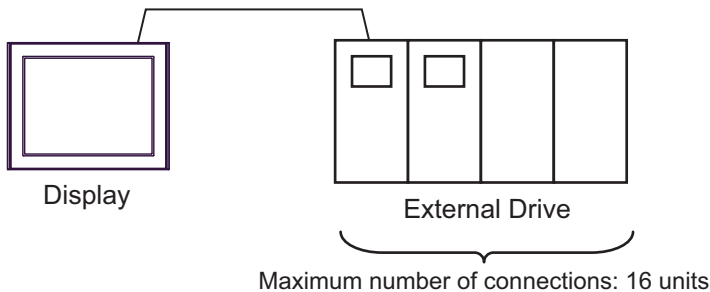

- 1:n Connection (For the SRZ (Z-COM) Series)

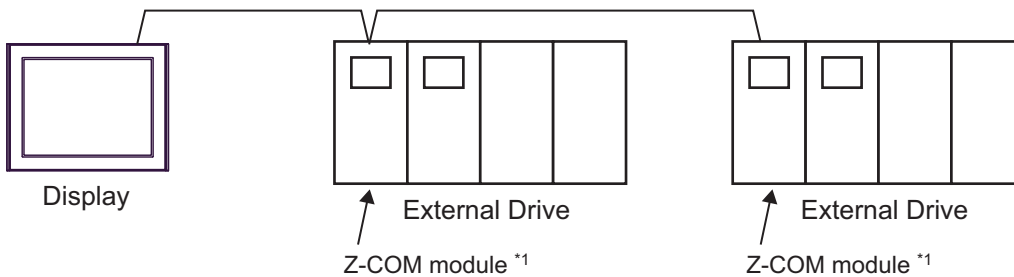

*1 Up to 16 Z-COM modules can be connected.

■ IPC COM Port

When connecting IPC with an External Device, the COM port used depends on the series and SIO type. Please refer to the IPC manual for details.

Usable port

Series	Usable Port		
	RS-232C	RS-422/485(4 wire)	RS-422/485(2 wire)
PS-2000B	COM1 ^{*1} , COM2, COM3 ^{*1} , COM4	-	-
PS-3450A, PS-3451A, PS3000-BA, PS3001-BD	COM1, COM2 ^{*1*2}	COM2 ^{*1*2}	COM2 ^{*1*2}
PS-3650A (T41 model), PS-3651A (T41 model)	COM1 ^{*1}	-	-
PS-3650A (T42 model), PS-3651A (T42 model)	COM1 ^{*1*2} , COM2	COM1 ^{*1*2}	COM1 ^{*1*2}
PS-3700A (Pentium®4-M) PS-3710A	COM1 ^{*1} , COM2 ^{*1} , COM3 ^{*2} , COM4	COM3 ^{*2}	COM3 ^{*2}
PS-3711A	COM1 ^{*1} , COM2 ^{*2}	COM2 ^{*2}	COM2 ^{*2}
PS4000 ^{*3}	COM1, COM2	-	-
PL3000	COM1 ^{*1*2} , COM2 ^{*1} , COM3, COM4	COM1 ^{*1*2}	COM1 ^{*1*2}
PE-4000B Atom N270	COM1, COM2	-	-
PE-4000B Atom N2600	COM1, COM2	COM3 ^{*4} , COM4 ^{*4} , COM5 ^{*4} , COM6 ^{*4}	COM3 ^{*4} , COM4 ^{*4} , COM5 ^{*4} , COM6 ^{*4}
PS5000 (Slim Panel Type Core i3 Model) ^{*5*6}	COM1, COM2 ^{*4}	COM2 ^{*4}	COM2 ^{*4}
PS5000 (Slim Panel Type Atom Model) ^{*5*6}	COM1, COM2 ^{*7}	COM2 ^{*7}	COM2 ^{*7}
PS5000 (Enclosed Panel Type) ^{*8}	COM1	-	-
PS5000 (Modular Type PFXPU/PFXPP) ^{*5*6} PS5000 (Modular Type PFXPL2B5-6)	COM1 ^{*7}	COM1 ^{*7}	COM1 ^{*7}
PS5000 (Modular Type PFXPL2B1-4)	COM1, COM2 ^{*7}	COM2 ^{*7}	COM2 ^{*7}
PS6000 (Advanced Box) PS6000 (Standard Box)	COM1 ^{*9}	*10	*10
PS6000 (Basic Box)	COM1 ^{*9}	COM1 ^{*9}	COM1 ^{*9}

*1 The RI/5V can be switched. Use the IPC's switch to change if necessary.

*2 Set up the SIO type with the DIP Switch. Please set up as follows according to SIO type to be used.

- *3 When making communication between an External Device and COM port on the Expansion slot, only RS-232C is supported. However, ER (DTR/CTS) control cannot be executed because of the specification of COM port.
For connection with External Device, use user-created cables and disable Pin Nos. 1, 4, 6 and 9. Please refer to the IPC manual for details of pin layout.
- *4 Set up the SIO type with the BIOS. Please refer to the IPC manual for details of BIOS.
- *5 When setting up communication between an External Device and the RS-232C/422/485 interface module, use the IPC (RS-232C) or PS5000 (RS-422/485) cable diagrams. However, when using PFXZPBMPR42P2 in a RS-422/485 (4-wire) configuration with no flow control, connect 7.RTS+ and 8.CTS+, and connect 6.RTS- and 9.CTS-.
When using RS-422/485 communication with External Devices, you may need to reduce the transmission speed and increase the TX Wait time.
- *6 To use RS-422/485 communication on the RS-232C/422/485 interface module, the DIP Switch setting is required. Please refer to "Knowledge Base" (FAQs) on the support site. (<http://www.pro-face.com/trans/en/manual/1001.html>)

Settings	FAQ ID
PFXZPBMPR42P2, RS422/485 change method	FA263858
PFXZPBMPR42P2 termination resistor setting	FA263974
PFXZPBMPR44P2, RS422/485 change method	FA264087
PFXZPBMPR44P2 termination resistor setting	FA264088

- *7 Set up the SIO type with the DIP Switch. Please refer to the IPC manual for details of DIP Switch. The BOX Atom has not a switch to set the RS-232C, RS-422/485 mode. Use the BIOS for the setting.
- *8 For the connection with the External Device, on the user-created cable read as if the connector on the Display-side is a M12 A-coding 8 pin socket. The pin assignment is the same as described in the cable diagram. For the M12 A-coding connector, use PFXZPSCNM122.
- *9 In addition to COM1, you can also use the COM port on the optional interface.
- *10 Install the optional interface in the expansion slot.

DIP Switch settings (PL3000 / PS3000 Series)

RS-232C

DIP Switch	Setting	Description
1	OFF*1	Reserved (always OFF)
2	OFF	SIO type: RS-232C
3	OFF	
4	OFF	Output mode of SD (TXD) data: Always output
5	OFF	Terminal resistance (220Ω) insertion to SD (TXD): None
6	OFF	Terminal resistance (220Ω) insertion to RD (RXD): None
7	OFF	Short-circuit of SDA (TXA) and RDA (RXA): Not available
8	OFF	Short-circuit of SDB (TXB) and RDB (RXB): Not available
9	OFF	RS (RTS) Auto control mode: Disabled
10	OFF	

*1 When using PS-3450A, PS-3451A, PS3000-BA and PS3001-BD, turn ON the set value.

RS-422/485 (4 wire)

DIP Switch	Setting	Description
1	OFF	Reserved (always OFF)
2	ON	SIO type: RS-422/485
3	ON	
4	OFF	Output mode of SD (TXD) data: Always output
5	OFF	Terminal resistance (220Ω) insertion to SD (TXD): None
6	OFF	Terminal resistance (220Ω) insertion to RD (RXD): None
7	OFF	Short-circuit of SDA (TXA) and RDA (RXA): Not available
8	OFF	Short-circuit of SDB (TXB) and RDB (RXB): Not available
9	OFF	RS (RTS) Auto control mode: Disabled
10	OFF	

RS-422/485 (2 wire)

DIP Switch	Setting	Description
1	OFF	Reserved (always OFF)
2	ON	SIO type: RS-422/485
3	ON	
4	OFF	Output mode of SD (TXD) data: Always output
5	OFF	Terminal resistance (220Ω) insertion to SD (TXD): None
6	OFF	Terminal resistance (220Ω) insertion to RD (RXD): None
7	ON	Short-circuit of SDA (TXA) and RDA (RXA): Available
8	ON	Short-circuit of SDB (TXB) and RDB (RXB): Available
9	ON	RS (RTS) Auto control mode: Enabled
10	ON	

2 Selection of External Device

Select the External Device to be connected to the Display.

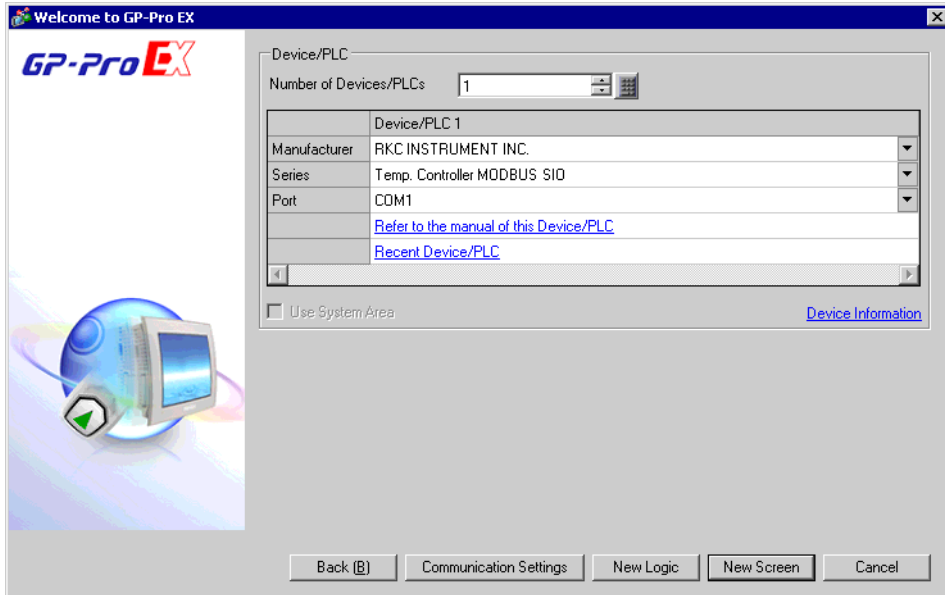

Setup Items	Setup Description
Number of Devices/PLCs	Enter an integer from 1 to 4 to define the number of Devices/PLCs to connect to the display.
Manufacturer	Select the manufacturer of the External Device to connect. Select "RKC INSTRUMENT INC.".
Series	Select the External Device model (series) and the connection method. Select "Temp. Controller MODBUS SIO". In System configuration, make sure the External Device you are connecting is supported by "Temp. Controller MODBUS SIO". ☞ "1 System Configuration" (page 3)
Port	Select the Display port to be connected to the External Device.
Use System Area	Not available in this driver.

3 Example of Communication Setting

Examples of communication settings of the Display and the External Device, recommended by Digital Electronics Corp., are shown.

3.1 Setting Example 1

■ Settings of GP-Pro EX

◆ Communication Settings

To display the setup screen, from the [Project] menu, point to [System Settings] and select [Device/PLC].

Device/PLC 1

Summary [Change Device/PLC](#)

Manufacturer Series Port

Text Data Mode [Change](#)

Communication Settings

SIO Type RS232C RS422/485(2wire) RS422/485(4wire)

Speed

Data Length 7 8

Parity NONE EVEN ODD

Stop Bit 1 2

Flow Control NONE ER(DTR/CTS) XON/XOFF

Timeout (sec)

Retry

Wait To Send (ms)

RI / VCC RI VCC

In the case of RS232C, you can select the 9th pin to RI (Input) or VCC (5V Power Supply). If you use the Digital's RS232C Isolation Unit, please select it to VCC.

[Default](#)

Device-Specific Settings

Allowable Number of Devices/PLCs: 16 [Add Device](#)

No.	Device Name	Settings	Add Indirect Device
1	PLC1	Series=CB, Slave Address=1	+

NOTE

- Setting value for Wait To Send differs depending on the External Device. Please refer to the manual of the External Device for more details.
- If you do not set up sufficient Wait To Send time, a communication error may occur.

◆ Device Setting

To display the [Individual Device Settings] dialog box, from [Device-Specific Settings] in the [Device/PLC] window, select the external device and click [Settings] .

To connect multiple External Devices, from [Device-Specific Settings] in the [Device/PLC] window, click [Add Device] to add another External Device.



■ Settings of External Device

Use the SET key, shift key, down key and up key on the front of the Temperature Controller for communication settings of the External Device.

Please refer to the manual of the Temperature Controller for more details.

◆ Procedure

1. While pressing down the SET key, press the shift key to move from the PV/SV display mode to the communication setting mode.
2. Press the SET key to select the parameter.
3. Press the down/up keys to change the setting.
4. While pressing down the SET key, press the shift key to move from the communication setting mode to the PV/SV display mode.
5. To confirm the setting, restart the Temperature Controller.

◆ Setting Value

Add	1
bPS	2
bIT	0

NOTE • Parameters to be set vary depending on the Temperature Controller. Please refer to the manual of the Temperature Controller for more details.

3.2 Setting Example 2

■ Settings of GP-Pro EX

◆ Communication Settings

To display the setup screen, from the [Project] menu, point to [System Settings] and select [Device/PLC].

Device/PLC 1

Summary [Change Device/PLC](#)

Manufacturer Series Port

Text Data Mode [Change](#)

Communication Settings

SIO Type RS232C RS422/485(2wire) RS422/485(4wire)

Speed

Data Length 7 8

Parity NONE EVEN ODD

Stop Bit 1 2

Flow Control NONE ER(DTR/CTS) XON/XOFF

Timeout (sec)

Retry

Wait To Send (ms)

RI / VCC RI VCC

In the case of RS232C, you can select the 9th pin to RI (Input) or VCC (5V Power Supply). If you use the Digital's RS232C Isolation Unit, please select it to VCC.

[Default](#)

Device-Specific Settings

Allowable Number of Devices/PLCs 16 [Add Device](#)

No.	Device Name	Settings	Add Indirect Device
1	PLC1	Series=FB400/900,Slave Address=1	+

- NOTE**
- Setting value for Wait To Send differs depending on the External Device. Please refer to the manual of the External Device for more details.
 - If you do not set up sufficient Wait To Send time, a communication error may occur.

◆ Device Setting

To display the [Individual Device Settings] dialog box, from [Device-Specific Settings] in the [Device/PLC] window, select the external device and click [Settings] .

To connect multiple External Devices, from [Device-Specific Settings] in the [Device/PLC] window, click [Add Device] to add another External Device.



■ Settings of External Device

Use the SET key, shift key, down key and up key on the front of the Temperature Controller for communication settings of the External Device.

Please refer to the manual of the Temperature Controller for more details.

◆ Procedure

1. While pressing down the SET key, press and hold the shift key to move from the PV/SV display mode to the engineering mode.
2. Press the up key several times to specify F60, and press the SET key.
3. Set 1 for CMP1.
4. While pressing down the SET key, press the shift key to move from the engineering mode to the PV/SV display mode.
5. While pressing down the SET key, press the shift key to move from the PV/SV display mode to the setup setting mode.
6. Press the SET key several times to select the parameter.
7. Press the down/up keys to change the setting.
8. While pressing down the SET key, press the shift key to move from the setup setting mode to the PV/SV display mode.
9. To confirm the setting, restart the Temperature Controller.

Setting Value

Add1	1
bPS1	9.6
bIT1	8n1

NOTE • Parameters to be set vary depending on the Temperature Controller. Please refer to the manual of the Temperature Controller for more details.

3.3 Setting Example 3

■ Settings of GP-Pro EX

◆ Communication Settings

To display the setup screen, from the [Project] menu, point to [System Settings] and select [Device/PLC].

Device/PLC 1

Summary [Change Device/PLC](#)

Manufacturer Series Port

Text Data Mode [Change](#)

Communication Settings

SIO Type RS232C RS422/485(2wire) RS422/485(4wire)

Speed

Data Length 7 8

Parity NONE EVEN ODD

Stop Bit 1 2

Flow Control NONE ER(DTR/CTS) XON/XOFF

Timeout (sec)

Retry

Wait To Send (ms)

RI / VCC RI VCC

In the case of RS232C, you can select the 9th pin to RI (Input) or VCC (5V Power Supply). If you use the Digital's RS232C Isolation Unit, please select it to VCC.

[Default](#)

Device-Specific Settings

Allowable Number of Devices/PLCs 16 [Add Device](#)

No.	Device Name	Settings	Add Indirect Device
1	PLC1	Series=FB400/900,Slave Address=1	+

- NOTE**
- Setting value for Wait To Send differs depending on the External Device. Please refer to the manual of the External Device for more details.
 - If you do not set up sufficient Wait To Send time, a communication error may occur.

◆ Device Setting

To display the [Individual Device Settings] dialog box, from [Device-Specific Settings] in the [Device/PLC] window, select the external device and click [Settings] .

To connect multiple External Devices, from [Device-Specific Settings] in the [Device/PLC] window, click [Add Device] to add another External Device.



■ Settings of External Device

Use the SET key, shift key, down key and up key on the front of the Temperature Controller for communication settings of the External Device.

Please refer to the manual of the Temperature Controller for more details.

◆ Procedure

1. While pressing down the SET key, press and hold the shift key to move from the PV/SV display mode to the engineering mode.
2. Press the up key several times to specify F60, and press the SET key.
3. Set 1 for CMP1.
4. While pressing down the SET key, press the shift key to move from the engineering mode to the PV/SV display mode.
5. While pressing down the SET key, press the shift key to move from the PV/SV display mode to the setup setting mode.
6. Press the SET key several times to select the parameter.
7. Press the down/up keys to change the setting.
8. While pressing down the SET key, press the shift key to move from the setup setting mode to the PV/SV display mode.
9. To confirm the setting, restart the Temperature Controller.

◆ Setting Value

Add1	1
bPS1	9.6
bIT1	8n1

NOTE • Parameters to be set vary depending on the Temperature Controller. Please refer to the manual of the Temperature Controller for more details.

3.4 Setting Example 4

■ Settings of GP-Pro EX

◆ Communication Settings

To display the setup screen, from the [Project] menu, point to [System Settings] and select [Device/PLC].

Device/PLC 1

Summary [Change Device/PLC](#)

Manufacturer Series Port

Text Data Mode [Change](#)

Communication Settings

SIO Type RS232C RS422/485(2wire) RS422/485(4wire)

Speed

Data Length 7 8

Parity NONE EVEN ODD

Stop Bit 1 2

Flow Control NONE ER(DTR/CTS) XON/XOFF

Timeout (sec)

Retry

Wait To Send (ms)

RI / VCC RI VCC

In the case of RS232C, you can select the 9th pin to RI (Input) or VCC (5V Power Supply). If you use the Digital's RS232C Isolation Unit, please select it to VCC.

[Default](#)

Device-Specific Settings

Allowable Number of Devices/PLCs 16 [Add Device](#)

No.	Device Name	Settings	Add Indirect Device
1	PLC1	Series=FB400/900.Slave Address=1	+

- NOTE**
- Setting value for Wait To Send differs depending on the External Device. Please refer to the manual of the External Device for more details.
 - If you do not set up sufficient Wait To Send time, a communication error may occur.

◆ Device Setting

To display the [Individual Device Settings] dialog box, from [Device-Specific Settings] in the [Device/PLC] window, select the external device and click [Settings] .

To connect multiple External Devices, from [Device-Specific Settings] in the [Device/PLC] window, click [Add Device] to add another External Device.



■ Settings of External Device

Use the SET key, shift key, down key and up key on the front of the Temperature Controller for communication settings of the External Device.

Please refer to the manual of the Temperature Controller for more details.

◆ Procedure

1. While pressing down the SET key, press and hold the shift key to move from the PV/SV display mode to the engineering mode.
2. Press the up key several times to specify F60, and press the SET key.
3. Set 1 for CMP1.
4. While pressing down the SET key, press the shift key to move from the engineering mode to the PV/SV display mode.
5. While pressing down the SET key, press the shift key to move from the PV/SV display mode to the setup setting mode.
6. Press the SET key several times to select the parameter.
7. Press the down/up keys to change the setting.
8. While pressing down the SET key, press the shift key to move from the setup setting mode to the PV/SV display mode.
9. To confirm the setting, restart the Temperature Controller.

◆ Setting Value

Add1	1
bPS1	9.6
bIT1	8n1

NOTE

- Parameters to be set vary depending on the Temperature Controller. Please refer to the manual of the Temperature Controller for more details.

3.5 Setting Example 5

■ Settings of GP-Pro EX

◆ Communication Settings

To display the setup screen, from the [Project] menu, point to [System Settings] and select [Device/PLC].

Device/PLC 1

Summary [Change Device/PLC](#)

Manufacturer Series Port

Text Data Mode [Change](#)

Communication Settings

SIO Type RS232C RS422/485(2wire) RS422/485(4wire)

Speed

Data Length 7 8

Parity NONE EVEN ODD

Stop Bit 1 2

Flow Control NONE ER(DTR/CTS) XON/XOFF

Timeout (sec)

Retry

Wait To Send (ms)

RI / VCC RI VCC

In the case of RS232C, you can select the 9th pin to RI (Input) or VCC (5V Power Supply). If you use the Digital's RS232C Isolation Unit, please select it to VCC.

[Default](#)

Device-Specific Settings

Allowable Number of Devices/PLCs 16 [Add Device](#)

No.	Device Name	Settings	Add Indirect Device
1	PLC1	Series=HA400/900,Slave Address=1	+

NOTE

- Setting value for Wait To Send differs depending on the External Device. Please refer to the manual of the External Device for more details.
- If you do not set up sufficient Wait To Send time, a communication error may occur.

◆ Device Setting

To display the [Individual Device Settings] dialog box, from [Device-Specific Settings] in the [Device/PLC] window, select the external device and click [Settings] .

To connect multiple External Devices, from [Device-Specific Settings] in the [Device/PLC] window, click [Add Device] to add another External Device.



■ Settings of External Device

Use the SET key, shift key, down key and up key on the front of the Temperature Controller for communication settings of the External Device.

Please refer to the manual of the Temperature Controller for more details.

◆ Procedure

1. While pressing down the SET key, press the shift key to move from the SV setting & monitor mode to the setup setting mode.
2. Press the SET key several times to select the parameter.
3. Press the down/up keys to change the setting.
4. While pressing down the SET key, press the shift key to move from the setup setting mode to the SV setting & monitor mode.
5. To confirm the setting, restart the Temperature Controller.

◆ Setting Value

Add1	1
bPS1	9.6
bIT1	8n1

NOTE • Parameters to be set vary depending on the Temperature Controller. Please refer to the manual of the Temperature Controller for more details.

3.6 Setting Example 6

■ Settings of GP-Pro EX

◆ Communication Settings

To display the setup screen, from the [Project] menu, point to [System Settings] and select [Device/PLC].

Device/PLC 1

Summary [Change Device/PLC](#)

Manufacturer Series Port

Text Data Mode [Change](#)

Communication Settings

SIO Type RS232C RS422/485(2wire) RS422/485(4wire)

Speed

Data Length 7 8

Parity NONE EVEN ODD

Stop Bit 1 2

Flow Control NONE ER(DTR/CTS) XON/XOFF

Timeout (sec)

Retry

Wait To Send (ms)

RI / VCC RI VCC

In the case of RS232C, you can select the 9th pin to RI (Input) or VCC (5V Power Supply). If you use the Digital's RS232C Isolation Unit, please select it to VCC.

[Default](#)

Device-Specific Settings

Allowable Number of Devices/PLCs 16 [Add Device](#)

No.	Device Name	Settings	Add Indirect Device
1	PLC1	Series=HA400/900,Slave Address=1	+

- NOTE**
- Setting value for Wait To Send differs depending on the External Device. Please refer to the manual of the External Device for more details.
 - If you do not set up sufficient Wait To Send time, a communication error may occur.

◆ Device Setting

To display the [Individual Device Settings] dialog box, from [Device-Specific Settings] in the [Device/PLC] window, select the external device and click [Settings] .

To connect multiple External Devices, from [Device-Specific Settings] in the [Device/PLC] window, click [Add Device] to add another External Device.



■ Settings of External Device

Use the SET key, shift key, down key and up key on the front of the Temperature Controller for communication settings of the External Device.

Please refer to the manual of the Temperature Controller for more details.

◆ Procedure

1. While pressing down the SET key, press the shift key to move from the SV setting & monitor mode to the setup setting mode.
2. Press the SET key several times to select the parameter.
3. Press the down/up keys to change the setting.
4. While pressing down the SET key, press the shift key to move from the setup setting mode to the SV setting & monitor mode.
5. To confirm the setting, restart the Temperature Controller.

◆ Setting Value

Add1	1
bPS1	9.6
bIT1	8n1

NOTE • Parameters to be set vary depending on the Temperature Controller. Please refer to the manual of the Temperature Controller for more details.

3.7 Setting Example 7

■ Settings of GP-Pro EX

◆ Communication Settings

To display the setup screen, from the [Project] menu, point to [System Settings] and select [Device/PLC].

Device/PLC 1

Summary [Change Device/PLC](#)

Manufacturer Series Port

Text Data Mode [Change](#)

Communication Settings

SIO Type RS232C RS422/485(2wire) RS422/485(4wire)

Speed

Data Length 7 8

Parity NONE EVEN ODD

Stop Bit 1 2

Flow Control NONE ER(DTR/CTS) XON/XOFF

Timeout (sec)

Retry

Wait To Send (ms)

RI / VCC RI VCC

In the case of RS232C, you can select the 9th pin to RI (Input) or VCC (5V Power Supply). If you use the Digital's RS232C Isolation Unit, please select it to VCC.

[Default](#)

Device-Specific Settings

Allowable Number of Devices/PLCs 16 [Add Device](#)

No.	Device Name	Settings	Add Indirect Device
1	PLC1	Series=HA400/900,Slave Address=1	+

- NOTE**
- Setting value for Wait To Send differs depending on the External Device. Please refer to the manual of the External Device for more details.
 - If you do not set up sufficient Wait To Send time, a communication error may occur.

◆ Device Setting

To display the [Individual Device Settings] dialog box, from [Device-Specific Settings] in the [Device/PLC] window, select the external device and click [Settings] .

To connect multiple External Devices, from [Device-Specific Settings] in the [Device/PLC] window, click [Add Device] to add another External Device.



■ Settings of External Device

Use the SET key, shift key, down key and up key on the front of the Temperature Controller for communication settings of the External Device.

Please refer to the manual of the Temperature Controller for more details.

◆ Procedure

1. While pressing down the SET key, press the shift key to move from the SV setting & monitor mode to the setup setting mode.
2. Press the SET key several times to select the parameter.
3. Press the down/up keys to change the setting.
4. While pressing down the SET key, press the shift key to move from the setup setting mode to the SV setting & monitor mode.
5. To confirm the setting, restart the Temperature Controller.

◆ Setting Value

Add1	1
bPS1	9.6
bIT1	8n1

NOTE

- Parameters to be set vary depending on the Temperature Controller. Please refer to the manual of the Temperature Controller for more details.

3.8 Setting Example 8

■ Settings of GP-Pro EX

◆ Communication Settings

To display the setup screen, from the [Project] menu, point to [System Settings] and select [Device/PLC].

Device/PLC 1

Summary [Change Device/PLC](#)

Manufacturer Series Port

Text Data Mode [Change](#)

Communication Settings

SIO Type RS232C RS422/485(2wire) RS422/485(4wire)

Speed

Data Length 7 8

Parity NONE EVEN ODD

Stop Bit 1 2

Flow Control NONE ER(DTR/CTS) XON/XOFF

Timeout (sec)

Retry

Wait To Send (ms)

RI / VCC RI VCC

In the case of RS232C, you can select the 9th pin to RI (Input) or VCC (5V Power Supply). If you use the Digital's RS232C Isolation Unit, please select it to VCC.

[Default](#)

Device-Specific Settings

Allowable Number of Devices/PLCs 16 [Add Device](#)

No.	Device Name	Settings	Add Indirect Device
1	PLC1	Series=MA900,Slave Address=1	+

- NOTE**
- Setting value for Wait To Send differs depending on the External Device. Please refer to the manual of the External Device for more details.
 - If you do not set up sufficient Wait To Send time, a communication error may occur.

◆ Device Setting

To display the [Individual Device Settings] dialog box, from [Device-Specific Settings] in the [Device/PLC] window, select the external device and click [Settings] .

To connect multiple External Devices, from [Device-Specific Settings] in the [Device/PLC] window, click [Add Device] to add another External Device.



■ Settings of External Device

Use the SET key, shift key, down key and up key on the front of the Temperature Controller for communication settings of the External Device.

Please refer to the manual of the Temperature Controller for more details.

◆ Procedure

1. While pressing down the SET key, press the <R/S key to move from the PV/SV monitor mode to the setup setting mode.
2. Press the SET key several times to select the parameter.
3. Press the down/up keys and the <R/S key to change the setting.
4. While pressing down the SET key, press the <R/S key to move from the setup setting mode to the PV/SV monitor mode.
5. To confirm the setting, restart the Temperature Controller.

◆ Setting Value

Add	1
bPS	960
bIT	8n1

NOTE

- Parameters to be set vary depending on the Temperature Controller. Please refer to the manual of the Temperature Controller for more details.

3.9 Setting Example 9

■ Settings of GP-Pro EX

◆ Communication Settings

To display the setup screen, from the [Project] menu, point to [System Settings] and select [Device/PLC].

Device/PLC 1

Summary [Change Device/PLC](#)

Manufacturer Series Port

Text Data Mode [Change](#)

Communication Settings

SIO Type RS232C RS422/485(2wire) RS422/485(4wire)

Speed

Data Length 7 8

Parity NONE EVEN ODD

Stop Bit 1 2

Flow Control NONE ER(DTR/CTS) XON/XOFF

Timeout (sec)

Retry

Wait To Send (ms)

RI / VCC RI VCC

In the case of RS232C, you can select the 9th pin to RI (Input) or VCC (5V Power Supply). If you use the Digital's RS232C Isolation Unit, please select it to VCC.

[Default](#)

Device-Specific Settings

Allowable Number of Devices/PLCs 16 [Add Device](#)

No.	Device Name	Settings	Add Indirect Device
1	PLC1	Series=MA900,Slave Address=1	+

- NOTE**
- Setting value for Wait To Send differs depending on the External Device. Please refer to the manual of the External Device for more details.
 - If you do not set up sufficient Wait To Send time, a communication error may occur.

◆ Device Setting

To display the [Individual Device Settings] dialog box, from [Device-Specific Settings] in the [Device/PLC] window, select the external device and click [Settings] .

To connect multiple External Devices, from [Device-Specific Settings] in the [Device/PLC] window, click [Add Device] to add another External Device.



■ Settings of External Device

Use the SET key, shift key, down key and up key on the front of the Temperature Controller for communication settings of the External Device.

Please refer to the manual of the Temperature Controller for more details.

◆ Procedure

1. While pressing down the SET key, press the <R/S key to move from the PV/SV monitor mode to the setup setting mode.
2. Press the SET key several times to select the parameter.
3. Press the down/up keys and the <R/S key to change the setting.
4. While pressing down the SET key, press the <R/S key to move from the setup setting mode to the PV/SV monitor mode.
5. To confirm the setting, restart the Temperature Controller.

◆ Setting Value

Add	1
bPS	960
bIT	8n1

NOTE

- Parameters to be set vary depending on the Temperature Controller. Please refer to the manual of the Temperature Controller for more details.

3.10 Setting Example 10

■ Settings of GP-Pro EX

◆ Communication Settings

To display the setup screen, from the [Project] menu, point to [System Settings] and select [Device/PLC].

Device/PLC 1

Summary [Change Device/PLC](#)

Manufacturer Series Port

Text Data Mode [Change](#)

Communication Settings

SIO Type RS232C RS422/485(2wire) RS422/485(4wire)

Speed

Data Length 7 8

Parity NONE EVEN ODD

Stop Bit 1 2

Flow Control NONE ER(DTR/CTS) XON/XOFF

Timeout (sec)

Retry

Wait To Send (ms)

RI / VCC RI VCC

In the case of RS232C, you can select the 9th pin to RI (Input) or VCC (5V Power Supply). If you use the Digital's RS232C Isolation Unit, please select it to VCC.

[Default](#)

Device-Specific Settings

Allowable Number of Devices/PLCs 16 [Add Device](#)

No.	Device Name	Settings	Add Indirect Device
1	PLC1	Series=MA900,Slave Address=1	+

NOTE

- Setting value for Wait To Send differs depending on the External Device. Please refer to the manual of the External Device for more details.
- If you do not set up sufficient Wait To Send time, a communication error may occur.

◆ Device Setting

To display the [Individual Device Settings] dialog box, from [Device-Specific Settings] in the [Device/PLC] window, select the external device and click [Settings] .

To connect multiple External Devices, from [Device-Specific Settings] in the [Device/PLC] window, click [Add Device] to add another External Device.



■ Settings of External Device

Use the SET key, shift key, down key and up key on the front of the Temperature Controller for communication settings of the External Device.

Please refer to the manual of the Temperature Controller for more details.

◆ Procedure

1. While pressing down the SET key, press the <R/S key to move from the PV/SV monitor mode to the setup setting mode.
2. Press the SET key several times to select the parameter.
3. Press the down/up keys and the <R/S key to change the setting.
4. While pressing down the SET key, press the <R/S key to move from the setup setting mode to the PV/SV monitor mode.
5. To confirm the setting, restart the Temperature Controller.

◆ Setting Value

Add	1
bPS	960
bIT	8n1

NOTE

- Parameters to be set vary depending on the Temperature Controller. Please refer to the manual of the Temperature Controller for more details.

3.11 Setting Example 11

■ Settings of GP-Pro EX

◆ Communication Settings

To display the setup screen, from the [Project] menu, point to [System Settings] and select [Device/PLC].

Device/PLC 1

Summary [Change Device/PLC](#)

Manufacturer Series Port

Text Data Mode [Change](#)

Communication Settings

SIO Type RS232C RS422/485(2wire) RS422/485(4wire)

Speed

Data Length 7 8

Parity NONE EVEN ODD

Stop Bit 1 2

Flow Control NONE ER(DTR/CTS) XON/XOFF

Timeout (sec)

Retry

Wait To Send (ms)

RI / VCC RI VCC

In the case of RS232C, you can select the 9th pin to RI (Input) or VCC (5V Power Supply). If you use the Digital's RS232C Isolation Unit, please select it to VCC.

[Default](#)

Device-Specific Settings

Allowable Number of Devices/PLCs 16 [Add Device](#)

No.	Device Name	Settings	Add Indirect Device
1	PLC1	Series=MA901,Slave Address=1	+

- NOTE**
- Setting value for Wait To Send differs depending on the External Device. Please refer to the manual of the External Device for more details.
 - If you do not set up sufficient Wait To Send time, a communication error may occur.

◆ Device Setting

To display the [Individual Device Settings] dialog box, from [Device-Specific Settings] in the [Device/PLC] window, select the external device and click [Settings] .

To connect multiple External Devices, from [Device-Specific Settings] in the [Device/PLC] window, click [Add Device] to add another External Device.



■ Settings of External Device

Use the SET key, shift key, down key and up key on the front of the Temperature Controller for communication settings of the External Device.

Please refer to the manual of the Temperature Controller for more details.

◆ Procedure

1. While pressing down the SET key, press the <R/S key to move from the PV/SV monitor mode to the setup setting mode.
2. Press the SET key several times to select the parameter.
3. Press the down/up keys and the <R/S key to change the setting.
4. While pressing down the SET key, press the <R/S key to move from the setup setting mode to the PV/SV monitor mode.
5. To confirm the setting, restart the Temperature Controller.

◆ Setting Value

Add	1
bPS	960
bIT	8n1

NOTE

- Parameters to be set vary depending on the Temperature Controller. Please refer to the manual of the Temperature Controller for more details.

3.12 Setting Example 12

■ Settings of GP-Pro EX

◆ Communication Settings

To display the setup screen, from the [Project] menu, point to [System Settings] and select [Device/PLC].

Device/PLC 1

Summary [Change Device/PLC](#)

Manufacturer Series Port

Text Data Mode [Change](#)

Communication Settings

SIO Type RS232C RS422/485(2wire) RS422/485(4wire)

Speed

Data Length 7 8

Parity NONE EVEN ODD

Stop Bit 1 2

Flow Control NONE ER(DTR/CTS) XON/XOFF

Timeout (sec)

Retry

Wait To Send (ms)

RI / VCC RI VCC

In the case of RS232C, you can select the 9th pin to RI (Input) or VCC (5V Power Supply). If you use the Digital's RS232C Isolation Unit, please select it to VCC.

[Default](#)

Device-Specific Settings

Allowable Number of Devices/PLCs 16 [Add Device](#)

No.	Device Name	Settings	Add Indirect Device
1	PLC1	Series=MA901,Slave Address=1	+

- NOTE**
- Setting value for Wait To Send differs depending on the External Device. Please refer to the manual of the External Device for more details.
 - If you do not set up sufficient Wait To Send time, a communication error may occur.

◆ Device Setting

To display the [Individual Device Settings] dialog box, from [Device-Specific Settings] in the [Device/PLC] window, select the external device and click [Settings] .

To connect multiple External Devices, from [Device-Specific Settings] in the [Device/PLC] window, click [Add Device] to add another External Device.



■ Settings of External Device

Use the SET key, shift key, down key and up key on the front of the Temperature Controller for communication settings of the External Device.

Please refer to the manual of the Temperature Controller for more details.

◆ Procedure

1. While pressing down the SET key, press the <R/S key to move from the PV/SV monitor mode to the setup setting mode.
2. Press the SET key several times to select the parameter.
3. Press the down/up keys and the <R/S key to change the setting.
4. While pressing down the SET key, press the <R/S key to move from the setup setting mode to the PV/SV monitor mode.
5. To confirm the setting, restart the Temperature Controller.

◆ Setting Value

Add	1
bPS	960
bIT	8n1

NOTE

- Parameters to be set vary depending on the Temperature Controller. Please refer to the manual of the Temperature Controller for more details.

3.13 Setting Example 13

■ Settings of GP-Pro EX

◆ Communication Settings

To display the setup screen, from the [Project] menu, point to [System Settings] and select [Device/PLC].

Device/PLC 1

Summary [Change Device/PLC](#)

Manufacturer Series Port

Text Data Mode [Change](#)

Communication Settings

SIO Type RS232C RS422/485(2wire) RS422/485(4wire)

Speed

Data Length 7 8

Parity NONE EVEN ODD

Stop Bit 1 2

Flow Control NONE ER(DTR/CTS) XON/XOFF

Timeout (sec)

Retry

Wait To Send (ms)

RI / VCC RI VCC

In the case of RS232C, you can select the 9th pin to RI (Input) or VCC (5V Power Supply). If you use the Digital's RS232C Isolation Unit, please select it to VCC.

[Default](#)

Device-Specific Settings

Allowable Number of Devices/PLCs 16 [Add Device](#)

No.	Device Name	Settings	Add Indirect Device
1	PLC1	Series=MA901,Slave Address=1	+

- NOTE**
- Setting value for Wait To Send differs depending on the External Device. Please refer to the manual of the External Device for more details.
 - If you do not set up sufficient Wait To Send time, a communication error may occur.

◆ Device Setting

To display the [Individual Device Settings] dialog box, from [Device-Specific Settings] in the [Device/PLC] window, select the external device and click [Settings] .

To connect multiple External Devices, from [Device-Specific Settings] in the [Device/PLC] window, click [Add Device] to add another External Device.



■ Settings of External Device

Use the SET key, shift key, down key and up key on the front of the Temperature Controller for communication settings of the External Device.

Please refer to the manual of the Temperature Controller for more details.

◆ Procedure

1. While pressing down the SET key, press the <R/S key to move from the PV/SV monitor mode to the setup setting mode.
2. Press the SET key several times to select the parameter.
3. Press the down/up keys and the <R/S key to change the setting.
4. While pressing down the SET key, press the <R/S key to move from the setup setting mode to the PV/SV monitor mode.
5. To confirm the setting, restart the Temperature Controller.

◆ Setting Value

Add	1
bPS	960
bIT	8n1

NOTE • Parameters to be set vary depending on the Temperature Controller. Please refer to the manual of the Temperature Controller for more details.

3.14 Setting Example 14

■ Settings of GP-Pro EX

◆ Communication Settings

To display the setup screen, from the [Project] menu, point to [System Settings] and select [Device/PLC].

Device/PLC 1

Summary [Change Device/PLC](#)

Manufacturer Series Port

Text Data Mode [Change](#)

Communication Settings

SIO Type RS232C RS422/485(2wire) RS422/485(4wire)

Speed

Data Length 7 8

Parity NONE EVEN ODD

Stop Bit 1 2

Flow Control NONE ER(DTR/CTS) XON/XOFF

Timeout (sec)

Retry

Wait To Send (ms)

RI / VCC RI VCC

In the case of RS232C, you can select the 9th pin to RI (Input) or VCC (5V Power Supply). If you use the Digital's RS232C Isolation Unit, please select it to VCC.

[Default](#)

Device-Specific Settings

Allowable Number of Devices/PLCs 16 [Add Device](#)

No.	Device Name	Settings	Add Indirect Device
1	PLC1	Series=SRV,Slave Address=1	+

- NOTE**
- Setting value for Wait To Send differs depending on the External Device. Please refer to the manual of the External Device for more details.
 - If you do not set up sufficient Wait To Send time, a communication error may occur.

◆ Device Setting

To display the [Individual Device Settings] dialog box, from [Device-Specific Settings] in the [Device/PLC] window, select the external device and click [Settings] .

To connect multiple External Devices, from [Device-Specific Settings] in the [Device/PLC] window, click [Add Device] to add another External Device.



■ Settings of External Device

Use the address setting switch on the front of the Temperature Controller and the DIP switch inside the Temperature Controller for communication settings of the External Device.

Please refer to the manual of the Temperature Controller for more details.

◆ Procedure

1. Use the address setting switch on the front of the Temperature Controller to set the module address for HOST link.
The number added 1 to the set value becomes the module address.
2. Use the DIP switch inside the Temperature Controller to set the speed and the data bit configuration.

◆ Setting Value

Address setting switch

High digit setting	0
Low digit setting	0

DIP Switch

DIP Switch	Settings	Description
1	ON	Speed
2	OFF	
3	ON	Data bit configuration
4	OFF	
5	OFF	
6	ON	Protocol selection
7	OFF	Fixed
8	OFF	

NOTE • Parameters to be set vary depending on the Temperature Controller. Please refer to the manual of the Temperature Controller for more details.

3.15 Setting Example 15

■ Settings of GP-Pro EX

◆ Communication Settings

To display the setup screen, from the [Project] menu, point to [System Settings] and select [Device/PLC].

Device/PLC 1

Summary [Change Device/PLC](#)

Manufacturer Series Port

Text Data Mode [Change](#)

Communication Settings

SIO Type RS232C RS422/485(2wire) RS422/485(4wire)

Speed

Data Length 7 8

Parity NONE EVEN ODD

Stop Bit 1 2

Flow Control NONE ER(DTR/CTS) XON/XOFF

Timeout (sec)

Retry

Wait To Send (ms)

RI / VCC RI VCC

In the case of RS232C, you can select the 9th pin to RI (Input) or VCC (5V Power Supply). If you use the Digital's RS232C Isolation Unit, please select it to VCC.

[Default](#)

Device-Specific Settings

Allowable Number of Devices/PLCs 16 [Add Device](#)

No.	Device Name	Settings	Add Indirect Device
1	PLC1	Series=SRX,Slave Address=1	+

NOTE

- Setting value for Wait To Send differs depending on the External Device. Please refer to the manual of the External Device for more details.
- If you do not set up sufficient Wait To Send time, a communication error may occur.

◆ Device Setting

To display the [Individual Device Settings] dialog box, from [Device-Specific Settings] in the [Device/PLC] window, select the external device and click [Settings] .

To connect multiple External Devices, from [Device-Specific Settings] in the [Device/PLC] window, click [Add Device] to add another External Device.



■ Settings of External Device

Use the address setting switch on the front of the Temperature Controller and the DIP switch inside the Temperature Controller for communication settings of the External Device.

Please refer to the manual of the Temperature Controller for more details.

◆ Procedure

1. Use the address setting switch on the front of the Temperature Controller to set the module address for HOST link.
The number added 1 to the set value becomes the module address.
2. Use the DIP switch inside the Temperature Controller to set the speed and the data bit configuration.

◆ Setting Value

Address setting switch

High digit setting	0
Low digit setting	0

DIP Switch

DIP Switch	Settings	Description
1	ON	Speed
2	OFF	
3	ON	Data bit configuration
4	OFF	
5	OFF	
6	ON	Protocol selection
7	OFF	Fixed
8	OFF	Internal data bus Terminal resistance setting

NOTE

- Parameters to be set vary depending on the Temperature Controller. Please refer to the manual of the Temperature Controller for more details.

3.16 Setting Example 16

■ Settings of GP-Pro EX

◆ Communication Settings

To display the setup screen, from the [Project] menu, point to [System Settings] and select [Device/PLC].

Device/PLC 1

Summary [Change Device/PLC](#)

Manufacturer Series Port

Text Data Mode [Change](#)

Communication Settings

SIO Type RS232C RS422/485(2wire) RS422/485(4wire)

Speed

Data Length 7 8

Parity NONE EVEN ODD

Stop Bit 1 2

Flow Control NONE ER(DTR/CTS) XON/XOFF

Timeout (sec)

Retry

Wait To Send (ms)

RI / VCC RI VCC

In the case of RS232C, you can select the 9th pin to RI (Input) or VCC (5V Power Supply). If you use the Digital's RS232C Isolation Unit, please select it to VCC.

[Default](#)

Device-Specific Settings

Allowable Number of Devices/PLCs 16 [Add Device](#)

No.	Device Name	Settings	Add Indirect Device
1	PLC1	Series=SA100,Slave Address=1	+

- NOTE**
- Setting value for Wait To Send differs depending on the External Device. Please refer to the manual of the External Device for more details.
 - If you do not set up sufficient Wait To Send time, a communication error may occur.

◆ Device Setting

To display the [Individual Device Settings] dialog box, from [Device-Specific Settings] in the [Device/PLC] window, select the external device and click [Settings] .

To connect multiple External Devices, from [Device-Specific Settings] in the [Device/PLC] window, click [Add Device] to add another External Device.



■ Settings of External Device

Use the SET key, shift key, down key and up key on the front of the Temperature Controller for communication settings of the External Device.

Please refer to the manual of the Temperature Controller for more details.

◆ Procedure

1. While pressing down the SET key, press the shift key to move from the PV/SV display mode to the communication setting mode.
2. Press the SET key to select the parameter.
3. Press the down/up keys to change the setting.
4. While pressing down the SET key, press the shift key to move from the communication setting mode to the PV/SV display mode.
5. To confirm the setting, restart the Temperature Controller.

◆ Setting Value

Add	1
bPS	960
bIT	8n1

NOTE

- Parameters to be set vary depending on the Temperature Controller. Please refer to the manual of the Temperature Controller for more details.

3.17 Setting Example 17

■ Settings of GP-Pro EX

◆ Communication Settings

To display the setup screen, from the [Project] menu, point to [System Settings] and select [Device/PLC].

Device/PLC 1

Summary [Change Device/PLC](#)

Manufacturer Series Port

Text Data Mode [Change](#)

Communication Settings

SIO Type RS232C RS422/485(2wire) RS422/485(4wire)

Speed

Data Length 7 8

Parity NONE EVEN ODD

Stop Bit 1 2

Flow Control NONE ER(DTR/CTS) XON/XOFF

Timeout (sec)

Retry

Wait To Send (ms)

RI / VCC RI VCC

In the case of RS232C, you can select the 9th pin to RI (Input) or VCC (5V Power Supply). If you use the Digital's RS232C Isolation Unit, please select it to VCC.

[Default](#)

Device-Specific Settings

Allowable Number of Devices/PLCs 16 [Add Device](#)

No.	Device Name	Settings	Add Indirect Device
1	PLC1	Series=SA200,Slave Address=1	+

NOTE

- Setting value for Wait To Send differs depending on the External Device. Please refer to the manual of the External Device for more details.
- If you do not set up sufficient Wait To Send time, a communication error may occur.

◆ Device Setting

To display the [Individual Device Settings] dialog box, from [Device-Specific Settings] in the [Device/PLC] window, select the external device and click [Settings] .

To connect multiple External Devices, from [Device-Specific Settings] in the [Device/PLC] window, click [Add Device] to add another External Device.



■ Settings of External Device

Use the SET key, shift key, down key and up key on the front of the Temperature Controller for communication settings of the External Device.

Please refer to the manual of the Temperature Controller for more details.

◆ Procedure

1. While pressing down the SET key, press the shift key to move from the PV/SV display mode to the communication setting mode.
2. Press the SET key to select the parameter.
3. Press the down/up keys to change the setting.
4. While pressing down the SET key, press the shift key to move from the communication setting mode to the PV/SV display mode.
5. To confirm the setting, restart the Temperature Controller.

◆ Setting Value

Add	1
bPS	960
bIT	8n1

NOTE • Parameters to be set vary depending on the Temperature Controller. Please refer to the manual of the Temperature Controller for more details.

3.18 Setting Example 18

■ Settings of GP-Pro EX

◆ Communication Settings

To display the setup screen, from the [Project] menu, point to [System Settings] and select [Device/PLC].

Device/PLC 1

Summary [Change Device/PLC](#)

Manufacturer Series Port

Text Data Mode [Change](#)

Communication Settings

SIO Type RS232C RS422/485(2wire) RS422/485(4wire)

Speed

Data Length 7 8

Parity NONE EVEN ODD

Stop Bit 1 2

Flow Control NONE ER(DTR/CTS) XON/XOFF

Timeout (sec)

Retry

Wait To Send (ms)

RI / VCC RI VCC

In the case of RS232C, you can select the 9th pin to RI (Input) or VCC (5V Power Supply). If you use the Digital's RS232C Isolation Unit, please select it to VCC.

[Default](#)

Device-Specific Settings

Allowable Number of Devices/PLCs 16 [Add Device](#)

No.	Device Name	Settings	Add Indirect Device
1	PLC1	Series=SRMiniHG(H-PCP-A),Slave Address=1	+

NOTE

- Setting value for Wait To Send differs depending on the External Device. Please refer to the manual of the External Device for more details.
- If you do not set up sufficient Wait To Send time, a communication error may occur.

◆ Device Setting

To display the [Individual Device Settings] dialog box, from [Device-Specific Settings] in the [Device/PLC] window, select the external device and click [Settings] .

To connect multiple External Devices, from [Device-Specific Settings] in the [Device/PLC] window, click [Add Device] to add another External Device.

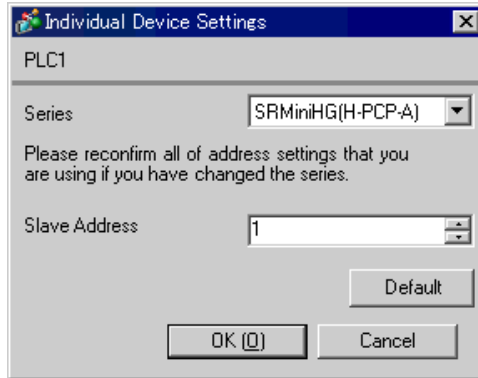

■ Settings of External Device

Use the slave address setting switch on the front of the Temperature Controller and the DIP switch inside the Temperature Controller for communication settings of the External Device.

Please refer to the manual of the Temperature Controller for more details.

◆ Procedure

1. Use the slave address setting switch on the front of the Temperature Controller to set the slave address for HOST link.
The number added 1 to the set value becomes the slave address.
2. Remove the Temperature Controller from the mother block, and use the DIP switch inside the Temperature Controller to set the speed and the data configuration.

◆ Setting Value

Slave address setting switch

High digit setting	0
Low digit setting	0

DIP Switch

DIP Switch	Settings	Description
1	ON	Data configuration
2	ON	
3	ON	Speed
4	OFF	

NOTE • Parameters to be set vary depending on the Temperature Controller. Please refer to the manual of the Temperature Controller for more details.

3.19 Setting Example 19

■ Settings of GP-Pro EX

◆ Communication Settings

To display the setup screen, from the [Project] menu, point to [System Settings] and select [Device/PLC].

Device/PLC 1

Summary [Change Device/PLC](#)

Manufacturer Series Port

Text Data Mode [Change](#)

Communication Settings

SIO Type RS232C RS422/485(2wire) RS422/485(4wire)

Speed

Data Length 7 8

Parity NONE EVEN ODD

Stop Bit 1 2

Flow Control NONE ER(DTR/CTS) XON/XOFF

Timeout (sec)

Retry

Wait To Send (ms)

RI / VCC RI VCC

In the case of RS232C, you can select the 9th pin to RI (Input) or VCC (5V Power Supply). If you use the Digital's RS232C Isolation Unit, please select it to VCC.

[Default](#)

Device-Specific Settings

Allowable Number of Devices/PLCs 16 [Add Device](#)

No.	Device Name	Settings	Add Indirect Device
1	PLC1	Series=SRMiniHG(H-PCP-A),Slave Address=1	+

NOTE

- Setting value for Wait To Send differs depending on the External Device. Please refer to the manual of the External Device for more details.
- If you do not set up sufficient Wait To Send time, a communication error may occur.

◆ Device Setting

To display the [Individual Device Settings] dialog box, from [Device-Specific Settings] in the [Device/PLC] window, select the external device and click [Settings] .

To connect multiple External Devices, from [Device-Specific Settings] in the [Device/PLC] window, click [Add Device] to add another External Device.



■ Settings of External Device

Use the slave address setting switch on the front of the Temperature Controller and the DIP switch inside the Temperature Controller for communication settings of the External Device.

Please refer to the manual of the Temperature Controller for more details.

◆ Procedure

1. Use the slave address setting switch on the front of the Temperature Controller to set the slave address for HOST link.
The number added 1 to the set value becomes the slave address.
2. Remove the Temperature Controller from the mother block, and use the DIP switch inside the Temperature Controller to set the speed and the data configuration.

◆ Setting Value

Slave address setting switch

High digit setting	0
Low digit setting	0

DIP Switch

DIP Switch	Settings	Description
1	ON	Data configuration
2	ON	
3	ON	Speed
4	OFF	

NOTE • Parameters to be set vary depending on the Temperature Controller. Please refer to the manual of the Temperature Controller for more details.

3.20 Setting Example 20

■ Settings of GP-Pro EX

◆ Communication Settings

To display the setup screen, from the [Project] menu, point to [System Settings] and select [Device/PLC].

Device/PLC 1

Summary [Change Device/PLC](#)

Manufacturer Series Port

Text Data Mode [Change](#)

Communication Settings

SIO Type RS232C RS422/485(2wire) RS422/485(4wire)

Speed

Data Length 7 8

Parity NONE EVEN ODD

Stop Bit 1 2

Flow Control NONE ER(DTR/CTS) XON/XOFF

Timeout (sec)

Retry

Wait To Send (ms)

RI / VCC RI VCC

In the case of RS232C, you can select the 9th pin to RI (Input) or VCC (5V Power Supply). If you use the Digital's RS232C Isolation Unit, please select it to VCC.

[Default](#)

Device-Specific Settings

Allowable Number of Devices/PLCs 16 [Add Device](#)

No.	Device Name	Settings	Add Indirect Device
1	PLC1	Series=SRMiniHG(H-PCP-J),Slave Address=1	+

- NOTE**
- Setting value for Wait To Send differs depending on the External Device. Please refer to the manual of the External Device for more details.
 - If you do not set up sufficient Wait To Send time, a communication error may occur.

◆ Device Setting

To display the [Individual Device Settings] dialog box, from [Device-Specific Settings] in the [Device/PLC] window, select the external device and click [Settings] .

To connect multiple External Devices, from [Device-Specific Settings] in the [Device/PLC] window, click [Add Device] to add another External Device.



■ Settings of External Device

Use the unit address setting switch on the front of the Temperature Controller and the DIP switch on the side of the Temperature Controller for communication settings of the External Device.

Please refer to the manual of the Temperature Controller for more details.

◆ Procedure

1. Use the unit address setting switch on the front of the Temperature Controller to set the module address for HOST link.

The number added 1 to the set value becomes the unit address.

2. Use the DIP switch on the side of the Temperature Controller to set the speed and the data configuration.

◆ Setting Value

Unit address setting switch

High digit setting	0
Low digit setting	0

DIP Switch

COM.PORT1/COM.PORT2 setting switch

SW2	Settings	Description
1	OFF	Data bit configuration
2	OFF	
3	OFF	Speed
4	OFF	
5	ON	Communication Protocol
6	OFF	
7	OFF	
8	OFF	

COM.PORT3 setting switch

SW3	Settings	Description
1	OFF	Data bit configuration
2	OFF	
3	OFF	Speed
4	OFF	
5	ON	Communication Protocol
6	OFF	Initialization
7	OFF	MODBUS mode selection
8	OFF	Fixed

-
- NOTE** • Parameters to be set vary depending on the Temperature Controller. Please refer to the manual of the Temperature Controller for more details.
-

3.21 Setting Example 21

■ Settings of GP-Pro EX

◆ Communication Settings

To display the setup screen, from the [Project] menu, point to [System Settings] and select [Device/PLC].

Device/PLC 1

Summary [Change Device/PLC](#)

Manufacturer Series Port

Text Data Mode [Change](#)

Communication Settings

SIO Type RS232C RS422/485(2wire) RS422/485(4wire)

Speed

Data Length 7 8

Parity NONE EVEN ODD

Stop Bit 1 2

Flow Control NONE ER(DTR/CTS) XON/XOFF

Timeout (sec)

Retry

Wait To Send (ms)

RI / VCC RI VCC

In the case of RS232C, you can select the 9th pin to RI (Input) or VCC (5V Power Supply). If you use the Digital's RS232C Isolation Unit, please select it to VCC.

[Default](#)

Device-Specific Settings

Allowable Number of Devices/PLCs [Add Device](#)

No.	Device Name	Settings	Add Indirect Device
1	PLC1	Series=SRMiniHG(H-PCP-J),Slave Address=1	+

- NOTE**
- Setting value for Wait To Send differs depending on the External Device. Please refer to the manual of the External Device for more details.
 - If you do not set up sufficient Wait To Send time, a communication error may occur.

◆ Device Setting

To display the [Individual Device Settings] dialog box, from [Device-Specific Settings] in the [Device/PLC] window, select the external device and click [Settings] .

To connect multiple External Devices, from [Device-Specific Settings] in the [Device/PLC] window, click [Add Device] to add another External Device.



■ Settings of External Device

Use the unit address setting switch on the front of the Temperature Controller and the DIP switch on the side of the Temperature Controller for communication settings of the External Device.

Please refer to the manual of the Temperature Controller for more details.

◆ Procedure

1. Use the unit address setting switch on the front of the Temperature Controller to set the module address for HOST link.
The number added 1 to the set value becomes the unit address.
2. Use the DIP switch on the side of the Temperature Controller to set the speed and the data configuration.

◆ Setting Value

Unit address setting switch

High digit setting	0
Low digit setting	0

DIP Switch

- COM.PORT1/COM.PORT2setting switch

SW2	Settings	Description
1	OFF	Data bit configuration
2	OFF	
3	OFF	Speed
4	OFF	
5	ON	Communication Protocol
6	OFF	
7	OFF	
8	OFF	

- COM.PORT3 setting switch

SW3	Settings	Description
1	OFF	Data bit configuration
2	OFF	
3	OFF	Speed
4	OFF	
5	ON	Communication Protocol
6	OFF	Initialization
7	OFF	MODBUS mode selection
8	OFF	Fixed

NOTE

- Parameters to be set vary depending on the Temperature Controller. Please refer to the manual of the Temperature Controller for more details.

3.22 Setting Example 22

■ Settings of GP-Pro EX

◆ Communication Settings

To display the setup screen, from the [Project] menu, point to [System Settings] and select [Device/PLC].

Device/PLC 1

Summary [Change Device/PLC](#)

Manufacturer Series Port

Text Data Mode [Change](#)

Communication Settings

SIO Type RS232C RS422/485(2wire) RS422/485(4wire)

Speed

Data Length 7 8

Parity NONE EVEN ODD

Stop Bit 1 2

Flow Control NONE ER(DTR/CTS) XON/XOFF

Timeout (sec)

Retry

Wait To Send (ms)

RI / VCC RI VCC

In the case of RS232C, you can select the 9th pin to RI (Input) or VCC (5V Power Supply). If you use the Digital's RS232C Isolation Unit, please select it to VCC.

[Default](#)

Device-Specific Settings

Allowable Number of Devices/PLCs 16 [Add Device](#)

No.	Device Name	Settings	Add Indirect Device
1	PLC1	Series=SRMiniHG(H-PCP-J),Slave Address=1	+

- NOTE**
- Setting value for Wait To Send differs depending on the External Device. Please refer to the manual of the External Device for more details.
 - If you do not set up sufficient Wait To Send time, a communication error may occur.

◆ Device Setting

To display the [Individual Device Settings] dialog box, from [Device-Specific Settings] in the [Device/PLC] window, select the external device and click [Settings] .

To connect multiple External Devices, from [Device-Specific Settings] in the [Device/PLC] window, click [Add Device] to add another External Device.



■ Settings of External Device

Use the unit address setting switch on the front of the Temperature Controller and the DIP switch on the side of the Temperature Controller for communication settings of the External Device.

Please refer to the manual of the Temperature Controller for more details.

◆ Procedure

1. Use the unit address setting switch on the front of the Temperature Controller to set the module address for HOST link.
The number added 1 to the set value becomes the unit address.
2. Use the DIP switch on the side of the Temperature Controller to set the speed and the data configuration.

◆ Setting Value

Unit address setting switch

High digit setting	0
Low digit setting	0

DIP Switch

- COM.PORT3 setting switch

SW3	Settings	Description
1	OFF	Data bit configuration
2	OFF	
3	OFF	Speed
4	OFF	
5	ON	Communication Protocol
6	OFF	Initialization
7	OFF	MODBUS mode selection
8	OFF	Fixed

NOTE

- Parameters to be set vary depending on the Temperature Controller. Please refer to the manual of the Temperature Controller for more details.
-

3.23 Setting Example 23

■ Settings of GP-Pro EX

◆ Communication Settings

To display the setup screen, from the [Project] menu, point to [System Settings] and select [Device/PLC].

Device/PLC 1 [Change Device/PLC](#)

Summary

Manufacturer Series Port

Text Data Mode [Change](#)

Communication Settings

SIO Type RS232C RS422/485(2wire) RS422/485(4wire)

Speed

Data Length 7 8

Parity NONE EVEN ODD

Stop Bit 1 2

Flow Control NONE ER(DTR/CTS) XON/XOFF

Timeout (sec)

Retry

Wait To Send (ms)

RI / VCC RI VCC

In the case of RS232C, you can select the 9th pin to RI (Input) or VCC (5V Power Supply). If you use the Digital's RS232C Isolation Unit, please select it to VCC.

Device-Specific Settings

Allowable Number of Devices/PLCs: 16 [Add Device](#)

No.	Device Name	Settings	Add Indirect Device
1	<input type="text" value="PLC1"/>	<input type="text" value="Series=SRZ(Z-TIO),Slave Address=1"/>	<input type="button" value="+"/>

- NOTE**
- Setting value for Wait To Send differs depending on the External Device. Please refer to the manual of the External Device for more details.
 - If you do not set up sufficient Wait To Send time, a communication error may occur.

◆ Device Setting

To display the [Individual Device Settings] dialog box, from [Device-Specific Settings] in the [Device/PLC] window, select the external device and click [Settings] .

To connect multiple External Devices, from [Device-Specific Settings] in the [Device/PLC] window, click [Add Device] to add another External Device.



■ Settings of External Device

Use the unit address setting switch on the front of the Temperature Controller and the DIP switch on the side of the Temperature Controller for communication settings of the External Device.

Please refer to the manual of the Temperature Controller for more details.

◆ Procedure

1. Use the unit address setting switch on the front of the Temperature Controller to set the slave address.
The number added 1 to the set value becomes the slave address.
2. Use the DIP switch on the side of the Temperature Controller to set the speed, data bit configuration, and communication protocol.
3. After completing the settings, turn ON the Temperature Controller again.

◆ Setting Value

Unit address setting switch

Slave address setting	0
-----------------------	---

DIP Switch

SW	Settings	Description
1	OFF	Speed: 19200 bps
2	ON	
3	OFF	Data bit configuration: Data length 8 bits, no parity, stop 1 bit
4	OFF	
5	ON	
6	ON	Communication protocol: MODBUS communication
7	OFF	Fixed
8	OFF	Fixed

NOTE • Parameters to be set vary depending on the Temperature Controller. Please refer to the manual of the Temperature Controller for more details.

3.24 Setting Example 24

■ Settings of GP-Pro EX

◆ Communication Settings

To display the setup screen, from the [Project] menu, point to [System Settings] and select [Device/PLC].

Device/PLC 1 [Change Device/PLC](#)

Summary

Manufacturer Series Port

Text Data Mode [Change](#)

Communication Settings

SIO Type RS232C RS422/485(2wire) RS422/485(4wire)

Speed

Data Length 7 8

Parity NONE EVEN ODD

Stop Bit 1 2

Flow Control NONE ER(DTR/CTS) XON/XOFF

Timeout (sec)

Retry

Wait To Send (ms)

RI / VCC RI VCC

In the case of RS232C, you can select the 9th pin to RI (Input) or VCC (5V Power Supply). If you use the Digital's RS232C Isolation Unit, please select it to VCC.

[Default](#)

Device-Specific Settings

Allowable Number of Devices/PLCs [Add Device](#)

No.	Device Name	Settings	Add Indirect Device
1	<input type="text" value="PLC1"/>	<input type="text" value="Series=SRZ(Z-DIO),Slave Address=1"/>	+

NOTE

- Setting value for Wait To Send differs depending on the External Device. Please refer to the manual of the External Device for more details.
- If you do not set up sufficient Wait To Send time, a communication error may occur.

◆ Device Setting

To display the [Individual Device Settings] dialog box, from [Device-Specific Settings] in the [Device/PLC] window, select the external device and click [Settings] .

To connect multiple External Devices, from [Device-Specific Settings] in the [Device/PLC] window, click [Add Device] to add another External Device.



■ Settings of External Device

Use the unit address setting switch on the front of the Temperature Controller and the DIP switch on the side of the Temperature Controller for communication settings of the External Device.

Please refer to the manual of the Temperature Controller for more details.

◆ Procedure

1. Use the unit address setting switch on the front of the Temperature Controller to set the slave address.
The number added 17 to the set value becomes the slave address.
2. Use the DIP switch on the side of the Temperature Controller to set the speed, data bit configuration, and communication protocol.
3. After completing the settings, turn ON the Temperature Controller again.

◆ Setting Value

Unit address setting switch

Slave address setting	0
-----------------------	---

DIP Switch

SW	Settings	Description
1	OFF	Speed: 19200 bps
2	ON	
3	OFF	Data bit configuration: Data length 8 bits, no parity, stop 1 bit
4	OFF	
5	ON	
6	ON	Communication protocol: MODBUS communication
7	OFF	Fixed
8	OFF	Fixed

NOTE • Parameters to be set vary depending on the Temperature Controller. Please refer to the manual of the Temperature Controller for more details.

3.25 Setting Example 25

■ Settings of GP-Pro EX

◆ Communication Settings

To display the setup screen, from the [Project] menu, point to [System Settings] and select [Device/PLC].

Device/PLC 1 [Change Device/PLC](#)

Summary

Manufacturer Series Port

Text Data Mode [Change](#)

Communication Settings

SIO Type RS232C RS422/485(2wire) RS422/485(4wire)

Speed

Data Length 7 8

Parity NONE EVEN ODD

Stop Bit 1 2

Flow Control NONE ER(DTR/CTS) XON/XOFF

Timeout (sec)

Retry

Wait To Send (ms)

RI / VCC RI VCC

In the case of RS232C, you can select the 9th pin to RI (Input) or VCC (5V Power Supply). If you use the Digital's RS232C Isolation Unit, please select it to VCC.

[Default](#)

Device-Specific Settings

Allowable Number of Devices/PLCs 16 [Add Device](#)

No.	Device Name	Settings	Add Indirect Device
1	PLC1	Series=SRZ(Z-CT),Slave Address=1	+

NOTE

- Setting value for Wait To Send differs depending on the External Device. Please refer to the manual of the External Device for more details.
- If you do not set up sufficient Wait To Send time, a communication error may occur.

◆ Device Setting

To display the [Individual Device Settings] dialog box, from [Device-Specific Settings] in the [Device/PLC] window, select the external device and click [Settings] .

To connect multiple External Devices, from [Device-Specific Settings] in the [Device/PLC] window, click [Add Device] to add another External Device.



■ Settings of External Device

Use the unit address setting switch on the front of the Temperature Controller and the DIP switch on the side of the Temperature Controller for communication settings of the External Device.

Please refer to the manual of the Temperature Controller for more details.

◆ Procedure

1. Use the unit address setting switch on the front of the Temperature Controller to set the slave address.
The number added 33 to the set value becomes the slave address.
2. Use the DIP switch on the side of the Temperature Controller to set the speed, data bit configuration, and communication protocol.
3. After completing the settings, turn ON the Temperature Controller again.

◆ Setting Value

Unit address setting switch

Slave address setting	0
-----------------------	---

DIP Switch

SW	Settings	Description
1	OFF	Speed: 19200 bps
2	ON	
3	OFF	Data bit configuration: Data length 8 bits, no parity, stop 1 bit
4	OFF	
5	ON	
6	ON	Communication protocol: MODBUS communication
7	OFF	Fixed
8	OFF	Fixed

NOTE • Parameters to be set vary depending on the Temperature Controller. Please refer to the manual of the Temperature Controller for more details.

3.26 Setting Example 26

■ Settings of GP-Pro EX

◆ Communication Settings

To display the setup screen, from the [Project] menu, point to [System Settings] and select [Device/PLC].

Device/PLC 1 [Change Device/PLC](#)

Summary
 Manufacturer Series Port

Text Data Mode [Change](#)

Communication Settings

SIO Type RS232C RS422/485(2wire) RS422/485(4wire)

Speed

Data Length 7 8

Parity NONE EVEN ODD

Stop Bit 1 2

Flow Control NONE ER(DTR/CTS) XON/XOFF

Timeout (sec)

Retry

Wait To Send (ms)

RI / VCC RI VCC
 In the case of RS232C, you can select the 9th pin to RI (Input) or VCC (5V Power Supply). If you use the Digital's RS232C Isolation Unit, please select it to VCC.

Device-Specific Settings

Allowable Number of Devices/PLCs 16 [Add Device](#)

No.	Device Name	Settings	Add Indirect Device
1	PLC1	Series=SRZ(Z-COM),Slave Address=1	<input type="button" value="+"/>

NOTE

- Setting value for Wait To Send differs depending on the External Device. Please refer to the manual of the External Device for more details.
- If you do not set up sufficient Wait To Send time, a communication error may occur.

◆ Device Setting

To display the [Individual Device Settings] dialog box, from [Device-Specific Settings] in the [Device/PLC] window, select the external device and click [Settings] .

To connect multiple External Devices, from [Device-Specific Settings] in the [Device/PLC] window, click [Add Device] to add another External Device.



■ Settings of External Device

Use the unit address setting switch on the front of the Temperature Controller and the DIP switch on the side of the Temperature Controller for communication settings of the External Device.

Please refer to the manual of the Temperature Controller for more details.

◆ Procedure

1. Use the unit address setting switch on the front of the Temperature Controller to set the slave address.
The number added 1 to the set value becomes the slave address.
2. Use the DIP switch on the side of the Temperature Controller to set the speed, data bit configuration, and communication protocol.
3. After completing the settings, turn ON the Temperature Controller again.

◆ Setting Value

Unit address setting switch

Slave address setting	0
-----------------------	---

DIP Switch

SW	Settings	Description
1	OFF	Speed: 19200 bps
2	ON	
3	ON	Communication protocol: Host communication (MODBUS) Data length 8 bits, no parity, stop 1 bit

NOTE • Parameters to be set vary depending on the Temperature Controller. Please refer to the manual of the Temperature Controller for more details.

3.27 Setting Example 27

■ Settings of GP-Pro EX

◆ Communication Settings

To display the setup screen, from the [Project] menu, point to [System Settings] and select [Device/PLC].

Device/PLC 1 [Change Device/PLC](#)

Summary

Manufacturer Series Port

Text Data Mode [Change](#)

Communication Settings

SIO Type RS232C RS422/485(2wire) RS422/485(4wire)

Speed

Data Length 7 8

Parity NONE EVEN ODD

Stop Bit 1 2

Flow Control NONE ER(DTR/CTS) XON/XOFF

Timeout (sec)

Retry

Wait To Send (ms)

RI / VCC RI VCC

In the case of RS232C, you can select the 9th pin to RI (Input) or VCC (5V Power Supply). If you use the Digital's RS232C Isolation Unit, please select it to VCC.

[Default](#)

Device-Specific Settings

Allowable Number of Devices/PLCs [Add Device](#)

No.	Device Name	Settings	Add Indirect Device
1	PLC1	Series=SRZ(Z-COM),Slave Address=1	+

- NOTE**
- Setting value for Wait To Send differs depending on the External Device. Please refer to the manual of the External Device for more details.
 - If you do not set up sufficient Wait To Send time, a communication error may occur.

◆ Device Setting

To display the [Individual Device Settings] dialog box, from [Device-Specific Settings] in the [Device/PLC] window, select the external device and click [Settings] .

To connect multiple External Devices, from [Device-Specific Settings] in the [Device/PLC] window, click [Add Device] to add another External Device.



■ Settings of External Device

Use the unit address setting switch on the front of the Temperature Controller and the DIP switch on the side of the Temperature Controller for communication settings of the External Device.

Please refer to the manual of the Temperature Controller for more details.

◆ Procedure

1. Use the unit address setting switch on the front of the Temperature Controller to set the slave address.
The number added 1 to the set value becomes the slave address.
2. Use the DIP switch on the side of the Temperature Controller to set the speed, data bit configuration, and communication protocol.
3. After completing the settings, turn ON the Temperature Controller again.

◆ Setting Value

Unit address setting switch

Slave address setting	0
-----------------------	---

DIP Switch

SW	Settings	Description
1	OFF	Speed: 19200 bps
2	ON	
3	ON	Communication protocol: Host communication (MODBUS) Data length 8 bits, no parity, stop 1 bit

NOTE • Parameters to be set vary depending on the Temperature Controller. Please refer to the manual of the Temperature Controller for more details.

3.28 Setting Example 28

■ Settings of GP-Pro EX

◆ Communication Settings

To display the setup screen, from the [Project] menu, point to [System Settings] and select [Device/PLC].

Device/PLC 1 [Change Device/PLC](#)

Summary
 Manufacturer Series Port

Text Data Mode [Change](#)

Communication Settings

SIO Type RS232C RS422/485(2wire) RS422/485(4wire)

Speed

Data Length 7 8

Parity NONE EVEN ODD

Stop Bit 1 2

Flow Control NONE ER(DTR/CTS) XON/XOFF

Timeout (sec)

Retry

Wait To Send (ms)

RI / VCC RI VCC
 In the case of RS232C, you can select the 9th pin to RI (Input) or VCC (5V Power Supply). If you use the Digital's RS232C Isolation Unit, please select it to VCC.

Device-Specific Settings

Allowable Number of Devices/PLCs 16 [Add Device](#)

No.	Device Name	Settings	Add Indirect Device
1	PLC1	Series=SRZ(Z-COM),Slave Address=1	<input type="button" value="+"/>

NOTE

- Setting value for Wait To Send differs depending on the External Device. Please refer to the manual of the External Device for more details.
- If you do not set up sufficient Wait To Send time, a communication error may occur.

◆ Device Setting

To display the [Individual Device Settings] dialog box, from [Device-Specific Settings] in the [Device/PLC] window, select the external device and click [Settings] .

To connect multiple External Devices, from [Device-Specific Settings] in the [Device/PLC] window, click [Add Device] to add another External Device.



■ Settings of External Device

Use the unit address setting switch on the front of the Temperature Controller and the DIP switch on the side of the Temperature Controller for communication settings of the External Device.

Please refer to the manual of the Temperature Controller for more details.

◆ Procedure

1. Use the unit address setting switch on the front of the Temperature Controller to set the slave address.
The number added 1 to the set value becomes the slave address.
2. Use the DIP switch on the side of the Temperature Controller to set the speed, data bit configuration, and communication protocol.
3. After completing the settings, turn ON the Temperature Controller again.

◆ Setting Value

Unit address setting switch

Slave address setting	0
-----------------------	---

DIP Switch

SW	Settings	Description
4	ON	Speed: 19200 bps
5	ON	Communication protocol: Host communication (MODBUS) Data length 8 bits, no parity, stop 1 bit
6	OFF	
7	OFF	
8	OFF	DIP switch setting: Enabled

NOTE • Parameters to be set vary depending on the Temperature Controller. Please refer to the manual of the Temperature Controller for more details.

3.29 Setting Example 29

■ Settings of GP-Pro EX

◆ Communication Settings

To display the setup screen, from the [Project] menu, point to [System Settings] and select [Device/PLC].

Device/PLC 1 [Change Device/PLC](#)

Summary

Manufacturer Series Port

Text Data Mode [Change](#)

Communication Settings

SIO Type RS232C RS422/485(2wire) RS422/485(4wire)

Speed

Data Length 7 8

Parity NONE EVEN ODD

Stop Bit 1 2

Flow Control NONE ER(DTR/CTS) XON/XOFF

Timeout (sec)

Retry

Wait To Send (ms)

RI / VCC RI VCC

In the case of RS232C, you can select the 9th pin to RI (Input) or VCC (5V Power Supply). If you use the Digital's RS232C Isolation Unit, please select it to VCC.

Device-Specific Settings

Allowable Number of Devices/PLCs [Add Device](#)

No.	Device Name	Settings	Add Indirect Device
1	<input type="text" value="PLC1"/>	<input type="text" value="Series=SRZ(Z-COM),Slave Address=1"/>	<input type="button" value="+"/>

- NOTE**
- Setting value for Wait To Send differs depending on the External Device. Please refer to the manual of the External Device for more details.
 - If you do not set up sufficient Wait To Send time, a communication error may occur.

◆ Device Setting

To display the [Individual Device Settings] dialog box, from [Device-Specific Settings] in the [Device/PLC] window, select the external device and click [Settings] .

To connect multiple External Devices, from [Device-Specific Settings] in the [Device/PLC] window, click [Add Device] to add another External Device.



■ Settings of External Device

Use the unit address setting switch on the front of the Temperature Controller and the DIP switch on the side of the Temperature Controller for communication settings of the External Device.

Please refer to the manual of the Temperature Controller for more details.

◆ Procedure

1. Use the unit address setting switch on the front of the Temperature Controller to set the slave address.
The number added 1 to the set value becomes the slave address.
2. Use the DIP switch on the side of the Temperature Controller to set the speed, data bit configuration, and communication protocol.
3. After completing the settings, turn ON the Temperature Controller again.

◆ Setting Value

Unit address setting switch

Slave address setting	0
-----------------------	---

DIP Switch

SW	Settings	Description
4	ON	Speed: 19200 bps
5	ON	Communication protocol: Host communication (MODBUS) Data length 8 bits, no parity, stop 1 bit
6	OFF	
7	OFF	
8	OFF	DIP switch setting: Enabled

NOTE • Parameters to be set vary depending on the Temperature Controller. Please refer to the manual of the Temperature Controller for more details.

4 Setup Items

Set communication settings of the Display with GP-Pro Ex or in offline mode of the Display.

The setting of each parameter must be identical to that of External Device.

 "3 Example of Communication Setting" (page 11)

4.1 Setup Items in GP-Pro EX

■ Communication Settings

To display the setup screen, from the [Project] menu, point to [System Settings] and select [Device/PLC].

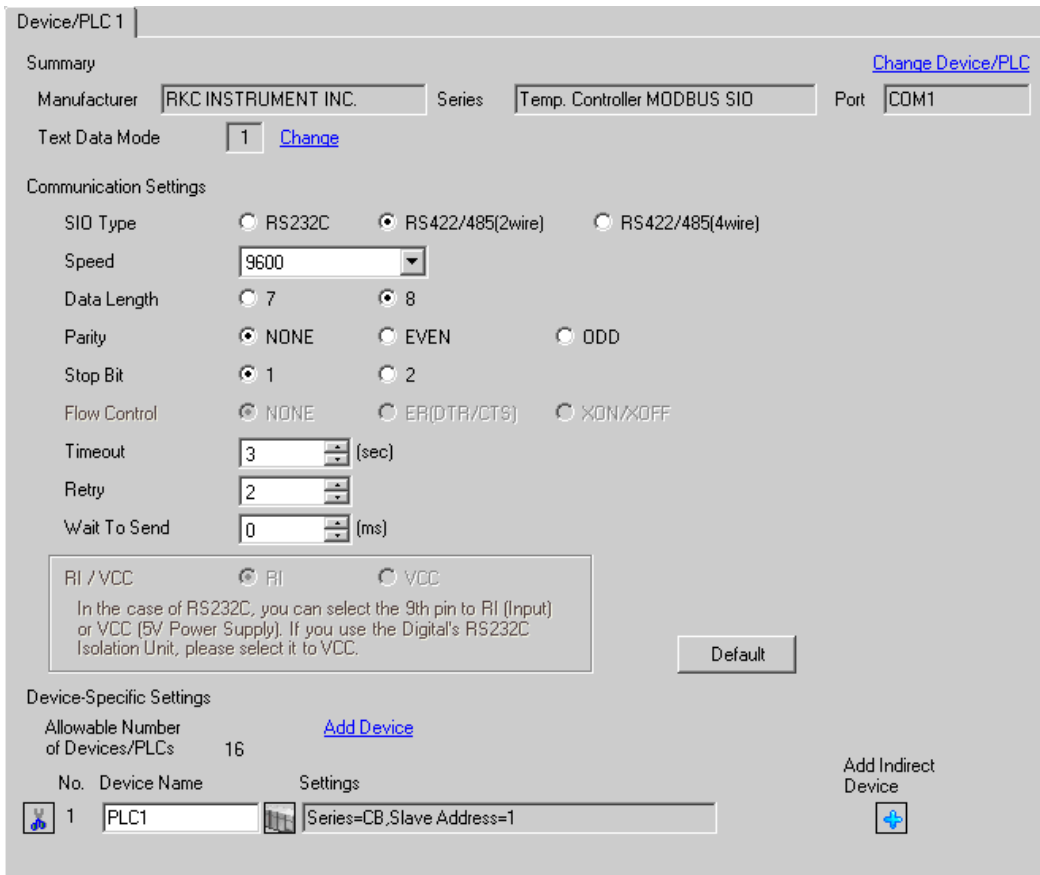

Device/PLC 1

Summary [Change Device/PLC](#)

Manufacturer Series Port

Text Data Mode [Change](#)

Communication Settings

SIO Type RS232C RS422/485(2wire) RS422/485(4wire)

Speed

Data Length 7 8

Parity NONE EVEN ODD

Stop Bit 1 2

Flow Control NONE ER(DTR/CTS) XON/XOFF

Timeout (sec)

Retry

Wait To Send (ms)

RI / VCC RI VCC

In the case of RS232C, you can select the 9th pin to RI (Input) or VCC (5V Power Supply). If you use the Digital's RS232C Isolation Unit, please select it to VCC.

Device-Specific Settings

Allowable Number of Devices/PLCs: 16 [Add Device](#)

No.	Device Name	Settings
 1	<input type="text" value="PLC1"/>	<input type="text" value="Series=CB, Slave Address=1"/>

Setup Items	Setup Description
SIO Type	Select the SIO type to communicate with the External Device.
Speed	Select speed between the External Device and the Display.
Data Length	Select data length.
Parity	Select how to check parity.
Stop Bit	Select stop bit length.
Flow Control	The communication control method to prevent overflow of transmission and reception data is displayed.

Setup Items	Setup Description
Timeout	Use an integer from 1 to 127 to enter the time (s) for which the Display waits for the response from the External Device.
Retry	In case of no response from the External Device, use an integer from 0 to 255 to enter how many times the Display retransmits the command.
Wait To Send	Use an integer from 0 to 255 to enter standby time (ms) for the Display from receiving packets to transmitting next commands.
RI/VCC	Switches RI/VCC of the 9th pin. It is necessary to change RI/5V by changeover switch of IPC when connect with IPC. Please refer to the manual of the IPC for more detail.

NOTE • Refer to the GP-Pro EX Reference Manual for Indirect Device.

Cf. GP-Pro EX Reference Manual "Changing the Device/PLC at Runtime (Indirect Device)"

■ Device Setting

To display the [Individual Device Settings] dialog box, from [Device-Specific Settings] in the [Device/PLC] window, select the external device and click [Settings] .

To connect multiple External Devices, from [Device-Specific Settings] in the [Device/PLC] window, click [Add Device] to add another External Device.



Setup Items	Setup Description
Series	Select a model of the External Device.
Slave Address	Enter the Slave Address of the External Device.

4.2 Setup Items in Offline Mode

- NOTE** • Refer to the Maintenance/Troubleshooting guide for information on how to enter offline mode or about the operation.

Cf. Maintenance/Troubleshooting Guide "Offline Mode"

- The number of the setup items to be displayed for 1 page in the offline mode depends on the Display in use. Please refer to the Reference manual for details.

■ Communication Settings

To display the setting screen, touch [Device/PLC Settings] from [Peripheral Equipment Settings] in the offline mode. Touch the External Device you want to set from the displayed list.

Comm.	Device	Option		
Temp. Controller MODBUS SIO		[COM1]	Page 1/1	
SIO Type	RS422/485(2wire) ▼			
Speed	9600 ▼			
Data Length	<input type="radio"/> 7 <input checked="" type="radio"/> 8			
Parity	<input checked="" type="radio"/> NONE <input type="radio"/> EVEN <input type="radio"/> ODD			
Stop Bit	<input checked="" type="radio"/> 1 <input type="radio"/> 2			
Flow Control	NONE			
Timeout(s)	3 ▼ ▲			
Retry	2 ▼ ▲			
Wait To Send(ms)	0 ▼ ▲			
Exit		Back		2006/01/17 18:06:30

Setup Items	Setup Description
SIO Type	Select the SIO type to communicate with the External Device. IMPORTANT To make the communication settings correctly, confirm the serial interface specifications of Display unit for [SIO Type]. We cannot guarantee the operation if a communication type that the serial interface does not support is specified. For details concerning the serial interface specifications, refer to the manual for Display unit.
Speed	Select speed between the External Device and the Display.
Data Length	Select data length.
Parity	Select how to check parity.
Stop Bit	Select stop bit length.
Flow Control	The communication control method to prevent overflow of transmission and reception data is displayed.

Setup Items	Setup Description
Timeout	Use an integer from 1 to 127 to enter the time (s) for which the Display waits for the response from the External Device.
Retry	In case of no response from the External Device, use an integer from 0 to 255 to enter how many times the Display retransmits the command.
Wait To Send	Use an integer from 0 to 255 to enter standby time (ms) for the Display from receiving packets to transmitting next commands.

■ Device Setting

To display the setting screen, touch [Device/PLC Settings] from [Peripheral Equipment Settings]. Touch the External Device you want to set from the displayed list, and touch [Device Settings].

Comm.	Device	Option		
Temp. Controller MODBUS SIO		[COM1]	Page 1/1	
Device/PLC Name		[PLC1]		
Series		CB		
Slave Address		1		
Exit		Back		2006/01/17 18:06:33

Setup Items	Setup Description
Device name	Select the External Device to set. Device name is a title of the External Device set with GP-Pro EX.(Default [PLC1])
Series	Displays a model of the External Device.
Slave Address	Enter the slave address of the External Device, using 1 to 99.

■ Option

To display the setting screen, touch [Device/PLC Settings] from [Peripheral Settings]. Touch the External Device you want to set from the displayed list, and touch [Option].

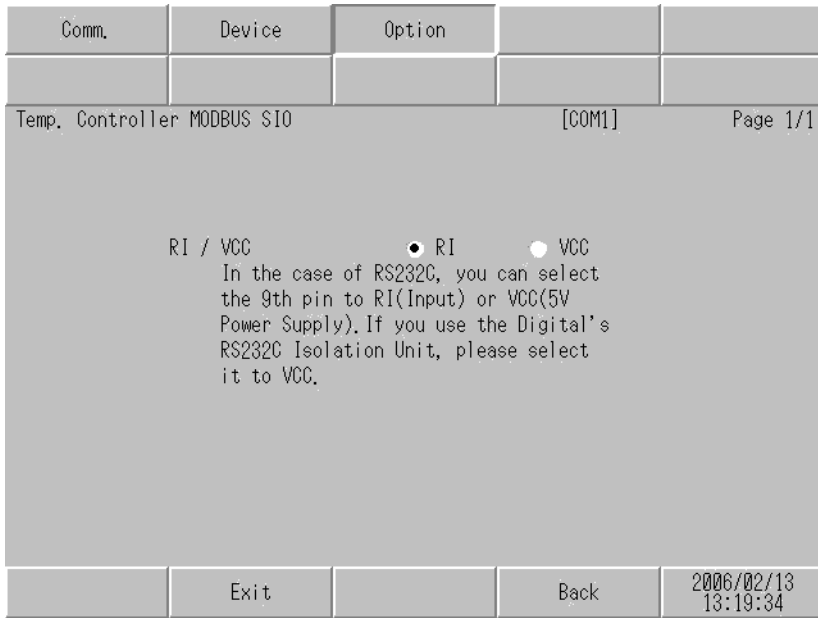

Setup Items	Setup Description
RI/VCC	Switches RI/VCC of the 9th pin. It is necessary to change RI/5V by changeover switch of IPC when connect with IPC. Please refer to the manual of the IPC for more detail.

NOTE

- GP-4100 series, GP-4*01TM, GP-Rear Module, LT-4*01TM and LT-Rear Module do not have the [Option] setting in the offline mode.

5 Cable Diagram

The cable diagram shown below may be different from the cable diagram recommended by RKC INSTRUMENT INC. Please be assured there is no operational problem in applying the cable diagram shown in this manual.

- The FG pin of the main body of the External Device must be D-class grounded. Please refer to the manual of the External Device for more details.
- SG and FG are connected inside the Display. When connecting SG to the External Device, design the system not to form short-circuit loop.
- When using RS422/485 (2 wire) or RS422/485 (4 wire) for connection, you can connect maximum 16 units of Temperature Controller. Note that you can connect maximum 15 units of Temperature Controller when using RS422/485 (4 wire) to connect the FB400/900 Series.
- Connect the isolation unit, when communication is not stabilized under the influence of a noise etc..

Cable Diagram 1

Display (Connection Port)	Cable		Remarks
GP3000 (COM1) GP4000* ¹ (COM1) SP5000* ² (COM1/2) SP-5B00 (COM1) ST3000 (COM1) ST6000 (COM1) STM6000 (COM1) STC6000 (COM1) ET6000 (COM1) LT3000 (COM1) IPC* ³ PC/AT	1A	User-created cable	Cable length: 15m or less
GP-4105 (COM1) GP-4115T (COM1) GP-4115T3 (COM1)	1B	User-created cable	Cable length: 15m or less
LT-4*01TM (COM1) LT-Rear Module (COM1)	1C	RJ45 RS-232C Cable (5m) by Pro-face PFXZLMCBJR21	Cable length: 5m or less

*1 All GP4000 models except GP-4100 Series and GP-4203T

*2 Except SP-5B00

*3 Only the COM port which can communicate by RS-232C can be used.

 ■ IPC COM Port (page 7)

1A)

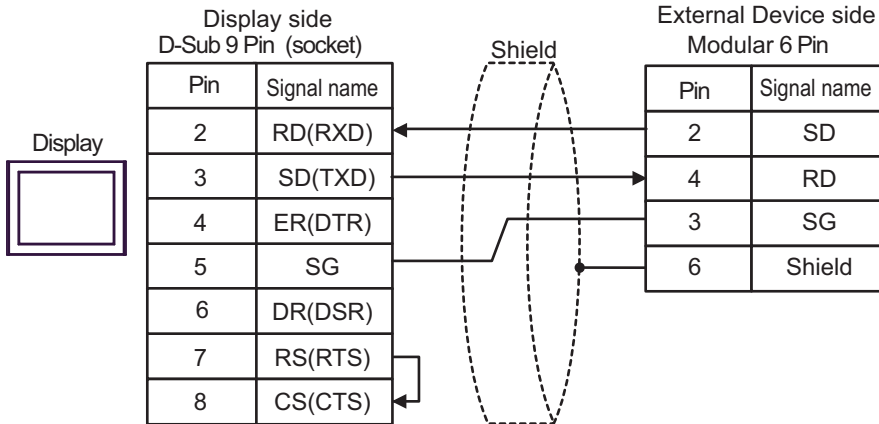

1B)

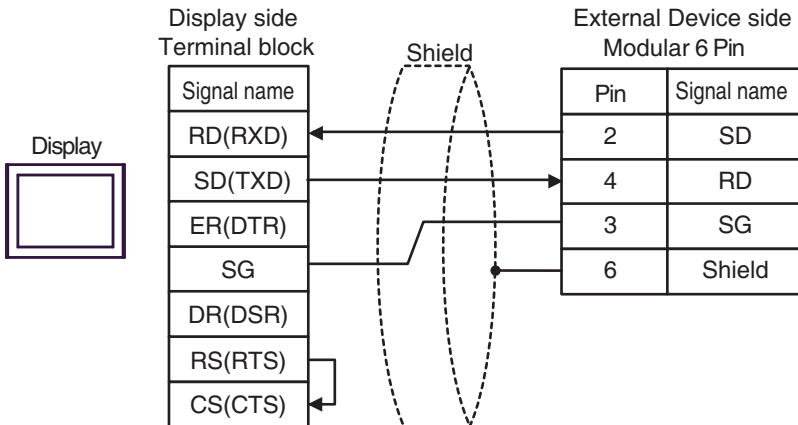

1C)

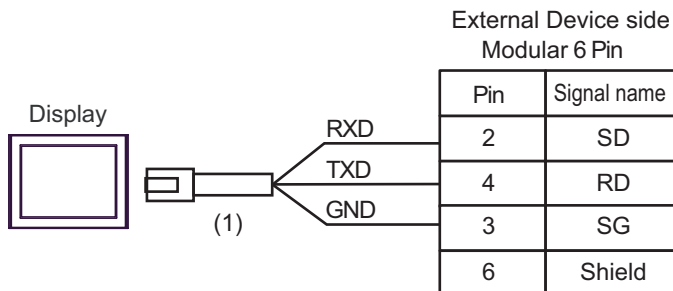

Number	Name	Notes
(1)	RJ45 RS-232C Cable (5m) by Pro-face PFXZLMCBJR21	

Cable Diagram 2

Display (Connection Port)	Cable		Remarks
GP3000* ¹ (COM1) AGP-3302B (COM2) GP-4*01TM (COM1) GP-Rear Module (COM1) ST3000* ² (COM2) LT3000 (COM1) IPC* ³	2A	COM port conversion adapter by Pro-face CA3-ADPCOM-01 + Terminal block conversion adapter by Pro-face CA3-ADPTRM-01 + User-created cable	Cable length: 1200m or less
	2B	User-created cable	
GP3000* ⁴ (COM2)	2C	Online adapter by Pro-face CA4-ADPONL-01 + Terminal block conversion adapter by Pro-face CA3-ADPTRM-01 + User-created cable	Cable length: 1200m or less
	2D	Online adapter by Pro-face CA4-ADPONL-01 + User-created cable	
GP-4106 (COM1) GP-4116T (COM1)	2E	User-created cable	Cable length: 1200m or less
GP4000* ⁵ (COM2) GP-4201T (COM1) SP5000* ⁶ (COM1/2) SP-5B00 (COM2) ST6000* ⁷ (COM2) ST-6200 (COM1) STM6000 (COM1) STC6000 (COM1) ET6000* ⁸ (COM2) PS6000 (Basic Box) (COM1/2)	2F	RS-422 terminal block conversion adapter by Pro-face PFXZCBADTM1* ⁹ + User-created cable	Cable length: 1200m or less
	2B	User-created cable	
PE-4000B* ¹⁰ PS5000* ¹⁰ PS6000 (Optional Interface)* ¹⁰	2G	User-created cable	Cable length: 1200m or less

*1 All GP3000 models except AGP-3302B

*2 Except AST-3211A and AST-3302B

*3 Only the COM port which can communicate by RS-422/485 (4 wire) can be used. (Except PE-4000B, PS5000, and PS6000)

 ■ IPC COM Port (page 7)

*4 All GP3000 models except GP-3200 series and AGP-3302B

*5 All GP4000 models except GP-4100 series, GP-4*01TM, GP-Rear Module, GP-4201T and GP-4*03T

*6 Except SP-5B00

*7 Except ST-6200

- *8 Due to the COM port specifications, flow control is not possible. Omit wiring the control pins on the Display side of the cable diagram.
- *9 When using a Terminal Block Conversion Adapter (CA3-ADPTRM-01) instead of the RS-422 Terminal Block Conversion Adapter, refer to Cable Diagram 2A.
- *10 Only the COM port which can communicate by RS-422/485 (4 wire) can be used.
 - ☞ ■ IPC COM Port (page 7)

2A)

- 1:1 Connection

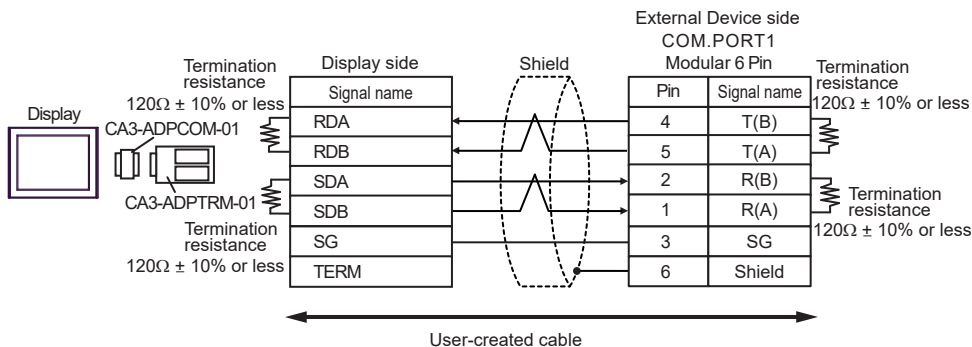

- 1:n connection

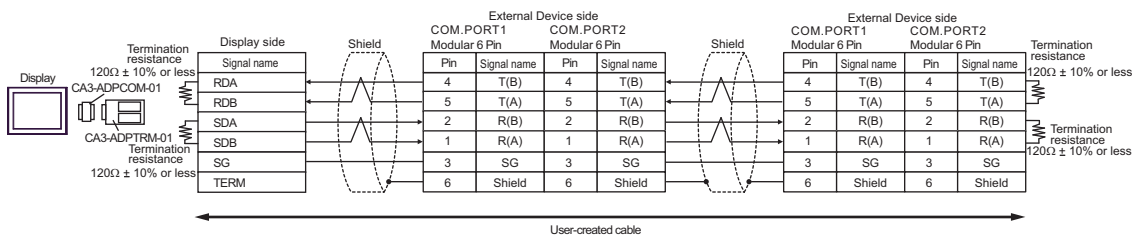

2B)

- 1:1 Connection

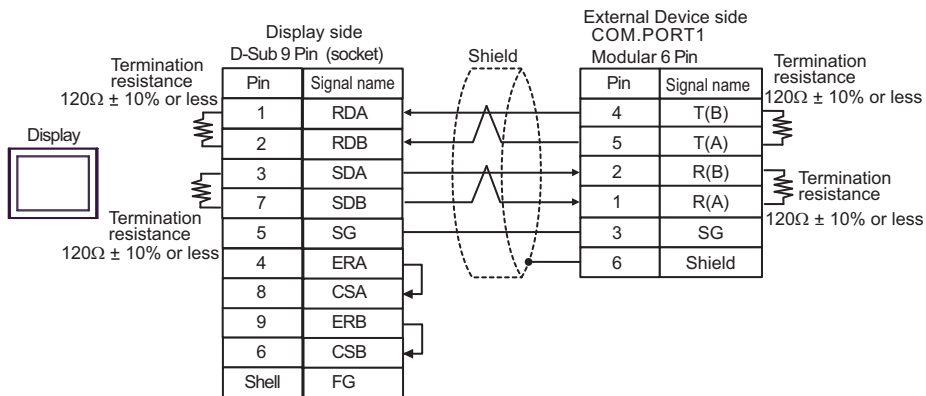

- 1:n Connection

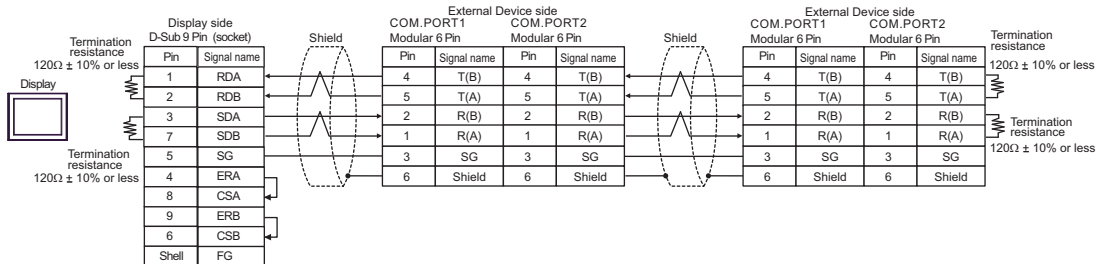

2C)

- 1:1 Connection

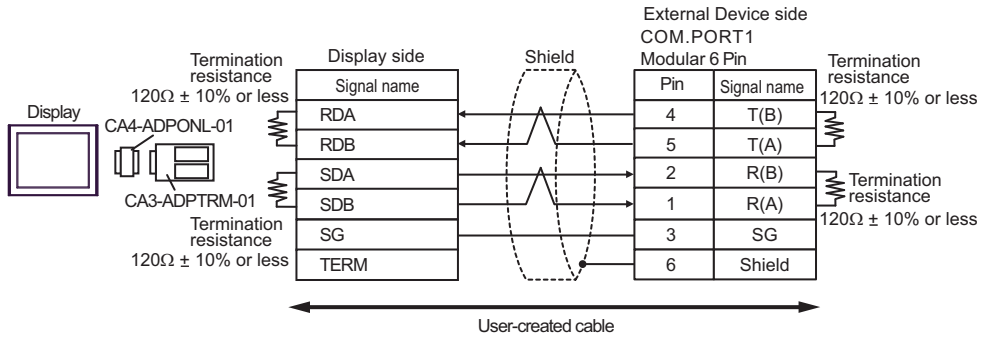

- 1:n Connection

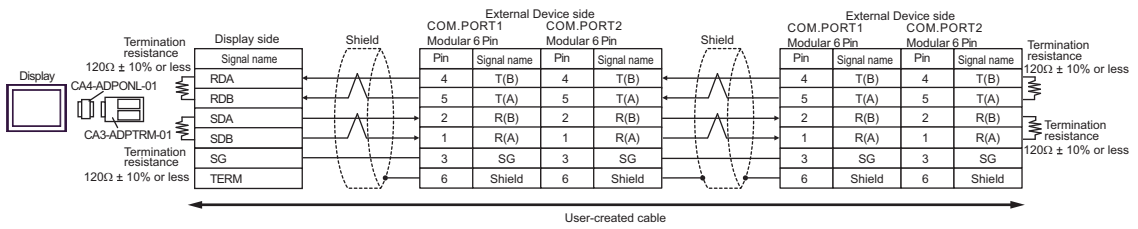

2D)

- 1:1 Connection

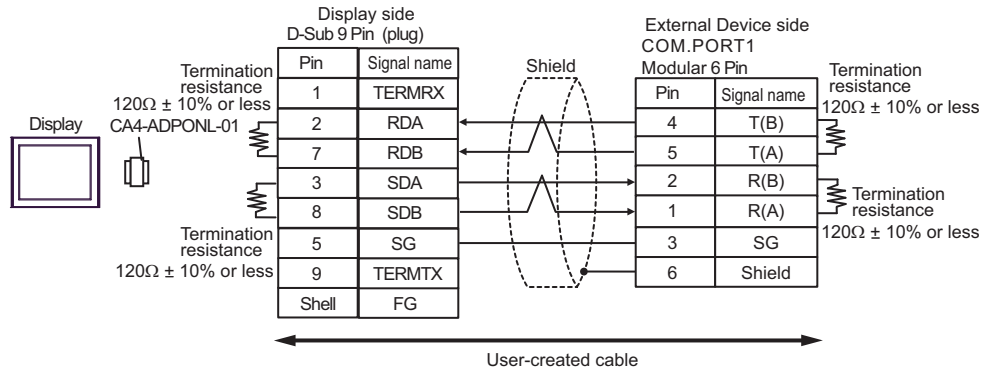

- 1:n Connection

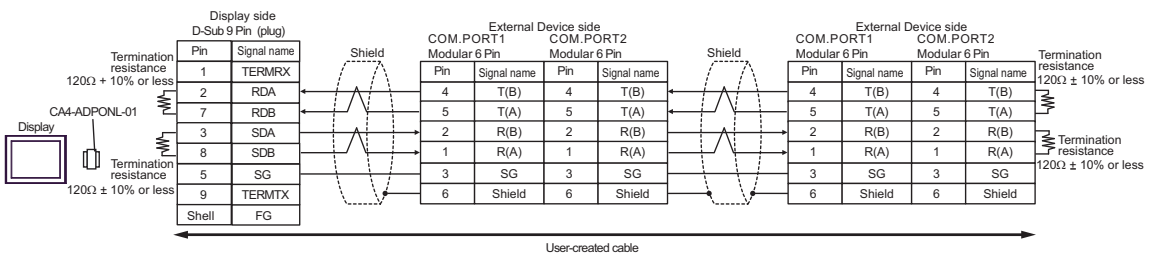

2E)

- 1:1 Connection

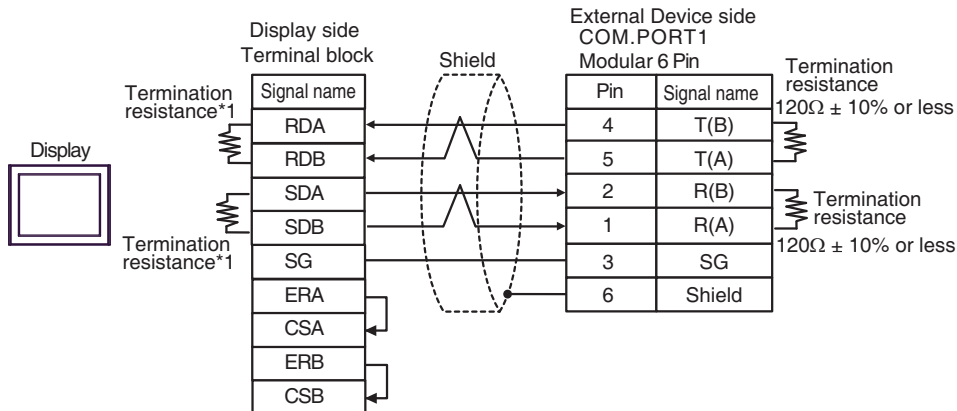

- 1:n Connection

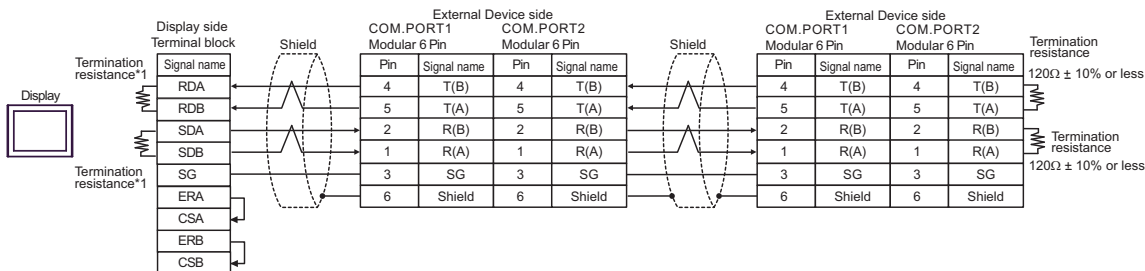

*1 The resistance in the Display is used as the termination resistance. Set the value of the DIP Switch on the rear of the Display as shown in the table below.

DIP Switch No.	Set Value
1	ON
2	ON
3	ON
4	ON

2F)

- 1:1 Connection

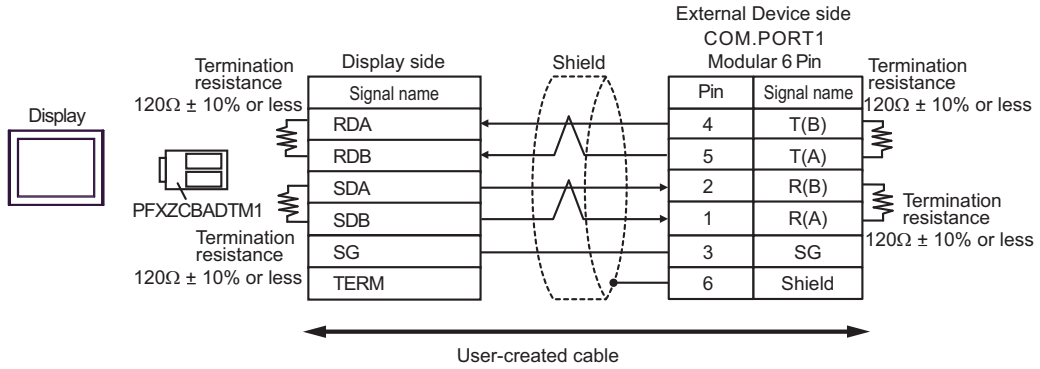

- 1:n connection

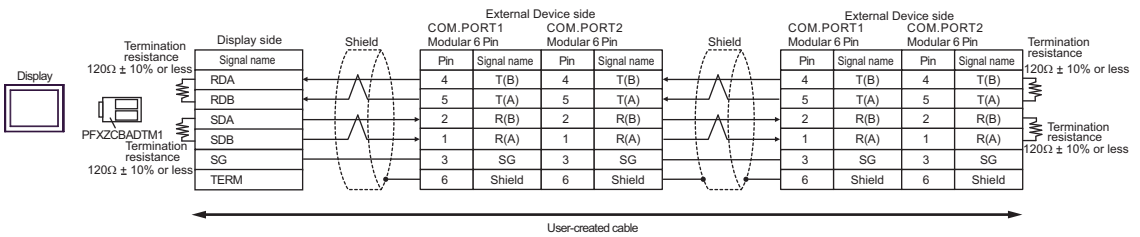

2G)

- 1:1 Connection

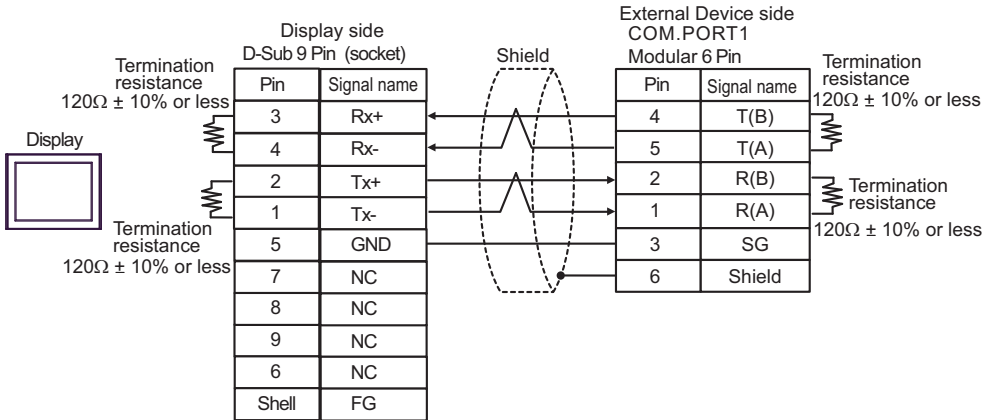

- 1:n Connection

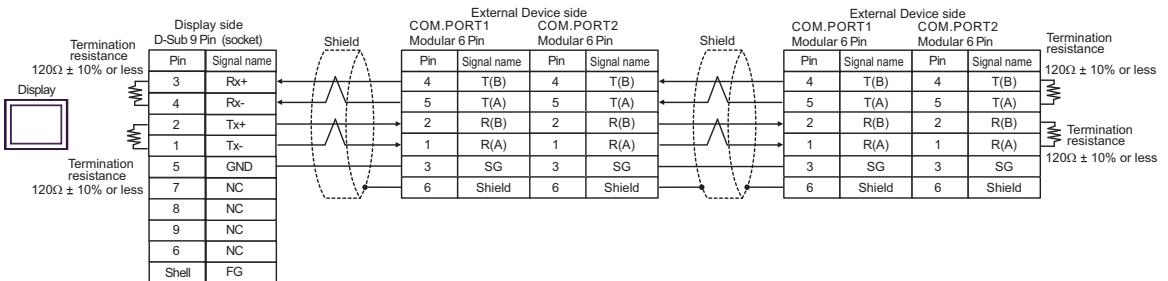

Cable Diagram 3

Display (Connection Port)	Cable		Remarks
GP3000* ¹ (COM1) AGP-3302B (COM2) GP-4*01TM (COM1) GP-Rear Module (COM1) ST3000* ² (COM2) LT3000 (COM1)	3A	COM port conversion adapter by Pro-face CA3-ADPCOM-01 + Terminal block conversion adapter by Pro-face CA3-ADPTRM-01 + User-created cable	Cable length: 1200m or less
	3B	User-created cable	
GP3000* ³ (COM2)	3C	Online adapter by Pro-face CA4-ADPONL-01 + Terminal block conversion adapter by Pro-face CA3-ADPTRM-01 + User-created cable	Cable length: 1200m or less
	3D	Online adapter by Pro-face CA4-ADPONL-01 + User-created cable	
IPC* ⁴	3E	COM port conversion adapter by Pro-face CA3-ADPCOM-01 + Terminal block conversion adapter by Pro-face CA3-ADPTRM-01 + User-created cable	Cable length: 1200m or less
	3F	User-created cable	
GP-4106 (COM1) GP-4116T (COM1)	3G	User-created cable	Cable length: 1200m or less
GP-4107 (COM1) GP-4*03T* ⁵ (COM2) GP-4203T (COM1)	3H	User-created cable	Cable length: 1200m or less
GP4000* ⁶ (COM2) GP-4201T (COM1) SP5000* ⁷ (COM1/2) SP-5B00 (COM2) ST6000* ⁸ (COM2) ST-6200 (COM1) STM6000 (COM1) STC6000 (COM1) ET6000* ⁹ (COM2) PS6000 (Basic Box) (COM1/2)	3I	RS-422 terminal block conversion adapter by Pro-face PFXZCBADTM1* ¹⁰ + User-created cable	Cable length: 1200m or less
	3B	User-created cable	
LT-4*01TM (COM1) LT-Rear Module (COM1)	3J	RJ45 RS-485 Cable (5m) by Pro-face PFXZLMCBJR81	Cable length: 200m or less
PE-4000B* ¹¹ PS5000* ¹¹ PS6000 (Optional Interface)* ¹¹	3K	User-created cable	Cable length: 1200m or less

*1 All GP3000 models except AGP-3302B

- *2 Except AST-3211A and AST-3302B
- *3 All GP3000 models except GP-3200 series and AGP-3302B
- *4 Only the COM port which can communicate by RS-422/485 (2 wire) can be used. (Except PE-4000B, PS5000, and PS6000)
 - ☞ ■ IPC COM Port (page 7)
- *5 Except GP-4203T
- *6 All GP4000 models except GP-4100 series, GP-4*01TM, GP-Rear Module, GP-4201T and GP-4*03T
- *7 Except SP-5B00
- *8 Except ST-6200
- *9 Due to the COM port specifications, flow control is not possible. Omit wiring the control pins on the Display side of the cable diagram.
- *10 When using a Terminal Block Conversion Adapter (CA3-ADPTRM-01) instead of the RS-422 Terminal Block Conversion Adapter, refer to Cable Diagram 3A.
- *11 Only the COM port which can communicate by RS-422/485 (2 wire) can be used.
 - ☞ ■ IPC COM Port (page 7)

3A)

- 1:1 Connection

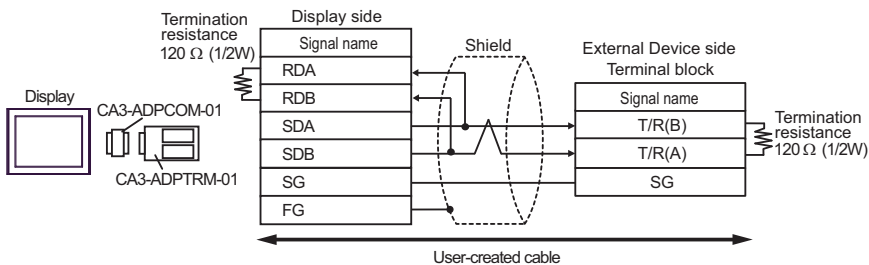

- 1:n connection

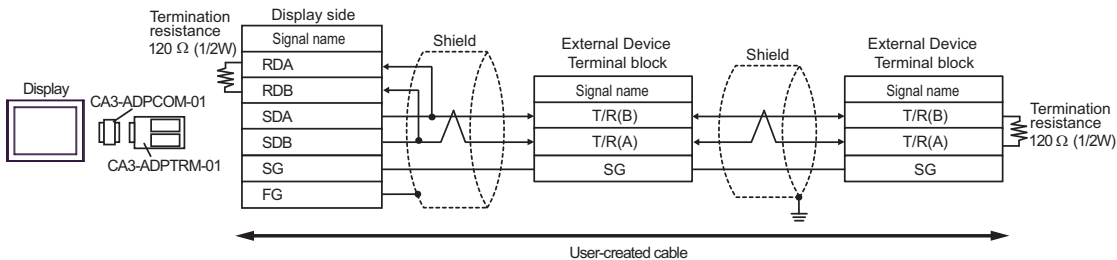

3B)

- 1:1 Connection

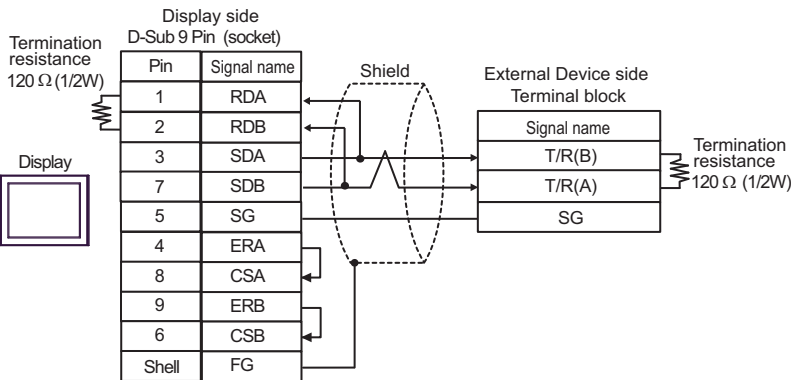

- 1:n Connection

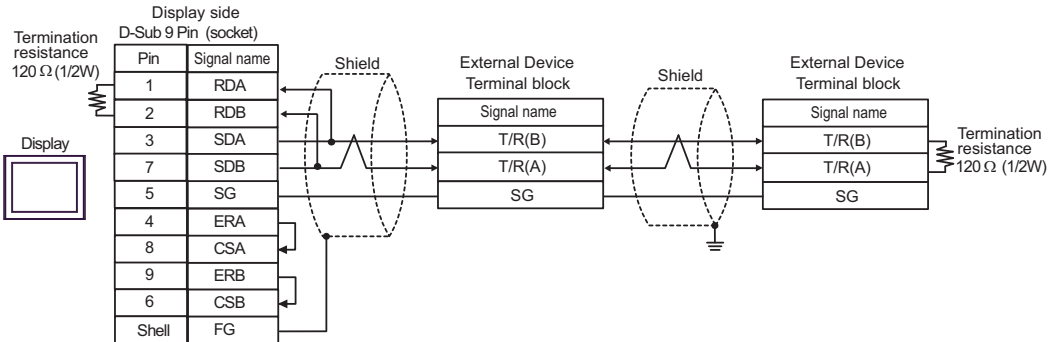

3C)

- 1:1 Connection

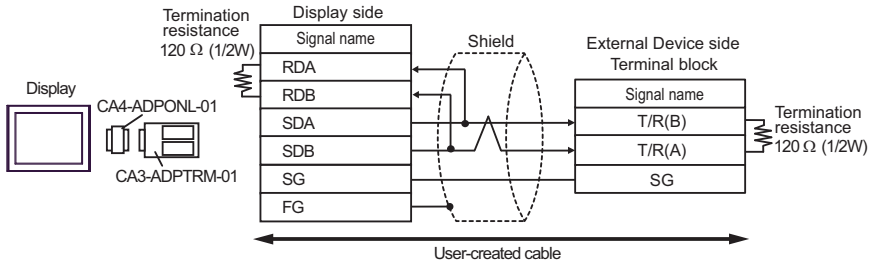

- 1:n Connection

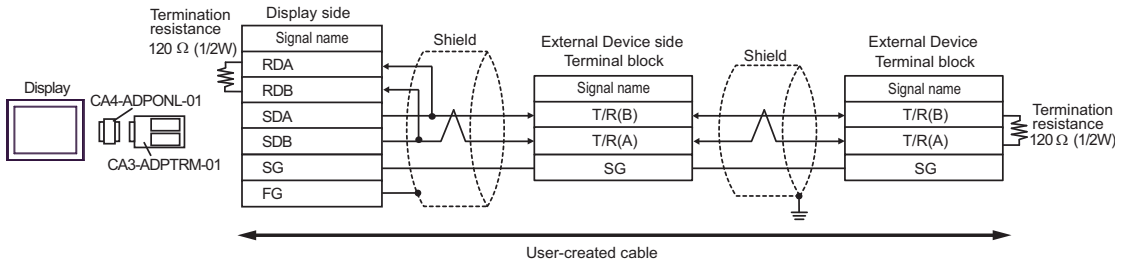

3D)

- 1:1 Connection

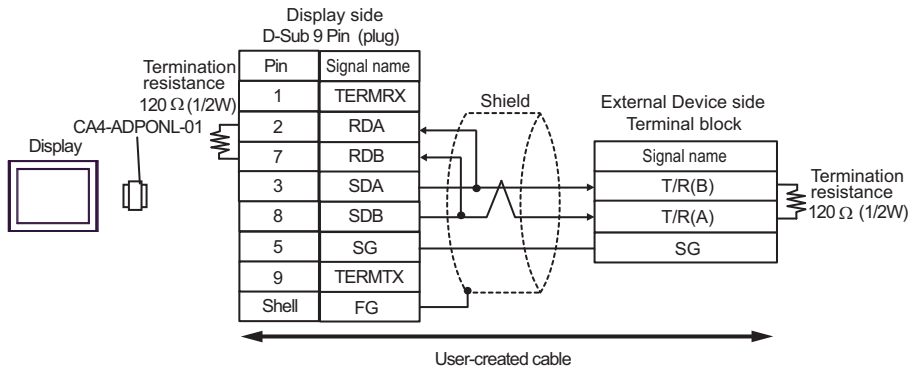

- 1:n Connection

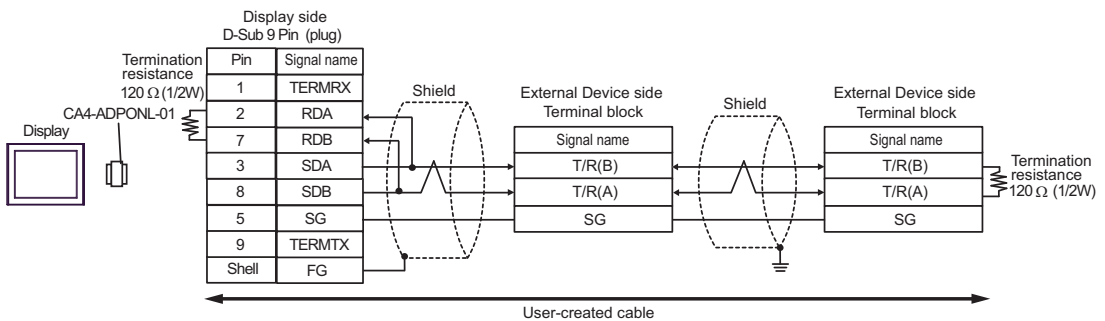

3E)

- 1:1 Connection

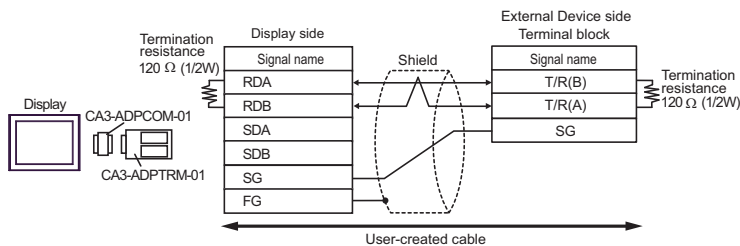

- 1:n connection

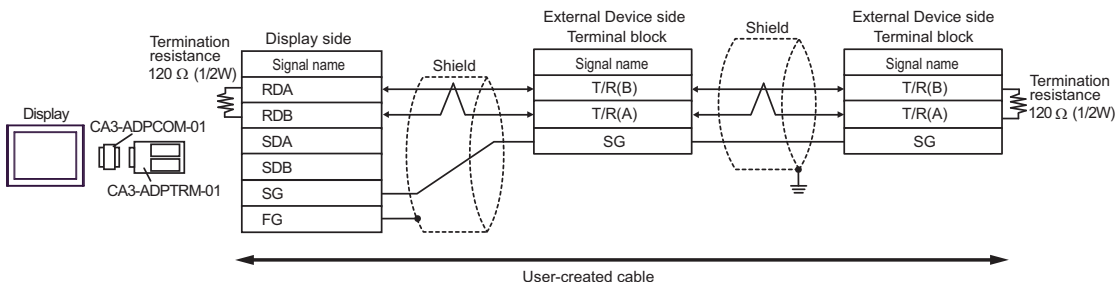

3F)

- 1:1 Connection

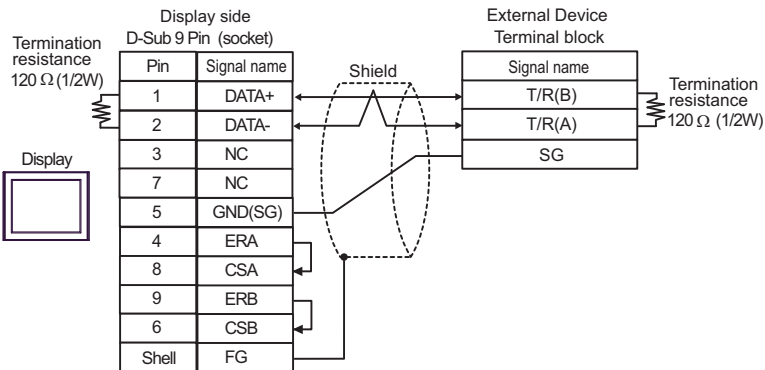

- 1:n Connection

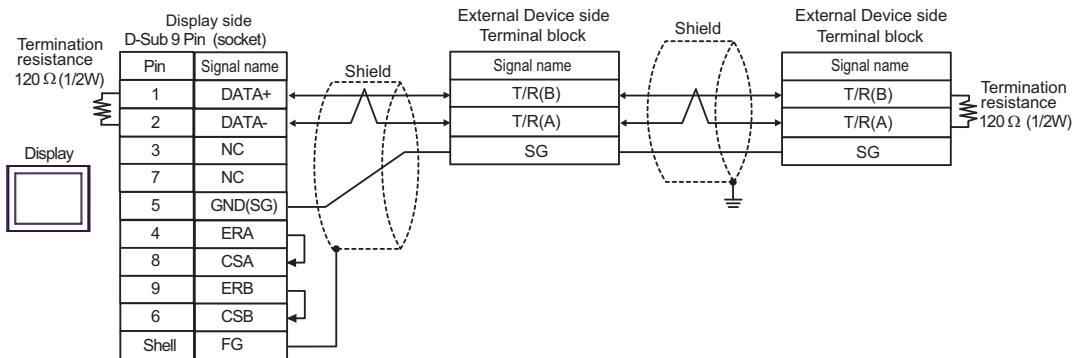

3G)

- 1:1 Connection

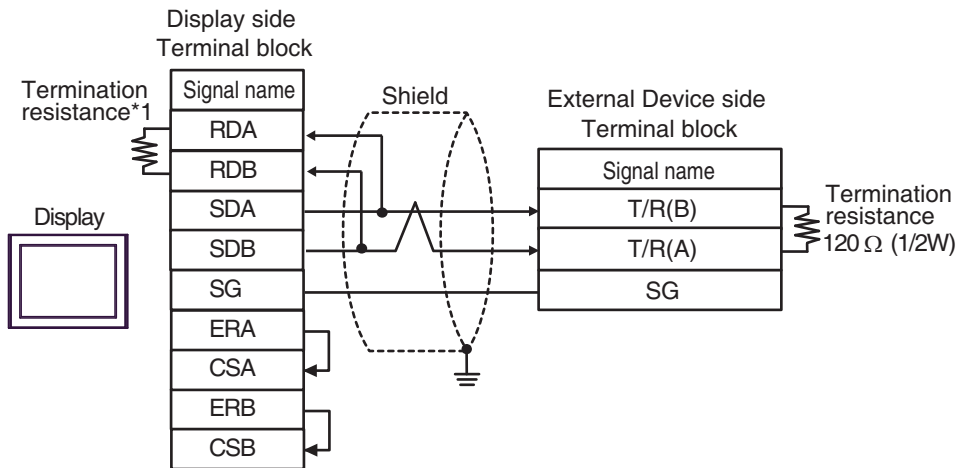

- 1:n Connection

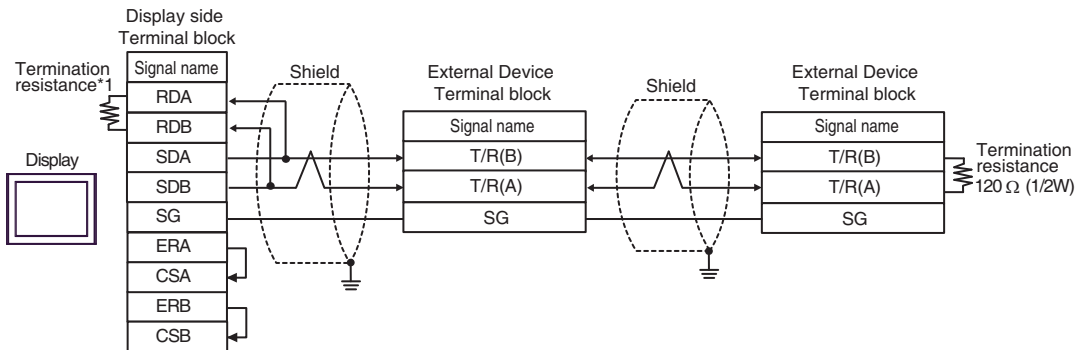

*1 The resistance in the Display is used as the termination resistance. Set the value of the DIP Switch on the rear of the Display as shown in the table below.

DIP Switch No.	Set Value
1	OFF
2	OFF
3	ON
4	ON

3H)

- 1:1 Connection

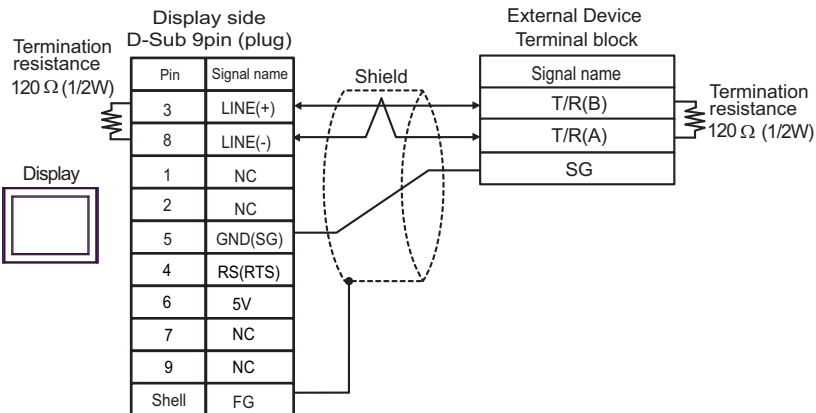

- 1:n Connection

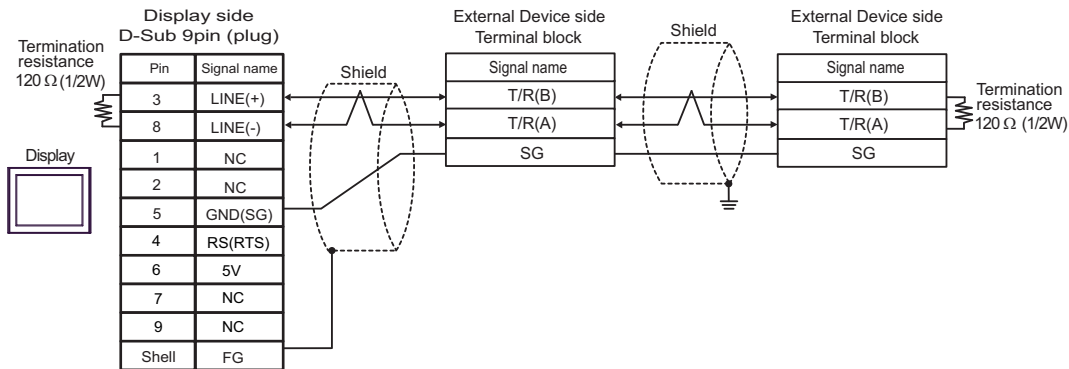

IMPORTANT

- The 5V output (Pin #6) on the Display is the power for the Siemens AG's PROFIBUS connector. Do not use it for other devices.

NOTE

- In COM on the GP-4107, the SG and FG terminals are isolated.

3I)

- 1:1 Connection

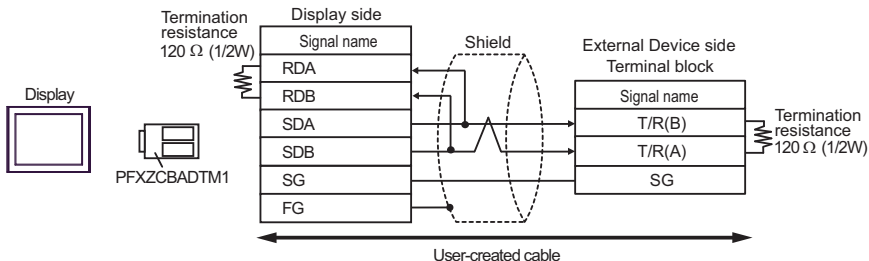

- 1: n connection

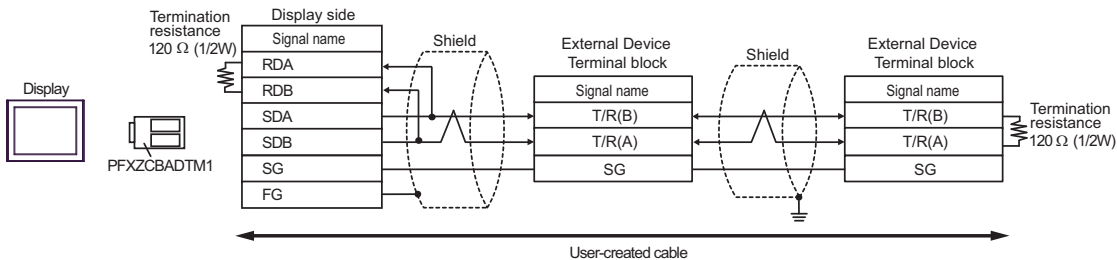

3J)

- 1:1 Connection

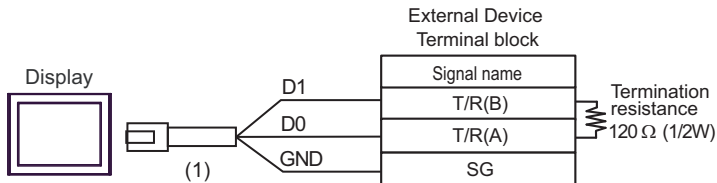

- 1:n Connection

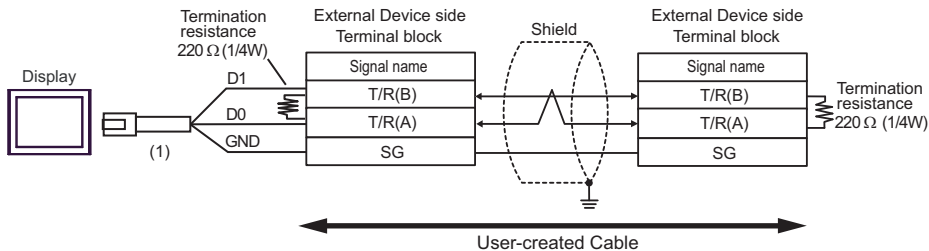

Number	Name	Notes
(1)	RJ45 RS-485 Cable (5m) by Pro-face PFXZLMCBRJ81	

3K)

- 1:1 Connection

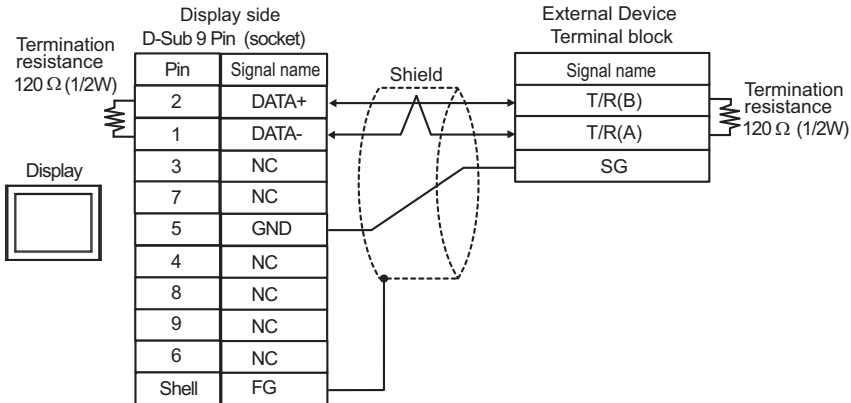

- 1:n Connection

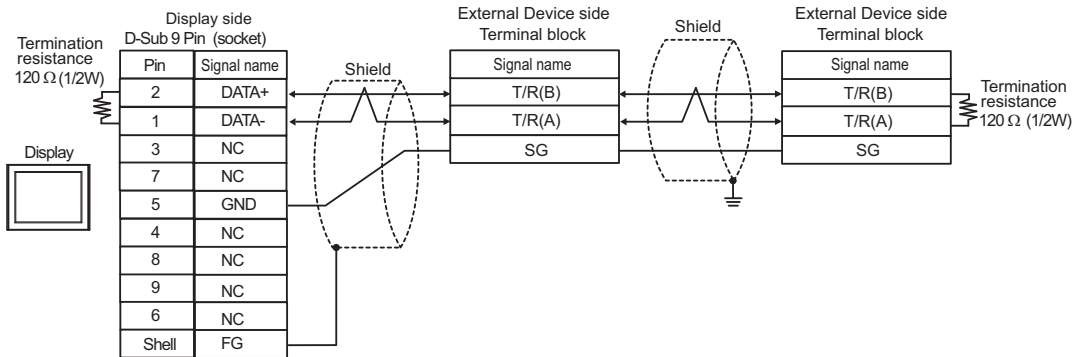

Cable Diagram 4

Display (Connection Port)	Cable		Remarks
GP3000* ¹ (COM1) AGP-3302B (COM2) GP-4*01TM (COM1) GP-Rear Module (COM1) ST3000* ² (COM2) LT3000 (COM1) IPC* ³	4A	COM port conversion adapter by Pro-face CA3-ADPCOM-01 + Terminal block conversion adapter by Pro-face CA3-ADPTRM-01 + User-created cable	Cable length: 1200m or less
	4B	User-created cable	
GP3000* ⁴ (COM2)	4C	Online adapter by Pro-face CA4-ADPONL-01 + Terminal block conversion adapter by Pro-face CA3-ADPTRM-01 + User-created cable	Cable length: 1200m or less
	4D	Online adapter by Pro-face CA4-ADPONL-01 + User-created cable	
GP-4106 (COM1) GP-4116T (COM1)	4E	User-created cable	Cable length: 1200m or less
GP4000* ⁵ (COM2) GP-4201T (COM1) SP5000* ⁶ (COM1/2) SP-5B00 (COM2) ST6000* ⁷ (COM2) ST-6200 (COM1) STM6000 (COM1) STC6000 (COM1) ET6000* ⁸ (COM2) PS6000 (Basic Box) (COM1/2)	4F	RS-422 terminal block conversion adapter by Pro-face PFXZCBADTM1* ⁹ + User-created cable	Cable length: 1200m or less
	4B	User-created cable	
PE-4000B* ¹⁰ PS5000* ¹⁰ PS6000 (Optional Interface)* ¹⁰	4G	User-created cable	Cable length: 1200m or less

*1 All GP3000 models except AGP-3302B

*2 Except AST-3211A and AST-3302B

*3 Only the COM port which can communicate by RS-422/485 (4 wire) can be used. (Except PE-4000B, PS5000, and PS6000)

 ■ IPC COM Port (page 7)

*4 All GP3000 models except GP-3200 series and AGP-3302B

*5 All GP4000 models except GP-4100 series, GP-4*01TM, GP-Rear Module, GP-4201T and GP-4*03T

*6 Except SP-5B00

*7 Except ST-6200

*8 Due to the COM port specifications, flow control is not possible. Omit wiring the control pins on the Display side of the cable diagram.

- *9 When using a Terminal Block Conversion Adapter (CA3-ADPTRM-01) instead of the RS-422 Terminal Block Conversion Adapter, refer to Cable Diagram 4A.
- *10 Only the COM port which can communicate by RS-422/485 (4 wire) can be used.
 -  ■ IPC COM Port (page 7)

4A)

- 1:1 Connection

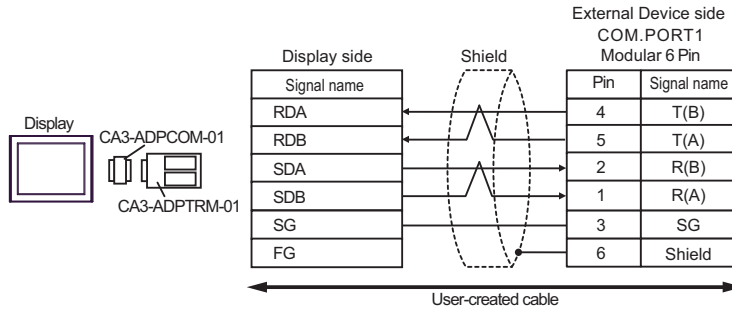

- 1: n connection

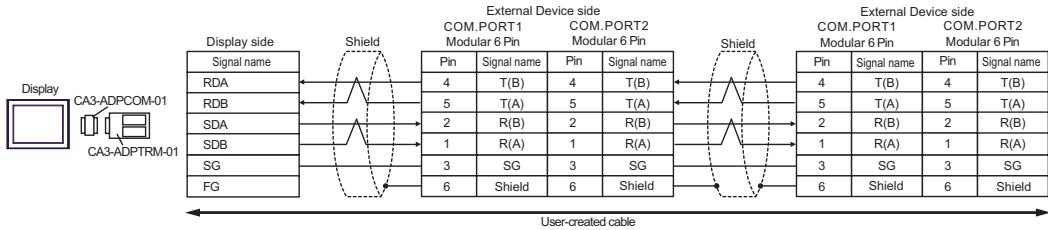

NOTE • Termination resistance is not necessary.

4B)

- 1:1 Connection

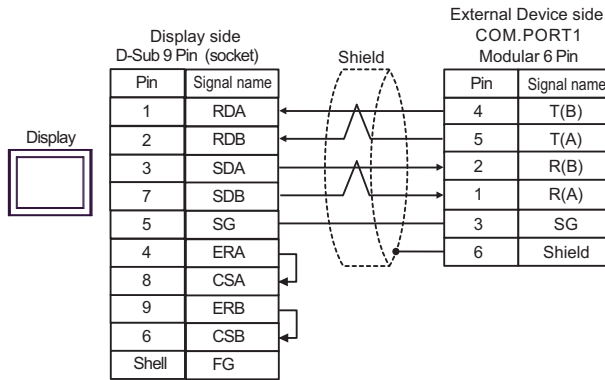

- 1:n Connection

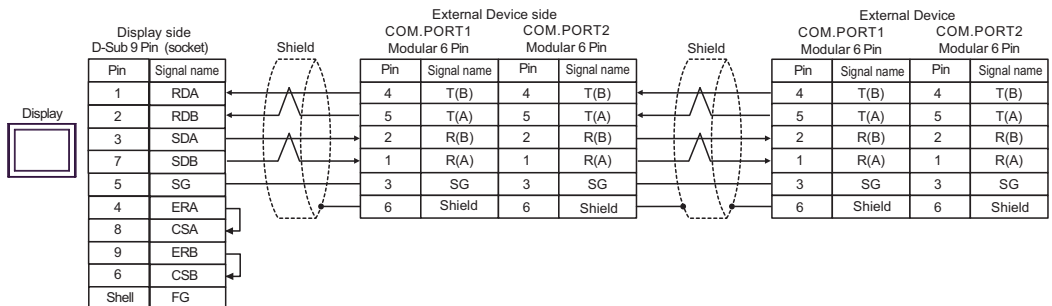

NOTE • Termination resistance is not necessary.

4C)

- 1:1 Connection

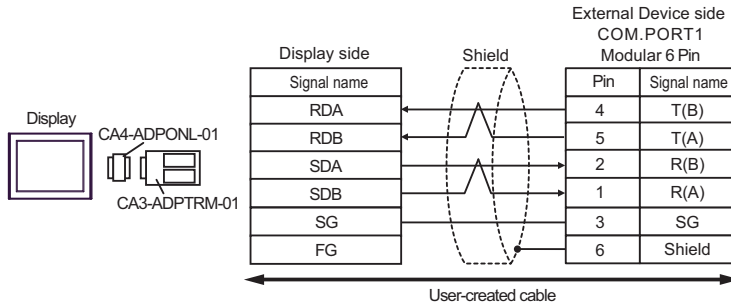

- 1:n Connection

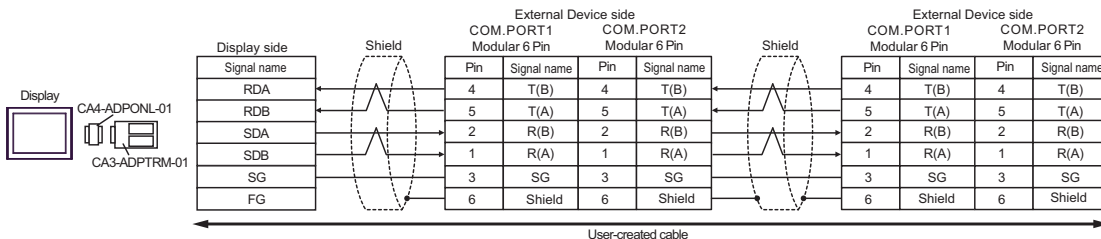

NOTE • Termination resistance is not necessary.

4D)

- 1:1 Connection

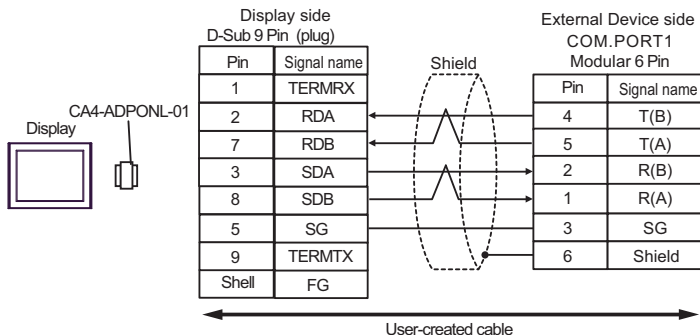

- 1:n Connection

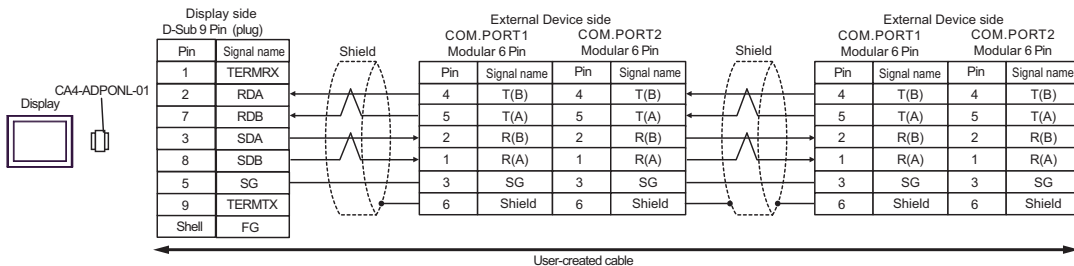

NOTE • Termination resistance is not necessary.

4E)

- 1:1 Connection

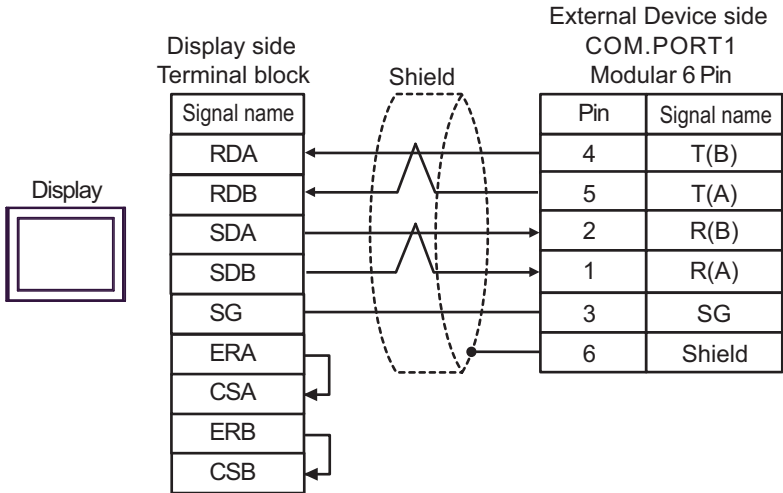

- 1:n Connection

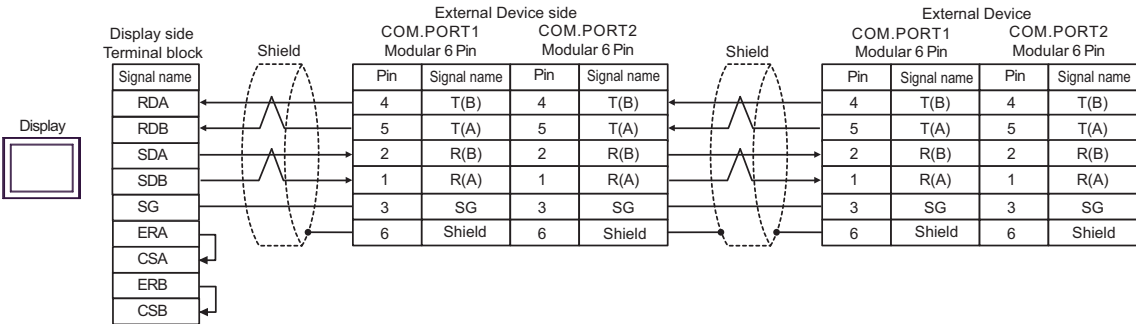

NOTE • Termination resistance is not necessary.

4F)

- 1:1 Connection

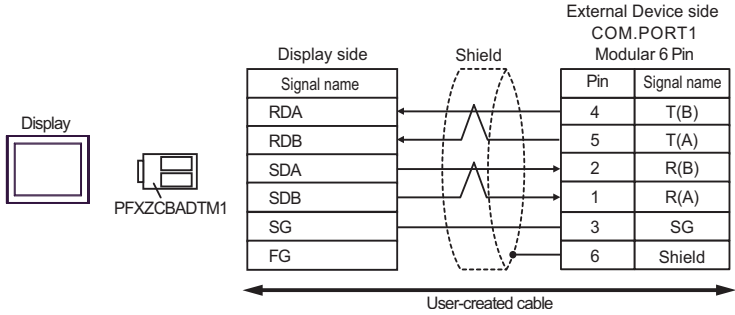

- 1: n connection

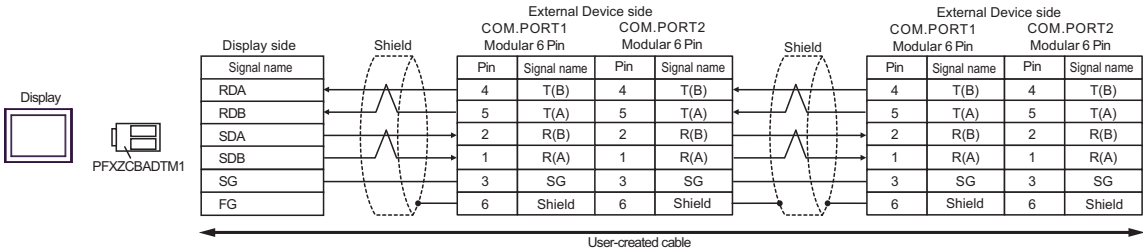

NOTE • Termination resistance is not necessary.

4G)

- 1:1 Connection

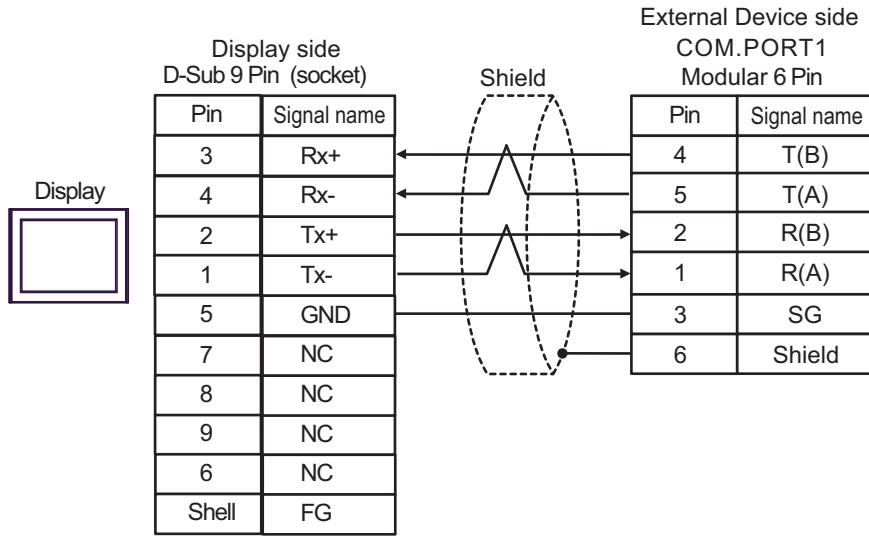

- 1:n Connection

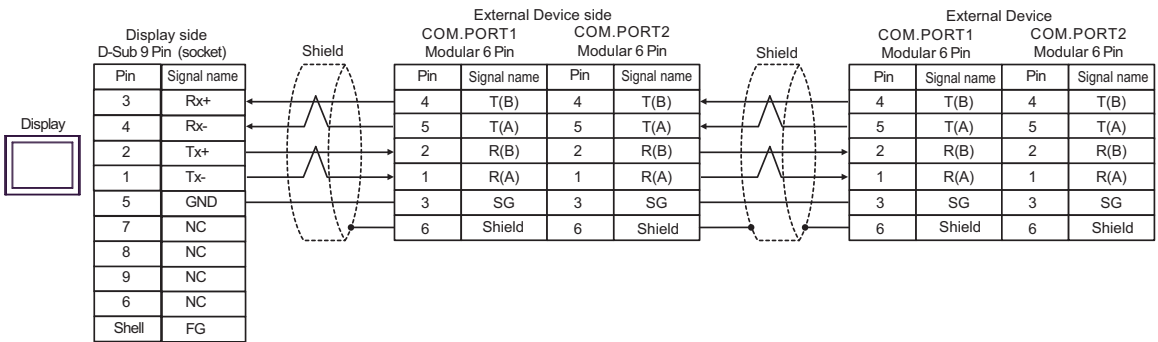

NOTE • Termination resistance is not necessary.

Cable Diagram 5

Display (Connection Port)	Cable		Remarks
GP3000* ¹ (COM1) AGP-3302B (COM2) GP-4*01TM (COM1) GP-Rear Module (COM1) ST3000* ² (COM2) LT3000 (COM1)	5A	COM port conversion adapter by Pro-face CA3-ADPCOM-01 + Terminal block conversion adapter by Pro-face CA3-ADPTRM-01 + User-created cable	Cable length: 1200m or less
	5B	User-created cable	
GP3000* ³ (COM2)	5C	Online adapter by Pro-face CA4-ADPONL-01 + Terminal block conversion adapter by Pro-face CA3-ADPTRM-01 + User-created cable	Cable length: 1200m or less
	5D	Online adapter by Pro-face CA4-ADPONL-01 + User-created cable	
IPC* ⁴	5E	COM port conversion adapter by Pro-face CA3-ADPCOM-01 + Terminal block conversion adapter by Pro-face CA3-ADPTRM-01 + User-created cable	Cable length: 1200m or less
	5F	User-created cable	
GP-4106 (COM1) GP-4116T (COM1)	5G	User-created cable	Cable length: 1200m or less
GP-4107 (COM1) GP-4*03T* ⁵ (COM2) GP-4203T (COM1)	5H	User-created cable	Cable length: 1200m or less
GP4000* ⁶ (COM2) GP-4201T (COM1) SP5000* ⁷ (COM1/2) SP-5B00 (COM2) ST6000* ⁸ (COM2) ST-6200 (COM1) STM6000 (COM1) STC6000 (COM1) ET6000* ⁹ (COM2) PS6000 (Basic Box) (COM1/2)	5I	RS-422 terminal block conversion adapter by Pro-face PFXZCBADTM1* ¹⁰ + User-created cable	Cable length: 1200m or less
	5B	User-created cable	
LT-4*01TM (COM1) LT-Rear Module (COM1)	5J	RJ45 RS-485 Cable (5m) by Pro-face PFXZLMCBJR81	Cable length: 200m or less
PE-4000B* ¹¹ PS5000* ¹¹ PS6000 (Optional Interface)* ¹¹	5K	User-created cable	Cable length: 1200m or less

*1 All GP3000 models except AGP-3302B

- *2 Except AST-3211A and AST-3302B
- *3 All GP3000 models except GP-3200 series and AGP-3302B
- *4 Only the COM port which can communicate by RS-422/485 (2 wire) can be used. (Except PE-4000B, PS5000, and PS6000)
 - ☞ ■ IPC COM Port (page 7)
- *5 Except GP-4203T
- *6 All GP4000 models except GP-4100 series, GP-4*01TM, GP-Rear Module, GP-4201T and GP-4*03T
- *7 Except SP-5B00
- *8 Except ST-6200
- *9 Due to the COM port specifications, flow control is not possible. Omit wiring the control pins on the Display side of the cable diagram.
- *10 When using a Terminal Block Conversion Adapter (CA3-ADPTRM-01) instead of the RS-422 Terminal Block Conversion Adapter, refer to Cable Diagram 5A.
- *11 Only the COM port which can communicate by RS-422/485 (2 wire) can be used.
 - ☞ ■ IPC COM Port (page 7)

5A)

- 1:1 Connection

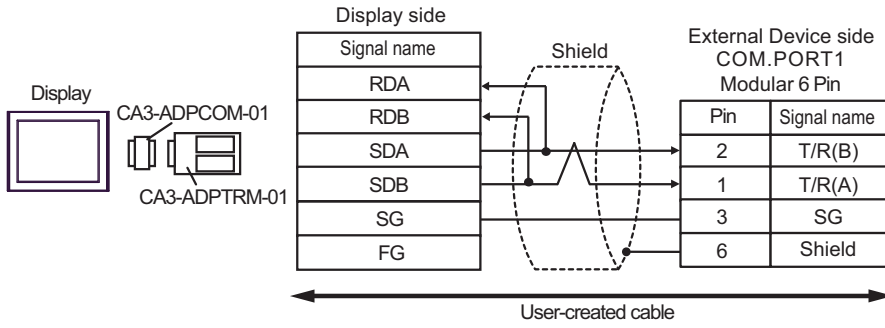

- 1: n connection

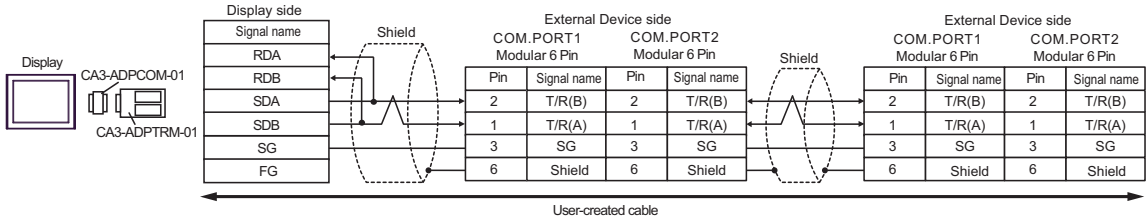

NOTE • Termination resistance is not necessary.

5B)

- 1:1 Connection

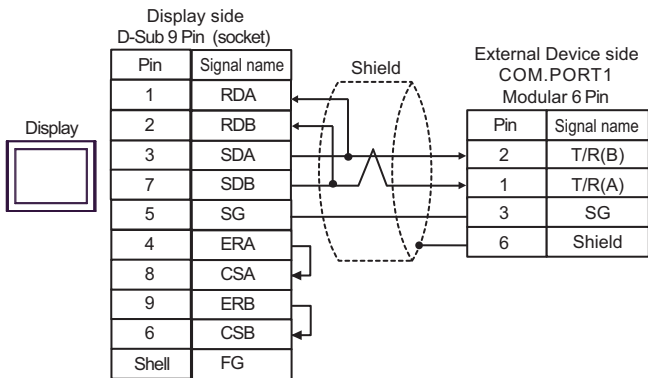

- 1:n Connection

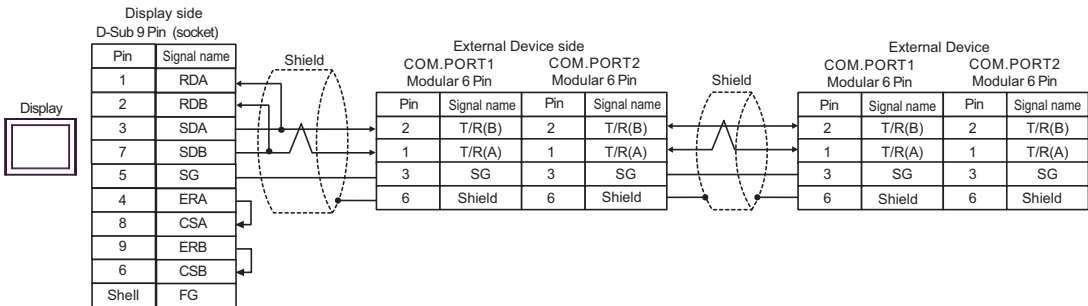

NOTE • Termination resistance is not necessary.

5C)

- 1:1 Connection

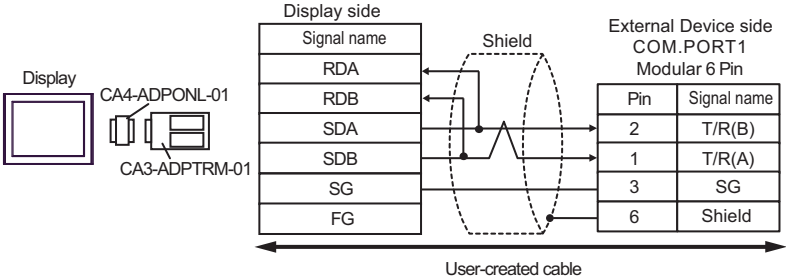

- 1:n Connection

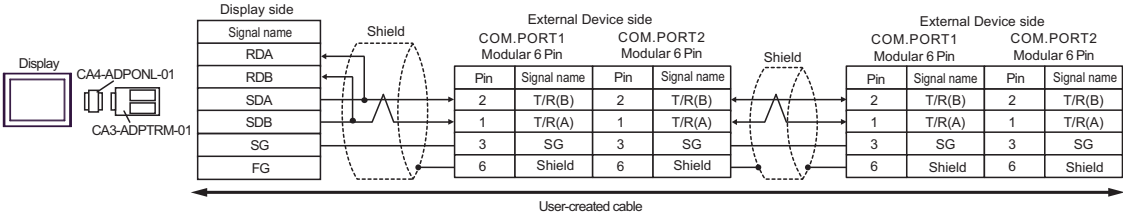

NOTE • Termination resistance is not necessary.

5D)

- 1:1 Connection

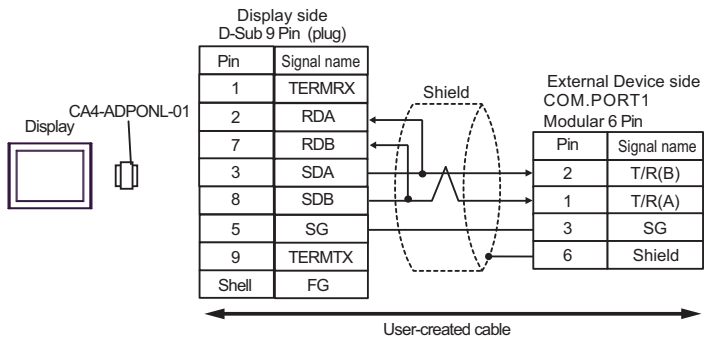

- 1:n Connection

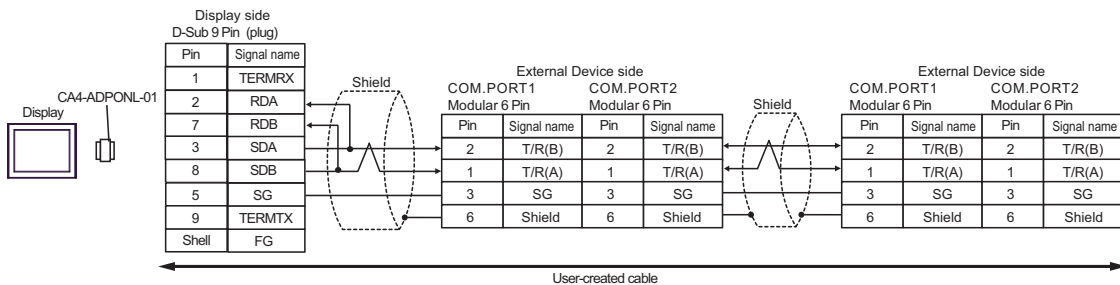

NOTE • Termination resistance is not necessary.

5E)

- 1:1 Connection

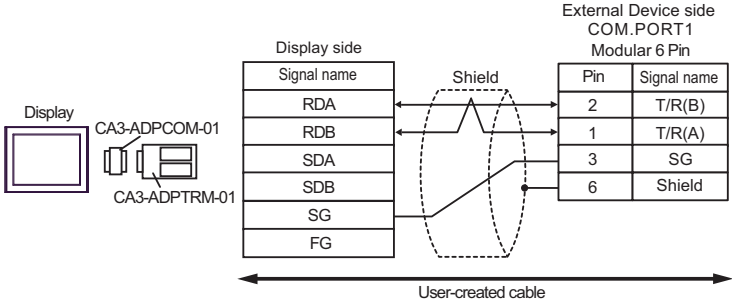

- 1: n connection

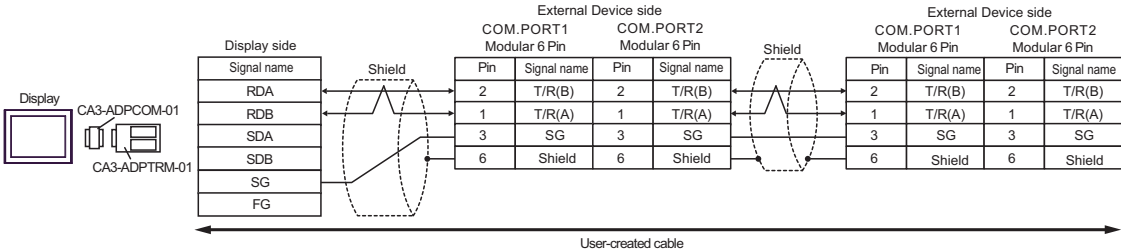

NOTE • Termination resistance is not necessary.

5F)

- 1:1 Connection

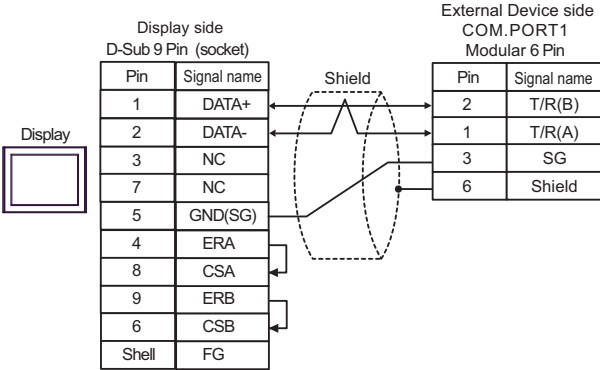

- 1:n Connection

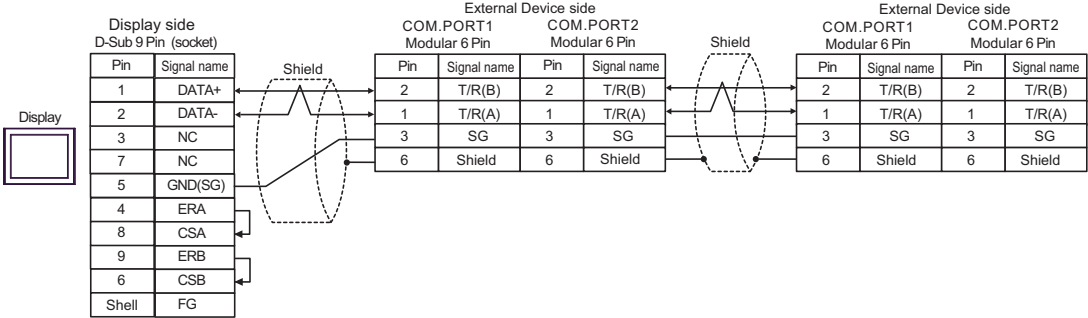

NOTE • Termination resistance is not necessary.

5G)

- 1:1 Connection

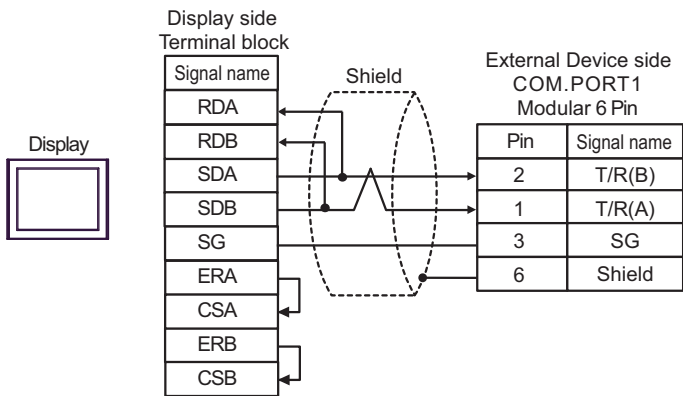

- 1:n Connection

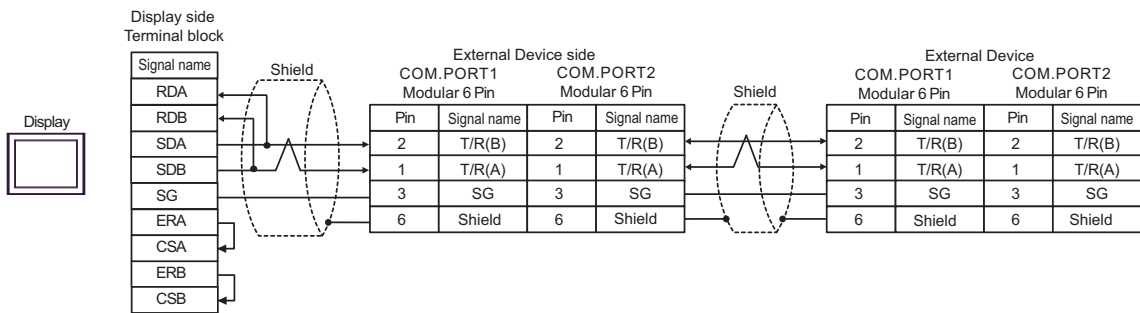

NOTE • Termination resistance is not necessary.

5H)

- 1:1 Connection

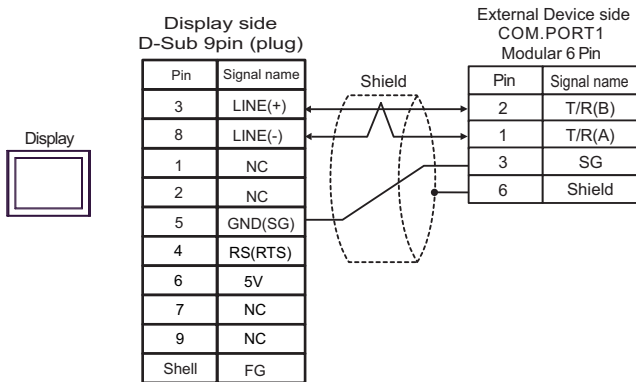

- 1:n Connection

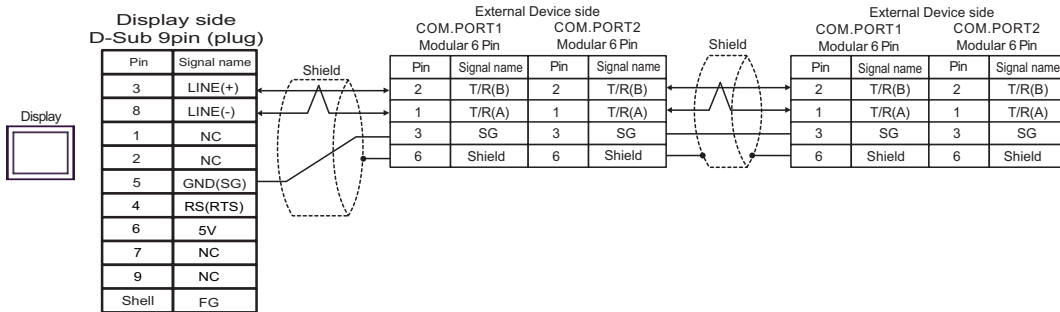

IMPORTANT

- The 5V output (Pin #6) on the Display is the power for the Siemens AG's PROFIBUS connector. Do not use it for other devices.

NOTE

- Termination resistance is not necessary.
- In COM on the GP-4107, the SG and FG terminals are isolated.

5I)

- 1:1 Connection

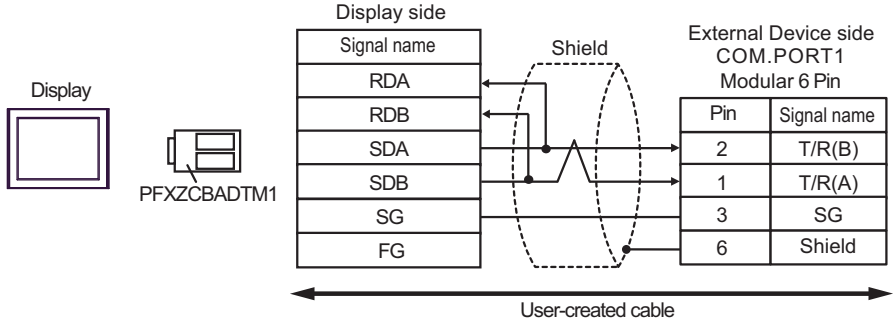

- 1: n connection

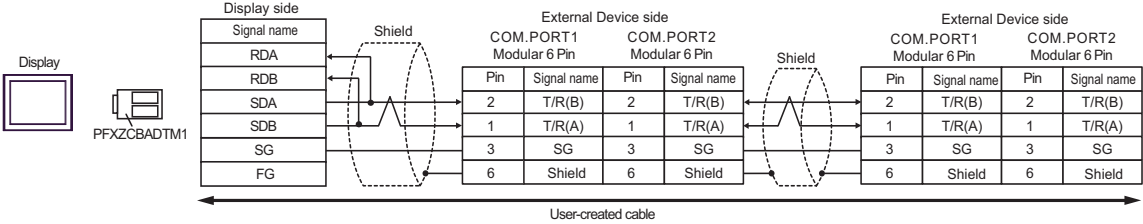

NOTE • Termination resistance is not necessary.

5J)

- 1:1 Connection

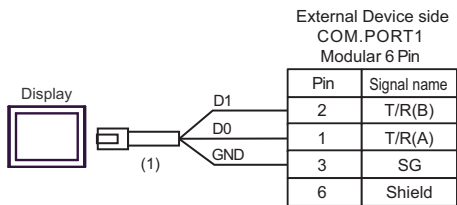

- 1:n Connection

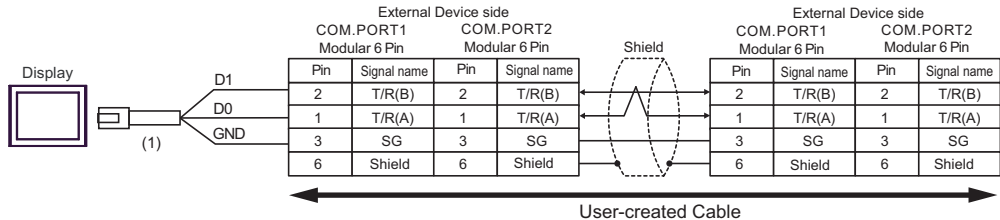

NOTE • Termination resistance is not necessary.

Number	Name	Notes
(1)	RJ45 RS-485 Cable (5m) by Pro-face PFXZLMCBJR81	

5K)

- 1:1 Connection

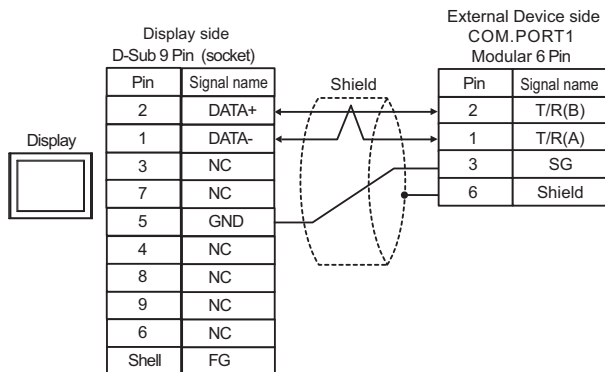

- 1:n Connection

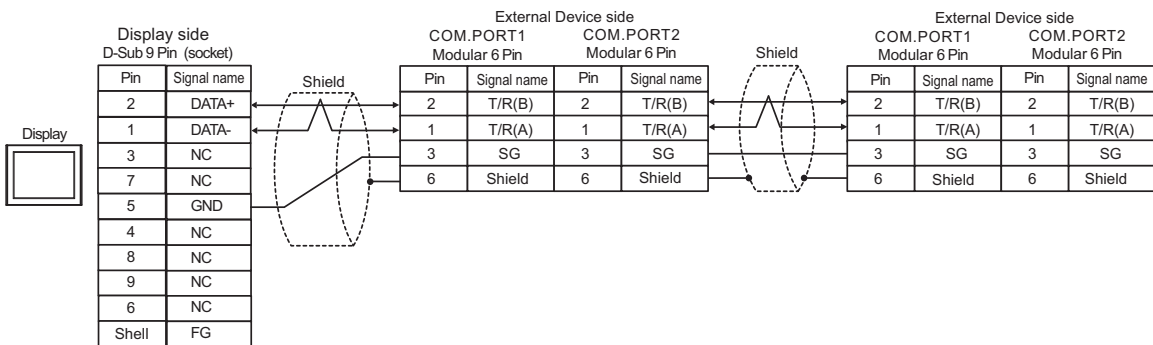

NOTE • Termination resistance is not necessary.

Cable Diagram 6

Display (Connection Port)	Cable		Remarks
GP3000 (COM1) GP4000* ¹ (COM1) SP5000* ² (COM1/2) SP-5B00 (COM1) ST3000 (COM1) ST6000 (COM1) STM6000 (COM1) STC6000 (COM1) ET6000 (COM1) LT3000 (COM1) IPC* ³ PC/AT	6A	User-created cable	Cable length: 15m or less
GP-4105 (COM1) GP-4115T (COM1) GP-4115T3 (COM1)	6B	User-created cable	Cable length: 15m or less
LT-4*01TM (COM1) LT-Rear Module (COM1)	6C	RJ45 RS-232C Cable (5m) by Pro-face PFXZLMCBJR21	Cable length: 5m or less

*1 All GP4000 models except GP-4100 Series and GP-4203T

*2 Except SP-5B00

*3 Only the COM port which can communicate by RS-232C can be used.

☞ ■ IPC COM Port (page 7)

6A)

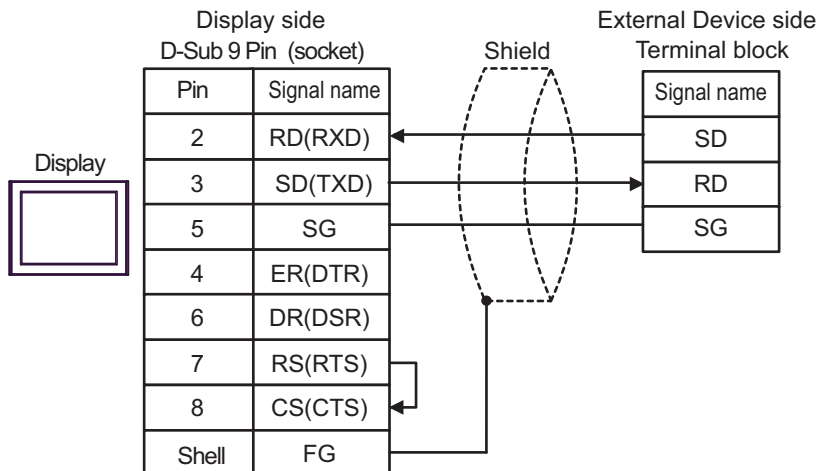

6B)

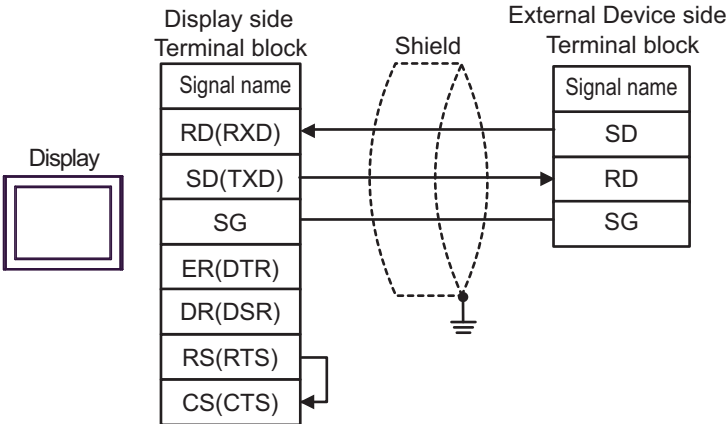

6C)

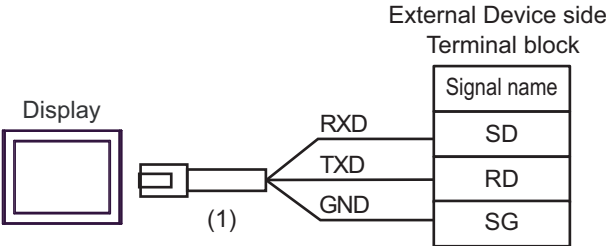

Number	Name	Notes
(1)	RJ45 RS-232C Cable (5m) by Pro-face PFXZLMCBRJ21	

Cable Diagram 7

Display (Connection Port)	Cable		Remarks
GP3000* ¹ (COM1) AGP-3302B (COM2) GP-4*01TM (COM1) GP-Rear Module (COM1) ST3000* ² (COM2) LT3000 (COM1) IPC* ³	7A	COM port conversion adapter by Pro-face CA3-ADPCOM-01 + Terminal block conversion adapter by Pro-face CA3-ADPTRM-01 + User-created cable	Cable length: 1200m or less
	7B	User-created cable	
GP3000* ⁴ (COM2)	7C	Online adapter by Pro-face CA4-ADPONL-01 + Terminal block conversion adapter by Pro-face CA3-ADPTRM-01 + User-created cable	Cable length: 1200m or less
	7D	Online adapter by Pro-face CA4-ADPONL-01 + User-created cable	
GP-4106 (COM1) GP-4116T (COM1)	7E	User-created cable	Cable length: 1200m or less
GP4000* ⁵ (COM2) GP-4201T (COM1) SP5000* ⁶ (COM1/2) SP-5B00 (COM2) ST6000* ⁷ (COM2) ST-6200 (COM1) STM6000 (COM1) STC6000 (COM1) ET6000* ⁸ (COM2) PS6000 (Basic Box) (COM1/2)	7F	RS-422 terminal block conversion adapter by Pro-face PFXZCBADTM1* ⁹ + User-created cable	Cable length: 1200m or less
	7B	User-created cable	
PE-4000B* ¹⁰ PS5000* ¹⁰ PS6000 (Optional Interface)* ¹⁰	7G	User-created cable	Cable length: 1200m or less

*1 All GP3000 models except AGP-3302B

*2 Except AST-3211A and AST-3302B

*3 Only the COM port which can communicate by RS-422/485 (4 wire) can be used. (Except PE-4000B, PS5000, and PS6000)

 ■ IPC COM Port (page 7)

*4 All GP3000 models except GP-3200 series and AGP-3302B

*5 All GP4000 models except GP-4100 series, GP-4*01TM, GP-Rear Module, GP-4201T and GP-4*03T

*6 Except SP-5B00

*7 Except ST-6200

*8 Due to the COM port specifications, flow control is not possible. Omit wiring the control pins on the Display side of the cable diagram.

- *9 When using a Terminal Block Conversion Adapter (CA3-ADPTRM-01) instead of the RS-422 Terminal Block Conversion Adapter, refer to Cable Diagram 7A.
- *10 Only the COM port which can communicate by RS-422/485 (4 wire) can be used.
 - IPC COM Port (page 7)

7A)

- 1:1 Connection

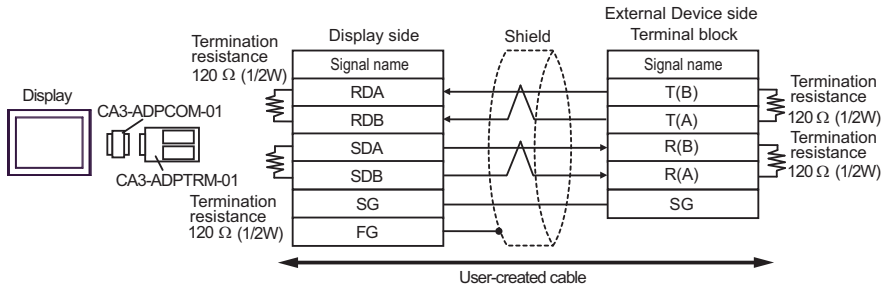

- 1: n connection

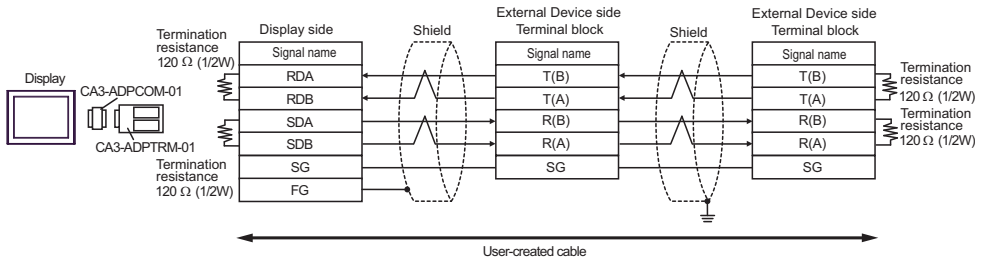

7B)

- 1:1 Connection

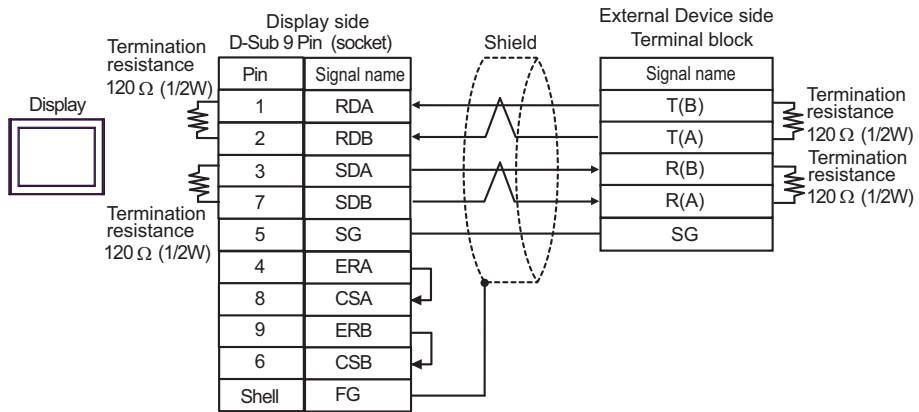

- 1:n Connection

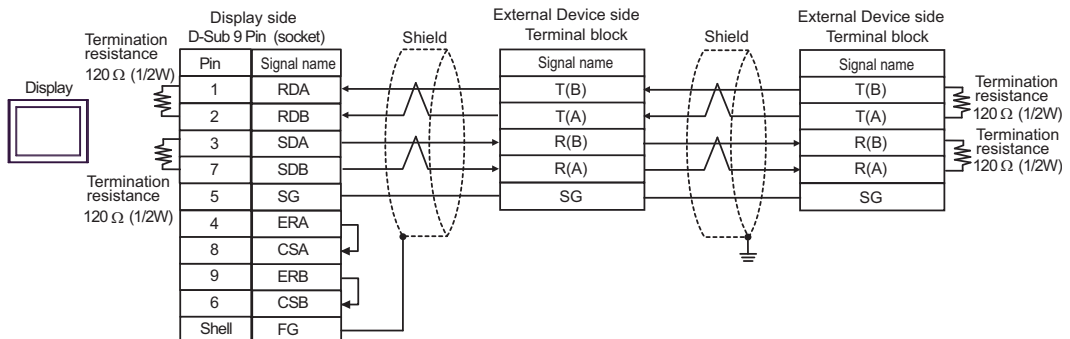

7C)

- 1:1 Connection

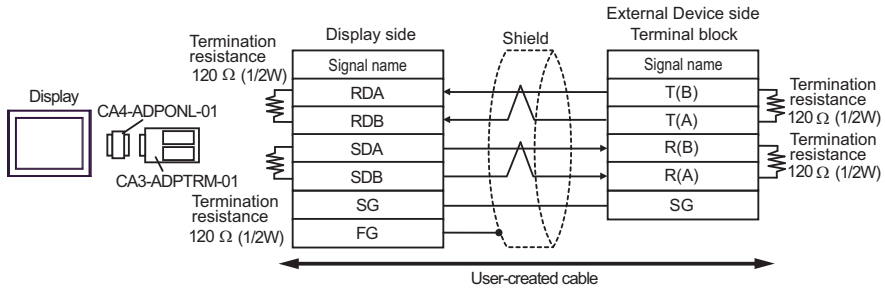

- 1:n Connection

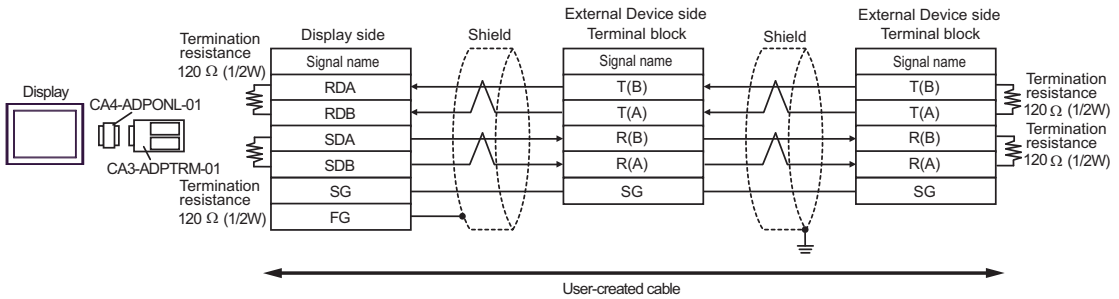

7D)

- 1:1 Connection

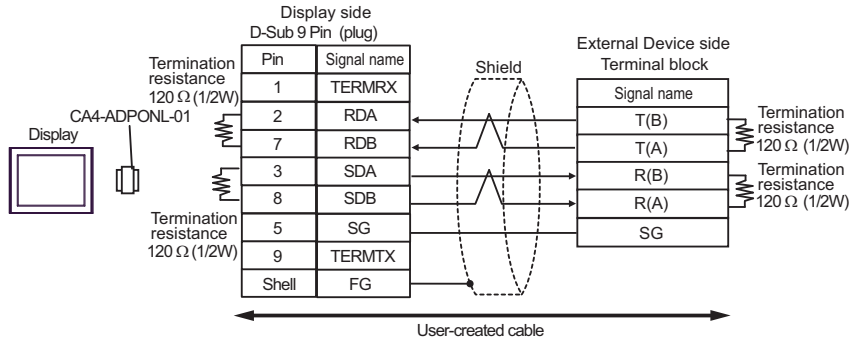

- 1:n Connection

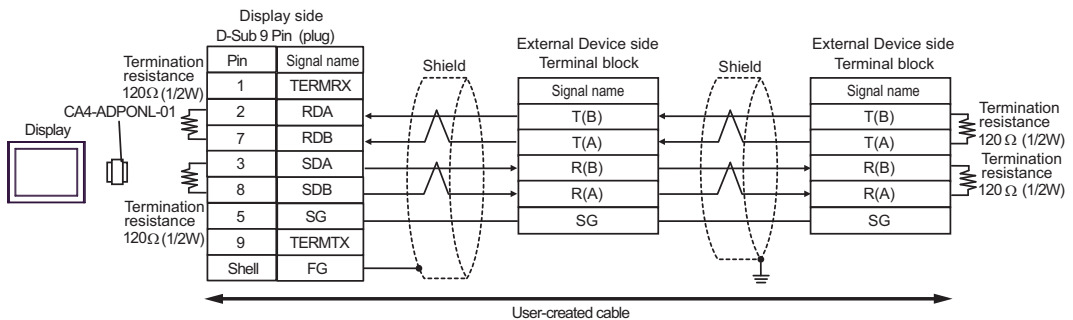

7E)

- 1:1 Connection

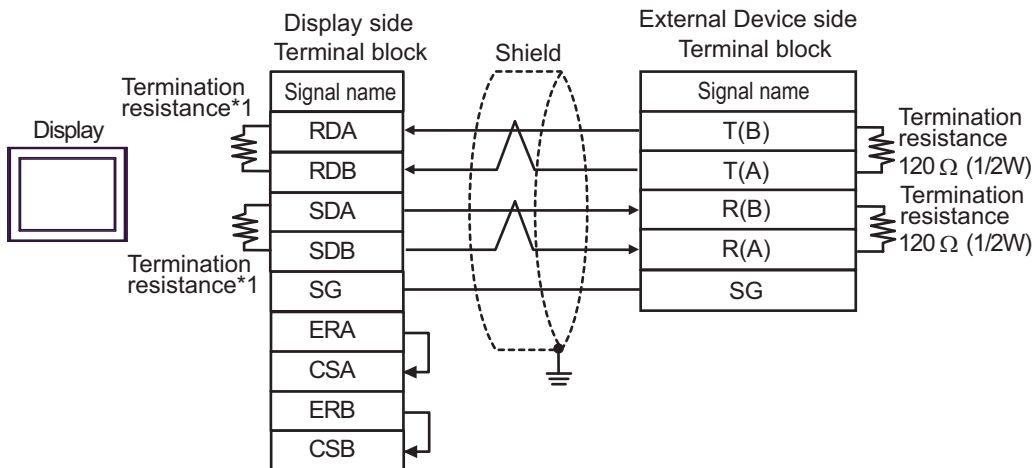

- 1:n Connection

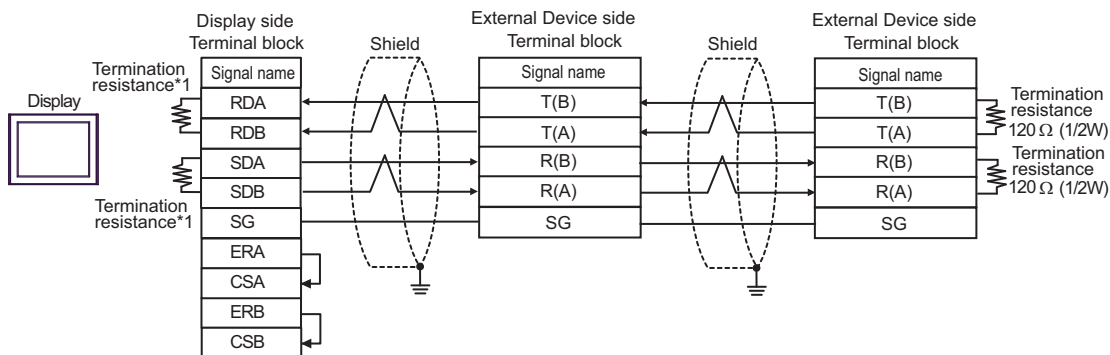

*1 The resistance in the Display is used as the termination resistance. Set the value of the DIP Switch on the rear of the Display as shown in the table below.

DIP Switch No.	Set Value
1	ON
2	ON
3	ON
4	ON

7F)

- 1:1 Connection

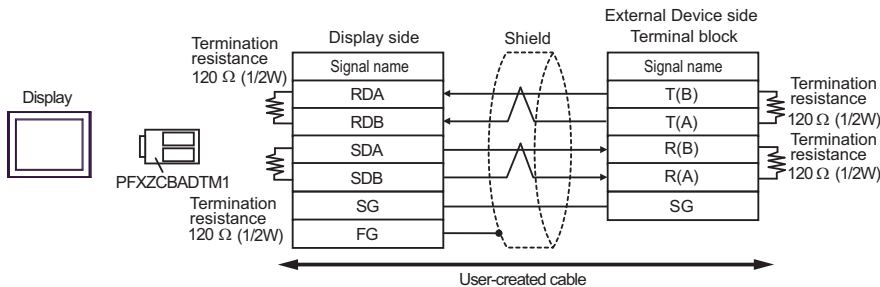

- 1:n connection

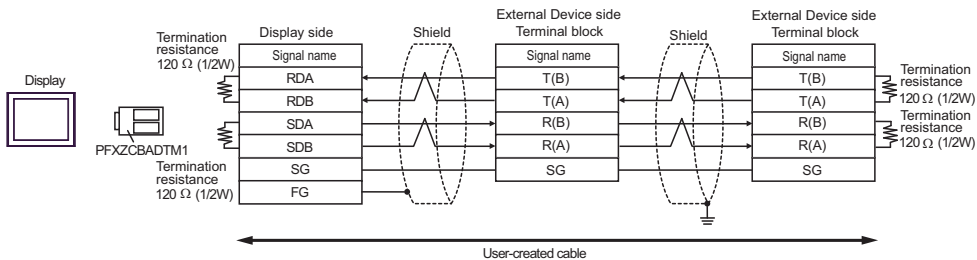

7G)

- 1:1 Connection

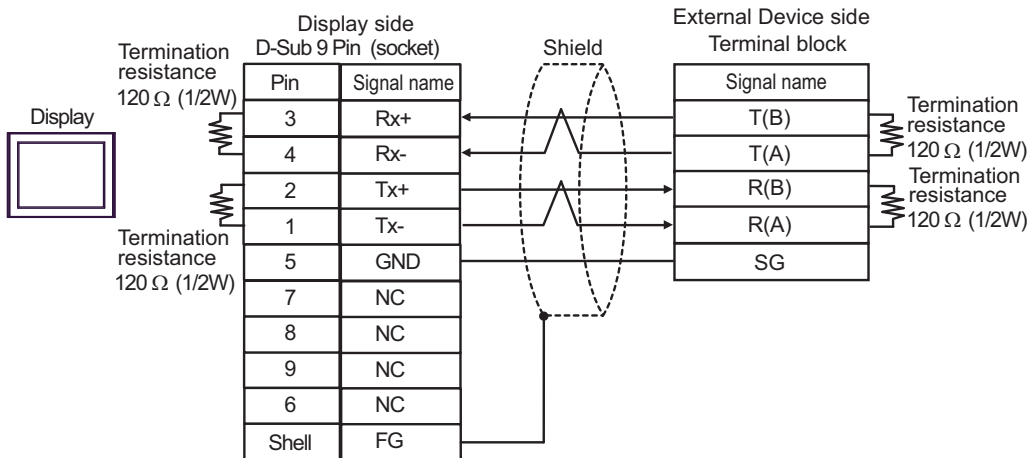

- 1:n Connection

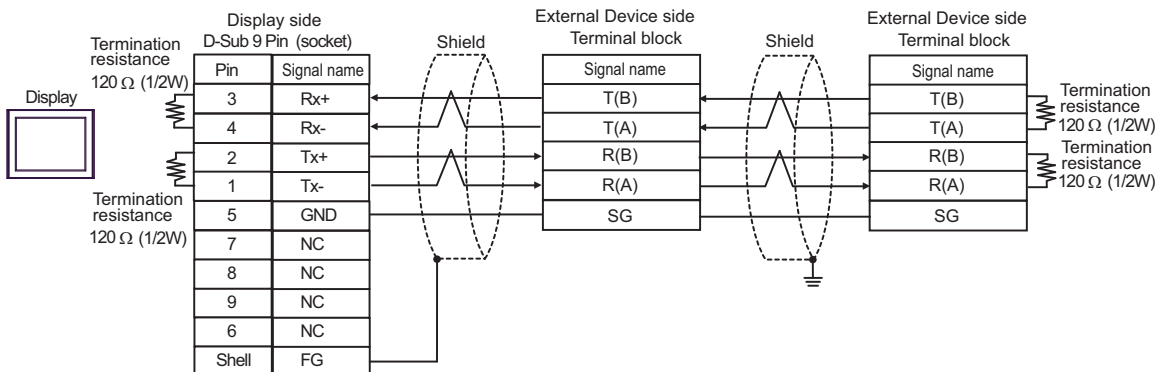

Cable Diagram 8

Display (Connection Port)	Cable		Remarks
GP3000* ¹ (COM1) AGP-3302B (COM2) GP-4*01TM (COM1) GP-Rear Module (COM1) ST3000* ² (COM2) LT3000 (COM1) IPC* ³	8A	COM port conversion adapter by Pro-face CA3-ADPCOM-01 + Terminal block conversion adapter by Pro-face CA3-ADPTRM-01 + User-created cable	Cable length: 1200m or less
	8B	User-created cable	
GP3000* ⁴ (COM2)	8C	Online adapter by Pro-face CA4-ADPONL-01 + Terminal block conversion adapter by Pro-face CA3-ADPTRM-01 + User-created cable	Cable length: 1200m or less
	8D	Online adapter by Pro-face CA4-ADPONL-01 + User-created cable	
GP-4106 (COM1) GP-4116T (COM1)	8E	User-created cable	Cable length: 1200m or less
GP4000* ⁵ (COM2) GP-4201T (COM1) SP5000* ⁶ (COM1/2) SP-5B00 (COM2) ST6000* ⁷ (COM2) ST-6200 (COM1) STM6000 (COM1) STC6000 (COM1) ET6000* ⁸ (COM2) PS6000 (Basic Box) (COM1/2)	8F	RS-422 terminal block conversion adapter by Pro-face PFXZCBADTM1* ⁹ + User-created cable	Cable length: 1200m or less
	8B	User-created cable	
PE-4000B* ¹⁰ PS5000* ¹⁰ PS6000 (Optional Interface)* ¹⁰	8G	User-created cable	Cable length: 1200m or less

*1 All GP3000 models except AGP-3302B

*2 Except AST-3211A and AST-3302B

*3 Only the COM port which can communicate by RS-422/485 (4 wire) can be used. (Except PE-4000B, PS5000, and PS6000)

 ■ IPC COM Port (page 7)

*4 All GP3000 models except GP-3200 series and AGP-3302B

*5 All GP4000 models except GP-4100 series, GP-4*01TM, GP-Rear Module, GP-4201T and GP-4*03T

*6 Except SP-5B00

*7 Except ST-6200

*8 Due to the COM port specifications, flow control is not possible. Omit wiring the control pins on the Display side of the cable diagram.

- *9 When using a Terminal Block Conversion Adapter (CA3-ADPTRM-01) instead of the RS-422 Terminal Block Conversion Adapter, refer to Cable Diagram 8A.
- *10 Only the COM port which can communicate by RS-422/485 (4 wire) can be used.
 -  ■ IPC COM Port (page 7)

8A)

- 1:1 Connection

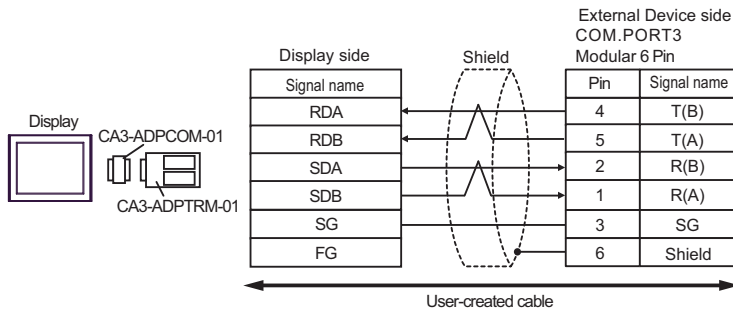

- 1: n connection

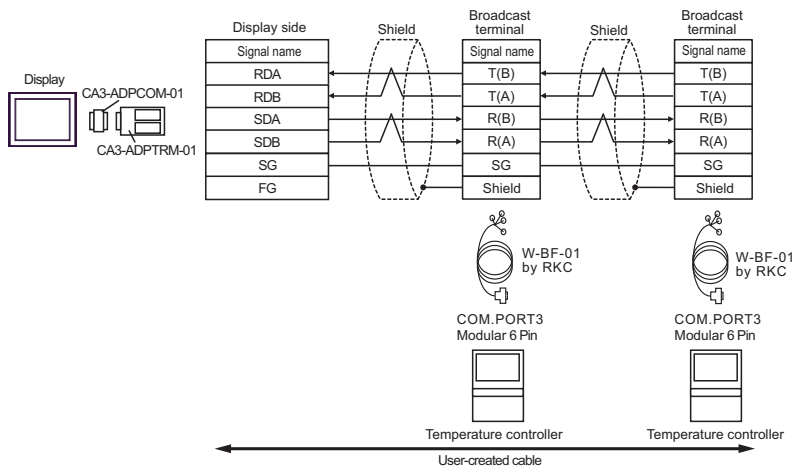

NOTE • Termination resistance is not necessary.

8B)

- 1:1 Connection

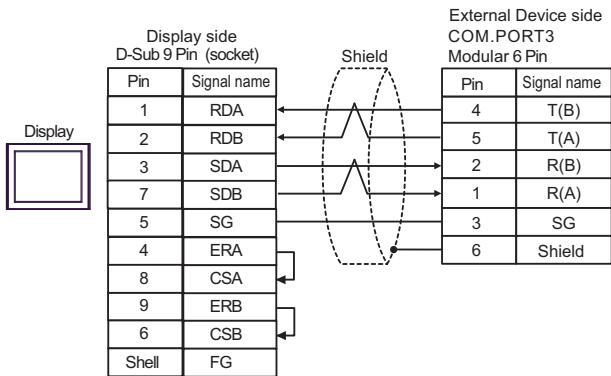

- 1:n Connection

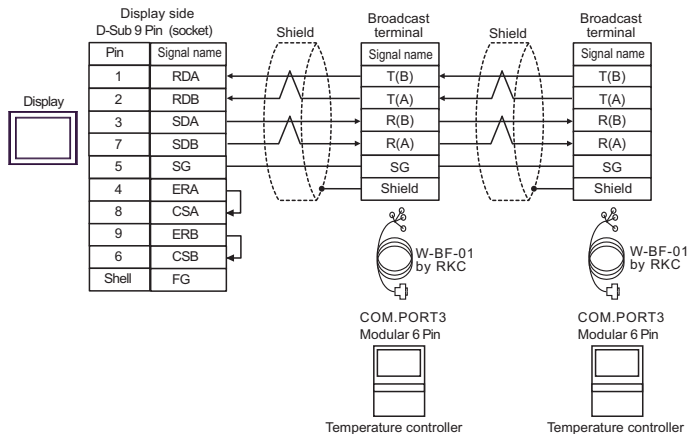

NOTE • Termination resistance is not necessary.

8C)

- 1:1 Connection

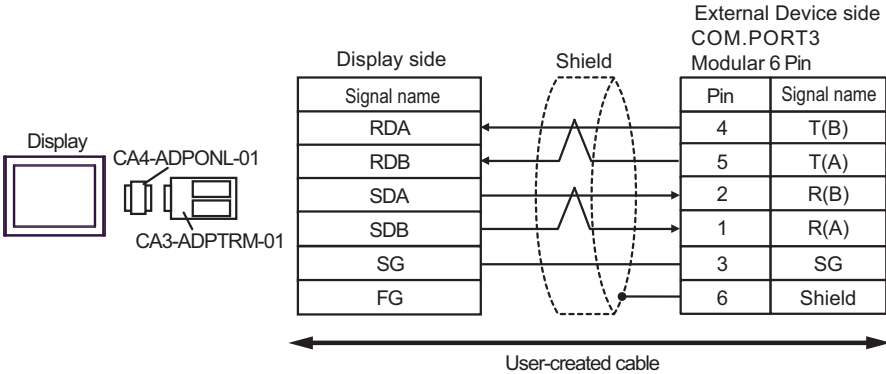

- 1:n Connection

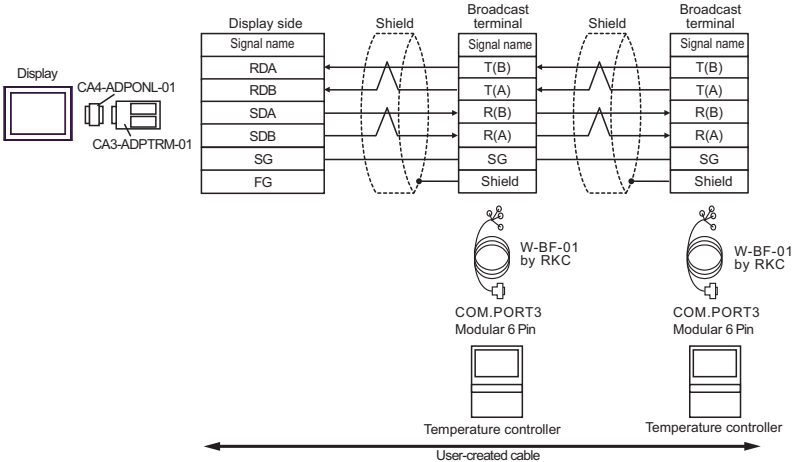

NOTE • Termination resistance is not necessary.

8D)

- 1:1 Connection

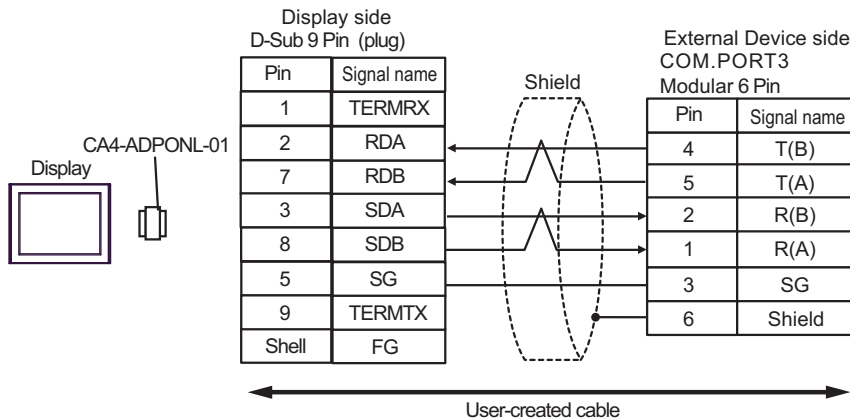

- 1:n Connection

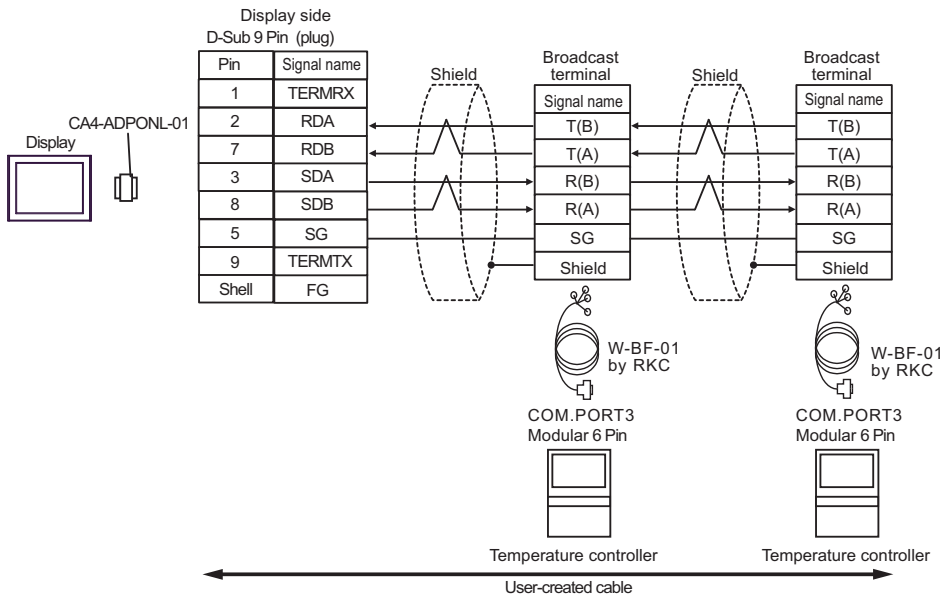

NOTE • Termination resistance is not necessary.

8E)

- 1:1 Connection

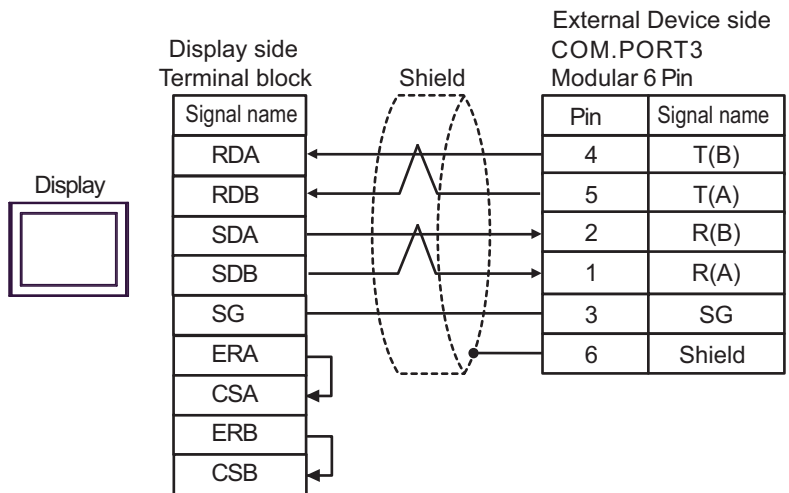

- 1:n Connection

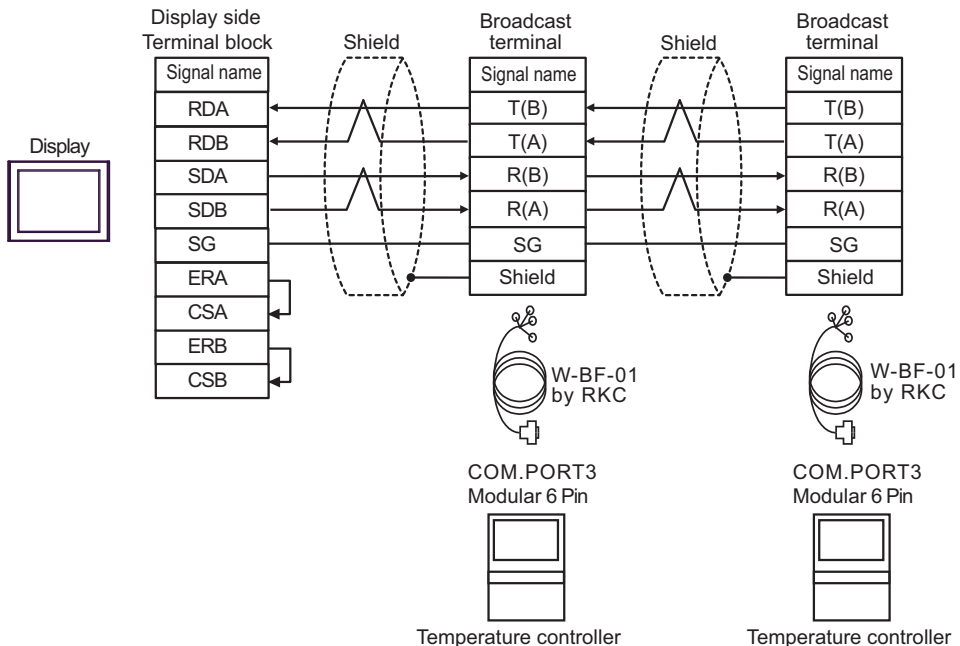

NOTE • Termination resistance is not necessary.

8F)

- 1:1 Connection

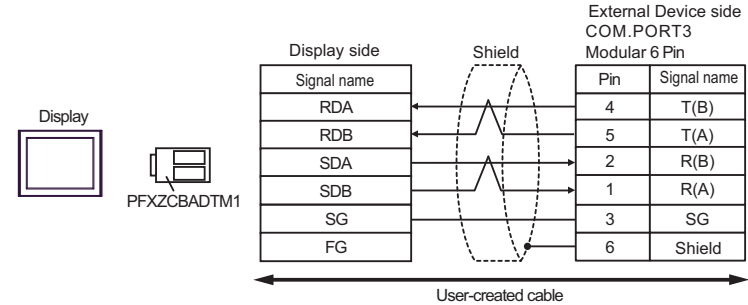

- 1: n connection

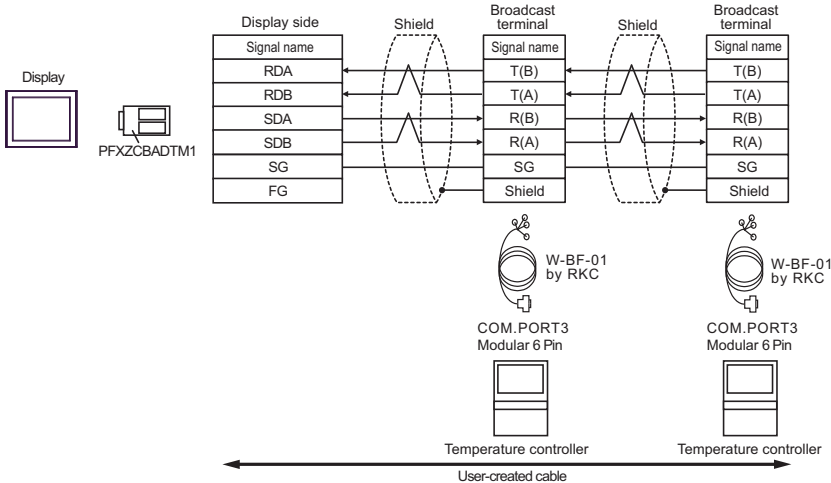

NOTE • Termination resistance is not necessary.

8G)

- 1:1 Connection

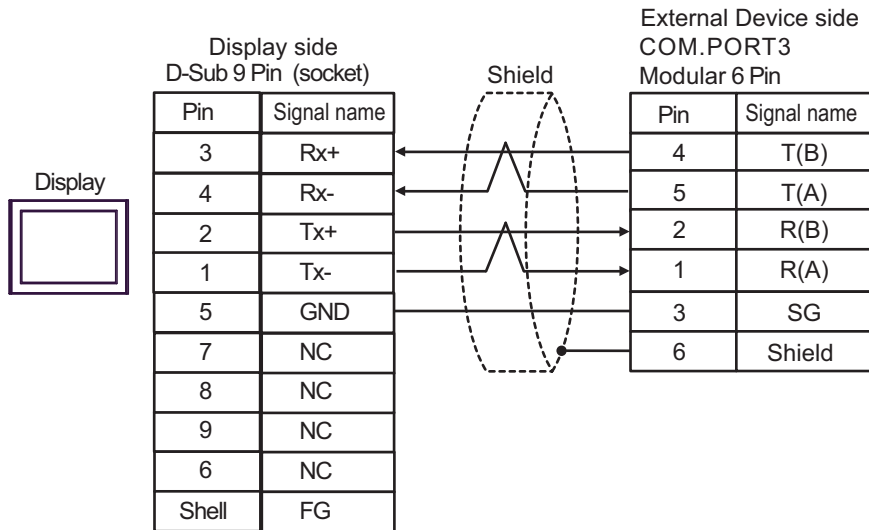

- 1:n Connection

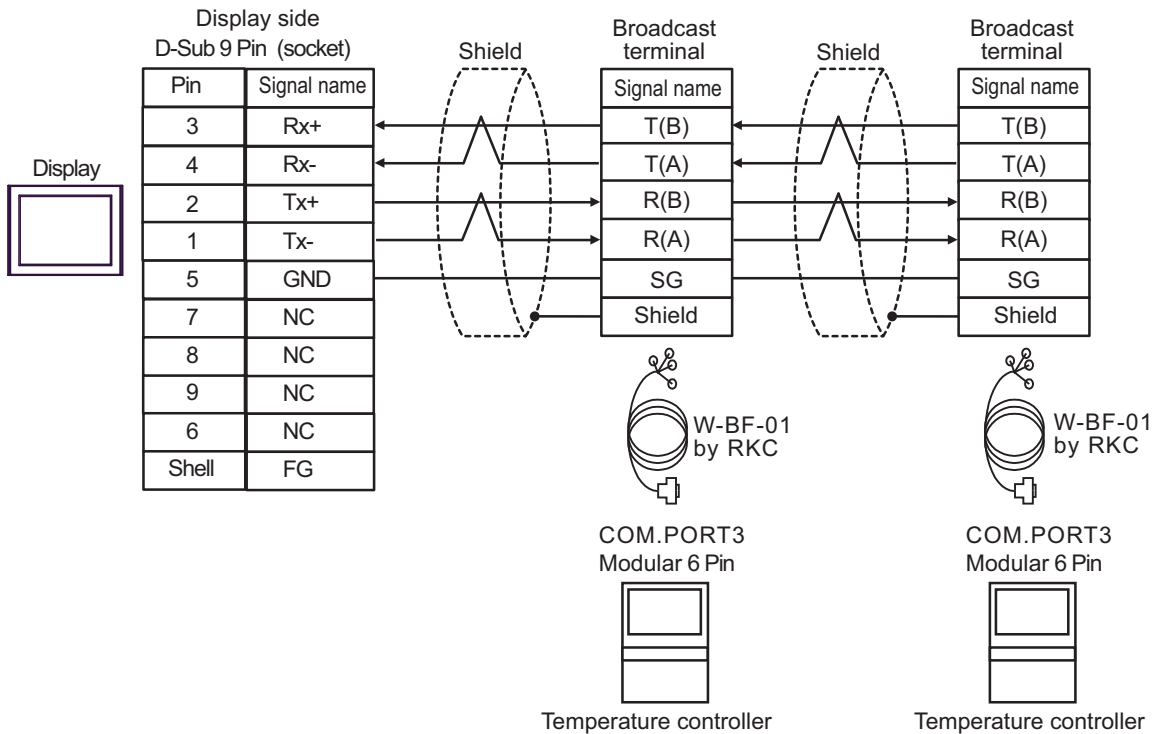

NOTE • Termination resistance is not necessary.

Cable Diagram 9

Display (Connection Port)	Cable		Remarks
GP3000* ¹ (COM1) AGP-3302B (COM2) GP-4*01TM (COM1) GP-Rear Module (COM1) ST3000* ² (COM2) LT3000 (COM1)	9A	COM port conversion adapter by Pro-face CA3-ADPCOM-01 + Terminal block conversion adapter by Pro-face CA3-ADPTRM-01 + User-created cable	Cable length: 1200m or less
	9B	User-created cable	
GP3000* ³ (COM2)	9C	Online adapter by Pro-face CA4-ADPONL-01 + Terminal block conversion adapter by Pro-face CA3-ADPTRM-01 + User-created cable	Cable length: 1200m or less
	9D	Online adapter by Pro-face CA4-ADPONL-01 + User-created cable	
IPC* ⁴	9E	COM port conversion adapter by Pro-face CA3-ADPCOM-01 + Terminal block conversion adapter by Pro-face CA3-ADPTRM-01 + User-created cable	Cable length: 1200m or less
	9F	User-created cable	
GP-4106 (COM1) GP-4116T (COM1)	9G	User-created cable	Cable length: 1200m or less
GP-4107 (COM1) GP-4*03T* ⁵ (COM2) GP-4203T (COM1)	9H	User-created cable	Cable length: 1200m or less
GP4000* ⁶ (COM2) GP-4201T (COM1) SP5000* ⁷ (COM1/2) SP-5B00 (COM2) ST6000* ⁸ (COM2) ST-6200 (COM1) STM6000 (COM1) STC6000 (COM1) ET6000* ⁹ (COM2) PS6000 (Basic Box) (COM1/2)	9I	RS-422 terminal block conversion adapter by Pro-face PFXZCBADTM1* ¹⁰ + User-created cable	Cable length: 1200m or less
	9B	User-created cable	
LT-4*01TM (COM1) LT-Rear Module (COM1)	9J	RJ45 RS-485 Cable (5m) by Pro-face PFXZLMCBJR81	Cable length: 200m or less
PE-4000B* ¹¹ PS5000* ¹¹ PS6000 (Optional Interface)* ¹¹	9K	User-created cable	Cable length: 1200m or less

*1 All GP3000 models except AGP-3302B

- *2 Except AST-3211A and AST-3302B
- *3 All GP3000 models except GP-3200 series and AGP-3302B
- *4 Only the COM port which can communicate by RS-422/485 (2 wire) can be used. (Except PE-4000B, PS5000, and PS6000)
 - ☞ ■ IPC COM Port (page 7)
- *5 Except GP-4203T
- *6 All GP4000 models except GP-4100 series, GP-4*01TM, GP-Rear Module, GP-4201T and GP-4*03T
- *7 Except SP-5B00
- *8 Except ST-6200
- *9 Due to the COM port specifications, flow control is not possible. Omit wiring the control pins on the Display side of the cable diagram.
- *10 When using a Terminal Block Conversion Adapter (CA3-ADPTRM-01) instead of the RS-422 Terminal Block Conversion Adapter, refer to Cable Diagram 9A.
- *11 Only the COM port which can communicate by RS-422/485 (2 wire) can be used.
 - ☞ ■ IPC COM Port (page 7)

9A)

- 1:1 Connection

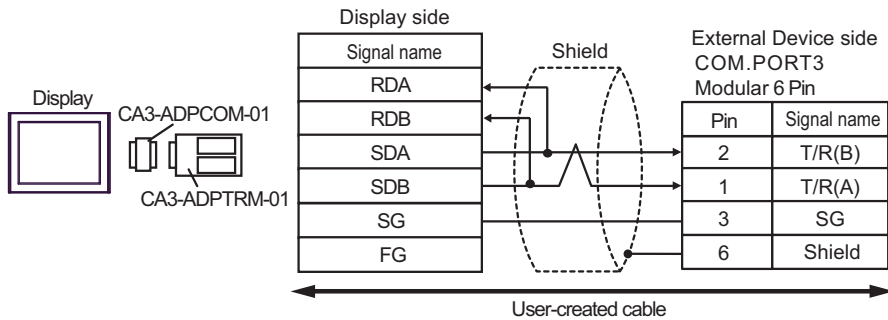

- 1: n connection

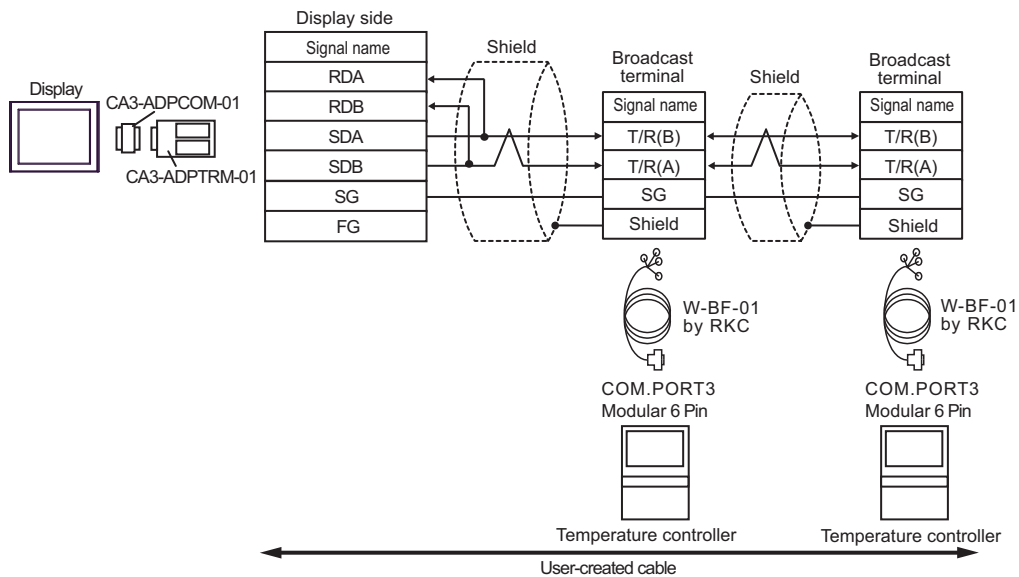

NOTE • Termination resistance is not necessary.

9B)

- 1:1 Connection

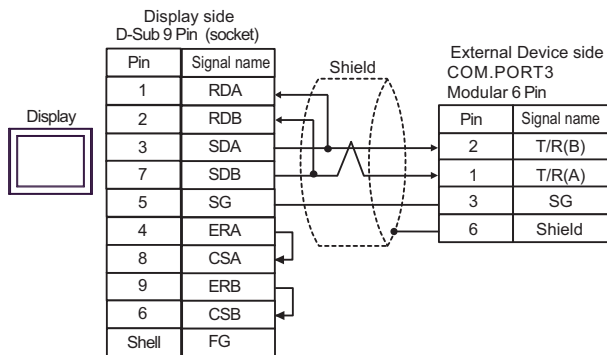

- 1:n Connection

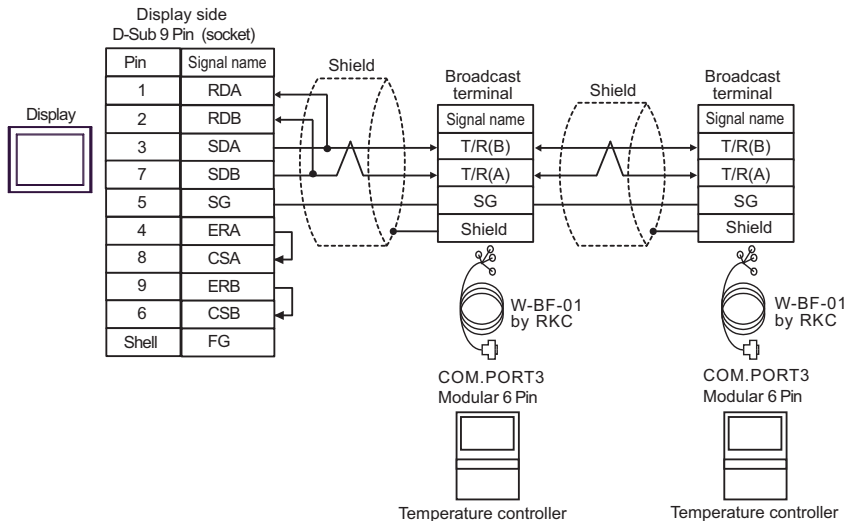

NOTE • Termination resistance is not necessary.

9C)

- 1:1 Connection

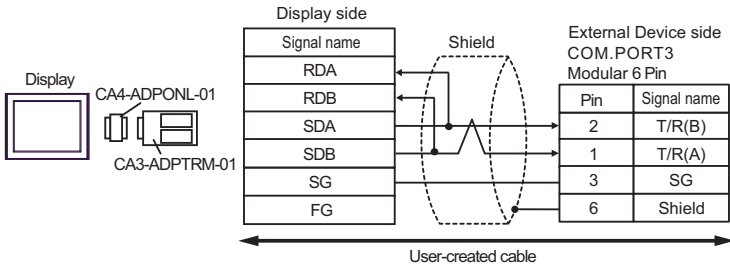

- 1:n Connection

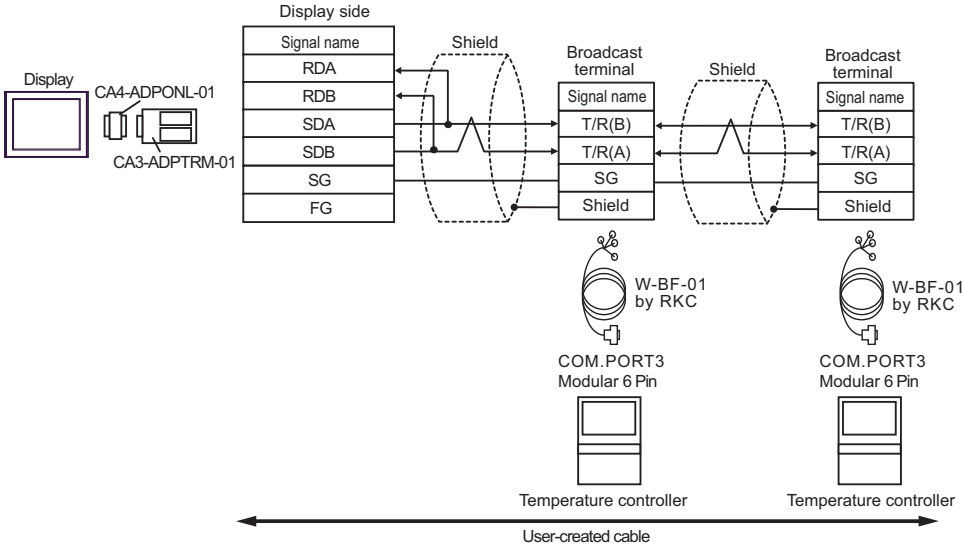

NOTE • Termination resistance is not necessary.

9D)

- 1:1 Connection

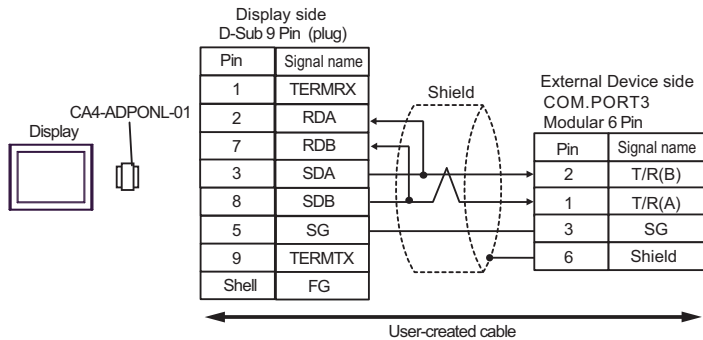

- 1:n Connection

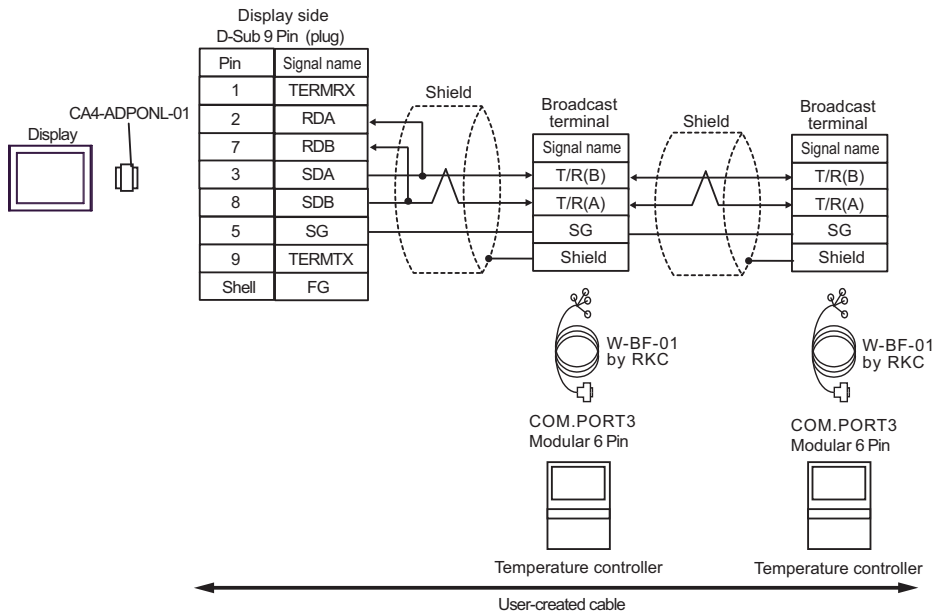

NOTE • Termination resistance is not necessary.

9E)

- 1:1 Connection

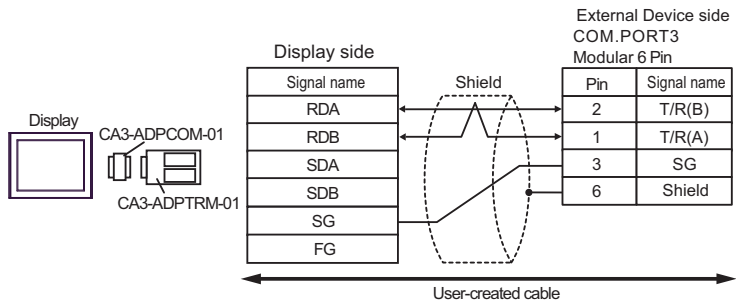

- 1: n connection

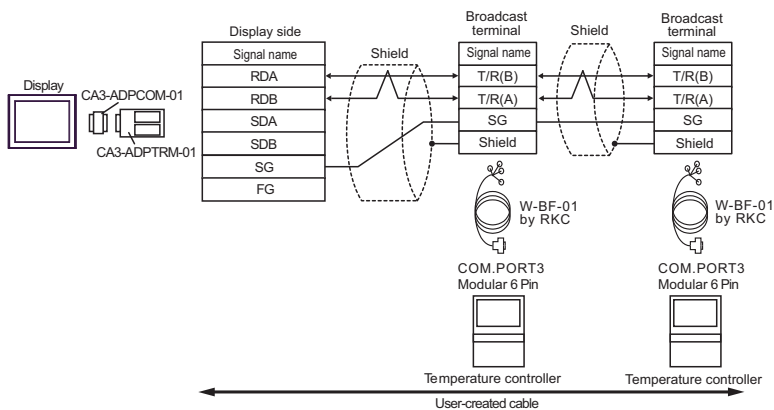

NOTE • Termination resistance is not necessary.

9F)

- 1:1 Connection

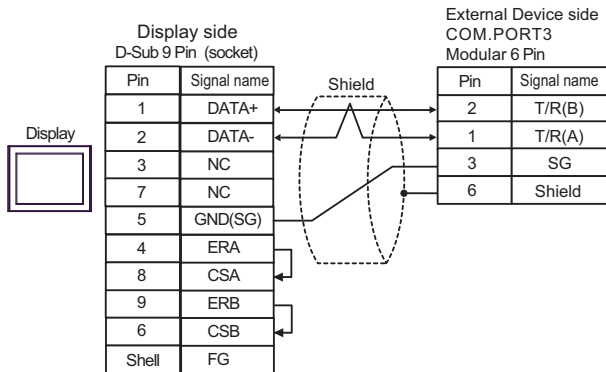

- 1:n Connection

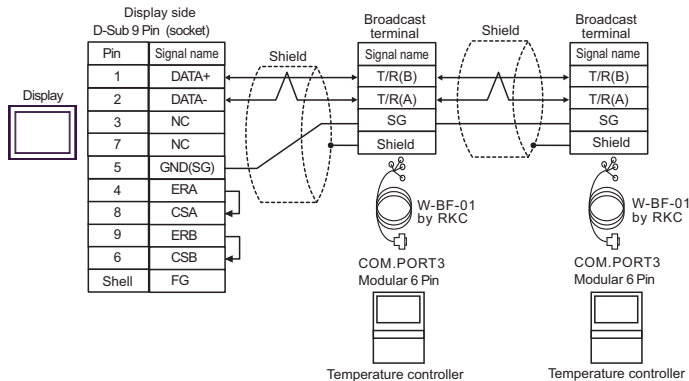

NOTE • Termination resistance is not necessary.

9G)

- 1:1 Connection

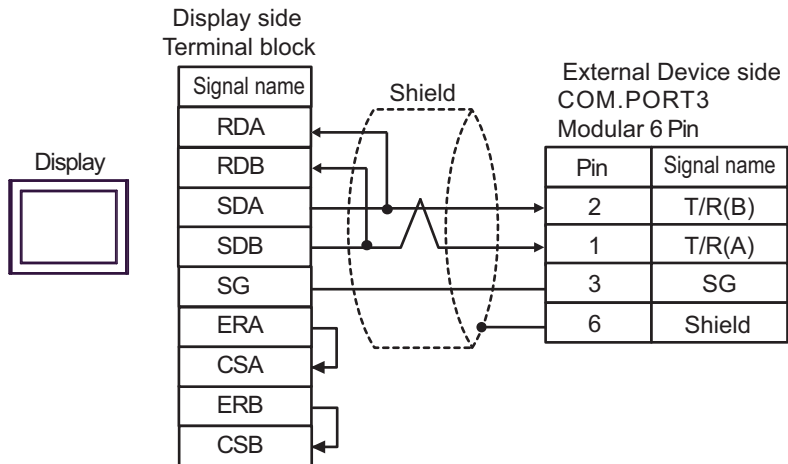

- 1:n Connection

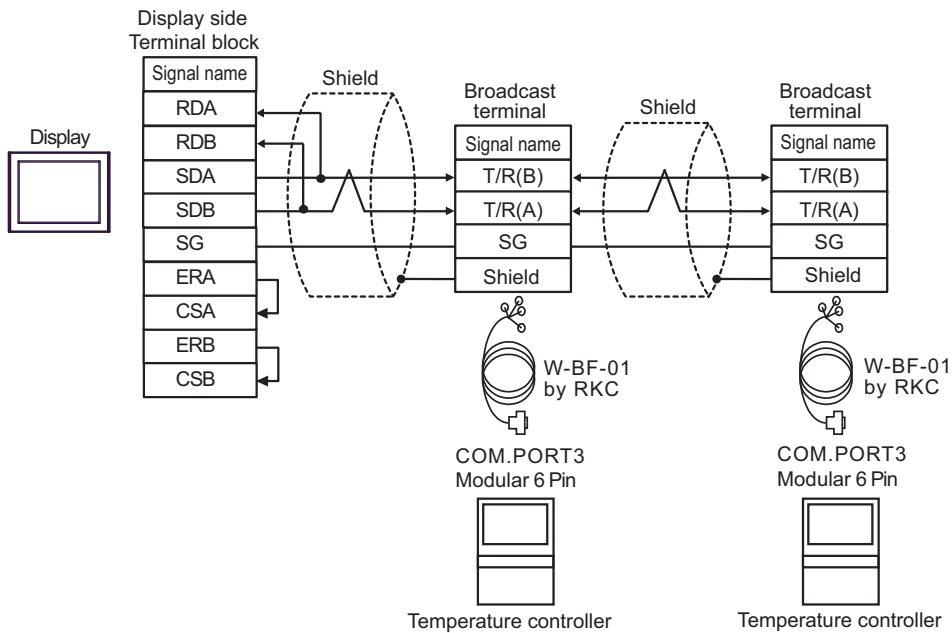

NOTE • Termination resistance is not necessary.

9H)

- 1:1 Connection

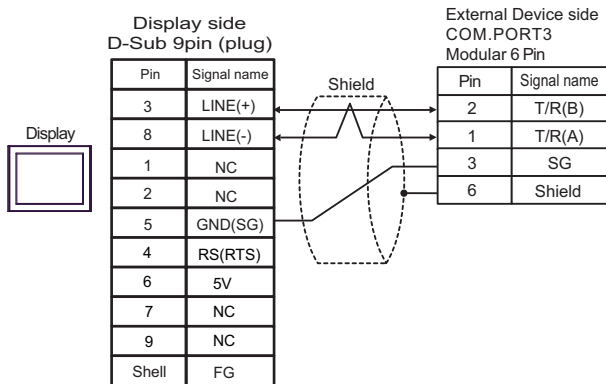

- 1:n Connection

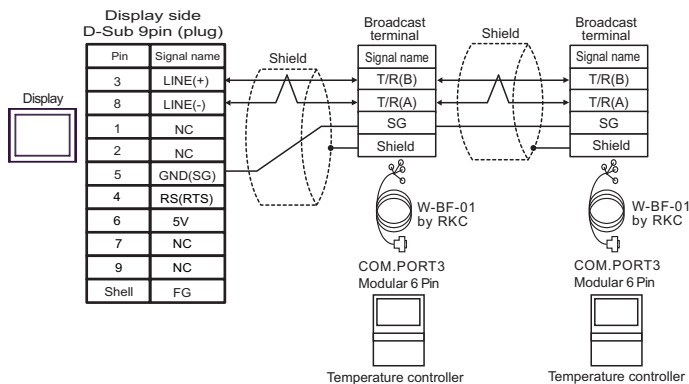

IMPORTANT • The 5V output (Pin #6) on the Display is the power for the Siemens AG's PROFIBUS connector. Do not use it for other devices.

NOTE

- Termination resistance is not necessary.
- In COM on the GP-4107, the SG and FG terminals are isolated.

9I)

- 1:1 Connection

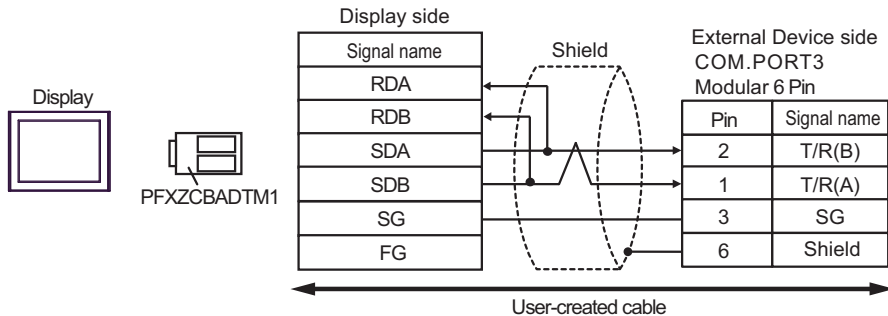

- 1: n connection

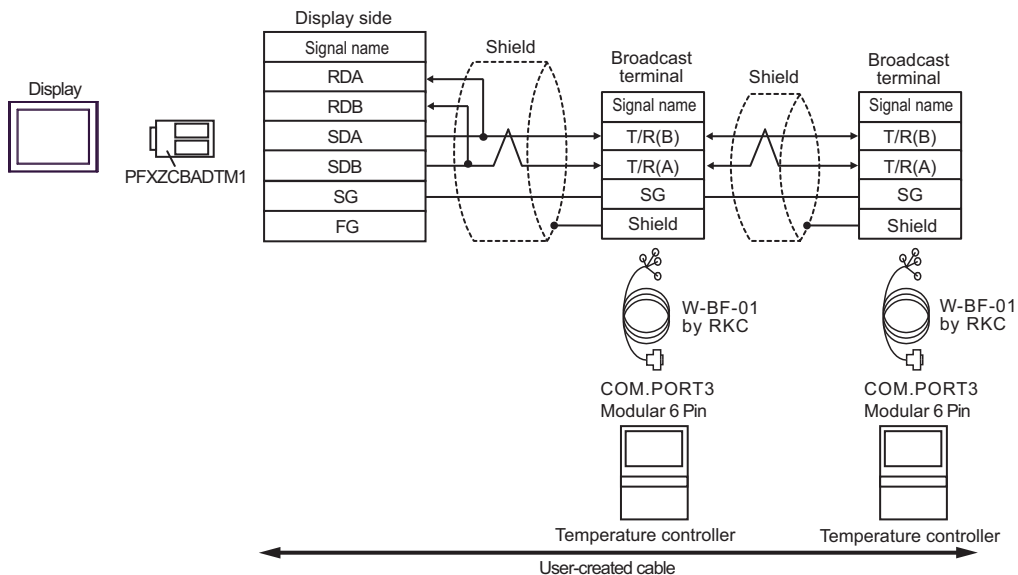

NOTE • Termination resistance is not necessary.

9J)

- 1:1 Connection

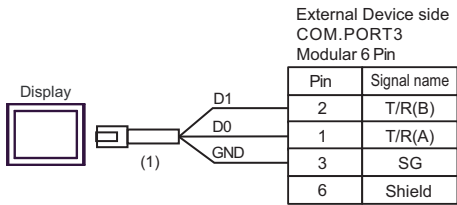

- 1:n Connection

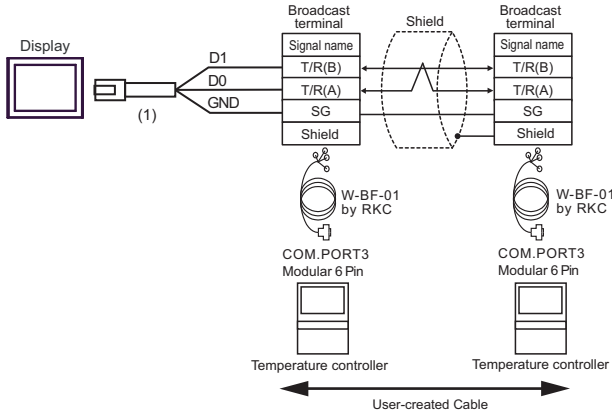

NOTE • Termination resistance is not necessary.

Number	Name	Notes
(1)	RJ45 RS-485 Cable (5m) by Pro-face PFXZLMCBJR81	

9K)

- 1:1 Connection

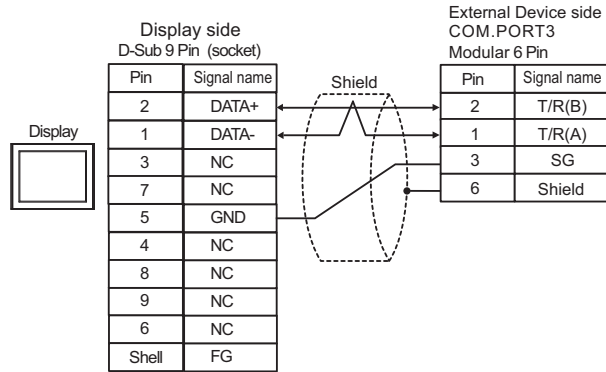

- 1:n Connection

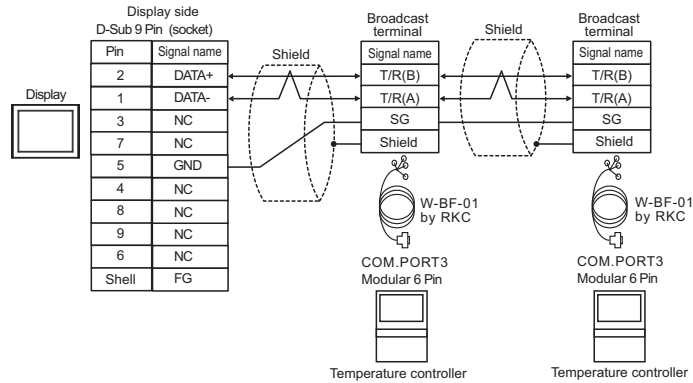

NOTE • Termination resistance is not necessary.

Cable Diagram 10

Display (Connection Port)	Cable		Remarks
GP3000* ¹ (COM1) AGP-3302B (COM2) GP-4*01TM (COM1) GP-Rear Module (COM1) ST3000* ² (COM2) LT3000 (COM1)	10A	COM port conversion adapter by Pro-face CA3-ADPCOM-01 + Terminal block conversion adapter by Pro-face CA3-ADPTRM-01 + User-created cable	Cable length: 1200m or less
	10B	User-created cable	
GP3000* ³ (COM2)	10C	Online adapter by Pro-face CA4-ADPONL-01 + Terminal block conversion adapter by Pro-face CA3-ADPTRM-01 + User-created cable	Cable length: 1200m or less
	10D	Online adapter by Pro-face CA4-ADPONL-01 + User-created cable	
IPC* ⁴	10E	COM port conversion adapter by Pro-face CA3-ADPCOM-01 + Terminal block conversion adapter by Pro-face CA3-ADPTRM-01 + User-created cable	Cable length: 1200m or less
	10F	User-created cable	
GP-4106 (COM1) GP-4116T (COM1)	10G	User-created cable	Cable length: 1200m or less
GP-4107 (COM1) GP-4*03T* ⁵ (COM2) GP-4203T (COM1)	10H	User-created cable	Cable length: 1200m or less
GP4000* ⁶ (COM2) GP-4201T (COM1) SP5000* ⁷ (COM1/2) SP-5B00 (COM2) ST6000* ⁸ (COM2) ST-6200 (COM1) STM6000 (COM1) STC6000 (COM1) ET6000* ⁹ (COM2) PS6000 (Basic Box) (COM1/2)	10I	RS-422 terminal block conversion adapter by Pro-face PFXZCBADTM1* ¹⁰ + User-created cable	Cable length: 1200m or less
	10B	User-created cable	
LT-4*01TM (COM1) LT-Rear Module (COM1)	10J	RJ45 RS-485 Cable (5m) by Pro-face PFXZLMCBJR81	Cable length: 200m or less
PE-4000B* ¹¹ PS5000* ¹¹ PS6000 (Optional Interface)* ¹¹	10K	User-created cable	Cable length: 1200m or less

*1 All GP3000 models except AGP-3302B

- *2 Except AST-3211A and AST-3302B
- *3 All GP3000 models except GP-3200 and AGP-3302B
- *4 Only the COM port which can communicate by RS-422/485 (2wire) can be used. (Except PE-4000B, PS5000, and PS6000)
 - ☞ ■ IPC COM Port (page 7)
- *5 Except GP-4203T
- *6 All GP4000 models except GP-4100 series, GP-4*01TM, GP-Rear Module, GP-4201T and GP-4*03T
- *7 Except SP-5B00
- *8 Except ST-6200
- *9 Due to the COM port specifications, flow control is not possible. Omit wiring the control pins on the Display side of the cable diagram.
- *10 When using a Terminal Block Conversion Adapter (CA3-ADPTRM-01) instead of the RS-422 Terminal Block Conversion Adapter, refer to Cable Diagram 10A.
- *11 Only the COM port which can communicate by RS-422/485 (2wire) can be used.
 - ☞ ■ IPC COM Port (page 7)

10A)

- 1:1 Connection

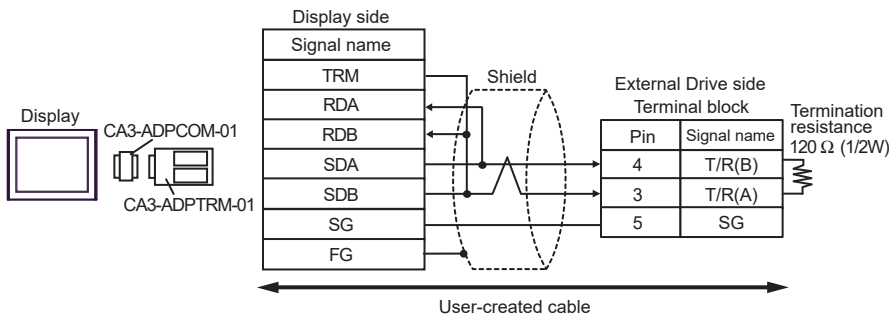

- 1:n Connection (When connecting with the internal communication line)

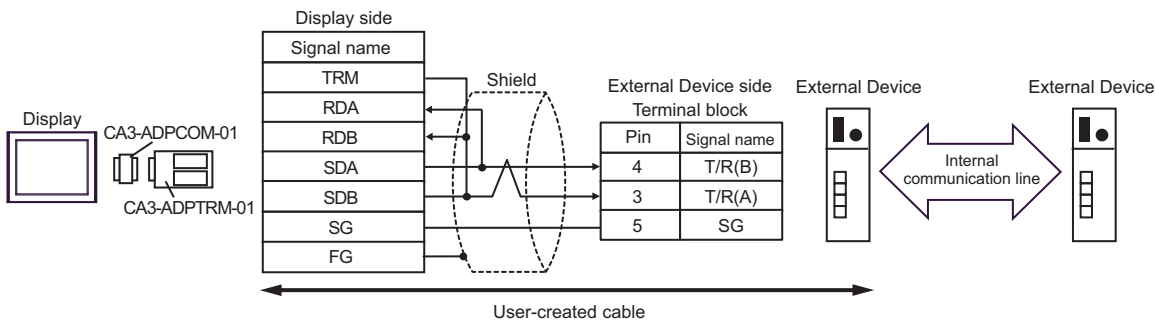

- 1:n Connection

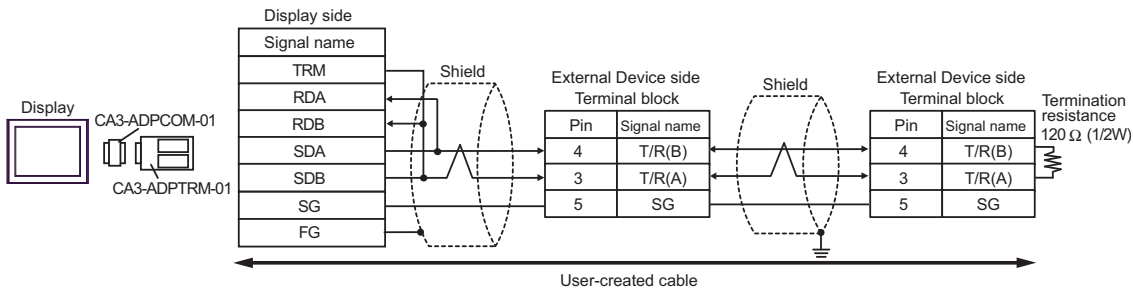

10B)

- 1:1 Connection

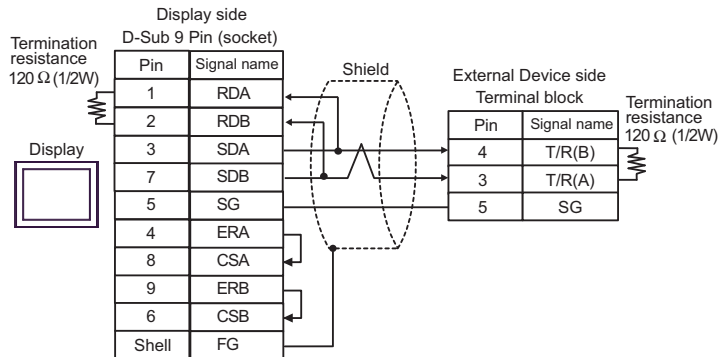

- 1:n Connection (When connecting with the internal communication line)

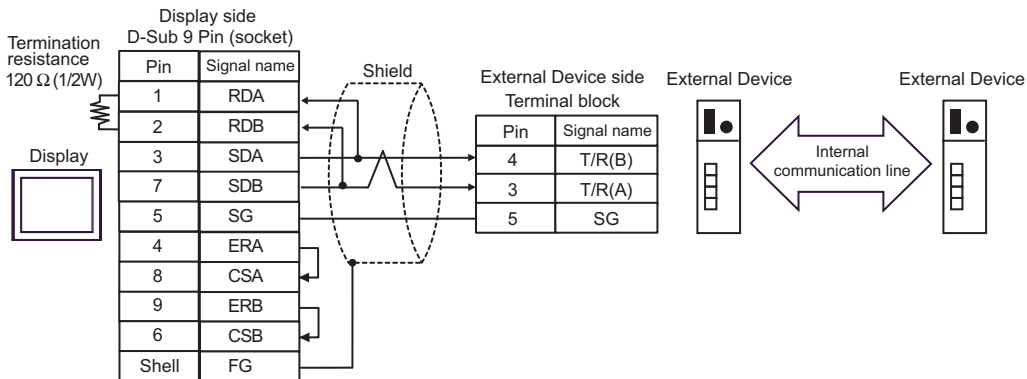

- 1:n Connection

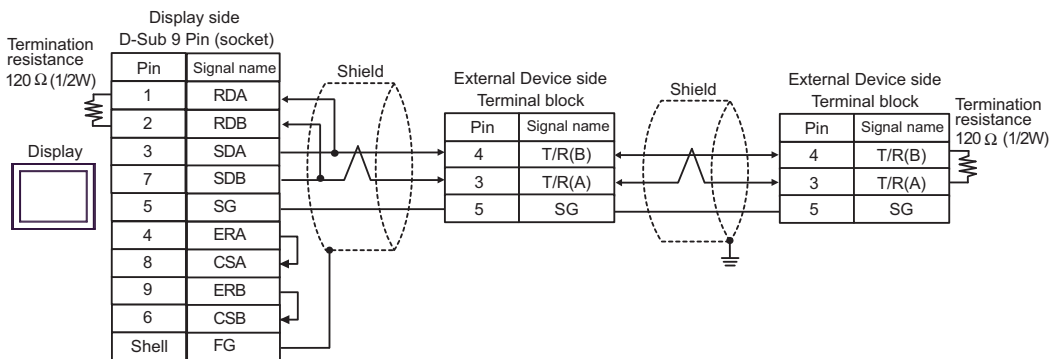

10C)

- 1:1 Connection

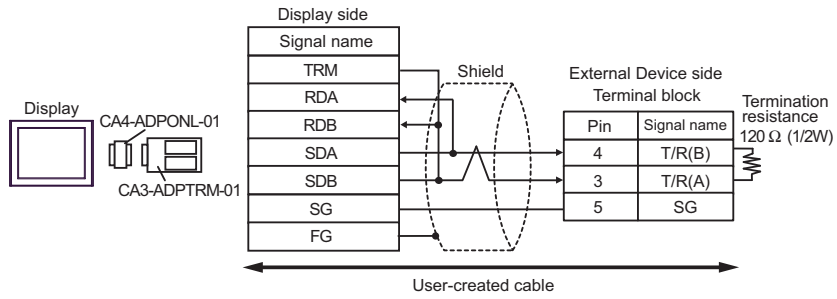

- 1:n Connection (When connecting with the internal communication line)

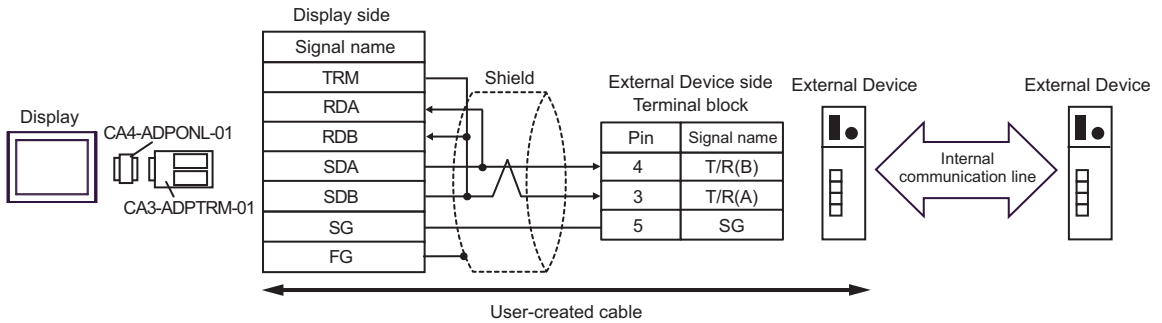

- 1:n Connection

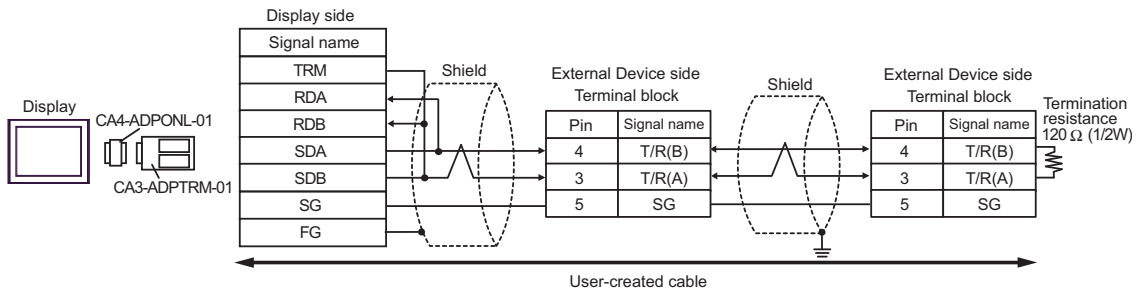

10D)

- 1:1 Connection

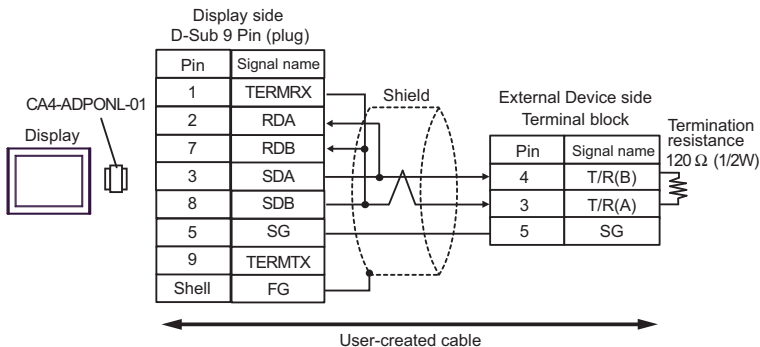

- 1:n Connection (When connecting with the internal communication line)

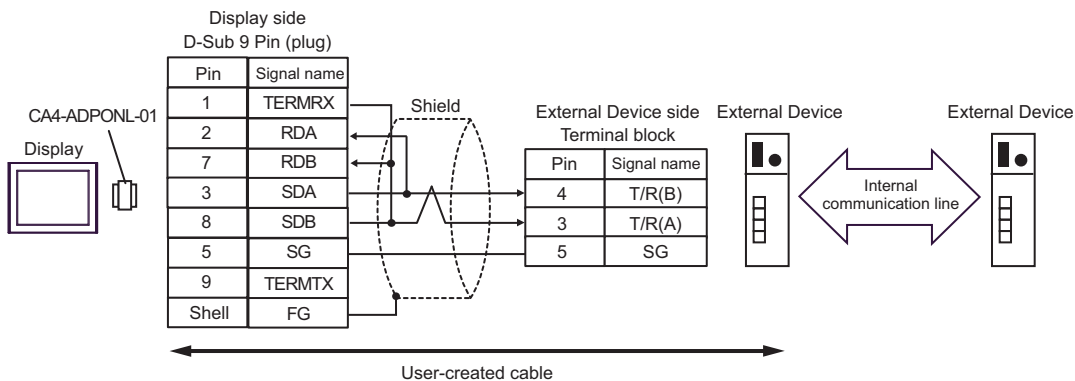

- 1:n Connection

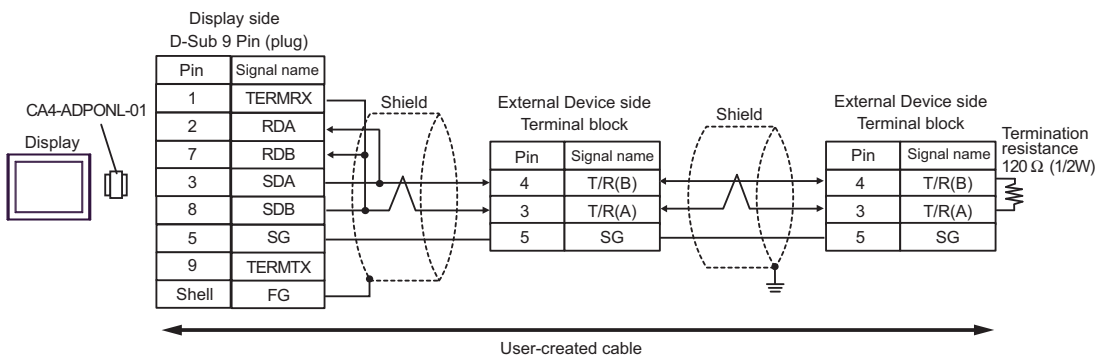

10E)

- 1:1 Connection

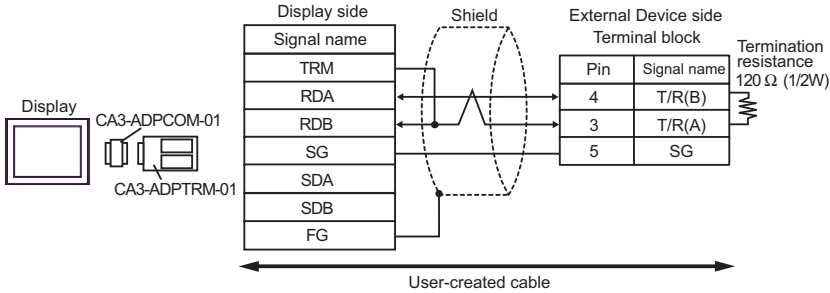

- 1:n Connection (When connecting with the internal communication line)

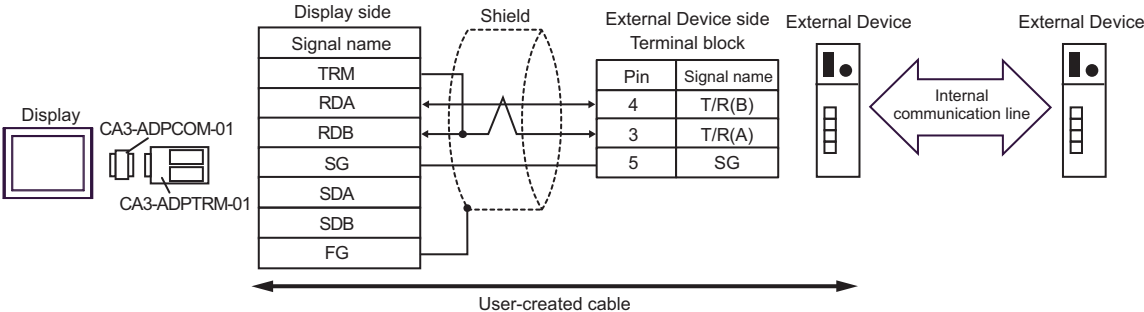

- 1:n Connection

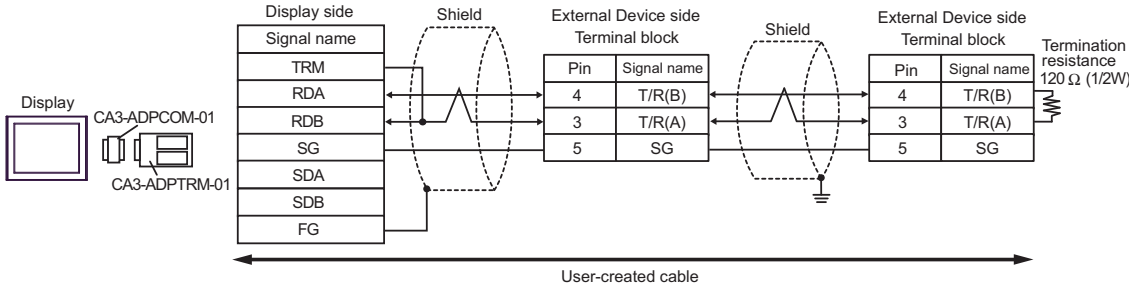

10F)

- 1:1 Connection

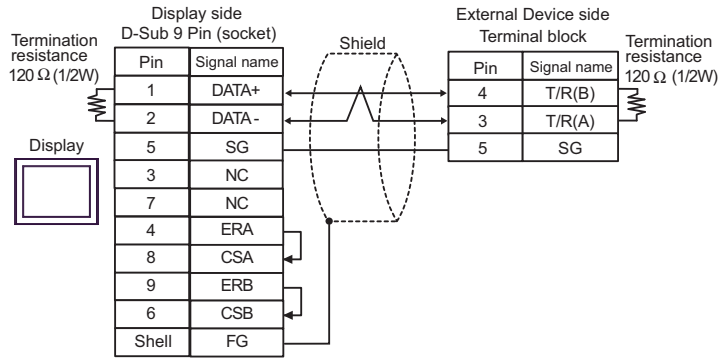

- 1:n Connection (When connecting with the internal communication line)

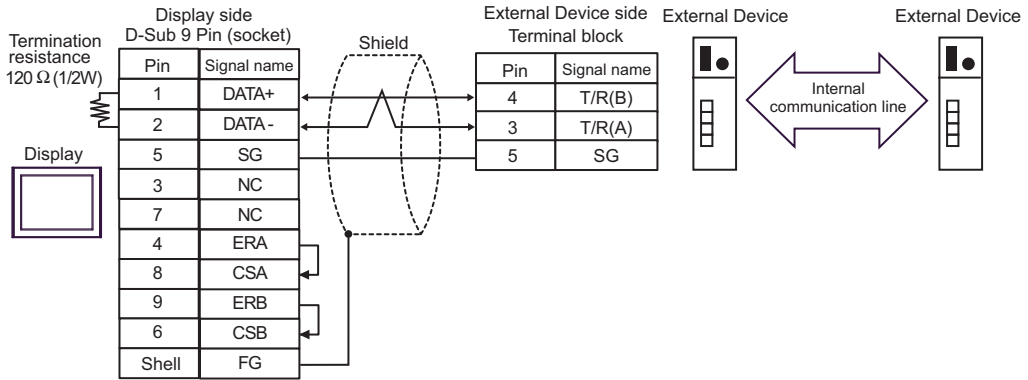

- 1:n Connection

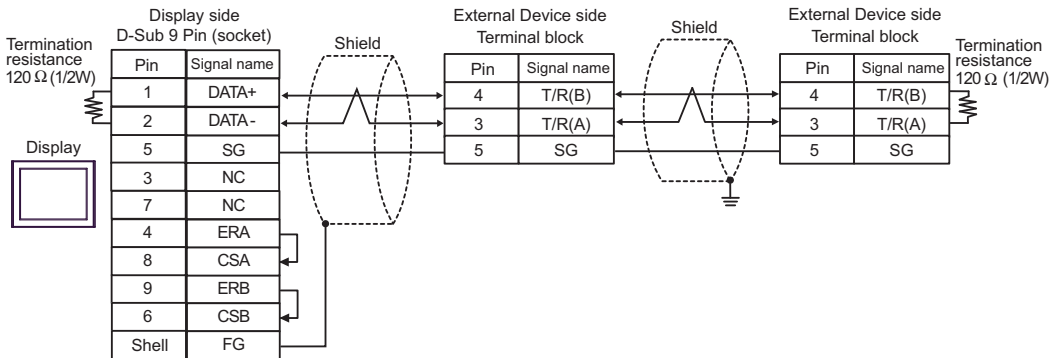

10G)

- 1:1 Connection

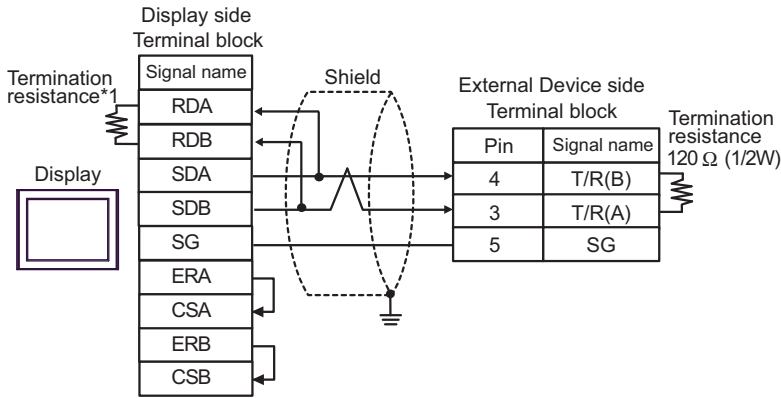

- 1:n Connection (When connecting with the internal communication line)

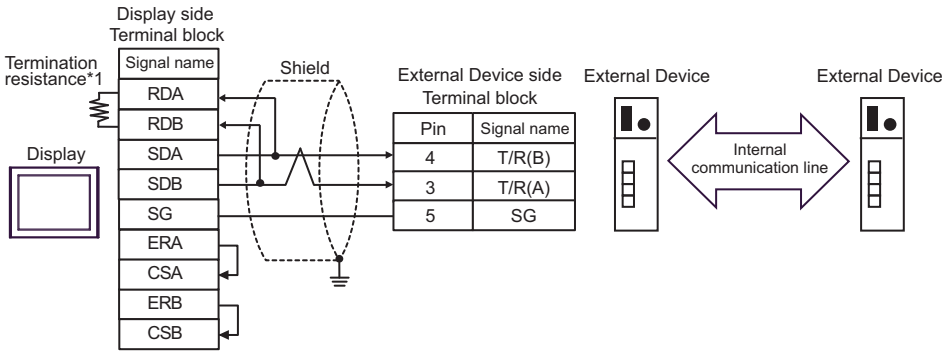

- 1:n Connection

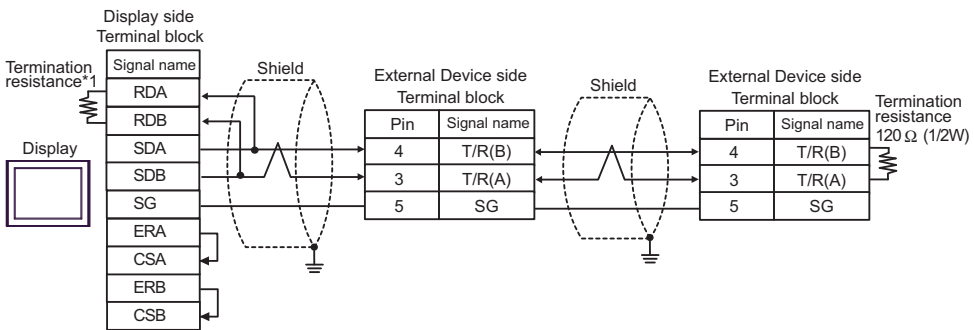

*1 The resistance in the Display is used as the termination resistance. Set the value of the DIP Switch on the rear of the Display as shown in the table below.

DIP Switch No.	Set Value
1	OFF
2	OFF
3	ON
4	ON

10H)

- 1:1 Connection

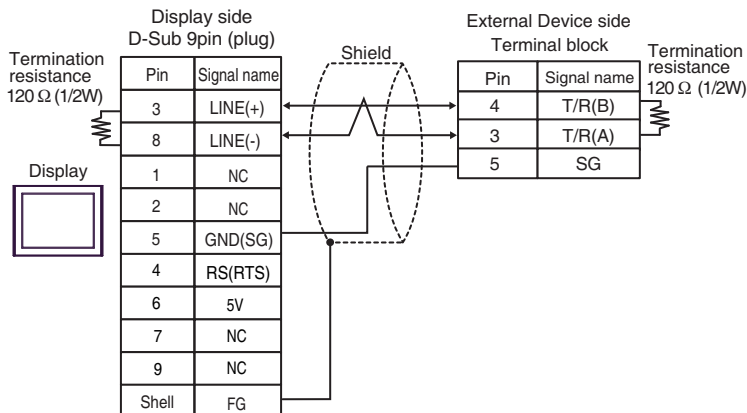

- 1:n Connection (When connecting with the internal communication line)

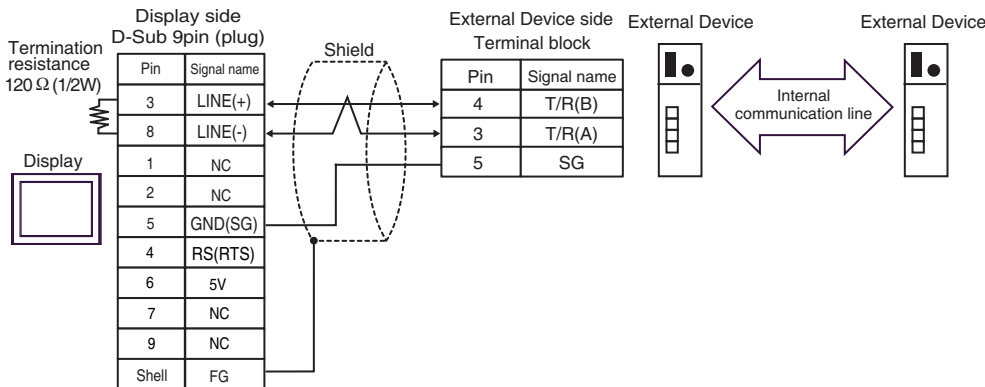

- 1:n Connection

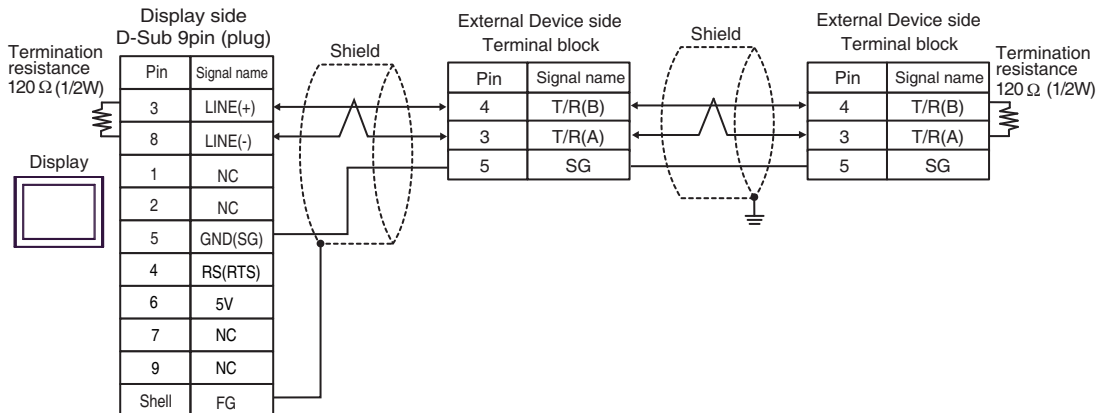

IMPORTANT • The 5V output (Pin #6) on the Display is the power for the Siemens AG's PROFIBUS connector. Do not use it for other devices.

NOTE • In COM on the GP-4107, the SG and FG terminals are isolated.

10I)

- 1:1 Connection

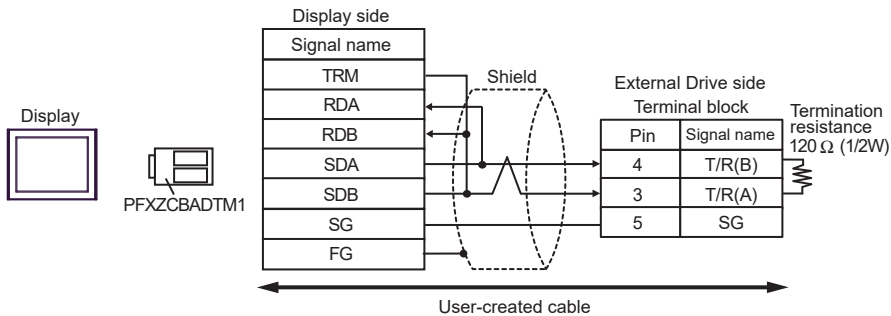

- 1:n Connection (When connecting with the internal communication line)

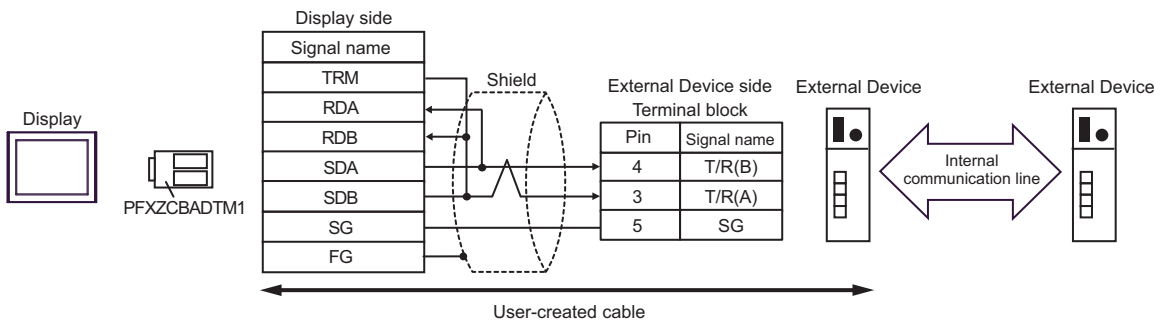

- 1:n Connection

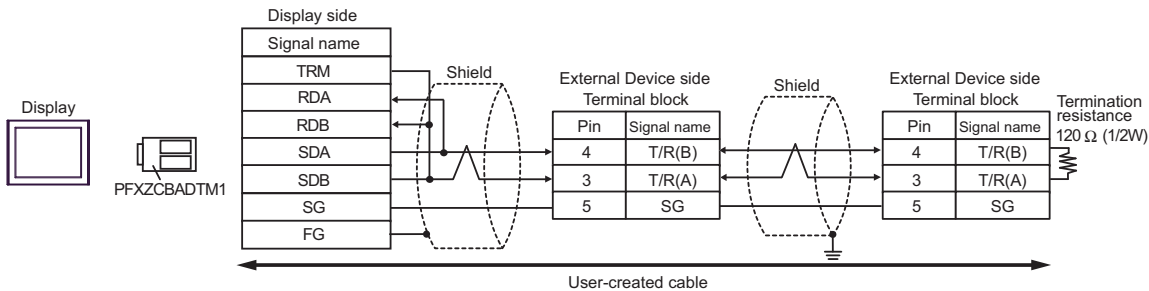

10J)

- 1:1 Connection

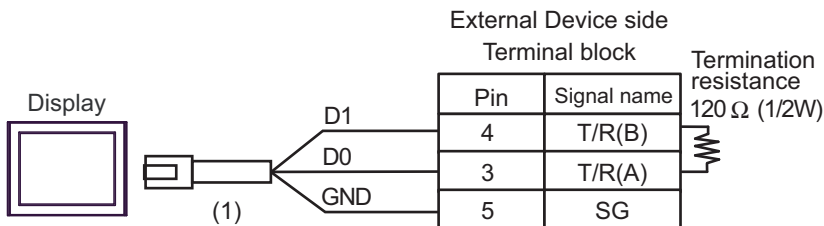

- 1:n Connection (When connecting with the internal communication line)

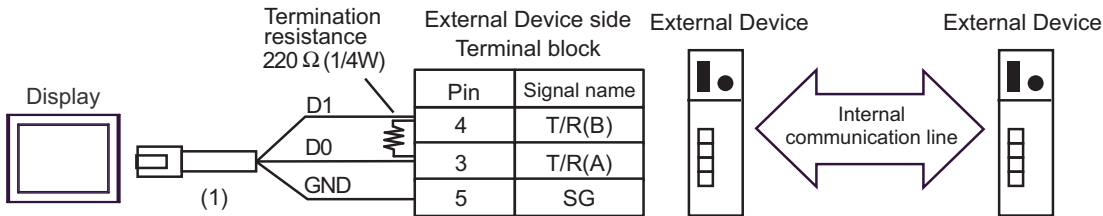

- 1:n Connection

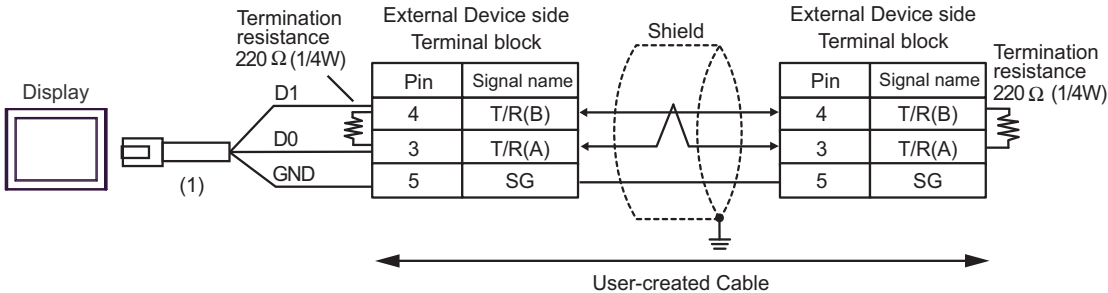

Number	Name	Notes
(1)	RJ45 RS-485 Cable (5m) by Pro-face PFXZLMCBJR81	

10K)

- 1:1 Connection

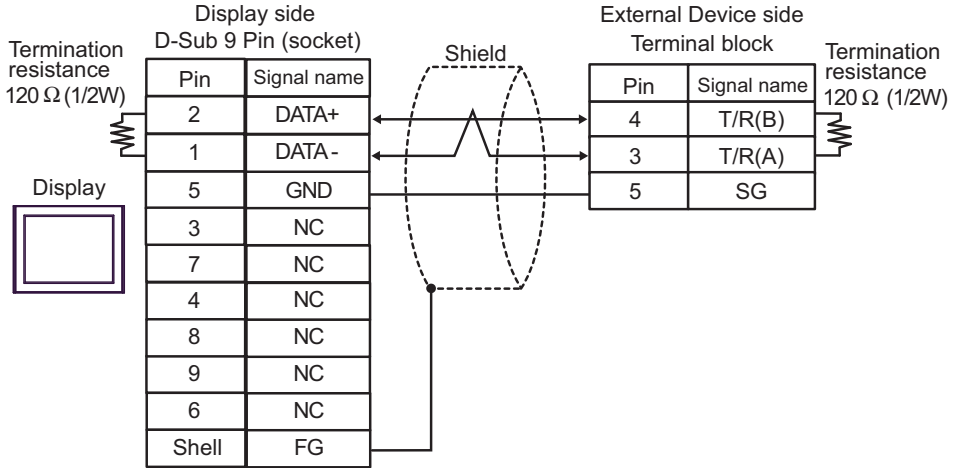

- 1:n Connection (When connecting with the internal communication line)

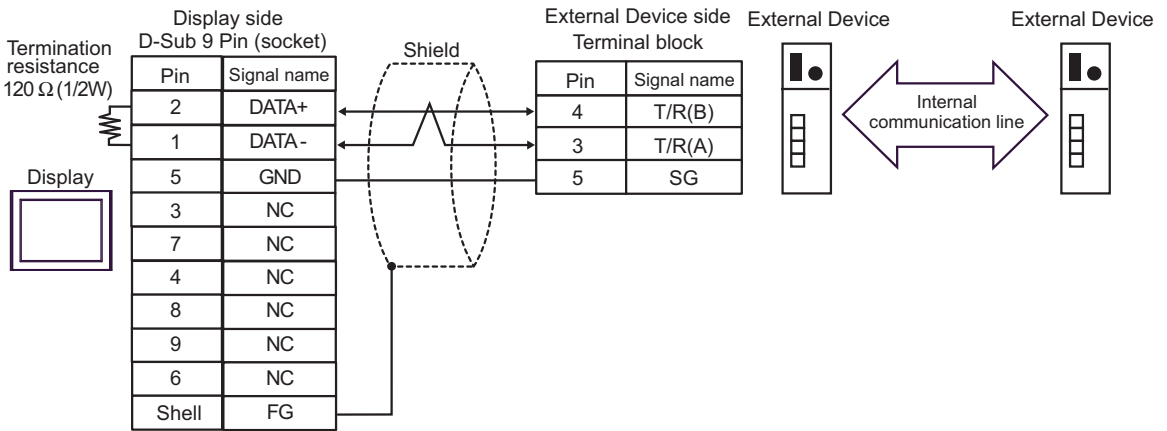

- 1:n Connection

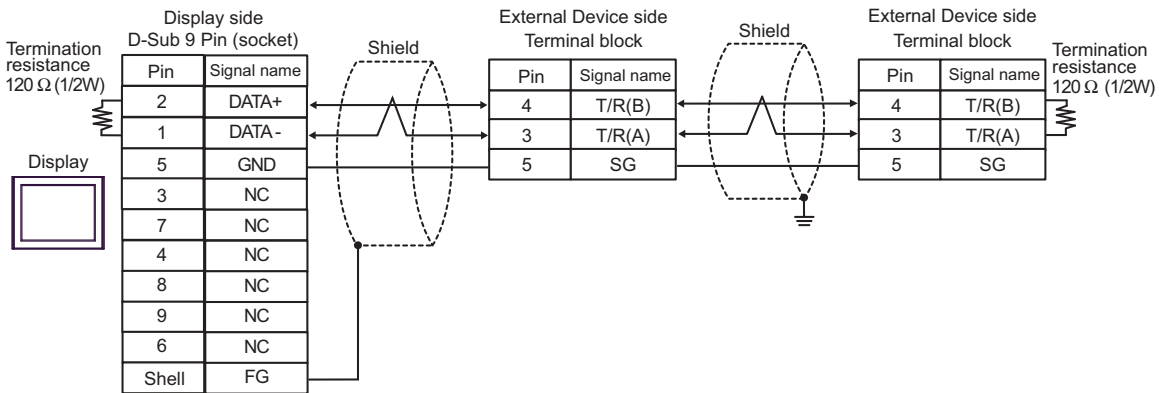

Cable Diagram 11

Display (Connection Port)	Cable		Remarks
GP3000* ¹ (COM1) AGP-3302B (COM2) GP-4*01TM (COM1) GP-Rear Module (COM1) ST3000* ² (COM2) LT3000 (COM1) IPC* ³	11A	COM port conversion adapter by Pro-face CA3-ADPCOM-01 + Terminal block conversion adapter by Pro-face CA3-ADPTRM-01 + User-created cable + Connector cable from RKC INSTRUMENT INC.* ⁵ W-BF-02	Cable length: 1200m or less
	11B	User-created cable + Connector cable from RKC INSTRUMENT INC.* ⁵ W-BF-02	
GP3000* ⁴ (COM2)	11C	Online adapter by Pro-face CA4-ADPONL-01 + Terminal block conversion adapter by Pro-face CA3-ADPTRM-01 + User-created cable + Connector cable from RKC INSTRUMENT INC.* ⁵ W-BF-02	Cable length: 1200m or less
	11D	Online adapter by Pro-face CA4-ADPONL-01 + User-created cable + Connector cable from RKC INSTRUMENT INC.* ⁵ W-BF-02	
GP-4106 (COM1) GP-4116T (COM1)	11E	User-created cable + Connector cable from RKC INSTRUMENT INC.* ⁵ W-BF-02	Cable length: 1200m or less
GP4000* ⁶ (COM2) GP-4201T (COM1) SP5000* ⁷ (COM1/2) SP-5B00 (COM2) ST6000* ⁸ (COM2) ST-6200 (COM1) STM6000 (COM1) STC6000 (COM1) ET6000* ⁹ (COM2) PS6000 (Basic Box) (COM1/2)	11F	RS-422 terminal block conversion adapter by Pro-face PFXZCBADTM1* ¹⁰ + User-created cable + Connector cable from RKC INSTRUMENT INC.* ⁵ W-BF-02	Cable length: 1200m or less
	11B	User-created cable + Connector cable from RKC INSTRUMENT INC.* ⁵ W-BF-02	

Display (Connection Port)	Cable		Remarks
PE-4000B ^{*11} PS5000 ^{*11} PS6000 (Optional Interface) ^{*11}	11G	User-created cable + Connector cable from RKC INSTRUMENT INC. ^{*5} W-BF-02	Cable length: 1200m or less

*1 All GP3000 models except AGP-3302B

*2 Except AST-3211A and AST-3302B

*3 Only the COM port which can communicate by RS-422/485 (4wire) can be used. (Except PE-4000B, PS5000, and PS6000)

 ■ IPC COM Port (page 7)

*4 All GP3000 models except GP-3200 and AGP-3302B

*5 To use multiple External Devices, utilize the W-BF-02 connector cable from RKC INSTRUMENT INC.

*6 All GP4000 models except GP-4100 series, GP-4*01TM, GP-Rear Module, GP-4201T and GP-4*03T

*7 Except SP-5B00

*8 Except ST-6200

*9 Due to the COM port specifications, flow control is not possible. Omit wiring the control pins on the Display side of the cable diagram.

*10 When using a Terminal Block Conversion Adapter (CA3-ADPTRM-01) instead of the RS-422 Terminal Block Conversion Adapter, refer to Cable Diagram 11A.

*11 Only the COM port which can communicate by RS-422/485 (4wire) can be used.

 ■ IPC COM Port (page 7)

11A)

- 1:1 Connection

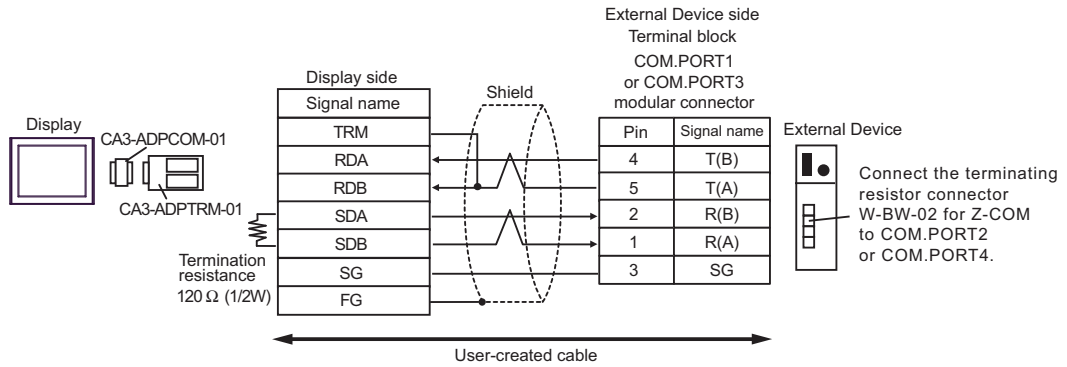

- 1:n Connection

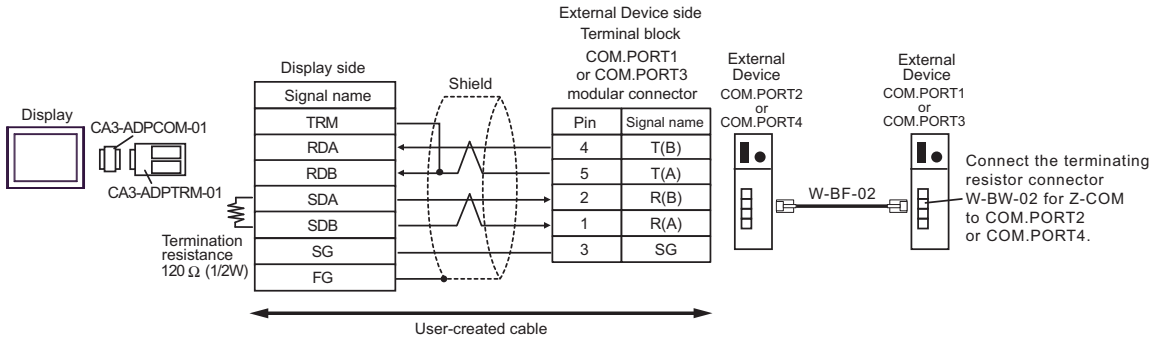

NOTE

- We recommend the TM4P-66P from HIROSE ELECTRIC CO., LTD. as the modular connector.
- To use the External Device's COM.PORT, pair COM.PORT1 with COM.PORT2, and COM.PORT3 with COM.PORT4.

11B)

- 1:1 Connection

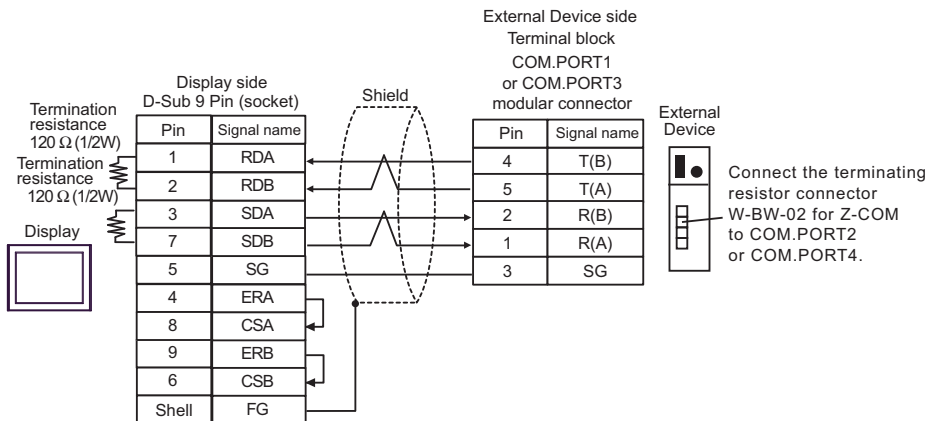

- 1:n Connection

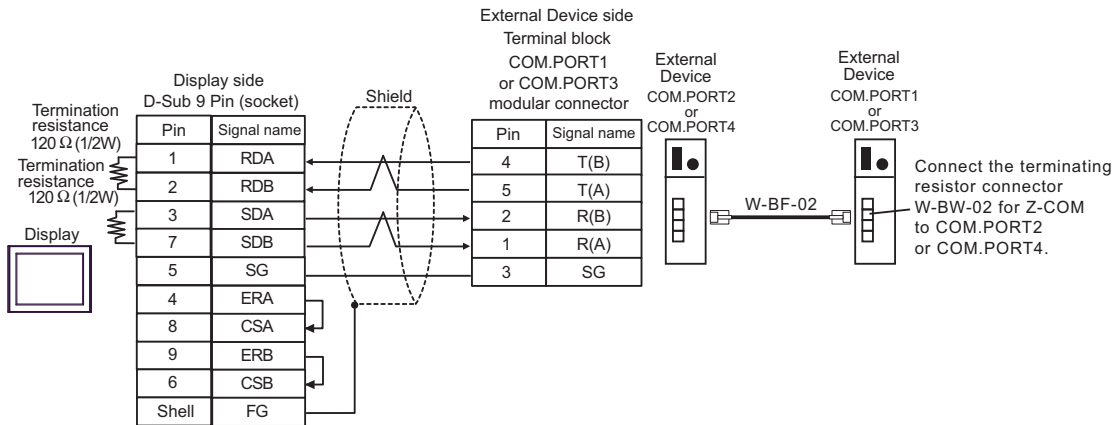

NOTE

- We recommend the TM4P-66P from HIROSE ELECTRIC CO., LTD. as the modular connector.
- To use the External Device's COM.PORT, pair COM.PORT1 with COM.PORT2, and COM.PORT3 with COM.PORT4.

11C)

- 1:1 Connection

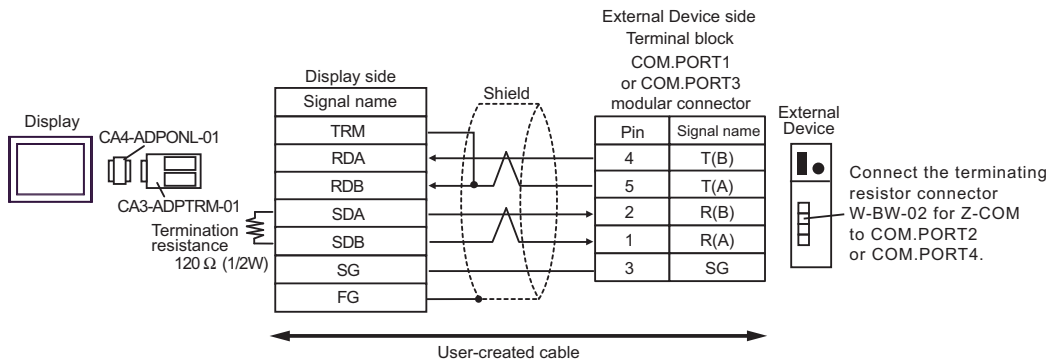

- 1:n Connection

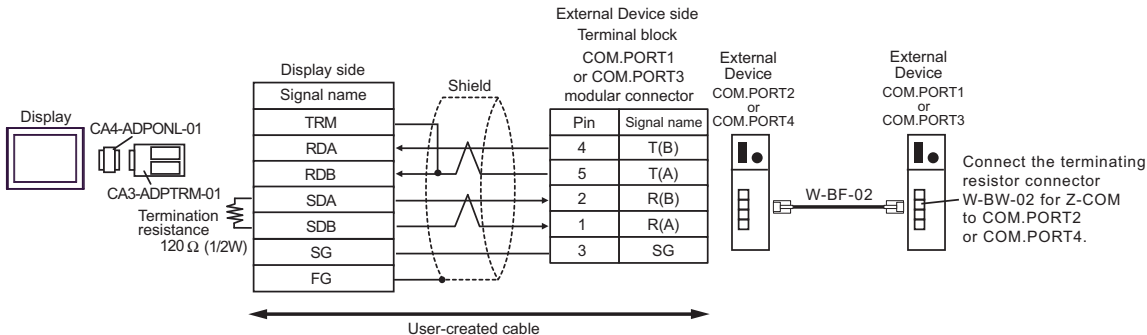

NOTE

- We recommend the TM4P-66P from HIROSE ELECTRIC CO., LTD. as the modular connector.
- To use the External Device's COM.PORT, pair COM.PORT1 with COM.PORT2, and COM.PORT3 with COM.PORT4.

11D)

- 1:1 Connection

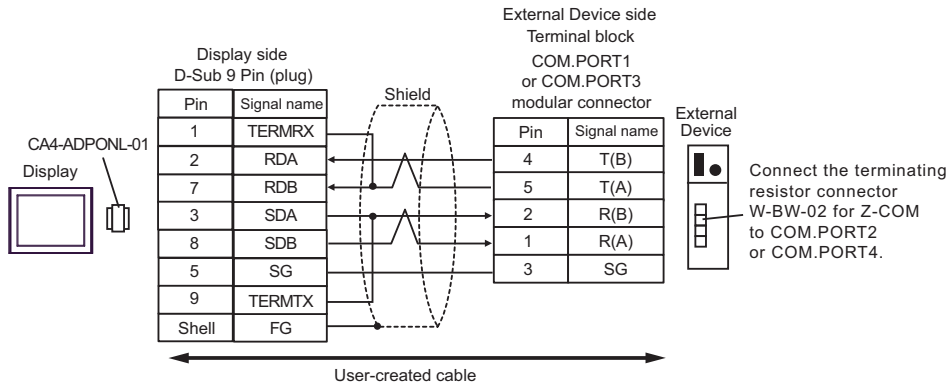

- 1:n Connection

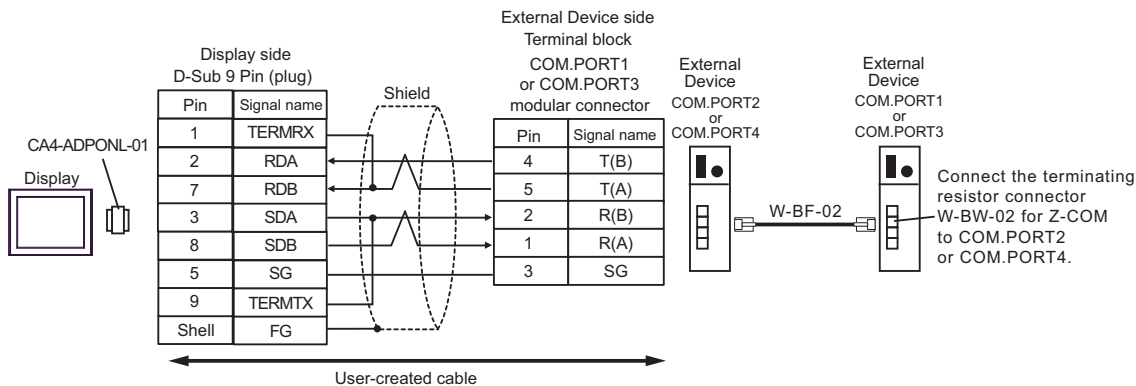

NOTE

- We recommend the TM4P-66P from HIROSE ELECTRIC CO., LTD. as the modular connector.
- To use the External Device's COM.PORT, pair COM.PORT1 with COM.PORT2, and COM.PORT3 with COM.PORT4.

11E)

- 1:1 Connection

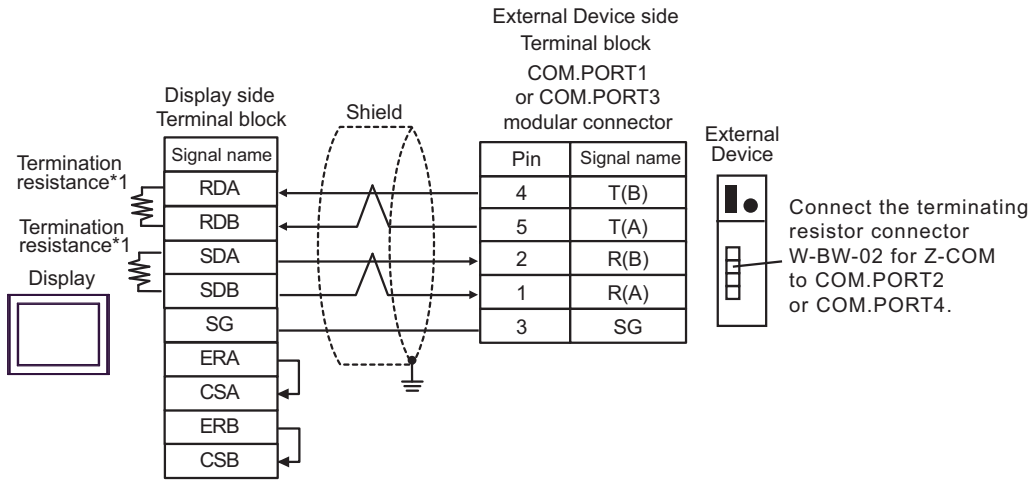

- 1:n Connection

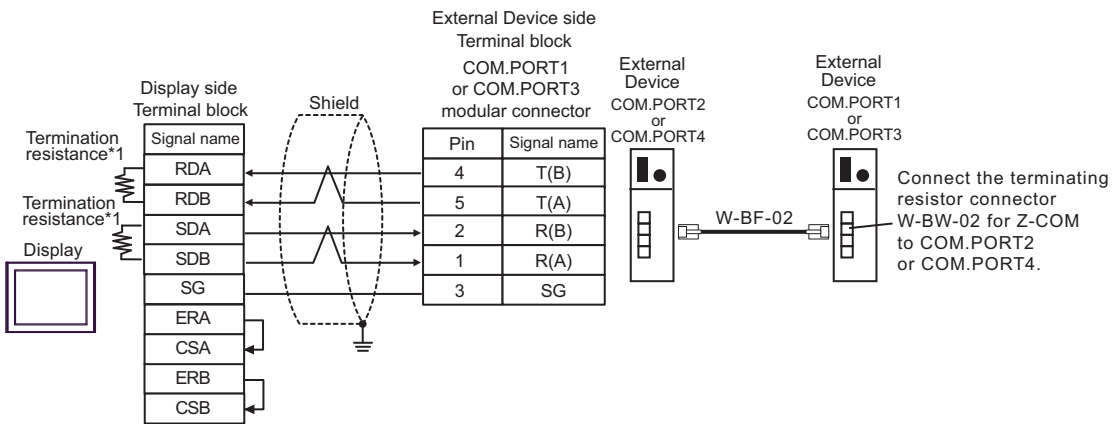

NOTE

- We recommend the TM4P-66P from HIROSE ELECTRIC CO., LTD. as the modular connector.
- To use the External Device's COM.PORT, pair COM.PORT1 with COM.PORT2, and COM.PORT3 with COM.PORT4.

*1 The resistance in the Display is used as the termination resistance. Set the value of the DIP Switch on the rear of the Display as shown in the table below.

DIP Switch No.	Set Value
1	ON
2	ON
3	ON
4	ON

11F)

- 1:1 Connection

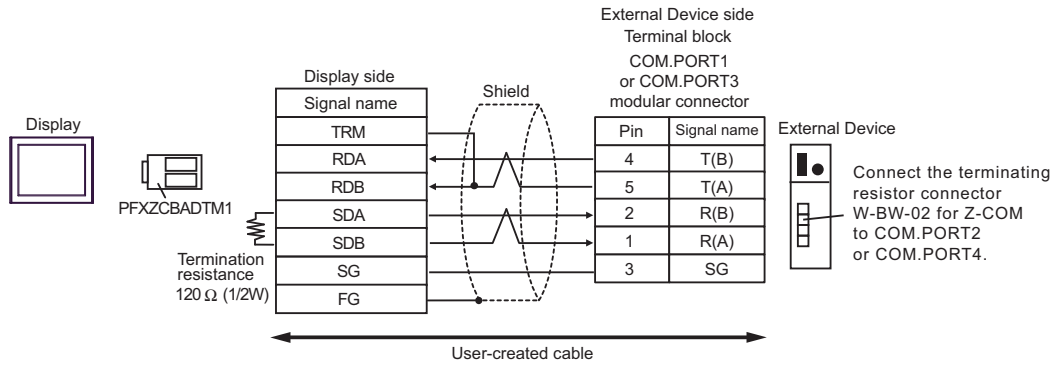

- 1:n Connection

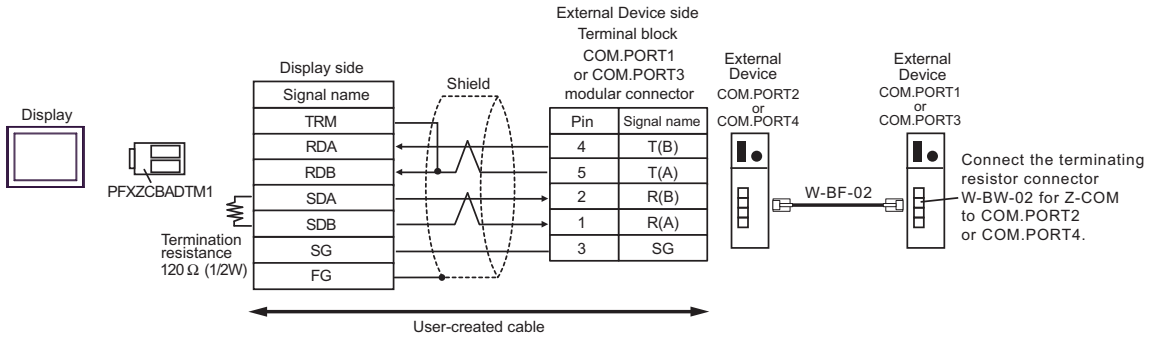

NOTE

- We recommend the TM4P-66P from HIROSE ELECTRIC CO., LTD. as the modular connector.
- To use the External Device's COM.PORT, pair COM.PORT1 with COM.PORT2, and COM.PORT3 with COM.PORT4.

11G)

- 1:1 Connection

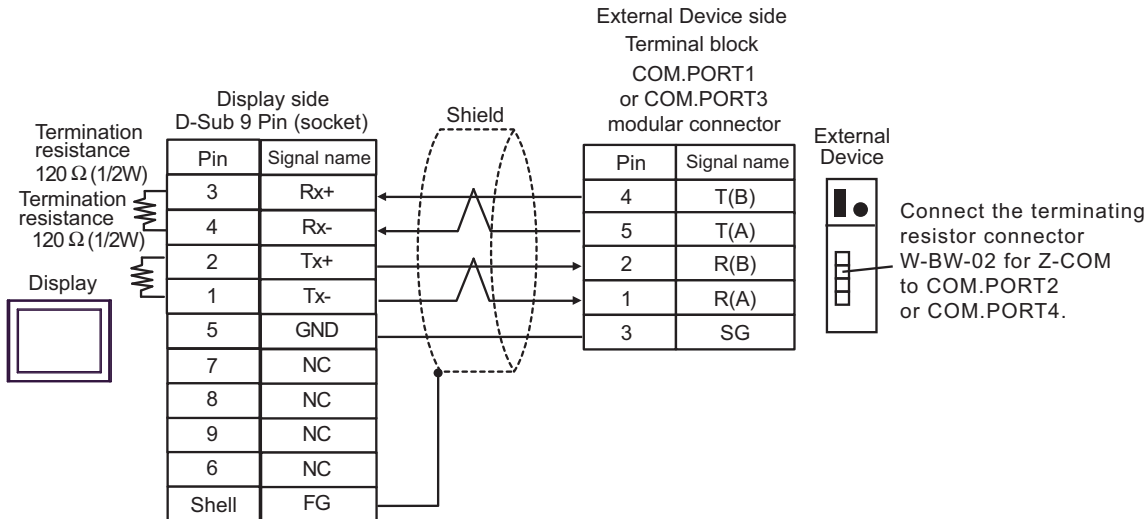

- 1:n Connection

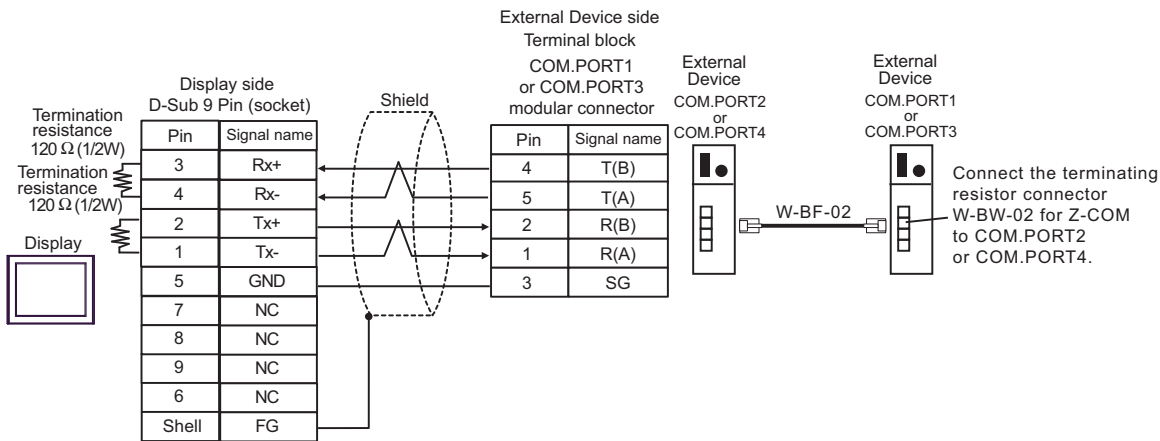

NOTE

- We recommend the TM4P-66P from HIROSE ELECTRIC CO., LTD. as the modular connector.
- To use the External Device's COM.PORT, pair COM.PORT1 with COM.PORT2, and COM.PORT3 with COM.PORT4.

Cable Diagram 12

Display (Connection Port)	Cable		Remarks
GP3000* ¹ (COM1) AGP-3302B (COM2) GP-4*01TM (COM1) GP-Rear Module (COM1) ST3000* ² (COM2) LT3000 (COM1)	12A	COM port conversion adapter by Pro-face CA3-ADPCOM-01 + Terminal block conversion adapter by Pro-face CA3-ADPTRM-01 + User-created cable + Connector cable from RKC INSTRUMENT INC.* ⁵ W-BF-02	Cable length: 1200m or less
	12B	User-created cable + Connector cable from RKC INSTRUMENT INC.* ⁵ W-BF-02	
GP3000* ³ (COM2)	12C	Online adapter by Pro-face CA4-ADPONL-01 + Terminal block conversion adapter by Pro-face CA3-ADPTRM-01 + User-created cable + Connector cable from RKC INSTRUMENT INC.* ⁵ W-BF-02	Cable length: 1200m or less
	12D	Online adapter by Pro-face CA4-ADPONL-01 + User-created cable + Connector cable from RKC INSTRUMENT INC.* ⁵ W-BF-02	
IPC* ⁴	12E	COM port conversion adapter by Pro-face CA3-ADPCOM-01 + Terminal block conversion adapter by Pro-face CA3-ADPTRM-01 + User-created cable + Connector cable from RKC INSTRUMENT INC.* ⁵ W-BF-02	Cable length: 1200m or less
	12F	User-created cable + Connector cable from RKC INSTRUMENT INC.* ⁵ W-BF-02	

Display (Connection Port)	Cable		Remarks
GP-4106 (COM1) GP-4116T (COM1)	12G	User-created cable + Connector cable from RKC INSTRUMENT INC.*5 W-BF-02	Cable length: 1200m or less
GP-4107 (COM1) GP-4*03T*6 (COM2) GP-4203T (COM1)	12H	User-created cable + Connector cable from RKC INSTRUMENT INC.*5 W-BF-02	Cable length: 1200m or less
GP4000*7 (COM2) GP-4201T (COM1) SP5000*8 (COM1/2) SP-5B00 (COM2) ST6000*9 (COM2) ST-6200 (COM1) STM6000 (COM1) STC6000 (COM1) ET6000*10 (COM2) PS6000 (Basic Box) (COM1/2)	12I	RS-422 terminal block conversion adapter by Pro-face PFXZCBADTM1*11 + User-created cable + Connector cable from RKC INSTRUMENT INC.*5 W-BF-02	Cable length: 1200m or less
	12B	User-created cable + Connector cable from RKC INSTRUMENT INC.*5 W-BF-02	
LT-4*01TM (COM1) LT-Rear Module (COM1)	12J	RJ45 RS-485 Cable (5m) by Pro-face PFXZLMCBJR81	Cable length: 200m or less
PE-4000B*12 PS5000*12 PS6000 (Optional Interface)*12	12K	User-created cable + Connector cable from RKC INSTRUMENT INC.*5 W-BF-02	Cable length: 1200m or less

*1 All GP3000 models except AGP-3302B

*2 Except AST-3211A and AST-3302B

*3 All GP3000 models except GP-3200 and AGP-3302B

*4 Only the COM port which can communicate by RS-422/485 (2wire) can be used. (Except PE-4000B, PS5000, and PS6000)

 ■ IPC COM Port (page 7)

*5 To use multiple External Devices, utilize the W-BF-02 connector cable from RKC INSTRUMENT INC.

*6 Except GP-4203T

*7 All GP4000 models except GP-4100 series, GP-4*01TM, GP-Rear Module, GP-4201T and GP-4*03T

*8 Except SP-5B00

*9 Except ST-6200

*10 Due to the COM port specifications, flow control is not possible. Omit wiring the control pins on the Display side of the cable diagram.

*11 When using a Terminal Block Conversion Adapter (CA3-ADPTRM-01) instead of the RS-422 Terminal Block Conversion Adapter, refer to Cable Diagram 12A.

*12 Only the COM port which can communicate by RS-422/485 (2wire) can be used.

 ■ IPC COM Port (page 7)

12A)

- 1:1 Connection

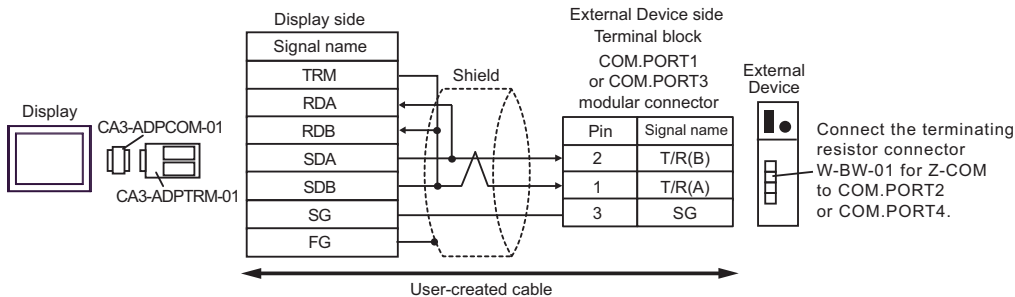

- 1:n Connection

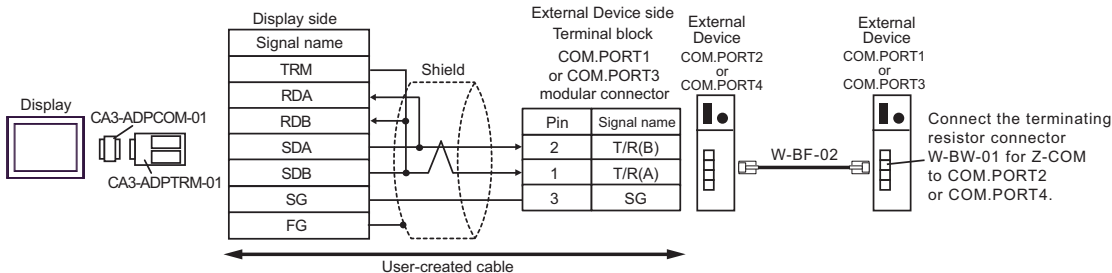

NOTE

- We recommend the TM4P-66P from HIROSE ELECTRIC CO., LTD. as the modular connector.
- To use the External Device's COM.PORT, pair COM.PORT1 with COM.PORT2, and COM.PORT3 with COM.PORT4.

12B)

• 1:1 Connection

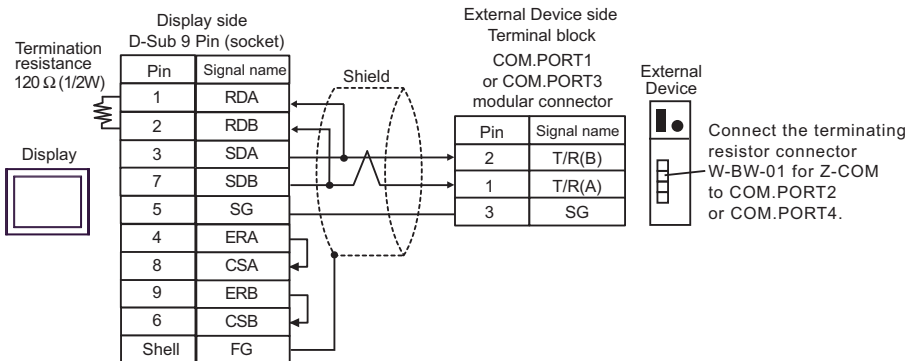

• 1:n Connection

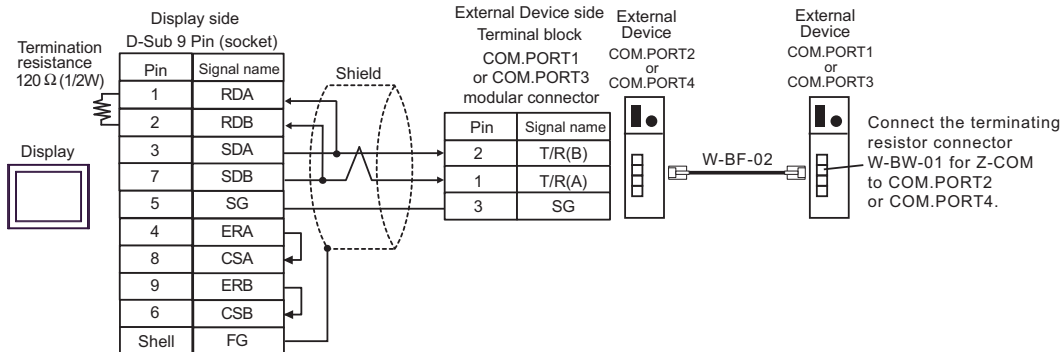

NOTE

- We recommend the TM4P-66P from HIROSE ELECTRIC CO., LTD. as the modular connector.
- To use the External Device's COM.PORT, pair COM.PORT1 with COM.PORT2, and COM.PORT3 with COM.PORT4.

12C)

- 1:1 Connection

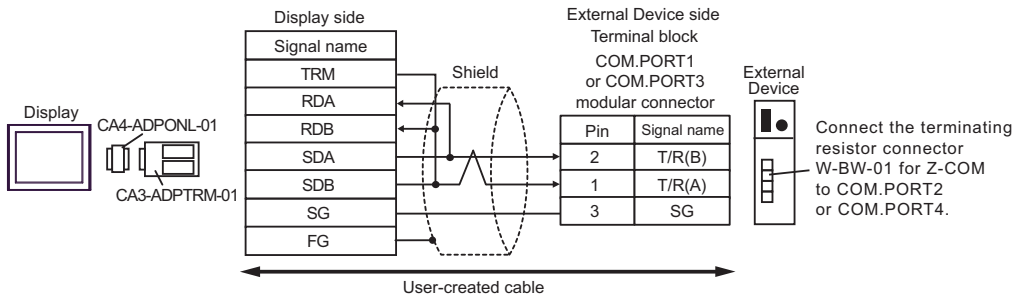

- 1:n Connection

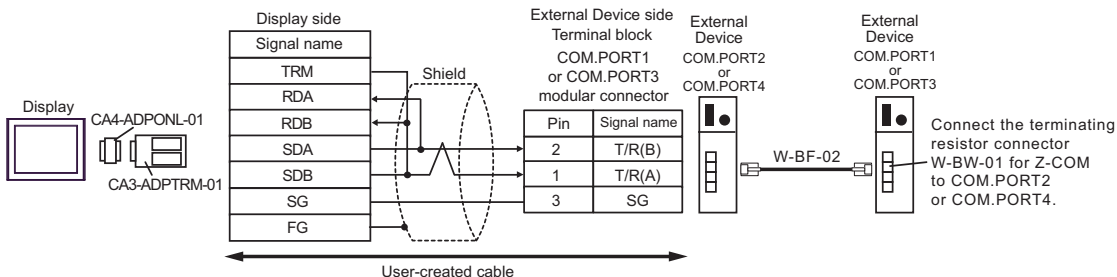

NOTE

- We recommend the TM4P-66P from HIROSE ELECTRIC CO., LTD. as the modular connector.
- To use the External Device's COM.PORT, pair COM.PORT1 with COM.PORT2, and COM.PORT3 with COM.PORT4.

12D)

• 1:1 Connection

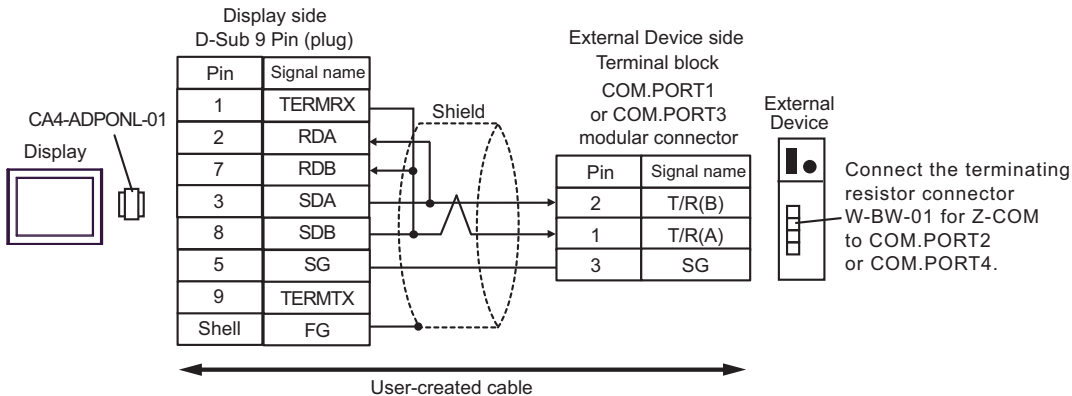

• 1:n Connection

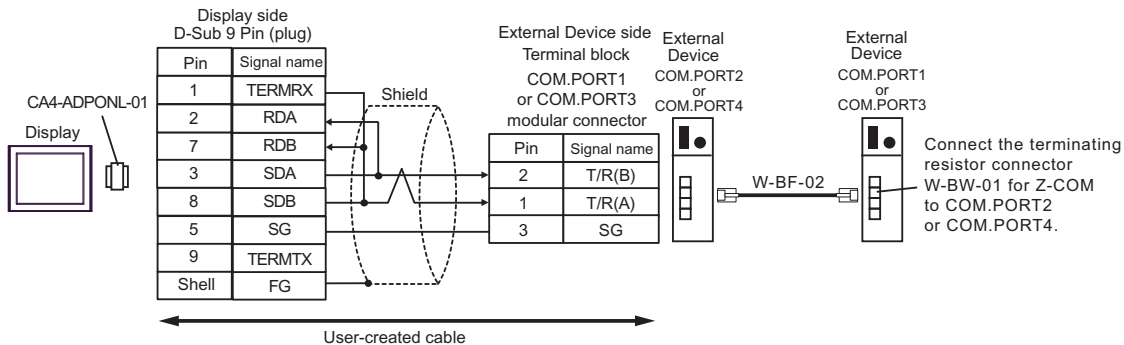

NOTE

- We recommend the TM4P-66P from HIROSE ELECTRIC CO., LTD. as the modular connector.
- To use the External Device's COM.PORT, pair COM.PORT1 with COM.PORT2, and COM.PORT3 with COM.PORT4.

12E)

- 1:1 Connection

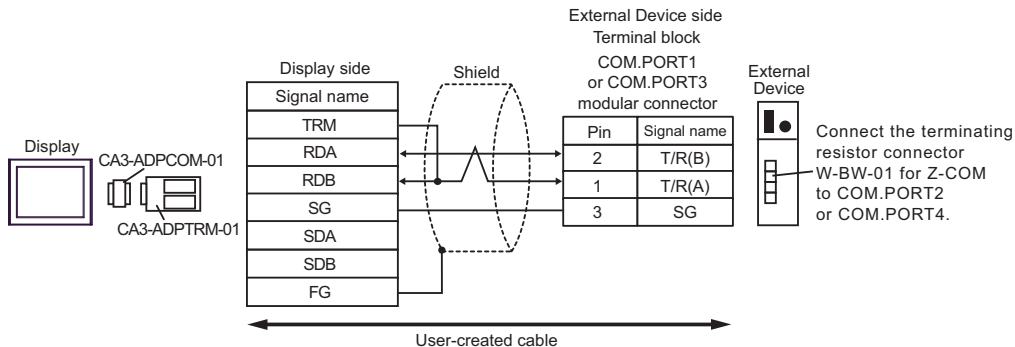

- 1:n Connection

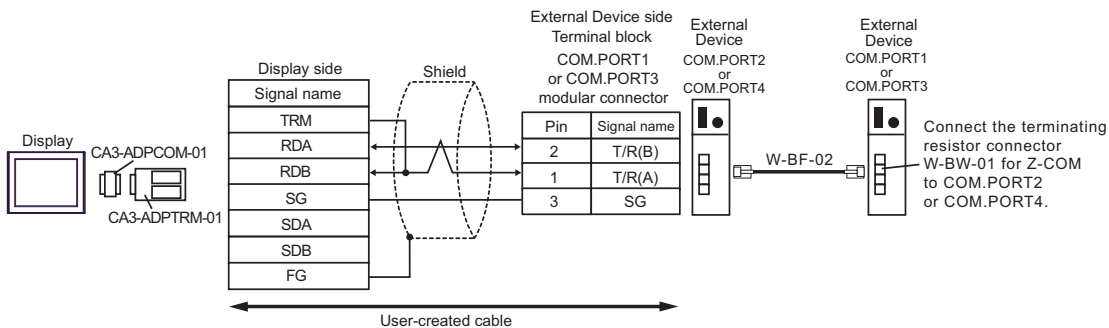

NOTE

- We recommend the TM4P-66P from HIROSE ELECTRIC CO., LTD. as the modular connector.
- To use the External Device's COM.PORT, pair COM.PORT1 with COM.PORT2, and COM.PORT3 with COM.PORT4.

12F)

- 1:1 Connection

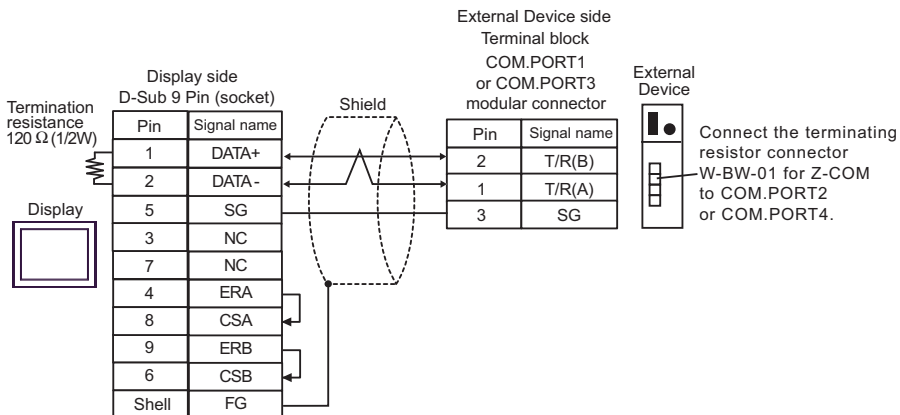

- 1:n Connection

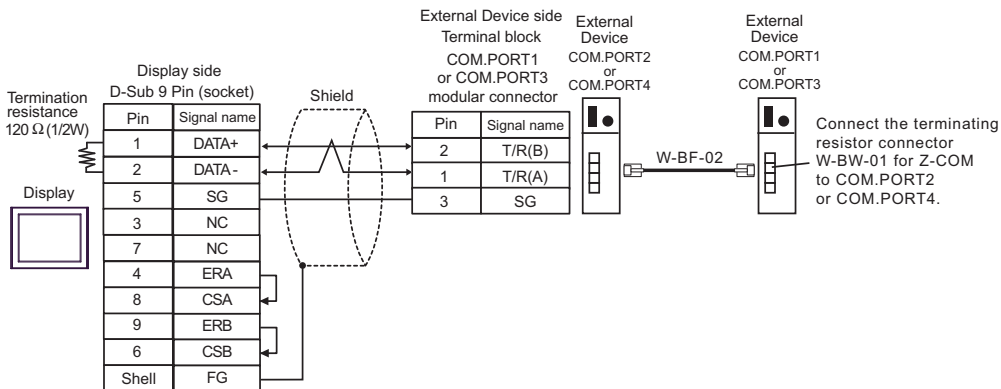

NOTE

- We recommend the TM4P-66P from HIROSE ELECTRIC CO., LTD. as the modular connector.
- To use the External Device's COM.PORT, pair COM.PORT1 with COM.PORT2, and COM.PORT3 with COM.PORT4.

12G)

• 1:1 Connection

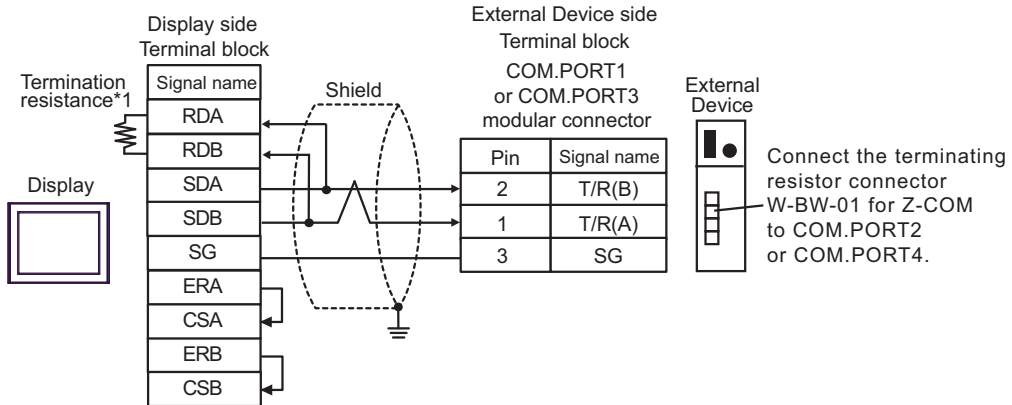

• 1:n Connection

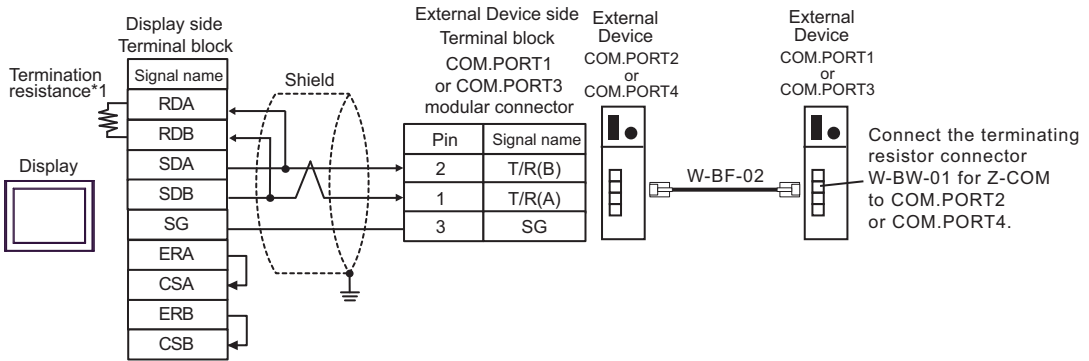

NOTE

- We recommend the TM4P-66P from HIROSE ELECTRIC CO., LTD. as the modular connector.
- To use the External Device's COM.PORT, pair COM.PORT1 with COM.PORT2, and COM.PORT3 with COM.PORT4.

*1 The resistance in the Display is used as the termination resistance. Set the value of the DIP Switch on the rear of the Display as shown in the table below.

DIP Switch No.	Set Value
1	OFF
2	OFF
3	ON
4	ON

12H)

- 1:1 Connection

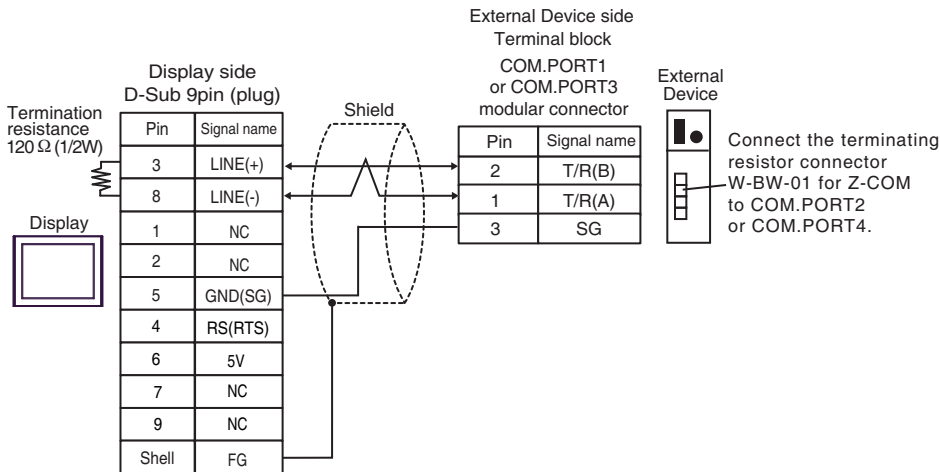

- 1:n Connection

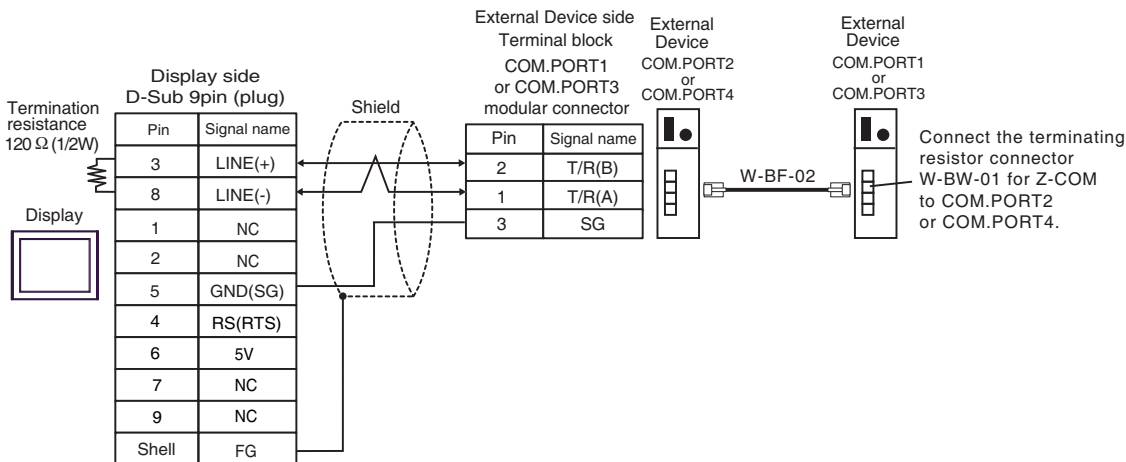

IMPORTANT • The 5V output (Pin #6) on the Display is the power for the Siemens AG's PROFIBUS connector. Do not use it for other devices.

NOTE

- We recommend the TM4P-66P from HIROSE ELECTRIC CO., LTD. as the modular connector.
- To use the External Device's COM.PORT, pair COM.PORT1 with COM.PORT2, and COM.PORT3 with COM.PORT4.
- In COM on the GP-4107, the SG and FG terminals are isolated.

12I)

• 1:1 Connection

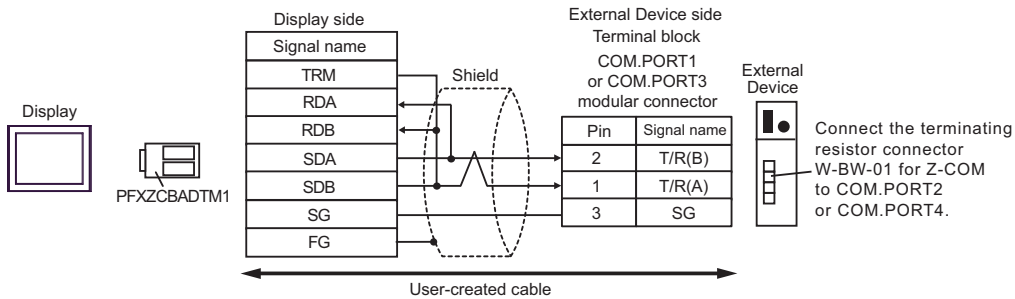

• 1:n Connection

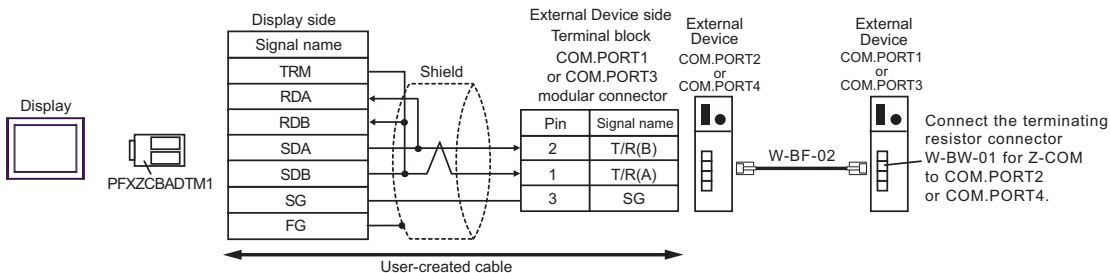

NOTE

- We recommend the TM4P-66P from HIROSE ELECTRIC CO., LTD. as the modular connector.
- To use the External Device's COM.PORT, pair COM.PORT1 with COM.PORT2, and COM.PORT3 with COM.PORT4.

12J)

- 1:1 Connection

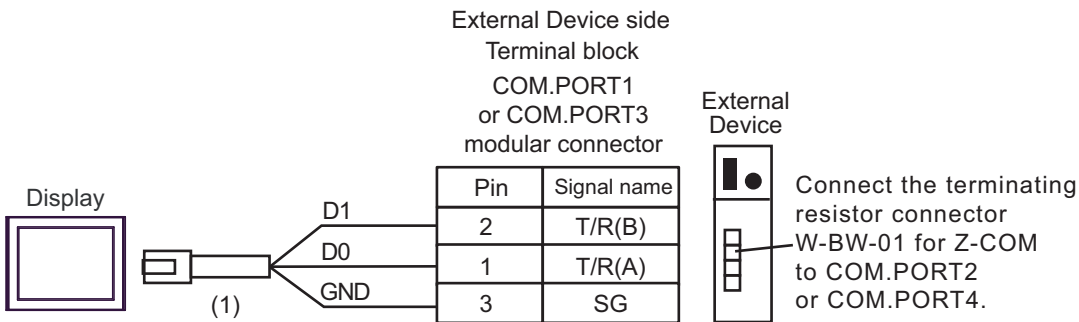

- 1:n Connection

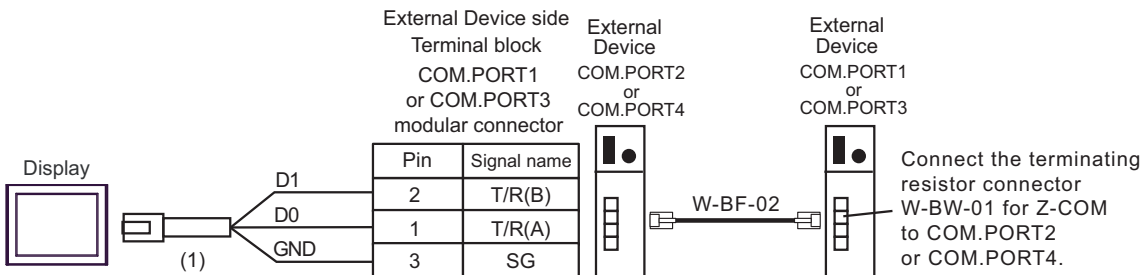

NOTE

- We recommend the TM4P-66P from HIROSE ELECTRIC CO., LTD. as the modular connector.
- To use the External Device's COM.PORT, pair COM.PORT1 with COM.PORT2, and COM.PORT3 with COM.PORT4.

Number	Name	Notes
(1)	RJ45 RS-485 Cable (5m) by Pro-face PFXZLMCBRJ81	

12K)

- 1:1 Connection

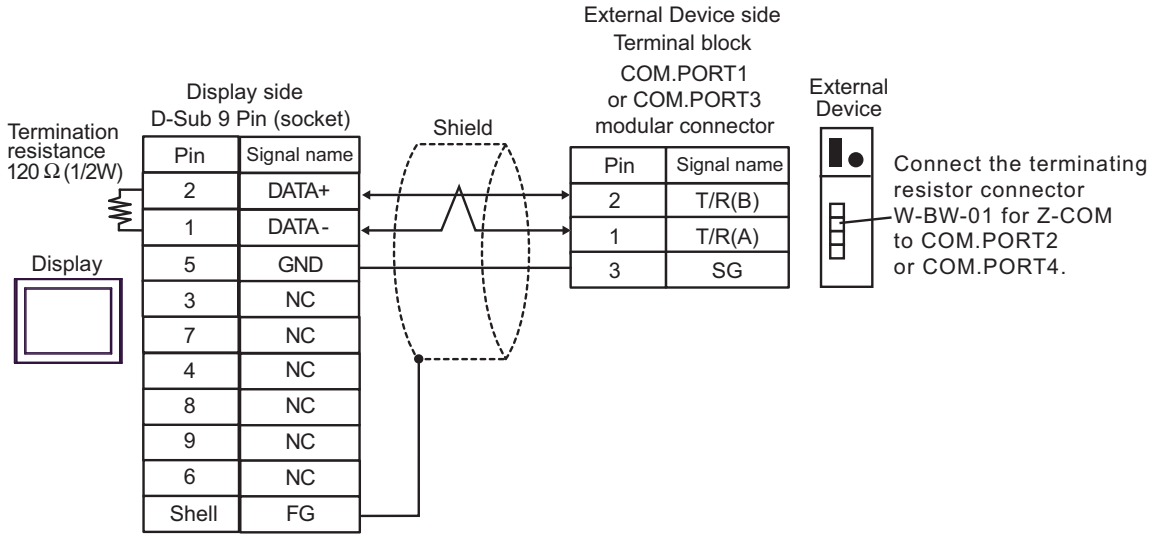

- 1:n Connection

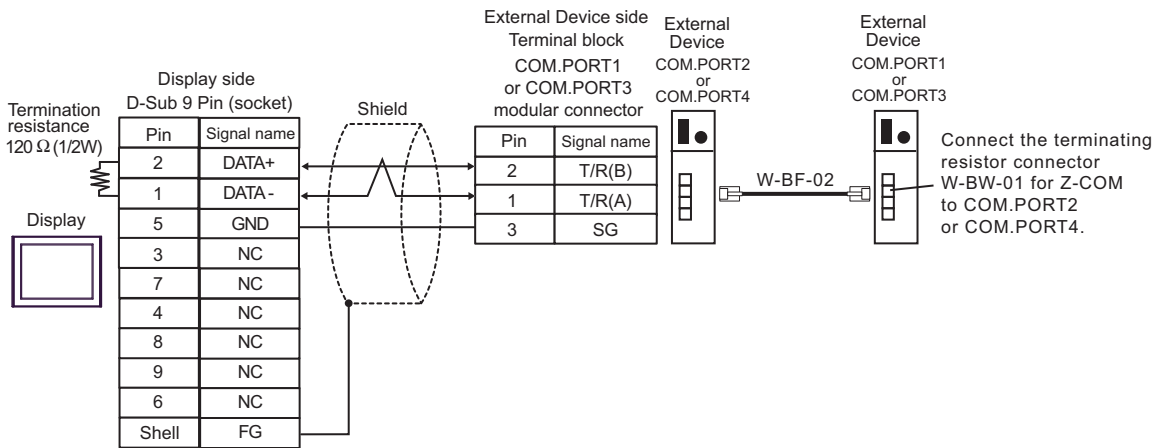

NOTE

- We recommend the TM4P-66P from HIROSE ELECTRIC CO., LTD. as the modular connector.
- To use the External Device's COM.PORT, pair COM.PORT1 with COM.PORT2, and COM.PORT3 with COM.PORT4.

6 Supported Device

Range of supported device address is shown in the table below. Please note that the actually supported range of the devices varies depending on the External Device to be used. Please check the actual range in the manual of your External Device.

Enter the External Device address in the dialog below.

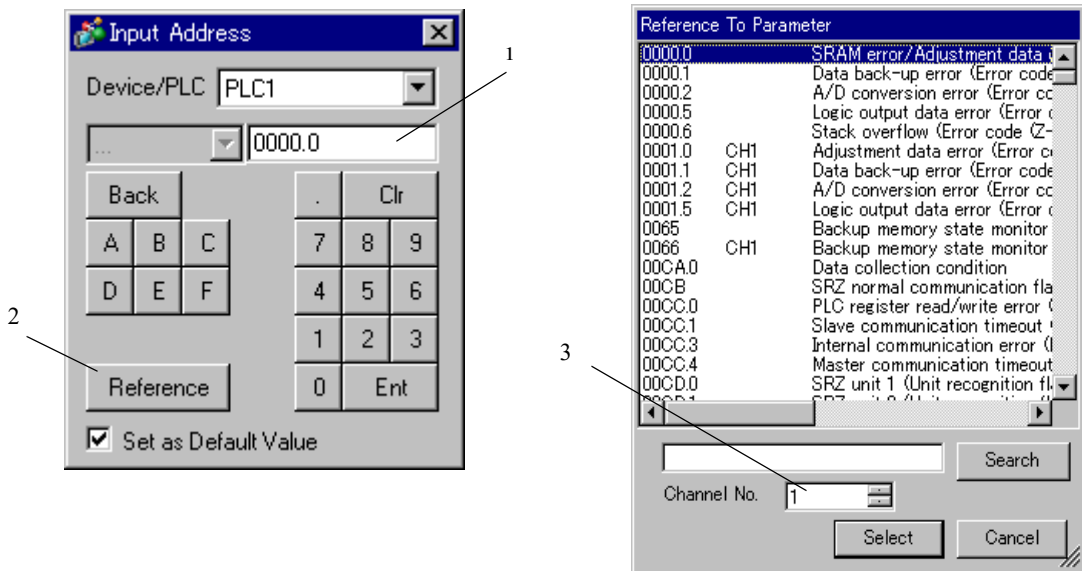



- | | |
|----------------|---|
| 1. Address | Enter the address. |
| 2. Reference | Available parameter list ([Reference To Parameter] dialog box) is displayed.
Click the parameter to use and press “Select”, then the address is entered. |
| 3. Channel No. | Enter the channel No. to be displayed on the list.
[channel No.] is displayed when “SRZ (Z-COM)” of the series of the external device is selected. |

NOTE

- When [Set as Default Value] is selected, the value displays as the default when entering a new address.

6.1 CB Series

 This address can be specified as system data area.

Device	Bit Address	Word Address	32 bits	Remarks
Holding Register	0000.0-001C.F	0000-001C		*1

*1 When you write the bit address, the Display reads the word address corresponding to that of the External Device first. Then, it changes the target bit address among the word data once read and returns the word data to the External Device. Note that the correct data may not be written if you change the word address value in the ladder program while the Display reads the data of the External Device and returns it to the External Device.

IMPORTANT • To set [Enable System Data Area] in the system area setting of GP-Pro EX may cause malfunction. Do not set [Enable System Data Area].

NOTE • You can set only Read Area Size for the system data area available to use in the Temperature Controller. Please refer to the GP-Pro EX Reference Manual for reading area size.

Cf. GP-Pro EX Reference Manual "LS Area (Direct Access Method Area)"

- Please refer to the precautions on manual notation for icons in the table.

 "Manual Symbols and Terminology"

- Even if you use the nonexistent address, read error may not be displayed. In this case, "0" is retained for the read data. Note that the writing error is displayed.
-

6.2 FB400/900Series

 This address can be specified as system data area.

Device	Bit Address	Word Address	32 bits	Remarks
Holding Register	0000.0-150F.F	0000-150F		*1

*1 When you write the bit address, the Display reads the word address corresponding to that of the External Device first. Then, it changes the target bit address among the word data once read and returns the word data to the External Device. Note that the correct data may not be written if you change the word address value in the ladder program while the Display reads the data of the External Device and returns it to the External Device.

IMPORTANT • To set [Enable System Data Area] in the system area setting of GP-Pro EX may cause malfunction. Do not set [Enable System Data Area].

NOTE

- You can set only Read Area Size for the system data area available to use in the Temperature Controller. Please refer to the GP-Pro EX Reference Manual for reading area size.

Cf. GP-Pro EX Reference Manual "LS Area (Direct Access Method Area)"

- Please refer to the precautions on manual notation for icons in the table.

 "Manual Symbols and Terminology"

- Even if you use the nonexistent address, read error may not be displayed. In this case, "0" is retained for the read data. Note that the writing error is displayed.

6.3 HA900/400 Series

 This address can be specified as system data area.

Device	Bit Address	Word Address	32 bits	Remarks
Holding Register	0000.0-0535.F	0000-0535		*1

- *1 When you write the bit address, the Display reads the word address corresponding to that of the External Device first. Then, it changes the target bit address among the word data once read and returns the word data to the External Device. Note that the correct data may not be written if you change the word address value in the ladder program while the Display reads the data of the External Device and returns it to the External Device.

IMPORTANT

- To set [Enable System Data Area] in the system area setting of GP-Pro EX may cause malfunction. Do not set [Enable System Data Area].

NOTE

- You can set only Read Area Size for the system data area available to use in the Temperature Controller. Please refer to the GP-Pro EX Reference Manual for reading area size.

Cf. GP-Pro EX Reference Manual "LS Area (Direct Access Method Area)"

- Please refer to the precautions on manual notation for icons in the table.

 "Manual Symbols and Terminology"

- Even if you use the nonexistent address, read error may not be displayed. In this case, "0" is retained for the read data. Note that the writing error is displayed.

6.4 MA900/901 Series

 This address can be specified as system data area.

Device	Bit Address	Word Address	32 bits	Remarks
Holding Register	0000.0-14A0.F	0000-14A0		*1

*1 When you write the bit address, the Display reads the word address corresponding to that of the External Device first. Then, it changes the target bit address among the word data once read and returns the word data to the External Device. Note that the correct data may not be written if you change the word address value in the ladder program while the Display reads the data of the External Device and returns it to the External Device.

IMPORTANT • To set [Enable System Data Area] in the system area setting of GP-Pro EX may cause malfunction. Do not set [Enable System Data Area].

NOTE • You can set only Read Area Size for the system data area available to use in the Temperature Controller. Please refer to the GP-Pro EX Reference Manual for reading area size.

Cf. GP-Pro EX Reference Manual "LS Area (Direct Access Method Area)"

- Please refer to the precautions on manual notation for icons in the table.

 "Manual Symbols and Terminology"

- Even if you use the nonexistent address, read error may not be displayed. In this case, "0" is retained for the read data. Note that the writing error is displayed.
-

6.5 SRV Series

 This address can be specified as system data area.

Device	Bit Address	Word Address	32 bits	Remarks
Holding Register	0000.0-1880.F	0000-1880		*1

*1 When you write the bit address, the Display reads the word address corresponding to that of the External Device first. Then, it changes the target bit address among the word data once read and returns the word data to the External Device. Note that the correct data may not be written if you change the word address value in the ladder program while the Display reads the data of the External Device and returns it to the External Device.

IMPORTANT • To set [Enable System Data Area] in the system area setting of GP-Pro EX may cause malfunction. Do not set [Enable System Data Area].

- NOTE** • You can set only Read Area Size for the system data area available to use in the Temperature Controller. Please refer to the GP-Pro EX Reference Manual for reading area size.

Cf. GP-Pro EX Reference Manual "LS Area (Direct Access Method Area)"

- Please refer to the precautions on manual notation for icons in the table.
☞ "Manual Symbols and Terminology"
- Even if you use the nonexistent address, read error may not be displayed. In this case, "0" is retained for the read data. Note that the writing error is displayed.

6.6 SRX Series

 This address can be specified as system data area.

Device	Bit Address	Word Address	32 bits	Remarks
Holding Register	0000.0-1883.F	0000-1883		*1

- *1 When you write the bit address, the Display reads the word address corresponding to that of the External Device first. Then, it changes the target bit address among the word data once read and returns the word data to the External Device. Note that the correct data may not be written if you change the word address value in the ladder program while the Display reads the data of the External Device and returns it to the External Device.

- IMPORTANT** • To set [Enable System Data Area] in the system area setting of GP-Pro EX may cause malfunction. Do not set [Enable System Data Area].



- NOTE** • You can set only Read Area Size for the system data area available to use in the Temperature Controller. Please refer to the GP-Pro EX Reference Manual for reading area size.

Cf. GP-Pro EX Reference Manual "LS Area (Direct Access Method Area)"

- Please refer to the precautions on manual notation for icons in the table.
☞ "Manual Symbols and Terminology"
- Even if you use the nonexistent address, read error may not be displayed. In this case, "0" is retained for the read data. Note that the writing error is displayed.

6.7 SA100 Series

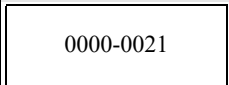
 This address can be specified as system data area.

Device	Bit Address	Word Address	32 bits	Remarks
Holding Register	0000.0-0021.F	 0000-0021		*1

*1 When you write the bit address, the Display reads the word address corresponding to that of the External Device first. Then, it changes the target bit address among the word data once read and returns the word data to the External Device. Note that the correct data may not be written if you change the word address value in the ladder program while the Display reads the data of the External Device and returns it to the External Device.

IMPORTANT • To set [Enable System Data Area] in the system area setting of GP-Pro EX may cause malfunction. Do not set [Enable System Data Area].



NOTE • You can set only Read Area Size for the system data area available to use in the Temperature Controller. Please refer to the GP-Pro EX Reference Manual for reading area size.

Cf. GP-Pro EX Reference Manual "LS Area (Direct Access Method Area)"

- Please refer to the precautions on manual notation for icons in the table.
 "Manual Symbols and Terminology"
- Even if you use the nonexistent address, read error may not be displayed. In this case, "0" is retained for the read data. Note that the writing error is displayed.

6.8 SA200 Series

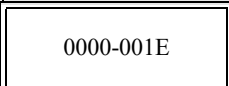
 This address can be specified as system data area.

Device	Bit Address	Word Address	32 bits	Remarks
Holding Register	0000.0-001E.F	 0000-001E		*1

*1 When you write the bit address, the Display reads the word address corresponding to that of the External Device first. Then, it changes the target bit address among the word data once read and returns the word data to the External Device. Note that the correct data may not be written if you change the word address value in the ladder program while the Display reads the data of the External Device and returns it to the External Device.

IMPORTANT • To set [Enable System Data Area] in the system area setting of GP-Pro EX may cause malfunction. Do not set [Enable System Data Area].

- NOTE**
- You can set only Read Area Size for the system data area available to use in the Temperature Controller. Please refer to the GP-Pro EX Reference Manual for reading area size.
 - Cf. GP-Pro EX Reference Manual "LS Area (Direct Access Method Area)"
 - Please refer to the precautions on manual notation for icons in the table.
 - ☞ "Manual Symbols and Terminology"
 - Even if you use the nonexistent address, read error may not be displayed. In this case, "0" is retained for the read data. Note that the writing error is displayed.

6.9 SR Mini HG(H-PCP-A)Series

 This address can be specified as system data area.

Device	Bit Address	Word Address	32 bits	Remarks
Holding Register	0000.0-02EE.F	0000-02EE		*1

- *1 When you write the bit address, the Display reads the word address corresponding to that of the External Device first. Then, it changes the target bit address among the word data once read and returns the word data to the External Device. Note that the correct data may not be written if you change the word address value in the ladder program while the Display reads the data of the External Device and returns it to the External Device.

- IMPORTANT**
- To set [Enable System Data Area] in the system area setting of GP-Pro EX may cause malfunction. Do not set [Enable System Data Area].

- NOTE**
- You can set only Read Area Size for the system data area available to use in the Temperature Controller. Please refer to the GP-Pro EX Reference Manual for reading area size.
 - Cf. GP-Pro EX Reference Manual "LS Area (Direct Access Method Area)"
 - Please refer to the precautions on manual notation for icons in the table.
 - ☞ "Manual Symbols and Terminology"
 - Even if you use the nonexistent address, read error may not be displayed. In this case, "0" is retained for the read data. Note that the writing error is displayed.

6.10 SR Mini HG(H-PCP-J) Series

 This address can be specified as system data area.

Device	Bit Address	Word Address	32 bits	Remarks
Holding Register	0000.0-1DEE.F	0000-1DEE		*1

*1 When you write the bit address, the Display reads the word address corresponding to that of the External Device first. Then, it changes the target bit address among the word data once read and returns the word data to the External Device. Note that the correct data may not be written if you change the word address value in the ladder program while the Display reads the data of the External Device and returns it to the External Device.

IMPORTANT

- To set [Enable System Data Area] in the system area setting of GP-Pro EX may cause malfunction. Do not set [Enable System Data Area].

NOTE

- You can set only Read Area Size for the system data area available to use in the Temperature Controller. Please refer to the GP-Pro EX Reference Manual for reading area size.
 - Cf. GP-Pro EX Reference Manual "LS Area (Direct Access Method Area)"
- Please refer to the precautions on manual notation for icons in the table.
 -  "Manual Symbols and Terminology"
- Even if you use the nonexistent address, read error may not be displayed. In this case, "0" is retained for the read data. Note that the writing error is displayed.

6.11 SRZ (Z-TIO) / SRZ (Z-DIO) Series

 This address can be specified as system data area.

Device	Bit Address	Word Address	32 bits	Remarks
Holding Register	0000.0-150F.F	0000-150F		*1

*1 When you write the bit address, the Display reads the word address corresponding to that of the External Device first. Then, it changes the target bit address among the word data once read and returns the word data to the External Device. Note that the correct data may not be written if you change the word address value in the ladder program while the Display reads the data of the External Device and returns it to the External Device.

IMPORTANT



- To set [Enable System Data Area] in the system area setting of GP-Pro EX may cause malfunction. Do not set [Enable System Data Area].

NOTE

- You can set only Read Area Size for the system data area available to use in the Temperature Controller. Please refer to the GP-Pro EX Reference Manual for reading area size.
 - Cf. GP-Pro EX Reference Manual "LS Area (Direct Access Method Area)"
- Please refer to the precautions on manual notation for icons in the table.
 -  "Manual Symbols and Terminology"
- Even if you use the nonexistent address, read error may not be displayed. In this case, "0" is retained for the read data. Note that the writing error is displayed.

6.12 SRZ (Z-CT) Series

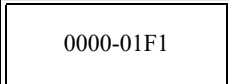
 This address can be specified as system data area.

Device	Bit Address	Word Address	32 bits	Remarks
Holding Register	0000.0-01F1.F	 0000-01F1		*1

*1 When you write the bit address, the Display reads the word address corresponding to that of the External Device first. Then, it changes the target bit address among the word data once read and returns the word data to the External Device. Note that the correct data may not be written if you change the word address value in the ladder program while the Display reads the data of the External Device and returns it to the External Device.

IMPORTANT



- To set [Enable System Data Area] in the system area setting of GP-Pro EX may cause malfunction. Do not set [Enable System Data Area].

NOTE

- You can set only Read Area Size for the system data area available to use in the Temperature Controller. Please refer to the GP-Pro EX Reference Manual for reading area size.
 - Cf. GP-Pro EX Reference Manual "LS Area (Direct Access Method Area)"
- Please refer to the precautions on manual notation for icons in the table.
 -  "Manual Symbols and Terminology"
- Even if you use the nonexistent address, read error may not be displayed. In this case, "0" is retained for the read data. Note that the writing error is displayed.

6.13 SRZ (Z-COM) Series

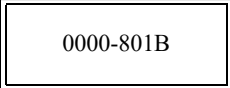
 This address can be specified as system data area.

Device	Bit Address	Word Address	32 bits	Remarks
Holding Register	0000.0-801B.F	 0000-801B		*1

*1 When you write the bit address, the Display reads the word address corresponding to that of the External Device first. Then, it changes the target bit address among the word data once read and returns the word data to the External Device. Note that the correct data may not be written if you change the word address value in the ladder program while the Display reads the data of the External Device and returns it to the External Device.

IMPORTANT

- To set [Enable System Data Area] in the system area setting of GP-Pro EX may cause malfunction. Do not set [Enable System Data Area].

NOTE

- You can set only Read Area Size for the system data area available to use in the Temperature Controller. Please refer to the GP-Pro EX Reference Manual for reading area size.
 - Cf. GP-Pro EX Reference Manual "LS Area (Direct Access Method Area)"
- Please refer to the precautions on manual notation for icons in the table.
 -  "Manual Symbols and Terminology"
- Even if you use the nonexistent address, read error may not be displayed. In this case, "0" is retained for the read data. Note that the writing error is displayed.

7 Device Code and Address Code

Use device code and address code when you select "Device Type & Address" for the address type in data displays.

7.1 CB Series

Device	Device Name	Device Code (HEX)	Address Code
Holding Register	-	0080	Same as Word Address

7.2 FB900/400 Series

Device	Device Name	Device Code (HEX)	Address Code
Holding Register	-	0080	Same as Word Address

7.3 HA900/400 Series

Device	Device Name	Device Code (HEX)	Address Code
Holding Register	-	0080	Same as Word Address

7.4 MA900/901 Series

Device	Device Name	Device Code (HEX)	Address Code
Holding Register	-	0080	Same as Word Address

7.5 SRV Series

Device	Device Name	Device Code (HEX)	Address Code
Holding Register	-	0080	Same as Word Address

7.6 SRX Series

Device	Device Name	Device Code (HEX)	Address Code
Holding Register	-	0080	Same as Word Address

7.7 SA100 Series

Device	Device Name	Device Code (HEX)	Address Code
Holding Register	-	0080	Same as Word Address

7.8 SA200 Series

Device	Device Name	Device Code (HEX)	Address Code
Holding Register	-	0080	Same as Word Address

7.9 SR Mini Series

Device	Device Name	Device Code (HEX)	Address Code
Holding Register	-	0080	Same as Word Address

7.10 SR Mini HG Series

Device	Device Name	Device Code (HEX)	Address Code
Holding Register	-	0080	Same as Word Address

7.11 SRZ (Z-TIO) / SRZ (Z-DIO) Series

Device	Device Name	Device Code (HEX)	Address Code
Holding Register	-	0080	Same as Word Address

7.12 SRZ (Z-CT) Series

Device	Device Name	Device Code (HEX)	Address Code
Holding Register	-	0080	Same as Word Address

7.13 SRZ (Z-COM) Series

Device	Device Name	Device Code (HEX)	Address Code
Holding Register	-	0080	Same as Word Address

8 Error Messages

Error messages are displayed on the screen of the Display as follows: "No.:Device Name:Error Message(Error Occurrence Area)". Each description is shown below.

Item	Description
No.	Error No.
Device Name	Name of the External Device where error occurs. Device name is a title of the External Device set with GP-Pro EX.(Initial value[PLC1])
Error Message	Displays messages related to the error which occurs.
Error Occurrence Area	<p>Displays IP address or device address of the External Device where error occurs, or error codes received from the External Device.</p> <p>NOTE</p> <ul style="list-style-type: none"> • IP address is displayed such as "IP address(Decimal): MAC address(Hex)". • Device address is displayed such as "Address: Device address". • Received error codes are displayed such as "Decimal[Hex]".

Display Examples of Error Messages

"RHAA035: PLC1: Error has been responded for device write command (Error Code: 2[02H])"

NOTE

- Refer to your External Device manual for details on received error codes.
- Refer to "Display-related errors" in "Maintenance/Troubleshooting Guide" for details on the error messages common to the driver.