



A Series Computer Link Driver

1	System Configuration.....	3
2	Selection of External Device	10
3	Example of Communication Setting.....	11
4	Setup Items	27
5	Cable Diagram	32
6	Supported Device.....	57
7	Device Code and Address Code.....	61
8	Error Messages	62

Introduction

This manual describes how to connect the Display and the External Device (target PLC).

In this manual, the connection procedure will be described by following the below sections:

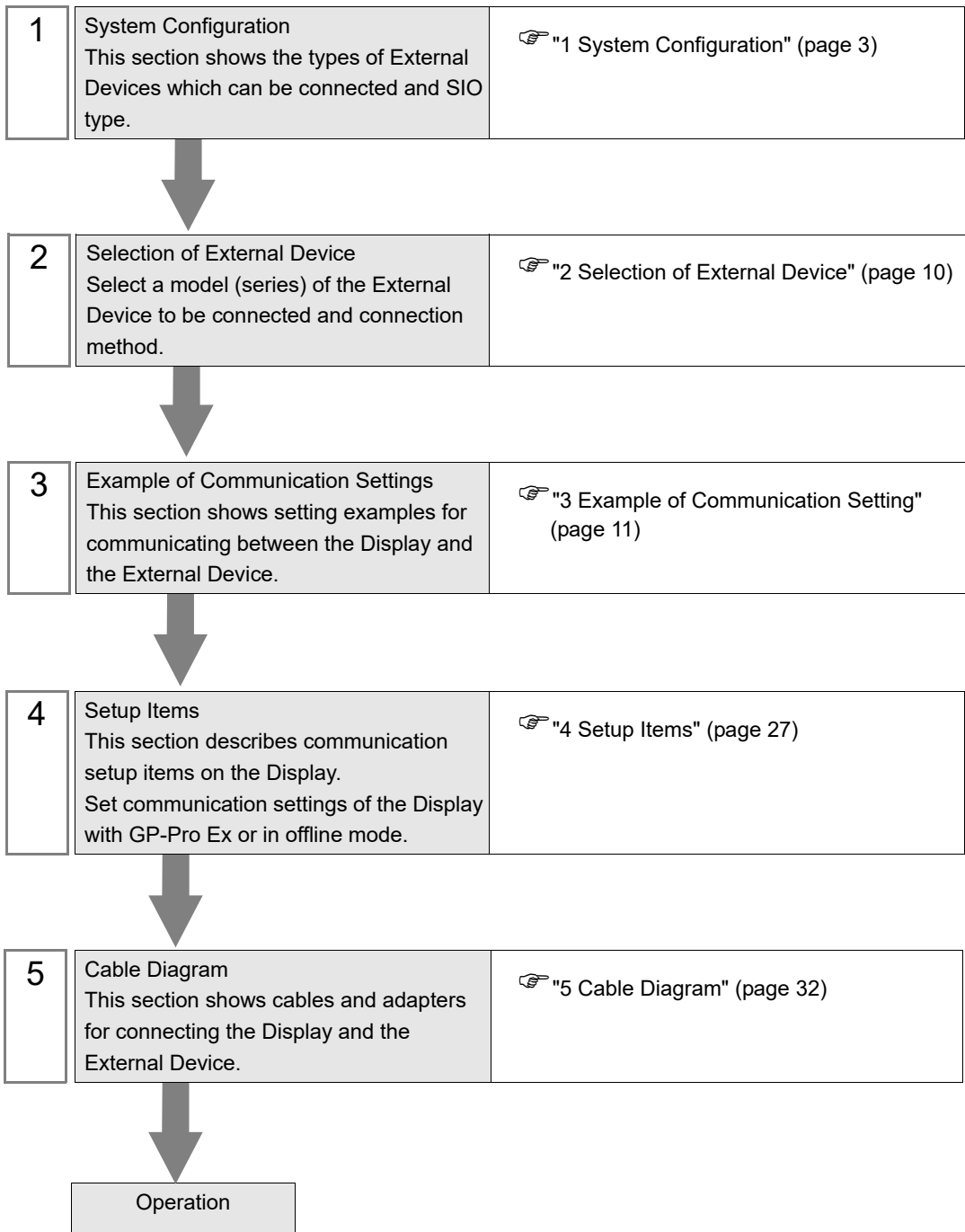

1 System Configuration

The system configuration in the case when the External Device of Mitsubishi Electric Corporation and the Display are connected is shown.

Series	CPU	Link I/F	SIO Type	Setting Example	Cable Diagram
MELSEC AnA Series	A2ACPU A2ACPU-S1 A3ACPU A2UCPU A2UCPU-S1 A3UCPU A4UCPU	AJ71C24-S6 AJ71C24-S8	RS232C	Setting Example 1 (page 11)	Cable Diagram 1 (page 32)
			RS422/485 (4wire)	Setting Example 5 (page 19)	Cable Diagram 2 (page 34)
			RS422/ 485(4Wire) Multilink	Setting Example 5 (page 19)	Cable Diagram 4 (page 45)
		AJ71UC24	RS232C	Setting Example 2 (page 13)	Cable Diagram 1 (page 32)
			RS422/485 (4wire)	Setting Example 6 (page 21)	Cable Diagram 2 (page 34)
			RS422/ 485(4Wire) Multilink	Setting Example 6 (page 21)	Cable Diagram 4 (page 45)
	A2USCPU A2USHCPU-S1	A1SJ71C24-R2 A1SJ71UC24-R2	RS232C	Setting Example 3 (page 15)	Cable Diagram 3 (page 43)
		A1SJ71C24-R4 A1SJ71UC24-R4	RS422/485 (4wire)	Setting Example 7 (page 23)	Cable Diagram 2 (page 34)
			RS422/ 485(4Wire) Multilink	Setting Example 7 (page 23)	Cable Diagram 4 (page 45)

Series	CPU	Link I/F	SIO Type	Setting Example	Cable Diagram
MELSEC AnN Series	A1NCPU A2NCPU A2NCPU-S1 A3NCPU	AJ71C24 AJ71C24-S3 AJ71C24-S6 AJ71C24-S8	RS232C	Setting Example 1 (page 11)	Cable Diagram 1 (page 32)
			RS422/485 (4wire)	Setting Example 5 (page 19)	Cable Diagram 2 (page 34)
			RS422/ 485(4Wire) Multilink	Setting Example 5 (page 19)	Cable Diagram 4 (page 45)
		AJ71UC24	RS232C	Setting Example 2 (page 13)	Cable Diagram 1 (page 32)
			RS422/485 (4wire)	Setting Example 6 (page 21)	Cable Diagram 2 (page 34)
			RS422/ 485(4Wire) Multilink	Setting Example 6 (page 21)	Cable Diagram 4 (page 45)
	A1SCPU A1SJCPU A1SJHCPU A1SHCPU A2SHCPU	A1SJ71C24-R2 A1SJ71UC24-R2	RS232C	Setting Example 3 (page 15)	Cable Diagram 3 (page 43)
		A1SJ71C24-R4 A1SJ71UC24-R4	RS422/485 (4wire)	Setting Example 7 (page 23)	Cable Diagram 2 (page 34)
			RS422/ 485(4Wire) Multilink	Setting Example 7 (page 23)	Cable Diagram 4 (page 45)
		A0J2CPU A0J2HCPU	A0J2-C214-S1	RS422/485 (4wire)	Setting Example 8 (page 25)
	RS422/ 485(4Wire) Multilink			Setting Example 8 (page 25)	Cable Diagram 4 (page 45)
	A2CCPUC24	Link port on CPU	RS232C	Setting Example 4 (page 17)	Cable Diagram 3 (page 43)
MELSEC QnA Series	Q2ACPU Q2ACPU-S1 Q3ACPU Q4ACPU Q4ARCPU	AJ71UC24	RS232C	Setting Example 2 (page 13)	Cable Diagram 1 (page 32)
			RS422/485 (4wire)	Setting Example 6 (page 21)	Cable Diagram 2 (page 34)
			RS422/ 485(4Wire) Multilink	Setting Example 6 (page 21)	Cable Diagram 4 (page 45)
	Q2ASCPU Q2ASCPU-S1 Q2ASHCPU Q2ASHCPU-S1	A1SJ71UC24-R2 A1SJ71UC24-PRF	RS232C	Setting Example 3 (page 15)	Cable Diagram 3 (page 43)
		A1SJ71UC24-R4	RS422/485 (4wire)	Setting Example 7 (page 23)	Cable Diagram 2 (page 34)
			RS422/ 485(4Wire) Multilink	Setting Example 7 (page 23)	Cable Diagram 4 (page 45)

Series	CPU	Link I/F	SIO Type	Setting Example	Cable Diagram
MELSEC Q Series	Q02CPU-A Q02HCPU-A Q06HCPU-A	A1SJ71UC24-R2 A1SJ71UC24-PRF	RS232C	Setting Example 3 (page 15)	Cable Diagram 3 (page 43)
		A1SJ71UC24-R4	RS422/485 (4wire)	Setting Example 7 (page 23)	Cable Diagram 2 (page 34)
			RS422/485(4Wire) Multilink	Setting Example 7 (page 23)	Cable Diagram 4 (page 45)

■ Connection Configuration

- 1:1 Connection



- 1:n Connection

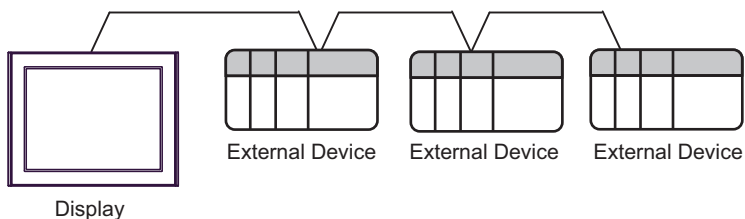

- 1:n Connection (when communicating via network)

You can access other stations via MELSECNET/10, MELSECNET(II), MELSECNET/B.

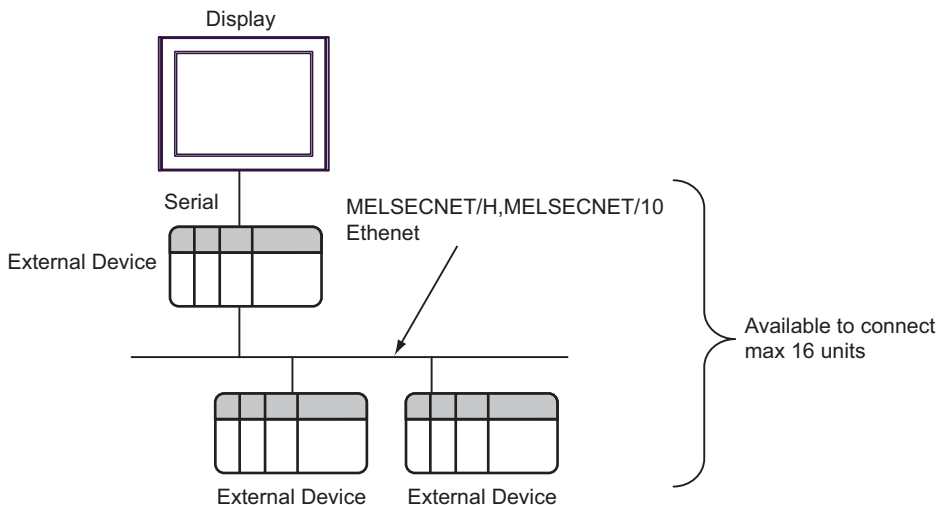

- n:1 Connection (Multilink connection)

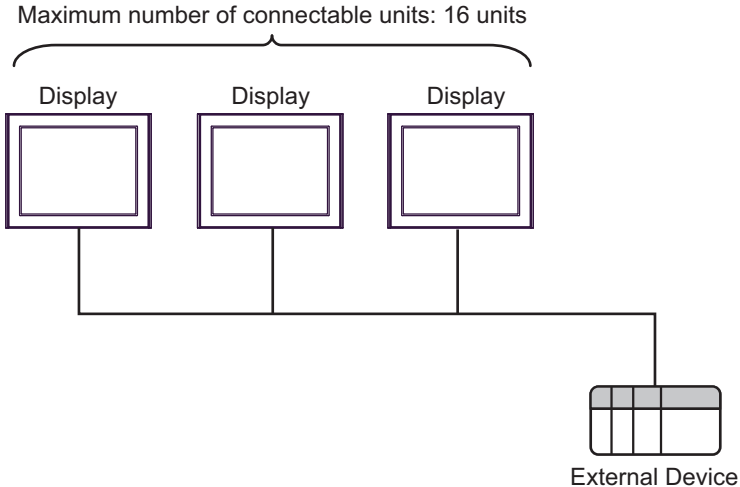

NOTE • The maximum number of connectable Displays is 16 units. However, keeping performance in consideration, the number of Displays that can be substantially used is up to 4.

- n:m Connection (Multilink connection)

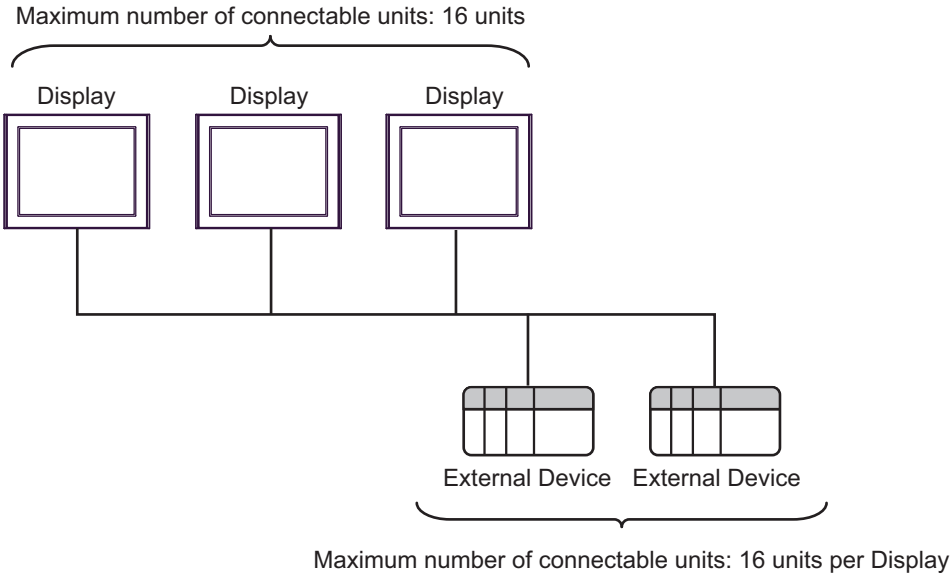

NOTE • The maximum number of connectable Displays is 16 units. However, keeping performance in consideration, the number of Displays that can be substantially used is up to 4.

■ IPC COM Port

When connecting IPC with an External Device, the COM port used depends on the series and SIO type. Please refer to the IPC manual for details.

Usable port

Series	Usable Port		
	RS-232C	RS-422/485(4 wire)	RS-422/485(2 wire)
PS-2000B	COM1 ^{*1} , COM2, COM3 ^{*1} , COM4	-	-
PS-3450A, PS-3451A, PS3000-BA, PS3001-BD	COM1, COM2 ^{*1*2}	COM2 ^{*1*2}	COM2 ^{*1*2}
PS-3650A (T41 model), PS-3651A (T41 model)	COM1 ^{*1}	-	-
PS-3650A (T42 model), PS-3651A (T42 model)	COM1 ^{*1*2} , COM2	COM1 ^{*1*2}	COM1 ^{*1*2}
PS-3700A (Pentium®4-M) PS-3710A	COM1 ^{*1} , COM2 ^{*1} , COM3 ^{*2} , COM4	COM3 ^{*2}	COM3 ^{*2}
PS-3711A	COM1 ^{*1} , COM2 ^{*2}	COM2 ^{*2}	COM2 ^{*2}
PS4000 ^{*3}	COM1, COM2	-	-
PL3000	COM1 ^{*1*2} , COM2 ^{*1} , COM3, COM4	COM1 ^{*1*2}	COM1 ^{*1*2}
PE-4000B Atom N270	COM1, COM2	-	-
PE-4000B Atom N2600	COM1, COM2	COM3 ^{*4} , COM4 ^{*4} , COM5 ^{*4} , COM6 ^{*4}	COM3 ^{*4} , COM4 ^{*4} , COM5 ^{*4} , COM6 ^{*4}
PS5000 (Slim Panel Type Core i3 Model) ^{*5*6}	COM1, COM2 ^{*4}	COM2 ^{*4}	COM2 ^{*4}
PS5000 (Slim Panel Type Atom Model) ^{*5*6}	COM1, COM2 ^{*7}	COM2 ^{*7}	COM2 ^{*7}
PS5000 (Enclosed Panel Type) ^{*8}	COM1	-	-
PS5000 (Modular Type PFXPU/PFXPP) ^{*5*6} PS5000 (Modular Type PFXPL2B5-6)	COM1 ^{*7}	COM1 ^{*7}	COM1 ^{*7}
PS5000 (Modular Type PFXPL2B1-4)	COM1, COM2 ^{*7}	COM2 ^{*7}	COM2 ^{*7}
PS6000 (Advanced Box) PS6000 (Standard Box)	COM1 ^{*9}	*10	*10
PS6000 (Basic Box)	COM1 ^{*9}	COM1 ^{*9}	COM1 ^{*9}

*1 The RI/5V can be switched. Use the IPC's switch to change if necessary.

*2 Set up the SIO type with the DIP Switch. Please set up as follows according to SIO type to be used.

- *3 When making communication between an External Device and COM port on the Expansion slot, only RS-232C is supported. However, ER (DTR/CTS) control cannot be executed because of the specification of COM port.
For connection with External Device, use user-created cables and disable Pin Nos. 1, 4, 6 and 9. Please refer to the IPC manual for details of pin layout.
- *4 Set up the SIO type with the BIOS. Please refer to the IPC manual for details of BIOS.
- *5 When setting up communication between an External Device and the RS-232C/422/485 interface module, use the IPC (RS-232C) or PS5000 (RS-422/485) cable diagrams. However, when using PFXZPBMPR42P2 in a RS-422/485 (4-wire) configuration with no flow control, connect 7.RTS+ and 8.CTS+, and connect 6.RTS- and 9.CTS-.
When using RS-422/485 communication with External Devices, you may need to reduce the transmission speed and increase the TX Wait time.
- *6 To use RS-422/485 communication on the RS-232C/422/485 interface module, the DIP Switch setting is required. Please refer to "Knowledge Base" (FAQs) on the support site. (<http://www.pro-face.com/trans/en/manual/1001.html>)

Settings	FAQ ID
PFXZPBMPR42P2, RS422/485 change method	FA263858
PFXZPBMPR42P2 termination resistor setting	FA263974
PFXZPBMPR44P2, RS422/485 change method	FA264087
PFXZPBMPR44P2 termination resistor setting	FA264088

- *7 Set up the SIO type with the DIP Switch. Please refer to the IPC manual for details of DIP Switch. The BOX Atom has not a switch to set the RS-232C, RS-422/485 mode. Use the BIOS for the setting.
- *8 For the connection with the External Device, on the user-created cable read as if the connector on the Display-side is a M12 A-coding 8 pin socket. The pin assignment is the same as described in the cable diagram. For the M12 A-coding connector, use PFXZPSCNM122.
- *9 In addition to COM1, you can also use the COM port on the optional interface.
- *10 Install the optional interface in the expansion slot.

DIP Switch settings (PL3000 / PS3000 Series)

RS-232C

DIP Switch	Setting	Description
1	OFF*1	Reserved (always OFF)
2	OFF	SIO type: RS-232C
3	OFF	
4	OFF	Output mode of SD (TXD) data: Always output
5	OFF	Terminal resistance (220Ω) insertion to SD (TXD): None
6	OFF	Terminal resistance (220Ω) insertion to RD (RXD): None
7	OFF	Short-circuit of SDA (TXA) and RDA (RXA): Not available
8	OFF	Short-circuit of SDB (TXB) and RDB (RXB): Not available
9	OFF	RS (RTS) Auto control mode: Disabled
10	OFF	

*1 When using PS-3450A, PS-3451A, PS3000-BA and PS3001-BD, turn ON the set value.

RS-422/485 (4 wire)

DIP Switch	Setting	Description
1	OFF	Reserved (always OFF)
2	ON	SIO type: RS-422/485
3	ON	
4	OFF	Output mode of SD (TXD) data: Always output
5	OFF	Terminal resistance (220Ω) insertion to SD (TXD): None
6	OFF	Terminal resistance (220Ω) insertion to RD (RXD): None
7	OFF	Short-circuit of SDA (TXA) and RDA (RXA): Not available
8	OFF	Short-circuit of SDB (TXB) and RDB (RXB): Not available
9	OFF* ¹	RS (RTS) Auto control mode: Disabled
10	OFF* ¹	

*1 When the connection configuration are the n:1 and n:m connections (both Multilink connections), turn ON the set value.

RS-422/485 (2 wire)

DIP Switch	Setting	Description
1	OFF	Reserved (always OFF)
2	ON	SIO type: RS-422/485
3	ON	
4	OFF	Output mode of SD (TXD) data: Always output
5	OFF	Terminal resistance (220Ω) insertion to SD (TXD): None
6	OFF	Terminal resistance (220Ω) insertion to RD (RXD): None
7	ON	Short-circuit of SDA (TXA) and RDA (RXA): Available
8	ON	Short-circuit of SDB (TXB) and RDB (RXB): Available
9	ON	RS (RTS) Auto control mode: Enabled
10	ON	

2 Selection of External Device

Select the External Device to be connected to the Display.

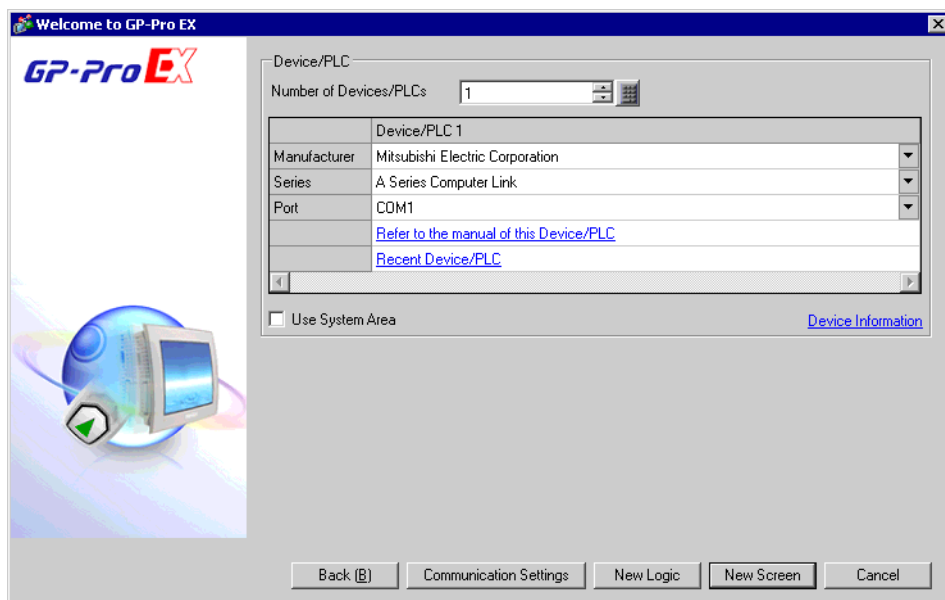

Setup Items	Setup Description
Number of Devices/PLCs	Enter an integer from 1 to 4 to define the number of Devices/PLCs to connect to the display.
Manufacturer	Select the manufacturer of the External Device to connect. Select "Mitsubishi Electric Corporation".
Series	Select the External Device model (series) and the connection method. Select "A Series Computer Link". In System configuration, make sure the External Device you are connecting is supported by "A Series Computer Link". ☞ "1 System Configuration" (page 3)
Port	Select the Display port to connect to the External Device.
Use System Area	Check this option to synchronize the system data area of the Display and the device (memory) of the External Device. When synchronized, you can use the External Device's ladder program to switch the display or display the window on the Display. Cf. GP-Pro EX Reference Manual "LS Area (Direct Access Method Area)" This feature can also be set in GP-Pro EX or in the Display's offline mode. Cf. GP-Pro EX Reference Manual "System Settings [Display Unit] - [System Area] Settings Guide" Cf. Maintenance/Troubleshooting Guide "Main Unit - System Area Settings"

3 Example of Communication Setting

Examples of communication settings of the Display and the External Device, recommended by Pro-face, are shown.

When you use the A Series, use GP-Pro EX and the ladder software to set as below.

3.1 Setting Example 1

■ Settings of GP-Pro EX

◆ Communication Settings

To display the setup screen, from the [Project] menu, point to [System Settings] and select [Device/PLC].

The screenshot shows the 'Device/PLC 1' configuration window. It is divided into several sections:

- Summary:** Manufacturer: Mitsubishi Electric Corporation, Series: A Series Computer Link, Port: COM1. Text Data Mode: 2.
- Communication Settings:**
 - SIQ Type: RS232C, RS422/485(2wire), RS422/485(4wire)
 - Speed: 19200
 - Data Length: 7, 8
 - Parity: NONE, EVEN, ODD
 - Stop Bit: 1, 2
 - Flow Control: NONE, ER(DTR/CTS), XON/XOFF
 - Timeout: 3 (sec)
 - Retry: 2
 - Wait To Send: 0 (ms)
 - Format: Format 4
- RI / VCC:** RI, VCC. A note states: "In the case of RS232C, you can select the 9th pin to RI (Input) or VCC (5V Power Supply). If you use the Digital's RS232C Isolation Unit, please select it to VCC." A 'Default' button is present.
- Device-Specific Settings:** Allowable Number of Devices/PLCs: 16. A table lists: No. 1, Device Name: PLC1, Settings: Station No.=0, PC No.=255. An 'Add Device' button is also visible.

◆ Device Setting

To display the [Individual Device Settings] dialog box, from [Device-Specific Settings] in the [Device/PLC] window, select the external device and click [Settings] .

To connect multiple External Devices, from [Device-Specific Settings] in the [Device/PLC] window, click [Add Device] to add another External Device.

The 'Individual Device Settings' dialog box for PLC1 shows the following fields:

- Station No.: 0
- PC No.: 255

Buttons include 'Default', 'OK (O)', and 'Cancel'.

■ Setting of External Device

Use the DIP switch of the Computer Link Unit for setting. Please refer to the manual of the External Device for more details.

◆ Mode Setting Rotary Switch

Settings	Setup Description
4	Protocol mode in Form 4

◆ Communication Setting DIP Switch

DIP Switch	Settings	Setup Description
SW11	OFF	Main channel setting
SW12	OFF	Data bit setting
SW13	OFF	Transmission speed setting
SW14	ON	
SW15	ON	
SW16	ON	Parity bit setting whether enable or disable
SW17	ON	Parity setting whether Even or Odd
SW18	ON	Stop bit setting
SW21	ON	Sum check setting whether enable or disable
SW22	ON	Write setting during RUN whether enable or disable
SW23	OFF	Termination resistance on the sending side whether exist or not exist
SW24	OFF	Termination resistance on the receiving side whether exist or not exist

◆ Station Setting Rotary Switch

Rotary Switch	Settings	Setup Description
X10	0	Station No. setting
X1	0	

3.2 Setting Example 2

■ Settings of GP-Pro EX

◆ Communication Settings

To display the setup screen, from the [Project] menu, point to [System Settings] and select [Device/PLC].

◆ Device Setting

To display the [Individual Device Settings] dialog box, from [Device-Specific Settings] in the [Device/PLC] window, select the external device and click [Settings] .

To connect multiple External Devices, from [Device-Specific Settings] in the [Device/PLC] window, click [Add Device] to add another External Device.

■ Setting of External Device

Use the DIP switch of the Computer Link Unit for setting. Please refer to the manual of the External Device for more details.

◆ Mode Setting Rotary Switch

Settings	Setup Description
4	Protocol mode in Form 4

◆ Communication Setting DIP Switch

DIP Switch	Settings	Setup Description
SW11	OFF	Main channel setting
SW12	OFF	Data bit setting
SW13	OFF	Transmission speed setting
SW14	ON	
SW15	ON	
SW16	ON	Parity bit setting whether enable or disable
SW17	ON	Parity setting whether Even or Odd
SW18	ON	Stop bit setting
SW21	ON	Sum check setting whether enable or disable
SW22	ON	Write setting during RUN whether enable or disable
SW23	ON	Computer link/Multiple drop link selection
SW24	Unused	Unused

◆ Station Setting Rotary Switch

Rotary Switch	Settings	Setup Description
X10	0	Station No. setting
X1	0	

3.3 Setting Example 3

■ Settings of GP-Pro EX

◆ Communication Settings

To display the setup screen, from the [Project] menu, point to [System Settings] and select [Device/PLC].

The screenshot shows the 'Device/PLC 1' configuration window. It includes a 'Summary' section with fields for Manufacturer (Mitsubishi Electric Corporation), Series (A Series Computer Link), and Port (COM1). Below this is the 'Communication Settings' section, which includes radio buttons for SID Type (RS232C, RS422/485(2wire), RS422/485(4wire)), a Speed dropdown (19200), Data Length (7, 8), Parity (NONE, EVEN, ODD), Stop Bit (1, 2), Flow Control (NONE, ER(DTR/CTS), XON/XOFF), and numeric input fields for Timeout (3), Retry (2), and Wait To Send (0). A 'Format' dropdown is set to 'Format 4'. There is also a section for 'RI / VCC' with radio buttons and explanatory text. At the bottom, the 'Device-Specific Settings' section shows 'Allowable Number of Devices/PLCs' as 16 and a table with one device: 'PLC1' with 'Station No.=0' and 'PC No.=255'.

◆ Device Setting

To display the [Individual Device Settings] dialog box, from [Device-Specific Settings] in the [Device/PLC] window, select the external device and click [Settings] .

To connect multiple External Devices, from [Device-Specific Settings] in the [Device/PLC] window, click [Add Device] to add another External Device.

The screenshot shows the 'Individual Device Settings' dialog box for 'PLC1'. It contains two numeric input fields: 'Station No.' with the value 0 and 'PC No.' with the value 255. Below these fields are 'Default', 'OK (O)', and 'Cancel' buttons.

■ Setting of External Device

Use the DIP switch of the Computer Link Unit for setting. Please refer to the manual of the External Device for more details.

◆ Mode Setting Rotary Switch

Settings	Setup Description
4	Protocol mode in Form 4

◆ Communication Setting DIP Switch

DIP Switch	Settings	Setup Description
SW03	Unused	Unused
SW04	ON	Write setting during RUN whether enable or disable
SW05	OFF	Transmission speed setting
SW06	ON	
SW07	ON	
SW08	OFF	Data bit setting
SW09	ON	Parity bit setting whether enable or disable
SW10	ON	Parity setting whether Even or Odd
SW11	ON	Stop bit setting
SW12	ON	Sum check setting whether enable or disable

3.4 Setting Example 4

■ Settings of GP-Pro EX

◆ Communication Settings

To display the setup screen, from the [Project] menu, point to [System Settings] and select [Device/PLC].

◆ Device Setting

To display the [Individual Device Settings] dialog box, from [Device-Specific Settings] in the [Device/PLC] window, select the external device and click [Settings] .

To connect multiple External Devices, from [Device-Specific Settings] in the [Device/PLC] window, click [Add Device] to add another External Device.

■ Setting of External Device

Use the DIP switch of the Computer Link Unit for setting. Please refer to the manual of the External Device for more details.

◆ Mode Setting Rotary Switch

Settings	Setup Description
4	Protocol mode in Form 4

◆ Communication Setting DIP Switch

DIP Switch	Settings	Setup Description
SW11	OFF	Transmission speed setting
SW12	ON	
SW13	ON	
SW14	OFF	Data bit setting
SW15	ON	Parity bit setting whether enable or disable
SW16	ON	Parity setting whether Even or Odd
SW17	ON	Stop bit setting
SW18	ON	Sum check setting whether enable or disable
SW19	OFF	Main channel setting
SW20	ON	Write setting during RUN whether enable or disable

◆ Station Setting Rotary Switch

Rotary Switch	Settings	Setup Description
X10	0	Station No. setting
X1	0	

3.5 Setting Example 5

■ Settings of GP-Pro EX

◆ Communication Settings

To display the setup screen, from the [Project] menu, point to [System Settings] and select [Device/PLC].

Device/PLC 1

Summary [Change Device/PLC](#)

Manufacturer Series Port

Text Data Mode [Change](#)

Communication Settings

SID Type RS232C RS422/485(2wire) RS422/485(4wire)

Speed

Data Length 7 8

Parity NONE EVEN ODD

Stop Bit 1 2

Flow Control NONE ER(DTR/CTS) XON/XOFF

Timeout (sec)

Retry

Wait To Send (ms)

Format

RI / VCC RI VCC

In the case of RS232C, you can select the 9th pin to RI (Input) or VCC (5V Power Supply). If you use the Digital's RS232C Isolation Unit, please select it to VCC.

Device-Specific Settings

Allowable Number of Devices/PLCs 16 [Add Device](#)

No.	Device Name	Settings
1	PLC1	Station No.=0, PC No.=255

◆ Device Setting

To display the [Individual Device Settings] dialog box, from [Device-Specific Settings] in the [Device/PLC] window, select the external device and click [Settings] .

To connect multiple External Devices, from [Device-Specific Settings] in the [Device/PLC] window, click [Add Device] to add another External Device.

Individual Device Settings

PLC1

Station No.

PC No.

■ Setting of External Device

Use the DIP switch of the Computer Link Unit for setting. Please refer to the manual of the External Device for more details.

◆ Mode Setting Rotary Switch

Settings	Setup Description
8	Protocol mode in Form 4

◆ Communication Setting DIP Switch

DIP Switch	Settings	Setup Description
SW11	ON	Main channel setting
SW12	OFF	Data bit setting
SW13	OFF	Transmission speed setting
SW14	ON	
SW15	ON	
SW16	ON	Parity bit setting whether enable or disable
SW17	ON	Parity setting whether Even or Odd
SW18	ON	Stop bit setting
SW21	ON	Sum check setting whether enable or disable
SW22	ON	Write setting during RUN whether enable or disable
SW23	ON	Termination resistance on the sending side whether exist or not exist
SW24	ON	Termination resistance on the receiving side whether exist or not exist

◆ Station Setting Rotary Switch

Rotary Switch	Settings	Setup Description
X10	0	Station No. setting
X1	0	

3.6 Setting Example 6

■ Settings of GP-Pro EX

◆ Communication Settings

To display the setup screen, from the [Project] menu, point to [System Settings] and select [Device/PLC].

Device/PLC 1

Summary [Change Device/PLC](#)

Manufacturer Series Port

Text Data Mode [Change](#)

Communication Settings

SID Type RS232C RS422/485(2wire) RS422/485(4wire)

Speed

Data Length 7 8

Parity NONE EVEN ODD

Stop Bit 1 2

Flow Control NONE ER(DTR/CTS) XON/XOFF

Timeout (sec)

Retry

Wait To Send (ms)

Format

RI / VCC RI VCC

In the case of RS232C, you can select the 9th pin to RI (Input) or VCC (5V Power Supply). If you use the Digital's RS232C Isolation Unit, please select it to VCC.

Device-Specific Settings

Allowable Number of Devices/PLCs 16 [Add Device](#)

No.	Device Name	Settings
1	PLC1	Station No.=0,PC No.=255

◆ Device Setting

To display the [Individual Device Settings] dialog box, from [Device-Specific Settings] in the [Device/PLC] window, select the external device and click [Settings] .

To connect multiple External Devices, from [Device-Specific Settings] in the [Device/PLC] window, click [Add Device] to add another External Device.

Individual Device Settings

PLC1

Station No.

PC No.

■ Setting of External Device

Use the DIP switch of the Computer Link Unit for setting. Please refer to the manual of the External Device for more details.

◆ Mode Setting Rotary Switch

Settings	Setup Description
8	Protocol mode in Form 4

◆ Communication Setting DIP Switch

DIP Switch	Settings	Setup Description
SW11	ON	Main channel setting
SW12	OFF	Data bit setting
SW13	OFF	Transmission speed setting
SW14	ON	
SW15	ON	
SW16	ON	Parity bit setting whether enable or disable
SW17	ON	Parity setting whether Even or Odd
SW18	ON	Stop bit setting
SW21	ON	Sum check setting whether enable or disable
SW22	ON	Write setting during RUN whether enable or disable
SW23	ON	Computer link/Multiple drop link selection
SW24	Unused	Unused

◆ Station Setting Rotary Switch

Rotary Switch	Settings	Setup Description
X10	0	Station No. setting
X1	0	

3.7 Setting Example 7

■ Settings of GP-Pro EX

◆ Communication Settings

To display the setup screen, from the [Project] menu, point to [System Settings] and select [Device/PLC].

Device/PLC 1

Summary [Change Device/PLC](#)

Manufacturer Series Port

Text Data Mode [Change](#)

Communication Settings

SID Type RS232C RS422/485(2wire) RS422/485(4wire)

Speed

Data Length 7 8

Parity NONE EVEN ODD

Stop Bit 1 2

Flow Control NONE ER(DTR/CTS) XON/XOFF

Timeout (sec)

Retry

Wait To Send (ms)

Format

RI / VCC RI VCC

In the case of RS232C, you can select the 9th pin to RI (Input) or VCC (5V Power Supply). If you use the Digital's RS232C Isolation Unit, please select it to VCC.

Device-Specific Settings

Allowable Number of Devices/PLCs 16 [Add Device](#)

No.	Device Name	Settings
1	PLC1	Station No.=0, PC No.=255

◆ Device Setting

To display the [Individual Device Settings] dialog box, from [Device-Specific Settings] in the [Device/PLC] window, select the external device and click [Settings] .

To connect multiple External Devices, from [Device-Specific Settings] in the [Device/PLC] window, click [Add Device] to add another External Device.

Individual Device Settings

PLC1

Station No.

PC No.

■ Setting of External Device

Use the DIP switch of the Computer Link Unit for setting. Please refer to the manual of the External Device for more details.

◆ Mode Setting Rotary Switch

Settings	Setup Description
8	Protocol mode in Form 4

◆ Communication Setting DIP Switch

DIP Switch	Settings	Setup Description
SW01	Unused	Unused
SW02	ON	Computer link/Multiple drop link selection
SW03	Unused	Unused
SW04	ON	Write setting during RUN whether enable or disable
SW05	OFF	Transmission speed setting
SW06	ON	
SW07	ON	
SW08	OFF	Data bit setting
SW09	ON	Parity bit setting whether enable or disable
SW10	ON	Parity setting whether Even or Odd
SW11	ON	Stop bit setting
SW12	ON	Sum check setting whether enable or disable

◆ Station Setting Rotary Switch

Rotary Switch	Settings	Setup Description
X10	0	Station No. setting
X1	0	

3.8 Setting Example 8

■ Settings of GP-Pro EX

◆ Communication Settings

To display the setup screen, from the [Project] menu, point to [System Settings] and select [Device/PLC].

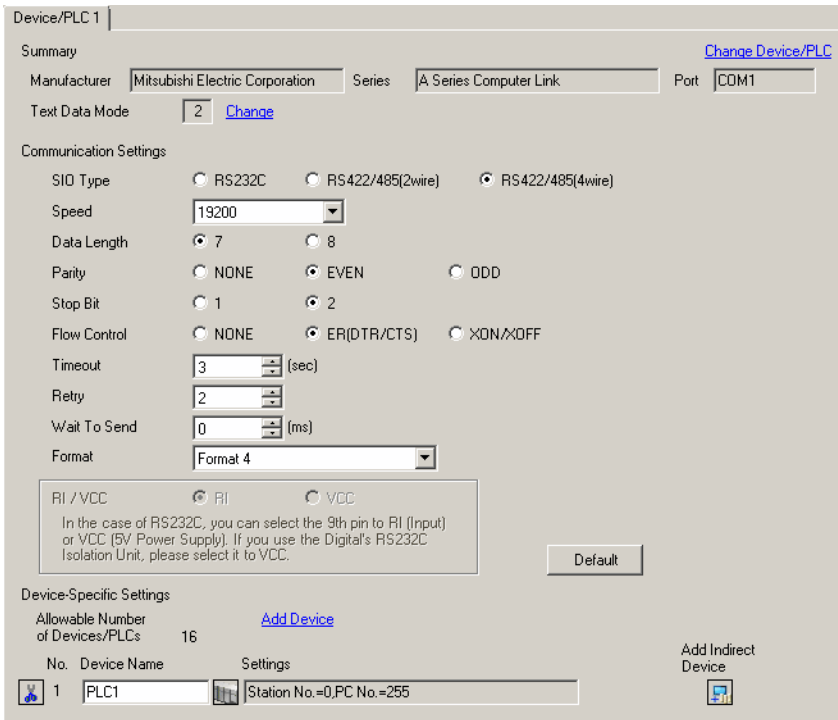

◆ Device Setting

To display the [Individual Device Settings] dialog box, from [Device-Specific Settings] in the [Device/PLC] window, select the external device and click [Settings] .

To connect multiple External Devices, from [Device-Specific Settings] in the [Device/PLC] window, click [Add Device] to add another External Device.

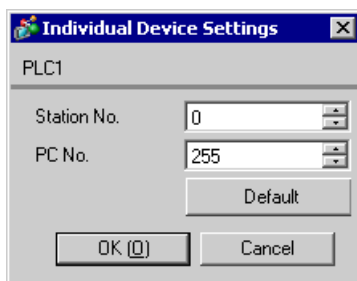

■ Setting of External Device

Use the DIP switch of the Computer Link Unit for setting. Please refer to the manual of the External Device for more details.

◆ Mode Setting Rotary Switch

Settings	Setup Description
8	Protocol mode in Form 4

◆ Communication Setting DIP Switch

DIP Switch	Settings	Setup Description
SW10	ON	Computer link/Multiple drop link selection
SW11	ON	Main channel setting
SW12	ON	Write setting during RUN whether enable or disable
SW13	OFF	Transmission speed setting
SW14	ON	
SW15	ON	
SW16	OFF	Data bit setting
SW17	ON	Parity bit setting whether enable or disable
SW18	ON	Parity setting whether Even or Odd
SW19	ON	Stop bit setting
SW20	ON	Sum check setting whether enable or disable

◆ Termination resistance DIP switch

DIP Switch	Settings	Setup Description
SW21	OFF	Unused
SW22	Option	Termination resistance on the sending side
SW23	Option	Termination resistance on the receiving side

◆ Station Setting Rotary Switch

Rotary Switch	Settings	Setup Description
X10	0	Station No. setting
X1	0	

4 Setup Items

Set communication settings of the Display with GP-Pro Ex or in offline mode of the Display.

The setting of each parameter must be identical to that of External Device.

☞ "3 Example of Communication Setting" (page 11)

4.1 Setup Items in GP-Pro EX

■ Communication Settings

To display the setup screen, from the [Project] menu, point to [System Settings] and select [Device/PLC].

Setup Items	Setup Description
SIO Type	Select the SIO type to communicate with the External Device.
Speed	Select speed between the External Device and the Display.
Data Length	Select data length.
Parity	Select how to check parity.
Stop Bit	Select stop bit length.
Flow Control	Select the communication control method to prevent overflow of transmission and reception data.
Timeout	Use an integer from 1 to 127 to enter the time (s) for which the Display waits for the response from the External Device. <div style="border: 1px solid black; padding: 2px; display: inline-block; margin: 5px 0;">IMPORTANT</div> <ul style="list-style-type: none"> Set the value to 5 seconds or more when you communicate via network.

continued to next page

Setup Items	Setup Description
Retry	In case of no response from the External Device, use an integer from 0 to 255 to enter how many times the Display retransmits the command.
Wait To Send	Use an integer from 0 to 255 to enter standby time (ms) for the Display from receiving packets to transmitting next commands.
Format	Select the dedicated protocol format to use, from "Format 4" or "Format 1". NOTE When using serial multilink, select "Format 4".
RI/VCC	You can switch RI/VCC of the 9th pin when you select RS232C for SIO type. It is necessary to change RI/5V by changeover switch of IPC when connect with IPC. Please refer to the manual of the IPC for more detail.

NOTE

- Refer to the GP-Pro EX Reference Manual for Indirect Device.
Cf. GP-Pro EX Reference Manual "Changing the Device/PLC at Runtime (Indirect Device)"

■ Device Setting

To display the [Individual Device Settings] dialog box, from [Device-Specific Settings] in the [Device/PLC] window, select the external device and click [Settings] .

To connect multiple External Devices, from [Device-Specific Settings] in the [Device/PLC] window, click [Add Device] to add another External Device.

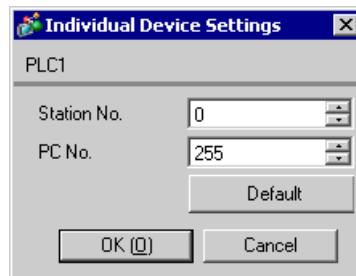

Setup Items	Setup Description
Station No.	Enter a station number of the External Device, using 0 to 31.
PC No.	Set when you communicate via network. Use an integer from 0 to 64 to enter PC No. of the External Device to communicate. If you do not communicate via network, enter 255.

4.2 Setup Items in Offline Mode

NOTE

- Refer to the Maintenance/Troubleshooting guide for information on how to enter offline mode or about the operation.

Cf. Maintenance/Troubleshooting Guide "Offline Mode"

- The number of the setup items to be displayed for 1 page in the offline mode depends on the Display in use. Please refer to the Reference manual for details.

■ Communication Settings

To display the setting screen, touch [Device/PLC Settings] from [Peripheral Settings] in offline mode. Touch the External Device you want to set from the displayed list.

Comm.	Device	Option		
A Series Computer Link		[COM1]	Page 1/1	
SIO Type	RS232C			
Speed	19200			
Data Length	<input checked="" type="radio"/> 7 <input type="radio"/> 8			
Parity	<input type="radio"/> NONE <input checked="" type="radio"/> EVEN <input type="radio"/> ODD			
Stop Bit	<input type="radio"/> 1 <input checked="" type="radio"/> 2			
Flow Control	ER(DTR/CTS)			
Timeout(s)	3			
Retry	2			
Wait To Send(ms)	0			
Format	Format 4			
Exit		Back		2017/11/09 11:03:35

Setup Items	Setup Description
SIO Type	Select the SIO type to communicate with the External Device. IMPORTANT To make the communication settings correctly, confirm the serial interface specifications of Display unit for [SIO Type]. We cannot guarantee the operation if a communication type that the serial interface does not support is specified. For details concerning the serial interface specifications, refer to the manual for Display unit.
Speed	Select speed between the External Device and the Display.
Data Length	Select data length.
Parity	Select how to check parity.
Stop Bit	Select stop bit length.
Flow Control	Select the communication control method to prevent overflow of transmission and reception data.

continued to next page

Setup Items	Setup Description
Timeout (s)	Use an integer from 1 to 127 to enter the time (s) for which the Display waits for the response from the External Device. IMPORTANT • Set the value to 5 seconds or more when you communicate via network.
Retry	In case of no response from the External Device, use an integer from 0 to 255 to enter how many times the Display retransmits the command.
Wait To Send (ms)	Use an integer from 0 to 255 to enter standby time (ms) for the Display from receiving packets to transmitting next commands.
Format	Select the dedicated protocol format to use, from "Format 4" or "Format 1". NOTE When using serial multilink, select "Format 4".

■ Device Setting

To display the setting screen, touch [Device/PLC Settings] from [Peripheral Settings]. Touch the External Device you want to set from the displayed list, and touch [Device].

Comm.	Device	Option		
A Series Computer Link		[COM1]	Page 1/1	
Device/PLC Name		[PLC1] ▼		
Station No.		0	▼	▲
PC No.		255	▼	▲
Exit		Back		2017/11/09 11:03:39

Setup Items	Setup Description
Device/PLC Name	Select the External Device for device setting. Device name is a title of External Device set with GP-Pro EX.(Initial value [PLC1])
Station No.	Enter a station number of the External Device, using 0 to 31.
PC No.	Set when you communicate via network. Use an integer from 0 to 64 to enter PC No. of the External Device to communicate. If you do not communicate via network, enter 255.

■ Option

To display the setting screen, touch [Device/PLC Settings] from [Peripheral Settings]. Touch the External Device you want to set from the displayed list, and touch [Option].

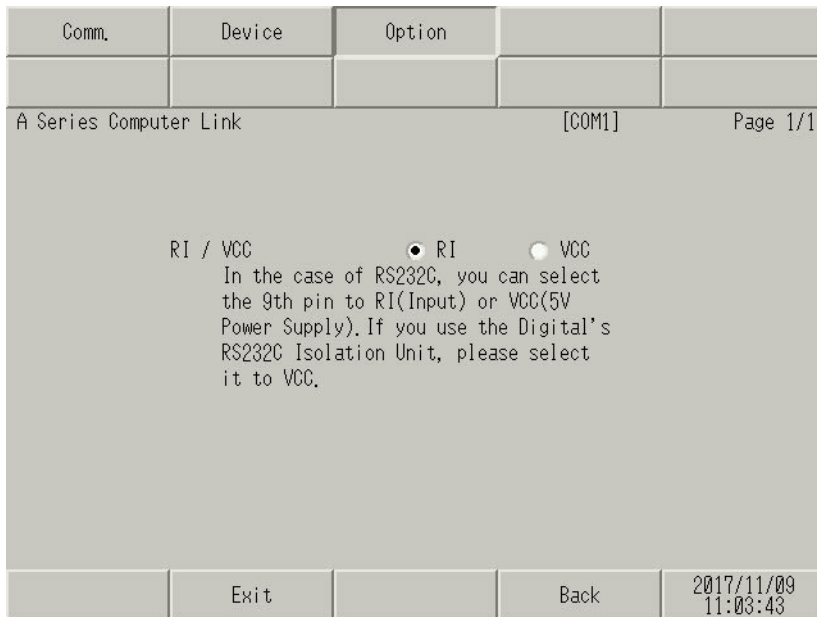

Setup Items	Setup Description
RI/VCC	You can switch RI/VCC of the 9th pin when you select RS232C for SIO type. It is necessary to change RI/5V by changeover switch of IPC when connect with IPC. Please refer to the manual of the IPC for more detail.

- NOTE**
- GP-4100 series, GP-4*01TM and GP-Rear Module do not have the [Option] setting in the offline mode.

5 Cable Diagram

The cable diagram shown below may be different from the cable diagram recommended by Mitsubishi Electric Corporation. Please be assured there is no operational problem in applying the cable diagram shown in this manual.

- The FG pin of the External Device body must be D-class grounded. Please refer to the manual of the External Device for more details.
- SG and FG are connected inside the Display. When connecting SG to the External Device, design the system not to form short-circuit loop.
- Connect the isolation unit, when communication is not stabilized under the influence of a noise etc..

Cable Diagram 1

Display (Connection Port)	Cable		Notes
GP3000 (COM1) GP4000* ¹ (COM1) SP5000* ² (COM1/2)	1A	RS232C cable by Pro-face CA3-CBL232/5M-01 (5m)	
SP-5B00 (COM1) ST3000 (COM1) ST6000 (COM1) STM6000 (COM1) STC6000 (COM1) ET6000 (COM1) LT3000 (COM1) IPC* ³ PC/AT	1B	User-created cable	The cable length must be 15m or less.
GP-4105 (COM1) GP-4115T (COM1) GP-4115T3 (COM1)	1C	User-created cable	The cable length must be 15m or less.

*1 All GP4000 models except GP-4100 Series and GP-4203T

*2 Except SP-5B00

*3 Only the COM port which can communicate by RS-232C can be used.

 ■ IPC COM Port (page 7)

1A)

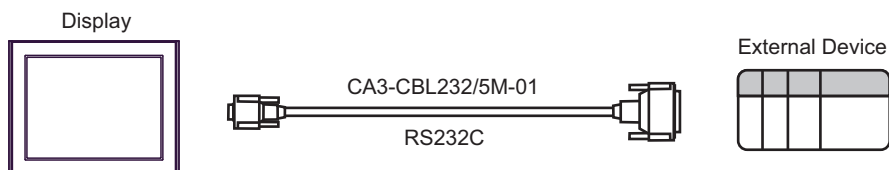

1B)

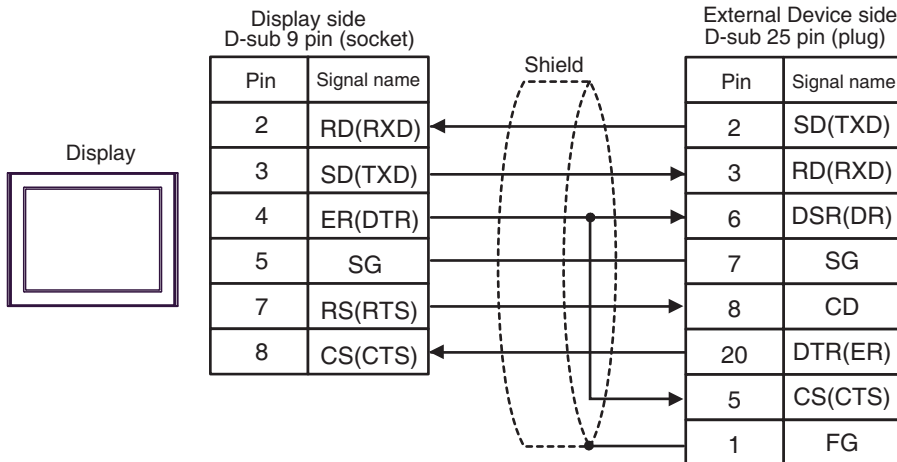

1C)

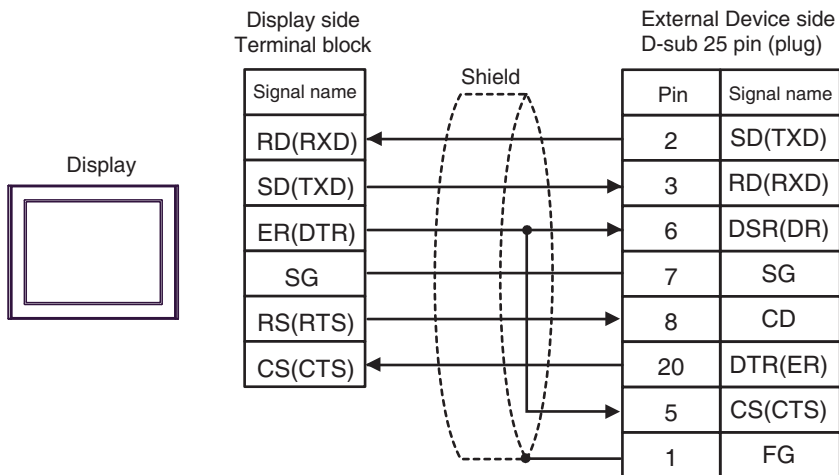

Cable Diagram 2

Display (Connection Port)	Cable		Notes
GP3000* ¹ (COM1) AGP-3302B (COM2) GP-4*01TM (COM1) GP-Rear Module (COM1) ST3000* ² (COM2) LT3000 (COM1) IPC* ³	2A	COM port conversion adapter by Pro-face CA3-ADPCOM-01 + Terminal block conversion adapter by Pro-face CA3-ADPTRM-01 + User-created cable	The cable length must be 500m or less.
	2B	User-created cable	
GP3000* ⁴ (COM2)	2C	Online adapter by Pro-face CA4-ADPONL-01 + Terminal block conversion adapter by Pro-face CA3-ADPTRM-01 + User-created cable	The cable length must be 500m or less.
	2D	Online adapter by Pro-face CA4-ADPONL-01 + User-created cable	
GP-4106 (COM1) GP-4116T (COM1)	2E	User-created cable	The cable length must be 500m or less.
GP4000* ⁵ (COM2) GP-4201T (COM1) SP5000* ⁶ (COM1/2) SP-5B00 (COM2) ST6000* ⁷ (COM2) ST-6200 (COM1) STM6000 (COM1) STC6000 (COM1) ET6000* ⁸ (COM2) PS6000 (Basic Box) (COM1/2)	2F	RS-422 terminal block conversion adapter by Pro-face PFXZCBADTM1* ⁹ + User-created cable	The cable length must be 500m or less.
	2B	User-created cable	
PE-4000B* ¹⁰ PS5000* ¹⁰ PS6000 (Optional Interface)* ¹⁰	2G	User-created cable	The cable length must be 500m or less.

*1 All GP3000 models except AGP-3302B

*2 Except AST-3211A and AST-3302B

*3 Only the COM port which can communicate by RS-422/485 (4 wire) can be used. (Except PE-4000B, PS5000, and PS6000)

 ■ IPC COM Port (page 7)

*4 All GP3000 models except GP-3200 series and AGP-3302B

*5 All GP4000 models except GP-4100 series, GP-4*01TM, GP-Rear Module, GP-4201T and GP-4*03T

*6 Except SP-5B00

- *7 Except ST-6200
- *8 Due to the COM port specifications, flow control is not possible. Omit wiring the control pins on the Display side of the cable diagram.
- *9 When using a Terminal Block Conversion Adapter (CA3-ADPTRM-01) instead of the RS-422 Terminal Block Conversion Adapter, refer to Cable Diagram 2A.
- *10 Only the COM port which can communicate by RS-422/485 (4 wire) can be used.
 - ☞ ■ IPC COM Port (page 7)

NOTE

- In order to improve noise resistance characteristics, please use a twist pair whole shield cable as a transmission cable and ground the shield line.
-

2A)

- 1:1 Connection

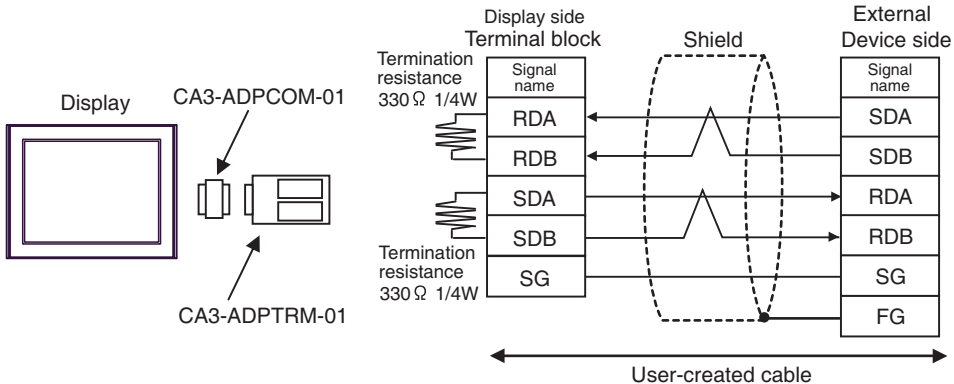

- 1:n Connection

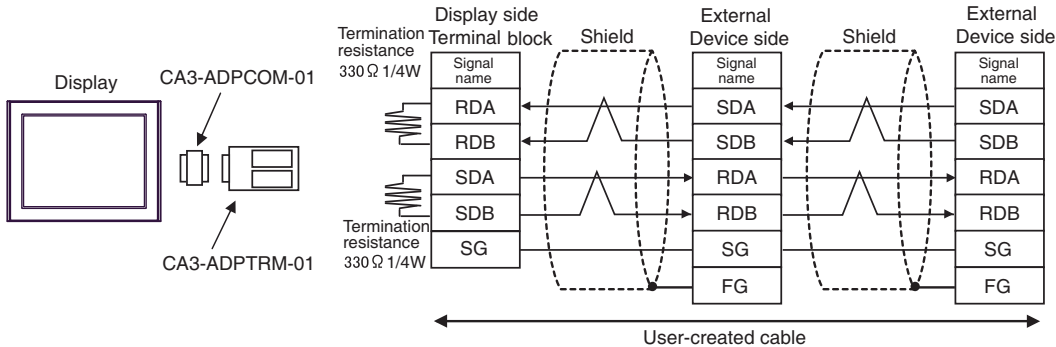

IMPORTANT

- The termination resistance of 330Ω/1/4W is required between SDA-SDB and RDA-RDB in the unit on the terminatory External Device.
- When the termination resistance is attached to the unit, you can turn ON the switch to load the termination resistance. Please refer to the manual of the External Device for more details.

2B)

- 1:1 Connection

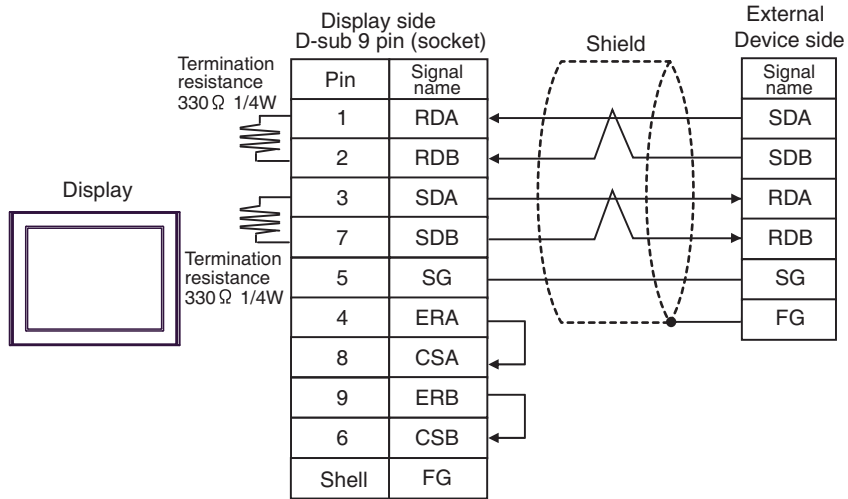

- 1:n Connection

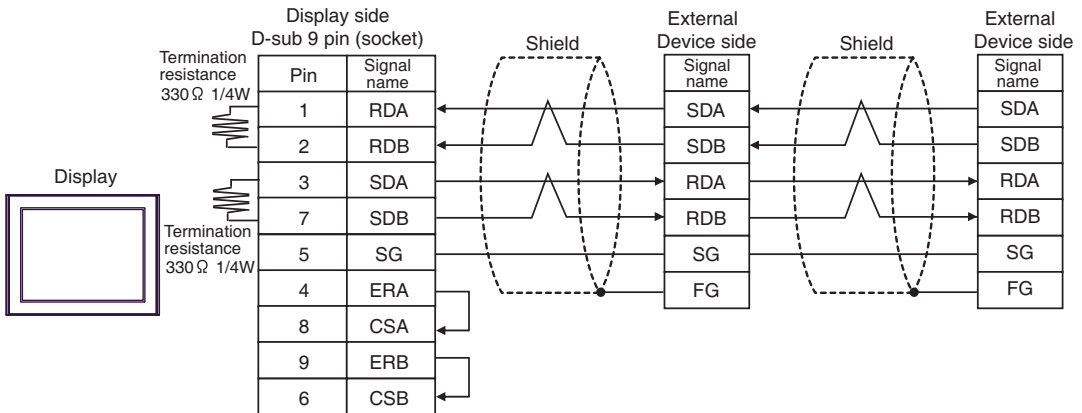

IMPORTANT

- The termination resistance of 330Ω1/4W is required between SDA-SDB and RDA-RDB in the unit on the terminatory External Device.
- When the termination resistance is attached to the unit, you can turn ON the switch to load the termination resistance. Please refer to the manual of the External Device for more details.

2C)

- 1:1 Connection

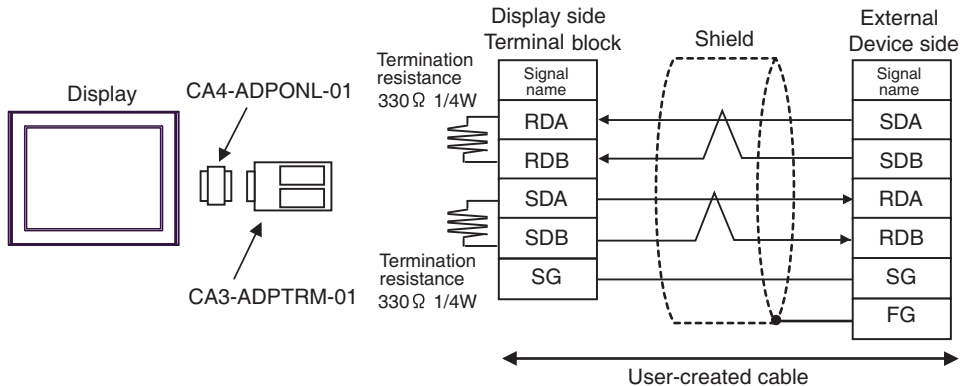

- 1:n Connection

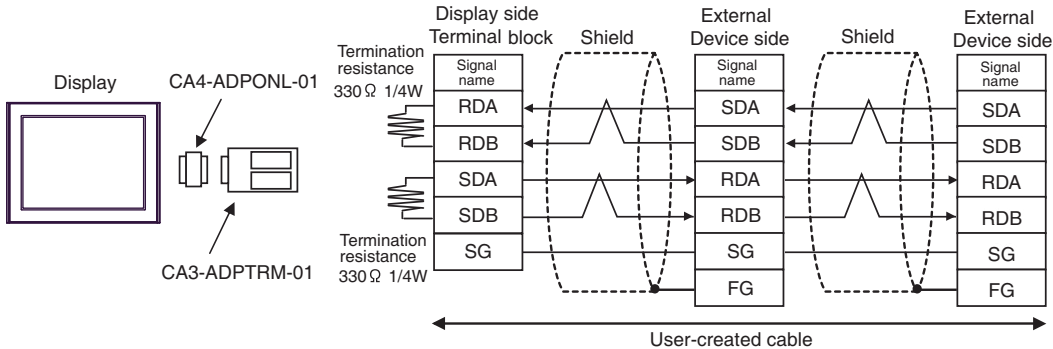

IMPORTANT

- The termination resistance of 330Ω1/4W is required between SDA-SDB and RDA-RDB in the unit on the terminatory External Device.
- When the termination resistance is attached to the unit, you can turn ON the switch to load the termination resistance. Please refer to the manual of the External Device for more details.

2D)

- 1:1 Connection

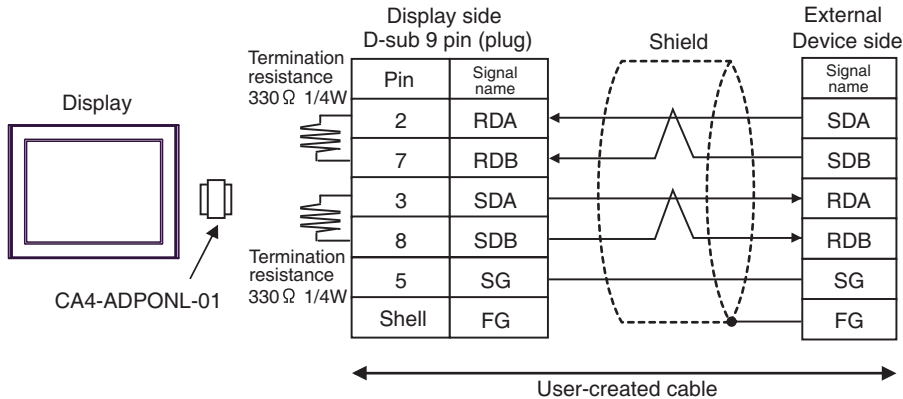

- 1:n Connection

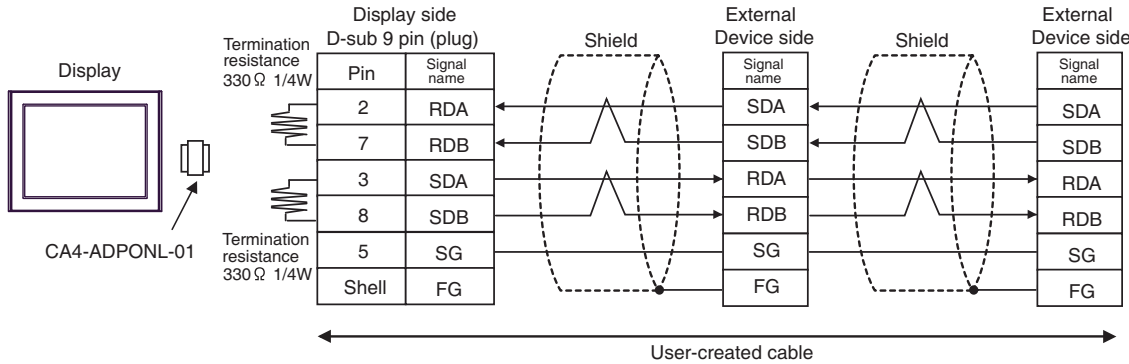

IMPORTANT

- The termination resistance of 330Ω1/4W is required between SDA-SDB and RDA-RDB in the unit on the terminatory External Device.
- When the termination resistance is attached to the unit, you can turn ON the switch to load the termination resistance. Please refer to the manual of the External Device for more details.

2E)

- 1:1 Connection

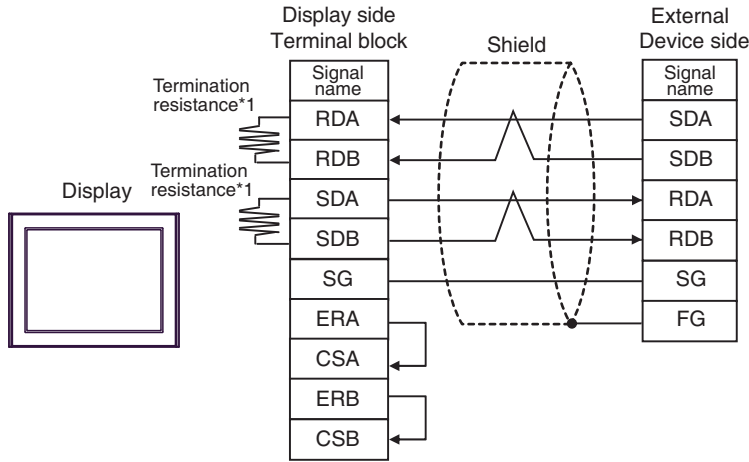

- 1:n Connection

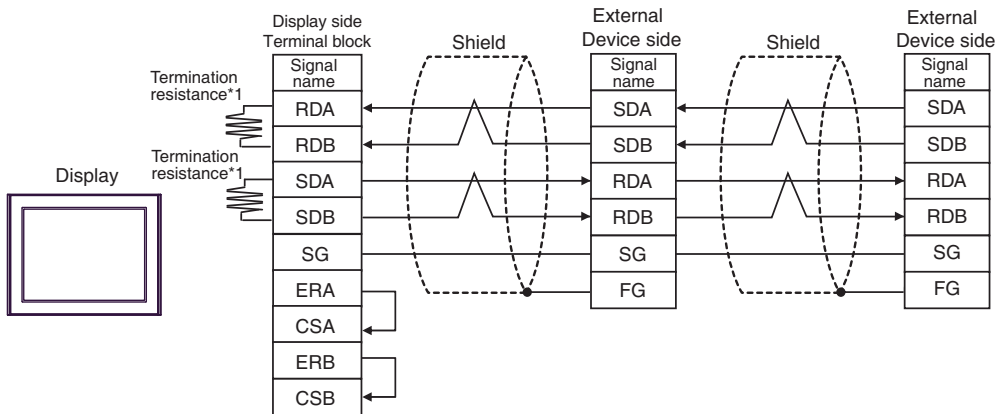

IMPORTANT

- The termination resistance of 330Ω1/4W is required between SDA-SDB and RDA-RDB in the unit on the terminatory External Device.
- When the termination resistance is attached to the unit, you can turn ON the switch to load the termination resistance. Please refer to the manual of the External Device for more details.

*1 The resistance in the Display is used as the termination resistance. Set the value of the DIP Switch on the rear of the Display as shown in the table below.

DIP Switch No.	Set Value
1	ON
2	OFF
3	ON
4	OFF

2F)

- 1:1 Connection

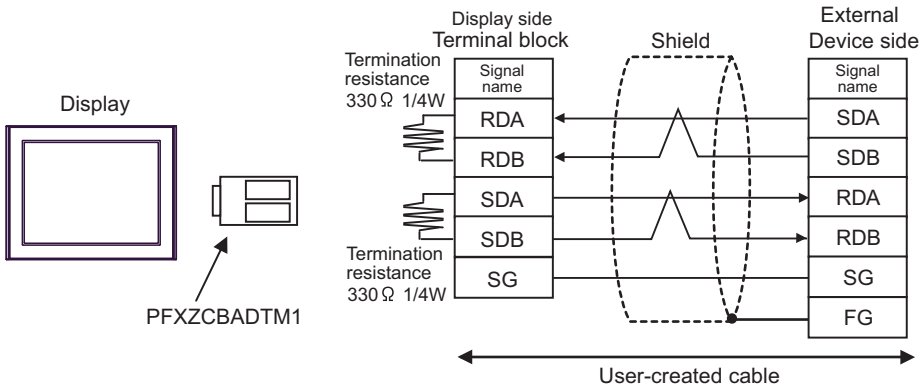

- 1:n Connection

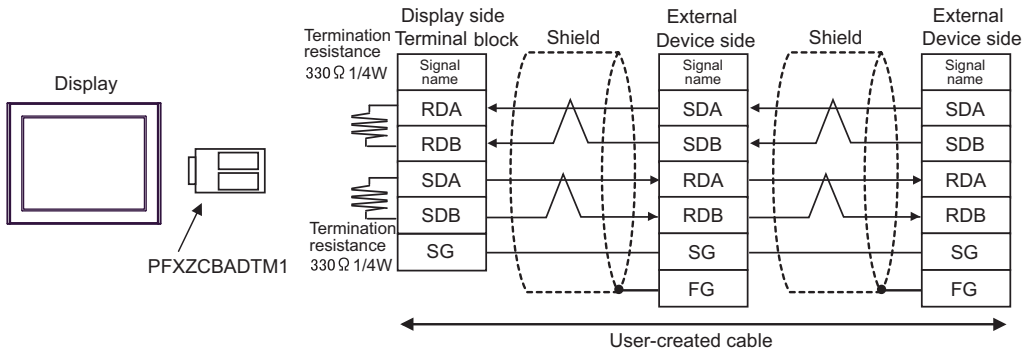

IMPORTANT

- The termination resistance of 330Ω1/4W is required between SDA-SDB and RDA-RDB in the unit on the terminatory External Device.
- When the termination resistance is attached to the unit, you can turn ON the switch to load the termination resistance. Please refer to the manual of the External Device for more details.

2G)

- 1:1 Connection

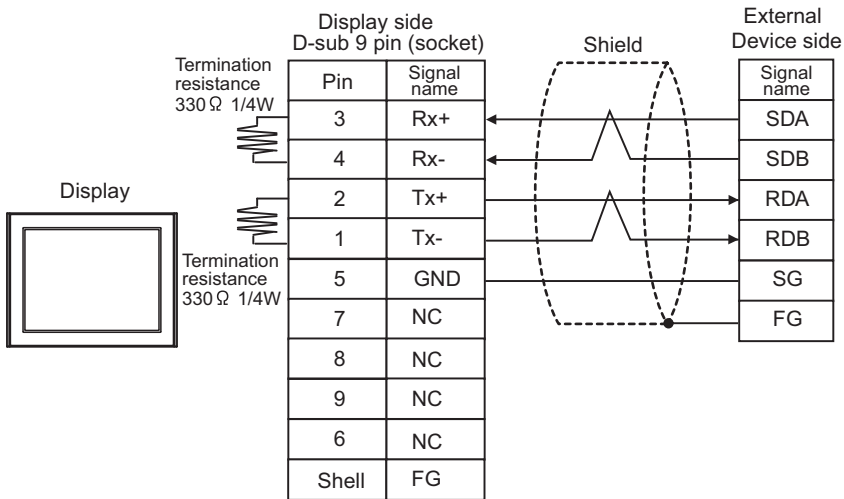

- 1:n Connection

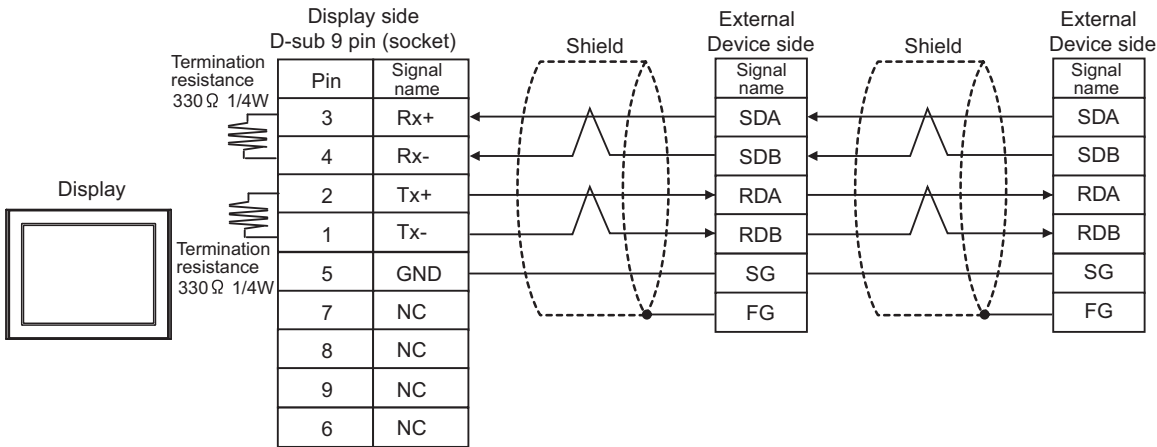

IMPORTANT

- The termination resistance of 330Ω1/4W is required between SDA-SDB and RDA-RDB in the unit on the terminatory External Device.
- When the termination resistance is attached to the unit, you can turn ON the switch to load the termination resistance. Please refer to the manual of the External Device for more details.

Cable Diagram 3

Display (Connection Port)	Cable		Notes
GP3000 (COM1) GP4000* ¹ (COM1) SP5000* ² (COM1/2) SP-5B00 (COM1) ST3000 (COM1) ST6000 (COM1) STM6000 (COM1) STC6000 (COM1) ET6000 (COM1) LT3000 (COM1) IPC* ³ PC/AT	3A	Mitsubishi Q link cable by Pro-face CA3-CBLLNKMQ-01 (5m)	
	3B	User-created cable	The cable length must be 15m or less.
GP-4105 (COM1) GP-4115T (COM1) GP-4115T3 (COM1)	3C	User-created cable	The cable length must be 15m or less.

- *1 All GP4000 models except GP-4100 Series and GP-4203T
- *2 Except SP-5B00
- *3 Only the COM port which can communicate by RS-232C can be used.
 ■ IPC COM Port (page 7)

3A)

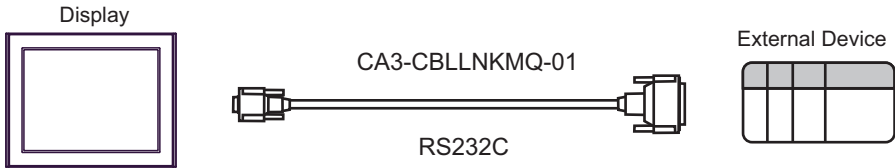

3B)

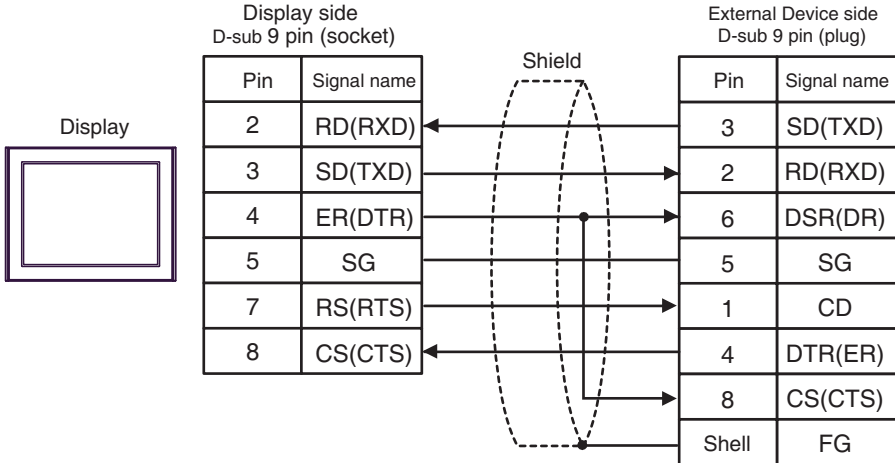

3C)

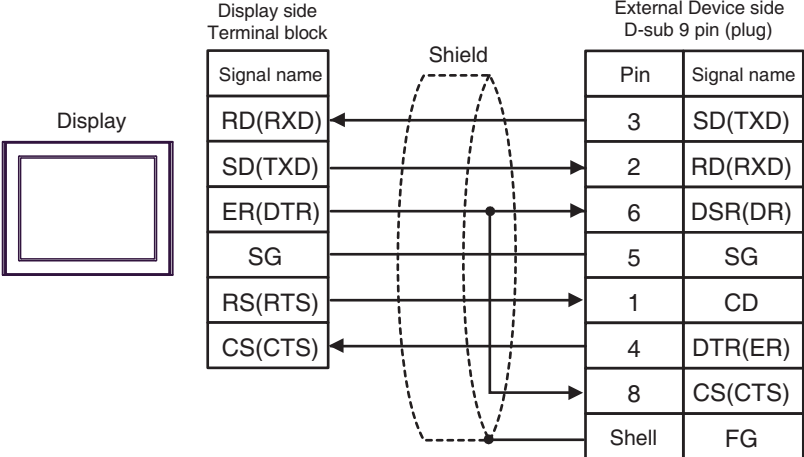

Cable Diagram 4

Display (Connection Port)	Cable		Notes
GP3000* ¹ (COM1) AGP-3302B (COM2) GP-4*01TM (COM1) GP-Rear Module (COM1) ST3000* ² (COM2) LT3000 (COM1) IPC* ³	4A	COM port conversion adapter by Pro-face CA3-ADPCOM-01 + Connector terminal block conversion adapter by Pro-face CA3-ADPTRM-01 + User-created cable	The cable length must be 500m or less.
	4B	COM port conversion adapter by Pro-face CA3-ADPCOM-01 + Multilink cable by Pro-face CA3-CBLMLT-01 + User-created cable	
	4C	User-created cable	
GP3000* ⁴ (COM2)	4D	Online adapter by Pro-face CA4-ADPONL-01 + Connector terminal block conversion adapter by Pro-face CA3-ADPTRM-01 + User-created cable	The cable length must be 500m or less.
	4E	Online adapter by Pro-face CA4-ADPONL-01 + Multilink cable by Pro-face CA3-CBLMLT-01 + User-created cable	
	4F	Online adapter by Pro-face CA4-ADPONL-01 + User-created cable	
GP-4106 (COM1) GP-4116T (COM1)	4G	User-created cable	The cable length must be 500m or less.

Display (Connection Port)	Cable		Notes
GP4000 ^{*5} (COM2) GP-4201T (COM1) SP5000 ^{*6} (COM1/2) SP-5B00 (COM2) ST6000 ^{*7} (COM2) ST-6200 (COM1) STM6000 (COM1) STC6000 (COM1) ET6000 ^{*8} (COM2) PS6000 (Basic Box) (COM1/2)	4H	RS-422 terminal block conversion adapter by Pro-face PFXZCBADTM1 ^{*9} + User-created cable	The cable length must be 500m or less.
	4I	Multilink cable by Pro-face PFXZCBCBML1 ^{*10} + User-created cable	
	4C	User-created cable	
PE-4000B ^{*11} PS5000 ^{*11} PS6000 (Optional Interface) ^{*11}	4J	User-created cable	The cable length must be 500m or less.

*1 All GP3000 models except AGP-3302B

*2 Except AST-3211A and AST-3302B

*3 Only the COM port which can communicate by RS-422/485 (4 wire) can be used. (Except PE-4000B, PS5000, and PS6000)

 ■ IPC COM Port (page 7)

*4 All GP3000 models except GP-3200 series and AGP-3302B

*5 All GP4000 models except GP-4100 series, GP-4*01TM, GP-Rear Module, GP-4201T and GP-4*03T

*6 Except SP-5B00

*7 Except ST-6200

*8 Due to the COM port specifications, flow control is not possible. Omit wiring the control pins on the Display side of the cable diagram.

*9 When using a Terminal Block Conversion Adapter (CA3-ADPTRM-01) instead of the RS-422 Terminal Block Conversion Adapter, refer to Cable Diagram 4A.

*10 When using a Multilink Cable (CA3-CBLMLT-01) instead of the Multilink Cable, refer to Cable Diagram 4B.

*11 Only the COM port which can communicate by RS-422/485 (4 wire) can be used.

 ■ IPC COM Port (page 7)

4A)

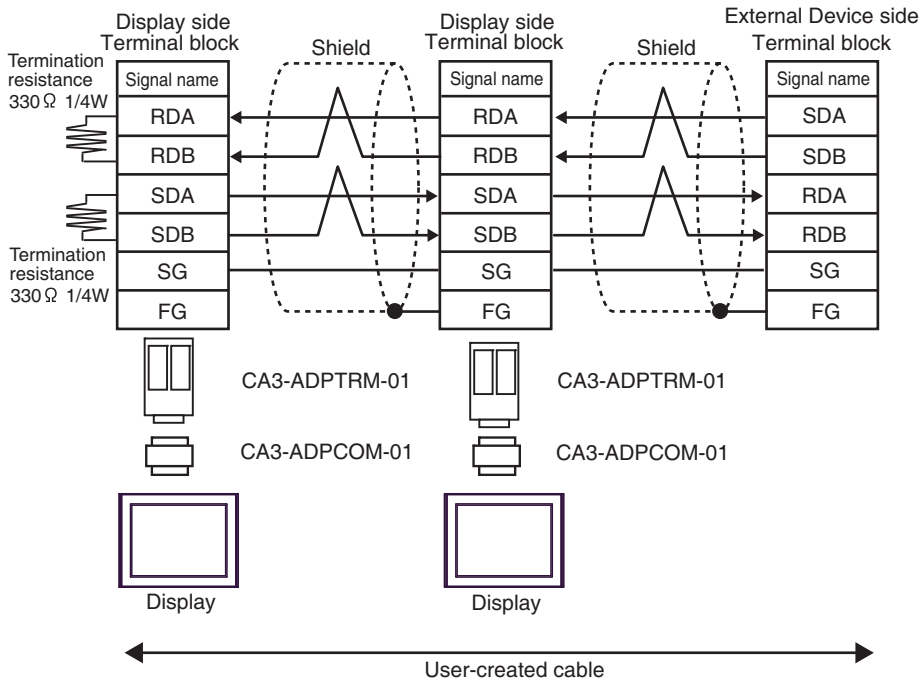

IMPORTANT

- The termination resistance of 330Ω/1/4W is required between SDA-SDB and RDA-RDB in the unit on the terminatory External Device.
- When the termination resistance is attached to the unit, you can turn ON the switch to load the termination resistance. Please refer to the manual of the External Device for more details.

4B)

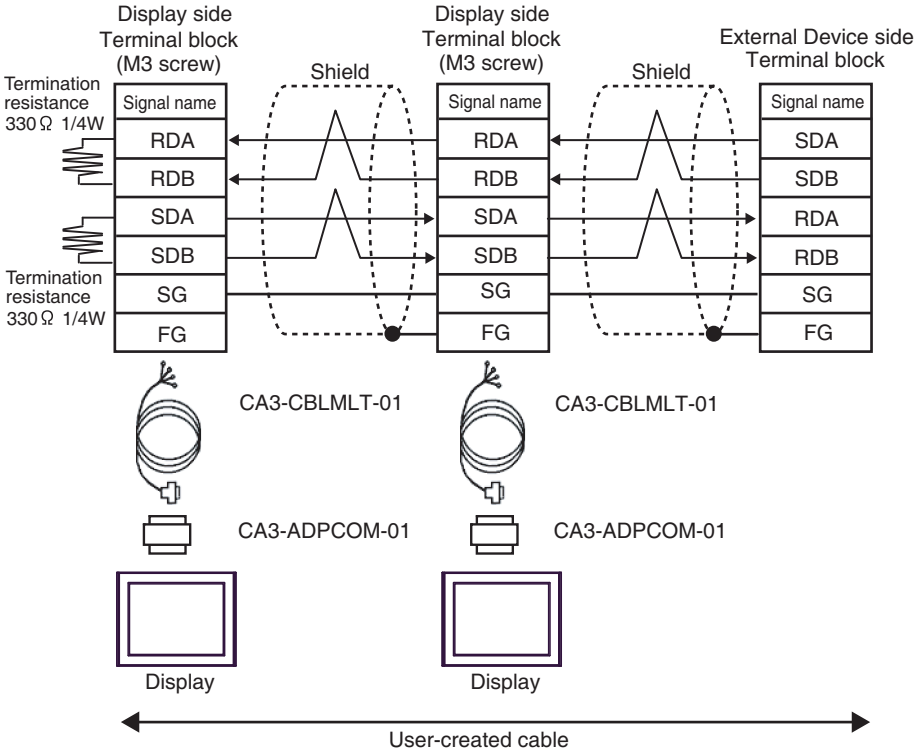

- IMPORTANT**
- The termination resistance of 330Ω1/4W is required between SDA-SDB and RDA-RDB in the unit on the terminatory External Device.
 - When the termination resistance is attached to the unit, you can turn ON the switch to load the termination resistance. Please refer to the manual of the External Device for more details.

4C)

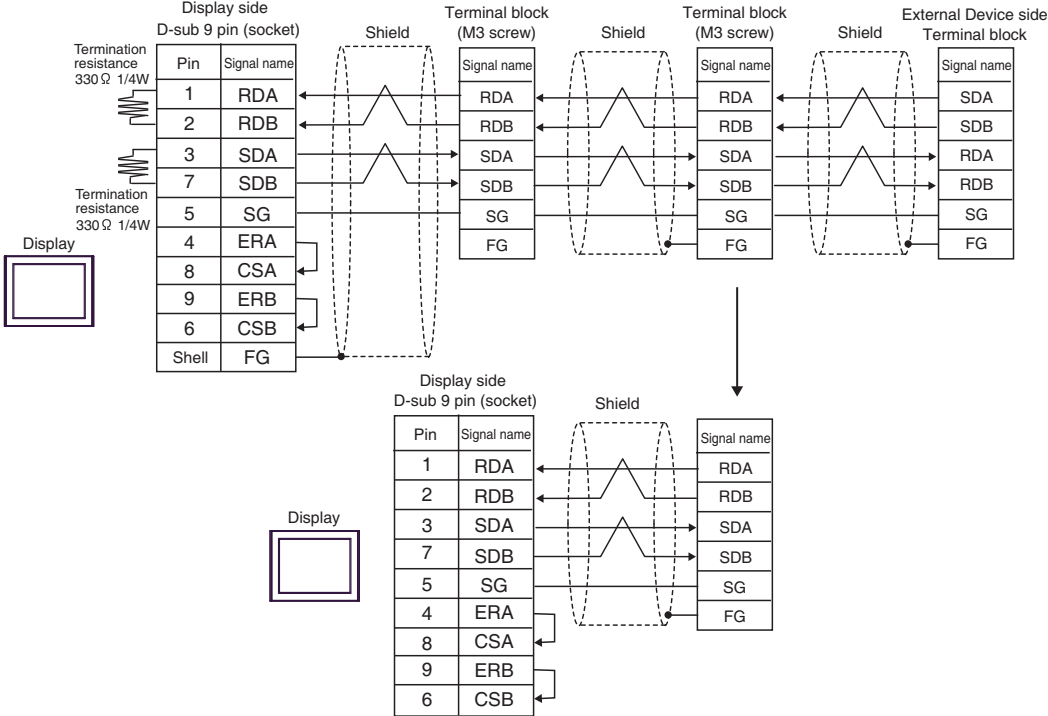

IMPORTANT

- The termination resistance of 330Ω1/4W is required between SDA-SDB and RDA-RDB in the unit on the terminatory External Device.
- When the termination resistance is attached to the unit, you can turn ON the switch to load the termination resistance. Please refer to the manual of the External Device for more details.

4D)

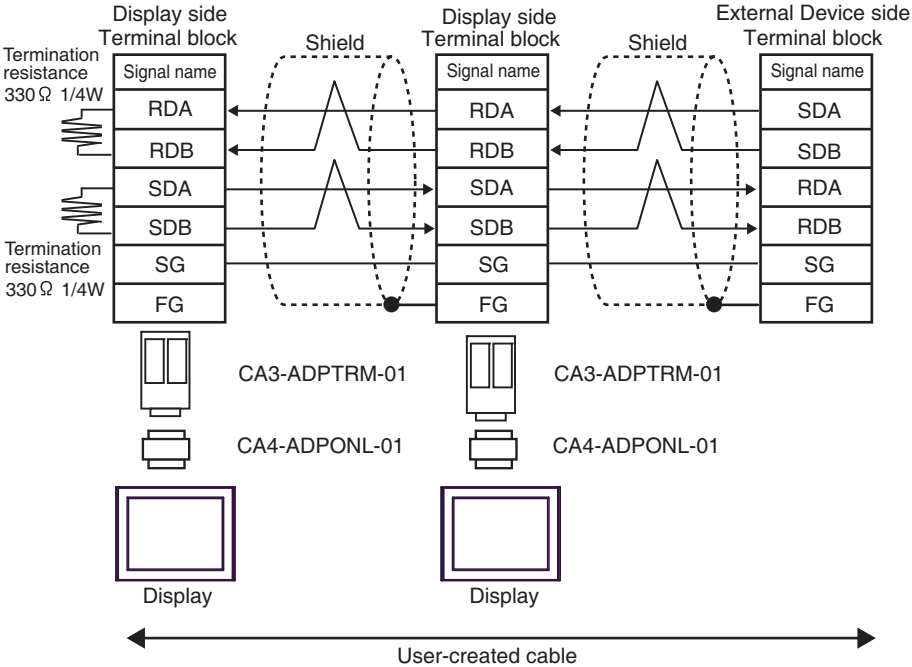

IMPORTANT

- The termination resistance of 330Ω/1/4W is required between SDA-SDB and RDA-RDB in the unit on the terminatory External Device.
- When the termination resistance is attached to the unit, you can turn ON the switch to load the termination resistance. Please refer to the manual of the External Device for more details.

4E)

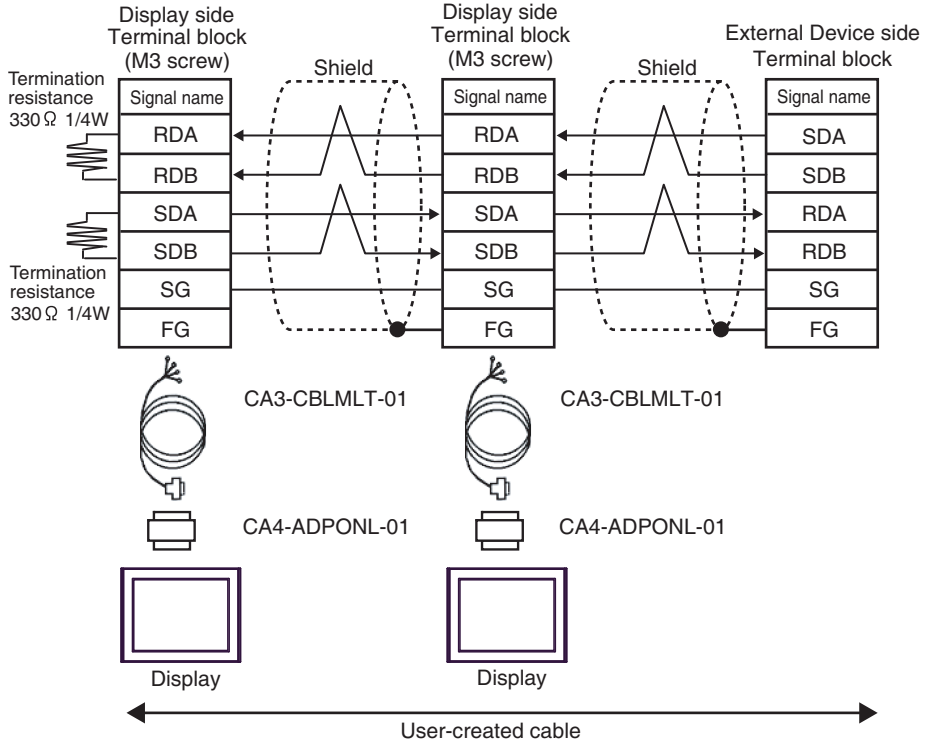

IMPORTANT

- The termination resistance of 330Ω1/4W is required between SDA-SDB and RDA-RDB in the unit on the terminatory External Device.
- When the termination resistance is attached to the unit, you can turn ON the switch to load the termination resistance. Please refer to the manual of the External Device for more details.

4F)

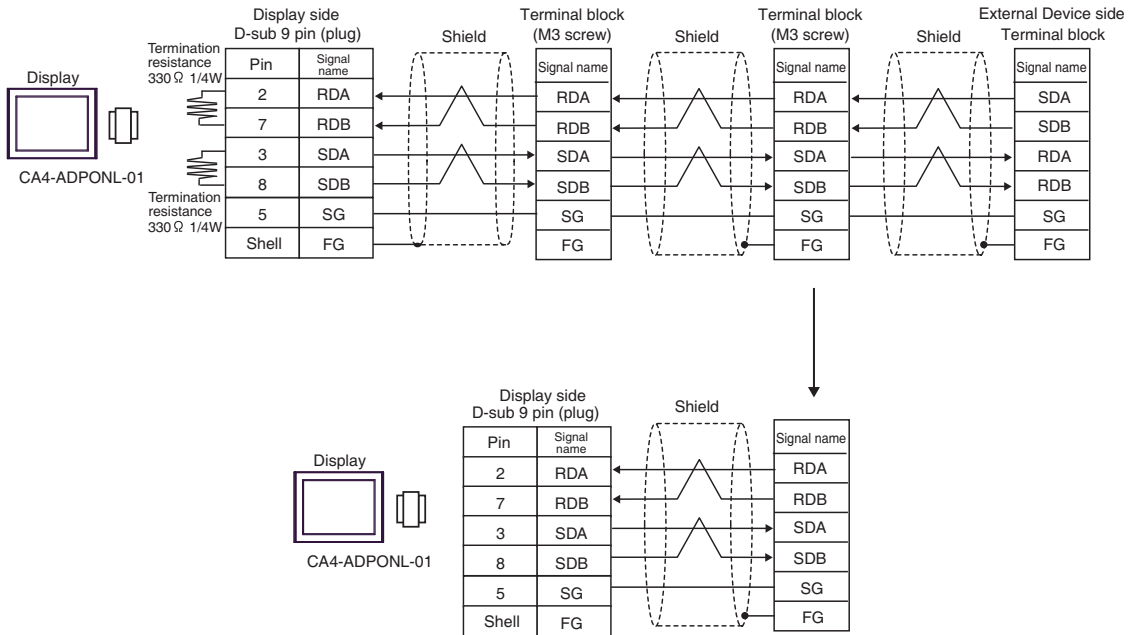

IMPORTANT

- The termination resistance of 330Ω1/4W is required between SDA-SDB and RDA-RDB in the unit on the terminatory External Device.
- When the termination resistance is attached to the unit, you can turn ON the switch to load the termination resistance. Please refer to the manual of the External Device for more details.

4G)

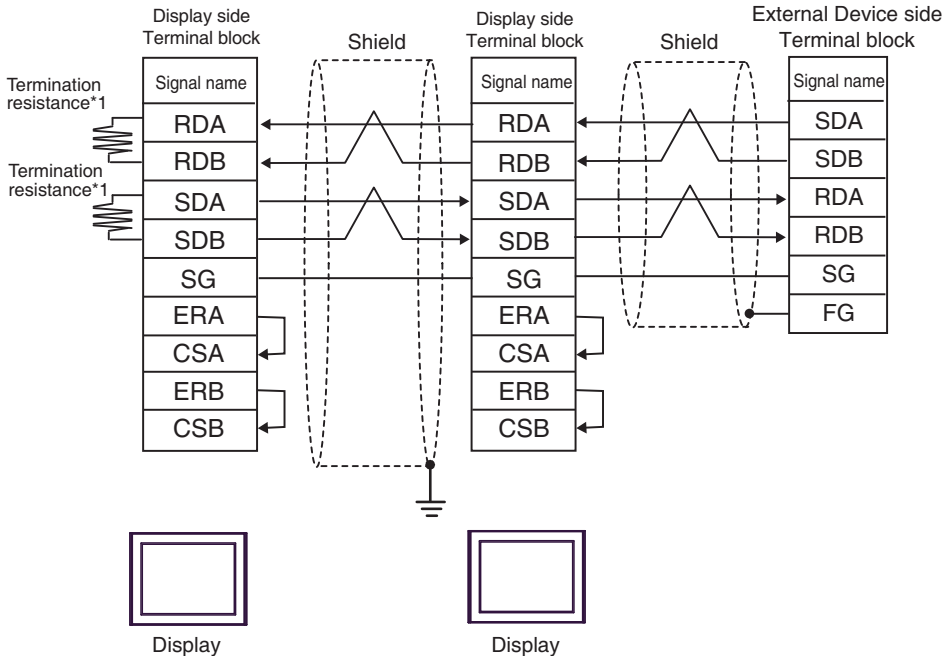

IMPORTANT

- The termination resistance of 330Ω1/4W is required between SDA-SDB and RDA-RDB in the unit on the terminatory External Device.
- When the termination resistance is attached to the unit, you can turn ON the switch to load the termination resistance. Please refer to the manual of the External Device for more details.

*1 The resistance in the Display is used as the termination resistance. Set the value of the DIP Switch on the rear of the Display as shown in the table below.

DIP Switch No.	Set Value
1	ON
2	OFF
3	ON
4	OFF

For the Displays other than that used as the terminal, set the DIP Switch 1-4 on the rear of the Display to OFF in the n:1 connection.

4H)

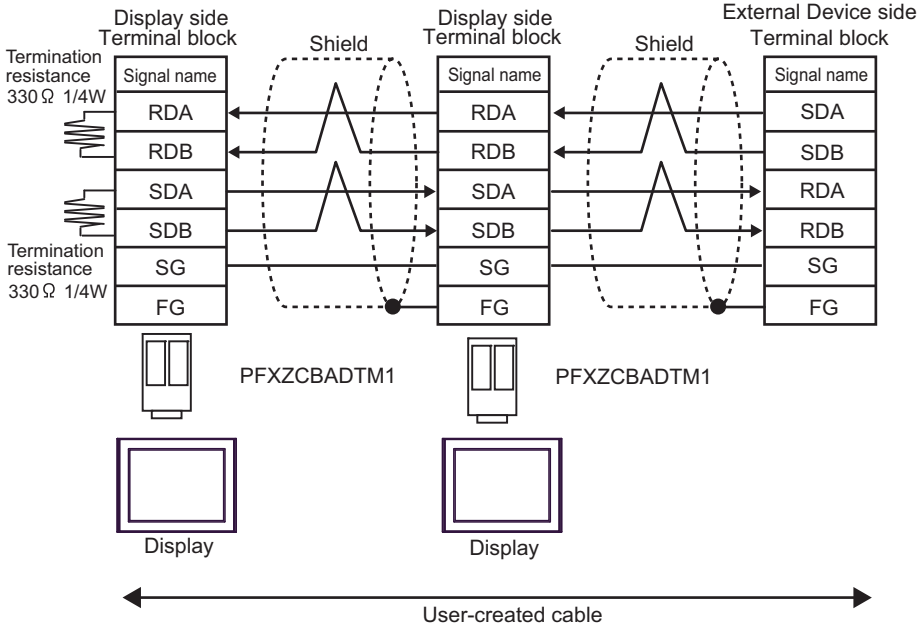

IMPORTANT

- The termination resistance of 330Ω/1/4W is required between SDA-SDB and RDA-RDB in the unit on the terminatory External Device.
- When the termination resistance is attached to the unit, you can turn ON the switch to load the termination resistance. Please refer to the manual of the External Device for more details.

4I)

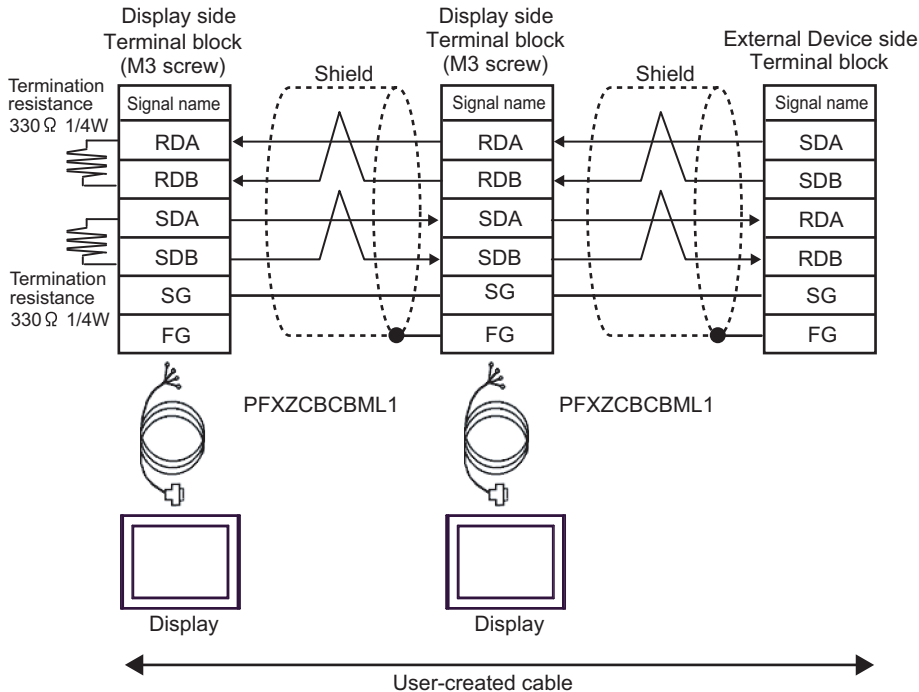

- IMPORTANT**
- The termination resistance of 330Ω1/4W is required between SDA-SDB and RDA-RDB in the unit on the terminatory External Device.
 - When the termination resistance is attached to the unit, you can turn ON the switch to load the termination resistance. Please refer to the manual of the External Device for more details.

4J)

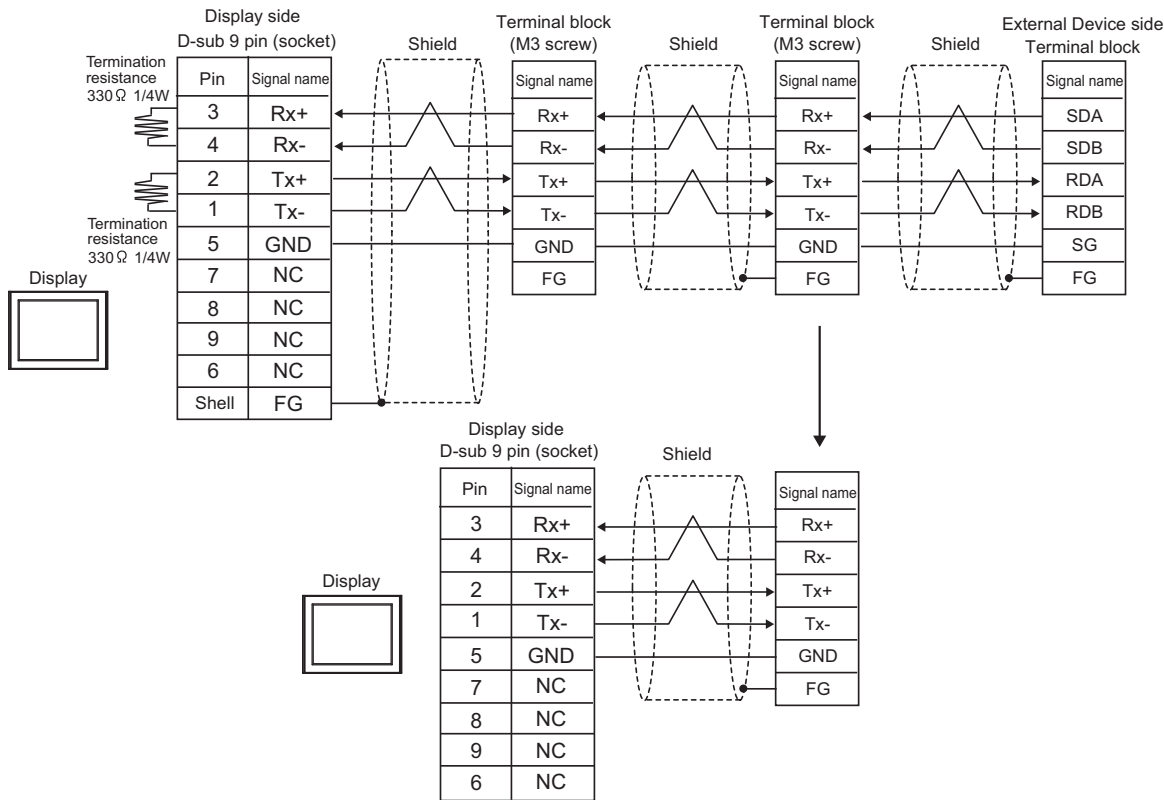

IMPORTANT

- The termination resistance of 330Ω/1/4W is required between SDA-SDB and RDA-RDB in the unit on the terminatory External Device.
- When the termination resistance is attached to the unit, you can turn ON the switch to load the termination resistance. Please refer to the manual of the External Device for more details.

6 Supported Device

Range of supported device address is shown in the table below. Please note that the actually supported range of the devices varies depending on the External Device to be used. Please check the actual range in the manual of your External Device.

6.1 MELSEC AnA Series, Q Series A Mode

 This address can be specified as system data area.

Device	Bit Address	Word Address	32bits	Notes
Input	X00000 - X01FFF (X007FF* ¹)	X00000 - X01FF0 (X007F0* ¹)	L/H	***0
Output	Y00000 - Y01FFF (Y007FF* ¹)	Y00000 - Y01FF0 (Y007F0* ¹)		***0
Internal Relay	M0000 - M8191	M0000 - M8176		+16
Latch Relay	L000000 - L008191	L000000 - L008176		+16
Step Relay	S000000 - S008191	S000000 - S008176		+16
Link Relay	B00000 - B01FFF (B00FFF* ¹)	B00000 - B01FF0 (B00FF0* ¹)		***0
Annunciator	F000000 - F002047	F000000 - F002032		+16
Special Relay* ²	M9000 - M9255	M9000 - M9240		+16
Timer (Contact)	TS00000 - TS02047	-----		
Timer (Coil)	TC00000 - TC02047	-----		
Counter (Contact)	CS00000 - CS01023	-----		
Counter (Coil)	CC00000 - CC01023	-----		
Timer (Current Value)	-----	TN00000 - TN02047		
Counter (Current Value)	-----	CN00000 - CN01023		
Data Register	-----	D00000 - D08191 (D06143* ¹)		B:15
Link Register	-----	W0000 - W1FFF (W0FFF* ¹)		B:F
File Register	-----	R00000 - R08191		B:15
Extension File Register	-----	0R0000 - 0R8191 : 64R0000 - 64R8191		B:15
Special Register* ²	-----	D09000 - D09255	B:15	

*1 Shows the maximum device number that can be specified in the computer link unit except AJ71UC24, A1SJ71UC24 - R2/R4/PRF.















- *2 Divided into 3 areas, for read only, for write only, for the system. When you write outside the write enable range, CPU error of the External Device may occur.

NOTE

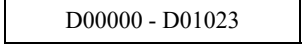
- Please refer to the GP-Pro EX Reference Manual for system data area.
Cf. GP-Pro EX Reference Manual "LS Area (Direct Access Method Area)"
- Please refer to the precautions on manual notation for icons in the table.
 "Manual Symbols and Terminology"

6.2 MELSEC AnN Series

 This address can be specified as system data area.

Device	Bit Address	Word Address	32bits	Notes
Input	X00000 - X007FF	X00000 - X007F0	L/H	
Output	Y00000 - Y007FF	Y00000 - Y007F0		
Internal Relay	M0000 - M2047	M0000 - M2032		
Latch Relay	L000000 - L002047	L000000 - L002032		
Step Relay	S000000 - S002047	S000000 - S002032		
Link Relay	B00000 - B003FF	B00000 - B003F0		
Annunciator	F000000 - F000255	F000000 - F000240		
Special Relay* ¹	M9000 - M9255	M9000 - M9240		
Timer (Contact)	TS00000 - TS00255	-----		
Timer (Coil)	TC00000 - TC00255	-----		
Counter (Contact)	CS00000 - CS00255	-----		
Counter (Coil)	CC00000 - CC00255	-----		
Timer (Current Value)	-----	TN00000 - TN00255		
Counter (Current Value)	-----	CN00000 - CN00255		
Data Register	-----	 D00000 - D01023		
Link Register	-----	W0000 - W03FF		
File Register	-----	R00000 - R08191		
Extension File Register	-----	0R0000 - 0R8191 : 28R0000 - 28R8191		
Special Register* ¹	-----	D09000 - D09255		











*1 Divided into 3 areas, for read only, for write only, for the system. When you write outside the write enable range, CPU error of the External Device may occur.

NOTE

- Please refer to the GP-Pro EX Reference Manual for system data area.
Cf. GP-Pro EX Reference Manual "LS Area (Direct Access Method Area)"
- Please refer to the precautions on manual notation for icons in the table.
 "Manual Symbols and Terminology"

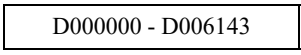
6.3 MELSEC QnA Series

 This address can be specified as system data area.

Device	Bit Address	Word Address	32bits	Notes
Input Relay	X0000 - X07FF	X0000 - X07F0	[L/H]	
Output Relay	Y0000 - Y07FF	Y0000 - Y07F0		
Internal Relay	M0000 - M8191	M0000 - M8176		
Special Relay	M9000 - M9255 (SM1000 - SM1255)	M9000 - M9240 (SM1000 - SM1240)		
Annunciator	F00000 - F02047	F00000 - F02047		
Link Relay	B00000 - B00FFF	B00000 - B00FF0		
Timer (Contact)	TS00000 - TS02047	-----		
Timer (Coil)	TC00000 - TC02047	-----		
Counter (Contact)	CS00000 - CS01023	-----		
Counter (Coil)	CC00000 - CC01023	-----		
Timer (Current Value)	-----	TN00000 - TN02047		
Counter (Current Value)	-----	CN00000 - CN01023		
Data Register	-----	 D000000 - D006143		
Special Register	-----	D009000 - D009255 (SD1000 - SD1255)		
Link Register	-----	W0000 - W0FFF		

NOTE

- Please refer to the GP-Pro EX Reference Manual for system data area.
Cf. GP-Pro EX Reference Manual "LS Area (Direct Access Method Area)"
- Please refer to the precautions on manual notation for icons in the table.

 "Manual Symbols and Terminology"

7 Device Code and Address Code

Use device code and address code when you select "Device Type & Address" for the address type in data displays.

Device	Device Name	Device Code (HEX)	Address Code
Input	X	0080	Value of word address divided by 0x10
Output	Y	0081	Value of word address divided by 0x10
Internal Relay	M (0000 - 8991)	0082	Value of word address divided by 16
Special Relay	M (9000 - 9991)	0083	Value of (word address - 9000) divided by 16
Latch Relay	L	0084	Value of word address divided by 16
Step Relay	S	0087	Value of word address divided by 16
Link Relay	B	0088	Value of word address divided by 0x10
Annunciator	F	0085	Value of word address divided by 16
Timer (Current Value)	TN	0060	Word Address
Counter (Current Value)	CN	0061	Word Address
Data Register Special Register	D	0000	Word Address
Link Register	W	0002	Word Address
File Register	R	000F	Word Address
Extension File Register	0R	0010	Word Address
	:	:	:
	31R	002F	Word Address
	:	:	:
	64R	0050	Word Address

8 Error Messages

Error messages are displayed on the Display screen as follows: "No.: Device Name: Error Message (Error Occurrence Area)". Each description is shown below.

Item	Description
No.	Error No.
Device Name	Name of the External Device where error occurs. Device name is a title of the External Device set with GP-Pro EX. (Initial value [PLC1])
Error Message	Displays messages related to the error which occurs.
Error Occurrence Area	<p>Displays IP address or device address of the External Device where error occurs, or error codes received from the External Device.</p> <p>NOTE</p> <ul style="list-style-type: none"> • IP address is displayed such as "IP address(Decimal): MAC address(Hex)". • Device address is displayed such as "Address: Device address". • Received error codes are displayed such as "Decimal[Hex]".

Display Examples of Error Messages

"RHAA035: PLC1: Error has been responded for device write command (Error Code: 2 [02H])"

NOTE

- Refer to your External Device manual for details on received error codes.
- Refer to "Display-related errors" in "Maintenance/Troubleshooting Guide" for details on the error messages common to the driver.