



S10 Series SIO Driver

1	System Configuration.....	3
2	Selection of External Device	7
3	Example of Communication Setting.....	8
4	Setup Items.....	18
5	Cable Diagram	23
6	Supported Device.....	36
7	Device Code and Address Code.....	45
8	Error Messages.....	54

Introduction

This manual describes how to connect the Display and the External Device (target PLC).

In this manual, the connection procedure will be described by following the below sections:

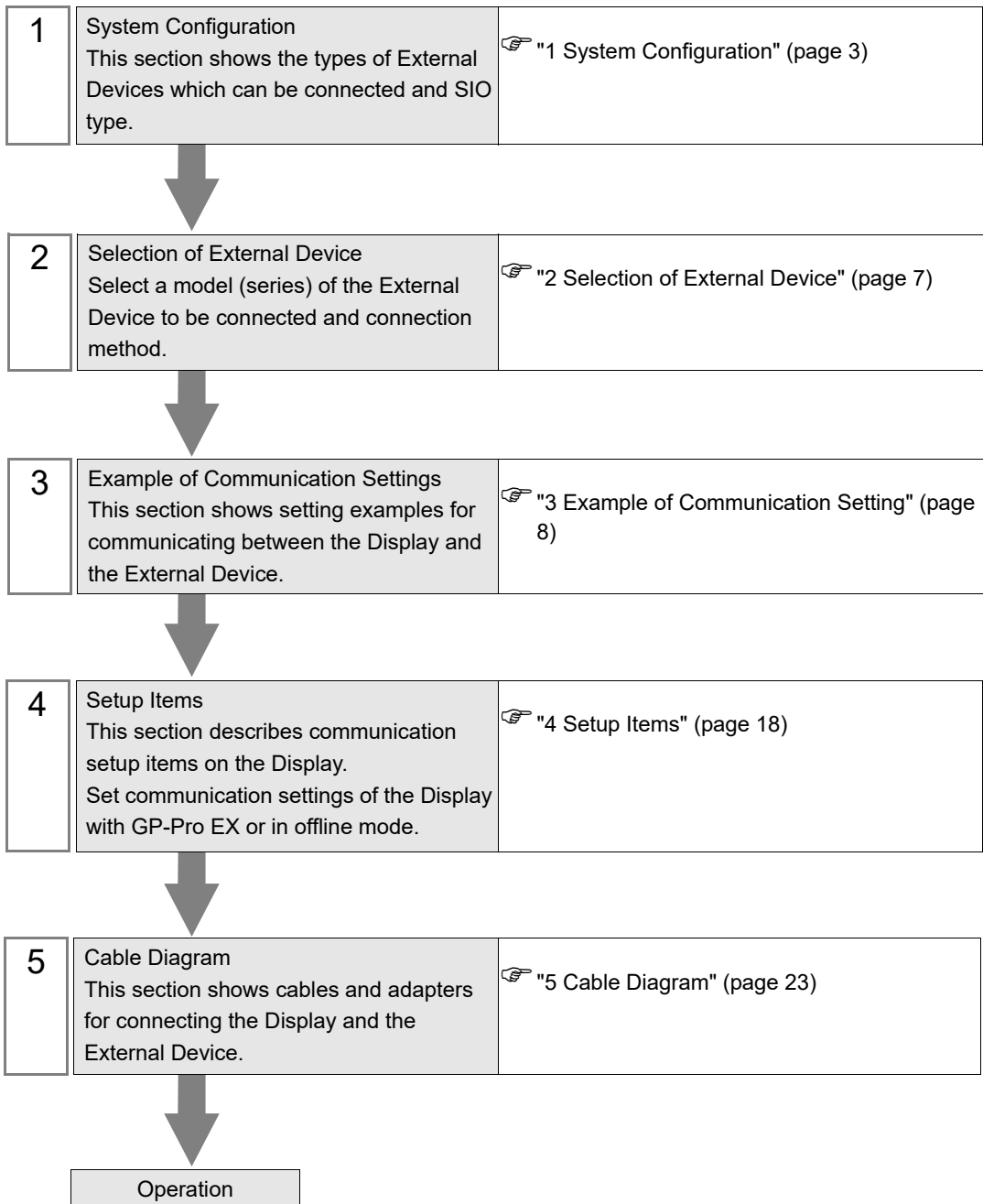

1 System Configuration

The system configuration in the case when the External Device of Hitachi, Ltd. and the Display are connected is shown.

Series	CPU	Link I/F	SIO Type	Setting Example	Cable Diagram
S10V	LQP510*1	UP LINK Connector on LPU Module	RS422/485 (4wire)	Setting Example 1 (page 8)	Cable Diagram 1 (page 23)
		LQE560 (CN1)	RS232C	Setting Example 2 (page 9)	Cable Diagram 2 (page 29)
		LQE560 (CN2)	RS232C	Setting Example 3 (page 10)	Cable Diagram 2 (page 29)
		LQE565 (CN1)	RS422/485 (4wire)	Setting Example 4 (page 11)	Cable Diagram 1 (page 23)
		LQE565 (CN2)	RS422/485 (4wire)	Setting Example 5 (page 12)	Cable Diagram 1 (page 23)
HIDIC-S10α	2α (LWP000) *2, 2αE (LWP040) *2, 2αH (LWP070) *2	Terminal Block on CPU Unit	RS422/485 (4wire)	Setting Example 6 (page 13)	Cable Diagram 3 (page 31)
	4α, 4αF	LWE805			
S10mini	Model S (LQP000), Model H (LQP010), Model F (LQP011), Model D (LQP120), Model L (LQP800)	LQE060 (CN1) LQE160 (CN1) LQE560 (CN1)	RS232C	Setting Example 7 (page 14)	Cable Diagram 2 (page 29)
		LQE060 (CN2) LQE160 (CN2) LQE560 (CN2)	RS232C	Setting Example 8 (page 15)	
		LQE165 (CN1) LQE565 (CN1)	RS422/485 (4wire)	Setting Example 9 (page 16)	Cable Diagram 1 (page 23)
		LQE165 (CN2) LQE565 (CN2)	RS422/485 (4wire)	Setting Example 10 (page 17)	

*1 To connect to the Display, a C revision or higher version of the LPU Module is required. Check the alphabet on the right end of the bar code seal (top surface of the LPU Module) for the revision number of the LPU Module.

*2 Connect to the CPU Module's HOST LINK COMPUTER LINK Input/Output Terminal (Upper Calculation I/F).

■ Connection Configuration

- 1:1 connection

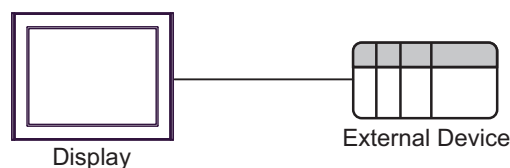

■ IPC COM Port

When connecting IPC with an External Device, the COM port used depends on the series and SIO type. Please refer to the IPC manual for details.

Usable port

Series	Usable Port		
	RS-232C	RS-422/485(4 wire)	RS-422/485(2 wire)
PS-2000B	COM1 ^{*1} , COM2, COM3 ^{*1} , COM4	-	-
PS-3450A, PS-3451A, PS3000-BA, PS3001-BD	COM1, COM2 ^{*1*2}	COM2 ^{*1*2}	COM2 ^{*1*2}
PS-3650A (T41 model), PS-3651A (T41 model)	COM1 ^{*1}	-	-
PS-3650A (T42 model), PS-3651A (T42 model)	COM1 ^{*1*2} , COM2	COM1 ^{*1*2}	COM1 ^{*1*2}
PS-3700A (Pentium®4-M) PS-3710A	COM1 ^{*1} , COM2 ^{*1} , COM3 ^{*2} , COM4	COM3 ^{*2}	COM3 ^{*2}
PS-3711A	COM1 ^{*1} , COM2 ^{*2}	COM2 ^{*2}	COM2 ^{*2}
PS4000 ^{*3}	COM1, COM2	-	-
PL3000	COM1 ^{*1*2} , COM2 ^{*1} , COM3, COM4	COM1 ^{*1*2}	COM1 ^{*1*2}
PE-4000B Atom N270	COM1, COM2	-	-
PE-4000B Atom N2600	COM1, COM2	COM3 ^{*4} , COM4 ^{*4} , COM5 ^{*4} , COM6 ^{*4}	COM3 ^{*4} , COM4 ^{*4} , COM5 ^{*4} , COM6 ^{*4}
PS5000 (Slim Panel Type Core i3 Model) ^{*5*6}	COM1, COM2 ^{*4}	COM2 ^{*4}	COM2 ^{*4}
PS5000 (Slim Panel Type Atom Model) ^{*5*6}	COM1, COM2 ^{*7}	COM2 ^{*7}	COM2 ^{*7}
PS5000 (Enclosed Panel Type) ^{*8}	COM1	-	-
PS5000 (Modular Type PFXPU/PFXPP) ^{*5*6} PS5000 (Modular Type PFXPL2B5-6)	COM1 ^{*7}	COM1 ^{*7}	COM1 ^{*7}
PS5000 (Modular Type PFXPL2B1-4)	COM1, COM2 ^{*7}	COM2 ^{*7}	COM2 ^{*7}
PS6000 (Advanced Box) PS6000 (Standard Box)	COM1 ^{*9}	*10	*10
PS6000 (Basic Box)	COM1 ^{*9}	COM1 ^{*9}	COM1 ^{*9}

*1 The RI/5V can be switched. Use the IPC's switch to change if necessary.

*2 Set up the SIO type with the DIP Switch. Please set up as follows according to SIO type to be used.

- *3 When making communication between an External Device and COM port on the Expansion slot, only RS-232C is supported. However, ER (DTR/CTS) control cannot be executed because of the specification of COM port.
For connection with External Device, use user-created cables and disable Pin Nos. 1, 4, 6 and 9. Please refer to the IPC manual for details of pin layout.
- *4 Set up the SIO type with the BIOS. Please refer to the IPC manual for details of BIOS.
- *5 When setting up communication between an External Device and the RS-232C/422/485 interface module, use the IPC (RS-232C) or PS5000 (RS-422/485) cable diagrams. However, when using PFXZPBMPR42P2 in a RS-422/485 (4-wire) configuration with no flow control, connect 7.RTS+ and 8.CTS+, and connect 6.RTS- and 9.CTS-.
When using RS-422/485 communication with External Devices, you may need to reduce the transmission speed and increase the TX Wait time.
- *6 To use RS-422/485 communication on the RS-232C/422/485 interface module, the DIP Switch setting is required. Please refer to "Knowledge Base" (FAQs) on the support site. (<http://www.pro-face.com/trans/en/manual/1001.html>)

Settings	FAQ ID
PFXZPBMPR42P2, RS422/485 change method	FA263858
PFXZPBMPR42P2 termination resistor setting	FA263974
PFXZPBMPR44P2, RS422/485 change method	FA264087
PFXZPBMPR44P2 termination resistor setting	FA264088

- *7 Set up the SIO type with the DIP Switch. Please refer to the IPC manual for details of DIP Switch. The BOX Atom has not a switch to set the RS-232C, RS-422/485 mode. Use the BIOS for the setting.
- *8 For the connection with the External Device, on the user-created cable read as if the connector on the Display-side is a M12 A-coding 8 pin socket. The pin assignment is the same as described in the cable diagram. For the M12 A-coding connector, use PFXZPSCNM122.
- *9 In addition to COM1, you can also use the COM port on the optional interface.
- *10 Install the optional interface in the expansion slot.

DIP Switch settings (PL3000 / PS3000 Series)

RS-232C

DIP Switch	Setting	Description
1	OFF*1	Reserved (always OFF)
2	OFF	SIO type: RS-232C
3	OFF	
4	OFF	Output mode of SD (TXD) data: Always output
5	OFF	Terminal resistance (220Ω) insertion to SD (TXD): None
6	OFF	Terminal resistance (220Ω) insertion to RD (RXD): None
7	OFF	Short-circuit of SDA (TXA) and RDA (RXA): Not available
8	OFF	Short-circuit of SDB (TXB) and RDB (RXB): Not available
9	OFF	RS (RTS) Auto control mode: Disabled
10	OFF	

*1 When using PS-3450A, PS-3451A, PS3000-BA and PS3001-BD, turn ON the set value.

RS-422/485 (4 wire)

DIP Switch	Setting	Description
1	OFF	Reserved (always OFF)
2	ON	SIO type: RS-422/485
3	ON	
4	OFF	Output mode of SD (TXD) data: Always output
5	OFF	Terminal resistance (220Ω) insertion to SD (TXD): None
6	OFF	Terminal resistance (220Ω) insertion to RD (RXD): None
7	OFF	Short-circuit of SDA (TXA) and RDA (RXA): Not available
8	OFF	Short-circuit of SDB (TXB) and RDB (RXB): Not available
9	OFF	RS (RTS) Auto control mode: Disabled
10	OFF	

RS-422/485 (2 wire)

DIP Switch	Setting	Description
1	OFF	Reserved (always OFF)
2	ON	SIO type: RS-422/485
3	ON	
4	OFF	Output mode of SD (TXD) data: Always output
5	OFF	Terminal resistance (220Ω) insertion to SD (TXD): None
6	OFF	Terminal resistance (220Ω) insertion to RD (RXD): None
7	ON	Short-circuit of SDA (TXA) and RDA (RXA): Available
8	ON	Short-circuit of SDB (TXB) and RDB (RXB): Available
9	ON	RS (RTS) Auto control mode: Enabled
10	ON	

2 Selection of External Device

Select the External Device to be connected to the Display.

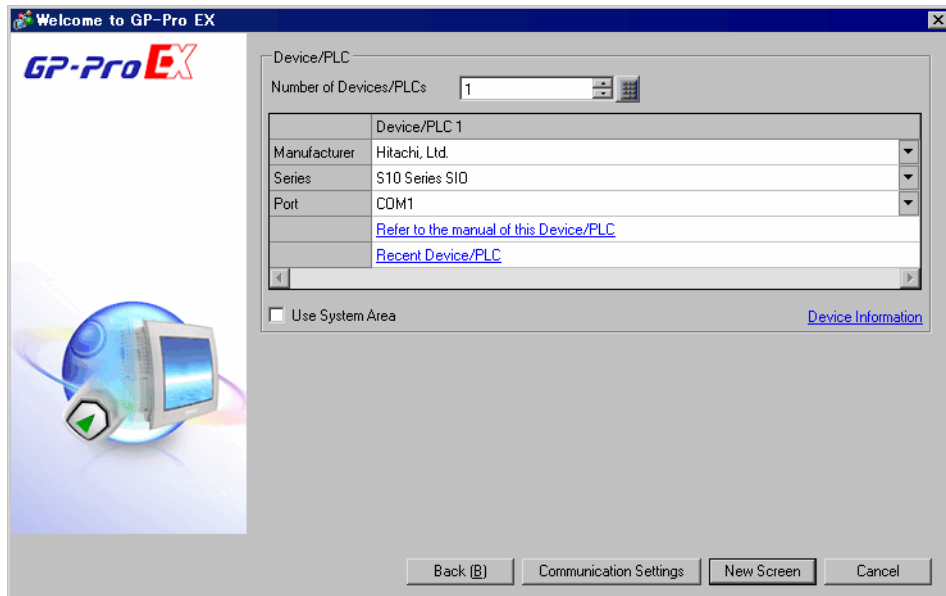

Setup Items	Setup Description
Number of Devices/PLCs	Enter an integer from 1 to 4 to define the number of Devices/PLCs to connect to the display.
Manufacturer	Select the manufacturer of the External Device to connect. Select "Hitachi, Ltd.".
Series	Select the External Device model (series) and the connection method. Select "S10 Series SIO". In System configuration, make sure the External Device you are connecting is supported by "S10 Series SIO". ☞ "1 System Configuration" (page 3)
Port	Select the Display port to be connected to the External Device.
Use System Area	Check this option to synchronize the system data area of the Display and the device (memory) of the External Device. When synchronized, you can use the External Device's ladder program to switch the display or display the window on the Display. Cf. GP-Pro EX Reference Manual "LS Area (Direct Access Method Area)" This feature can also be set in GP-Pro EX or in the Display's offline mode. Cf. GP-Pro EX Reference Manual "System Settings [Display Unit] - [System Area] Settings Guide" Cf. Maintenance/Troubleshooting Guide "Main Unit - System Area Settings"

3 Example of Communication Setting

The following shows examples of communication settings of the Display and the External Device, which is recommended by Pro-face.

3.1 Setting Example 1

■ Settings of GP-Pro EX

◆ Communication Settings

To display the setup screen, from the [Project] menu, point to [System Settings] and select [Device/PLC].

The screenshot shows the 'Device/PLC 1' configuration window. It is divided into several sections:

- Summary:** Manufacturer: Hitachi, Ltd.; Series: S10 Series SIO; Port: COM1; Text Data Mode: 1.
- Communication Settings:**
 - SIO Type: RS232C, RS422/485(2wire), RS422/485(4wire)
 - Speed: 19200
 - Data Length: 7, 8
 - Parity: NONE, EVEN, ODD
 - Stop Bit: 1, 2
 - Flow Control: NONE, ER(DTR/CTS), XON/XOFF
 - Timeout: 3 (sec)
 - Retry: 2
 - Wait To Send: 0 (ms)
- RI / VCC:** RI, VCC. A note states: "In the case of RS232C, you can select the 9th pin to RI (Input or VCC (5V Power Supply)). If you use the Digital's RS232C Isolation Unit, please select it to VCC."
- Device-Specific Settings:** Allowable Number of Devices/PLCs: 1. A table lists the device: No. 1, Device Name: PLC1, Settings: Series=S10V.

◆ Device Setting

To display the [Individual Device Settings] dialog box, from [Device-Specific Settings] in the [Device/PLC] window, select the external device and click [Settings] .

The screenshot shows the 'Individual Device Settings' dialog box for 'PLC1'. It contains the following information:

- Series: S10V, HIDIC-S10alpha/S10mini
- Expanded Memory Address(Hex): 00000000
- Buttons: Default, OK, Cancel.

■ Settings of External Device

Communication setting of External Device is fixed. No setting is required.

3.2 Setting Example 2

■ Settings of GP-Pro EX

◆ Communication Settings

To display the setup screen, from the [Project] menu, point to [System Settings] and select [Device/PLC].

◆ Device Setting

To display the [Individual Device Settings] dialog box, from [Device-Specific Settings] in the [Device/PLC] window, select the external device and click [Settings] .

■ Settings of External Device

Communication setting of External Device is fixed. No setting is required.

Rotary switch of External Device needs to be set depending on the channel in use.

Set as shown in the table below.

Channel in use	Rotary Switch
	CN1MODU
CN1	8

3.3 Setting Example 3

■ Settings of GP-Pro EX

◆ Communication Settings

To display the setup screen, from the [Project] menu, point to [System Settings] and select [Device/PLC].

◆ Device Setting

To display the [Individual Device Settings] dialog box, from [Device-Specific Settings] in the [Device/PLC] window, select the external device and click [Settings] .

■ Settings of External Device

Communication setting of External Device is fixed. No setting is required.

Rotary switch of External Device needs to be set depending on the channel in use.

Set as shown in the table below.

Channel in use	Rotary Switch
	CN2MODU
CN2	9

3.4 Setting Example 4

■ Settings of GP-Pro EX

◆ Communication Settings

To display the setup screen, from the [Project] menu, point to [System Settings] and select [Device/PLC].

Device/PLC 1

Summary [Change Device/PLC](#)

Manufacturer: Hitachi, Ltd. Series: S10 Series SIO Port: COM1

Text Data Mode: 1 [Change](#)

Communication Settings

SIO Type: RS232C RS422/485(2wire) RS422/485(4wire)

Speed: 19200

Data Length: 7 8

Parity: NONE EVEN ODD

Stop Bit: 1 2

Flow Control: NONE ER(DTR/CTS) XON/XOFF

Timeout: 3 (sec)

Retry: 2

Wait To Send: 0 (ms)

RI / VCC RI VCC

In the case of RS232C, you can select the 9th pin to RI (Input) or VCC (5V Power Supply). If you use the Digital's RS232C Isolation Unit, please select it to VCC.

Default

Device-Specific Settings

Allowable Number of Devices/PLCs: 1 [Add Device](#)

No.	Device Name	Settings
1	PLC1	Series=S10V

[Add Indirect Device](#)

◆ Device Setting

To display the [Individual Device Settings] dialog box, from [Device-Specific Settings] in the [Device/PLC] window, select the external device and click [Settings] .

Individual Device Settings

PLC1

Series: S10V HIDIC-S10alpha/S10mini

Please reconfirm all of address settings that you are using if you have changed the series.

Expanded Memory Address(Hex): 00000000

Default

OK Cancel

■ Settings of External Device

Communication setting of External Device is fixed. No setting is required.

Rotary switch of External Device needs to be set depending on the channel in use.

Set as shown in the table below.

Channel in use	Rotary Switch
	CN1MODU
CN1	8

3.5 Setting Example 5

■ Settings of GP-Pro EX

◆ Communication Settings

To display the setup screen, from the [Project] menu, point to [System Settings] and select [Device/PLC].

◆ Device Setting

To display the [Individual Device Settings] dialog box, from [Device-Specific Settings] in the [Device/PLC] window, select the external device and click [Settings] .

■ Settings of External Device

Communication setting of External Device is fixed. No setting is required.

Rotary switch of External Device needs to be set depending on the channel in use.

Set as shown in the table below.

Channel in use	Rotary Switch
	CN2MODU
CN2	9

3.6 Setting Example 6

■ Settings of GP-Pro EX

◆ Communication Settings

To display the setup screen, from the [Project] menu, point to [System Settings] and select [Device/PLC].

◆ Device Setting

To display the [Individual Device Settings] dialog box, from [Device-Specific Settings] in the [Device/PLC] window, select the external device and click [Settings] .

■ Settings of External Device

Communication setting of External Device is fixed. No setting is required.

Communication speed differs depending on the External Device in use.

Please refer to the manual of the External Device for more details.

3.7 Setting Example 7

■ Settings of GP-Pro EX

◆ Communication Settings

To display the setup screen, from the [Project] menu, point to [System Settings] and select [Device/PLC].

◆ Device Setting

To display the [Individual Device Settings] dialog box, from [Device-Specific Settings] in the [Device/PLC] window, select the external device and click [Settings] .

■ Settings of External Device

Communication setting of External Device is fixed. No setting is required.

Rotary switch of External Device needs to be set depending on the channel in use.

Set as shown in the table below.

Channel in use	Rotary Switch
	CN1MODU
CN1	8

3.8 Setting Example 8

■ Settings of GP-Pro EX

◆ Communication Settings

To display the setup screen, from the [Project] menu, point to [System Settings] and select [Device/PLC].

◆ Device Setting

To display the [Individual Device Settings] dialog box, from [Device-Specific Settings] in the [Device/PLC] window, select the external device and click [Settings] .

■ Settings of External Device

Communication setting of External Device is fixed. No setting is required.

Rotary switch of External Device needs to be set depending on the channel in use.

Set as shown in the table below.

Channel in use	Rotary Switch
	CN2MODU
CN2	9

3.9 Setting Example 9

■ Settings of GP-Pro EX

◆ Communication Settings

To display the setup screen, from the [Project] menu, point to [System Settings] and select [Device/PLC].

Device/PLC 1

Summary [Change Device/PLC](#)

Manufacturer: Hitachi, Ltd. Series: S10 Series SIO Port: COM1

Text Data Mode: 1 [Change](#)

Communication Settings

SIO Type: RS232C RS422/485(2wire) RS422/485(4wire)

Speed: 19200

Data Length: 7 8

Parity: NONE EVEN ODD

Stop Bit: 1 2

Flow Control: NONE ER(DTR/CTS) XON/XOFF

Timeout: 3 (sec)

Retry: 2

Wait To Send: 0 (ms)

RI / VCC RI VCC

In the case of RS232C, you can select the 9th pin to RI (Input) or VCC (5V Power Supply). If you use the Digital's RS232C Isolation Unit, please select it to VCC.

Default

Device-Specific Settings

Allowable Number of Devices/PLCs: 1 [Add Device](#)

No.	Device Name	Settings	Add Indirect Device
1	PLC1	Series=HIDIC-S10alpha/S10mini, Expanded Memory A	+

◆ Device Setting

To display the [Individual Device Settings] dialog box, from [Device-Specific Settings] in the [Device/PLC] window, select the external device and click [Settings] .

Individual Device Settings

PLC1

Series: S10V HIDIC-S10alpha/S10mini

Please reconfirm all of address settings that you are using if you have changed the series.

Expanded Memory Address(Hex): 00000000

Default

OK Cancel

■ Settings of External Device

Communication setting of External Device is fixed. No setting is required.

Rotary switch of External Device needs to be set depending on the channel in use.

Set as shown in the table below.

Channel in use	Rotary Switch
	CN1MODU
CN1	8

3.10 Setting Example 10

■ Settings of GP-Pro EX

◆ Communication Settings

To display the setup screen, from the [Project] menu, point to [System Settings] and select [Device/PLC].

Device/PLC 1

Summary [Change Device/PLC](#)

Manufacturer Series Port

Text Data Mode [Change](#)

Communication Settings

SIO Type RS232C RS422/485(2wire) RS422/485(4wire)

Speed

Data Length 7 8

Parity NONE EVEN ODD

Stop Bit 1 2

Flow Control NONE ER(DTR/CTS) XON/XOFF

Timeout (sec)

Retry

Wait To Send (ms)

RI / VCC RI VCC

In the case of RS232C, you can select the 9th pin to RI (Input) or VCC (5V Power Supply). If you use the Digital's RS232C Isolation Unit, please select it to VCC.

Device-Specific Settings

Allowable Number of Devices/PLCs [Add Device](#)

No.	Device Name	Settings
<input type="button" value="1"/>	<input type="text" value="PLC1"/>	<input type="text" value="Series=HIDIC-S10alpha/S10mini,Expanded Memory A"/>

[Add Indirect Device](#)

◆ Device Setting

To display the [Individual Device Settings] dialog box, from [Device-Specific Settings] in the [Device/PLC] window, select the external device and click [Settings] .

Individual Device Settings

PLC1

Series S10V HIDIC-S10alpha/S10mini

Please reconfirm all of address settings that you are using if you have changed the series.

Expanded Memory Address(Hex)

■ Settings of External Device

Communication setting of External Device is fixed. No setting is required.

Rotary switch of External Device needs to be set depending on the channel in use.

Set as shown in the table below.

Channel in use	Rotary Switch
	CN2MODU
CN2	9

4 Setup Items

Set communication settings of the Display with GP-Pro Ex or in offline mode of the Display.

The setting of each parameter must be identical to that of the External Device.

 "3 Example of Communication Setting" (page 8)

4.1 Setup Items in GP-Pro EX

■ Communication Settings

To display the setup screen, from the [Project] menu, point to [System Settings] and select [Device/PLC].

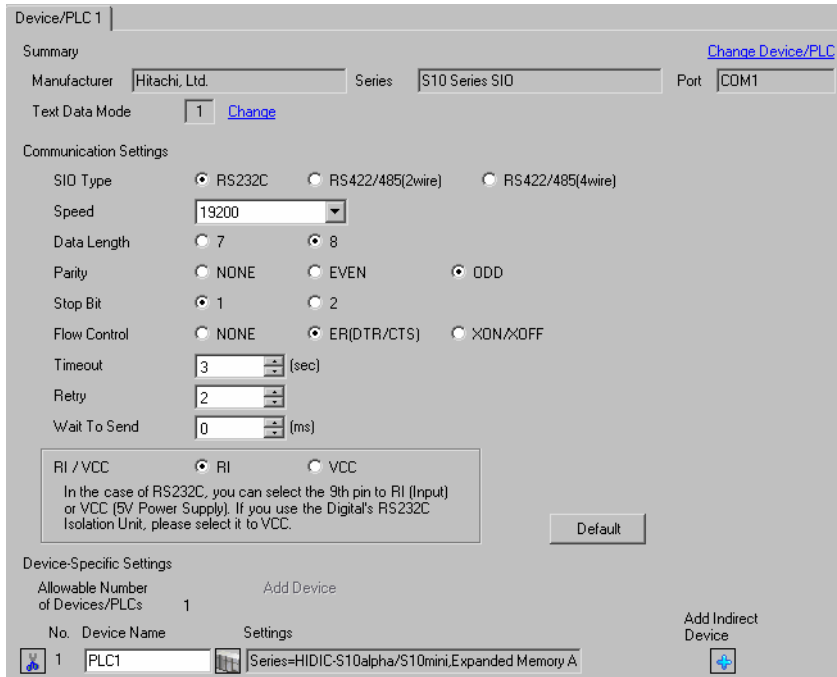

Device/PLC 1

Summary [Change Device/PLC](#)

Manufacturer Series Port

Text Data Mode [Change](#)

Communication Settings

SIO Type RS232C RS422/485(2wire) RS422/485(4wire)

Speed

Data Length 7 8

Parity NONE EVEN ODD

Stop Bit 1 2

Flow Control NONE ER(DTR/CTS) XON/XOFF

Timeout (sec)

Retry

Wait To Send (ms)

RI / VCC RI VCC

In the case of RS232C, you can select the 9th pin to RI (Input) or VCC (5V Power Supply). If you use the Digital's RS232C Isolation Unit, please select it to VCC.

Device-Specific Settings

Allowable Number of Devices/PLCs [Add Device](#)

No.	Device Name	Settings
<input type="button" value="1"/>	<input type="text" value="PLC1"/>	<input type="button" value="Settings"/> Series=HIDIC-S10alpha/S10mini,Expanded Memory A

[Add Indirect Device](#)

Setup Items	Setup Description
SIO Type	Select the SIO type to communicate with the External Device.
Speed	Select the communication speed between the External Device and the Display.
Data Length	Select data length.
Parity	Select how to check parity.
Stop Bit	Select stop bit length.
Flow Control	Select the communication control method to prevent overflow of transmission and reception data.
Timeout	Use an integer from 1 to 127 to enter the time (s) for which the Display waits for the response from the External Device.
Retry	In case of no response from the External Device, use an integer from "0 to 255" to enter how many times the Display retransmits the command.
Wait To Send	Use an integer from "0 to 255" to enter standby time (ms) for the Display from receiving packets to transmitting next commands.

Continues to the next page.

Setup Items	Setup Description
RI/VCC	You can switch RI/VCC of the 9th pin when you select RS232C for SIO type. When you connect to IPC, you need to use the IPC change switch to change RI/5V. Please refer to the manual of IPC for details.

NOTE

- Refer to the GP-Pro EX Reference Manual for Indirect Device.

Cf. GP-Pro EX Reference Manual "Changing the Device/PLC at Runtime (Indirect Device)"

■ Device Setting

To display the [Individual Device Settings] dialog box, from [Device-Specific Settings] in the [Device/PLC] window, select the external device and click [Settings] .

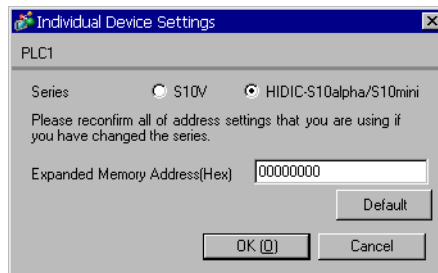

Setup Items	Setup Description
Series	Select the series of the External Device.
Expanded Memory Address (HEX)	Enter the address of the expanded memory with "00000000 to FFFFFFFF" (HEX).

4.2 Settings in Offline Mode

NOTE

- Refer to the Maintenance/Troubleshooting guide for information on how to enter offline mode or about the operation.

Cf. Maintenance/Troubleshooting Guide "Offline Mode"

- The number of the setup items to be displayed for 1 page in the off-line mode depends on the Display in use. Please refer to the Reference manual for details.

■ Communication Settings

To display the setting screen, touch [Device/PLC Settings] from [Peripheral Equipment Settings] in the offline mode. Touch the External Device you want to set from the displayed list.

Comm.	Device	Option		
S10 Series SIO [COM1] Page 1/1				
SIO Type	RS232C			
Speed	19200			
Data Length	<input type="radio"/> 7 <input checked="" type="radio"/> 8			
Parity	<input type="radio"/> NONE <input type="radio"/> EVEN <input checked="" type="radio"/> ODD			
Stop Bit	<input checked="" type="radio"/> 1 <input type="radio"/> 2			
Flow Control	ER(DTR/CTS)			
Timeout(s)	3			
Retry	2			
Wait To Send(ms)	0			
Exit		Back		2007/09/21 22:31:23

Setup Items	Setup Description
SIO Type	Select the SIO type to communicate with the External Device. IMPORTANT In the communication setting, confirm the serial interface specifications of the Display and set [SIO Type] correctly. If you select the SIO type the serial interface does not support, we cannot guarantee the operation. Please refer to the manual of the Display for more detail on the serial interface specifications.
Speed	Select the communication speed between the External Device and the Display.
Data Length	Select data length.
Parity	Select how to check parity.
Stop Bit	Select stop bit length.
Flow Control	Select the communication control method to prevent overflow of transmission and reception data.

Continues to the next page.

Setup Items	Setup Description
Timeout (s)	Use an integer from 1 to 127 to enter the time (s) for which the Display waits for the response from the External Device.
Retry	In case of no response from the External Device, use an integer from "0 to 255" to enter how many times the Display retransmits the command.
Wait To Send (ms)	Use an integer from "0 to 255" to enter standby time (ms) for the Display from receiving packets to transmitting next commands.

■ Device Setting

To display the setting screen, touch [Device/PLC Settings] from [Peripheral Equipment Settings]. Touch the External Device you want to set from the displayed list, and touch [Device Settings].

Comm.	Device	Option		
S10 Series SIO			[COM1]	Page 1/1
Device/PLC Name <input type="text" value="PLC1"/>				
Series		S10V		
Expanded Memory Address(HEX)		<input type="text" value="0"/>		
Exit		Back		2007/09/21 22:31:29

Setup Items	Setup Description
Device/PLC Name	Select the External Device to set. Device name is a title of the External Device set with GP-Pro EX. (Initial value [PLC1])
Series	Display the series of the External Device.
Expanded Memory Address (HEX)	Enter the address of the expanded memory with "00000000 to FFFFFFFF" (HEX).

■ Option

To display the setting screen, touch [Device/PLC Settings] from [Peripheral Equipment Settings]. Touch the External Device you want to set from the displayed list, and touch [Option].

Comm.	Device	Option		
S10 Series S10			[COM1]	Page 1/1
RI / VCC <input checked="" type="radio"/> RI <input type="radio"/> VCC In the case of RS232C, you can select the 9th pin to RI(Input) or VCC(5V Power Supply). If you use the Digital's RS232C Isolation Unit, please select it to VCC.				
	Exit		Back	2007/09/21 22:31:36

Setup Items	Setup Description
RI/VCC	You can switch RI/VCC of the 9th pin when you select RS232C for SIO type. When you connect to IPC, you need to use the IPC change switch to change RI/5V. Please refer to the manual of IPC for details.

NOTE

- GP-4100 series, GP-4*01TM and GP-Rear Module do not have the [Option] setting in the offline mode.

5 Cable Diagram

The cable diagram shown below may be different from the cable diagram recommended by Hitachi, Ltd..

Please be assured there is no operational problem in applying the cable diagram shown in this manual.

- The FG pin of the main body of the External Device must be D-class grounded. Please refer to the manual of the External Device for more details.
- SG and FG are connected inside the Display. When connecting SG to the External Device, design the system not to form short-circuit loop.
- If the communication is not stable due to the noise or other factors, connect the isolation unit.

Cable Diagram 1

Display (Connection Port)	Cable		Remarks
GP3000 ^{*1} (COM1) AGP-3302B (COM2) GP-4*01TM (COM1) GP-Rear Module (COM1) ST3000 ^{*2} (COM2) LT3000 (COM1) IPC ^{*3}	1A	COM port conversion adapter by Pro-face CA3-ADPCOM-01 + Connector terminal block conversion adapter by Pro-face CA3-ADPTRM-01 + Your own cable	Cable length: 500m or less
	1B	Your own cable	
GP3000 ^{*4} (COM2)	1C	Online adapter by Pro-face CA4-ADPONL-01 + Connector terminal block conversion adapter by Pro-face CA3-ADPTRM-01 + Your own cable	Cable length: 500m or less
	1D	Online adapter by Pro-face CA4-ADPONL-01 + Your own cable	
GP-4116T (COM1)	1G	Your own cable	Cable length: 500m or less
GP4000 ^{*5} (COM2) GP-4201T (COM1) SP5000 ^{*6} (COM1/2) SP-5B00 (COM2) ST6000 ^{*7} (COM2) ST-6200 (COM1) STM6000 (COM1) STC6000 (COM1) PS6000 (Basic Box) (COM1/2)	1E	RS-422 Terminal Block Conversion Adapter by Pro-face PFXZCBADTM1 ^{*8} + Your own cable	Cable length: 500m or less
	1B	Your own cable	
PE-4000B ^{*9} PS5000 ^{*9} PS6000 (Optional Interface) ^{*9}	1F	Your own cable	Cable length: 500m or less

- *1 All GP models except AGP-3302B
- *2 Except AST-3211A and AST-3302B
- *3 Available to use only the COM ports which can communicate in RS422/485(4 wire). (Except PE-4000B, PS5000, and PS6000)
☞ "■ IPC COM Port" (page 4)
- *4 All GP models except GP-3200 Series and AGP-3302B
- *5 All GP4000 models except GP-4100 Series, GP-4*01TM, GP-Rear Module, GP-4201T and GP-4*03T
- *6 Except SP-5B00
- *7 Except ST-6200
- *8 When using a Terminal Block Conversion Adapter (CA3-ADPTRM-01) instead of the RS-422 Terminal Block Conversion Adapter, refer to Cable Diagram 1A.
- *9 Available to use only the COM ports which can communicate in RS422/485(4 wire).
☞ "■ IPC COM Port" (page 4)

NOTE

- Termination resistance (100Ω) between RD-H and RD-L is incorporated in the LPU module and LQE565 of the External Device.
-

1A)

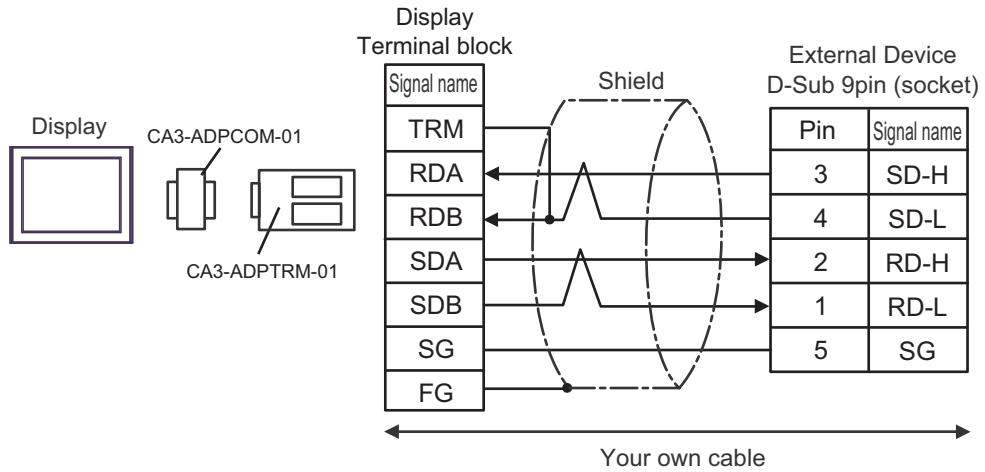

1B)

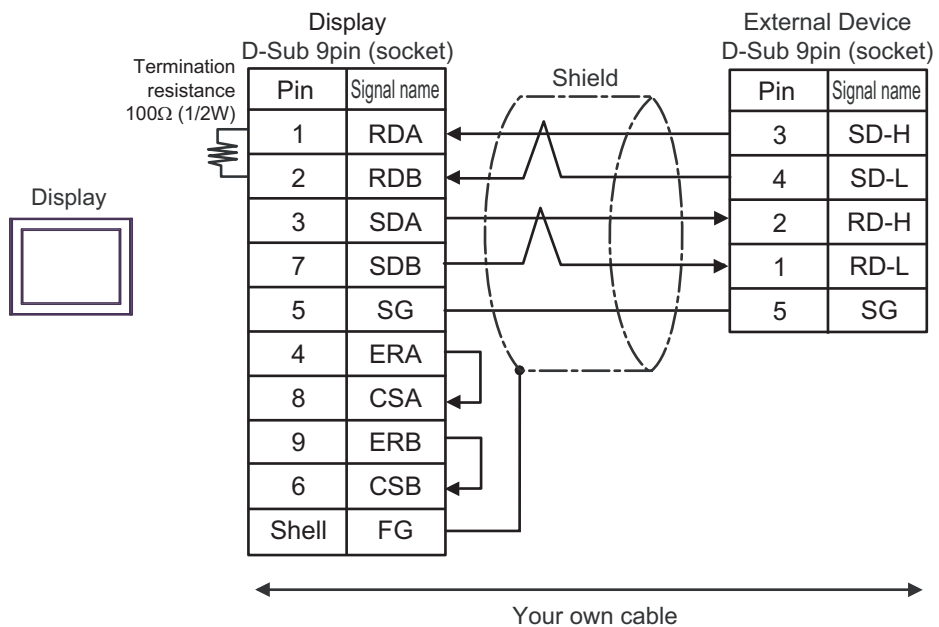

1C)

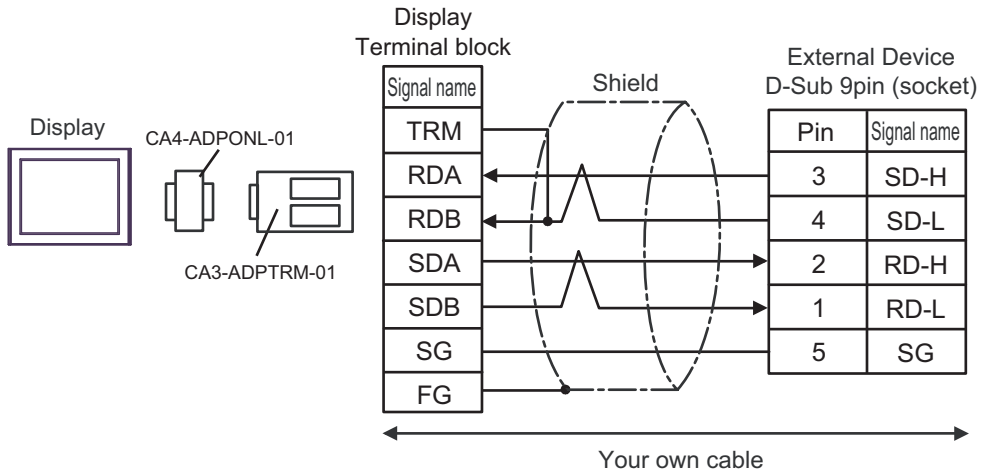

1D)

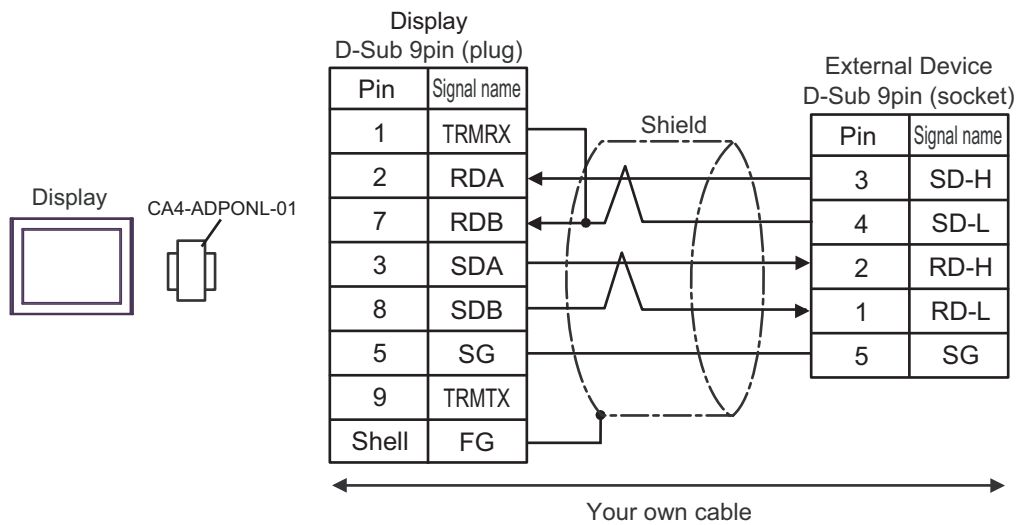

1E)

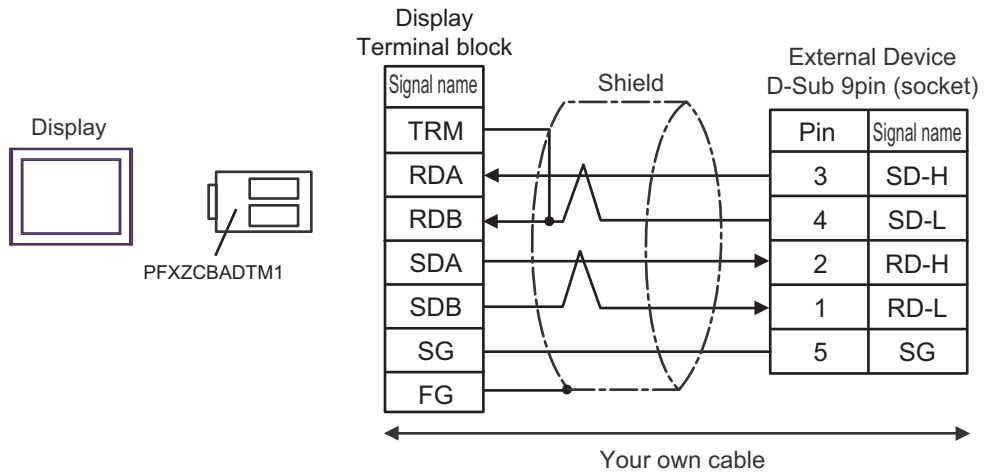

1F)

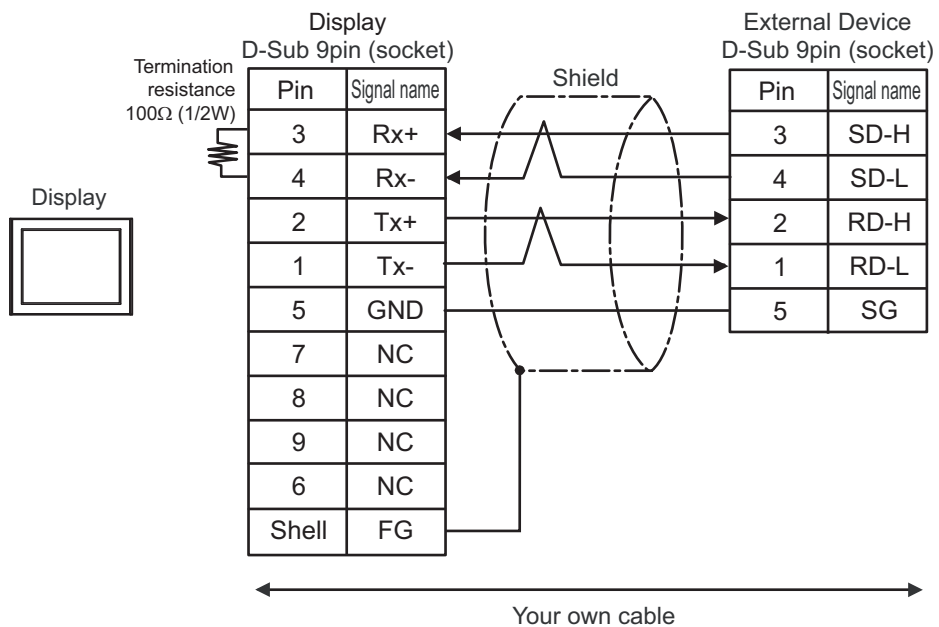

1G)

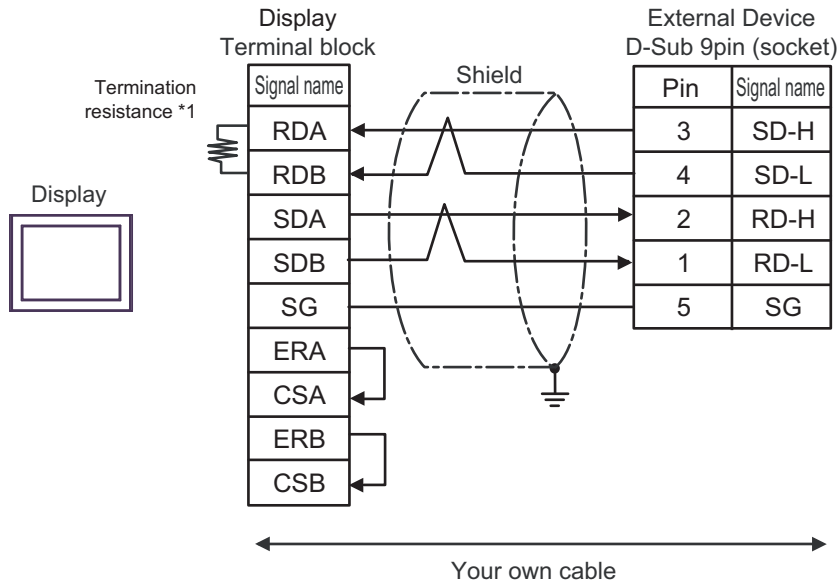

*1 The resistance in the Display is used as the termination resistance. Set the value of the DIP Switch on the rear of the Display as shown in the table below.

DIP Switch No.	Set Value
1	OFF
2	OFF
3	ON
4	ON

Cable Diagram 2

Display (Connection Port)	Cable		Remarks
GP3000 (COM1) GP4000* ¹ (COM1) SP5000* ² (COM1/2) SP-5B00 (COM1) ST3000 (COM1) ST6000 (COM1) STM6000 (COM1) STC6000 (COM1) LT3000 (COM1) IPC* ³ PC/AT	2A	Your own cable	Cable length: 15m or less
GP-4115T (COM1) GP-4115T3 (COM1)	2B	Your own cable	Cable length: 15m or less

*1 All GP4000 models except GP-4100 Series and GP-4203T

*2 Except SP-5B00

*3 Available to use only the COM ports which can communicate in RS232C.
☞ "■ IPC COM Port" (page 4)

2A)

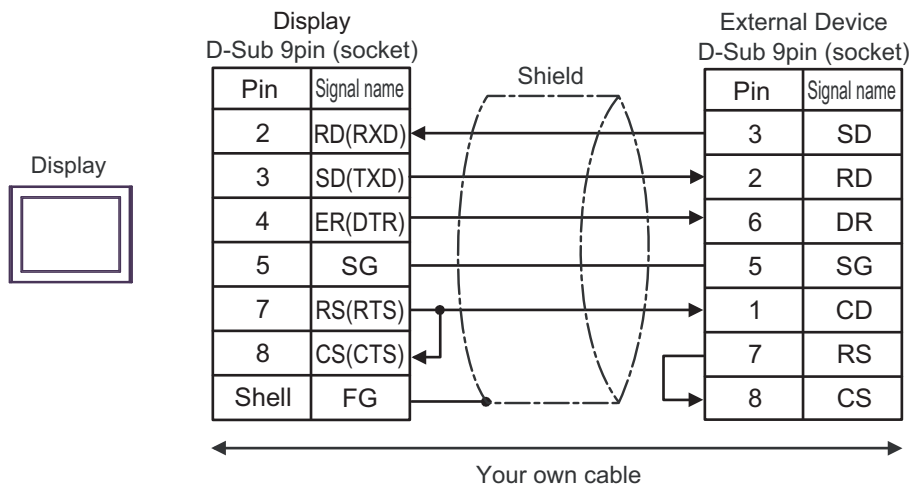

2B)

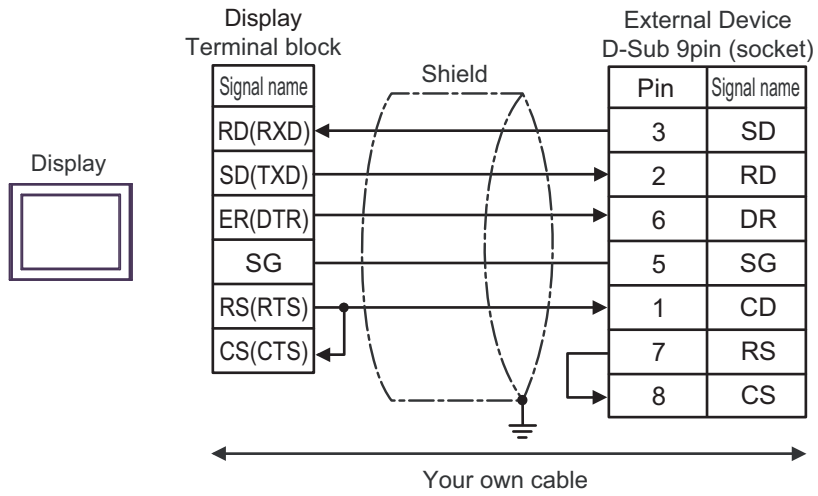

Cable Diagram 3

Display (Connection Port)	Cable		Remarks
GP3000* ¹ (COM1) AGP-3302B (COM2) GP-4*01TM (COM1) GP-Rear Module (COM1) ST3000* ² (COM2) LT3000 (COM1) IPC* ³	3A	COM port conversion adapter by Pro-face CA3-ADPCOM-01 + Connector terminal block conversion adapter by Pro-face CA3-ADPTRM-01 + Your own cable	Please refer to the manual of the External Device for cable length.
	3B	Your own cable	
GP3000* ⁴ (COM2)	3C	Online adapter by Pro-face CA4-ADPONL-01 + Connector terminal block conversion adapter by Pro-face CA3-ADPTRM-01 + Your own cable	Please refer to the manual of the External Device for cable length.
	3D	Online adapter by Pro-face CA4-ADPONL-01 + Your own cable	
GP-4116T (COM1)	3G	Your own cable	Please refer to the manual of the External Device for cable length.
GP4000* ⁵ (COM2) GP-4201T (COM1) SP5000* ⁶ (COM1/2) SP-5B00 (COM2) ST6000* ⁷ (COM2) ST-6200 (COM1) STM6000 (COM1) STC6000 (COM1) PS6000 (Basic Box) (COM1/2)	3E	RS-422 Terminal Block Conversion Adapter by Pro-face PFXZCBADTM1* ⁸ + Your own cable	Please refer to the manual of the External Device for cable length.
	3B	Your own cable	
PE-4000B* ⁹ PS5000* ⁹ PS6000 (Optional Interface)* ⁹	3F	Your own cable	Please refer to the manual of the External Device for cable length.

*1 All GP models except AGP-3302B

*2 Except AST-3211A and AST-3302B

*3 Available to use only the COM ports which can communicate in RS422/485(4 wire). (Except PE-4000B, PS5000, and PS6000)
☞ "■ IPC COM Port" (page 4)

*4 All GP models except GP-3200 Series and AGP-3302B

*5 All GP4000 models except GP-4100 Series, GP-4*01TM, GP-Rear Module, GP-4201T and GP-4*03T

*6 Except SP-5B00

- *7 Except ST-6200
- *8 When using a Terminal Block Conversion Adapter (CA3-ADPTRM-01) instead of the RS-422 Terminal Block Conversion Adapter, refer to Cable Diagram 3A.
- *9 Available to use only the COM ports which can communicate in RS422/485(4 wire).
 ■ "IPC COM Port" (page 4)

3A)

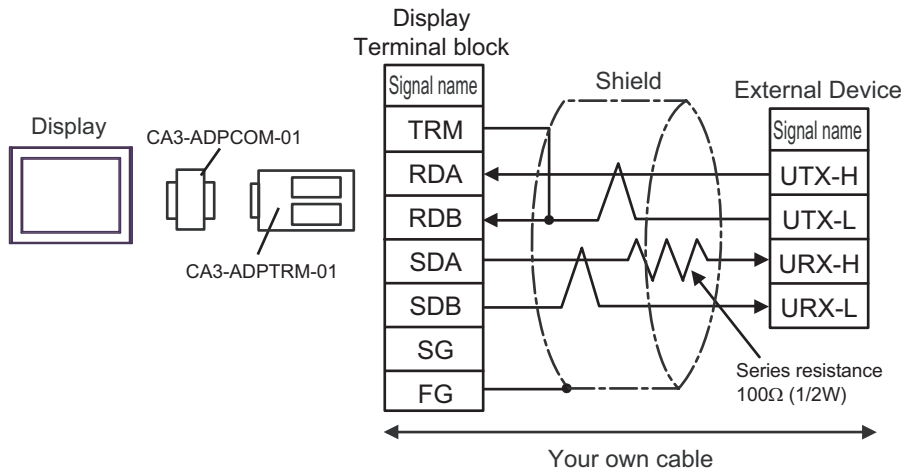

3B)

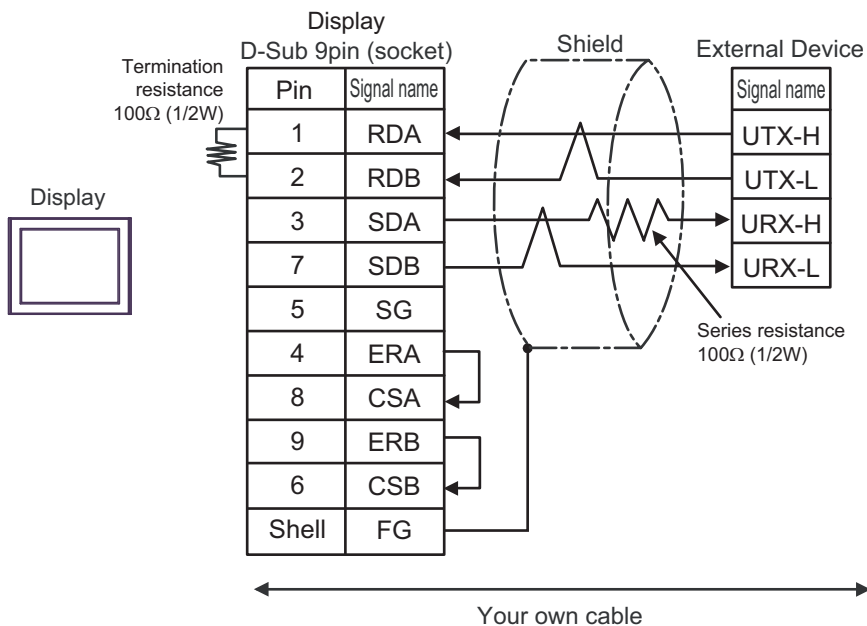
**NOTE**

- When making your own connections, we recommend using KPEV-SB-3P 0.5mm² cable by Hitachi Cable, Ltd..

3C)

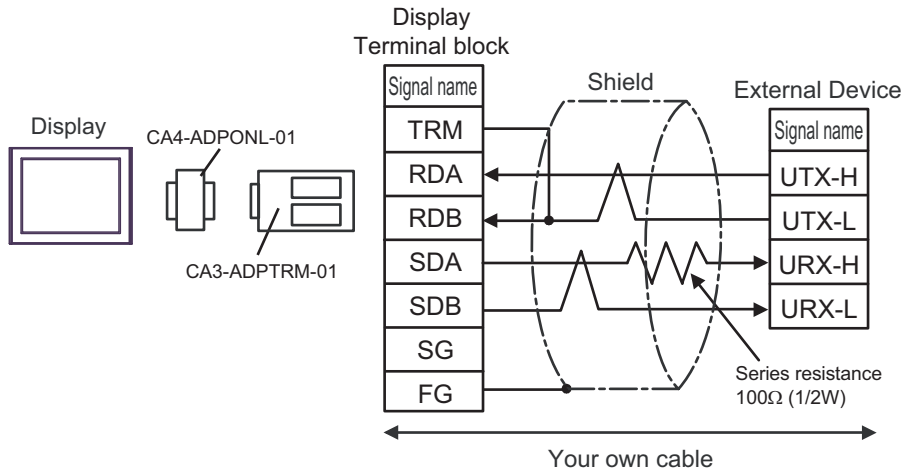

3D)

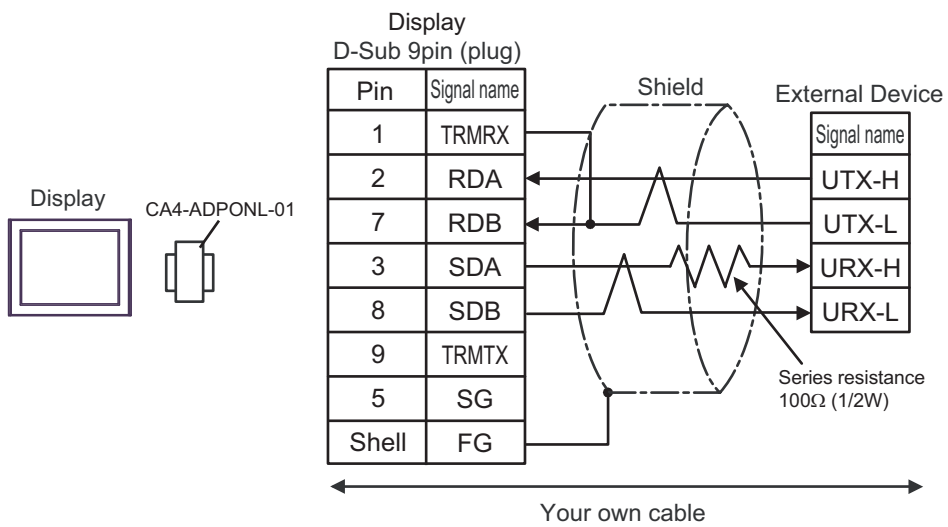

3E)

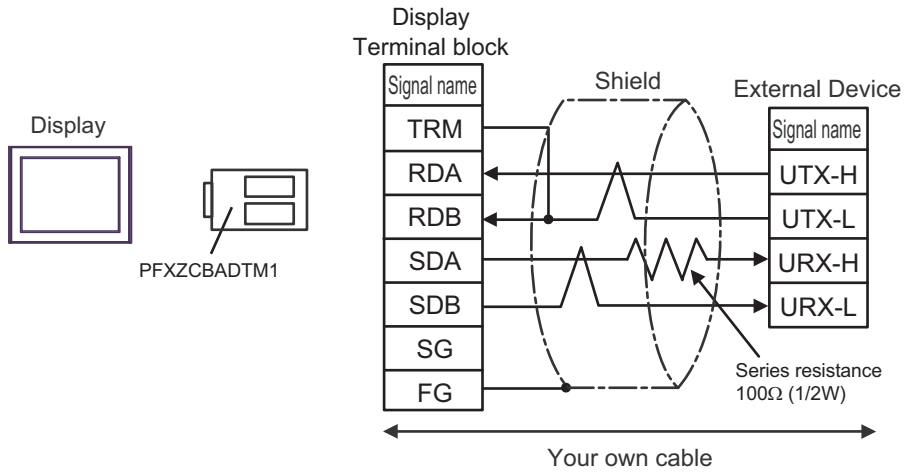

3F)

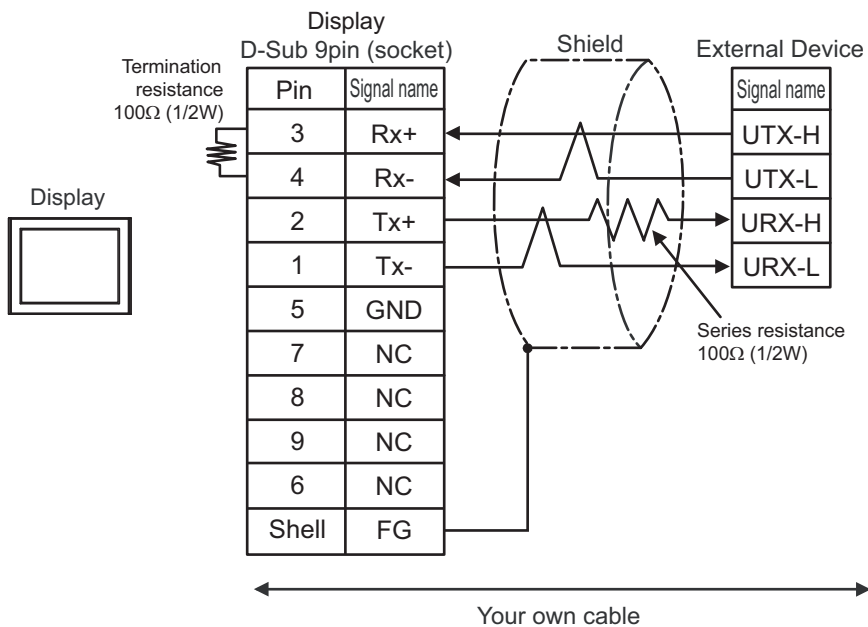
**NOTE**

- When making your own connections, we recommend using KPEV-SB-3P 0.5mm² cable by Hitachi Cable, Ltd..

3G)

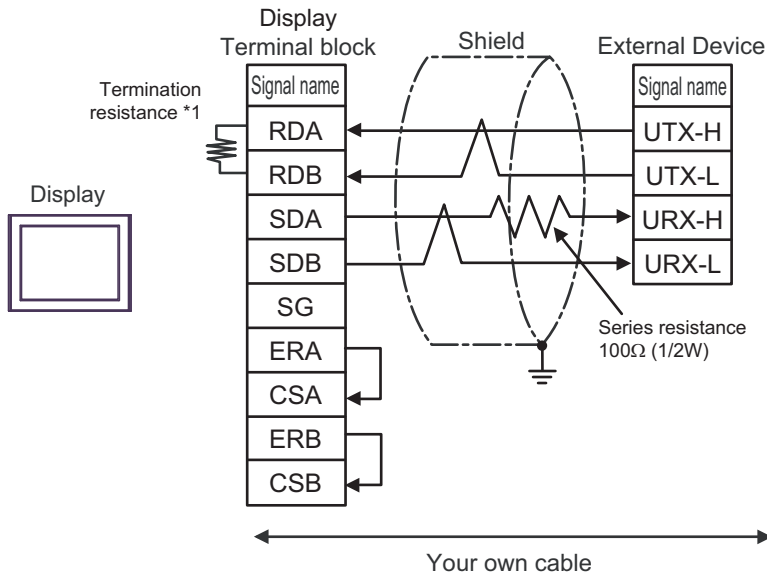
**NOTE**

- When making your own connections, we recommend using KPEV-SB-3P 0.5mm² cable by Hitachi Cable, Ltd..

*1 The resistance in the Display is used as the termination resistance. Set the value of the DIP Switch on the rear of the Display as shown in the table below.

DIP Switch No.	Set Value
1	OFF
2	OFF
3	ON
4	ON

6 Supported Device

Range of supported device address is shown in the table below. Note that the actually supported range varies depending on the External Device to be used. Please check the actual range in the manual of your External Device.

6.1 S10V Series

 : This address can be specified as system data area.

Device	Bit Address	Word Address	32 bits	Remarks
External Input	X000 - XFFF	XW000 - XWFF0	H / L	***0 *1
External Output	Y000 - YFFF	YW000 - YWFF0		***0 *1
Internal Register	R000 - RFFF	RW000 - RWFF0		***0 *1
Global Link Register	G000 - GFFF	GW000 - GWFF0		***0 *1
Event Register	E000 - E3FF	EW000 - EW3F0		***0 *1
Event Register	EW400 - EWFFF	EW400 - EWFF0		***0 *1 *2
Keep Relay	K000 - KFFF	KW000 - KWFF0		***0 *1
System Register	S000 - SBFF	SW000 - SWBF0		***0 *1 *3
On-delay Timer	T000 - T7FF	TW000 - TW7F0		***0 *1 *4
One-shot Timer	U000 - U0FF	UW000 - UW0F0		***0 *1
Up-Down Counter	C000 - C0FF	CW000 - CW0F0		***0 *1
Transfer Register	J000 - JFFF	JW000 - JWFF0		***0 *1
Receive Register	Q000 - QFFF	QW000 - QWFF0		***0 *1
Extended Internal Register	M000 - MFFF	MW000 - MWFF0		***0 *1
Extended Internal Register	A000 - AFFF	AW000 - AWFF0	***0 *1	

Device	Bit Address	Word Address	32 bits	Remarks
Timer (Elapsed Value)	-	TC000 - TC1FF	L/H	
Timer (Setup Value)	-	TS000 - TS1FF		
One-shot Timer (Elapsed Value)	-	UC000 - UC0FF		
One-shot Timer (Setup Value)	-	US000 - US0FF		
Counter (Elapsed Value)	-	CC000 - CC0FF		
Counter (Setup Value)	-	CS000 - CS0FF		
Work Register	-	FW000 - FWBFF	H/L	Bit F
Data Register	-	DW000 - DWFFF		Bit F
Work Register	LB0000 - LBFFFF	LBW0000 - LBWFFFF0		*** 0
Work Register for Ladder Converter	LR0000 - LR0FFF	LRW0000 - LRW0FFF0		*** 0
Work Register for Ladder Converter (Edge)	LV0000 - LV0FFF	LVW0000 - LVW0FFF0		*** 0
Work Register for Word	-	LWW0000 - LWWFFFFF		Bit F
Work Register for Long Word	-	LLL0000 - LLL1FFF		Bit 31 *5
Work Register for Floating Point	-	LF0000 - LF1FFF		*5 *6
Work Register for Word (Save during power OFF)	-	LXW0000 - LXW3FFF		Bit F
Work Register for Long Word (Save during power OFF)	-	LML0000 - LML1FFF		Bit 31 *5
Work Register for Floating Point (Save during power OFF)	-	LG0000 - LG1FFF		*5 *6
Direct Memory Address ^{*7}	-	DM00000000 - DMFFFFFFFE		Bit F ÷ 2

*1 According to External Device specification, the highest bit is "0" and the lowest bit is "15". When the highest bit turns ON, that bit is considered the highest and "32768" is written to that word.

Ex. When writing bit from the Display is "X000(ON)," the External Device's bit device "X000" turns ON.

At this time the Display and External Device word device "XW000" become "32768(0x8000)".

*2 The higher and lower bit order will be reversed. When EW400 is turned ON, E40F will be turned ON on the External Device.

*3 Data cannot be written.

*4 If the CPU version is prior to Ver.1, the bit address becomes "T000 to T1FF" and the word address becomes "TW000 to TW1F0."

*5 A 32-bit device.

*6 A float decimal point device (32 bits).

*7 Used to access the memory address of the External Device.

IMPORTANT

- When you access the External Device using the Direct Memory Address, do not access the memory address that the system uses. If you conduct it, an error may occur. For details concerning the address, refer to the manual attached to the External Device.

NOTE

- Please refer to the GP-Pro EX Reference Manual for system data area.















Cf. GP-Pro EX Reference Manual "LS Area (Direct Access Method Area)"





- Please refer to the precautions on manual notation for icons in the table.

 "Manual Symbols and Terminology"

6.2 HIDIC-S10 α (2 α /2 α E/2 α H)

 : This address can be specified as system data area.

Device	Bit Address	Word Address	32 bits	Remarks
External Input	X000 - XFFF	XW000 - XWFFF0		 *1
External Output	Y000 - YFFF	YW000 - YWFFF0		 *1
Intermediate Register	R000 - RFFF	RW000 - RWFFF0		 *1
Global Link Register	G000 - GFFF	GW000 - GWFFF0		 *1
Event Register	E000 - E3FF	EW000 - EW3FF0		 *1
Keep Relay	K000 - KFFF	KW000 - KWFFF0		 *1
System Register	S000 - SBFF	SW000 - SWBFF0		 *1 *2
Timer	T000 - T1FF	TW000 - TW1FF0		 *1
One Shot	U000 - U0FF	UW000 - UW0FF0		 *1
Counter	C000 - C0FF	CW000 - CW0FF0		 *1
Transfer Register	J000 - JFFF	JW000 - JWFFF0		 *1
Receive Register	Q000 - QFFF	QW000 - QWFFF0		 *1
Extended Internal Register	M000 - MFFF	MW000 - MWFFF0		 *1
On-Delay Timer (Elapsed Value)	-	TC000 - TC1FF		
On-Delay Timer (Setup Value)	-	TS000 - TS1FF		
One Shot Timer (Elapsed Value)	-	UC000 - UC0FF		
One Shot Timer (Setup Value)	-	US000 - US0FF		
Up/Down Counter (Elapsed Value)	-	CC000 - CC0FF		
Up/Down Counter (Setup Value)	-	CS000 - CS0FF		

Device	Bit Address	Word Address	32 bits	Remarks
Function Work Register	-	FW000 - FWBFF	H/L	
Function Data Register	-	DW000 - DWFFF		
Extended Register	-	MS000 - MSFFF		 *3
Direct Memory Address*4	-	DM00000000 - DMFFFFFFFE		 

*1 According to External Device specification, the highest bit is "0" and the lowest bit is "15". When the highest bit turns ON, that bit is considered the highest and "32768" is written to that word.

Ex. When writing bit from the Display is "X000(ON)," the External Device's bit device "X000" turns ON.
At this time the Display and External Device word device "XW000" become "32768(0x8000)".

*2 Data cannot be written.

*3 In expanded memory in External Device (1 address = 8 bits), 4096 Words can be accessed.
Set top address of expanded memory to be accessed by "Device Setting."
Refer to the External Device manual for how to set address area for External Device expanded memory.

◆ Accessed Expanded Memory Address

Access Address (The absolute address in External Device) = (1) + (2) + (3)

(1)	Top Address (HEX)	This value is been set in " ■ Device Setting" (page 19).
(2)	100000 (HEX)	Offset value
(3)	Device Address × 2 (HEX)	Since the External Device uses 8 bits for its expanded memory address, this number is doubled.

Ex. When the Top Address is "180000" and the Device Address is "MS1FF".

Then the absolute address in External Device (Access Address) is "180000 + 100000 + 3FE = 2803FE".

NOTE

An error may occur on the External Device or Display if the area that is being used for programs on the External Device is accessed from the Display.

We recommend that you set [Expanded Memory Addresses] to an area that is not used by the External Device.

*4 Used to access the memory address of the External Device.

IMPORTANT















- When you access the External Device using the Direct Memory Address, do not access the memory address that the system uses. If you conduct it, an error may occur. For details concerning the address, refer to the manual attached to the External Device.





NOTE

- Please refer to the GP-Pro EX Reference Manual for system data area.
Cf. GP-Pro EX Reference Manual "LS Area (Direct Access Method Area)"
- Please refer to the precautions on manual notation for icons in the table.
 "Manual Symbols and Terminology"

6.3 HIDIC-S10 α (4 α /4 α F)

 : This address can be specified as system data area.

Device	Bit Address	Word Address	32 bits	Remarks
External Input	X000 - XFFF	XW000 - XWFF0		 *1
External Output	Y000 - YFFF	YW000 - YWFF0		 *1
Intermediate Register	R000 - RFFF	RW000 - RWFF0		 *1
Global Link Register	G000 - GFFF	GW000 - GWFF0		 *1
Event Register	E000 - E3FF	EW000 - EW3F0		 *1
Keep Relay	K000 - KFFF	KW000 - KWFF0		 *1
System Register	S000 - SBFF	SW000 - SWBF0		 *1 *2
Timer	T000 - T1FF	TW000 - TW1F0		 *1
One Shot	U000 - U0FF	UW000 - UW0F0		 *1
Counter	C000 - C0FF	CW000 - CW0F0		 *1
Transfer Register	J000 - JFFF	JW000 - JWFF0		 *1
Receive Register	Q000 - QFFF	QW000 - QWFF0		 *1
Extended Internal Register	M000 - MFFF	MW000 - MWFF0		 *1
On-Delay Timer (Elapsed Value)	-	TC000 - TC1FF		
On-Delay Timer (Setup Value)	-	TS000 - TS1FF		
One Shot Timer (Elapsed Value)	-	UC000 - UC0FF		
One Shot Timer (Setup Value)	-	US000 - US0FF		
Up/Down Counter (Elapsed Value)	-	CC000 - CC0FF		
Up/Down Counter (Setup Value)	-	CS000 - CS0FF		

Device	Bit Address	Word Address	32 bits	Remarks
Function Work Register	-	FW000 - FWBFF	H/L	
Function Data Register	-	DW000 - DW7FF		
Direct Memory Address ^{*3}	-	DM00000000 - DMFFFFFFFE		 

*1 According to External Device specification, the highest bit is "0" and the lowest bit is "15". When the highest bit turns ON, that bit is considered the highest and "32768" is written to that word.

Ex. When writing bit from the Display is "X000(ON)," the External Device's bit device "X000" turns ON.
At this time the Display and External Device word device "XW000" become "32768(0x8000)".

*2 Data cannot be written.

*3 Used to access the memory address of the External Device.

IMPORTANT















- When you access the External Device using the Direct Memory Address, do not access the memory address that the system uses. If you conduct it, an error may occur. For details concerning the address, refer to the manual attached to the External Device.
-

NOTE

- Please refer to the GP-Pro EX Reference Manual for system data area.
Cf. GP-Pro EX Reference Manual "LS Area (Direct Access Method Area)"
 - Please refer to the precautions on manual notation for icons in the table.
 "Manual Symbols and Terminology"
-

6.4 S10mini Series

 : This address can be specified as system data area.

Device	Bit Address	Word Address	32 bits	Remarks
External Input	X000 - XFFF	XW000 - XWFFF0	H / L	 *1
External Output	Y000 - YFFF	YW000 - YWFFF0		 *1
Internal Register	R000 - RFFF	RW000 - RWFFF0		 *1
Global Link Register	G000 - GFFF	GW000 - GWFFF0		 *1
Event Register	E000 - E3FF	EW000 - EW3F0		 *1
Event Register	EW400 - EWFFF	EW400 - EWFFF0		 *1 *2
Keep Relay	K000 - KFFF	KW000 - KWFFF0		 *1
System Register	S000 - SBFF	SW000 - SWBFF0		 *1 *3
On-Delay Timer	T000 - T1FF	TW000 - TW1F0		 *1
One Shot Timer	U000 - U0FF	UW000 - UW0F0		 *1
Up/Down Counter	C000 - C0FF	CW000 - CW0F0		 *1
Transfer Register	J000 - JFFF	JW000 - JWFFF0		 *1
Receive Register	Q000 - QFFF	QW000 - QWFFF0		 *1
Extended Internal Register	M000 - MFFF	MW000 - MWFFF0		 *1
On-Delay Timer (Elapsed Value)	-	TC000 - TC1FF	L / H	
On-Delay Timer (Setup Value)	-	TS000 - TS1FF		
One Shot Timer (Elapsed Value)	-	UC000 - UC0FF		
One Shot Timer (Setup Value)	-	US000 - US0FF		
Up/Down Counter (Elapsed Value)	-	CC000 - CC0FF		
Up/Down Counter (Setup Value)	-	CS000 - CS0FF		

Device	Bit Address	Word Address	32 bits	Remarks
Work Register	-	FW000 - FWBFF	H/L	Bit F
Data Register	-	DW000 - DWFFF		Bit F
Extended Register	-	MS000 - MSFFF		Bit F *4
Direct Memory Address *5	-	DM00000000 - DMFFFFFFFE		Bit F ÷ 2

*1 According to External Device specification, the highest bit is "0" and the lowest bit is "15". When the highest bit turns ON, that bit is considered the highest and "32768" is written to that word.

Ex. When writing bit from the Display is "X000(ON)," the External Device's bit device "X000" turns ON.

At this time the Display and External Device word device "XW000" become "32768(0x8000)".

*2 The higher and lower bit order will be reversed. When EW400 is turned ON, E40F will be turned ON on the External Device.

*3 Data cannot be written.

*4 In expanded memory in External Device (1 address = 8 bits), 4096 Words can be accessed.

Set top address of expanded memory to be accessed by "Device Setting."

Refer to the External Device manual for how to set address area for External Device expanded memory.

◆ Accessed Expanded Memory Address

Access Address (The absolute address in External Device) = (1) + (2) + (3)

(1)	Top Address (HEX)	This value is been set in " ■ Device Setting" (page 19).
(2)	100000 (HEX)	Offset value
(3)	Device Address × 2 (HEX)	Since the External Device uses 8 bits for its expanded memory address, this number is doubled.

Ex. When the Top Address is "180000" and the Device Address is "MS1FF".

Then the absolute address in External Device (Access Address) is "180000 + 100000 + 3FE = 2803FE".

NOTE

- An error may occur on the External Device or Display if the area that is being used for programs on the External Device is accessed from the Display.
We recommend that you set [Expanded Memory Addresses] to an area that is not used by the External Device.

*5 Used to access the memory address of the External Device.

IMPORTANT

- When you access the External Device using the Direct Memory Address, do not access the memory address that the system uses. If you conduct it, an error may occur. For details concerning the address, refer to the manual attached to the External Device.

NOTE

- Please refer to the GP-Pro EX Reference Manual for system data area.

Cf. GP-Pro EX Reference Manual "LS Area (Direct Access Method Area)"

- Please refer to the precautions on manual notation for icons in the table.

☞ "Manual Symbols and Terminology"

7 Device Code and Address Code

Use device code and address code when you select "Device Type & Address" for the address type in data displays.

7.1 S10V Series

Device	Device Name	Device Code (HEX)	Address Code
External Input	X	0080	Value of word address divided by 0x10
	XW		
External Output	Y	0081	Value of word address divided by 0x10
	YW		
Internal Register	R	0082	Value of word address divided by 0x10
	RW		
Global Link Register	G	0083	Value of word address divided by 0x10
	GW		
Event Register	E	0084	Value of word address divided by 0x10
	EW		
Event Register	EW	0091	Value of word address divided by 0x10
	EW		
Keep Relay	K	0085	Value of word address divided by 0x10
	KW		
System Register	S	0086	Value of word address divided by 0x10
	SW		
On-delay Timer	T	0087	Value of word address divided by 0x10
	TW		
One-shot Timer	U	0088	Value of word address divided by 0x10
	UW		
Up-Down Counter	C	0089	Value of word address divided by 0x10
	CW		
Transfer Register	J	008A	Value of word address divided by 0x10
	JW		
Receive Register	Q	008B	Value of word address divided by 0x10
	QW		
Extended Internal Register	M	008C	Value of word address divided by 0x10
	MW		
Extended Internal Register	A	008D	Value of word address divided by 0x10
	AW		
Timer (Elapsed Value)	TC	0060	Word Address

Device	Device Name	Device Code (HEX)	Address Code
Timer (Setup Value)	TS	0061	Word Address
One-shot Timer (Elapsed Value)	UC	0062	Word Address
One-shot Timer (Setup Value)	US	0063	Word Address
Counter (Elapsed Value)	CC	0064	Word Address
Counter (Setup Value)	CS	0065	Word Address
Work Register	FW	0001	Word Address
Data Register	DW	0000	Word Address
Work Register	LB	008E	Value of word address divided by 0x10
	LBW		
Work Register for Ladder Converter	LR	008F	Value of word address divided by 0x10
	LRW		
Work Register for Ladder Converter (Edge)	LV	0090	Value of word address divided by 0x10
	LVW		
Work Register for Word	LWW	0002	Word Address
Work Register for Long Word	LLL	0003	Word Address
Work Register for Floating Point	LF	0066	Word Address
Work Register for Word (Save during power OFF)	LXW	0004	Word Address
Work Register for Long Word (Save during power OFF)	LML	0005	Word Address
Work Register for Floating Point (Save during power OFF)	LG	0067	Word Address
Direct Memory Address (DM00000000 - DM0FFFFFFE)	DM	0007	Value of word address divided by 2
Direct Memory Address (DM10000000 - DM1FFFFFFE)		0008	
Direct Memory Address (DM20000000 - DM2FFFFFFE)		0009	
Direct Memory Address (DM30000000 - DM3FFFFFFE)		000A	
Direct Memory Address (DM40000000 - DM4FFFFFFE)		000B	
Direct Memory Address (DM50000000 - DM5FFFFFFE)		000C	
Direct Memory Address (DM60000000 - DM6FFFFFFE)		000D	
Direct Memory Address (DM70000000 - DM7FFFFFFE)		000E	

Device	Device Name	Device Code (HEX)	Address Code
Direct Memory Address (DM80000000 - DM8FFFFFFE)	DM	000F	Value of word address divided by 2
Direct Memory Address (DM90000000 - DM9FFFFFFE)		0010	
Direct Memory Address (DMA00000000 - DMAFFFFFFE)		0011	
Direct Memory Address (DMB00000000 - DMBFFFFFFE)		0012	
Direct Memory Address (DMC00000000 - DMCFFFFFFE)		0013	
Direct Memory Address (DMD00000000 - DMDFFFFFFE)		0014	
Direct Memory Address (DME00000000 - DMEFFFFFFE)		0015	
Direct Memory Address (DMF00000000 - DMFFFFFFE)		0016	

7.2 HIDIC-S10 α (2 α /2 α E/2 α H)

Device	Device Name	Device Code (HEX)	Address Code
External Input	X	0080	Value of word address divided by 0x10
	XW		
External Output	Y	0081	Value of word address divided by 0x10
	YW		
Intermediate Register	R	0082	Value of word address divided by 0x10
	RW		
Global Link Register	G	0083	Value of word address divided by 0x10
	GW		
Event Register	E	0084	Value of word address divided by 0x10
	EW		
Keep Relay	K	0085	Value of word address divided by 0x10
	KW		
System Register	S	0086	Value of word address divided by 0x10
	SW		
Timer	T	0087	Value of word address divided by 0x10
	TW		
One Shot	U	0088	Value of word address divided by 0x10
	UW		
Counter	C	0089	Value of word address divided by 0x10
	CW		
Transfer Register	J	008A	Value of word address divided by 0x10
	JW		
Receive Register	Q	008B	Value of word address divided by 0x10
	QW		
Extended Internal Register	M	008C	Value of word address divided by 0x10
	MW		
On-Delay Timer (Elapsed Value)	TC	0060	Word Address
On-Delay Timer (Setup Value)	TS	0061	Word Address
One Shot Timer (Elapsed Value)	UC	0062	Word Address
One Shot Timer (Setup Value)	US	0063	Word Address
Up/Down Counter (Elapsed Value)	CC	0064	Word Address
Up/Down Counter (Setup Value)	CS	0065	Word Address
Function Work Register	FW	0001	Word Address
Function Data Register	DW	0000	Word Address
Extended Register	MS	0006	Word Address

Device	Device Name	Device Code (HEX)	Address Code
Direct Memory Address (DM00000000 - DM0FFFFFFE)	DM	0007	Value of word address divided by 2
Direct Memory Address (DM10000000 - DM1FFFFFFE)		0008	
Direct Memory Address (DM20000000 - DM2FFFFFFE)		0009	
Direct Memory Address (DM30000000 - DM3FFFFFFE)		000A	
Direct Memory Address (DM40000000 - DM4FFFFFFE)		000B	
Direct Memory Address (DM50000000 - DM5FFFFFFE)		000C	
Direct Memory Address (DM60000000 - DM6FFFFFFE)		000D	
Direct Memory Address (DM70000000 - DM7FFFFFFE)		000E	
Direct Memory Address (DM80000000 - DM8FFFFFFE)		000F	
Direct Memory Address (DM90000000 - DM9FFFFFFE)		0010	
Direct Memory Address (DMA0000000 - DMAFFFFFFE)		0011	
Direct Memory Address (DMB0000000 - DMBFFFFFFE)		0012	
Direct Memory Address (DMC0000000 - DMCFFFFFFE)		0013	
Direct Memory Address (DMD0000000 - DMDFFFFFFE)		0014	
Direct Memory Address (DME0000000 - DMEFFFFFFE)		0015	
Direct Memory Address (DMF0000000 - DMFFFFFFE)		0016	

7.3 HIDIC-S10 α (4 α /4 α F)

Device	Device Name	Device Code (HEX)	Address Code
External Input	X	0080	Value of word address divided by 0x10
	XW		
External Output	Y	0081	Value of word address divided by 0x10
	YW		
Intermediate Register	R	0082	Value of word address divided by 0x10
	RW		
Global Link Register	G	0083	Value of word address divided by 0x10
	GW		
Event Register	E	0084	Value of word address divided by 0x10
	EW		
Keep Relay	K	0085	Value of word address divided by 0x10
	KW		
System Register	S	0086	Value of word address divided by 0x10
	SW		
Timer	T	0087	Value of word address divided by 0x10
	TW		
One Shot	U	0088	Value of word address divided by 0x10
	UW		
Counter	C	0089	Value of word address divided by 0x10
	CW		
Transfer Register	J	008A	Value of word address divided by 0x10
	JW		
Receive Register	Q	008B	Value of word address divided by 0x10
	QW		
Extended Internal Register	M	008C	Value of word address divided by 0x10
	MW		
On-Delay Timer (Elapsed Value)	TC	0060	Word Address
On-Delay Timer (Setup Value)	TS	0061	Word Address
One Shot Timer (Elapsed Value)	UC	0062	Word Address
One Shot Timer (Setup Value)	US	0063	Word Address
Up/Down Counter (Elapsed Value)	CC	0064	Word Address
Up/Down Counter (Setup Value)	CS	0065	Word Address
Function Work Register	FW	0001	Word Address
Function Data Register	DW	0000	Word Address

Device	Device Name	Device Code (HEX)	Address Code
Direct Memory Address (DM00000000 - DM0FFFFFFE)	DM	0007	Value of word address divided by 2
Direct Memory Address (DM10000000 - DM1FFFFFFE)		0008	
Direct Memory Address (DM20000000 - DM2FFFFFFE)		0009	
Direct Memory Address (DM30000000 - DM3FFFFFFE)		000A	
Direct Memory Address (DM40000000 - DM4FFFFFFE)		000B	
Direct Memory Address (DM50000000 - DM5FFFFFFE)		000C	
Direct Memory Address (DM60000000 - DM6FFFFFFE)		000D	
Direct Memory Address (DM70000000 - DM7FFFFFFE)		000E	
Direct Memory Address (DM80000000 - DM8FFFFFFE)		000F	
Direct Memory Address (DM90000000 - DM9FFFFFFE)		0010	
Direct Memory Address (DMA0000000 - DMAFFFFFFE)		0011	
Direct Memory Address (DMB0000000 - DMBFFFFFFE)		0012	
Direct Memory Address (DMC0000000 - DMCFFFFFFE)		0013	
Direct Memory Address (DMD0000000 - DMDFFFFFFE)		0014	
Direct Memory Address (DME0000000 - DMEFFFFFFE)		0015	
Direct Memory Address (DMF0000000 - DMFFFFFFE)		0016	

7.4 S10mini Series

Device	Device Name	Device Code (HEX)	Address Code
External Input	X	0080	Value of word address divided by 0x10
	XW		
External Output	Y	0081	Value of word address divided by 0x10
	YW		
Internal Register	R	0082	Value of word address divided by 0x10
	RW		
Global Link Register	G	0083	Value of word address divided by 0x10
	GW		
Event Register	E	0084	Value of word address divided by 0x10
	EW		
Event Register	EW	0091	Value of word address divided by 0x10
	EW		
Keep Relay	K	0085	Value of word address divided by 0x10
	KW		
System Register	S	0086	Value of word address divided by 0x10
	SW		
On-Delay Timer	T	0087	Value of word address divided by 0x10
	TW		
One Shot Timer	U	0088	Value of word address divided by 0x10
	UW		
Up/Down Counter	C	0089	Value of word address divided by 0x10
	CW		
Transfer Register	J	008A	Value of word address divided by 0x10
	JW		
Receive Register	Q	008B	Value of word address divided by 0x10
	QW		
Extended Internal Register	M	008C	Value of word address divided by 0x10
	MW		
On-Delay Timer (Elapsed Value)	TC	0060	Word Address
On-Delay Timer (Setup Value)	TS	0061	Word Address
One Shot Timer (Elapsed Value)	UC	0062	Word Address
One Shot Timer (Setup Value)	US	0063	Word Address
Up/Down Counter (Elapsed Value)	CC	0064	Word Address
Up/Down Counter (Setup Value)	CS	0065	Word Address
Work Register	FW	0001	Word Address

Device	Device Name	Device Code (HEX)	Address Code
Data Register	DW	0000	Word Address
Extended Register	MS	0006	Word Address
Direct Memory Address (DM00000000 - DM0FFFFFFE)	DM	0007	Value of word address divided by 2
Direct Memory Address (DM10000000 - DM1FFFFFFE)		0008	
Direct Memory Address (DM20000000 - DM2FFFFFFE)		0009	
Direct Memory Address (DM30000000 - DM3FFFFFFE)		000A	
Direct Memory Address (DM40000000 - DM4FFFFFFE)		000B	
Direct Memory Address (DM50000000 - DM5FFFFFFE)		000C	
Direct Memory Address (DM60000000 - DM6FFFFFFE)		000D	
Direct Memory Address (DM70000000 - DM7FFFFFFE)		000E	
Direct Memory Address (DM80000000 - DM8FFFFFFE)		000F	
Direct Memory Address (DM90000000 - DM9FFFFFFE)		0010	
Direct Memory Address (DMA0000000 - DMAFFFFFFE)		0011	
Direct Memory Address (DMB0000000 - DMBFFFFFFE)		0012	
Direct Memory Address (DMC0000000 - DMCFFFFFFE)		0013	
Direct Memory Address (DMD0000000 - DMDFFFFFFE)		0014	
Direct Memory Address (DME0000000 - DMEFFFFFFE)		0015	
Direct Memory Address (DMF0000000 - DMFFFFFFE)	0016		

8 Error Messages

Error messages are displayed on the Display screen as follows: "No. : Device Name: Error Message(Error Occurrence Area)". Each description is shown below.

Item	Description
No.	Error No.
Device Name	Name of the External Device where an error occurs. Device name is a title of the External Device set with GP-Pro EX. (Initial value [PLC1])
Error Message	Displays messages related to the error that has occurred.
Error Occurrence Area	<p>Displays IP address or device address of the External Device where an error occurs, or error codes received from the External Device.</p> <p>NOTE</p> <ul style="list-style-type: none"> • IP address is displayed such as "IP address (Decimal): MAC address (Hex)". • Device address is displayed as "Address: Device address". • Received error codes are displayed such as "Decimal [Hex]".

Display Examples of Error Messages

"RHAA035: PLC1: Error has been responded for device write command (Error Code: 2 [02H])"

NOTE

- Refer to your External Device manual for details on received error codes.
- Refer to "Display-related errors" in "Maintenance/Troubleshooting Guide" for details on the error messages common to the driver.