



WARNINGS

System Design

- Do not create GP touch panel switches that could possibly endanger the safety of equipment and personnel. Damage to the GP, its I/O unit(s), cable(s), and other related equipment can cause an output signal to remain continuously ON or OFF and possibly cause a major accident. Therefore, design all monitoring circuits using limit switches, etc. to detect incorrect device movement. To prevent accidents related to incorrect device movement. To prevent accidents related to incorrect signal output or operation, design all switches used to control vital machine operations so they are operated via a separate control system.
- Do not create switches used to control machine safety operations, such as an emergency stop switch, as a GP touch screen icon. Be sure to install these switches as separate hardware switches, otherwise severe bodily injury or equipment damage can occur.
- Please design your system so that equipment will not malfunction due to a communication fault between the GP and its host controller. This is to prevent any possibility of bodily injury or material damage.
- Do not use the GP unit as a warning device for critical alarms that can cause serious operator injury, machine damage or production stoppage. Critical alarm indicators and their control/activator units must be designed using stand-alone hardware and/or mechanical interlocks.
- The GP is not appropriate for use with aircraft control devices, aerospace equipment, central trunk data transmission (communication) devices, nuclear power control devices, or medical life support equipment, due to these devices' inherent requirements of extremely high levels of safety and reliability.
- When using the GP with transportation vehicles (trains, cars and ships), disaster and crime prevention devices, various types of safety equipment, non-life support related medical devices, etc. redundant and/or failsafe system designs should be used to ensure the proper degree of reliability and safety.
- After the GP's backlight burns out, the touch panel is still active. If the operator fails to notice that the backlight is burned out and touches the panel, a potentially dangerous machine malfunction can occur. Therefore, do not use GP touch switches for the control of any equipment safety mechanisms, such as Emergency Stop switches, etc. that protect humans and equipment from injury and damage. If your GP's backlight suddenly turns OFF, use the following steps to determine if the backlight is actually burned out.
 - 1) When the backlight burnout feature is not set, and the screen has gone blank, your backlight is burned out.
 - 2) When the backlight burnout feature is set, and the screen has gone blank, if touching the screen does not cause the backlight to turn ON, your backlight is burned out.

Installation

- High voltage runs through the GP. Except for replacing the backlight, never disassemble the GP, otherwise an electric shock can occur.
- Do not modify the GP unit. Doing so may cause a fire or an electric shock.
- Do not use the GP in an environment where flammable gasses are present, since operating the GP may cause an explosion.

Wiring

- To prevent an electric shock, be sure to confirm that the GP's power cord is not connected to the main power when connecting any cords, cables or lines to the GP.
- Be sure to replace the GP's plastic terminal block cover after wiring is completed, since operating the GP without the cover may lead to an electric shock.
- Do not use power beyond the GP's specified voltage range. Doing so may cause a fire or an electric shock.

Maintenance

- The GP uses a lithium battery for backing up its internal clock data. If the battery is incorrectly replaced, the battery may explode. To prevent this, please do not replace the battery yourself. When the battery needs to be replaced, please contact your local GP distributor.



CAUTIONS

Installation

- Be sure to securely connect all cable connectors to the GP. A loose connection may cause incorrect input or output.

Wiring

- Ground the GP's FG line separately from other units' FG lines. Putting these FG lines too close may cause an electric shock or unit malfunction. Be sure to use a grounding resistance of 100Ω or less and a 2mm² or thicker wire, or your country's applicable standard.
- Correctly wire the GP, be sure that the rated voltage and terminal layout are within the designated range. If the voltage supplied differs from the rated voltage, or incorrect wiring or grounding is performed, it may cause a fire or unit malfunction.
- Use only the designated torque to tighten the GP's terminal block screws. If these screws are not tightened firmly, it may cause a short-circuit, fire, or GP malfunction.
- Be careful that metal filings and wiring debris do not fall inside the GP, since they can cause a fire, GP malfunction, or incorrect operation.

Maintenance

- The liquid crystal panel contains a powerful irritant and if for any reason the panel is damaged and this liquid contacts any part of your body, be sure to wash that area with running water for 15 minutes. If any of this liquid enters your eye, flush your eye for 15 minutes with running water and contact a physician.

Unit Disposal

- When this unit is disposed of, it should be done so according to your country's regulations for similar types of industrial waste.

General Safety Precautions

- Do not strike the touch panel with a hard or pointed object, or press on the touch panel with too much force, since it may damage the touch panel or the display.
- Do not install the GP where the ambient temperature can exceed the allowed range. Doing so may cause the GP to malfunction or shorten its operation life.
- Do not restrict or limit the GP's naturally occurring rear-face ventilation, or storing or using the GP in an environment that is too hot.
- Do not use this unit in areas where large, sudden temperature changes can occur. These changes can cause condensation to form inside the unit, possibly causing the unit to malfunction.
- Do not allow water, liquids, metal or charged particles to enter inside the GP's case, since they can cause either a GP malfunction or an electrical shock. The allowable pollution degree is 2.
- Do not use or store the GP in direct sunlight, or in excessively dusty or dirty environments.
- Do not store or use the unit where strong jolting or excessive vibration can occur.
- Do not store or use the GP where chemicals (such as organic solvents, etc.) and acids can evaporate, or where chemicals and acids are present in the air.
Corrosive chemicals: Acids, alkalines, liquids containing salt
Flammable chemicals: Organic Solvents
- Do not use paint thinner or organic solvents to clean the GP.
- Do not store or operate the LCD display in areas receiving direct sunlight, since the sun's UV rays may cause the LCD display's quality to deteriorate.
- Storing this unit in areas at a temperature lower than is recommended in this manual's specifications may cause the LCD display's liquid to congeal, which may damage the panel. Conversely, if the storage area's temperature becomes higher than the allowed level, the LCD's liquid will become isotropic, causing irreversible damage to the LCD. Therefore, be sure to store the panel only in areas where temperatures are within those specified in this manual.
- After turning the GP OFF, be sure to wait a few seconds before turning it ON again. If the GP started too soon, it may not start up correctly.
- Due to the possibility of unexpected accidents, be sure to back up the GP's screen data regularly.
- Do not connect or disconnect the communication cable to the host machine while the power is ON.

UL/c-UL (CSA) Approval

The GP37W3-BG41-24V is a UL/c-UL (CSA) recognized components.

UL File No. E231702. (UL60950+UL1604)

This unit conforms as a component to the following standards:

■ **UL 1604 and UL 60950 Third Edition**

Safety of Information Technology Equipment for use in Class I and II, Division 2, and Class III Hazardous (classified) locations.

■ **CAN/CSA-C22.2, No.60950-00 and No.213-M1987**

Safety of Information Technology Equipment for use in Class I and II, Division 2, and Class III Hazardous (classified) locations.

GP37W3-BG41-24V (UL Registration Model: 3180038-01)

- The GP must be used as a built-in component of an end-use product.
- Machinery which has a GP installed in it requires UL/c-UL inspection for the combination of this unit and the machinery.
- If the GP is mounted so as to cool itself naturally, be sure to install it in a vertical panel. Also, be sure the unit is installed so that it is at least 100mm (3.94 in.) away from any adjacent structures or devices. If these requirements are not met, the heat generated by the GP's internal components may cause the unit to fail to meet UL/c-UL standard requirements.

UL1604 - Compliance and Handling Cautions

1. Power and input/output wiring must be in accordance with Class I, Division 2 wiring methods - Article 501-4(b) of the National Electrical Code, NFPA 70 within the United States, and in accordance with Section 18-152 of the Canadian Electrical Code for units installed within Canada.
2. Suitable for use in Class I, Division 2, Groups A, B, C, and D Hazardous Locations.
3. WARNING: Explosion hazard - substitution of components may impair compliance to Class I, Division 2.
4. WARNING: Explosion hazard - when in hazardous locations, turn the power OFF before replacing or wiring modules.
5. WARNING: Explosion hazard - confirm that the power supply has been turned OFF before disconnecting equipment, or confirm that the location is not subject to the risk of explosion.

CE Marking

The GP37W3-BG41-24V is CE marked products that conform to EMC directives EN61000-6-4 and EN61000-6-2.

For detailed CE marking information, please contact your local GP distributor.

CNS Application Notes

The GP37W3-BG41-24V complies with the following CNS recognized standard.

■ CNS 13438 (Class A device)

For detailed CNS information, please contact your local GP distributor.

警告使用者：

這是甲類的資訊產品、在居住的環境中使用時、可能會造成射頻干擾、在這種情況下、使用者會被要求採取某些適當的對策。

The GP is an Industrial Device (Class A Device). Use of this device in a home may cause radio wave interference with nearby devices. If interference does occur, please try a variety of countermeasures to solve the problem.

Package Contents

The following items are included in the GP's package. Before using the GP, please confirm that all items shown here are present.

■ GP Unit (1)

(GP37W3-BG41-24V)

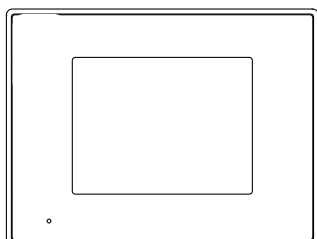

■ Installation Guide (1)



■ Installation Fasteners (4)

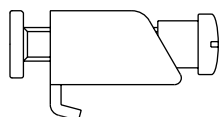

■ Installation Gasket (1)

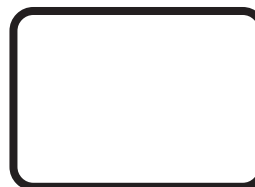

This unit has been carefully packed, with special attention to quality. However, should you find anything damaged or missing, please contact your local GP distributor immediately.

1 Parts Names and Functions

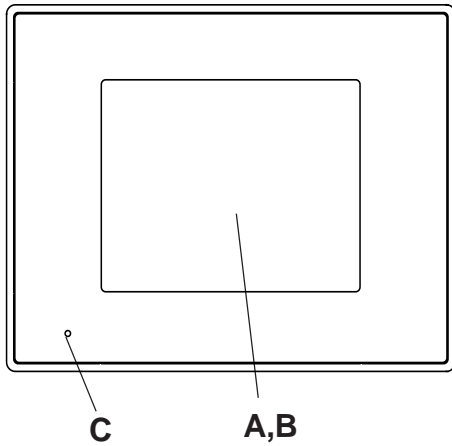

A: Display

Blue mode LCD

Displays User-created screens and host (PLC) data.

B: Touch Panel

Performs screen change operations and sends data to the host (PLC).

C: Power Lamp

Lights when the power cord is connected. (Green LED)

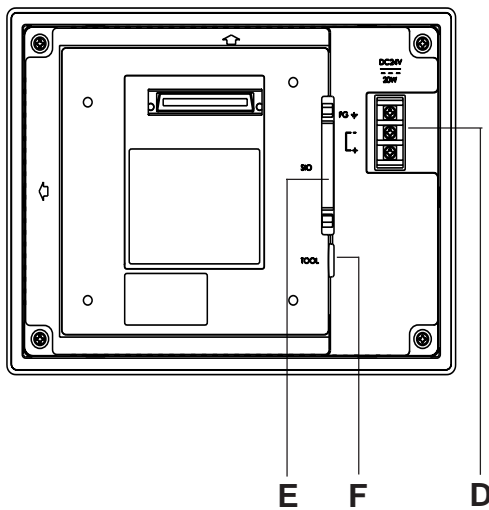

D: Power Input Terminal Block

Connects the GP power cable's input and ground wires to the GP.

E. Serial Interface

Connects an RS-232C or RS-422 (Serial) cable (from the host/PLC) to the GP.

F: Tool Connector

Connects the Data Transfer Cable to the GP.

2 Dimensions

Unit: mm (in.)

Top View

191.2 (7.53)

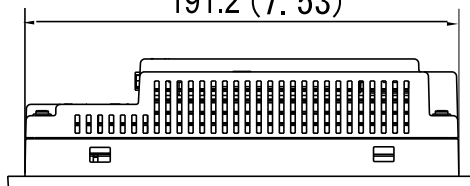

Front View

207 (8.15)

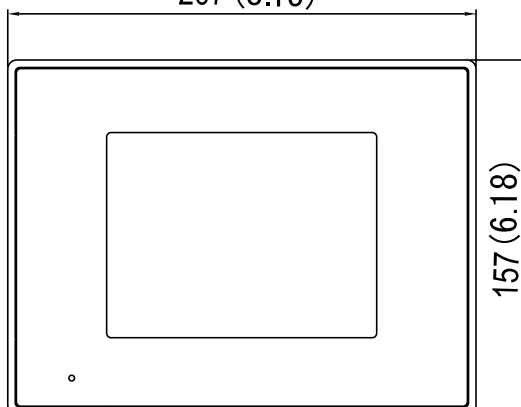

Side View

58 (2.28)

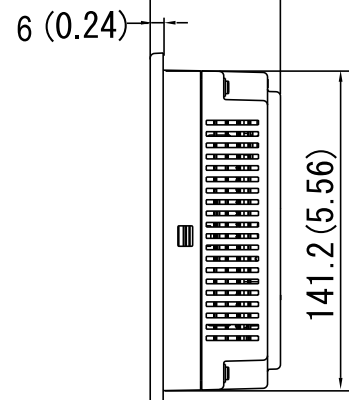

3 Serial Interface

This interface is used to connect the GP to the host (PLC), via either an RS-232C or RS-422 cable.

	Pin #	Signal Name	Meaning
	1	FG	Frame Ground
	2	SD	Send Data (RS-232C)
	3	RD	Receive Data (RS-232C)
	4	RS	Request to Send (RS-232C)
	5	CS	Clear to Send (RS-232C)
	6	NC	No Connection
	7	SG	Signal Ground
	8	CD	Carrier Detect (RS-232C)
	9	TRMX	Termination (RS-422)
	10	RDA	Receive Data A (RS-422)
	11	SDA	Send Data A (RS-422)
	12	NC	No Connection
	13	NC	No Connection
	14	VCC	5V Output 0.25A
	15	SDB	Send Data B (RS-422)
	16	RDB	Receive Data B (RS-422)
	17	NC	No Connection
	18	CSB	Clear to Send B (RS-422)
	19	ERB	Enable Receive B (RS-422)
	20	ER	Enable Receive (RS-232C)
	21	CSA	Clear to Send A (RS-422)
	22	ERA	Enable Receive A (RS-422)
	23	BUZZ GND	External Buzzer Ground
	24	NC	No Connection
	25	BUZZ OUT	External Buzzer Output

- Recommended Connector: Dsub 25 pin plug XM2A-2501 <made by OMRON Corp.>
 Recommended Cover: Dsub 25 pin Cover XM2S-2511 <made by OMRON Corp.>
 Dsub 25 pin Cover XM2S-2521 <made by OMRON Corp.>
 Jack Screw XM2Z-0071 <made by OMRON Corp.>



Note: Use rough metric type M2.6 x 0.45p threads to hold the cable's set (fastening) screws in place.

Recommended Cable: CO-MA-VV-SB5P x 28AWG <made by HITACHI Cable>



- **This GP unit's serial port is not isolated. When the host (PLC) unit is also not isolated, and to reduce the risk of damaging the RS-422 circuit, be sure to connect the #7 SG (Signal Ground) terminal.**
- **Pin #14 (VCC) DC 5V Output is not protected. To prevent damage or unit malfunction, use only the designated level of current.**
- **Inside the GP unit, the SG (Signal Ground) and FG (Frame Ground) terminals are connected to each other.**
- **When connecting an external device to the GP with the SG terminal, ensure that no short-circuit loop is created when you setup the system.**



When making a cable, please be aware of the following:

<For RS-422 >

- **The following pairs of pin numbers must be connected (shorted):**
 - #18(CSB) <-> #19 (ERB)**
 - #21(CSA) <-> #22 (ERA)**
- **Connecting the #9 (TRMX) and #10 (RDA) wires adds a termination resistance of 100Ω between RDA and RDB.**
- **Use a 4-wire cable when the PLC type is Memory Link and the cable is RS-422.**

<For RS-232C >

- **Do not connect #9 (TRMX), #10 (RDA), #11 (SDA), #15 (SDB), #16 (RDB), #18(CSB), #19 (ERB), #21 (CSA), and #22 (ERA).**
- **Connect the #1 (FG) terminal only if it is required by a connected device.**

<External Buzzer Output>

Use pins 23(BUZZ GND) and 25(BUZZ OUT) when producing external output for an alarm.

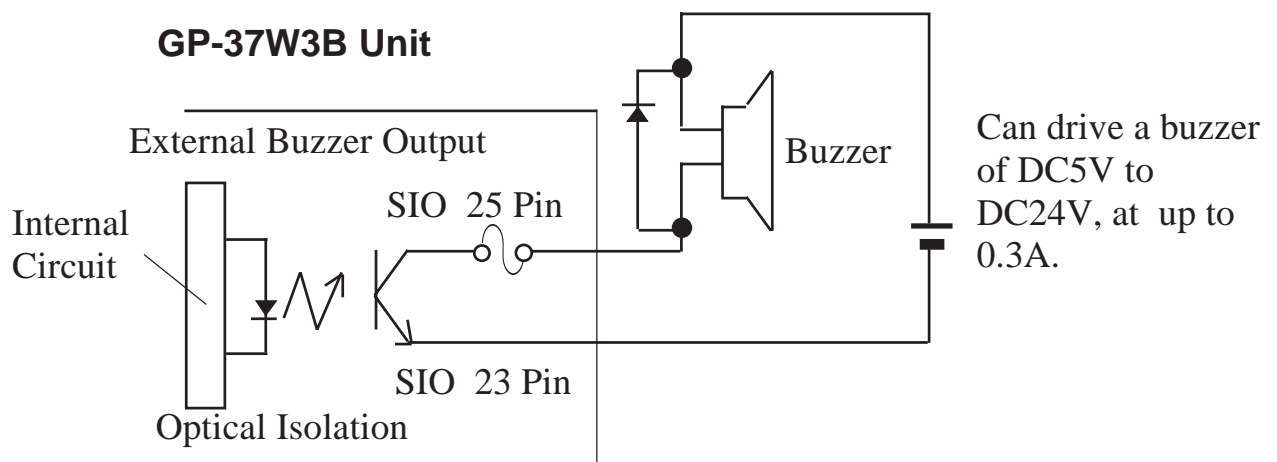

4 Installation

■ Confirm the Installation Gasket's Positioning

It is strongly recommended that you use the gasket since it absorbs vibration in addition to repelling water.



Prior to installing the GP in its metal panel, place the unit on a level surface with the display panel facing downward and check that the installation gasket is securely attached to the back of the unit.

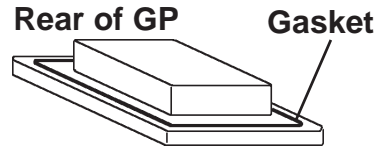

■ Cut a hole in the metal panel according to the dimensions given below

Insert the GP into the panel from the front of the panel.

Unit: mm (in.)

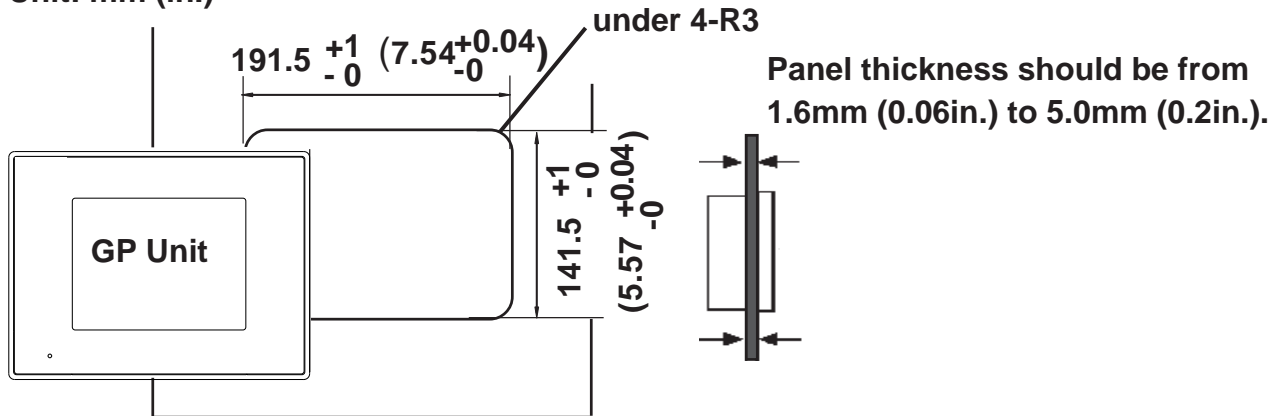

■ Attach the GP's Installation Fasteners from inside the panel

The following figures show the four (4) insertion slot locations of the fasteners. Insert each fastener's hook into the slot and tighten it with a screwdriver.

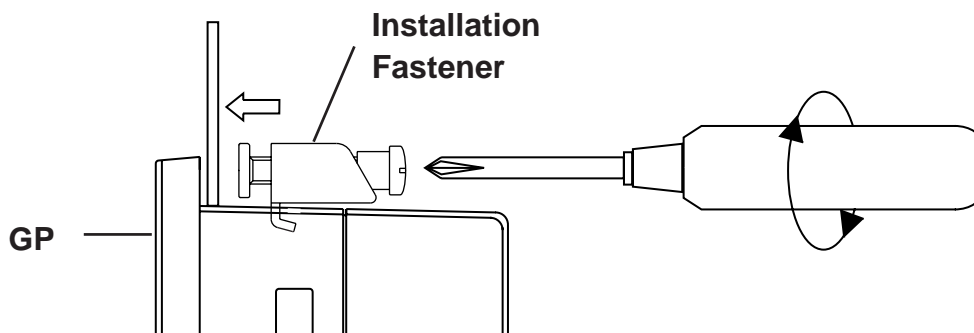

Tightening the fastener screws with too much force can damage the GP's case. The torque necessary to ensure a sufficient seal is 0.5 to 0.6N•m.

5 Wiring

WARNINGS

- To avoid an electric shock, check first that the GP's power supply is completely turned OFF, via a breaker, or similar unit when connecting the GP power cord terminals to the power terminal block.
- GP37W3-BG41-24V is designed to use only DC24V input. Any other power level can damage both the GP and the power supply.
- The GP-37W3B is not equipped with a power switch, therefore, you need to use a breaker switch.



- When connecting a wire to the GP's FG terminal, be sure the wire is grounded. Not grounding the wire will result in excessive noise.
- To avoid a short caused by loose ring terminals, be sure to use ring terminals with an insulating sleeve.



- Wherever possible, use thick wires (max. 2 mm²) for power terminals, and twist the wire ends before attaching the ring terminals.
- Be sure to use the following size ring terminals.*¹

Under 6.0mm (0.24in.) Over ϕ 3.2mm (0.13in.)

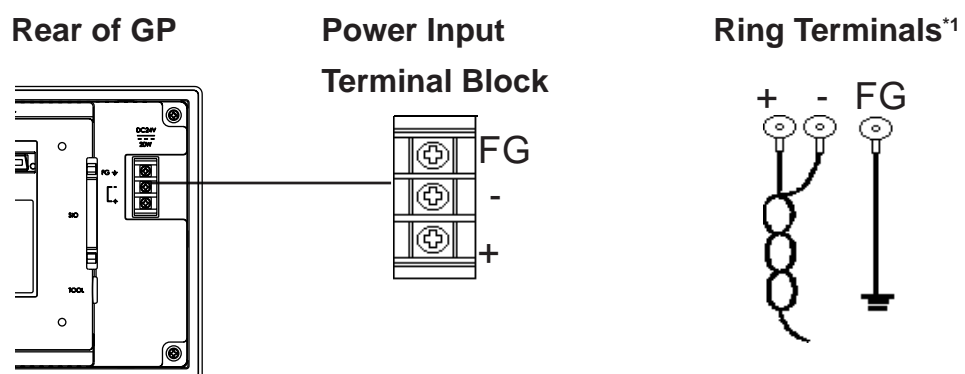
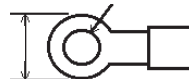

*¹ Suggested Ring Terminal: V2-MS3 (made by JST Co.)

■ Connecting the GP's Power Cord

When connecting the power cord, be sure to follow the procedures given below.

1. Confirm that the GP's Power Cord is unplugged from the power supply.
2. Use a screwdriver to remove the Power Input Terminal Block's clear plastic cover.
3. Unscrew the screws from the middle three (3) terminals, align the Ring Terminals and reattach the screws.
4. Confirm that the wires are connected correctly.
5. Replace the Power Input Terminal Block's clear plastic cover.



The torque required for fastening the screws is 0.5 to 0.6N•m.

6 Grounding Precaution

- When attaching a wire to the GP's rear face FG terminal, (on the Power Input Terminal Block), be sure to create an exclusive ground. ^{*1}
- Inside the GP-37W3B unit, the SG(Signal Ground) and FG(Frame Ground) terminals are connected to each other.
- When connecting an external device to the GP with the SG terminal, ensure that no short-circuit loop is created when you setup the system.

7 Input/Output Signal Line Precautions

- All GP Input and Output signal lines must be separated from all operating circuit (power) cables.
- If this is not possible, use a shielded cable and ground the shield.

8 Maintenance and Inspection

When the surface or the frame of the display gets dirty, soak a soft cloth in water with a neutral detergent, wring the cloth tightly, and wipe the display.



- Do not use paint thinner, organic solvents, or strong acid compound to clean the unit.
- Do not use hard or pointed objects to operate the touch-screen panel, since it can damage the panel surface.

^{*1} Use a grounding resistance of 100Ω, a wire of 2mm² or thicker, or your country's applicable standard.