

Easy! Smooth!
ST-400 Series->GP4000 Series
Replacement Guidebook

Preface

This manual introduces the procedures to replace a unit in ST-400 series (ST-400/401/402/403) with a unit in GP4000 series.

Model in use	Recommended Substitution
ST-400	GP-4201TW
ST-401	
ST-402	GP-4203T
ST-403	GP-4201T

Safety Information

HAZARD OF OPERATOR INJURY, OR UNINTENDED EQUIPMENT DAMAGE

Before operating any of these products, be sure to read all related manuals thoroughly.

Failure to follow these instructions can result in death, serious injury or unintended equipment damage.

GP4000 Series Model Number

GP4000 series model number partly differs depending on a specification. Before placing an order, please make sure of the model number.

PFXGP4 * 0 * * * * *

A

B

C

D

E

F

A	2	GP-4200 series (3.5")
	3	GP-4300 series (5.7")
	4	GP-4400 series (7.5"/7.0"W)
	5	GP-4500 series (10.4")
	6	GP-4600 series (12.1")
B	01	RS-232C/422/485
	03	RS-485 (isolation)
C	T	TFT color LCD
	W	TFT color LCD (Wide Type)
D	A	Analog Resistive Film Touch Panel
	M	Matrix Resistive Film Touch Panel
E	A	AC Type Power Supply
	D	DC Type Power Supply
F	W	GP-4201TW/4301TW/4401WW/4501TW
	C	Coated model
	WC	Coated model of GP-4301TW

Contents

<u>PREFACE</u>	<u>2</u>
<u>SAFETY INFORMATION</u>	<u>2</u>
<u>HAZARD OF OPERATOR INJURY, OR UNINTENDED EQUIPMENT DAMAGE</u>	<u>2</u>
<u>GP4000 SERIES MODEL NUMBER</u>	<u>3</u>
<u>CONTENTS</u>	<u>4</u>
<u>CHAPTER 1 SPECIFICATION COMPARISON</u>	<u>6</u>
1.1 SPECIFICATIONS OF ST-400/401 AND GP-4201TW	6
1.2 SPECIFICATIONS OF ST-402 AND GP-4203T	7
1.3 SPECIFICATIONS OF ST-403 AND GP-4201T	8
<u>CHAPTER 2 COMPATIBILITY OF HARDWARE</u>	<u>9</u>
2.1 LOCATIONS OF CONNECTOR	9
CONNECTOR LOCATIONS ON ST-400/401 AND GP-4201TW	9
CONNECTOR LOCATIONS ON ST402 AND GP-4203T	11
CONNECTOR LOCATIONS ON ST403 AND GP-4201T	12
2.2 TOUCH PANEL SPECIFICATIONS	13
2.3 DISPLAY COLORS	14
2.4 TRANSFER CABLE	15
2.5 FUNCTION SWITCH	15
2.6 INTERFACE	15
2.6.1 SERIAL INTERFACE	15
2.7 PERIPHERAL UNITS AND OPTION UNITS	16
2.7.1 BARCODE READER CONNECTION	16

2.8 POWER CONSUMPTION	17
2.9 MATERIALS/COLORS OF THE BODY	17
2.10 ABOUT PRO-SERVER	17
2.11 OTHER NOTES	17

CHAPTER 3 REPLACEMENT PROCEDURE **18**



3.1 WORK FLOW	18
3.2 PREPARATION	19
3.3 RECEIVE SCREEN DATA FROM ST-400 SERIES	20
3.4 CONVERT SCREEN DATA WITH THE PROJECT CONVERTER	24
3.5 TRANSFER THE SCREEN DATA TO GP4000 SERIES	30
3.6 DIFFERENCES OF SOFTWARE	35
3.6.1 DIFFERENCES AFTER CONVERSION	35

CHAPTER 4 COMMUNICATION WITH DEVICE/PLC **37**



4.1 DRIVERS	37
4.2 SHAPES OF COM PORTS	37
4.3 SIGNALS OF COM PORTS	38
4.3.1 SIGNALS OF COM1	38
4.3.2 SIGNALS OF COM2	42
4.4 MULTILINK CONNECTION	43
4.5 INTERNAL 2-PORT FEATURE FOR MITSUBISHI PLC	43
4.6 CABLE DIAGRAM AT THE TIME OF REPLACEMENT	44

Chapter 1 Specification Comparison



1.1 Specifications of ST-400/401 and GP-4201TW

		ST-400/401	GP-4201TW
			
Display Type		Monochrome LCD	UP! TFT color LCD
Display Colors, Levels		Monochrome, 2 levels/ Monochrome, 8 levels	UP! 65,536 colors (without blink)/ 16,384 colors (with blink) ->See 2.3
Display Resolution		QVGA (320x240 pixels)	
Panel Cutout Dimensions (mm)		118.5(W)x92.5(H)	
External Dimensions (mm)		130(W)x104(H)x41(D)	132(W)x106(H)x42(D)
Touch Panel Type		Resistive film (Matrix)	NEW! Resistive film (Analog) ->See 2.2
Memory	Application	640KB	UP! 8MB
	SRAM	96KB	UP! 128KB
Backup Battery		Secondary Battery (Rechargeable Lithium battery)	
Rated Input Voltage		DC 24V	
Function Switch		✓	-
Serial I/F	COM1	ST-400	D-Sub 9 pin (plug) RS-232C ->See 2.6.1 and Chapter4
		ST-401	
	COM2		
USB I/F	Type A	-	NEW! ✓
	Type mini B	-	->See 2.4
Tool Connector I/F		✓	-

1.2 Specifications of ST-402 and GP-4203T

		ST-402	GP-4203T
			
Display Type		Monochrome LCD	UP! TFT color LCD
Display Colors		Monochrome, 2 levels/ Monochrome, 8 levels	UP! 65,536 colors (without blink)/ 16,384 colors (with blink) ->See 2.3
Display Resolution		QVGA (320x240 pixels)	
Panel Cutout Dimensions (mm)		118.5(W)×92.5(H)	
External Dimensions (mm)		130(W)×104(H)×41(D)	132(W)×106(H)×42(D)
Touch Panel Type		Resistive film (Matrix)	NEW! Resistive film (Analog) ->See 2.2
Memory	Application	640KB	UP! 16MB
	SRAM	96KB	UP! 320KB
Backup Battery		Secondary Battery (Rechargeable Lithium battery)	
Rated Input Voltage		DC 24V	
Function Switch		✓	-
Serial I/F	COM1	D-Sub 9 pin (socket) RS-485 (for MPI only)	D-Sub 9 pin (socket) RS-485 (for MPI only) ->See 2.6.1 and Chapter4
	COM2	D-Sub 9 pin (plug) RS-422	-
Ethernet I/F		-	NEW! 10BASE-T/100BASE-TX
USB I/F	Type A	-	NEW! ✓
	Type mini B		->See 2.4
Tool Connector I/F		✓	-

1.3 Specifications of ST-403 and GP-4201T

		ST-403	GP-4201T
			
Display Type		Monochrome LCD	UP! TFT color LCD
Display Colors		Monochrome, 2 levels/ Monochrome, 8 levels	UP! 65,536 colors (without blink)/ 16,384 colors (with blink) ->See 2.3
Display Resolution		QVGA (320x240 pixels)	
Panel Cutout Dimensions (mm)		118.5(W)x92.5(H)	
External Dimensions (mm)		130(W)x104(H)x41(D)	132(W)x106(H)x42(D)
Touch Panel Type		Resistive film (Matrix)	NEW! Resistive film (Analog) ->See 2.2
Memory	Application	640KB	UP! 16MB
	SRAM	96KB	UP! 320KB
Backup Battery		Secondary Battery (Rechargeable Lithium battery)	
Rated Input Voltage		DC 24V	
Function Switch		✓	-
Serial I/F	COM1	D-Sub 9 pin (plug) RS-232C/422	D-Sub 9 pin (plug) RS-232C/422/485 ->See 2.6.1 and Chapter4
Ethernet I/F		10BASE-T	NEW! 10BASE-T/100BASE-TX
USB I/F	Type A	-	NEW! ✓
	Type mini B		->See 2.4
Tool Connector I/F		-	

Chapter 2 Compatibility of Hardware

2.1 Locations of connector

Connector locations on ST-400 series and GP4000 series are as follows:

Connector locations on ST-400/401 and GP-4201TW

ST-400/401

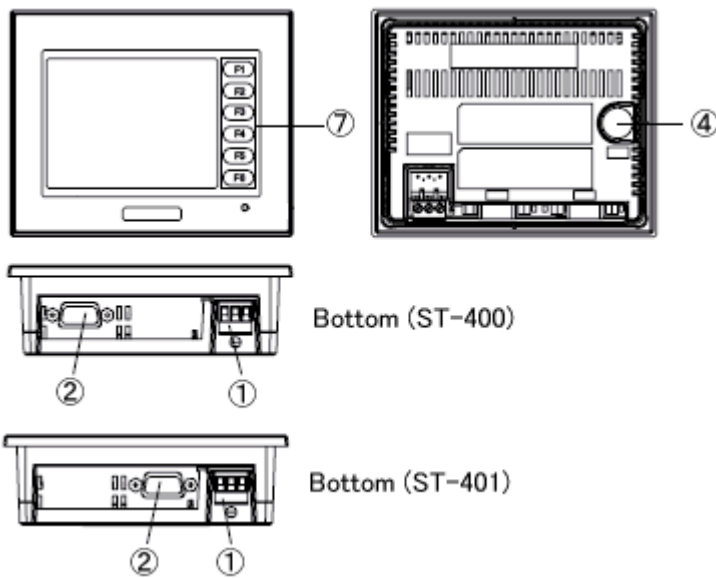

GP-4201TW

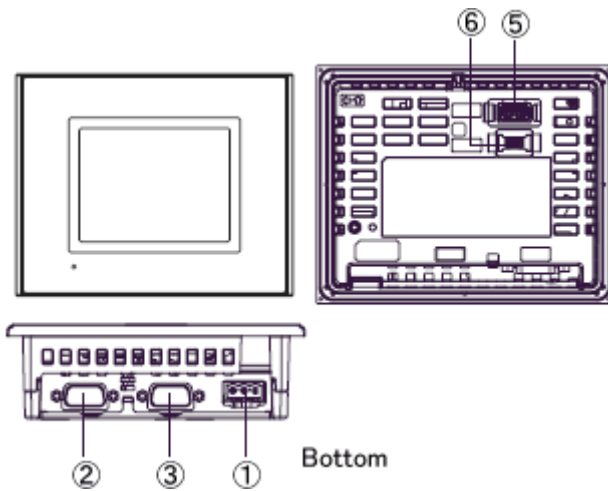

Interface names

	ST-400/401	GP-4201TW
1	Power Connector	
2	Serial Interface (COM1)	
3	-	Serial Interface (COM2)
4	Tool Connector	-
5	-	USB Interface (Type A)
6	-	USB Interface (Type mini B)
7	Function Switch	-

Connector locations on ST402 and GP-4203T

ST-402

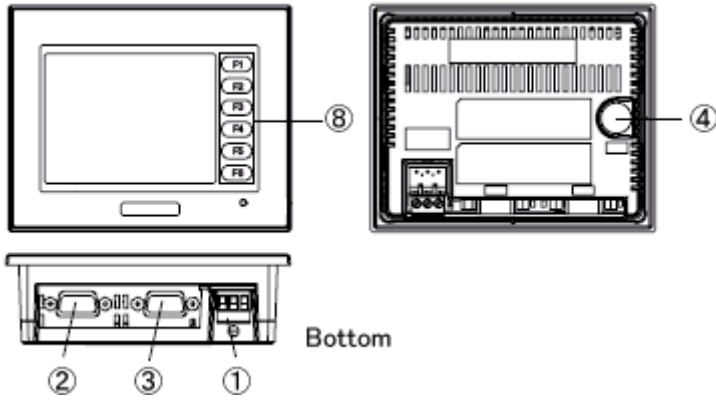

GP-4203T

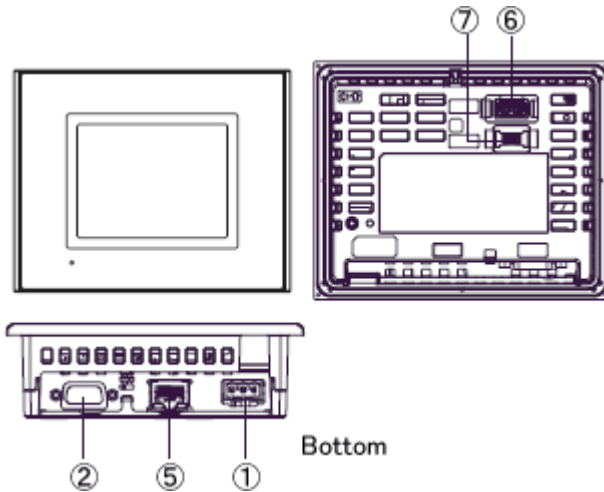

Interface names

	ST-402	GP-4203T
1	Power Connector	
2	Serial Interface (COM1)	
3	Serial Interface (COM2)	-
4	Tool Connector	-
5	-	Ethernet Interface
6	-	USB Interface (Type A)
7	-	USB Interface (Type mini B)
8	Function Switch	-

Connector locations on ST403 and GP-4201T

ST403

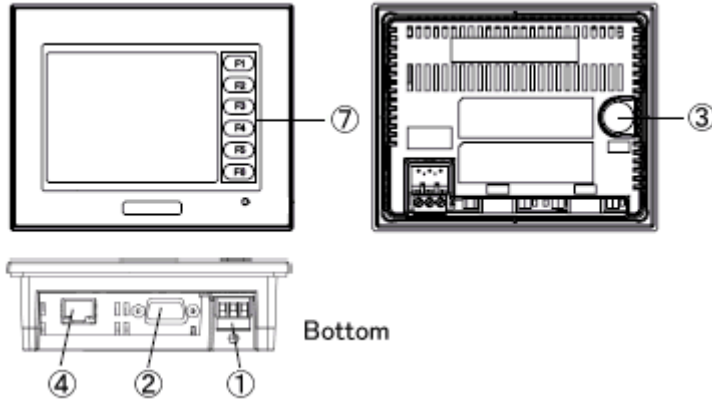

GP-4201T

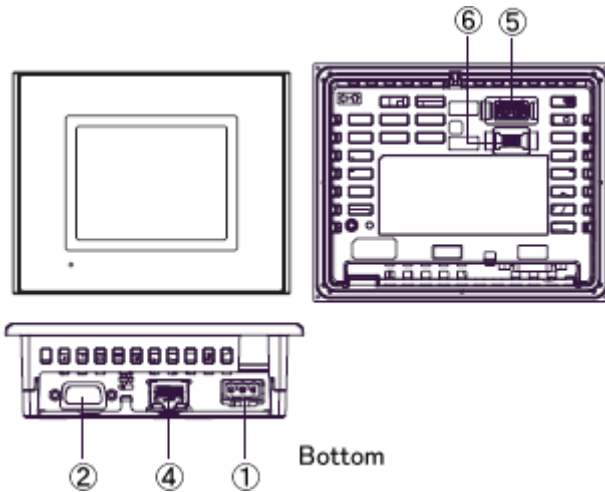

Interface names

	ST403	GP-4201T
1	Power Connector	
2	Serial Interface (COM1)	
3	Tool Connector	-
4	-	Ethernet Interface
5	-	USB Interface (Type A)
6	-	USB Interface (Type mini B)
7	Function Switch	-

2.2 Touch Panel specifications

GP-420xT/4201TW adopts the Analog type. Because of it, simultaneous 2-point touch input operation is not supported. When simultaneous 2-point touch input operation is performed, GP's operation is as described below.

GP-420xT: Only the first detected touch is effective.

GP-4201TW: When two different points are pushed at the same time, touch input on the middle coordinates between those two points is recognized.

If you have used the 2-point touch input on GP-2300 series, change to the 1-point touch input setting using the switch delay function of GP-Pro EX.

2.3 Display Colors

The display color of ST-400 series is monochrome, but GP4000 series has a TFT color LCD. After replacement, the display color changes from monochrome to color.

When data of a monochrome model is converted to data of a color model with GP-Pro EX, the data may be displayed in colors depending on the version of the Project Converter or settings of the drawing/the parts on the screen.

After conversion, please confirm the display colors of the drawing or the parts on the screens just in case.

If the display is in colors after the data conversion to GP4000 series...

GP-Pro EX Ver. 3.01.200 (Service Pack1) or later supports the function which changes drawing in colors to in monochrome. To change the setting, follow the steps below.

- (1) Click [Project]->[System Settings]->[Display Unit].
- (2) Open the [Display Settings] tab.
- (3) Change [Color] setting to "16 Levels Monochrome, 3-Speed Blink".
- (4) Select [Yellow/Black].

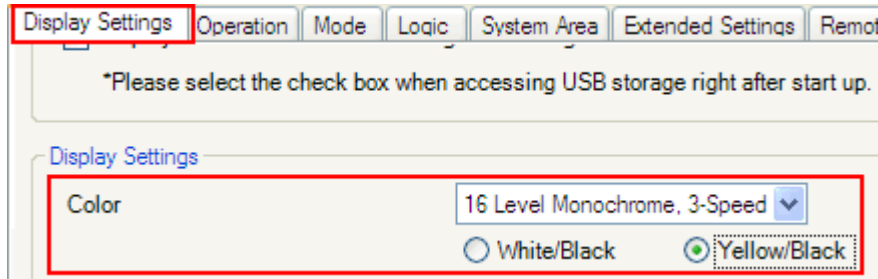



* [Reverse Display] setting is for displaying the screen with black/white reversed. Check on it if needed.



* Please confirm the display colors of the drawing or the parts on the screens after changing the [Color] setting to "16 Levels Monochrome, 3-Speed Blink".

2.4 Transfer cable

To transfer screen data to GP4000 series, use an USB transfer cable or Ethernet. The USB cables that can be used for GP4000 series are as follows:

	Model	Connector Type	Connector on GP
Options	CA3-USBCB-01	 Type A Type A	USB (Type A)
	ZC9USCBMB1	 Type A Type mini B	USB (Type mini B)
Commercial Item	-		

Please note that the cables (GPW-CB02, GPW-CB03, GP430-CU02-M) for ST-400 series cannot be used for GP4000 series.

2.5 Function Switch

GP4000 series does not have function switches. If you use the functions of the function switches specified on ST-400 series, please make settings of the switches to replace the function keys on GP-ProEX.

2.6 Interface

2.6.1 Serial Interface

The pin assignment and the shape of plug/socket connector of ST-400 series are different from those of GP4000 series.

To know the details about them, see [[4.2 Shapes of COM ports](#)] and [[4.3 Signals of COM ports](#)].

Because of it, the existing PLC connection cables cannot be used as they are. If you

use the existing connection cables, see [[4.6 Cable Diagram at the time of replacement](#)].

* For ST-402 users only:

If ST-402 is connected to a RS-422 device via its COM2 port, after ST-402 is replaced with GP-4203, the device cannot be connected.

Using a **USB/RS-422/485 Conversion Adapter (PFXZCBCBCVUSR41)** allows you to use GP-4203 USB interface as RS-422/485 serial interface for connection.

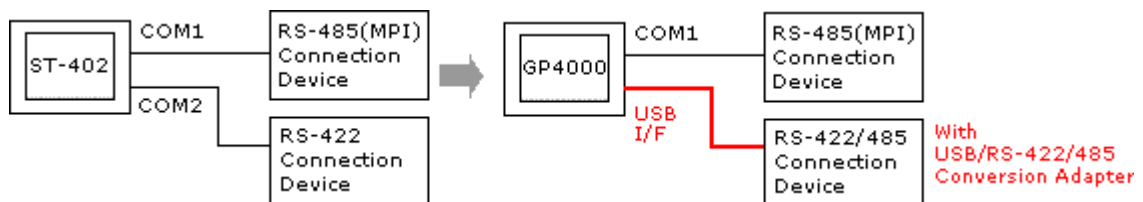

For more information, please refer to USB/RS-422/485 Conversion Adapter Installation Guide.

(<http://www.pro-face.com/otasuke/download/manual/cgi/manual.cgi?mode=33&cat=3>)

IMPORTANT

When using USB/RS-422/485 Conversion Adapter (PFXZCBCBCVUSR41) with a display unit, the device/PLCs you can connect to its serial interface (RS-422/485) are limited. To check the connection configuration, please refer to GP-Pro EX Device/PLC Connection Manual.

(<http://www.pro-face.com/otasuke/files/manual/gpproex/new/device/index.htm>)

If it's not possible to use USB/RS-422/485 Conversion Adapter (PFXZCBCBCVUSR41) for your connection, please contact our sales office in your region. (<http://www.pro-face.com/customer/contact.html>)

2.7 Peripheral units and option units

2.7.1 Barcode reader connection

GP4000 series is not equipped with a tool port. A barcode reader that used to be connected to the tool port on ST-400 series cannot be used. However, GP4000

series allows you to connect a barcode reader on its USB interface (Type A) or its serial interface.

For the models GP4000 series supports, see [OtasukePro!]

(http://www.pro-face.com/otasuke/qa/3000/0056_connect_e.html).

2.8 Power Consumption

The power consumption of ST-400 series is different from that of GP4000 series.

ST-400 series	GP4000 Series
7W or less	9.6W or less

For the detailed electric specifications, see the hardware manual.

2.9 Materials/Colors of the body

The material and the colors of ST-400 series and GP4000 series are as follows:

	ST-400 series	GP4000 Series
Color	Light Gray	
Material	Resin	Resin with glass

2.10 About Pro-Server

If the Pro-Server with Pro-Studio is used for ST403, please use the Pro-Server EX Ver.1.30 or later. For details of the installation, refer to the

http://www.pro-face.com/otasuke/qa/server_ex/replace/.

2.11 Other Notes

- Do not expose GP4000 series to direct sunlight.
- Do not use GP4000 series outdoors.
- Do not turn on GP4000 series if condensation has occurred inside the device.
- When you are continuously using GP4000 series without oxygen, the brightness might decrease. Please ventilate the control panel periodically.

Chapter 3 Replacement Procedure

3.1 Work Flow

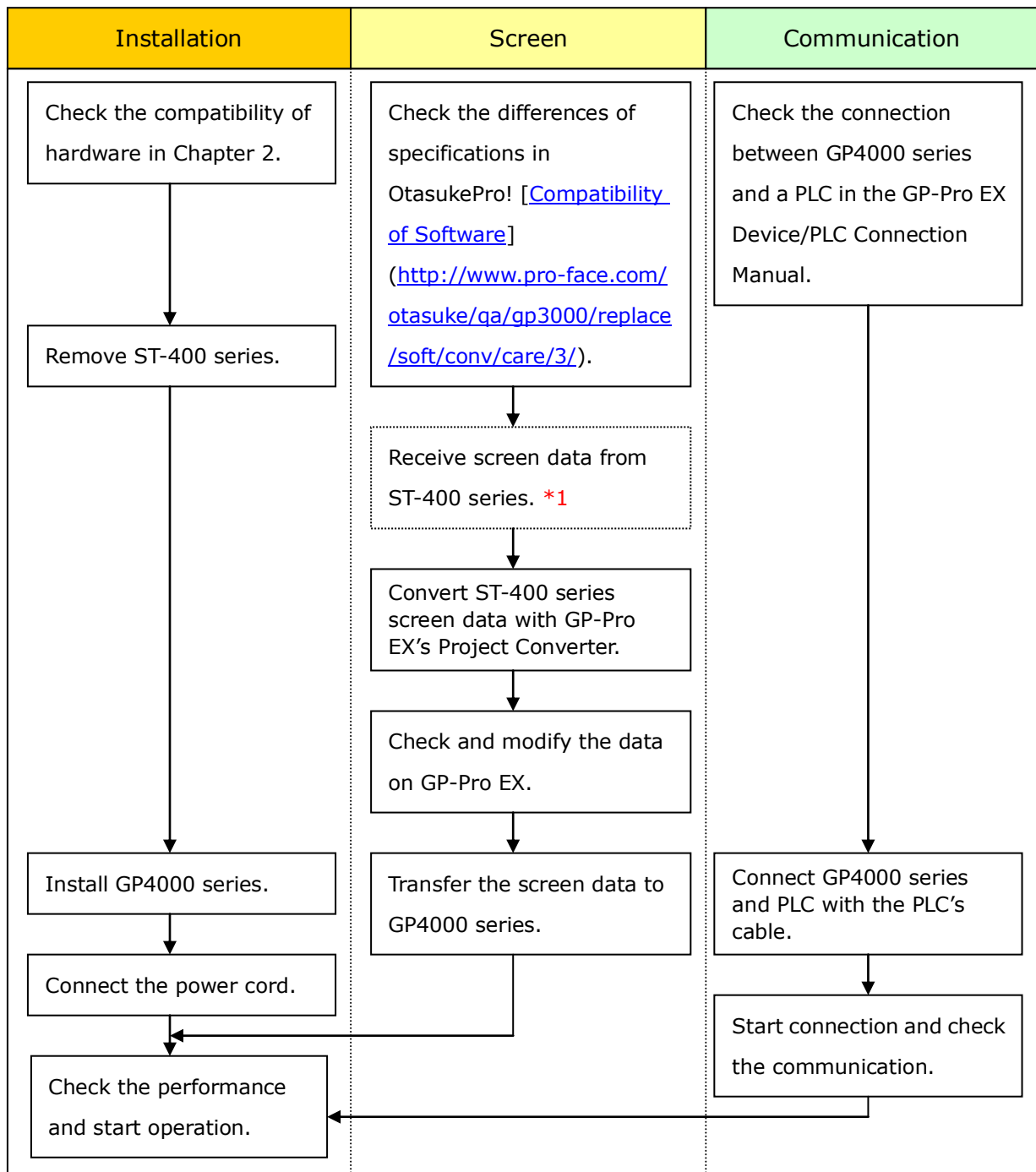

*1: This step is required if screen data is saved only in the GP unit, not in any other device.

3.2 Preparation

Requirements for receiving screen data from ST-400 series *1	ST-400/401/402: PC in which GP-PRO/PBIII for Windows C-Package02 V6.3 or later is installed. *2 ST-403: PC in which GP-PRO/PBIII for Windows C-Package03 V7.2 or later is installed *2
	Transfer cable (The following three types of cables are available) <ul style="list-style-type: none"> • GPW-CB02 (D-sub 9-pin to the PC) • GPW-CB03 (USB to the PC) *3 • GP430-CU02-M or GPW-SET (D-sub 25-pin to the PC) * Also, it's possible for ST-403 to send/receive data via Ethernet.
Requirements for converting screen data of ST-400 series and transferring the converted data to GP4000 series	PC in which GP-Pro EX Ver.3.01 or later is installed
	Transfer cable (The following three types of cables are available) <ul style="list-style-type: none"> • A USB transfer cable (model: CA3-USBCB-01) • A USB data transfer cable (model: ZC9USCBMB1) • A commercial USB cable (USB Type A/mini B) * Possible to send/receive a screen with an USB storage device or via Ethernet.

***1:** This step is required if screen data is saved only in the GP unit, not in any other device

***2:** Please use the same version or later as or than that of the software used during creating screens on GP2000 series.

If you don't know the version, we recommend you to use the newest version. The newest version is GP-PRO/PBIII for Windows C-Package03 (SP2) V7.29. Those who have GP-PRO/PBIII for Windows C-Package03 V7.0 can download it from our web site called [OtasukePro!]

(<http://www.pro-face.com/otasuke/download/update/>).

***3:** GPW-CB03 is supported by GP-PRO/PBIII for Windows C-Package02 (SP2) V6.23 or later. You need to install a driver from [Download] on our Web site called [OtasukePro!]

(<http://www.pro-face.com/otasuke/download/driver/>)

3.3 Receive screen data from ST-400 series

This section explains, as an example, how to receive screen data from ST-400 series using a transfer cable, GPW-CB02 or GPW-CB03. If you have backed up screen data, this step is unnecessary; skip to the next section [[3.4 Convert screen data with the Project Converter](#)].

(1) Connect a transfer cable to a unit in ST-400 series.

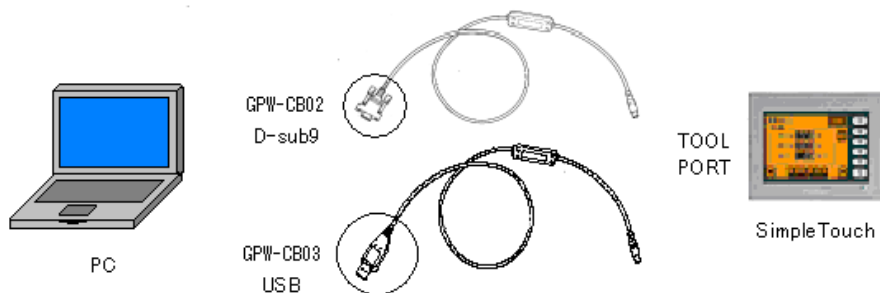

(2) Start up GP-PRO/PBIII for Windows and click the [Transfer] icon on the Project Manager (Specify a desired project file.)



(3) On the [Transfer] window, select the [Setup] menu and click [Transfer Settings...].

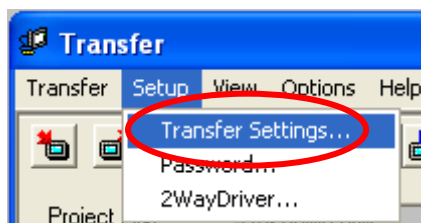

(4) In the Communication Port field, select [COM], specify the COM port to which the cable is connected, and click [OK].

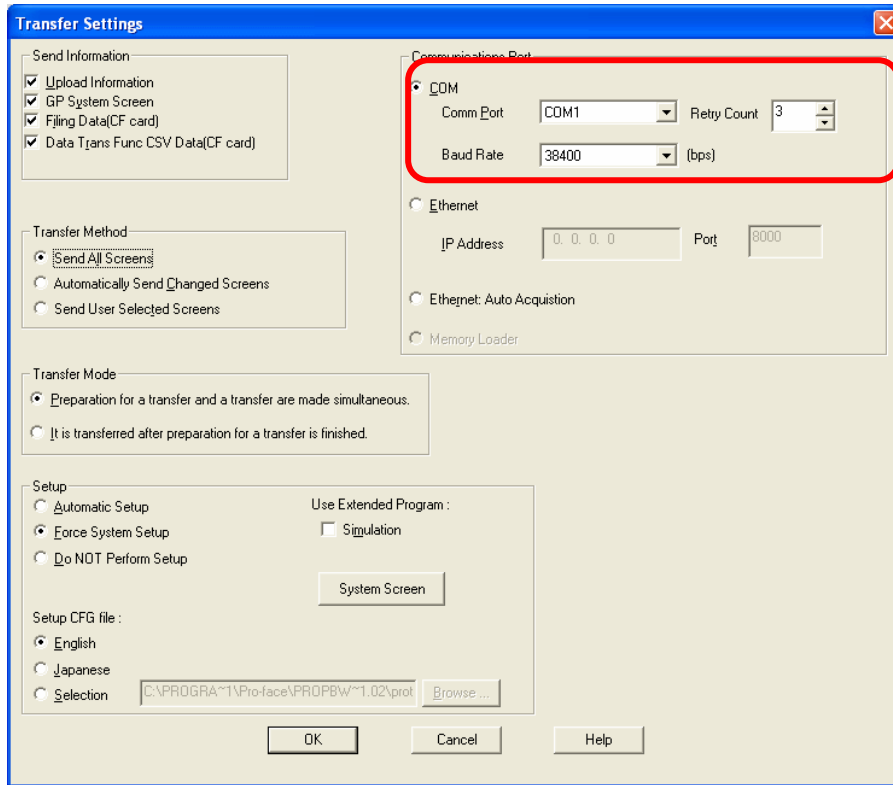

If you use a USB transfer cable (GPW-CB03)

You can check the COM port for the USB transfer cable (GPW-CB03), which is assigned to the PC, with the Device Manager of Windows.

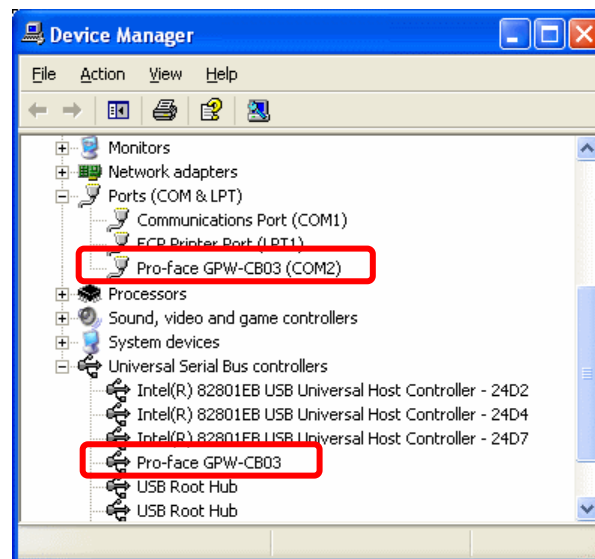

(5) Select the [Transfer] menu and click [Receive...].

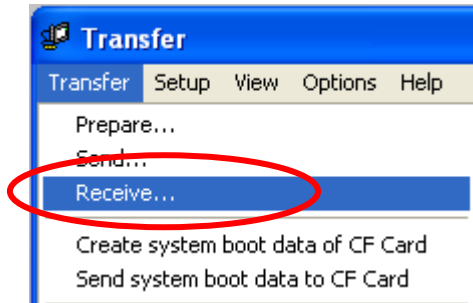

(6) Specify the location to save the received screen data at and the project file name and save them.

In case there is no Upload Information

“Upload Information” is necessary to receive screen data from ST-400 series. It needs to be included in screen data when transferring screen data to the display unit beforehand. The Upload Information is sent to the display unit by default, however, you may check off the box of Upload Information to prevent screen reception by a third party.

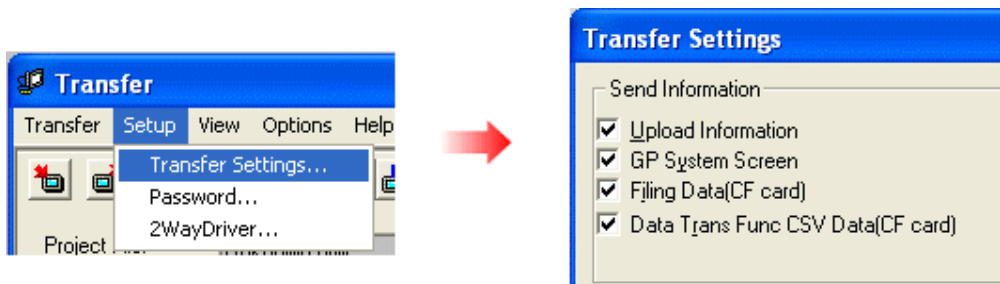

You can check in the following way if the Upload Information has been sent or not.

1. Enter into the GP's Offline mode
2. If there are 2 asterisk (*) marks in the Main menu as shown below, the Upload Information has been sent.

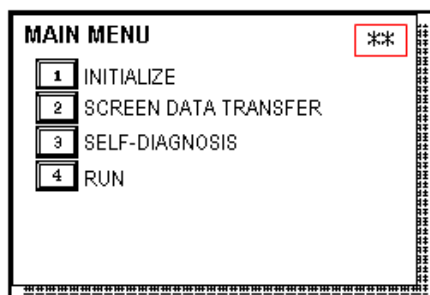

If not, there is no Upload Information sent. In this case, a message, which indicates there is no Upload Information, appears and you cannot receive the data.

3.4 Convert screen data with the Project Converter

Convert a project file (*.prw) for ST-400 series with the GP-Pro EX's Project Converter.

- (1) Click the [Start] button, select [All Programs] (or [Programs])-> [Pro-face]-> [GP-Pro EX *.**]->[Project Converter].

(For this part, [*.**], the version of the software you use is displayed.)

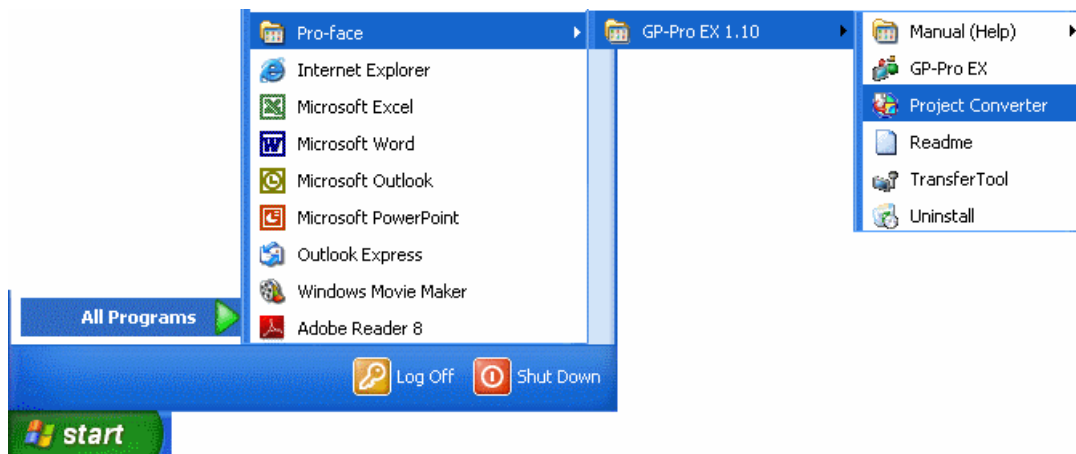

- (2) The Project Converter starts up and the [Project Converter] dialog box opens. Select [Project File (*.PRW)] in the [Data Type].

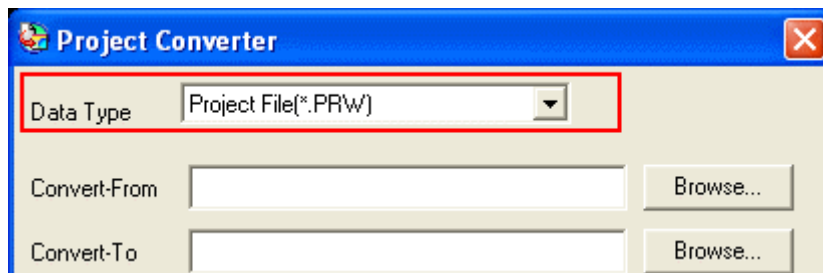

- (3) Click the [Browse...] button and select a project file (e.g.: "Project system A.prw"). Click [Open], and the file will be set in [Convert-From].

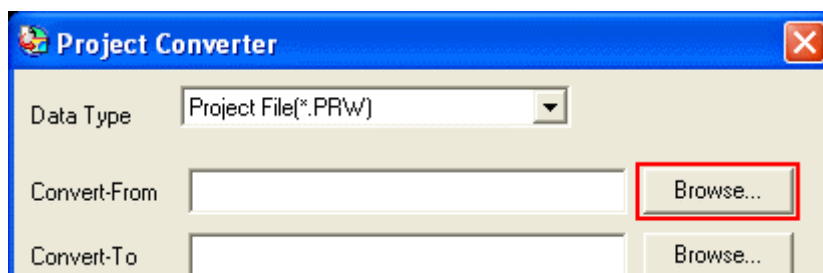

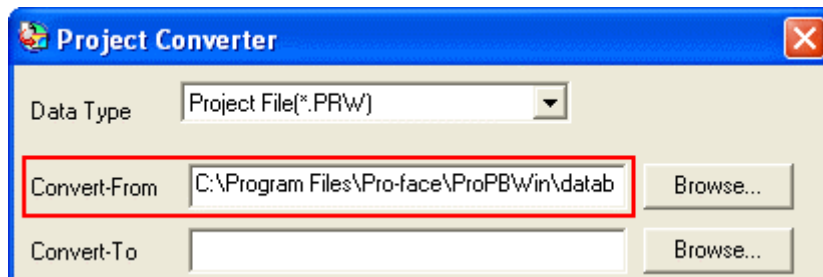
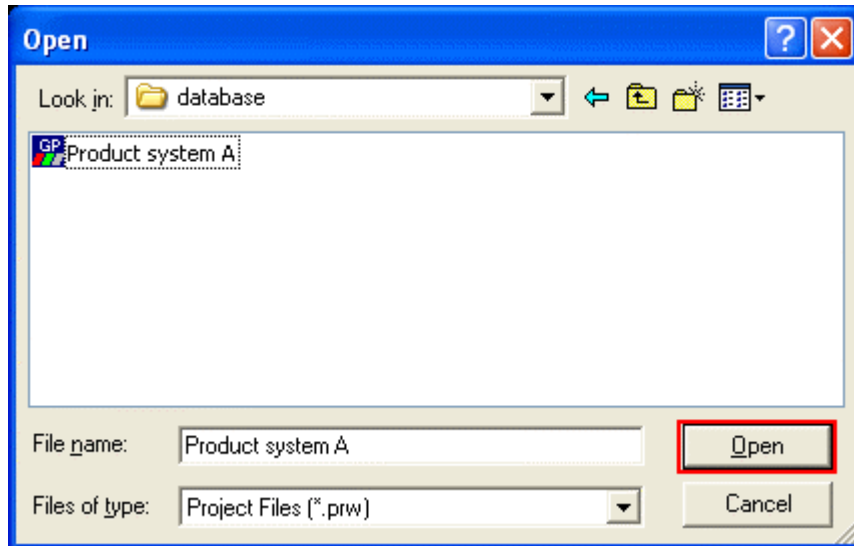

(4) In [Convert-To], designate a GP-Pro EX's project file (*.prx). Click the [Browse...] button and enter a new [File Name] (e.g.: "Product system A.prx"). Click [Save], and a new project file will be set to [Convert-To].

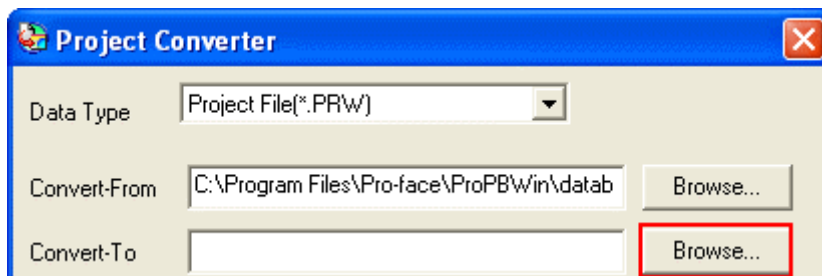

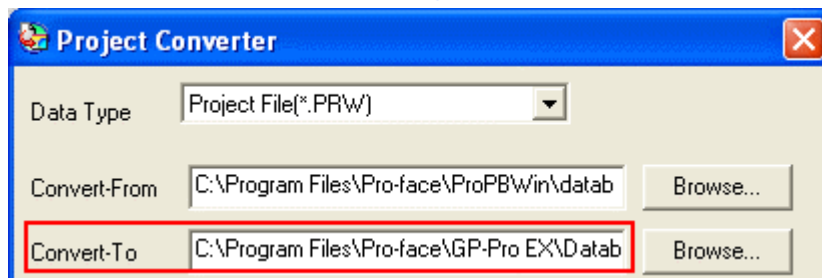
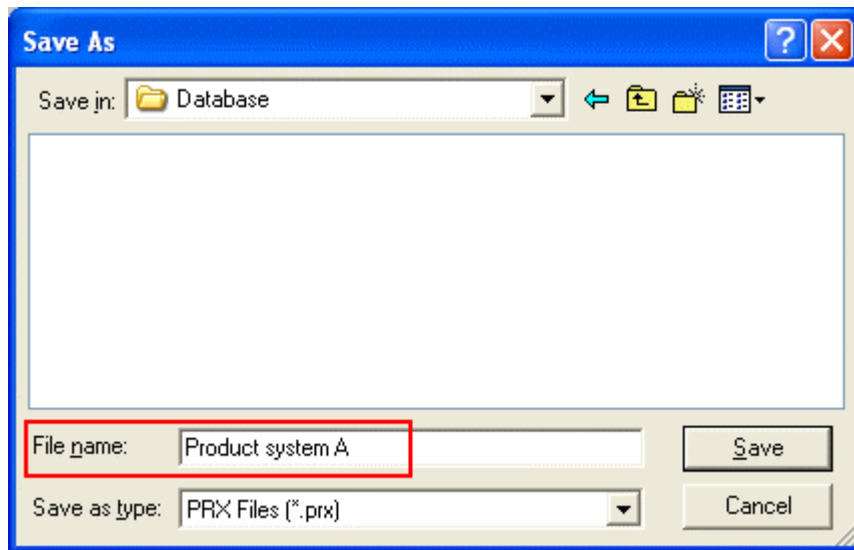

NOTE

When a convert-to file exists, the window that confirms whether or not to overwrite the file is displayed.

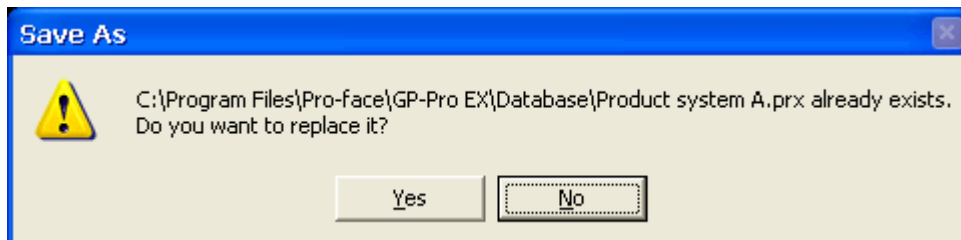

(5) Click [Convert] and start the conversion.

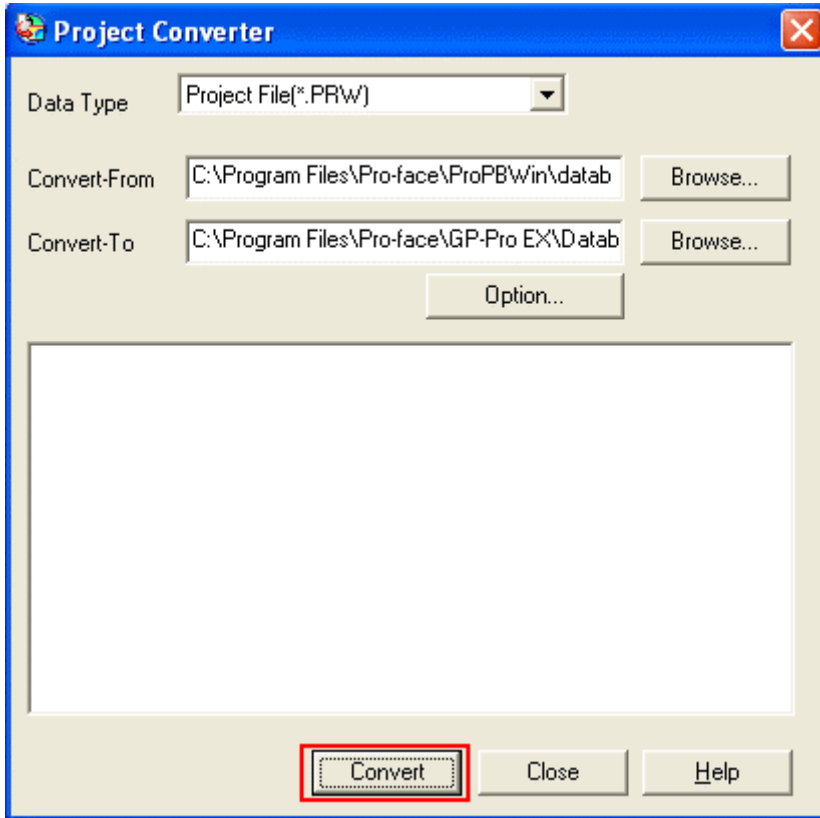

(6) If you are asked about the [Convert-To] type as shown below, select [GP-4501TW] on the pull-down menu. Click [OK].

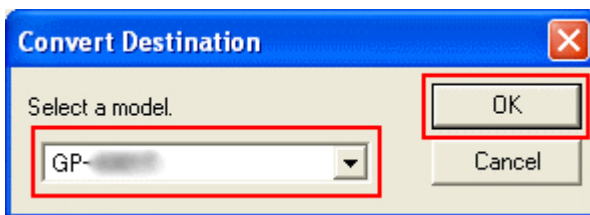

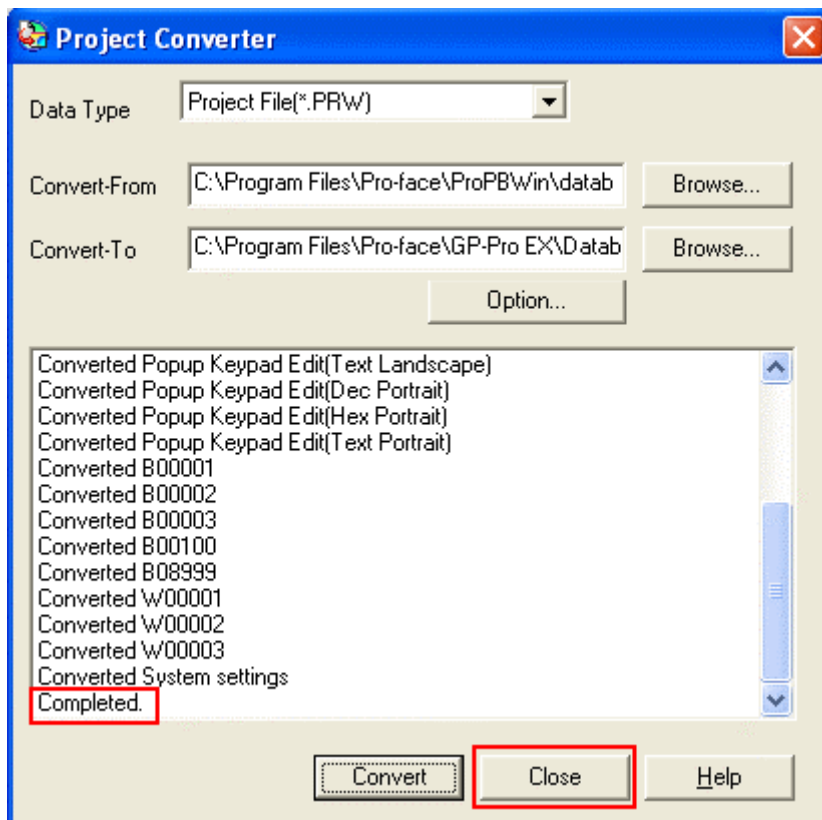

If an error message is displayed during conversion...

If an error message is displayed during conversion, refer to [[Project Converter Error Message](#)] (http://www.pro-face.com/otasuke/qa/gp3000/replace/soft/conv/project_converter_error.html) on our Web site called [OtasukePro!] for the cause and the solution.

(7) After conversion, the [Save convert information] dialog box appears. If you click [Save], you can save the conversion information in a CSV file format.

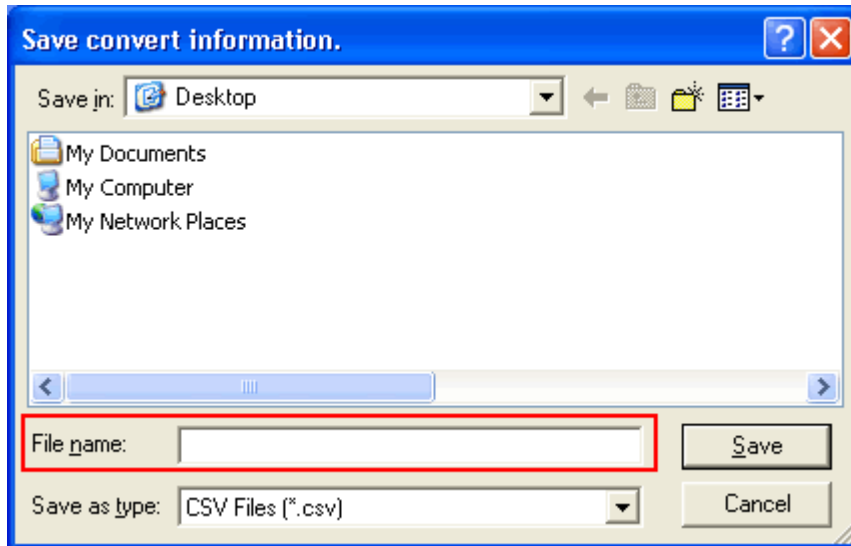

NOTE

Because the differences made at the time of conversion from GP-Pro/PBIII for Windows are described in the saved file, the project file (*.prx) after conversion can be checked and modified according to the conversion information.

(8) Click [Close] to close the [Project Converter] dialog box.

If you double click the project file (*.prx) after conversion, GP-Pro EX will start and the file will open.

3.5 Transfer the screen data to GP4000 series

Transfer the project file after conversion to GP4000 series.

You can transfer data to GP4000 series via

- An USB transfer cable (model: CA3-USBCB-01)
- An USB data transfer cable (model: ZC9USCBMB1)
- A commercial USB cable (USB Type A/mini B)
- An USB storage device
- Ethernet (*for GP-4201T/4203T only)

But, this section explains, as an example, how to transfer screen data with an USB transfer cable (model: CA3-USBCB-01).



PC



USB transfer cable
(CA3-USBCB-01)



GP

(1) Connect your PC and GP4000 series with a USB transfer cable (model: CA3-USBCB-01).

If the driver of the cable has not been installed on you PC yet, a dialog box will appear. Please follow the instructions.

NOTE

- The "Hardware Installation" dialog box as shown below may appear during installing the USB driver depending on the security level of Windows® XP. Click [Continue Anyway] to start installing the driver. When installation is completed, click [Finish].

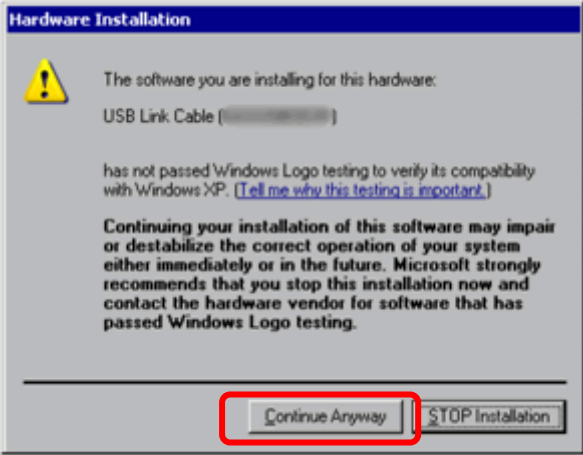

- If the following symptoms appear on Microsoft Windows® 7, go to updating "USB Data Transfer Driver" on [OtasukePro!] for download (http://www.pro-face.com/otasuke/download/freesoft/gproex_transfer.htm).
- An error occurs when GP-Pro EX or Transfer Tool is installed
- An error occurs when data is transferred via a USB transfer cable (model: CA3-USBCB-01).

- (2) Turn on the power of GP4000 series. The "Initial Start Mode" screen will appear on the display unit. After transferring a project file once, this screen will not appear again.



- (3) On the GP-Pro EX's State Toolbar, click the [Transfer Project] icon to open the Transfer Tool.

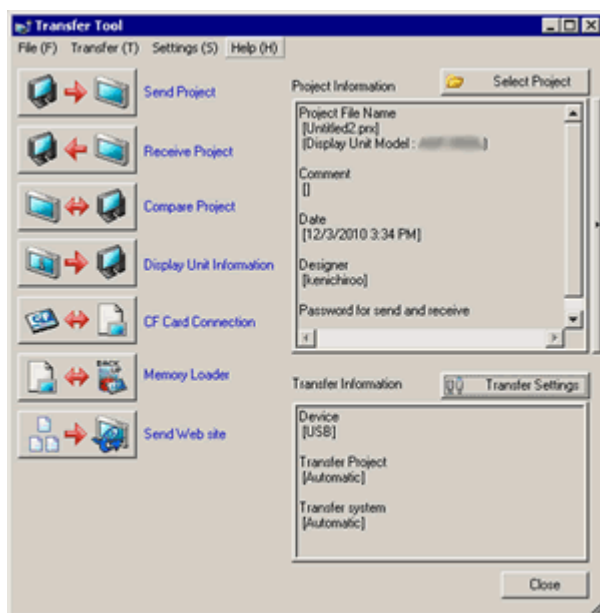

On the GP-Pro EX's State Toolbar, click the [Transfer Project] icon to open the Transfer Tool.

- (4) Make sure that the [Device] in the "Transfer Settings Information" is set to [USB]. If not, click the [Transfer Setting] button to open the "Transfer Setting" dialog box. Select [USB] in the Communication Port Settings field and click [OK].



- (5) Click [Send Project] to start transfer. When the following dialog box appears, click [Yes]. This dialog box doesn't appear when the same project file is sent again.

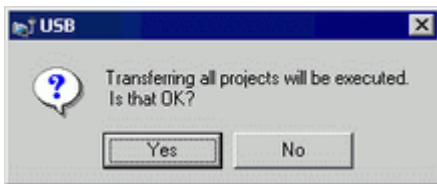

- (6) The following dialog box appears during transfer and you can check the communication status. (The display unit enters the Transferring mode and communication with the device such as a PLC is terminated.)

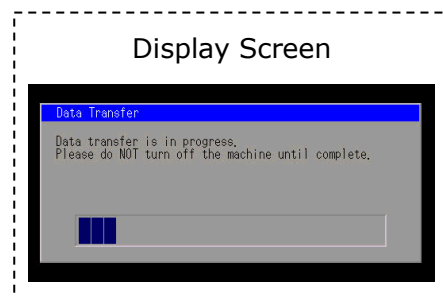
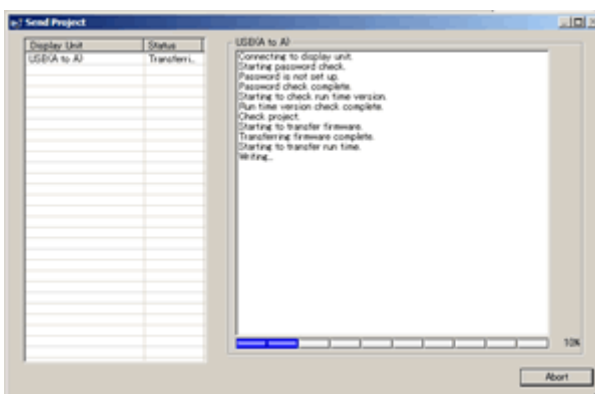

- (7) When transfer is completed, the status displayed in the dialog box will change from [Transferring] to [Complete Transfer]. Click [Close] to close the dialog box.

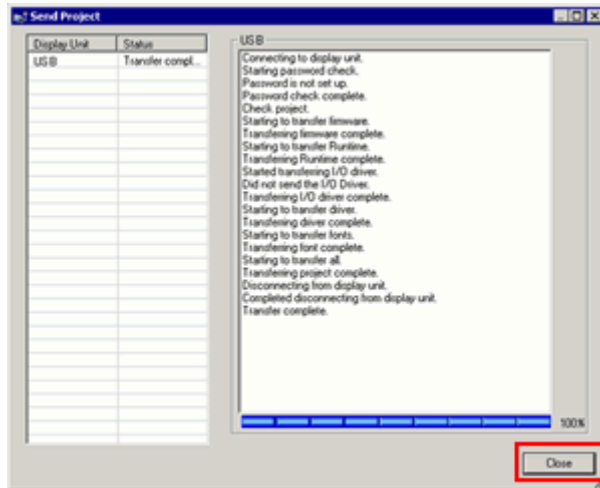

The display unit will be reset and a screen of the transferred project file will be displayed.

- (8) Close the Transfer Tool.
- (9) Click the [X] mark on top right of the screen or [Project]->[Exit] to close GP-Pro EX.

3.6 Differences of software

3.6.1 Differences after conversion

Check the differences of screen data after conversion from GP-PRO/PBIII to GP-Pro EX. For the details of each item, refer to our website.

<http://www.pro-face.com/otasuke/qa/gp3000/replace/soft/conv/care/3/>

Differences of Software

1	Touch Panel Type
2	Compatibility of Bit Switch
3	Compatibility of Alarm
4	Compatibility of Trend Graph
5	Compatibility of K tag (Input Order)
6	Compatibility of K tag (difference of Writing)
7	Compatibility of K tag (Indirect Setting)
8	Compatibility of N tag
9	Precautions for using the switch for [History Data Display] of Trend Graph on the window
10	About window display on a momentary switch during momentary operation
11	About the performance when a display area of the system window is overlapping
12	Change of Tag Process
13	About the display when a fixed Draw is placed on a Part
14	Compatibility of Text
15	Compatibility of Fill
16	Compatibility of CF Card Data
17	Precautions for conversion when filing data is saved in a CF card
18	Precautions for setting "Color Settings" to [256 Colors without blinking]
19	Precautions for loading a part with "L Tag (Library Display)"
20	Compatibility of MRK files and CPW files
21	Compatibility of V Tag/v tag and Video Screen
22	Compatibility of Extended SIO Script
23	Compatibility of Sound Data
24	Compatibility of Device Monitor

25	Compatibility of Ladder Monitor
26	Compatibility of J Tag and R Tag
27	Converting Screen Data of DOS
28	Compatibility of Standard Font
29	D Script starts right after screen change or power on. (Compatibility of D Script Trigger Condition)
30	The position shifts when loading a window screen (Compatibility of U Tag)
31	Precautions for using Screen Level Change
32	Compatibility of H tag

Chapter 4 Communication with Device/PLC

4.1 Drivers

More connectable drivers will be added.

For the devices/PLC each driver supports, see [Connectable Devices]

(<http://www.pro-face.com/product/soft/gpproex/driver/driver.html>).

4.2 Shapes of COM ports

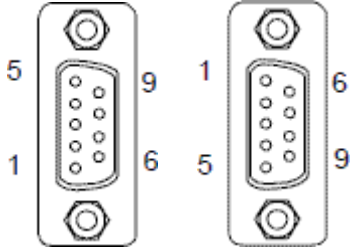
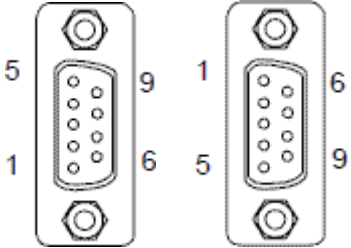
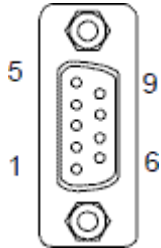
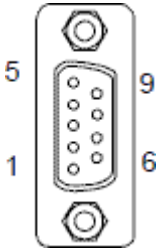
	ST-400 series	GP4000 series																		
COM1	D-Sub 9-pin	D-Sub9-pin																		
	 <p>plug socket</p> <table border="1"> <tr> <td>ST-400</td> <td>RS-422</td> <td rowspan="2">plug</td> </tr> <tr> <td>ST-401</td> <td>RS-232C</td> </tr> <tr> <td>ST-402</td> <td>RS-485 (for MPI)</td> <td>socket</td> </tr> <tr> <td>ST-403</td> <td>RS-232C/ 422</td> <td>plug</td> </tr> </table>	ST-400	RS-422	plug	ST-401	RS-232C	ST-402	RS-485 (for MPI)	socket	ST-403	RS-232C/ 422	plug	 <p>plug socket</p> <table border="1"> <tr> <td>GP-4201T</td> <td>RS-232C/ 422/485</td> <td rowspan="2">plug</td> </tr> <tr> <td>GP-4201TW</td> <td>RS-232C</td> </tr> <tr> <td>GP-4203T</td> <td>RS-485 (for MPI)</td> <td>socket</td> </tr> </table>	GP-4201T	RS-232C/ 422/485	plug	GP-4201TW	RS-232C	GP-4203T	RS-485 (for MPI)
ST-400	RS-422	plug																		
ST-401	RS-232C																			
ST-402	RS-485 (for MPI)	socket																		
ST-403	RS-232C/ 422	plug																		
GP-4201T	RS-232C/ 422/485	plug																		
GP-4201TW	RS-232C																			
GP-4203T	RS-485 (for MPI)	socket																		
COM2	D-Sub 9-pin plug RS-422	D-Sub 9-pin plug RS-422/485																		
	 <p>* For ST-402 only</p>	 <p>*For GP-4201TW only</p>																		

4.3 Signals of COM ports

4.3.1 Signals of COM1

For ST-400

RS-422 (plug)

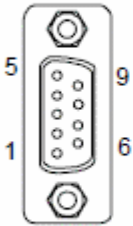
Pin Connection	Pin No.	Signal	Signal Name	Direction
 <p>(male)</p>	1	RDA	Receive data A	Input
	2	RDB	Receive data B	Input
	3	SDA	Send data A	Output
	4	ERA	Enable receive A	Output
	5	SG	Ground	-
	6	CSB	Clear send B	Input
	7	SDB	Send data B	Output
	8	CSA	Clear send A	Input
	9	ERB	Enable receive B	Output

For ST-401

RS-232C (plug)

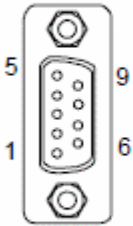
Pin Connection	Pin No.	Signal	Signal Name	Direction
 <p>(male)</p>	1	CD	Carrier detect	Input
	2	RD	Receive data	Input
	3	SD	Send data	Output
	4	ER	Enable receive	Output
	5	SG	Ground	-
	6	DR	Data set ready	Input
	7	RS	Request send	Output
	8	CS	Clear send	Input
	9	RI	Ring indicate	Input

For ST-402

RS-485 (for MPI) (socket)

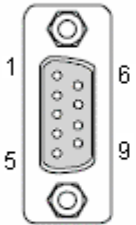
Pin Connection	Pin No.	Signal	Signal Name	Direction
 <p>(female)</p>	1	NC	No connection	-
	2	NC	No connection	-
	3	LINE(+)	Line (+)	In/Output
	4	RTS	Request Send	Output
	5	SG	Ground	-
	6	5V	5V External Output *	Output
	7	NC	No connection	-
	8	LINE(-)	Line (-)	In/Output
	9	NC	No connection	-

* You can supply power to the Siemens PROFIBUS connector only. You cannot supply power to the device/PLC.

For ST-403

RS-232C/422 (plug)

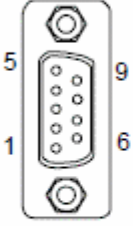
Pin Connection	Pin No.	Signal	Signal Name	Direction
 <p>(male)</p>	1	CD/RDA	Carrier detect /Receive data A	Input /Input
	2	RD/RDB	Receive data /Receive data B	Input /Input
	3	SD/SDA	Send data/Send data A	Output /Output
	4	ER/ERA	Enable receive /Enable receive A	Output /Output
	5	SG/SG	Ground/Ground	-
	6	DR/CSB	Data set ready/Clear send B	Input /Input
	7	RS/SDB	Request send /Send data B	Output /Output
	8	CS/CSA	Clear send/Clear send A	Input /Input
	9	RI/ERB	Ring indicate /Enable receive B	Input /Output

For GP-4201T/TW

RS-232C (plug)

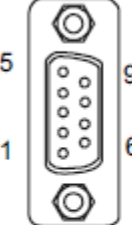
Pin Connection	Pin No.	RS-232C		
		Signal Name	Direction	Meaning
 <p>(GP unit side)</p>	1	CD	Input	Carrier Detect
	2	RD(RXD)	Input	Receive Data
	3	SD(TXD)	Output	Send Data
	4	ER(DTR)	Output	Data Terminal Ready
	5	SG	-	Signal Ground
	6	DR(DSR)	Input	Data Set Ready
	7	RS(RTS)	Output	Request to Send
	8	CS(CTS)	Input	Send possible
	9	CI(RI)/VCC	Input/-	Called Status Display +5V±5% Output 0.25A*1
	Shell	FG	-	Frame Ground (Common with SG)

*1: RI and VCC of Pin 9 are switched on the software.

VCC Output is not protected from overcurrent.

Please follow the current rating to avoid false operation or breakdown.

For GP-4203T

RS-485 (for MPI) (socket)

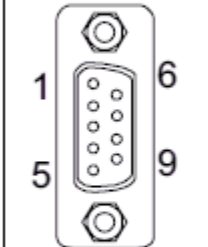
Pin Connection	Pin No.	RS-485 (isolation)		
		Signal Name	Direction	Meaning
 <p>GP unit side</p>	1	NC	–	no connection
	2	NC	–	no connection
	3	Line A	Input/Output	Data A (+)
	4	RS(RTS)	Output	Request to Send
	5	SG	–	Signal Ground
	6	VCC	–	+5V±5% External Output ⁽¹⁾
	7	NC	–	no connection
	8	Line B	Input/Output	Data B (-)
	9	NC	–	no connection
	Shell	FG	–	Frame Ground ⁽²⁾ (Not connected with SG)

*1: You can supply power to the Siemens PROFIBUS connector only. You cannot supply power to the device/PLC.

*2: The SG and FG terminals are isolated.

4.3.2 Signals of COM2

For ST-400/401/403

None

For ST-402

RS-422 (plug)

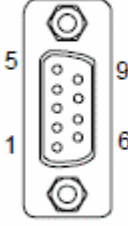
Pin Connection	Pin No.	Signal	Signal Name	Direction
 <p>(male)</p>	1	RDA	Receive data A	Input
	2	RDB	Receive data B	Input
	3	SDA	Send data A	Output
	4	ERA	Enable receive A	Output
	5	SG	Ground	-
	6	CSB	Clear send B	Input
	7	SDB	Send data B	Output
	8	CSA	Clear send A	Input
	9	ERB	Enable receive B	Output

For GP-4201T/ 4203T

None

For GP-4201TW

RS-422/485(plug)

Pin Connection	Pin No.	RS-422/RS-485		
		Signal Name	Direction	Meaning
 <p>(GP unit side)</p>	1	RDA	Input	Receive Data A (+)
	2	RDB	Input	Receive Data B (-)
	3	SDA	Output	Send Data A (+)
	4	ERA	Output	Data Terminal Ready A (+)
	5	SG	-	Signal Ground
	6	CSB	Input	Send Possible B (-)
	7	SDB	Output	Send Data B (-)
	8	CSA	Input	Send Possible A (+)
	9	ERB	Output	Data Terminal Ready B (-)
	Shell	FG	-	Frame Ground (Common with SG)

4.4 Multilink Connection

For GP4000 series, some communication drivers do not support multi-link connection (n:1) via RS-422.

When converting the project file with the setting of the communication driver that does not support multi-link connection (n:1) via RS-422, the connection is automatically converted to (1:1).

For the communication drivers that support serial multi-link, see [[Which drivers support serial multilink communication?](#)]

(http://www.pro-face.com/otasuke/files/manual/gpproex/new/device/com_mlnk.htm).

4.5 Internal 2-Port feature for Mitsubishi PLC

For GP-4501TW, the internal 2-Port feature for Mitsubishi PLC cannot be used.

If [GP Setup]->[Mode Settings]->[Option]->[Internal 2 port] is selected on GP-PRO/PBIII, the following message will appear when converting the project file with the GP-Pro EX Project Converter.

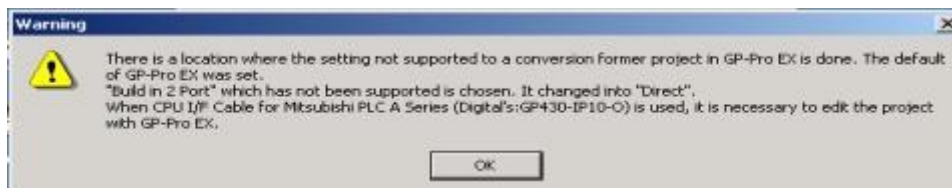

4.6 Cable Diagram at the time of replacement

The connection cable for ST-400 series can be used for GP4000 series. But please note that there are precautions and restrictions as described below.

IMPORTANT

- Please check the connection configurations GP4000 series supports with GP-Pro EX Device/PLC Connection Manual before using a connection cable.
(<http://www.pro-face.com/otasuke/files/manual/gpproex/new/device/index.htm>).
- **The Siemens MPI connection cable** cannot be used.
Please refer to the above-mentioned GP-Pro EX Device/PLC Connection Manual and prepare a connection cable for GP4000 series newly.
- **For ST-400 users:**
After replacing ST-400 with GP4000 series, the device will be connected on the COM2 port. (The same cable diagram can be used.)
Before **GP4000 series is connected, be sure to change the port setting to [COM2] on the Device/PLC setting. Please check the communication settings in the GP-Pro EX Device/PLC Connection Manual just in case.**