

---

## PS-3650A / PS-3651A Series

### Battery Unit Installation Guide

---

#### Caution

Be sure to read the "Warning/Caution Information" on the attached sheet before using the product.

The PS-3650A / PS-3651A series battery unit is a unit that functions as uninterruptible power supply system on PS-3650A / PS-3651A Series AC type (hereafter referred to as PS-A).

This battery supplies power during a power failure. By setting the software of the unit, it is possible to execute automatic shutdown, hibernation, and stand-by procedures in case of a power failure.

---

## Package Contents

---

- (1) PS-3650A / PS-3651A Series Battery Unit (1)  
(attached to the rear of a PS-3650A unit)
- (2) PS-3650A / PS-3651A Series Battery Unit Installation Guides (1) <This Guide>

This unit has been carefully packed, with special attention to quality. However, should you find anything damaged or missing, please contact your local distributor immediately.

---

## Driver and Manual

---

In order to use this battery unit, a battery unit driver is required.

If your PS-A is an OS pre-installed type model, the driver has been installed.

If not, visit our website and download the battery unit driver on your PS-A.

For further information on the battery unit driver, refer to the following PDF manual.

- PS-3650A / PS-3651A Series Battery Unit Driver Manual

The driver and manual can be downloaded from Pro-face Home Page.

#### URL

<http://www.pro-face.com/otasuke/>

## Dimensions

### ■ PS-3650A Series AC type with a battery unit

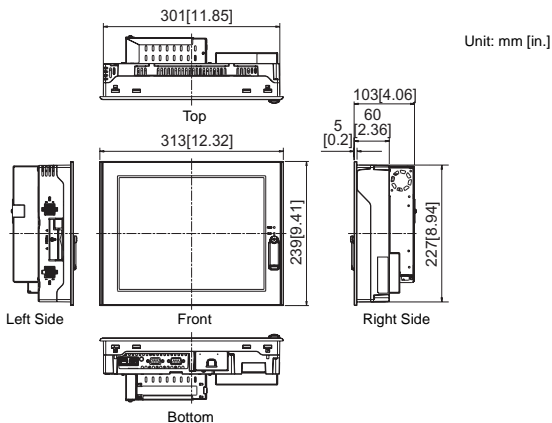

#### IMPORTANT

- The battery unit is equipped under the expansion board cover. When using a PCI board, ensure that the PCI board does not tilt and it does not touch the battery unit. When fixing the PCI board with the expansion board support, install the board to the unit, paying attention to the tilt of the board. Do not press the board from the top with force.

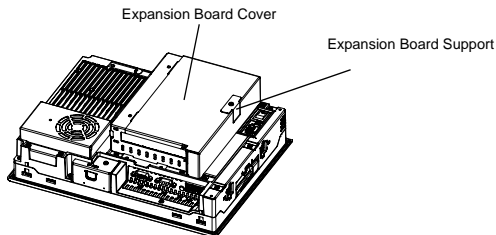

■ PS-3651A Series AC type with a battery unit

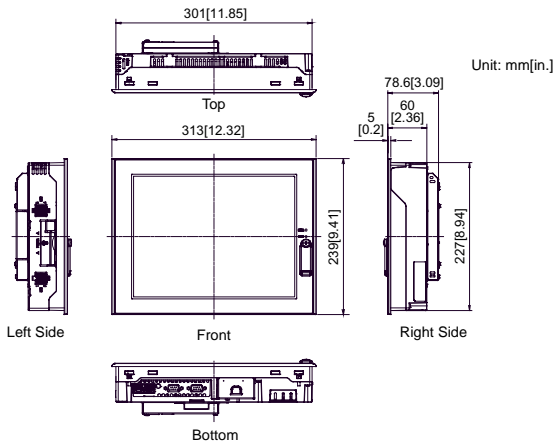

## General Specifications

Electrical, environmental and structural specifications for the battery correspond to PS-A. For further information, refer to the PS-3650A / PS-3651A User Manual or PS-3650A / PS-3651A Series Hardware Manual.

The weight of the battery unit is shown below.

|        |              |
|--------|--------------|
| Weight | 900g or less |
|--------|--------------|

## Backup Battery

### 1. About the Battery

The battery unit is equipped with a Ni-Cd battery for backup.

#### ■ Charging time

The power-on time required from when the battery fully discharges till it is completely charged is about 14 to 16 hours.

#### IMPORTANT

- If the PS-A unit is not used for an extensive period of time, or during initial stage of new installation of the PS-A unit, the backup battery may discharge. The battery must be fully charged with the unit powered on AC for 16 hours or more. If the battery is insufficiently charged, the backup battery function may not work properly.

#### ■ Service life

| Conditions for the battery   | Service life (years) |
|--|----------------------|
| Hours of use per a day:<br>24 hours<br>(continuous use)<br>Backup operation:<br>Once a month<br>Surrounding air temperature:<br>30°C | 5                    |
| Hours of use per a day:<br>24 hours<br>(continuous use)<br>Backup operation:<br>Once a month<br>Surrounding air temperature:<br>40°C | 4                    |

#### IMPORTANT

- The service life of the battery varies depending on its usage condition. The values shown above do not guarantee your battery's service life. It is strongly recommended that the battery be replaced new one as early as possible.

### 2. Cautions for the battery

#### DANGER

- To prevent the battery from leakage, heat generation or explosion, be sure to read as follows;
  - Do not heat or throw the battery into a fire.
  - Do not disassemble or modify the battery.
- If the battery liquid, strong alkaline, gets in your eyes, immediately rinse your eyes with clean water and consult a doctor, since it may cause to lose eyesight.

## ⚠ WARNING

- Do not get the battery in the water and salty water, and also do not get it wet. Doing so may cause the battery heat generation and rust. If rust in the battery is found, the function of the gas blowdown valve may not work properly. Moreover, continuing use of this situation of the battery may cause an explosion.
- Do not remove the outer covering tube and do not scratch it. Doing so may cause the battery leakage, heat generation, and an explosion.
- If the battery liquid, strong alkaline, contacts your skin and cloths, be sure to wash it with clean water. Otherwise, it may develop skin lesions.

## ⚠ CAUTION

- Do not give the battery a strong shock, and do not throw it. Doing so may cause the battery leakage, heat generation, and an explosion.
- Do not carry the battery as holding the connector and the lead wire. Doing so may cause the battery damaged.
- Avoid leaving the battery in a high temperature place such as a direct sunlight spot, the inside of a sun-heated car, near water, and in front of a stove. Doing so may cause the battery leakage, or decline the functions and life-time.
- The battery can be recycled. For recycling your used battery, follow the regulations and instructions in your area.

## Replacing Battery Unit

When battery replacement is needed, replace the whole battery unit.

The model type of the replacement battery unit is "PS365XA-BATTU".

Here is an example of the battery unit replacement procedure for PS-3650A Series, as indicated below. In case of PS-3651A Series, (2) and (3) are unnecessary steps.

## ⚠ WARNING

- To avoid an electric shock, turn off the power of the PS-A before installation/removal.
- (1) Turn off the power of the PS-A, and remove the power cable. Put the PS-A unit down on a flat place so that the display side keeps down.
  - (2) Remove the two screws of the expansion board cover, and then remove the board cover. For PS-3651 Series, this step is unnecessary.

### NOTE

- When a PCI board is installed on the PS-A unit, remove the expansion board support first, and then remove the expansion board cover and the PCI board.

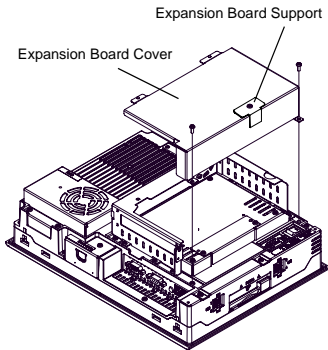

- (3) Remove the four screws of the expansion board base, and then remove the board base. For PS-3651A Series, this step is unnecessary.

Expansion Board Base

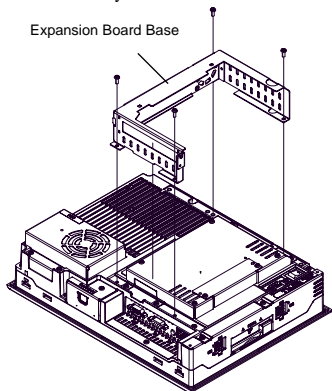

- (4) Remove the two screws of the cable cover, which are on the battery unit, and remove the cable cover.

Cable Cover

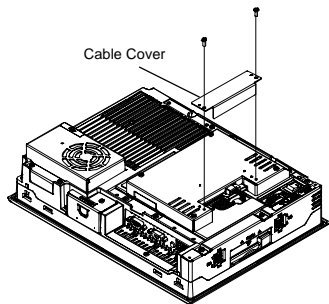

- (5) Pull out the two connectors, Backup Output Connectors (CN2) and Control

Signal Connector (CN3), as indicated below.

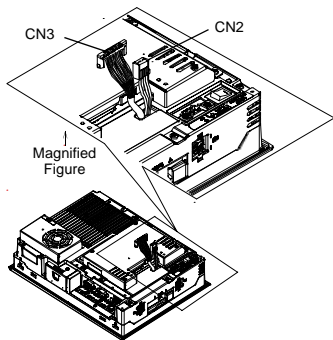

**NOTE**

- Pull out the Backup Output Connector (CN2) as keeping pressing the right side of the pick of the connector.

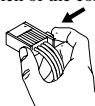

Removal instruction  
for Backup Output  
Connector (CN2)

- Pull out the Control Signal Connector (CN3) as keeping pressing both sides of the picks of the connector.

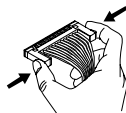

Removal instruction  
for Control Signal Con-  
nector (CN3)

- (6) Remove the four screws of the battery unit, and remove the battery unit.

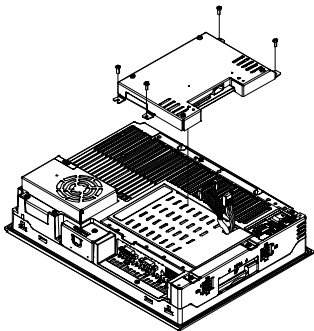

- (7) Install a new battery unit in place. Return the cable cover and expansion board cover to their original positions on the PS-A unit by reversing steps (2) to (6) above. The tightening torque is 0.5 to 0.6 N•m.

## Replacing HDD Unit

When replacing a HDD Unit, it is necessary to remove the battery unit.

Referring to the battery unit replacement procedure described above, remove/install the battery unit.

For HDD Unit replacement procedure, refer to the installation guides for HDD Unit.

### Inquiry

Do you have any questions about difficulties with this product? Please access our site anytime that you need help with a solution.

<http://www.pro-face.com/otasuke/>

### Note

Please be aware that Digital Electronics Corporation shall not be held liable by users for any damages such as system breakage failure, data loss, a second accident or opportunity loss caused by a battery failure, and etc., arising from the uses of this product.

Digital Electronics Corporation  
8-2-52 Nanko-higashi  
Suminoe-ku, Osaka 559-0031  
JAPAN  
TEL: +81-(0)6-6613-3116  
FAX: +81-(0)6-6613-5888  
<http://www.pro-face.com/>

© Copyright 2007 Digital Electronics Corporation. All rights reserved.