

Pro-face®

PS-3650A/PS-3651A

User Manual

Preface

Thank you very much for purchasing a Pro-face PS-3650A/PS-3651A Unit, hereafter referred to as the PS-A.

Before using the PS-A, read this manual thoroughly to familiarize yourself with the PS-A's operation procedures and functions.

NOTICE

1. Copying this manual's contents, either in whole or in part, is prohibited without the express permission of Digital Electronics Corporation, Japan.
2. The information contained in this manual is subject to change without notice.
3. If you find any errors or omissions in this document, please contact Digital Electronics Corporation to report your findings.
4. Regardless of Clause 3 above, Digital Electronics Corporation shall not be held responsible for any damage, losses or third-party damage resulting from the use of this product.

Product names used in this manual are the trademarks / registered trademarks of their respective owners.





© 2006 Digital Electronics Corporation. All rights reserved.

Essential Safety Precautions

All safety-related procedures stated in this document must be followed to operate the PS-A correctly and safely. Be sure to read this and any related documents thoroughly to understand the correct operation and functions of the PS-A unit.





Safety Icons

Throughout this manual, these icons provide essential safety information for PS-A operation procedures requiring special attention. These icons indicate the following levels of danger:

 WARNING	Indicates situations where severe bodily injury, death or major equipment damage can occur.
 CAUTION	Indicates situations where slight bodily injury or minor equipment damage can occur.
	Indicates actions or procedures that should NOT be performed.
	Indicates actions or procedures that MUST be performed to ensure correct unit operation.

WARNING

System Design

-  Do not create PS-A touch panel switches that could possibly endanger the safety of personnel or equipment. A malfunction of the PS-A unit, its I/O unit(s), cable(s), or other related equipment can cause unexpected output signals, leading to a serious accident. Be sure to design all important machine operation switches so they are operated via a separate control system, and not via the PS-A.
-  Do not create PS-A touch panel switches to control machine safety operations, such as an emergency stop switch. Install these switches as separate hardware switches, otherwise severe bodily injury or equipment damage can occur.
-  Be sure to design your system so that a communication fault between the PS-A and its host controller will not cause equipment to malfunction. This is to prevent any possibility of bodily injury or equipment damage.
-  Do not use the PS-A as a warning device for critical alarms that can cause serious operator injury, machine damage or can halt system operation. Critical alarm indicators and their control/activator units must be designed using stand-alone hardware and/or mechanical interlocks.
-  Do not use the PS-A with aircraft control devices, aerospace equipment, central trunk data transmission (communication) devices, nuclear power control devices, or medical life support equipment, due to these devices' inherent requirements of extremely high levels of safety and reliability.

 When using the PS-A with transportation vehicles (trains, cars, and ships), disaster and crime prevention devices, various types of safety equipment, and medical devices that are not life-support related, use redundant and/or failsafe system designs to ensure proper reliability and safety.

 After the PS-A unit's backlight burns out the touch panel is still active, unlike the PS-A unit's "Standby Mode". If the operator fails to notice that the backlight is burned out and touches the panel, a potentially dangerous machine operation error can occur. Therefore, do not create PS-A unit touch panel switches that may cause injury and/or equipment damage.

If your PS-A unit's backlight suddenly turns OFF, use the following steps to determine if the backlight is actually burned out.

- 1) If the PS-A unit's "Backlight Control" is not set and the screen has gone blank, your backlight is burned out.
- 2) If the PS-A unit's "Backlight Control" is set to Standby Mode and the screen has gone blank, and touching the screen or performing another input operation does not cause the display to reappear, your backlight is burned out.

Handling

 Do not modify the PS-A unit. Doing so may cause a fire or an electric shock.

 Do not operate the PS-A in an environment where flammable gases are present, since it may cause an explosion.

Wiring

 To prevent an electric shock be sure to disconnect your PS-A unit's power cord from the power supply before wiring the PS-A.

 Do not use voltage beyond the PS-A unit's specified range. Doing so may cause a fire or an electric shock.

Maintenance

 Do not connect or disconnect Host and PS-A unit communication cables while the PS-A is turned ON.

 The PS-A uses a lithium battery for backing up its internal clock data and the battery may explode if it is replaced incorrectly. When replacement is required, use a Pro-face-designated replacement product.



 [7.6 Replacing the Internal Battery \(page7-15\)](#)

CAUTION

Installation

-  Be sure all cable connectors are securely attached to the PS-A unit. A loose connection may cause incorrect input or output signals.

Wiring

-  Be sure to ground the PS-A unit's FG wire separately from other equipment FG lines. Also, be sure to use a grounding resistance of 100Ω or less and a 2mm² or thicker wire, or your country's applicable standard. Otherwise, electric shock or malfunctions may result.
-  Be sure to use only the designated torque to tighten the PS-A unit's terminal block screws. If these screws are not tightened firmly, it may cause a short-circuit, fire or incorrect unit operation.
-  Be sure that metal particles and wiring debris do not fall inside the PS-A unit. They can cause a fire, malfunction or incorrect unit operation.







Maintenance

-  Do not reset or turn the PS-A OFF, or insert or remove the CF Card while the PS-A unit's CF Card or hard disk is being accessed. Otherwise, CF Card and the hard disk internal data may be damaged or lost.

Unit Disposal

-  When the product is disposed of, it should be done so according to your country's regulations for similar types of industrial waste.

General Safety Precautions

-  Do not press on the PS-A unit's display with excessive force or with a hard object, since it can damage the display. Also, do not press on the touch panel with a pointed object, such as the tip of a mechanical pencil or a screwdriver, since doing so can damage the touch panel.
-  Do not install the PS-A where the ambient temperature exceeds the specified range. Doing so may cause a unit malfunction.
-  To prevent abnormally high temperatures from occurring inside the PS-A, do not restrict or block the PS-A unit's rear-face ventilation slots.
-  Do not operate the PS-A in areas where large, sudden temperature changes can occur. These changes can cause condensation to form inside the PS-A, possibly causing it to malfunction.
-  Do not allow water, liquids or metal fragments to enter inside the PS-A unit's case, since they can cause either a malfunction or an electric shock. For use in Pollution Degree 2 environment.
-  Do not operate or store the PS-A in locations where it can be exposed to direct sunlight, high temperatures, excessive dust, moisture or vibration.



- ⊘ Do not operate or store the PS-A where chemicals evaporate, or where chemicals are present in the air.
 - Corrosive chemicals : Acids, alkalines, liquids containing salt
 - Flammable chemicals : Organic Solvents
- ⊘ Do not use paint thinner or organic solvents to remove dirt or oil from the PS-A unit's surface. Instead, use a soft cloth moistened with a diluted neutral detergent.
- ⊘ Do not use or store the PS-A in areas with direct sunlight, since the sun's ultraviolet rays may cause the LCD's quality to deteriorate.
- ⚠ Do not store the PS-A in an area where the temperature is lower than that recommended in the PS-A unit's specifications. Doing so may cause the LCD display's liquid to congeal, which can damage the LCD. Also, if the storage area's temperature becomes higher than the specified level, the LCD's liquid may become isotropic, causing irreversible damage to the LCD. Therefore, only store the PS-A in areas where temperatures are within the PS-A unit's specifications.
- ⚠ After turning OFF the PS-A, be sure to wait a few seconds before turning it ON again. The PS-A may not operate correctly if it is restarted too quickly.
- ⚠ Due to the possibility of unexpected accidents, be sure to back up the PS-A unit's data regularly.

LCD Panel Usage Precautions

- The LCD panel's liquid contains an irritant. If the panel is damaged and any of this liquid contacts your skin, immediately rinse the area with running water for at least 15 minutes. If the liquid gets in your eyes, immediately rinse your eyes with running water for at least 15 minutes and consult a doctor.
- The PS-A unit's LCD screen may flicker or show unevenness in the brightness of certain images or at some contrast settings. This is an LCD characteristic and not a product defect.
- Some LCD screens may have differences in brightness and tone. Please be aware of this difference when using multiple units side by side.
- Depending on the ambient temperature, LCD screens may sometimes look whitish (at high temperatures) or blackish (at low temperatures). This is an LCD characteristic and not a product defect.
- Some of PS-A unit's LCD screens may contain black and white colored pixels. This is an LCD characteristic and not a product defect.
- Extended shadows, or "Crosstalk" may appear on the LCD screen. This is an LCD characteristic and not a product defect.
- The color displayed on the PS-A unit's LCD screen may appear different when seen from outside the specified viewing angle. This is an LCD characteristic and not a product defect.
- When the same image is displayed on the PS-A unit's screen for a long period, an afterimage may appear when the image is changed. If this happens, turn off the PS-A, wait 10 seconds and then restart the unit. This is an LCD characteristic and not a product defect.
- To prevent an afterimage:
 - Set the PS-A unit's display OFF feature when you plan to display the same screen image for a long period of time.
 - Change the screen image periodically and try to not display the same image for a long period of time.

Information Symbols

This manual uses the following icons:

	Indicates a warning or a product limitation. Be sure to follow the instructions given with this icon to ensure the safe operation of the PS-A.
	Contains additional or useful information.
(1) (2)	Indicates steps used to accomplish a given task. Be sure to follow these steps in the order they are written.
*	Indicates useful or important supplemental information.
	Indicates pages containing related information.

Package Contents

The following items are included in the PS-A unit's package. Before using the PS-A, please check that all items listed here are present.

PS-A Unit (1)

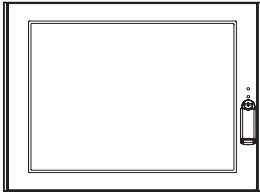

Installation Guide (1)

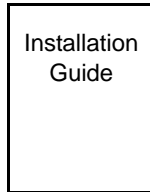

Installation Fasteners (4/set)

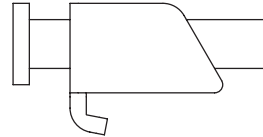

Installation Gasket (1) (Attached to the PS-A unit)



USB Holder (2) sets (USB Holder (1) + USB Cover (2)) x 2

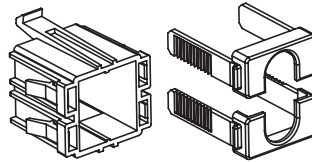

Power Plug (1) (Attached to the PS-A unit)

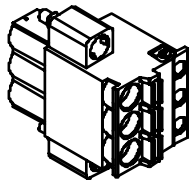

AC type 5.08mm
[0.2 in.] pitch

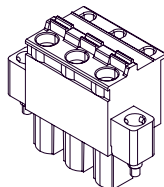

DC type 7.62mm
[0.3 in.] pitch

Power Cord for the AC Type(1)

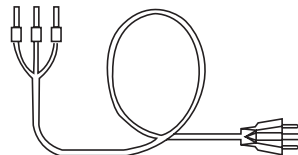

IMPORTANT

- The power cord for the AC type is designed only for AC100V use. If using other voltages, you should use a different cord in conformity with that voltage.
- The power cord for the AC type is designed exclusively for this product and it cannot be used for other electric devices.
- The power cord for the DC type is not included in the DC type package contents.

NOTE

- If your PS-A unit contains a built-in accessory, that accessory's Installation Guide will also be included in the PS-A's packing box. Please check that all items normally included with that accessory are also included in this box.

This unit has been carefully packed, with special attention to quality. However, should you find anything damaged or missing, please contact your local PS-A distributor immediately.

UL/CSA Approval

The following models are UL/CSA listed products. (UL File No. E220851, CSA File No.219866)

Product Model No.	UL/CSA Registration Model No.
PS3650A-T41	3480801-02
PS3651A-T41	3480801-01
PS3650A-T41-24V	3480801-12
PS3651A-T41-24V	3480801-11

These models conform to the following standards:

- UL508 Industrial Control Equipment
- CSA-C22.2, No.142-M1987 Process Control Equipment

<Cautions>

Be aware of the following items when building the PS-A into an end-use product:

- The PS-A unit's rear face is not approved as an enclosure. When building the PS-A unit into an end-use product, be sure to use an enclosure that satisfies standards as the end-use product's overall enclosure.
- The PS-A unit should be mounted on a flat surface of a Type 4X (Indoor Use Only) and/or Type 12 Enclosure.
- The PS-A unit must be used indoors only.
- Install and operate the PS-A with its front panel facing outwards.
- If the PS-A is mounted so as to cool itself naturally, be sure to install it in a vertical panel. Also, it's recommended that the PS-A should be mounted at least 50 mm [1.97 in.] away from any other adjacent structures or machine parts. The temperature must be checked on the final product in which the PS-A is installed.

CE Marking

PS3650A-T41/PS3651A-T41 are CE marked products that conform to EMC directives and Low-voltage directive EN55011 Class A, EN61000-6-2, and EN60950.

PS3650A-T41-24V/PS3651A-T41-24V are CE marked products that conform to EMC directives EN55011 Class A and EN61000-6-2.

FCC Statement

United States FCC Part 15, Subpart B, Class A EMI Compliance Statement:

NOTE: This equipment has been tested and found to comply with the limits for a Class A digital device, pursuant to part 15 of the FCC Rules. These limits are designed to provide reasonable protection against harmful interference when the equipment is operated in a commercial environment. This equipment generates, uses, and can radiate radio frequency energy and, if not installed and used in accordance with the instruction manual, may cause harmful interference to radio communications. Operation of this equipment in a residential area is likely to cause harmful interference in which case the user will be required to correct the interference at his or her own expense.

Contents

Preface.....	1
Essential Safety Precautions	2
Information Symbols	6
Package Contents	7
UL/CSA Approval	8
CE Marking	8
FCC Statement	9
Contents.....	10
Chapter 1 Introduction	
1.1 Prior to Operating the PS-A Unit.....	1-2
1.1.1 Front Access Mask	1-3
1.1.2 Power Supply.....	1-3
1.2 System Design.....	1-4
1.3 Accessories	1-5
1.4 Part Names and Functions	1-6
Chapter 2 Specifications	
2.1 General Specifications.....	2-2
2.1.1 Electrical	2-2
2.1.2 Environmental.....	2-2
2.1.3 Structural.....	2-4
2.2 Performance Specifications	2-5
2.2.1 Performance Specifications	2-5
2.2.2 Display	2-6
2.2.3 Touch Panel	2-6
2.2.4 Expansion Slot.....	2-6
2.3 Interface Specifications.....	2-7
2.3.1 Serial Interfaces (COM1)	2-7
2.3.2 RAS Interface.....	2-9
2.4 Dimensions	2-10
2.4.1 PS-3650A External Dimensions.....	2-10
2.4.2 PS-3651A External Dimensions.....	2-12
2.4.3 Panel Cut Dimensions	2-13
2.4.4 Installation Fasteners.....	2-13
2.4.5 Dimensions attached RS-232C/RS-485 exchangeable unit	2-14

Chapter 3 Hardware Installation

3.1 Installation.....	3-2
3.1.1 Installation Procedures	3-2
3.2 Wiring Precautions.....	3-7
3.2.1 Connecting the Power Cord.....	3-7
3.2.2 Connecting the Power Supply	3-11
3.2.3 Grounding	3-12
3.2.4 I/O Signal Line Placement	3-12
3.3 Peripheral Devices Installation.....	3-13
3.3.1 Main Memory Installation	3-13
3.3.2 PCI Board Installation	3-15
3.3.3 PCMCIA (PC Card) Installation/Removal	3-17
3.3.4 CF Card Insertion/Removal	3-18
3.3.5 USB Holder Attachment/Removal.....	3-20

Chapter 4 System Setup

4.1 Setup Procedures	4-2
4.2 System Parameters	4-4
4.2.1 Main	4-4
4.2.2 Advanced.....	4-6
4.2.3 Intel.....	4-17
4.2.4 Security.....	4-27
4.2.5 Boot	4-28
4.2.6 Exit.....	4-29

Chapter 5 Setting up Software

5.1 Software Configuration	5-2
5.2 Setting Up Your PS-A Unit.....	5-2
5.2.1 Setting Up an HDD with no Pre-installed OS.....	5-2
5.2.2 Setting Up an HDD with Pre-installed OS.....	5-4
5.3 PS-A Dedicated Software	5-6
5.3.1 Driver	5-6
5.3.2 Special Application Program Features.....	5-8
5.4 Cautions When Using Windows® 2000/Windows® XP	5-11
5.4.1 Automatic System Log-on Setup	5-11
5.4.2 Uninterrupted Power Supply System (UPS)	5-11
5.4.3 Changing System Settings	5-12
5.4.4 NTFS File System Conversion.....	5-12

Chapter 6 PS-A Monitoring Features

6.1 RAS Features	6-2
6.1.1 RAS Features	6-2
6.2 Setting Menus.....	6-8
6.3 Monitoring the PS-A Status.....	6-10
6.3.1 Description	6-10
6.3.2 Setup Procedure	6-10
6.4 Checking the Status of the PS-A Being Monitored	6-14
6.4.1 Description	6-14
6.4.2 Setup Procedure	6-14
6.5 Checking the Error Log List	6-15
6.5.1 Description	6-15
6.5.2 Setup Procedure	6-16
6.6 Monitoring Errors from a Remote Server	6-18
6.6.1 Description	6-18
6.6.2 System Configuration.....	6-19
6.6.3 Monitoring using Pro-Server with Pro-Studio or Pro-Server EX.....	6-23
6.7 Restarting/Shutting Down the PS-A from a Remote Server	6-25
6.7.1 Description	6-25
6.7.2 Setup Procedure	6-26
6.8 Setup Guide for the System Monitor Property	6-27
6.8.1 Voltage / Fan / Temperature / Backlight / SMART / DIN0 / DIN1	6-28
6.8.2 Remote RAS	6-29
6.8.3 Watchdog Timer	6-30
6.8.4 Remote Reset.....	6-31
6.9 Setup Guide for the System Monitor Screen	6-32
6.9.1 Voltage / Fan / Temperature / Backlight / Watchdog Timer	6-33
6.9.2 SMART	6-34
6.10 Error Messages	6-35
6.11 Restrictions	6-38

Chapter 7 Maintenance

7.1 Cleaning the Display.....	7-2
7.2 Cleaning the Fan Filter	7-3
7.3 Periodic Inspection Items.....	7-5
7.4 Replacing the Installation Gasket	7-6
7.5 Replacing the Backlight	7-8
7.5.1 Procedure for replacing the backlight of PS-3650A.....	7-9
7.5.2 Procedure for replacing the backlight of PS-3651A.....	7-12
7.6 Replacing the Internal Battery	7-15

Chapter 8 Troubleshooting

8.1 Problems and Countermeasures	8-2
8.2 Recovery Procedure	8-5
8.2.1 PS-A with no Pre-installed OS	8-5
8.2.2 PS-A with Pre-installed OS (Windows® 2000/Windows® XP)	8-5

Appendices

1 I/O Map	A-2
2 Memory Map	A-3
3 Interrupt Map	A-4
4 License Agreement	A-5

1 Introduction

1. Prior to Operating the PS-A Unit
2. System Design
3. Accessories
4. Part Names and Functions

This chapter describes peripheral devices that can be connected to PS-A Series units along with the name and functions of each part.

1.1 Prior to Operating the PS-A Unit

The following procedures are prior to use the PS-A unit.

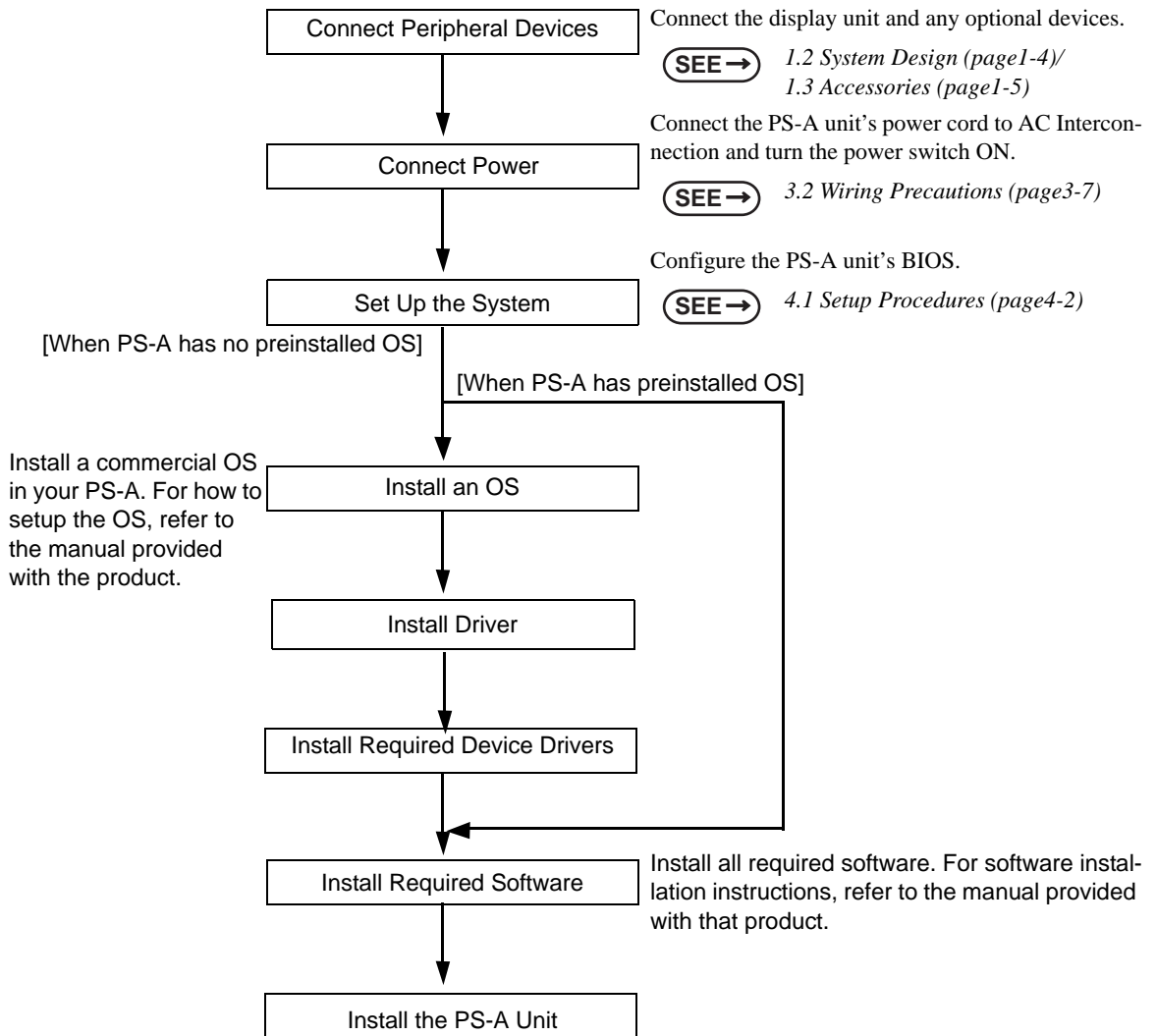

IMPORTANT

- After hardware setup is completed, the OS must be used to create partitions and format (initialize) the HDD before any data or applications can be saved to the hard disk drive. For details concerning these procedures, refer to the OS manufacturer's instruction manual.
- Whenever you turn the PS-A unit's power OFF, wait until the internal HDD stops spinning (approximately 5 seconds) before turning the power ON again.
- The PS-A's hard disk is designed for use with the Windows® 2000, Windows® XP. Other operating systems do not support this driver software, etc.

1.1.1 Front Access Mask

When you open the front maintenance hatch of the front unit, there are USB ports and a reset switch. If you want to prevent unwilling or unintentional accesses, change the DipSW settings to mask access from reset from the front side or the USB ports.

See the following for the place of the DipSW.

SEE → 2.3 Interface Specifications ■ Switch (page2-7)

1.1.2 Power Supply

About states of PS-A's power supply, there are three kinds of states, which are No Energization, Active State (Normal), and Soft OFF State^{*1}. Each state is outlined in the following.

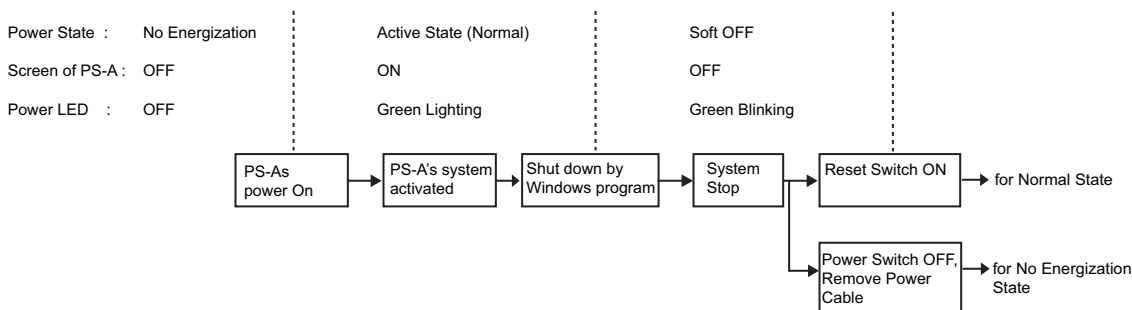

*1 The Soft OFF refers to the state that Windows[®] has been shut down and the power is provided only for the electric circuit to boot system. This Soft OFF State is different from what is System Standby set by Windows[®].

1.2 System Design

The following diagram illustrates the standard range of items that can be connected to the unit.

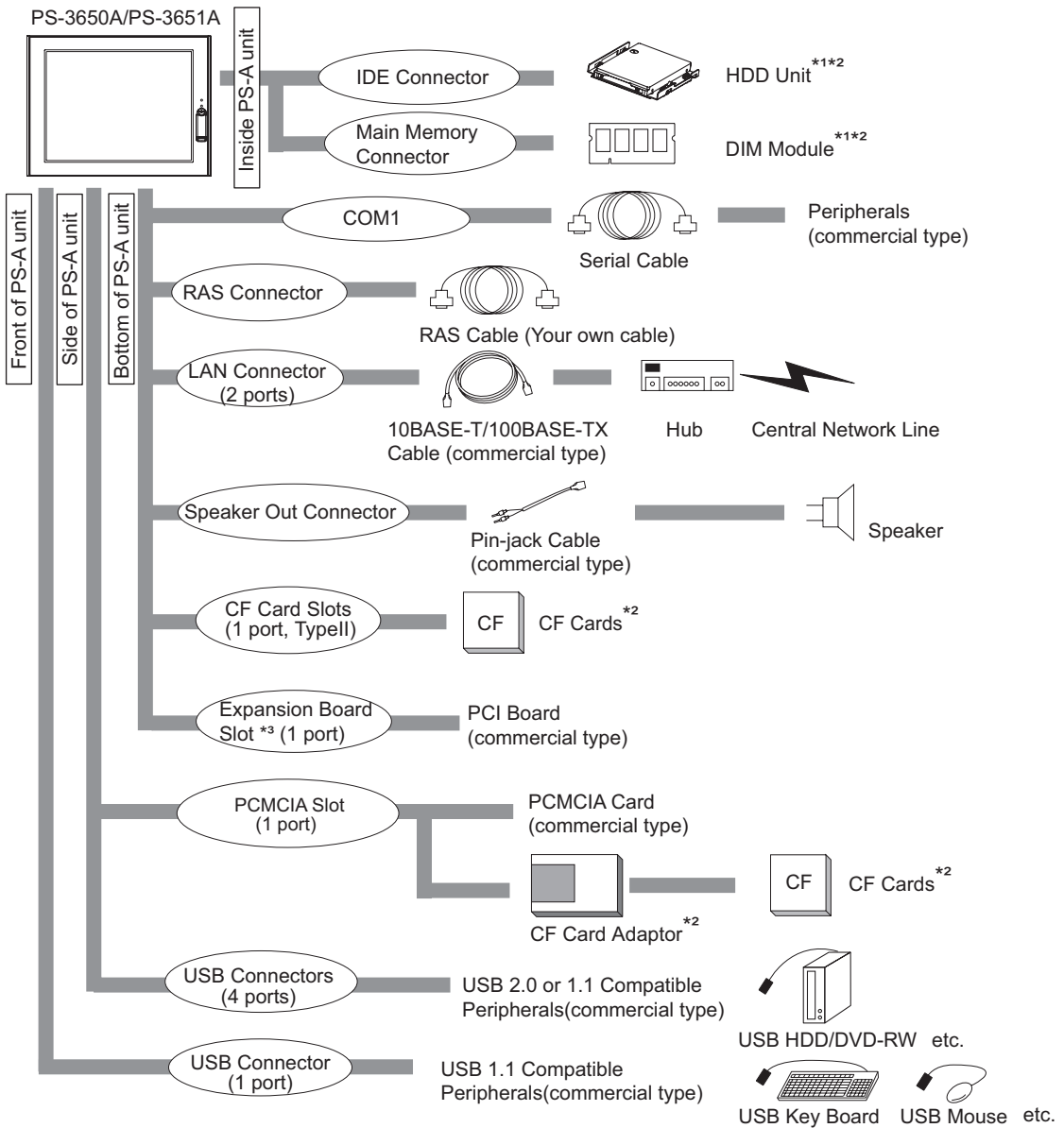

*1 Built-in accessory only

*2 The Pro-face's optional devices used with the PS-A. Please refer to "1.3 Accessories" for details.

*3 PS-3651A does not have an expansion board slot. PS-3650A only does.

IMPORTANT

- This diagram shows only the PS-A's internal layout and connectable devices. The user's actual design may differ.

1.3 Accessories

All accessories listed here are produced by Pro-face.

■ Optional Item

Product Name	Model No.	Description
DIM module	PSA-DDR512	Memory module 512MB
	PSA-DDR1G	Memory module 1GB
Hard Disk Unit	PS365XA-HD40	HDD Unit mounted a Type 2.5 Hard Disk (40GB without OS)
CF Card	CA3-CFCALL/128MB-0	Type 1 128MB
	CA3-CFCALL/256MB-0	Type 1 256MB
	CA3-CFCALL/512MB-0	Type 1 512MB
	CA6-CFCALL/1GB-01	Type 1 1GB
RS-232C/RS-485 conversion unit	PL-RC500	Unit for converting the RS-232C I/F to RS-485 I/F.

■ Maintenance Items

Product Name	Model No.	Description
Installation Fastener	CA3-ATFALL-01	Used to install the PS-A into a solid panel (4 pieces per a set).
Installation Gasket	CA3-WPG12-01	Provides dust and moisture resistance when PS-A is installed into a solid panel.
Replacement Backlight	CA5-BLU12XGA-01	Backlight for replacement
Protective panel sheet	CA5-DFS10-01	Disposable sheet that protects the PS-A unit's screen from dust. (5 sheets/set) (Hard type)
DC Power Supply Connector (Straight)	CA7-DCCNL-01	DC Power Supply Connector (5 connectors/set)
AC Power Supply Connector (Straight)	CA7-ACCNL-01	AC Power Supply Connector (5 connectors/set)

1.4 Part Names and Functions

The following images are of a PS-3650A/PS-3651A unit.

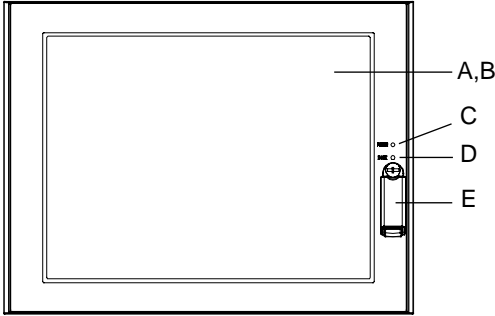

Front
(Common in PS-3650A / PS-3651A)

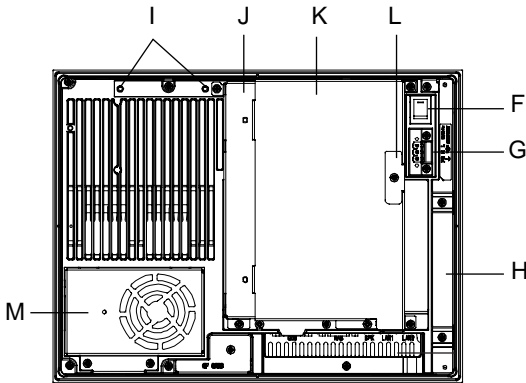

Rear
(PS3650A-T41)

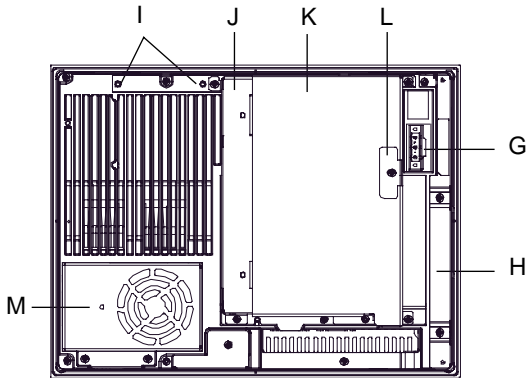

Rear
(PS3650A-T41-24V)

- A: Display
- B: Touch Panel
- C: Power LED / RAS Status lamp (POWER)

This status LED indicates the power current and operation status. The following table shows the display colors and corresponding status.

LED	PS-A Status
Green (lit)	Normal operation (power is ON).
Green (blinking)	System is NOT running (Soft OFF state).
Orange (lit)	System monitor error / Touch panel SELF TEST error.
Orange/ Red (blinking)	Backlight error.
Off	Power is OFF.

- D: HDD/IDE Access lamp (DISK)

LED	PS-A Status
Green (lit)	Access to HDD or IDE.
Off	No access to HDD or IDE.

- E: Front Cover
Inside, there is a Hardware Reset Switch (RESET) and a USB Interface 1 port (corresponding to USB Ver.1.1).
- F: Power switch
AC type only (PS3650A-T41/PS3651A-T41)
- G: Power supply connector
For connection, put a power plug (included) into the power cable.
- H: Mask Cover
- I: RS-232C/485 conversion unit hook holes
- J: Expansion Board Base
- K: Expansion Board Cover
- L: Expansion Board Support
- M: Fan Cover
- N: Memory Slot Cover
- O: IDE Cover

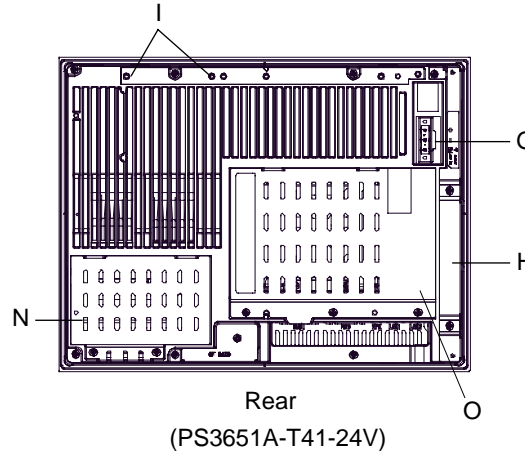
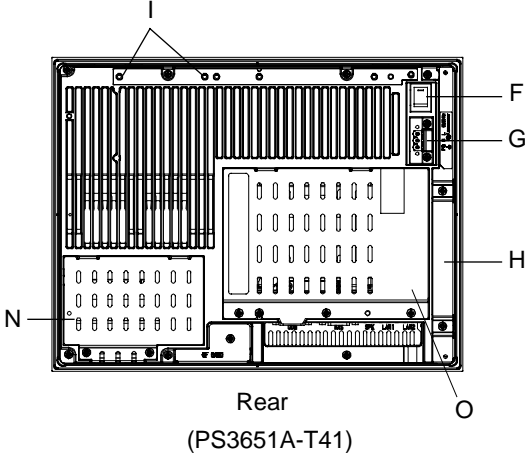

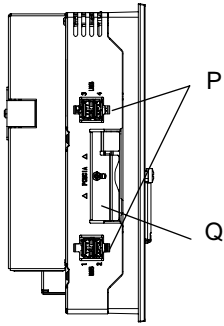

Left Side
(PS-3650A)

P: USB Interface (USB)

4 ports, USB 2.0 Compatible.

Uses a "TYPE-A" connector.

Power supply voltage	5V DC \pm 5%
Output current	Each port: 500mA(max.) 4 ports total: 500mA(max.)
Maximum communication distance	5m

Q: PCMCIA Slot Cover

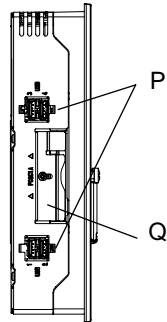

Left Side
(PS-3651A)

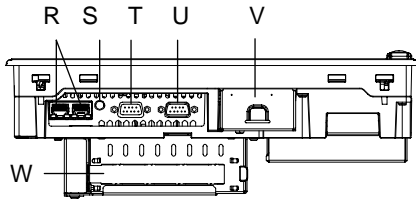

Bottom
(PS-3650A)

R: Ethernet Interface (LAN)

This interface corresponds to IEEE802.3, the Ethernet protocol (10BASE-T/100BASE-TX). It uses a modular jack connector which is RJ-45 type (Octupole).

S: Speaker Output Interface

It connects to the Speaker.

T: RAS interface (RAS)

U: Serial Interface (COM1)

(R1/+5V Switching available)

V: CF Card Cover

W: Expansion Slot

This is a slot that is mounted on a PCI board.

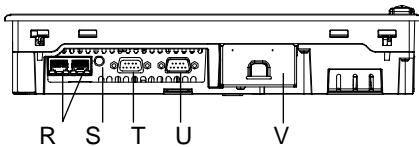

Bottom
(PS-3651A)

2 | Specifications

1. General Specifications
2. Performance Specifications
3. Interface Specifications
4. Dimensions

This chapter describes the general, functional and interface specifications of the PS-A as well as its part names and dimensions.

2.1 General Specifications

2.1.1 Electrical

		PS3650A-T41 PS3651A-T41	PS3650A-T41-24V PS3651A-T41-24V
Power Supply	Input Voltage	AC100/240V	DC24V
	Rated Voltage	AC85 to 265V	DC19.2 to 28.8V
	Rated Frequency	50/60Hz	-
	Allowable Voltage Drop	1 cycle or less (Voltage drop interval must be 1s or more.)	5ms (max.)
	Power Consumption	PS-3650A:110VA (100W) (max.) PS3651A:95VA (50W) (max.)	PS-3650A:80W or less PS-3651A:40W or less
	In-Rush Current	For AC100V (Ambient temperature): 30A (max.) For AC240V (Ambient temperature): 50A (max.)	30A (max.) (Ambient Temperature)
Voltage Endurance		AC1500V 20mA for 1 minute (between charging and FG terminals)	AC1000V 20mA for 1 minute (between charging and FG terminals)
Insulation Resistance		DC500V 10M Ω (min.) (between charging and FG terminals)	

2.1.2 Environmental

		PS-3650A	PS-3651A
Physical	Surrounding Air Temperature	0°C to 50°C HDD: 5 to 50°C	0°C to 50°C HDD: 5 to 45°C
	Storage Temperature	-20 to +60°C	
	Ambient Humidity	10%RH to 90%RH (Not condensing, wet bulb temperature: 39°C or less. Wet bulb temperature with HDD: 29°C or less.)	
	Storage Humidity	10%RH to 90%RH (Not condensing, wet bulb temperature: 39°C or less.)	
	Dust	Free of dust	
	Pollution Degree	For use in Pollution Degree 2 environment	
	Corrosive gas	Free of corrosive gas	
	Atmosphere (Using height)	800 to 1114hPa (-300 to 2000m)	
Mechanical	Vibration Resistance	<When not using HDD> IEC61131-2 compliant 5Hz to 9Hz single-amplitude 3.5mm [0.14 in.] 9Hz to 150Hz constant-accelerated velocity 9.8m/s ² X, Y, Z directions 10 cycle (100 minutes) <When using HDD> 4.9m/s ² 10Hz to 25Hz X, Y, Z directions (30min. each)	

Electrical	Noise Immunity (via noise simulator)	AC type	Noise Voltage: 1,500Vp-p (via noise simulator) Pulse Duration: 50ns, 500ns, 1 μ s Rise Time: 1ns
		DC type	Noise Voltage: 1,000Vp-p (via noise simulator) Pulse Duration: 50ns, 500ns, 1 μ s Rise Time: 1ns
	Electrostatic Discharge Immunity	6kV (complies with IEC61000-4-2 Level 3)	
Noise Immunity (Fast Transient Burst Noise)		Power supply line : 2kV (IEC61000-4-4) COM port: 1kV (IEC61000-4-4)	

IMPORTANT

- When using any of the PS-A's optional devices, be sure to check that device's specifications for any special conditions or cautions that may apply to its use.

2.1.3 Structural

		PS-3650A	PS-3651A
Installation	Grounding	Grounding resistance of 100 Ω , 2mm ² or thicker wire, or your country's applicable standard. (Same for FG and SG terminals)	
	Structure	Rating ^{*1} : Equivalent to IP65f (Only not using Front USB) figuration: Built-in type Installation method: Embedding	
	Cooling Method	Forced cooling by fan	Natural air circulation
	Weight	Approx. 4.5kg [9.9lb] (unit only)	Approx. 3.8kg [8.4lb] (unit only)
	External Dimensions	W313mm [12.32in.] × H239mm [9.41in.] × D103mm [4.06in.]	W313mm [12.32in.] × H239mm [9.41in.] × D60mm [2.36in.]

*1 The front face of the PS-A unit, installed in a solid panel, has been tested using conditions equivalent to the standards shown in the specification. Even though the PS-A unit's level of resistance is equivalent to these standards, oils that should have no effect on the PS-A can possibly harm the unit. This can occur in areas where either vaporized oils are present, or where low viscosity cutting oils are allowed to adhere to the unit for long periods of time. If the PS-A's front face protection sheet becomes peeled off, these conditions can lead to the ingress of oil into the PS-A and separate protection measures are suggested. Also, if non-approved oils are present, it may cause deformation or corrosion of the front panel's plastic cover. Therefore, prior to installing the PS-A be sure to confirm the type of conditions that will be present in the PS-A's operating environment.

If the installation gasket is used for a long period of time, or if the unit and its gasket are removed from the panel, the original level of the protection cannot be guaranteed. To maintain the original protection level, be sure to replace the installation gasket regularly.

2.2 Performance Specifications

2.2.1 Performance Specifications

		PS-3650A	PS-3651A
CPU		Intel Celeron M320 (1.3GHz)	Intel ULV CeleronM (600MHz)
L2 Cache Memory		512KB (Built in the CPU)	
Main Memory		S.O DIMM socket 256 to 1GB (PC2700)	
BIOS		FirstBIOS Embedded Pro (Phoenix Technologies Co.)	
Graphics		XGA (1024 × 768 dots)	
Video Memory		8 to 64MB (UMA method)	
Interface	Serial Interface	COM1: RS-232C Corresponding to IEA-232 Connector: D-SUB 9 pin (plug) (5V/RI switching available)	
	Network Interface	Ethernet 2 ports (Corresponding to IEEE802.3, 10BASE-T/100BASE-TX automatic switching SIDE) Connector: Modular Jack (RJ-45)	
	USB Interface	Front face: USB 1.1 (Low/ Full Speed 12 Mbps) × 1 port Side face: USB 2.0 (High Speed 480 Mbps) × 4 ports Connector: USB TYPE-A Power supply voltage: 5V DC ±5% Output current : Each port: 500mA (max.), Total 5 ports (Front and Left): 500mA (max.) The maximum communication distance: 5m	
	RAS Interface	General Input 2ch (DIN1 can be used as Reset Input), General Output 2ch Connector: D-SUB 9 pin (socket)	
	Speaker Output Interface	Stereo Speaker output Connector: Mini Pin Jack	
	IDE	Ultra ATA100 Primary Master: 2.5 inch HD slot Primary Slave: CF card slot (Type II)	
	PCMCIA	Corresponding to CARD BUS (Excluding ZOOM VIDEO, SOUND functions)	
	PCI	PCI Rev. 2.2 (33MHz)	None
Clock Accuracy *1		± 180 sec. / month (timing error depending on the situation at normal temperature and power-off)	

*1 The RTC clock built in the PS-A has a timing error. The range of the error will be between +300 ~ -300 sec. / month, depending on the PS-A's conditions such as lifetime usage or temperature difference. If you use the PS-A in a system that is very dependent on timing, adjust the clock in regular intervals.

2.2.2 Display

Type	TFT Color LCD
Resolution	W1,024 x H768 pixels
Dot pitch	W0.24mm [0.01in.] x H0.24mm [0.01in.]
Effective Display Area	W245.76mm [9.68in.] x H184.32mm [7.26in.]
Color/Shade level	262,144 colors
Backlight	CFL (user replaceable)
Brightness control	4 levels of adjustment
Contrast Adjustment	None
View Angles	Horizontal Direction : 120 degrees, Vertical Direction: 100 degrees (Contrast ratio: CR is 10 or greater, or TYP value)
Display Service Life	50,000hrs. (at 25°C and 65%RH (humidity))
Backlight Service Life	50,000hrs. or more (at ambient temperature 25°C and continuous operation - period until backlight brightness decreases to 50% or backlight starts to flicker)

2.2.3 Touch Panel

Type	Resistive Film (analog)
Resolution	1024 x 1024
Service Life	1,000,000 times or more, Sweeping 100,000 times or more

2.2.4 Expansion Slot

Slot Type	PCI 2.2 (5V)			
Size	174.63mm [6.88in.] × 106.68mm [4.20in.]			
Output Voltage	DC5V	DC12V	DC-12V	DC3.3V
consumption current	1.5A	0.5A	0.1A	0.5A

2.3 Interface Specifications

This section describes the specifications of each interface of the PS-A Series unit.

IMPORTANT

- The PS-A unit's serial port is not isolated. When the host (PLC) unit is also not isolated, be sure to connect the #5 SG (Signal Ground) terminal to reduce the risk of damaging the RS-232C circuit.
- Inside the PS-A unit, the SG (Signal Ground) and FG (Frame Ground) terminals are connected.
- When connecting an external device to the PS-A using the SG terminal, be sure to check that no short-circuit loop is created when you setup the system.

2.3.1 Serial Interfaces (COM1)

This interface is used to connect an RS-232C (serial) cable. A D-sub 9-pin plug connector is used.

Use #4-40 (UNC) fixing clamps to fix the joint of the interspace.

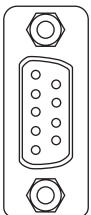
Pin Arrangement	Pin No.	Signal Name	Direction	Meaning
	1	CD	Input	Carrier Detect
	2	RD(RXD)	Input	Receive Data
	3	SD(TXD)	Output	Send Data
	4	ER(DTR)	Output	Data Terminal Ready
	5	SG	-	Signal Ground
	6	DR(DSR)	Input	Data Set Ready
	7	RS(RTS)	Output	Request to Send
	8	CS(CTS)	Input	Send Possible
	9	CI(RI)/5V	Input	Called status display/+5V Output (Switching available ^{*1})
	Shell	FG	-	Frame Ground (Common with SG)

*1 By the switch on the board of the inside of the unit, it is available to change RI/5V.

■ Switch

The RI/5V change switch, corresponding to serial interface, is placed on the board which you opened the fan cover or the memory slot cover. Refer to the following for more details of how to remove the fan cover or the memory slot cover.

SEE → 3.3.1 Main Memory Installation (page3-13)

IMPORTANT

- When you switch RI/5V, you must turn off the power supply for PS-A. Otherwise, it will cause malfunction.
- Prior to the switching action, confirm the interface specification for the other side of the connection. Otherwise, it will cause malfunction.

<Magnified image>

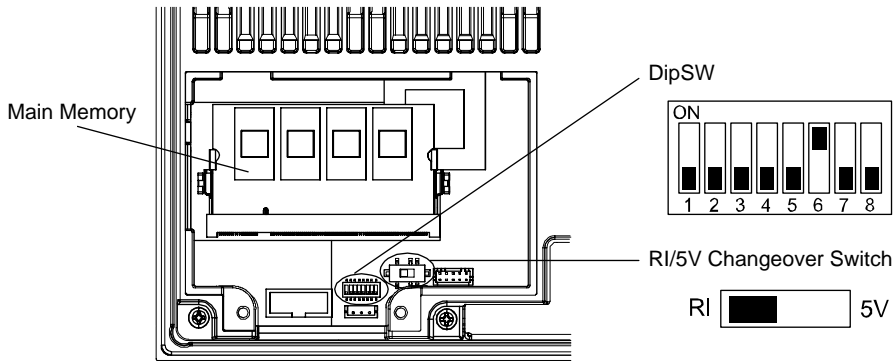

<RI/5V change switch>

The switch can change “RI/5V” for the No.9 pin of a RS-232C. The factory setting is “RI”.

<Dip SW>

SW No.	Meaning	ON	OFF	Notes
1	Used for the system.	Reserved	Reserved	The factory setting is “OFF”.
2				
3				
4	Able to set up an enabled/disabled state for the hardware reset switch.*1	Disabled	Enabled	The factory setting is “OFF”.
5	Used for the system.	Reserved	Reserved	The factory setting is “OFF”.
6	Able to set up an enabled/disabled state for the front USB.*2 *3	Enabled	Disabled	The factory setting is “ON”.
7	Able to change a Master/Slave setting for CF card slot.	Master	Slave	The factory setting is “OFF”.*4
8	Used for the system.	Reserved	Reserved	The factory setting is “OFF”.

*1 When selected “disabled”, it is impossible to reset the system while the system is running. However it is possible to enter the reset switch while the system is NOT running (Soft OFF state). See the following for the Soft OFF State:

SEE → 1.1.2 Power Supply (page1-3)

*2 When selected “disabled”, the front USB cannot be used after you turn on the power of the PS-A.

*3 The front USB port is available for only Windows® 2000 and Windows® XP. Make sure to disable the function of the setting when other OS used.

*4 When built in Pro-face’s Windows® XP Embedded, the factory setting is ON.

2.3.2 RAS Interface

Types of sockets for D-sub 9 pins are listed below.

Use #4-40 (UNC) fixing clamps to fix the joint of the interspace.

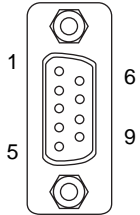
Pin Arrangement	Pin No.	Signal Name	Meaning
	1	+12V	Output Current:100mA or less Output Voltage: DC12V±5%
	2	DOUT 0 (+)	Data Output 0(+)
	3	DOUT 1 (+)	Data Output 1(+)
	4	DIN 0(+)	Data Input 0 (+)
	5	DIN 1(+)	Data Input 1 (+) ^{*1}
	6	GND	SG (same as FG)
	7	DOUT 0 (-)	Data Output 0 (-)
	8	DOUT 1 (-)	Data Output 1 (-)
	9	DINCOM	DIN GND Common

*1 DIN1(+) can be used as Remote Reset Input of RAS feature. The factory setting is General Purpose Signal Input.

■ General Input (DIN 0, 1)

INPUT VOLTAGE RANGE	DC12V to 24V
INPUT CURRENT	Below 10mA
INNER RESISTOR	3.6KΩ
INSULATION VOLTAGE	AC500V or more
INSULATION	Photocoupler

■ General Output (DOUT 0, 1)

OUTPUT VOLTAGE RANGE	DC24V
OUTPUT CURRENT	Below 120mA
INSULATION VOLTAGE	AC500V or more
INSULATION	Photocoupler

NOTE

- For the circuit diagram, refer to "6.1.1 RAS Features".

2.4 Dimensions

The following dimensions apply to PS-3650A/PS-3651A units.
 (This figure shows an AC type. DC type has same dimensions.)

2.4.1 PS-3650A External Dimensions

Unit: mm [in.]

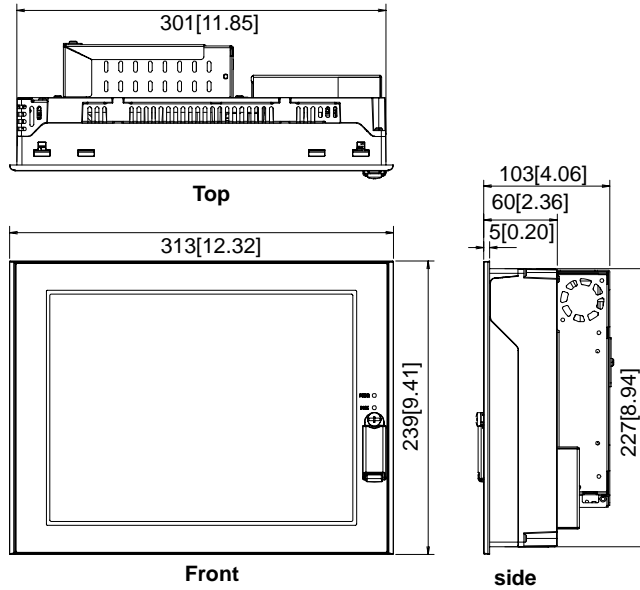

■ Dimensions with installation fasteners

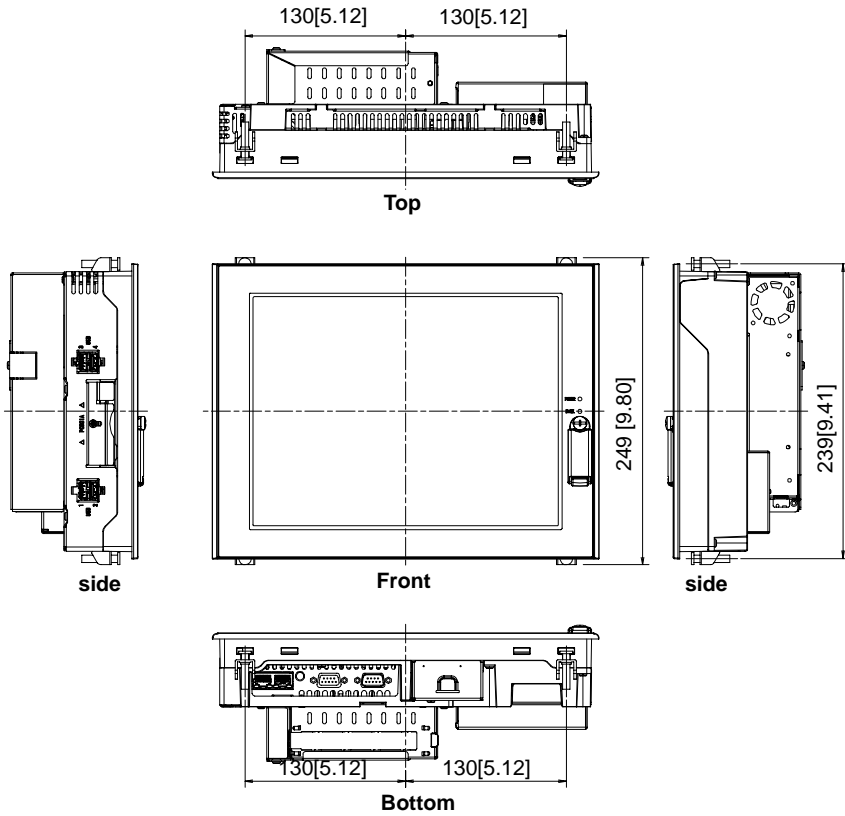

2.4.2 PS-3651A External Dimensions

Unit: mm [in.]

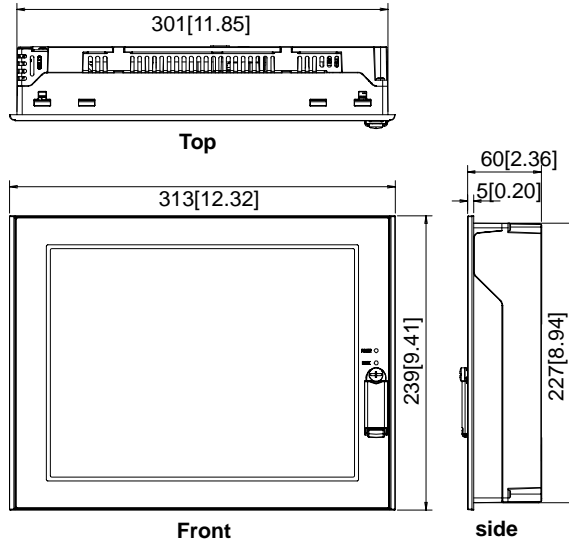

■ Dimensions with installation fasteners

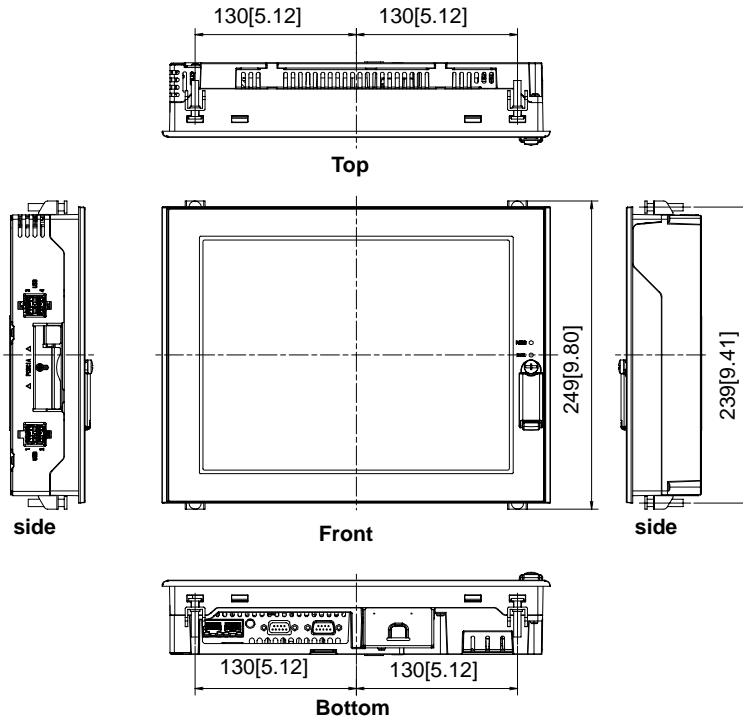

2.4.3 Panel Cut Dimensions

Panel cut dimensions for both PS-3650A and PS-3651A are the same.

Unit: mm [in.]

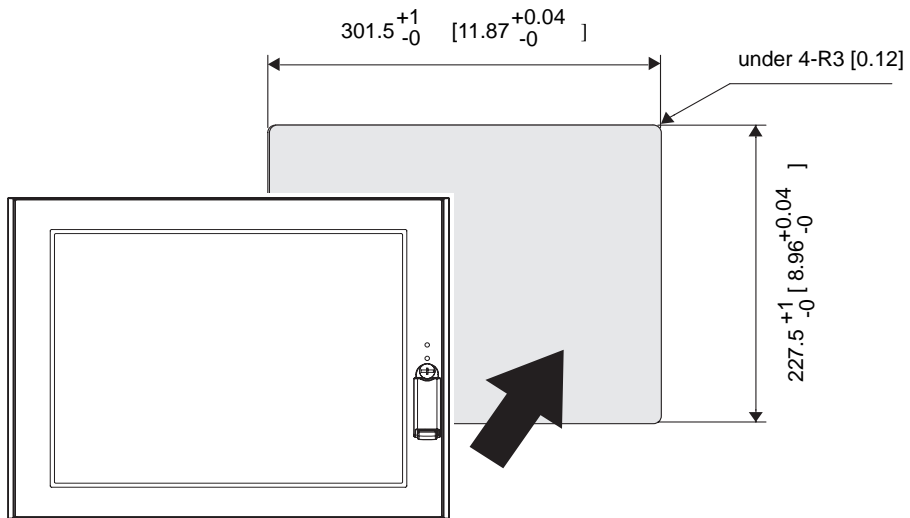

2.4.4 Installation Fasteners

Unit: mm [in.]

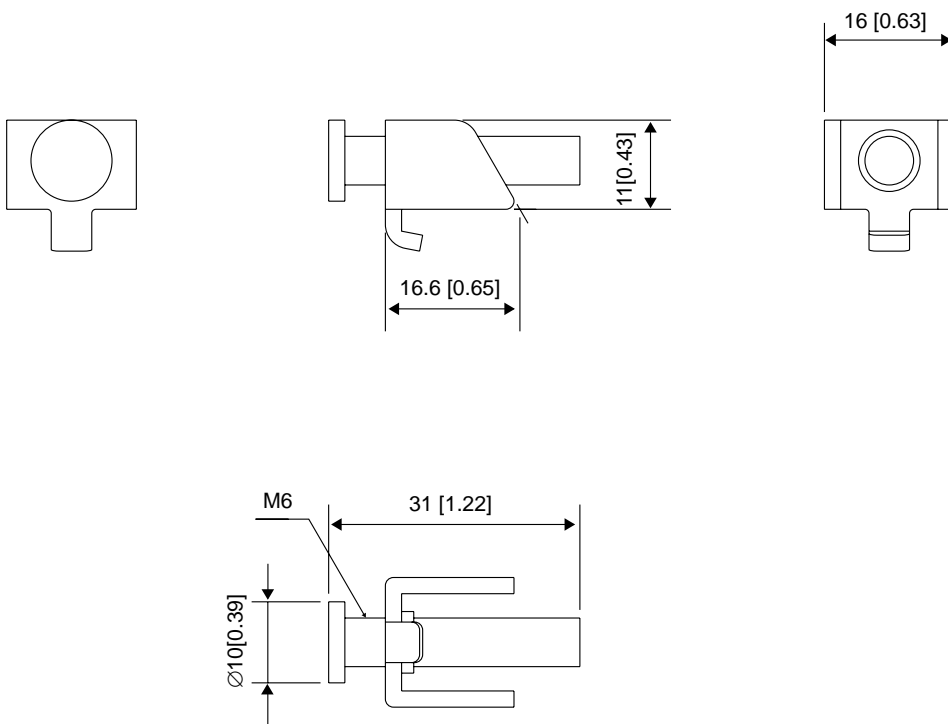

2.4.5 Dimensions attached RS-232C/RS-485 exchangeable unit

■ PS-3650A

Unit: mm [in.] (Except for protrudent objects and cable parts)

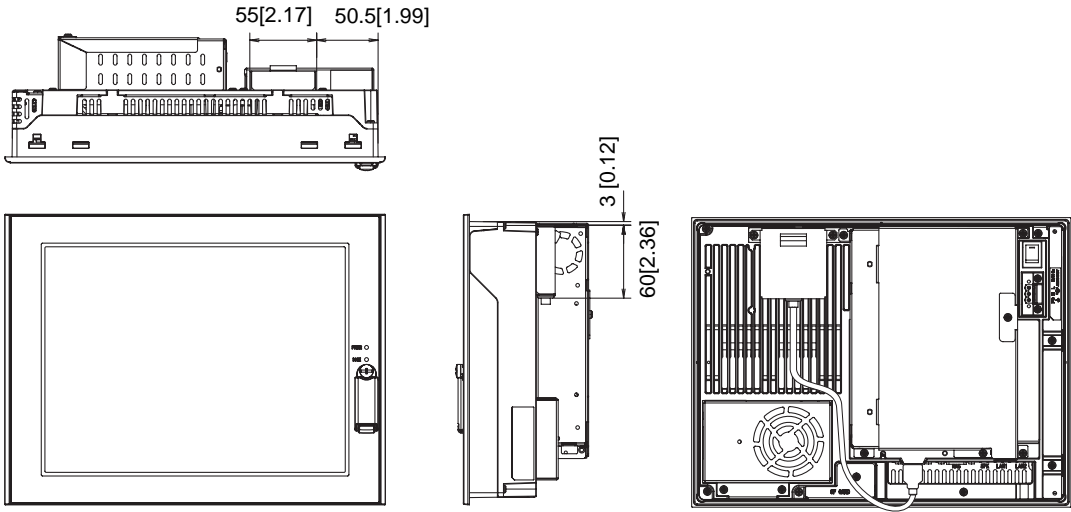

■ PS-3651A

Unit: mm [in.] (Except for protrudent objects and cable parts)

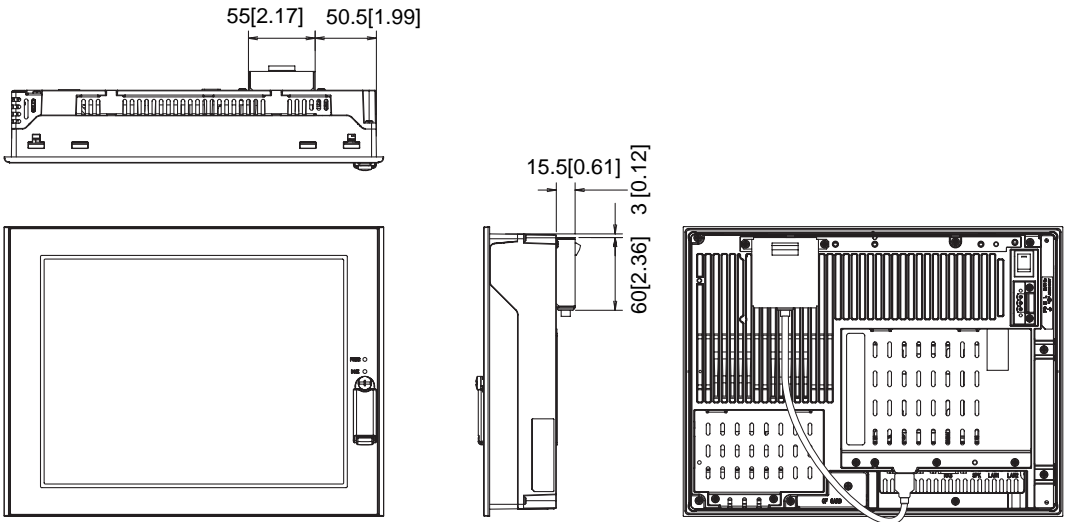

3



Hardware Installation

1. Installation
2. Wiring Precautions
3. Peripheral Devices Installation

3.1 Installation

This section describes the procedures and precautions for installing the PS-A unit.

3.1.1 Installation Procedures

Follow the steps given below when installing the PS-A.

■ Check the Installation Gasket's Seating

It is strongly recommended that you use the installation gasket, since it absorbs vibration in addition to repelling water.

For the procedure for attaching the installation gasket, refer to the following.

SEE → *7.4 Replacing the Installation Gasket (page7-6)*

IMPORTANT

- Before installing the PS-A into a cabinet or panel, check that the installation gasket is securely attached to the unit.
- A gasket which has been used for a long period of time may have scratches or dirt on it, and could have lost much of its dust and drip resistance. Be sure to change the gasket periodically (or when scratches or dirt become visible).

■ Creating a Panel Cut

Create the correct sized opening required to install the PS-A, using the installation dimensions given.

The installation gasket and the installation fasteners are required when installing the PS-A.

SEE → 2.4.3 Panel Cut Dimensions (page 2-13)

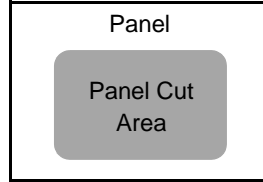

NOTE

- Check that the installation panel or cabinet's surface is flat, in good condition and has no jagged edges. Also, if desired, metal reinforcing strips can be attached to the inside of the panel, near the Panel Cut, to increase the panel's strength.

IMPORTANT

- Panel thickness should be from 1.6mm [0.06 in.] to 10.0mm [0.39 in.]. Decide the panel's thickness based on the level of panel strength required.

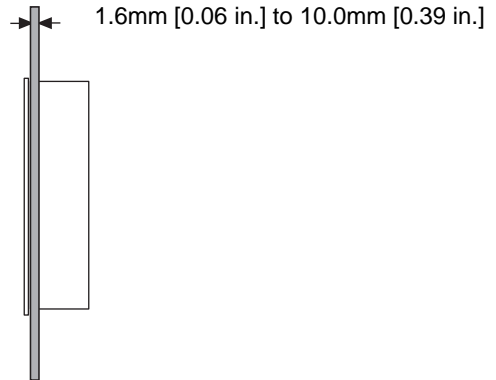

- For easier maintenance, operation, and improved ventilation, be sure to install the PS-A at least 50 mm [1.97 in.] away from adjacent structures and other equipment.

Unit: mm [in.]

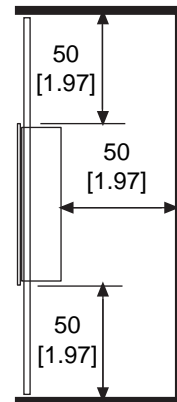
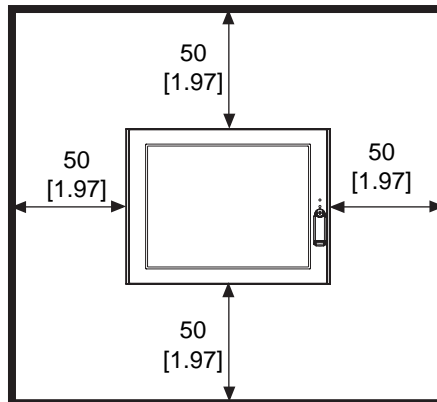

IMPORTANT

- Be sure that the ambient operation temperature and the ambient humidity are within their designated ranges. When installing the PS-A on the panel of a cabinet or enclosure, "Ambient operation temperature" indicates both the panel face and cabinet or enclosure's internal temperature.

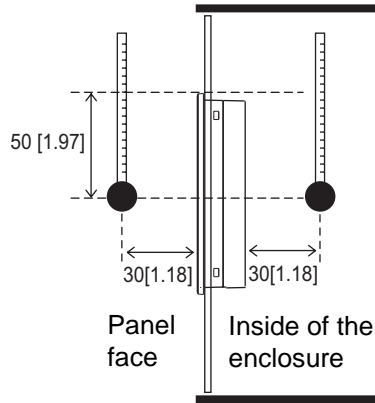

Unit: mm [in.]

- Be sure that heat from surrounding equipment does not cause the PS-A to exceed its standard operating temperature.
- When installing the PS-A in a slanted panel, the panel face should not incline more than 30°.

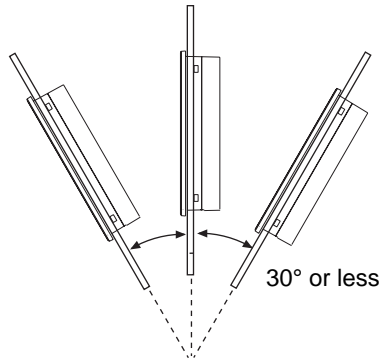

- When installing the PS-A in a slanted panel, and the panel face inclines more than 30°, the ambient temperature must not exceed 40°C. You may need to use forced air cooling (fan, A/C) to ensure the ambient operating temperature is 40°C or below.
- The PS-A Series unit does not support longitudinal mounting.

■ Installing the PS-A

- (1) Insert the PS-A into the panel cut, as shown.

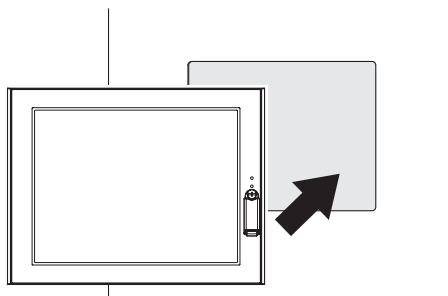

- (2) Insert the installation fasteners into the PS-A insertion slots, at the top and bottom of the unit. (total: 4 slots)

IMPORTANT

- Insert each installation fastener securely into the slot's recess (shaded area).

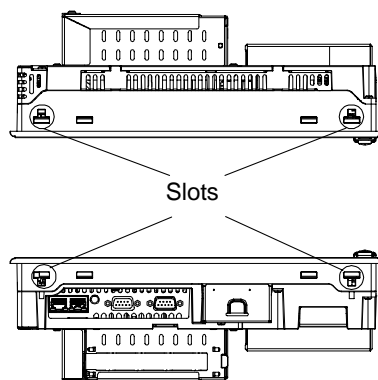
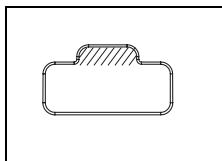

- (3) Insert each of the fasteners shown below. Be sure to pull the fastener back until it is flush with the rear of the attachment hole.

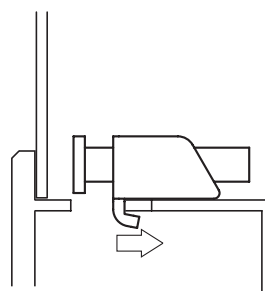
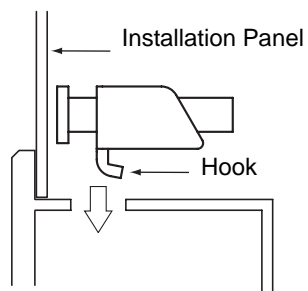

- (4) Use a Phillips screwdriver to tighten each fastener screw and secure the PS-A in place.

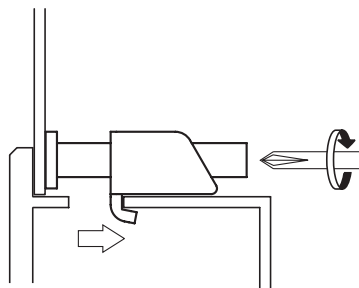

IMPORTANT





- Tightening the screws with too much force can damage the PS-A unit's plastic case.
- For the moisture resistance effect, the torque required to tighten these screws is 0.5 N•m.

3.2 Wiring Precautions

This section describes the procedures and precautions for wiring power cords.

3.2.1 Connecting the Power Cord

WARNING

-  To avoid an electric shock, prior to connecting the PS-A unit's power cord terminals to the power terminal block, confirm that the PS-A unit's power supply is completely turned OFF, via a breaker, or similar unit.
-  Supplying a power voltage other than that specified will damage the power source and the PS-A unit.
-  Since there is no power switch on PS3650A-T41-24V/PS3651A-T41-24V, be sure to attach a breaker-type switch to the power cord.
-  When the FG terminal is connected, be sure the wire is grounded.

IMPORTANT

- When the FG terminal is connected, be sure the wire is grounded. Not grounding the PS-A unit will result in excess noise and vibration.
- The SG and FG terminals are connected internally in the PS-A unit.
When connecting the SG wire to another device, be sure that the design of the system/connection does not produce a shorting loop.

■ AC Connections

WARNING

-  The PS-A units is designed to use AC100V to AC240V input. Supplying a power voltage other than that specified will damage the power source and the PS-A unit.

IMPORTANT

- The power cord included in the package, is designed only for AC100V use.
Under other voltage situation, you should use a different cord in conformity with the voltage.

Power Cord Specifications

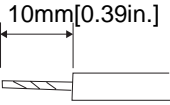
Power Cord Diameter	0.75 to 2.5mm ² (18 to 12 AWG)
Conductor Type	Simple or Stranded Wire ^{*1}
Conductor Length	

*1 If the Conductor's end (individual) wires are not twisted correctly, the end wires may either short against each other, or against an electrode.

IMPORTANT

- Use copper conductors only.

Wiring

When connecting the power cord, use the following items when performing wiring. (Items are made by Phoenix Contact.^{*1})

Recommended Driver	SZS 0.6x3.5 (1205053)
Recommended Pin Terminals	AI 0.75-10GY (3201288) AI 1-10RD (3200182) AI 1.5-10BK (3200195) AI 2.5-12BU (3200962)
Recommended Pin Terminal Crimp Tool	CRIMPFOX ZA3 (1201882)

NOTE

- The power supply connector (plug) is CA7-ACCNL-01 (made by Pro-face) or FKC2.5/3-STF-5.08 (made by Phoenix Contact^{*1}).

*1 For details, please contact your local Phoenix Contact distributor.

Connecting the Power Cord

- (1) Confirm that the power is not supplied to the PS-A unit.
- (2) Unplug the power connector from the rear of the PS-A unit.
- (3) Push the Opening button with a small and flat screw driver to open the desired pin hole.

- (4) Insert each pin terminal into its each hole. Release the Opening button to clamp the pin place.

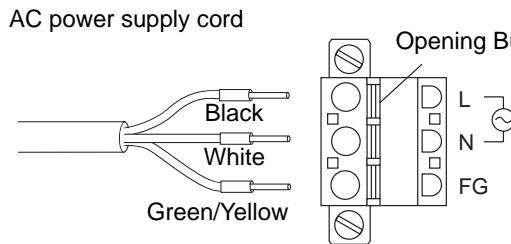

- (5) After inserting all three pins, insert the Power Plug into the Power Connector at PS-A. Fix the plug with two (2) minus screws.

IMPORTANT

- Confirm that all wires are connected correctly.
- The torque required to tighten these screws is 0.5 to 0.6N•m.
- To prevent the possibility of a terminal short, use a pin terminal that has an insulating sleeve.

■ DC Connections

Power Cord Specifications

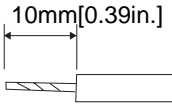
Power Cord Diameter	0.75 to 2.5mm ² (18 to 12 AWG)
Conductor Type	Simple or Stranded Wire ^{*1}
Conductor Length	10mm[0.39in.] 

- *1 If the Conductor's end (individual) wires are not twisted correctly, the end wires may either short against each other, or against an electrode.

IMPORTANT

- Use copper conductors only.

Wiring

When connecting the power cord, use the following items when performing wiring. (Items are made by Phoenix Contact.^{*1)})

Recommended Driver	SZS 0.6x3.5 (1205053)
Recommended Pin Terminals	AI 0.75-10GY (3201288) AI 1-10RD (3200182) AI 1.5-10BK (3200195) AI 2.5-12BU (3200962)
Recommended Pin Terminal Crimp Tool	CRIMPFOX ZA3 (1201882)

NOTE

- The power supply connector (plug) is CA7-DCCNL-01 (made by Pro-face) or GFKC2,5/3-STF-7,62 (made by Phoenix Contact^{*1)}).

*1 For details, please contact your local Phoenix Contact distributor.

Connecting the Power Cord

- Confirm that the power is not supplied to the PS-A unit.
- Unplug the power connector from the rear of the PS-A unit.
- Push the Opening button with a small and flat screw driver to open the desired pin hole.
- Insert each pin terminal into its hole. Release the Opening button to clamp the pin in place.

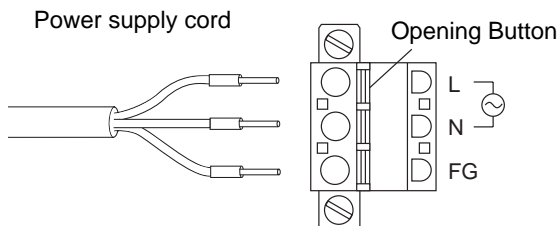

- After inserting all three pins, insert the Power Plug into the Power Connector at PS-A. Fix the plug with two (2) slot screws.

IMPORTANT

- The torque required to tighten these screws is 0.5 to 0.6N•m.
- To prevent the possibility of a terminal short, use a pin terminal that has an insulating sleeve.

3.2.2 Connecting the Power Supply

This section describes the precautions for supplying a power voltage.

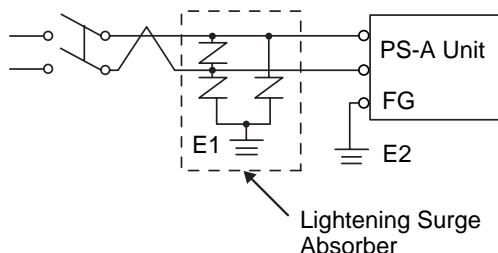
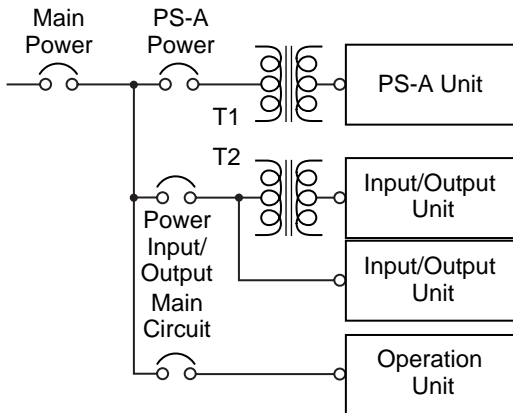
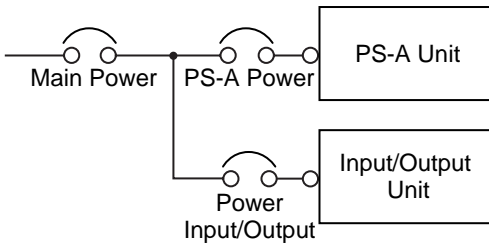
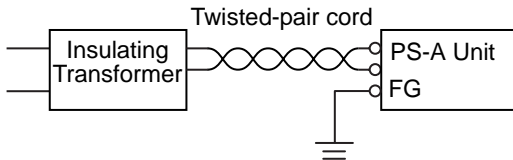
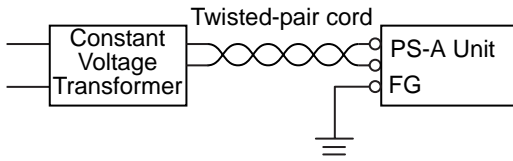

- If the supplied voltage exceeds the PS-A unit's range, connect a constant voltage transformer.

SEE → 2.1.1 Electrical (page2-2)

- For between the line and ground or between the lines, select a power supply that is low in noise. If there is an excess amount of noise, connect an insulating transformer.

IMPORTANT

- Use constant voltage and insulating transformers with capacities of 200VA or more.
- When supplying power to the PS-A unit, please separate the input/output and operation unit lines, as shown.
- To increase the noise resistance quality of the power cord, it is recommended to attach a ferrite core to the power cord.
- The power supply cable must not be bundled or positioned close to main circuit lines (high voltage, high current), or input/output signal lines.
- Connect a lightning surge absorber, as shown in the diagram, to deal with power surges.
- To avoid excess noise, make the power cord as short as possible.

IMPORTANT

- Be sure to ground the surge absorber (E1) separately from the PS-A unit (E2).
- Select a surge absorber that has a maximum circuit voltage greater than that of the peak voltage of the power supply.

3.2.3 Grounding

This section describes the precautions for grounding the PS-A unit.

⚠ CAUTION

❗ Do not use common grounding, since it can lead to an accident or machine breakdown.

(a) Exclusive Grounding (BEST)

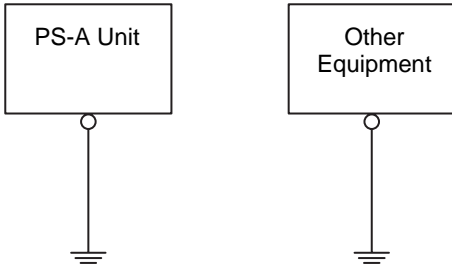

- When supplying power to the PS-A unit, be sure to separate the input/output and power lines, as shown. [diagram (a)]

IMPORTANT

- Check that the grounding resistance is 100Ω or less.
- FG and SG terminals are internally connected in the PS-A. When connecting an external device to the PS-A using the SG terminal, be sure to check that no short-circuit loop is created when you setup the system.
- The grounding wire should have a cross sectional area of 2mm² or greater. Create the connection point as close to the PS-A unit as possible, and make the wire as short, as possible. When using a long grounding wire, replace the thin wire with a thicker wire, and place it in a duct.

(b) Common Grounding (OK)

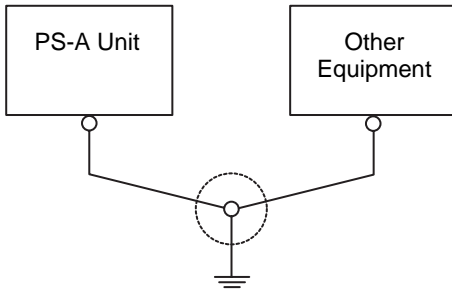

(c) Common Grounding (Not OK)

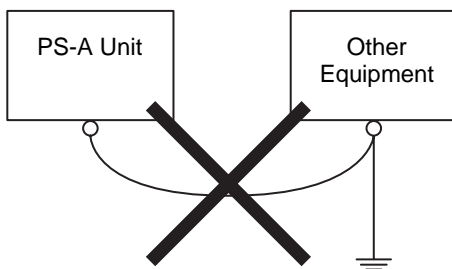

- If exclusive grounding is not possible, use a common connection point. [diagram (b)]

NOTE

- If the equipment does not function properly when grounded, disconnect the ground wire from the FG terminal.

3.2.4 I/O Signal Line Placement

- Input and output signal lines must be separated from the power control cables for operating circuits.
- If this is not possible, use a shielded cable and ground the edge of the shield.

3.3 Peripheral Devices Installation

A wide variety of optional units, DIM module, CF cards, manufactured by Pro-face and commercial Expansion boards (PCI bus compatible board), PCMCIA (PC cards) can be used with the PS-A. (Expansion boards are used only for PS-3650A.)

When installing the optional units, refer to each unit's "Installation Guide".

⚠ WARNING

- ⊘ Be sure to confirm that power is not supplied to the PS-A unit before installing or removing any optional units, DIM module, CF cards, or Expansion boards (PCI boards). Failure to do so can result in an electric shock.

IMPORTANT

- If the PS-A unit is in the Soft OFF Status, power is supplied to a part of circuits even when no screen is displayed. Be sure to confirm that a power cable is not connected before installing or removing peripheral equipment.
- Use a screwdriver to loosen or tighten the screws. Be sure not to tighten screws too tightly, since it may damage the unit.
- When removing or replacing screws, be careful that they do not fall inside the PS-A unit's chassis.
- When installing the PS-A unit, or when attaching an optional item to the PS-A unit, do not hold the PS-A unit's rear-face fan cover while performing the work. Doing so may damage the fan cover or cause the cover to fall off.

3.3.1 Main Memory Installation

■ PS-3650A

- (1) Turn OFF the power switch of the PS-A and remove the power cable. Place the PS-A on a flat, level surface facing the display face downwards.
- (2) Unscrew the screws (2) as you see on the following figure, then remove the cooling fan.

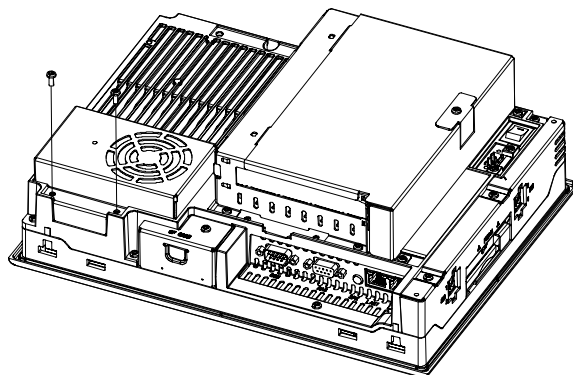

- (3) Install the main memory where the following figure shows. Insert the DIM module, which is an optional product, into the connector completely in an oblique direction, then press it downward until it is locked into the stopper.

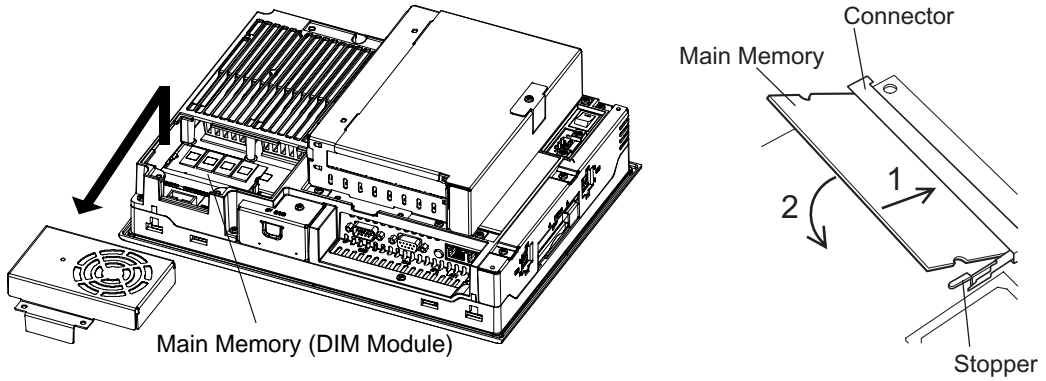

- (4) Place back the cooling fan and fix with two screws. The torque required to tighten these screws is 0.5 to 0.6N•m.

■ PS-3651A

- (1) Turn OFF the power switch of the PS-A and remove the power cable. Place the PS-A on a flat, level surface facing the display face downwards.
- (2) Unscrew the screws (2) as you see on the following figure, then remove the Memory slot cover.

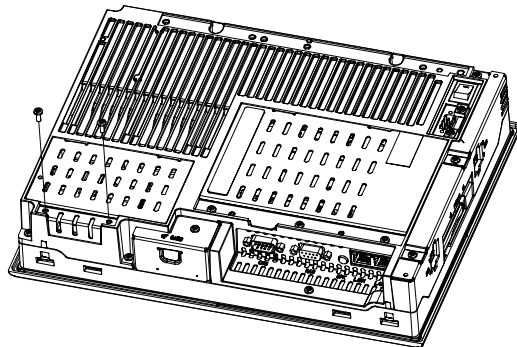

- (3) Install the main memory where the following figure shows. Insert the DIM module, which is an optional product, into the connector completely in an oblique direction, then press it downward until it is locked into the stopper.

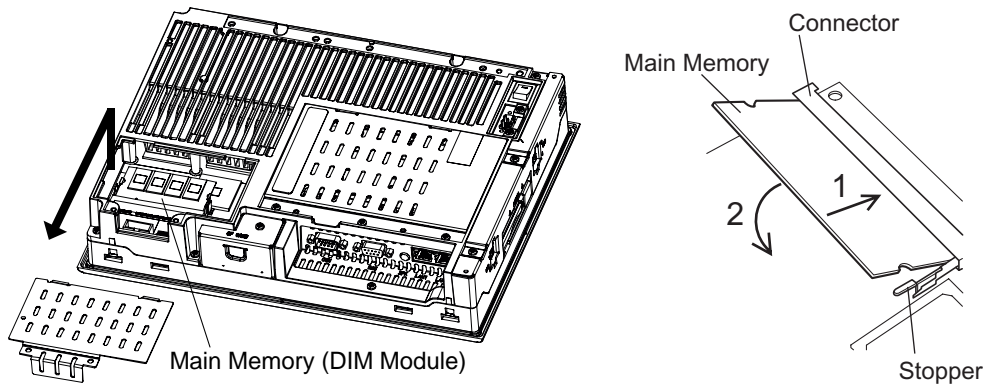

- (4) Place back the Memory slot cover and fix with two screws. The torque required to tighten these screws is 0.5 to 0.6N•m.

3.3.2 PCI Board Installation

A PCI board, which is sold on the market, can be installed on PS-3650A.

NOTE

- The maximum size allowed for a PCI board is 174.63mm [6.88in.] × 106.68mm [4.2in.].

- Turn OFF the power switch of the PS-A and remove the power cable. Place the PS-A on a flat, level surface facing the display face downwards
- Unscrew a screw of the expansion board support and remove the expansion board support.

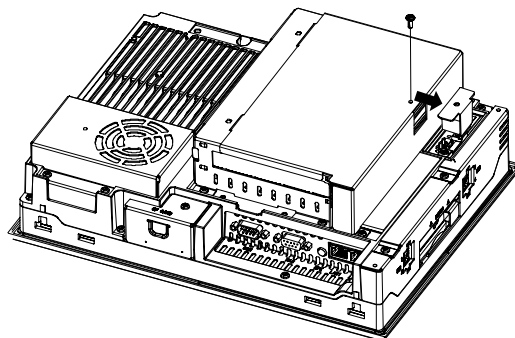

- (3) Unscrew the expansion board cover's screws (2) and remove the expansion board cover.

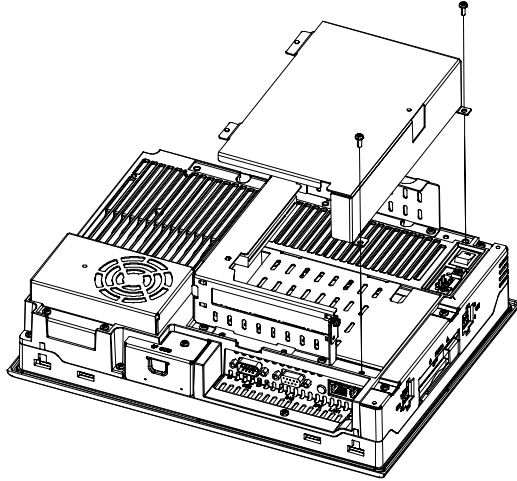

- (4) Unscrew a screw of the blank panel and take out the blank panel.
- (5) Insert the PCI board into the expansion board connector and place back the screw to fix the PCI board.
The torque required to tighten a screw is 0.5 to 0.6N•m.

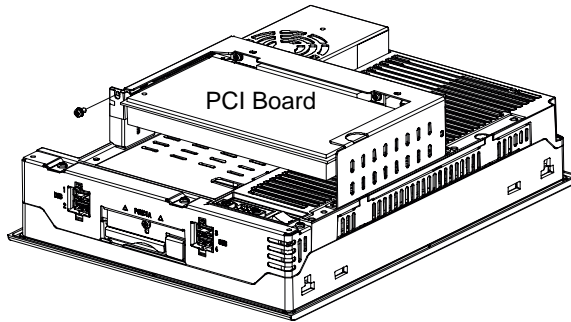

- (6) Place back both of the expansion board cover and expansion board support. The torque required to tighten each of the screws is 0.5 to 0.6N•m.

3.3.3 PCMCIA (PC Card) Installation/Removal

- (1) Slacken a screw of PCMCIA slot on the side of the PS-A unit to move the cover.

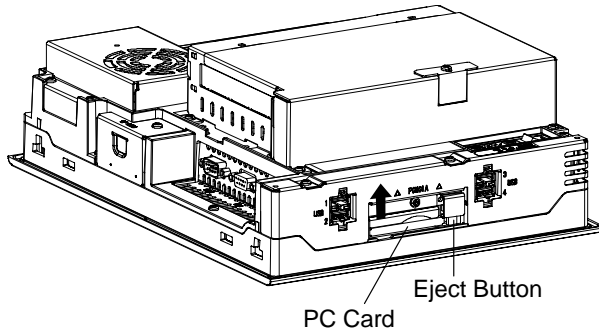

- (2) Press the eject button twice to remove the PC Card from the PCMCIA connector. (Pressing the eject button once causes its tip to come out. Pressing the eject button the second ejects the PC Card from the PCMCIA slot.)
- (3) Place back the PCMCIA slot cover and tighten a screw.

IMPORTANT

- When using a PC Card with a cable attached, Pro-face recommends you use a clamp or other type of device to prevent vibration from possibly dislodging the cable.
- When energizing to PS-A, be sure to stop the PS-A unit PC Card's driver prior to removing the PC Card. A failure to stop this driver may result in damage to either the PC Card, the PC Card's data, or may cause Windows® to hang up. For information on the procedure for stopping the PC Card's driver, please refer to your OS' User Manual.

To install a PC Card Type III, unscrew the PCMCIA slot cover's screw and remove the cover as shown below.

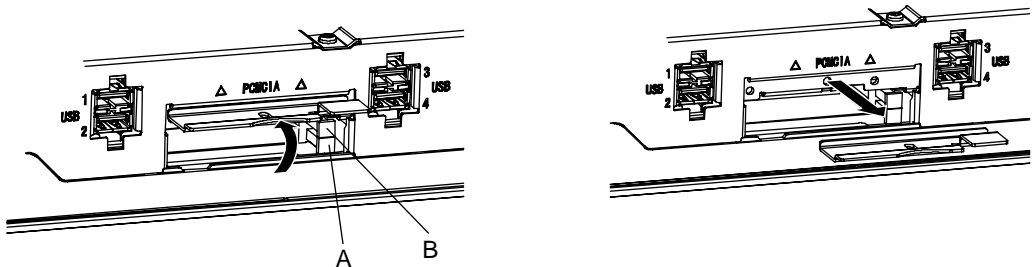







IMPORTANT

- Install the PC Card in the slot on the display side (A in the illustration). The slot on the rear side (B in the illustration) does not support a PC card.
- Please keep the removed PCMCIA slot cover and screw with care.

3.3.4 CF Card Insertion/Removal

When using the PS-A Unit and a CF Card, observe the following precautions:

CAUTION

-  Prior to inserting or removing a CF Card, be sure to confirm that the PS-A unit is turned OFF. If you do not, CF Card internal data may be damaged or lost or the OS may stop.
-  While a CF Card is being accessed (Status LED: Blinking in green), NEVER turn OFF or reset the PS-A, or insert or remove the CF Card. If you do not, CF Card internal data may be damaged or lost.
-  Prior to inserting a CF Card, familiarize yourself with the CF Card's front and rear face orientation, as well as the CF Card connector's position. If the CF Card is not correctly positioned when it is inserted into the Multi Unit, the CF Card's internal data, CF Card and the PS-A unit may be damaged or broken.
-  Be sure to use only CF Cards manufactured by the Pro-face. The CF Card's internal data may be damaged when using another manufacturer's CF Card.
-  Once PS-A data is lost, it cannot be recovered. Since accidental data loss can occur at any time, be sure to back up all PS-A screen and CF Card data regularly.
-  Be sure to follow the instructions given below to prevent the CF Card's internal data from being destroyed or a CF Card malfunction from occurring:
 - DO NOT bend the CF Card.
 - DO NOT drop or strike the CF Card against another object.
 - Keep the CF Card dry.
 - DO NOT touch the CF Card connectors.
 - DO NOT disassemble or modify the CF Card.

■ Inserting the CF Card

Use the following steps to insert the CF Card in the PS-A.

- (1) Confirm that the PS-A is turned OFF.
- (2) Slacken a screw of the CF card cover and remove the CF card cover.

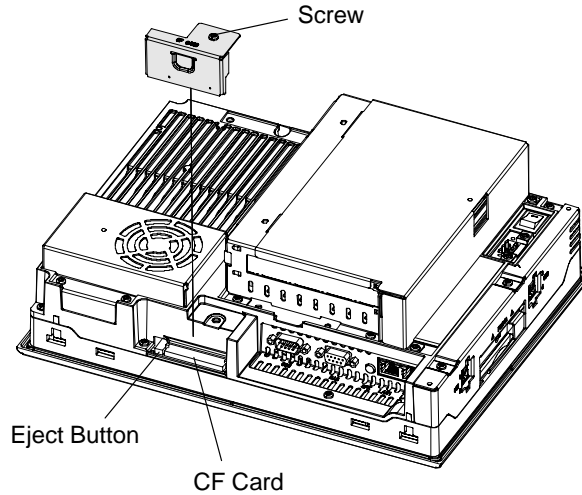

- (3) Confirm two sides of the CF card and insert the CF card in the CF card slot. Push the eject button completely until the eject button is pushed forward.
- (4) Install the CF Card cover and fix it with a screw.

NOTE

- Make sure that the CF card cover is closed when accessing the CF card.
- The torque required to tighten a screw is 0.5 to 0.6N•m.

■ Removing the CF Card

Confirm that the PS-A is turned OFF. Then, remove the CF card cover, press the eject button and carefully remove the CF card. After removing the CF card, be sure to place back the CF card cover and fix the cover with a screw.

■ Backup of CF Card

The CF Card has a data overwrite limit of approximately 100,000 times. Therefore, be sure to back up all CF card data regularly to another storage media. (100,000 times assumes the overwriting of 500KB of data in DOS format.)

< If your PC is equipped with a PC Card Slot >

- (1) Install the CF card into a CF Card Adapter (GP077-CFAD10) and insert it into a PC card slot of a personal computer.
- (2) Save the data of the CF Card with your personal computer.

3.3.5 USB Holder Attachment/Removal

When using a USB device, attaching the USB holder to the USB Interface located on the side of the PS-A unit prevents the USB cable Interface from becoming disconnected.

■ Attachment

- (1) Attach the USB holder to the USB Interface on the side of the PS-A unit.
Hook the upper pick of the USB holder to the attachment hole of the PS-A unit and then insert the lower pick as shown below to fix the USB holder.

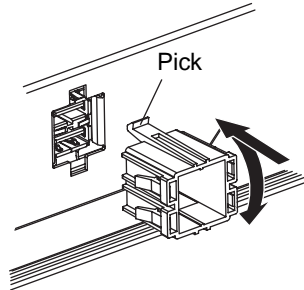

- (2) Insert the USB cable into the USB Interface.

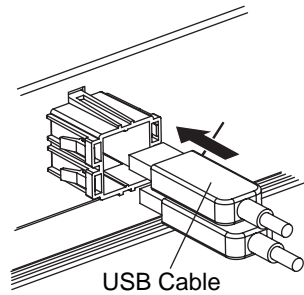

- (3) Insert the USB cover into the tab of the USB holder to fix the USB cable.

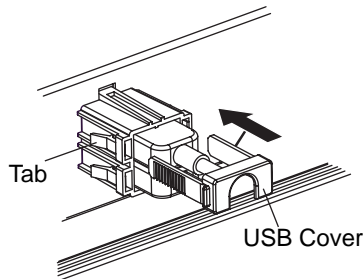

In case of installing the second USB cable, repeat the steps (2) and (3).

■ Removal

Remove USB Holder by the reverse procedures to the attachment procedures.

- (1) Lift up the tab of the USB holder and then remove the USB cover.

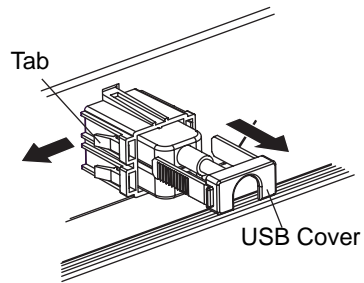

- (2) Remove the USB cable.
- (3) Remove the picks pushing the USB holder from both top and bottom and then remove the USB holder from PS-A unit.

4 | System Setup

1. Setup Procedures
2. System Parameters

This chapter explains how to enter the PS-A system settings, as well as the cautions required both before and during set up.

4.1 Setup Procedures

The BIOS setting up procedures are the following.

IMPORTANT

- Normally, use only the factory (default) settings.

- (1) Connect a USB keyboard to the PS-A.
- (2) Turn the PS-A's power ON.
- (3) After the boot-up screen comes up, press the [F2] key until the following screen appears.

Menu

PhoenixBIOS Setup - Copyright 1985-2001 Phoenix Technologies Ltd.

Main Advanced Intel Security Power Boot Exit

System Time: [10:52:03]
 System Date: [2005-12-21]

▶ Primary Master
 ▶ Primary Slave

System Memory: [XXXX KB]
 Extended Memory: [XXXX KB]

Item Specific Help

<Tab>, <Shift-Tab>, or <Enter> selects field.

F1 Help ↑ Select Item -/+ Change Values F9 Setup Defaults
 Esc Exit ↓ Select Menu Enter Select Sub-Menu F10 Previous Values

KEYBOARD ACTION KEYS
 Provides a summary of the keyboard keys used to carry out the set-up.

SYSTEM SETTING SELECTION AREA
 Each of the titles (areas) listed here contains system setting items.

Help area
 Shows the information of the items you selected.

- (4) To use the [←] [→] arrow keys, change the menu contents. A setting screen of each system will be displayed.
- (5) To use the [↑] [↓] arrow keys, move up and down the cursor to select an item of the system, then confirm it by the [Enter] key. Now you can set up the item you selected.

■ BIOS Setup Screen Configuration

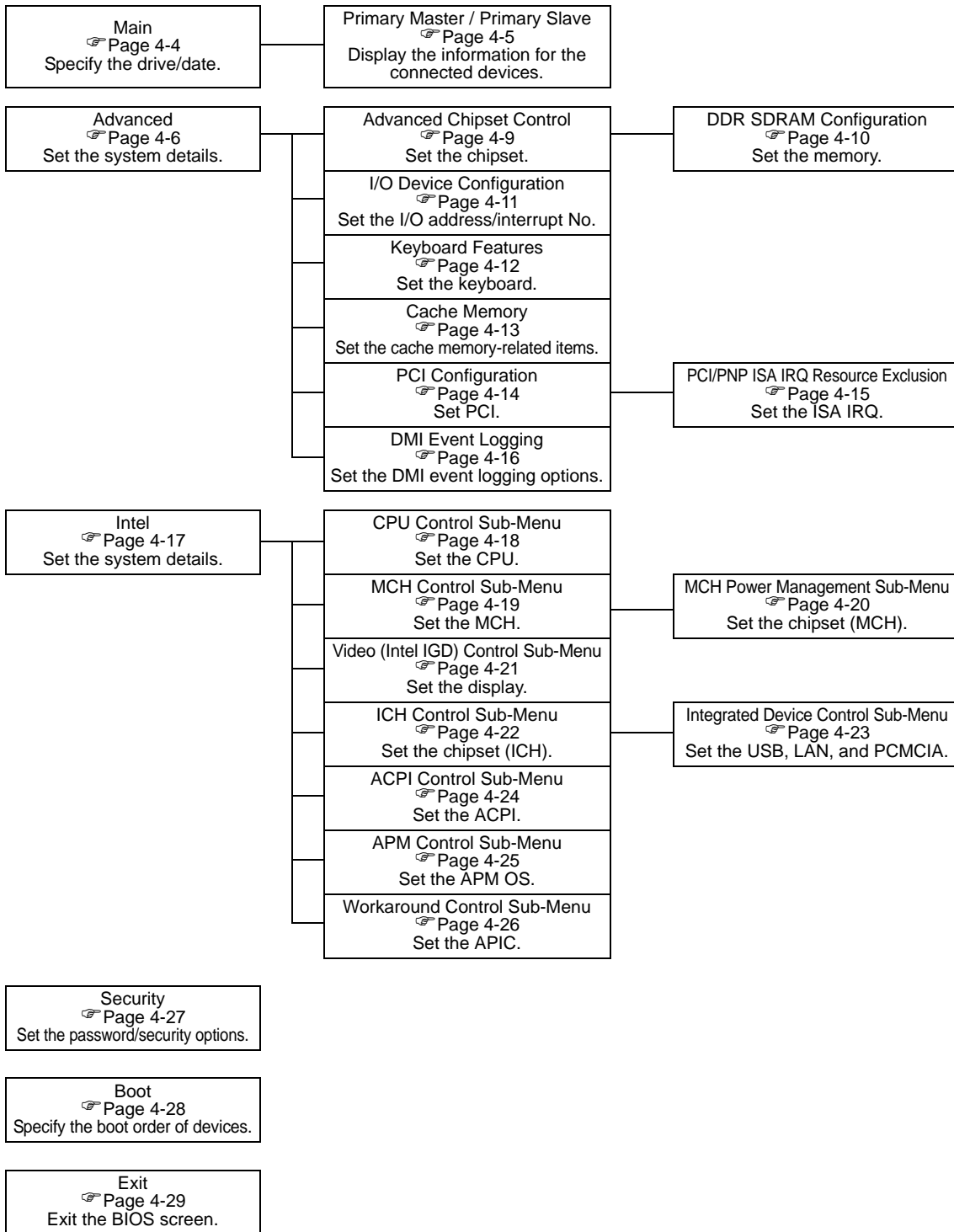

4.2 System Parameters

Select the items to set up the system information. Here, we introduce the system parameters of each item.

IMPORTANT

- Normally, use only the factory (default) settings.

4.2.1 Main

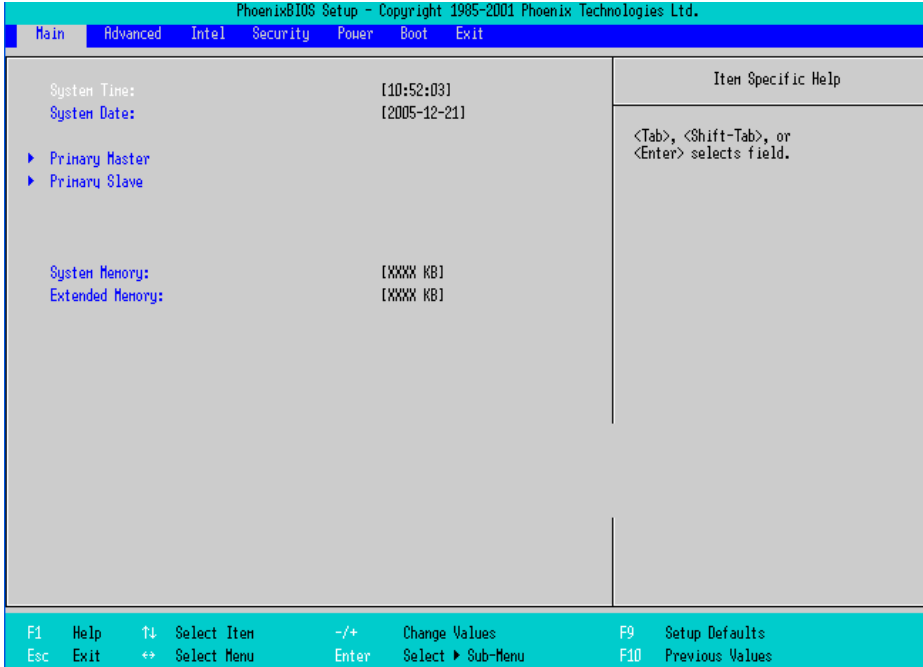

System Time

Shows the time which the PS-A currently recognizes. Move the cursor by the [Tab] key and set a proper time for the PS-A by the [Tab], [+], and [-] keys because the factory default setting is the Japan’s Standard Time (GMT+09:00).

System Date

Shows the date which the PS-A currently recognizes. Set a proper date for the PS-A by the [+], and [-] keys.

Primary Master / Primary Slave

Displays the name of devices connected to the PS-A. Pressing the [Enter] key will call up the Parameter settings menu.

SEE → ■ *Primary Master / Primary Slave (page4-5)*

System Memory

Shows the capacity of the “System Memory”.

Extended Memory

Shows the capacity of the “Extended Memory”. It is the loaded memory - the size of the Video Memory - 2048K byte.

■ Primary Master / Primary Slave

Point out the cursor at the [Primary Master] or [Primary Slave] on the “Main screen”, and then press the [Enter] key, so that the following screen is shown.

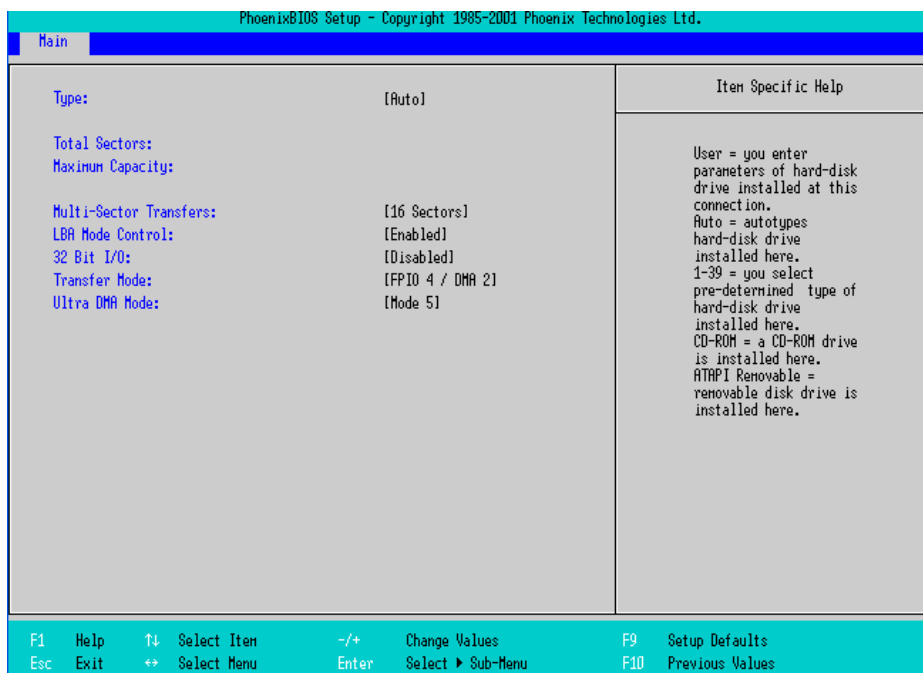

Type

Specifies a type of drive which you use. Select from [Auto], [None], [ATAPI Removable], [CD-ROM], [IDE-Removable], [Other ATAPI], or [User]. The factory default type is [Auto].

Total Sectors

Shows the number of disk sectors connected to the unit.

Maximum Capacity

Shows the maximum capacity of the disk connected to the unit.

Multi Sector Transfers

Specifies the number of sectors per block, which are transferred to the memory. When the [Type] is [None], nothing is displayed. In other cases, select from [Disabled], [2 Sectors], [4 Sectors], [8 Sectors], or [16 Sectors].

LBA Mode Control

Enables or disables the Logical Block Address (LBA) instead of the Cylinders, Headers, and Sectors. When the [Type] is [None], nothing is displayed. In other cases, select from [Disabled] or [Enabled].

32 Bit I/O

Enables or disables the 32 bit transferring between CPU and IDE controller. The choice is [Enabled] or [Disabled]. When the [Type] is [None], nothing is displayed.

Transfer Mode

Specifies a method of transferring data. When the [type] is [None], nothing is displayed. In other cases, select from [Standard], [Fast PIO 1], [Fast PIO 2], [Fast PIO 3], [Fast PIO 4], [FPIO 3/DMA 1], or [FPIO 4/DMA 2]

Ultra DMA Mode

Specifies a Ultra DMA mode for the Hard drive. When the [Type] is [None], nothing is displayed. In other cases, select from [Disabled], [Mode 0], [Mode 1], [Mode 2], [Mode 3], [Mode 4], or [Mode 5].

4.2.2 Advanced

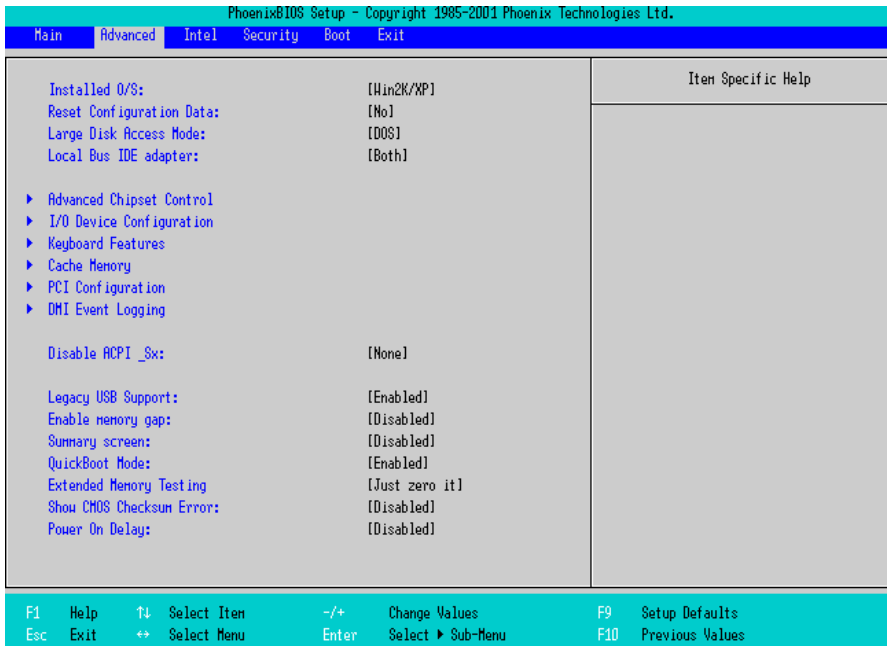

Installed O/S

Specifies a type of OS of the unit. Select from [Other], [Win95], [Win98], [WinMe], or [Win2K/XP]. The factory default setting is [Win2K/XP].

Reset Configuration Data

Specifies whether you want to reset the Plug & Play information which is recorded in the Extended System Configuration Data (ESCD) Block of the CMOS RAM, when the system boots up next time. The choice is [Yes] or [No] and the factory default setting is [No].

Large Disk Access Mode

When you use UNIX or NetWare for OS, the setting should be [Other]. The choice is [DOS] or [Other] and the factory default setting is [DOS].

Local Bus IDE adapter

Specifies an enabled/disabled state for the IDE controller. Select from [Both], [Primary], [Secondary], or [Disabled]. The the factory default setting is [Primary].

Advanced Chipset Control

Point the cursor to the [Advanced Chipset Control] and press the [Enter] Key, so that you can set up details.

SEE → ■ *Advanced Chipset Control (page4-9)*

I/O Device Configuration

Point the cursor to the [I/O Device Configuration] and press the [Enter] Key, so that you can go to the Serial Port Setting screen

SEE → ■ *I/O Device Configuration (page4-11)*

Keyboard Features

Point the cursor to the [Keyboard Features] and press the [Enter] Key, so that you can go to the keyboard set-up screen.

SEE → ■ *Keyboard Features (page4-12)*

Cache Memory

Point the cursor to the [Cache Memory] and press the [Enter] Key, so that you can go to the set-up screen for Cache Memory.

SEE → ■ *Cache Memory (page4-13)*

PCI Configuration

Point the cursor to the [PCI Configuration] and press the [Enter] Key, so that you can go to the set-up screen for PCI IRQ.

SEE → ■ *PCI Configuration (page4-14)*

DMI Event Logging

Point the cursor to [DMI Event Logging] and press the [Enter] Key to go to the set-up screen for DMI event logging.

SEE → ■ *DMI Event Logging (page4-16)*

Disable ACPI_Sx

Specifies the API's state. Select from [None] or [S1]. With this action, the selecting state will be enabled. The factory default setting is [None].

Legacy USB Support

When the USB keyboard is used under DOS, specifies an enabled/disabled state for the USB. The choice is [Enabled] or [Disabled]. The factory default setting is [Enabled].

Enable Memory gap

Specifies an enabled/disabled state for the Memory gap. The choice is [Enabled] or [Disabled]. The factory default setting is [Disabled].

Summary screen

Specifies whether you need to display the Summary screen in running the daisy-chained devices. The choice is [Enabled] or [Disabled]. The factory default setting is [Disable].

QuickBoot Mode

Specifies whether the system boot-up should be “QuickBoot mode”. When the choice is [Disabled], it will execute a system test at the system starting-up. The factory default setting is [Enabled].

Extended Memory Testing

Specifies whether a test for the Extended Memory needs to be executed at the system starting-up. The test types are listed below. The factory default setting is [Just Zero it].

[Normal] Normal test

[Just Zero it] Simple test

[None] No test

Show CMOS Checksum Error

Specifies whether you need to display the errors in case CMOS Checksum Error occurs. The choice is [Enabled] or [Disabled]. The factory default setting is [Disabled].

Power On Delay

Specify whether to set standby time before the system starts up. Select [Enabled] or [Disabled]. When [Enabled] is selected, the system waits for 4 seconds before start-up. The factory default setting is [Disabled].

NOTE

- When the unit is started up with a USB device such as connecting USB memory, the following may occur depending on the device.
 - It takes about one minute before the OS starts up.
 - The PS-A does not recognize the USB device.

These problems may be solved by setting [Power On Delay] to [Enable].

■ Advanced Chipset Control

Point the cursor to the [Advanced Chipset Control] on the [Advanced] screen and press the [Enter] Key, so that the following screen will be displayed.

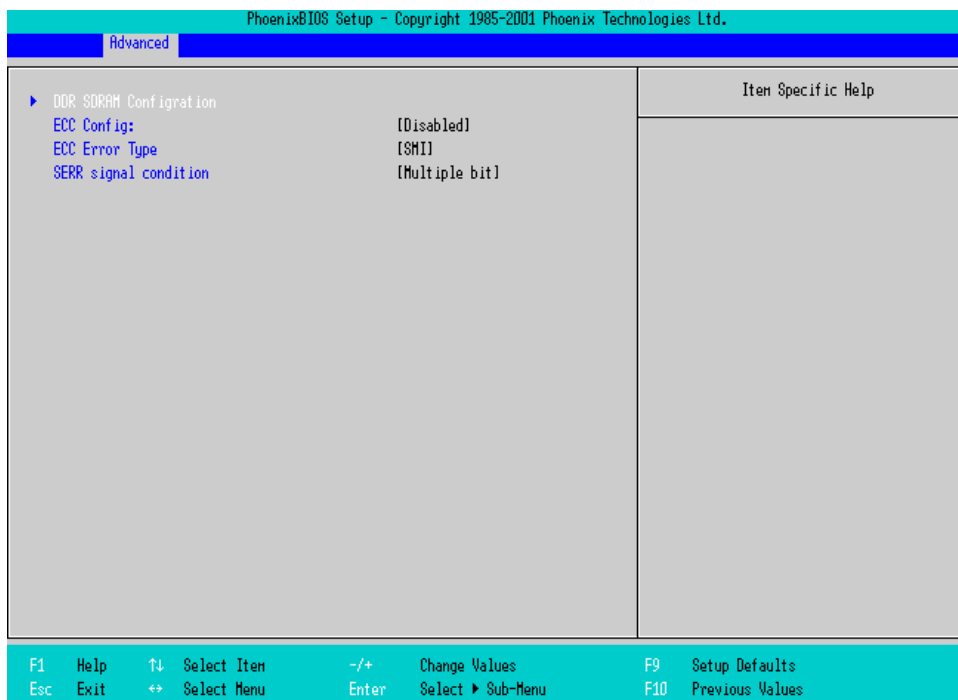

DDR SDRAM Configuration

Point the cursor to the [DDR SDRAM Configuration] and press the [Enter] Key, so that you can go to the Memory Setting screen.

SEE → ◆ *DDR SDRAM Configuration (page 4-10)*

ECC Config

Specifies whether the ECC function for memory, which is a function of recovering errors, needs to be used.

This parameter is displayed only when memory with the ECC function is used. Select from [ECC] or [Disabled]. The factory default setting is [Disabled].

ECC Error Type

Specifies the interruption setting when an ECC error occurs. This parameter is displayed only when memory with the ECC function is used. Select from [None], [NMI], [SMI], or [SCI]. The factory default setting is [SMI].

SERR signal condition

Specifies error bit(s) for ECC. This parameter is displayed only when memory with the ECC function is used. Select from [None], [Single bit], [Multiple bit], or [Both]. The factory default setting is [Both].

◆ DDR SDRAM Configuration

Point the cursor to the [DDR SDRAM Configuration] on the [Advanced Chipset Control] and press the [Enter] Key, so that the following screen will be displayed.

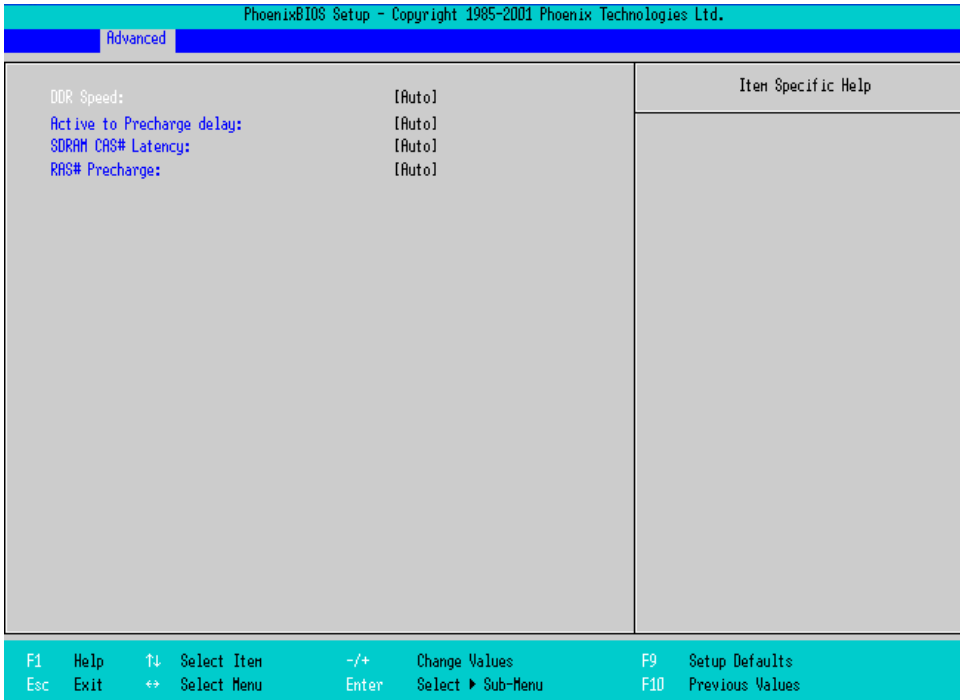

DDR Speed

Specifies the clock frequency for the memory. Select from [Auto], [DDR200], [DDR266], or [DDR333]. The factory default setting is [Auto].

Active to Precharge delay

Controls the timing of DRAM Precharge processing. Select from [Auto], [8Clocks], [7Clocks], [6Clocks], or [5Clocks]. The factory default setting is [Auto].

SDRAM RAS# to CAS# Latency

Specifies the latency time for CAS. Select from [Auto], [2.5], or [2]. The factory default setting is [Auto].

RAS# to CAS Delay

Specifies a transfer timing from RAS to CAS. Select from [Auto], [4DDR SDRAM Clocks (DDR333 SDRAM)], [3DDR SDRAM Clocks], or [2DDR SDRAM Clocks]. The factory default setting is [Auto].

RAS# Precharge

Specifies the number of cycles of RAS precharge. Select from [Auto], [4DDR SDRAM Clocks (DDR333 SDRAM)], [3DDR SDRAM Clocks], or [2DDR SDRAM Clocks]. The factory default setting is [Auto].

■ I/O Device Configuration

Point the cursor to the [I/O Device Configuration] on the [Advanced] screen and press the [Enter] Key, so that the following screen will be displayed.



On board Serial Port 1

Specifies an enabled/disabled state for the COM1. Select from [Disabled] or [Enabled]. The factory default setting is [Enabled]. In addition, the factory default setting for Base I/O Address is [3F8], and for Interrupt is [IRQ 4].

On board Serial Port 2

Specifies an enabled/disabled state for the COM2. Select from [Disabled] or [Enabled]. The factory default setting is [Enabled]. In addition, the factory default setting for Base I/O Address is [2F8], and for Interrupt is [IRQ 3]. The COM2 is used in the system.

■ Keyboard Features

Point the cursor to the [Keyboard Features] on the [Advanced Chipset Control] and press the [Enter] Key, so that the following screen will be displayed.

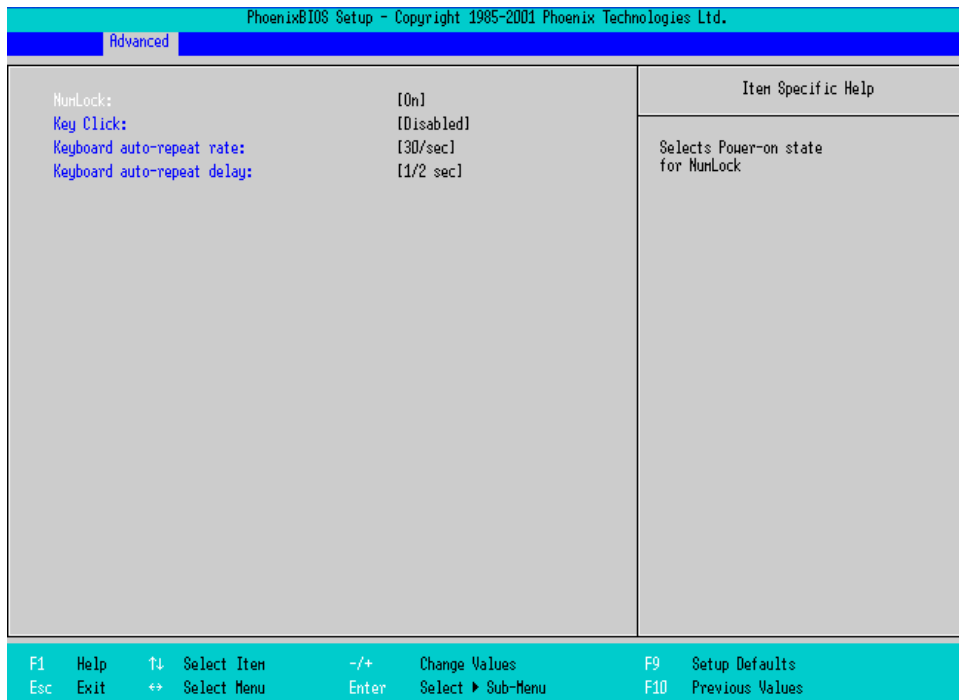

NumLock

Specifies the NumLock status. Select from [Auto], [On], or [Off]. The factory default setting is [On].

KeyClick

Specifies an enabled/disabled state for the keyboard's click sound. Select [Enabled] or [Disabled]. The factory default setting is [Disabled].

Keyboard auto-repeat rate

Specifies the figures of how many times a key can input letters while being pressed for a second. Select from [30/sec.], [26.7/sec.], [21.8/sec.], [18.5/sec.], [13.3/sec.], [10/sec.], [6/sec.], or [2/sec.]. The factory default setting is [30/sec.].

Keyboard auto-repeat delay

Specifies a time duration until the auto-repeat function becomes enabled from a key is pressed. Select from [1/4 sec.], [1/2 sec.], [3/4 sec.], or [1 sec.]. The factory default setting is [1/2 sec.].

■ Cache Memory

Point the cursor to the [Cache Memory] on the [Advanced] screen and press the [Enter] Key, so that the following screen will be displayed.

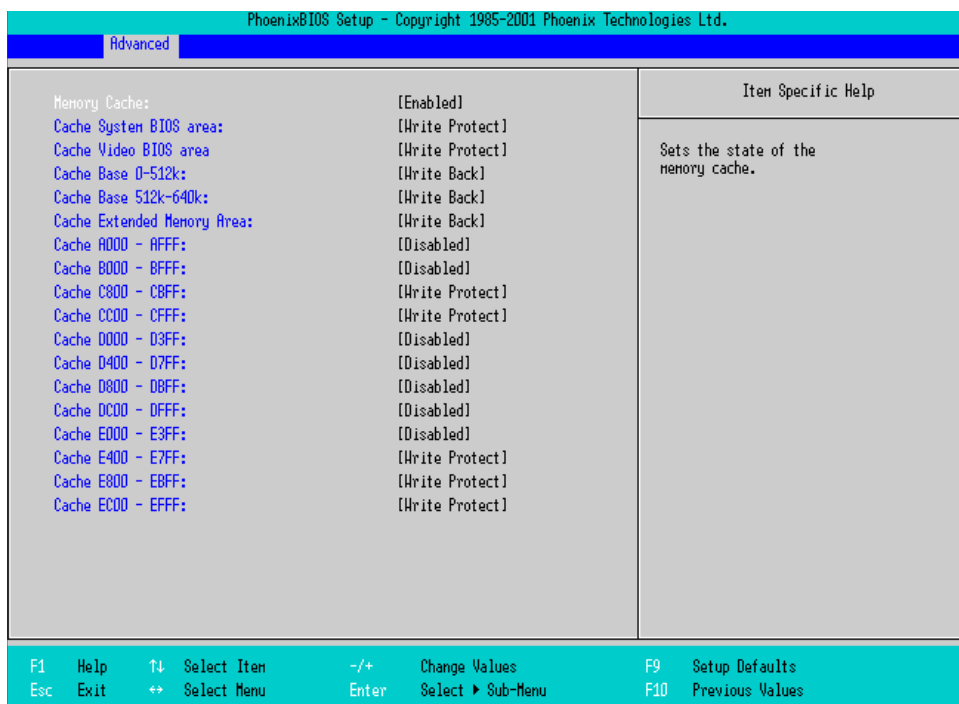

Memory Cache

Specifies an enabled/disabled state for the Memory Cache. The choice is [Enabled] or [Disabled]. The factory default setting is [Enabled].

Cache System BIOS area

Specifies the cache set-up for the System BIOS area. The choice is [uncached] or [Write Protect]. The factory default setting is [Write Protect].

Cache Video BIOS area

Specifies the cache set-up for the VIDEO BIOS area. The choice is [uncached] or [Write Protect]. The factory default setting is [Write Protect].

Cache Base 0-512k

Specifies the cache set-up for the Base Memory, 0 ~ 512k. Select from [uncached], [Write Through], [Write Protect], or [Write Back]. The factory default setting is [Write Back].

Cache Base 512-640k

Specifies the cache set-up for the Base Memory, 512 ~ 620k. Select from [uncached], [Write Through], [Write Protect], or [Write Back]. The factory default setting is [Write Back].

Cache Extended Memory Area

Specifies the cache set-up for the Extended Memory area. Select from [uncached], [Write Through], [Write Protect], or [Write Back]. The factory default setting is [Write Back].

Cache xxxx-xxxx

Specifies the cache setting for each address. Select from [Disabled], [USWC Caching] (The address A000 - AFFF and B000 - BFFF are only available.), [Write Through], [Write Protect], or [Write Back]. The factory default setting is as follows.

A000 - AFFF	Disabled
B000 - BFFF	Disabled
C800 - CBFF	Write Protect (VIDEO Memory)
CC00 - CFFF	Write Protect
D000 - D3FF	Disabled
D400 - D7FF	Disabled
D800 - DBFF	Disabled
DC00 - DFFF	Disabled
E000 - E3FF	Disabled
E400 - E7FF	Write Protect (PXE)
E800 - EBFF	Write Protect
EC00 - EFFF	Write Protect

■ PCI Configuration

Point the cursor to the [PCI Configuration] on the [Advanced] screen and press the [Enter] Key, so that the following screen will be displayed.

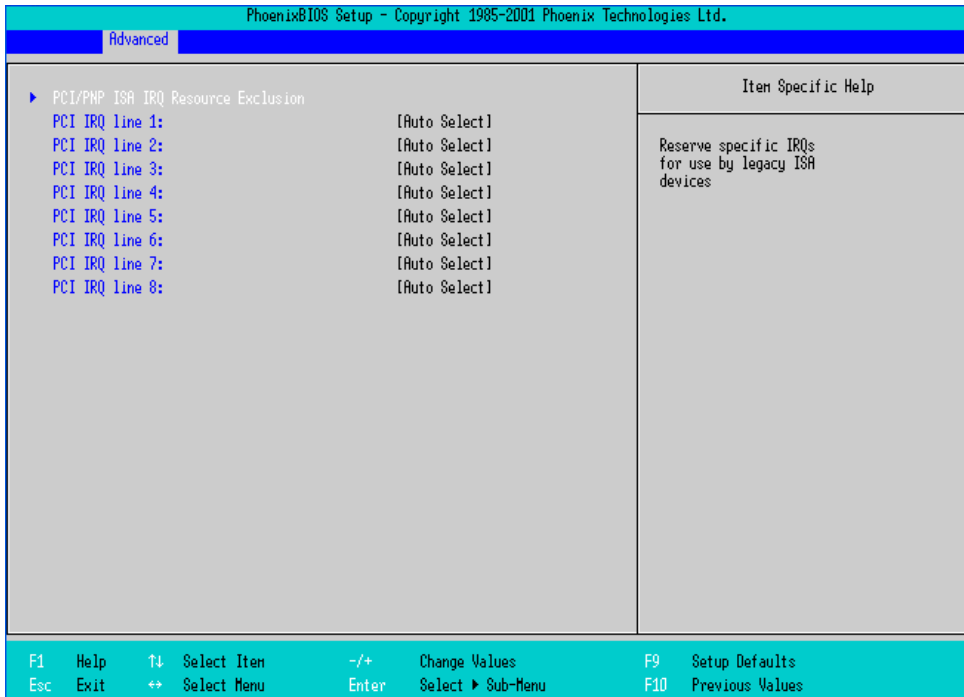

PCI/PNP ISA IRQ Resource Exclusion

Move the cursor to the [PCI/PNP ISA IRQ Resource Exclusion] on the [PCI Configuration] screen and press the [Enter] Key, so that you can go to the ISA IRQ set-up screen.

SEE → ◆ *PCI/PNP ISA IRQ Resource Exclusion (page4-15)*

PCI IRQ line 1 to 8

Specifies the Interrupt Request Lines (IRQ) for PCI. Select from [Disabled], [Auto Select], [3], [4], [5], [7], [9], [10], [11], [12], [14], or [15]. The factory default setting is [Auto Select].

◆ PCI/PNP ISA IRQ Resource Exclusion

Point the cursor to the [PCI/PNP ISA IRQ Resource Exclusion] on the [PCI Configuration] screen and press the [Enter] Key, so that the following screen will be displayed.

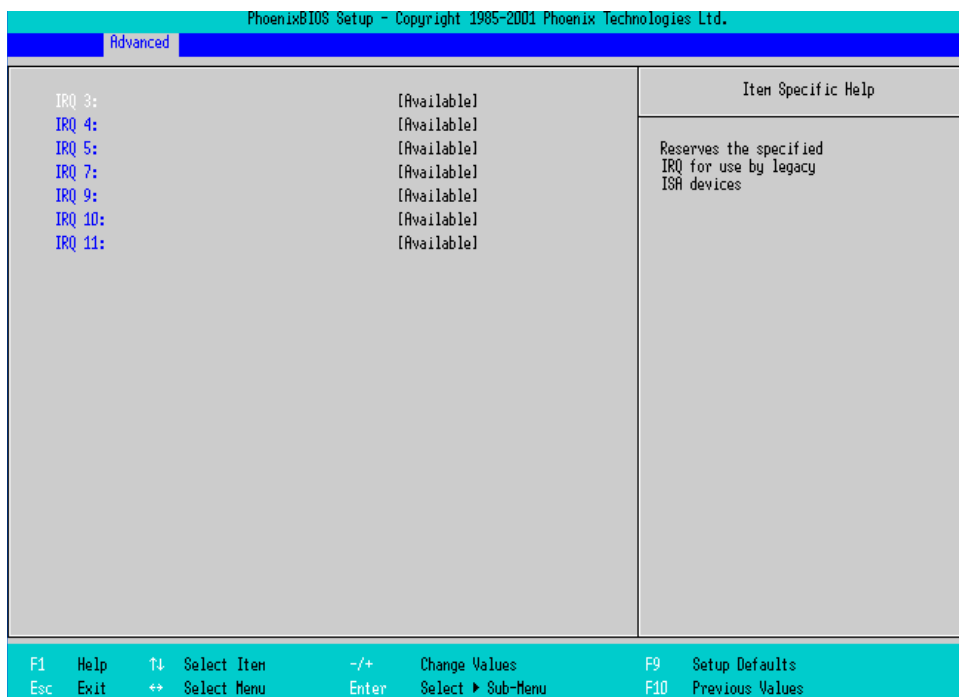

IRQ 3, 4, 5, 7, 10, 11

Specifies the IRQ which is allocated to the legacy device. Select from [Available] or [Reserved]. The factory default setting is [Available].

■ DMI Event Logging

Specifies the parameters related to DMI event logging. Point the cursor to the [DMI Event Logging] on the [Advanced] screen and press the [Enter] Key, so that the following screen will be displayed.

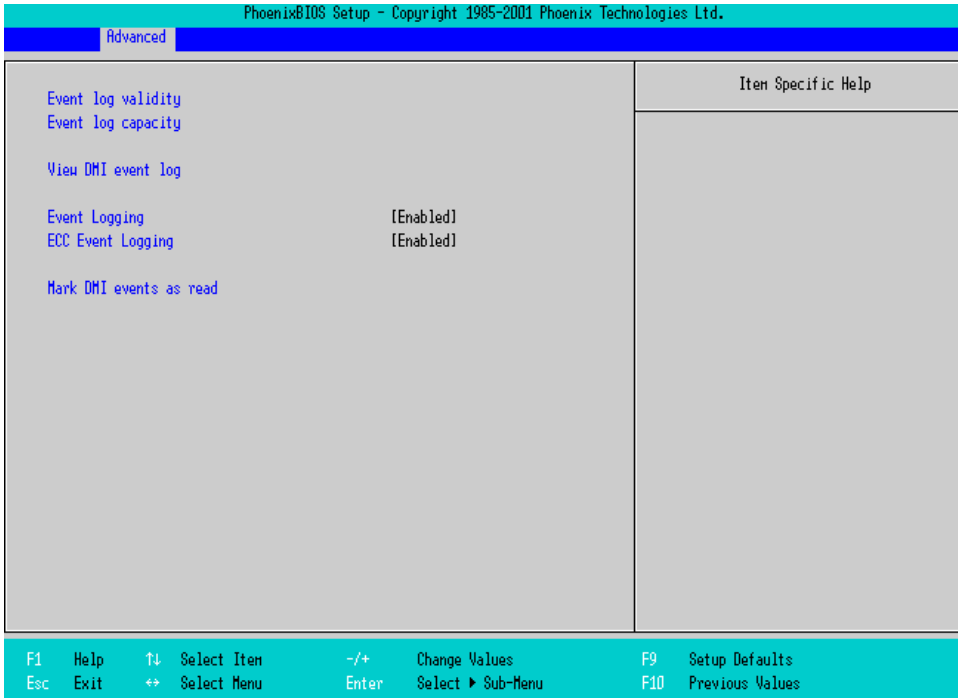

Event log validity

Shows the status of the event log storage area. [Valid] is shown when the status is normal, and [Not valid] is shown when the status is abnormal.

Event log capacity

Shows the status of the area to which event logs are written. [Full] is shown when the area is full, and [Space Available] is shown when the area is not full.

View DMI event log

Point the cursor to [View DMI event log] and press the [Enter] Key to view the DMI event logs.

Event Logging

Specifies whether event logs need to be recorded. Select from [Enabled] or [Disabled]. The factory default setting is [Enabled].

ECC Event Logging

Specifies whether the event logs related to memory ECC need to be recorded. Select from [Enabled] or [Disabled]. The factory default setting is [Enabled].

Mark DMI events as read

Point the cursor to [Mark DMI events as read] and press the [Enter] Key to mark unread event logs as read.

4.2.3 Intel

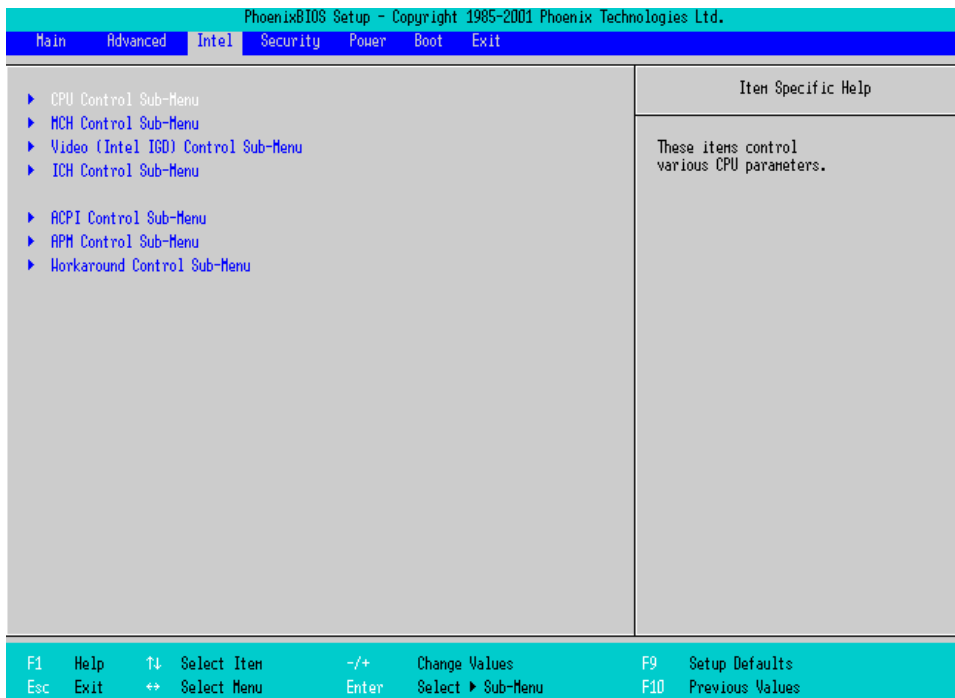

CPU Control Sub-Menu

Point the cursor to the [CPU Control Sub-Menu] on the [Intel] screen and press the [Enter] key, so that you can go to the [CPU] set-up screen.

SEE → ■ *CPU Control Sub-Menu (page4-18)*

MCH Control Sub-Menu

Point the cursor to the [MCH Control Sub-Menu] on the [Intel] screen and press the [Enter] key, so that you can go to the [MCH] set-up screen.

SEE → ■ *MCH Control Sub-Menu (page4-19)*

Video (Intel IGD) Control Sub-Menu

Point the cursor to the [Video (Intel IGD) Control Sub-Menu] on the [Intel] screen and press the [Enter] key, so that you can go to the set-up screen for display.

SEE → ■ *Video (Intel IGD) Control Sub-Menu (page4-21)*

ICH Sub-Menu

Point the cursor to the [ICH Control Sub-Menu] on the [Intel] screen and press the [Enter] key, so that you can go to the [ICH] set-up screen.

SEE → ■ *ICH Control Sub-Menu (page4-22)*

ACPI Control Sub-Menu

Point the cursor to the [ACPI Control Sub-Menu] on the [Intel] screen and press the [Enter] key, so that you can go to the [ACPI] set-up screen.

SEE → ■ *ACPI Control Sub-Menu (page4-24)*

APM Control Sub-Menu

Point the cursor to the [APM Control Sub-Menu] on the [Intel] screen and press the [Enter] key, so that you can go to the [APM] set-up screen. If you use APM OS, you are requested to set up this configuration.

SEE → ■ *APM Control Sub-Menu (page4-25)*

Workaround Control Sub-Menu

Point the cursor to the [Workaround Control Sub-Menu] on the [Intel] screen and press the [Enter] key, so that you can go to the set-up screen of the whole platform.

SEE → ■ *Workaround Control Sub-Menu (page4-26)*

■ CPU Control Sub-Menu

Point the cursor to the [CPU Control Sub-Menu] on the [Intel] screen and press the [Enter] key, so that the following screen will be displayed.

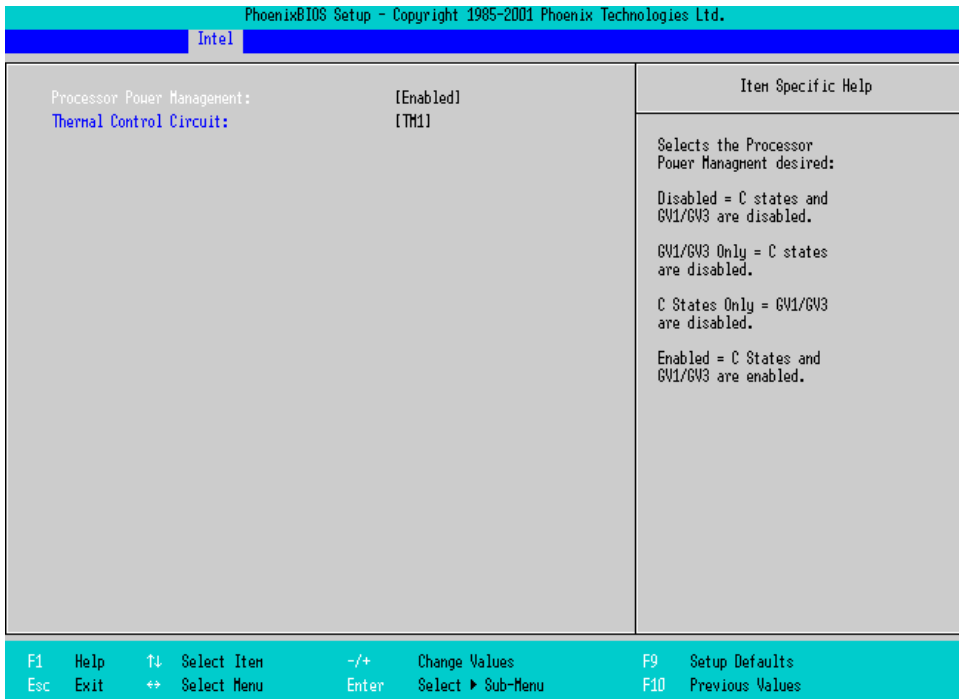

Processor Power Management

This is a function that controls the processor’s power state. Select from [Disabled] or [C States Only]. The factory default setting is [C States Only] and the default should be applied.

Thermal Control Circuit

This is a function that protects the CPU's temperature, and its setting is a situation that if it exceeds the limit that CPU is able to work properly. Select from [Disabled], [TM1], or [TM2]. The factory default setting is [TM2] and the default should be applied.

■ MCH Control Sub-Menu

Point the cursor to the [MCH Control Sub-Menu] on the [Intel] screen and press the [Enter] key, so that the following screen will be displayed.

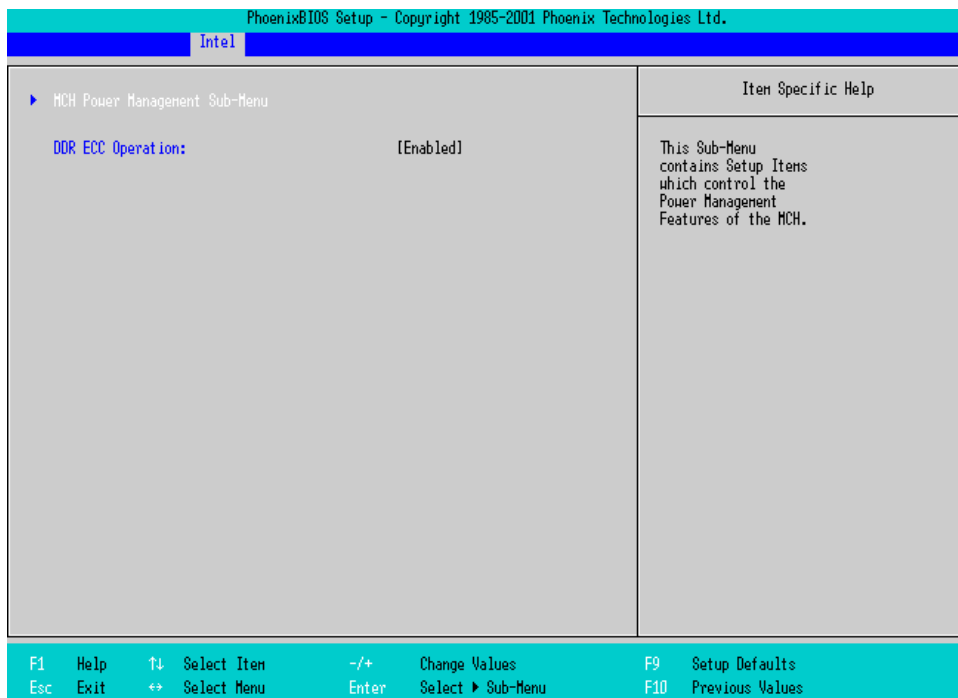

MCH Power Management Sub-Menu

Goes to the Chipset set-up screen.

SEE → ◆ *MCH Power Management Sub-Menu (page4-20)*

DDR ECC Operation

Specifies whether you use ECC memory or not. The choice is [Enabled] or [Disabled] and the default factory setting is [Enabled].

◆ MCH Power Management Sub-Menu

Point the cursor to the [MCH Power Management Sub-Menu] on the [Intel] screen and press the [Enter] key, so that the following screen will be displayed.

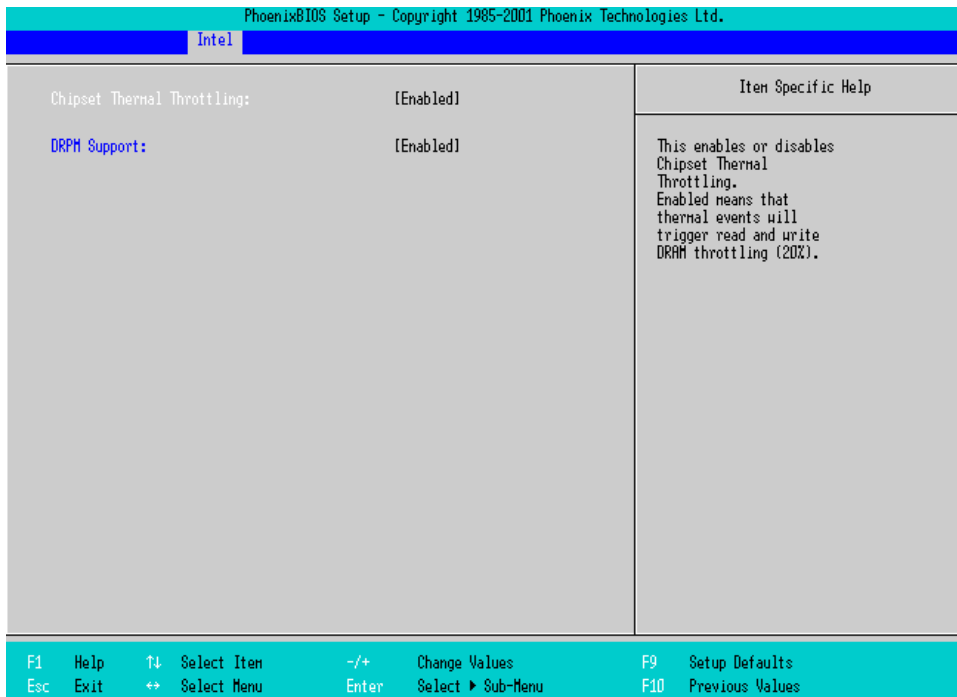

Chipset Thermal Throttling

Specifies a thermal throttle, a system to prevent a themorunway, for chipset. The choice is [Enabled] or [Disabled]. The factory default setting is [Enabled].

DRPM Support

Specifies an enabled/disabled state for the setting of Dynamic Row Power Management. The choice is [Enabled] or [Disabled]. The factory default setting is [Enabled].

■ Video (Intel IGD) Control Sub-Menu

Point the cursor to the [Video (Intel IGD) Control Sub-Menu] on the [Intel] screen and press the [Enter] key, so that the following screen will be displayed.

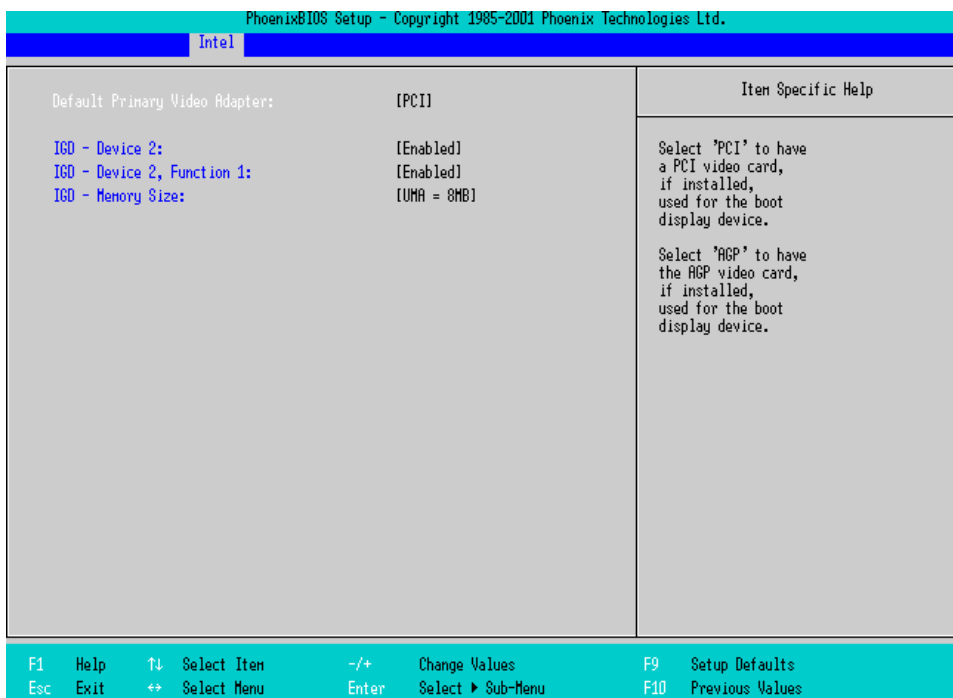

IGD-Memory Size

Specifies an allocation capacity for the Video Memory. Select from [UMA=1MB], [UMA=8MB], [UMA=16MB], or [UMA=32MB]. The factory default setting is [UMA=8MB].

■ ICH Control Sub-Menu

Point the cursor to the [ICH Control Sub-Menu] on the [Intel] screen and press the [Enter] key, so that the following screen will be displayed.

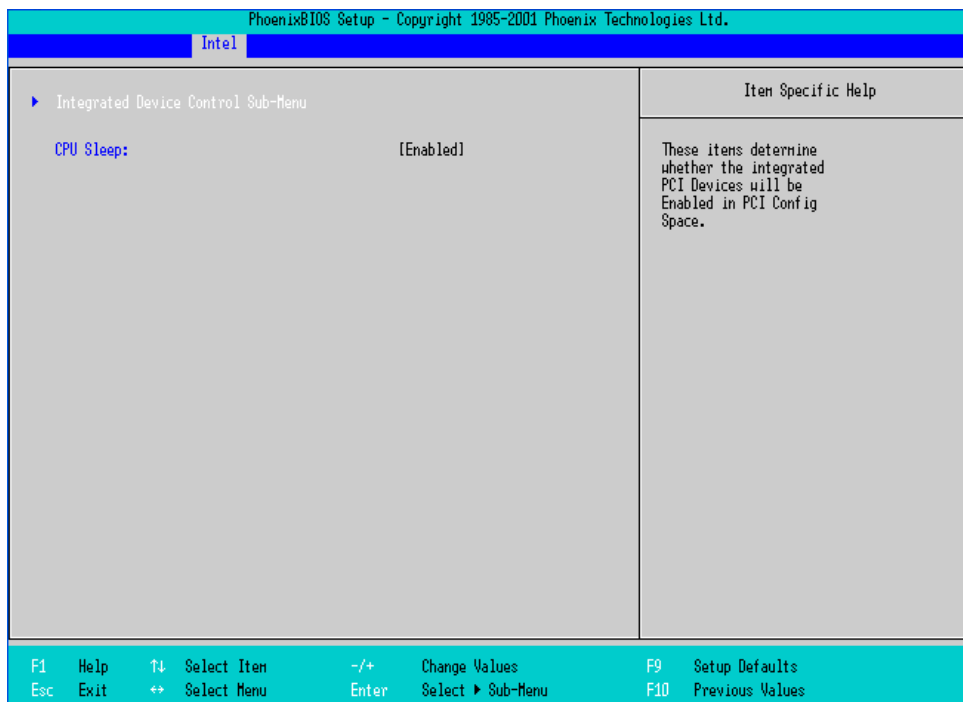

Integrated Device Control Sub-Menu

Goes to the setting screen where an enabled/disabled state for the USB, LAN and PCMCIA is specified.

SEE → ◆ *Integrated Device Control Sub-Menu (page4-23)*

CPU Sleep

Specifies whether the CPU needs power saving. The choice is [Enabled] or [Disabled]. The factory default setting is [Enabled].

◆ Integrated Device Control Sub-Menu

Point the cursor to the [Integrated Device Control Sub-Menu] from the [ICH Control Sub-Menu] on the [Intel] screen and press the [Enter] Key, so that the following screen will be displayed.

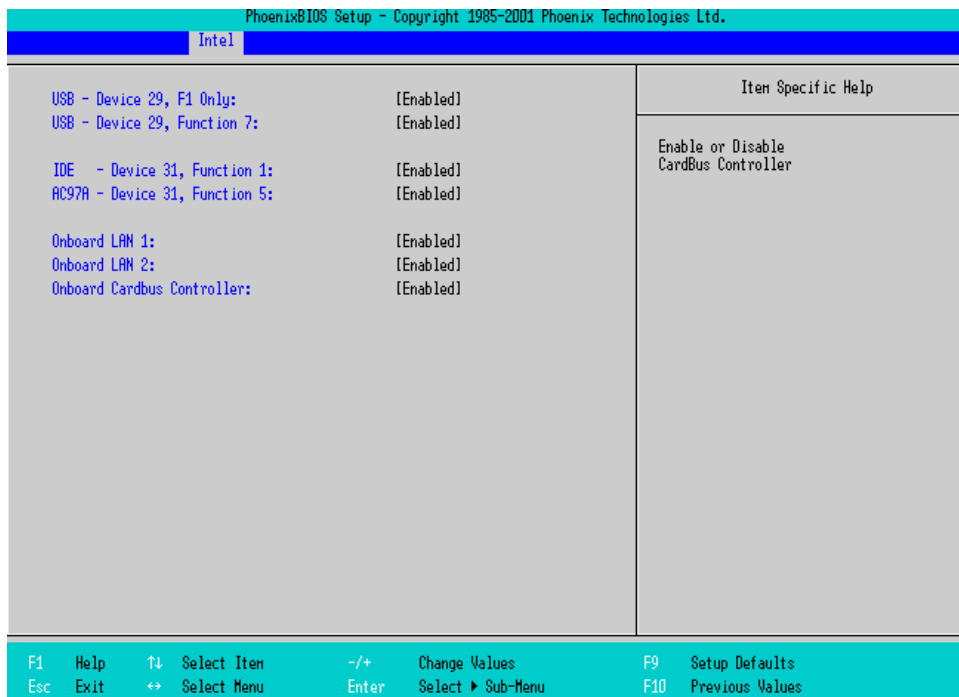

USB-Device 29, F1 only / USB-Device 29, Function 7

Specifies an enabled/disabled state for the USB device. The choice is [Enabled] or [Disabled]. The factory default setting is [Enabled].

IDE-Device 31, Function 1

Specifies an enabled/disabled state for the IDE device. The choice is [Enabled] or [Disabled]. The factory default setting is [Enabled].

AC97A-Device 31, Function 5

Specifies an enabled/disabled state for the AC97 Audio. The choice is [Enabled] or [Disabled]. The factory default setting is [Enabled].

Onboard LAN 1, 2

Specifies an enabled/disabled state for the Onboard LAN 1,2. The choice is [Enabled] or [Disabled]. The factory default setting is [Enabled].

Onboard Cardbus Controller

Specifies an enabled/disabled state for the PCMCIA slot. The choice is [Enabled] or [Disabled]. The factory default setting is [Enabled].

■ ACPI Control Sub-Menu

Point the cursor to the [ACPI Control Sub-Menu] on the [Intel] screen and press the [Enter] key, so that the following screen will be displayed.

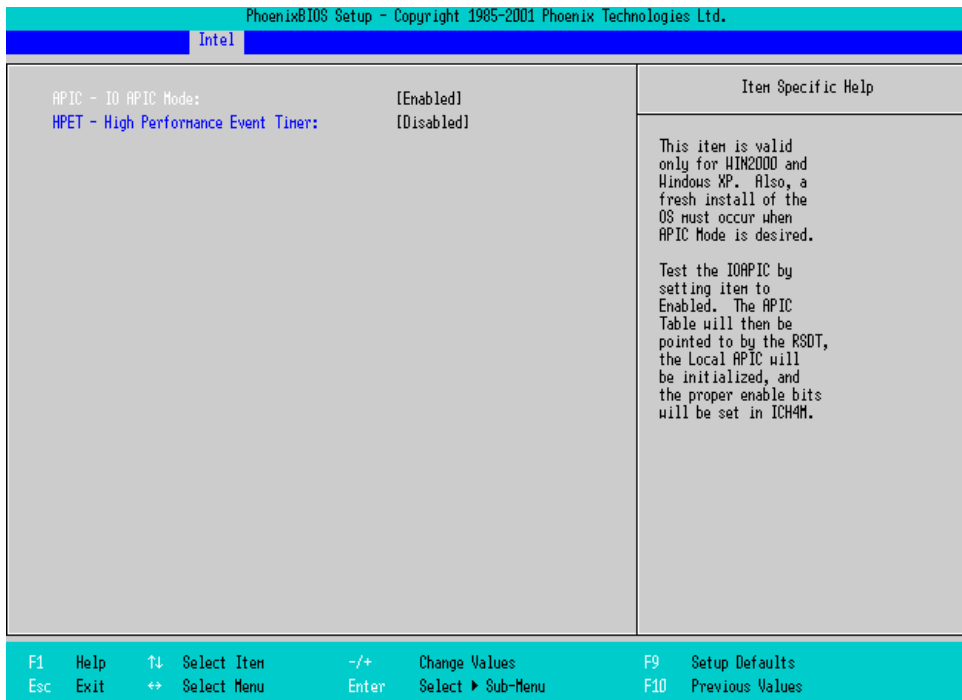

ACPI-IO APIC Mode

Specifies an enabled/disabled state for the APIC. The choice is [Enabled] or [Disabled]. The factory default setting is [Enabled].

HPET-High Performance Event Timer

Specifies the timer setting for the High Precision Event Timer. The choice is [Enabled] or [Disabled]. The factory default setting is [Disabled].

■ APM Control Sub-Menu

Point the cursor to the [APM Control Sub-Menu] on the [Intel] screen and press the [Enter] key, so that the following screen will be displayed.

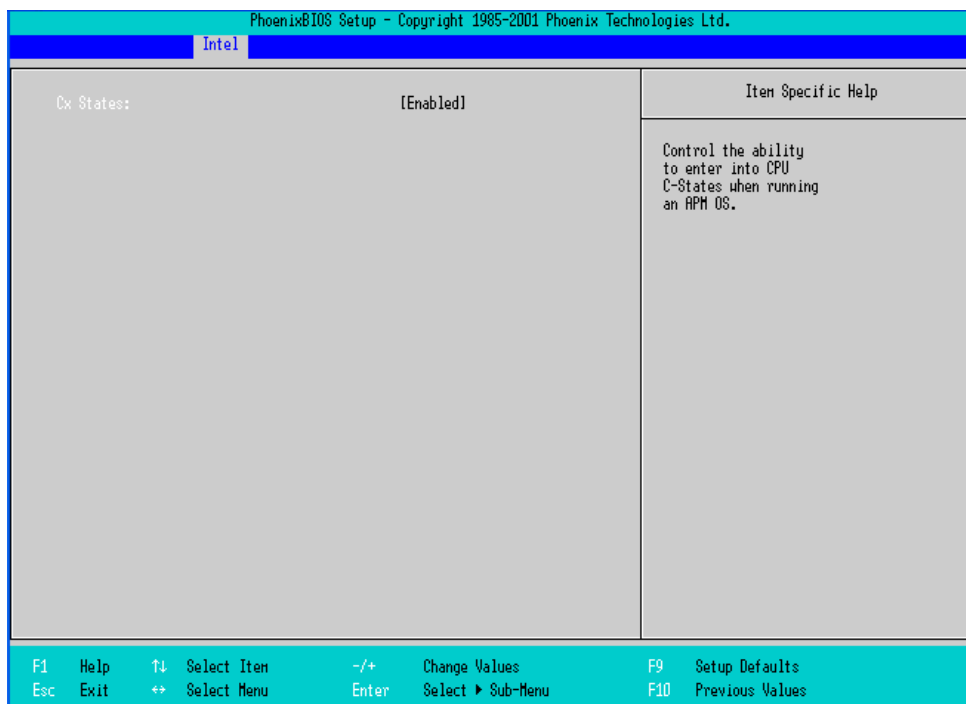

CX Status

Specifies whether you use a power saving state when using APM OS. The choice is [Enabled] or [Disabled].

The factory default setting is [Enabled].

■ Workaround Control Sub-Menu

Point the cursor to the [Workaround Control Sub-Menu] on the [Intel] screen and press the [Enter] key, so that the following screen will be displayed.

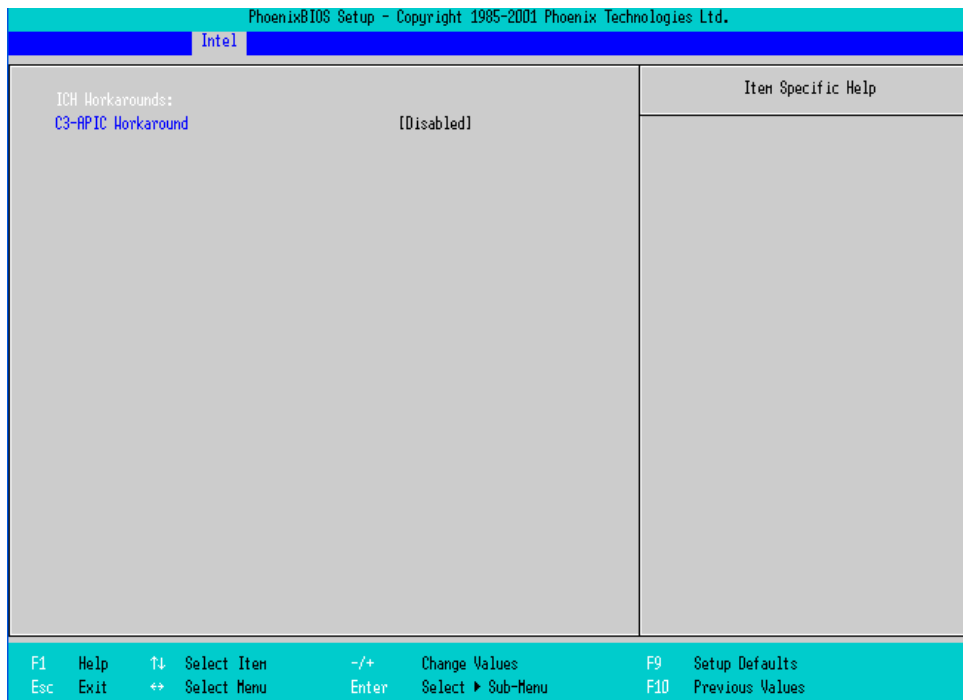

C3-APIC Workaround

Select from [Enabled], [Auto], or [Disabled]. The factory default setting is [Enabled].

4.2.4 Security

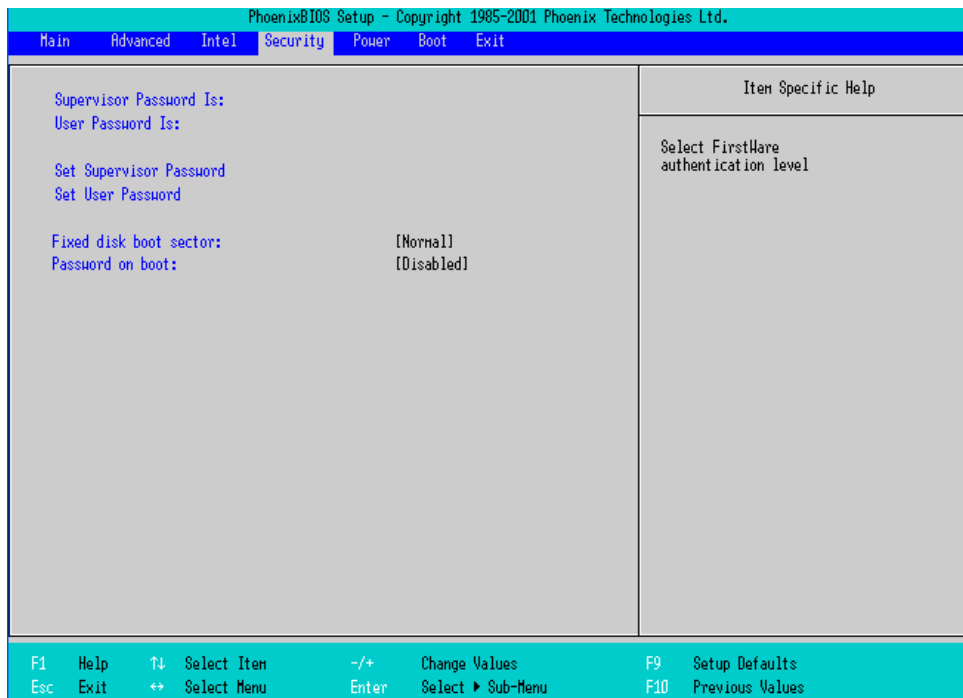
**Supervisor Password Is**

Displayed as “Set” when the password is set. Since no password has been set at factories, the factory default setting is [Clear].

User Password Is

Displayed as “Set” when the password is set. Since no password has been set at factory, the factory default setting is [Clear]. Note that BIOS setting is not allowed with a User Password.

Set Supervisor Password / Set User Password

Specifies a password. When any password is not needed, do not input any values in the new password setting and press just the [Enter] key.

Fixed disk boot sector

Specifies whether writing into the boot sector on the hard disk is not allowed. Select from [Normal], [Write Protect], or [Protect]. The factory default setting is [Normal].

Password on boot

Specifies whether a password should be needed at the Start-Up. The choice is [Enabled] or [Disabled]. The factory default setting the is [Disabled].

4.2.5 Boot

Specifies an order for boot-up devices. The boot-up devices are specified in the Boot priority order list and are searched for from the top of the list in sequence. By using the [+] or [-] keys, change its order. To change the device to be booted up, use the [x] key to move the device from the Boot priority order list to the Excluded from boot order list and vice versa.

- When a new hard disk or commercial USB memory which does not require boot-up is connected and such a device is given high priority in the Boot priority order list, the system may not boot up properly. Be sure to check the order of the devices in the Boot priority order list after you connect a new device.

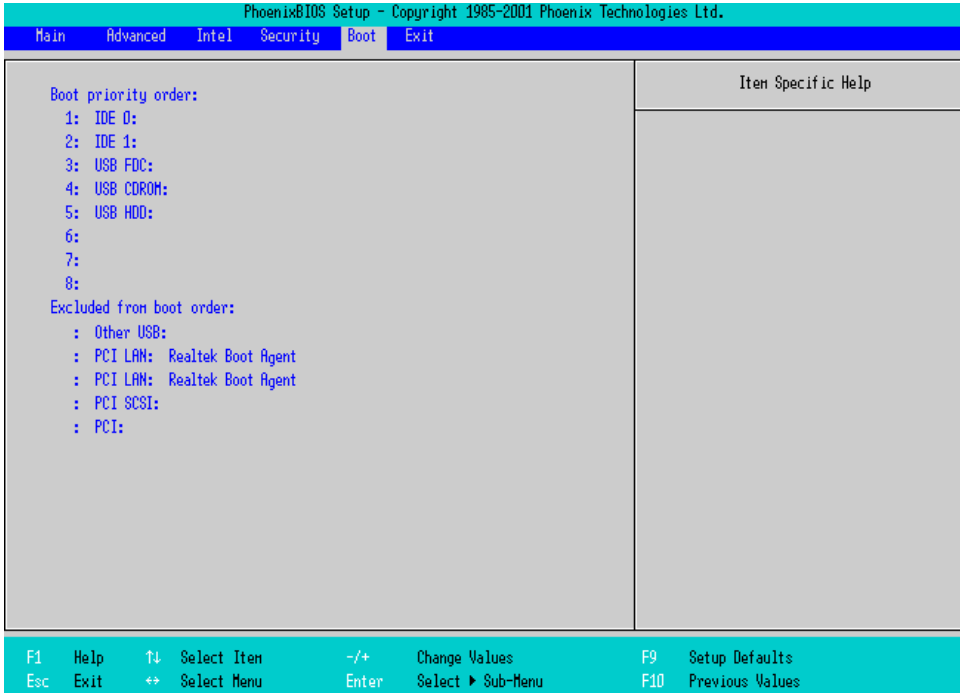

Boot priority order

Specifies the order of the boot-up devices. The factory default settings are as follows:

- 1: IDE 0 : Primary Master Device
- 2: IDE 1 : Primary Slave Device
- 3: USB FDC : USB Floppy Disk Driver
- 4: USB CDROM : USB CDROM Driver
- 5: USB HDD : USB Memory, etc.
- 6:
- 7:
- 8:

Excluded from boot order

- : IDE 2 : Secondary Master Drive
- : Other USB : Other USB media
- : PCI LAN : LAN 1 PXE Boot ROM
- : PCI LAN : LAN 2 PXE Boot ROM
- : PCI SCSI : PCI SCSI Board

4.2.6 Exit



Exit Saving Changes

Point the cursor to the [Exit Saving Changes] on the [Exit] screen and press the [Enter] key, the current configuration is saved and the setting procedure is ended.

Exit Discarding Changes

Point the cursor to the [Exit Discarding Changes] on the [Exit] screen and press the [Enter] key, the current configuration is NOT saved but the setting procedure is ended.

Load Setup Defaults

Point the cursor to the [Load Setup Defaults] on the [Exit] screen and press the [Enter] key, all of the current configuration is back to the factory default settings.

Discard Changes

Point the cursor to the [Discard Changes] on the [Exit] screen and press the [Enter] key, the current modified configuration is canceled and the previous setting values are reloaded.

Save Changes

Point the cursor to the [Save Changes] on the [Exit] screen and press the [Enter] key, the current configuration which you modified is saved.

5



Setting up Software

1. Software Configuration
2. Setting Up Your PS-A Unit
3. PS-A Dedicated Software
4. Cautions When Using Windows® 2000/Windows® XP

5.1 Software Configuration

If you purchased the PS-A unit with pre-installed OS, all the software has been installed already.

If you purchased the PS-A unit with no pre-installed OS, you can download the software from the Pro-face support site “Otasuke Pro!”.

SEE → 5.3 PS-A Dedicated Software (page5-6)

5.2 Setting Up Your PS-A Unit

There are two types of PS-A units. One has a hard disk with no pre-installed OS and the other has a hard disk with a pre-installed OS. Therefore, the setup procedures used will differ.

5.2.1 Setting Up an HDD with no Pre-installed OS

First, when you use a hard disk with no pre-installed OS, you will need to install either Windows® 2000 or Windows® XP. You also need to install any required utility software.

■ Setting Up the OS

Install your operating system. For the setup procedures about the OS, refer to that product’s installation manual.

- IMPORTANT**
- Specify [Disabled] for the USB-Device29 and the Function7 of the BIOS when you install commercial Windows® 2000, using a USB CD-ROM drive.

SEE → ◆ *Integrated Device Control Sub-Menu (page4-23)*

- The PS-A unit supports Windows® 2000 Service Pack 4 and Windows® XP Service Pack 2. The PS-A unit performance cannot be guaranteed when any other operating system is used.

■ Special PS-A Software Setup

Download the necessary drivers and utility software from the Pro-face support site “Otasuke Pro!”.

URL <http://www.pro-face.com/otasuke/>

- NOTE**
- The setup requires a USB keyboard.
 - For details about the drivers and utility software, refer to the following section.

SEE → 5.3 PS-A Dedicated Software (page5-6)

■ [Proface] Folder Configuration

The following diagram describes the configuration of this folder. (For all Windows[®] versions)

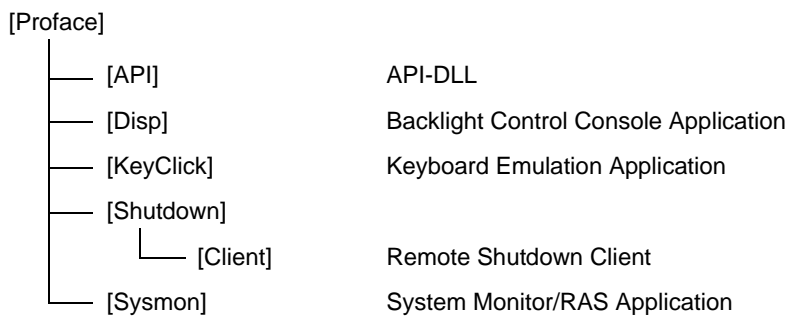

5.2.2 Setting Up an HDD with Pre-installed OS

In the PS-A with pre-installed OS, the following software has been installed in advance.

NOTE

- Each pre-installed operating system on the hard disk in the PS-A unit is designed specially for PS-3650A/PS-3651A.

■ PS-A with Windows® 2000 Pre-installed

- Windows® 2000 Professional operating system manufactured by Microsoft Corporation
- Mouse Emulation Software manufactured by DMC Co., Ltd. (TSC-1310D/DD)
- Keyclick32 keyboard emulator manufactured by IN-fINITY soft
- PS-A dedicated utility software and drivers manufactured by Pro-face

■ PS-A with Windows® XP Pre-installed

- Windows® XP Professional operating system manufactured by Microsoft Corporation
- Mouse Emulation Software manufactured by DMC Co., Ltd. (TSC-1310D/DD)
- Keyclick32 keyboard emulator manufactured by IN-fINITY soft
- PS-A dedicated utility software and drivers manufactured by Pro-face

NOTE

- Each pre-installed operating system on the hard disk in the PS-A unit is designed specially for PS-3650A/PS-3651A.
- For details about the drivers and utility software, refer to the following section.



5.3 PS-A Dedicated Software (page5-6)

■ Setting Up OS

Set up the Pre-installed OS in the PS-A unit. For the setup procedures about the OS, refer to the Installation Guide that comes with the HDD unit with the pre-installed OS.

NOTE

- When setup is completed, a README file is created on the desktop. The README file contains details regarding software and information released since the creation of this manual. Read the README file first after setup is completed.

■ [Proface] Folder Configuration

The following diagram describes the configuration of this folder.

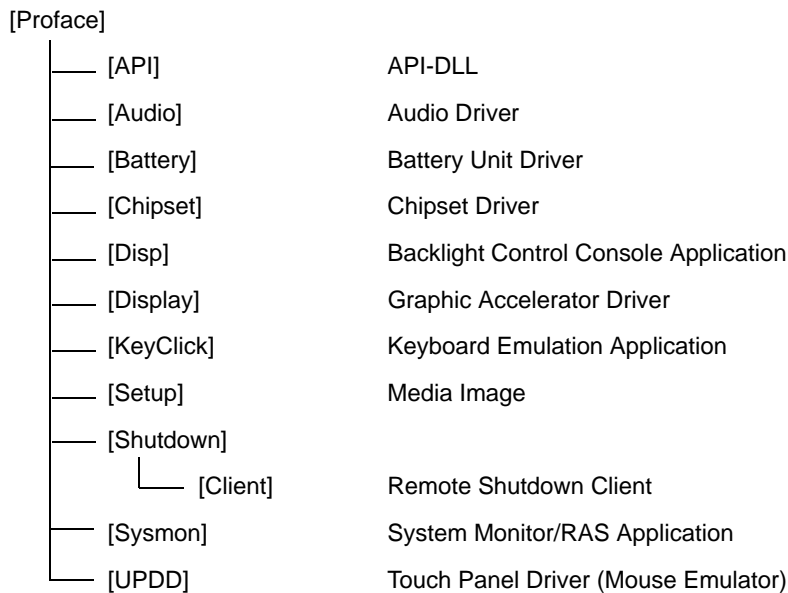

5.3 PS-A Dedicated Software

5.3.1 Driver

Four types of dedicated PS-A drivers (Audio, Chipset, Graphic Accelerator and Touch Panel Driver (Mouse Emulator) are available.

Install the required drivers when using a PS-A with no pre-installed OS (A PS-A unit that has been recovered using the Recovery media will have all the required drivers installed). This explanation given in this section assume that the [Proface] folder has been created.

IMPORTANT

- Do not uninstall the drivers which have been installed in the PS-A unit.

■ Chipset Driver

Installing the Chipset driver adds the Chipset feature to the OS.

Start “C:\Proface\Chipset\ininst_autol.exe” file.

Follow the instructions given on the screen to install the driver.

■ Audio Driver

Installing the Audio driver enables the OS’ Audio feature.

Start “C:\Proface\Audio\WDM_A□□□.exe” file. (“□□□” indicate the driver version.)

Follow the instructions given on the screen to install the driver.

■ Graphic Accelerator Driver

Installing the Graphic Accelerator Driver will accelerate the screen refresh speed, using special hardware features.

Start “C:\Proface\Display\win2K_xp□□□.exe” file. (“□□□” indicate the driver version.)

Follow the instructions given on the screen to install the driver.

■ Mouse Emulator

Install the Touch Panel Driver in the PS-A unit. It's necessary to agree to D.M.C.'s Mouse Emulation Software (TSC-1310D/DD) License in advance.

SEE → *Appendices 4 License Agreement (page A-5)*

- (1) Start "C:\Proface\UPDD\Setup.exe" file.
- (2) Follow the instructions given on the screen to install the Touch Panel Driver.

For the detailed settings, refer to C:\Proface\UPDD_30846\Readme.pdf

NOTE

- You can open "Touch Panel Property" by selecting the [Start] -> [Programs] -> [UPDD] -> [Settings]. In this dialog box, you can specify the details of the touch panel operation.
- If the touch position recognized in the panel deviates from the actual touch, you need to calibrate the touch panel. Select the [Start] -> [Programs] -> [UPDD] -> [Calibration]. When a cross appears on the screen, press it. Then click [OK] in the [Confirmation after calibration] dialog box to finish the calibration.

5.3.2 Special Application Program Features

The special programs designed for the PS-A unit are located in the following folders. Here, it is assumed that the [Proface] folder has already existed on the hard disk of the PS-A unit.

File Name	Windows® XP	Windows® 2000
Smonras.dll	C:\Windows\System32	C:\Winnt\System32
loctl.dll		
Bliocctl.dll		
Backlight Control.scr		
BIBright.cpl		
Disp.exe	C:\Proface\Disp	
Keyclick.exe	C:\Proface\Keyclick	
SystemMonitor.exe	C:\Proface\Sysmon	
SmSRvCPL.cpl	C:\Windows\System32	C:\Winnt\System32
Sysmon.sys	C:\Windows\System32\Drivers	C:\Winnt\System32\Drivers

NOTE • To uninstall the installed utility software, select [Add or Remove Programs] from Control Panel, and then select [PS-3650A Series Driver and Utility] to remove it.

■ API-DLL

These dynamic link libraries allow users to access RAS features that operates on the PS-A via custom-made applications. The following three types are available.

◆ Shared Memory Access: Smonras.dll

This dynamic link library allows users to access shared memory via remote RAS features.

For details, refer to the API Reference Manual.

◆ RAS Features: loctl.dll

This dynamic link library allows users to access RAS features that operates on the PS-A via custom-made PS-A applications.

For details, refer to the API Reference Manual.

◆ Backlight Control: Bliocctl.sll

This dynamic library allows User-created applications to utilize the PS-A backlight control feature that operates on the PS-A.

For details, refer to the API Reference Manual.

■ System Monitoring/RAS Application: SystemMonitor.exe

The RAS and System Monitoring features allow users to monitor temperature, voltage, and fan operation alarms. This program is started automatically at the same time as the OS.

◆ System Monitoring Program: SystemMonitor.exe

SEE → ■ *When an Error Occurs (page6-13)*

◆ Watchdog Parameter Setup Program: System Monitor Property

SEE → 6.3.1 *Description (page6-10)*

■ System File: Sysmon.sys

This system file allows use of the RAS and System Monitoring features. This file should not be modified. If it is modified, the RAS and System Monitoring features may not operate correctly.

■ Backlight OFF Screen Saver: Backlight Control.scr

This software is used to turn OFF the PS-A's backlight after a specified period of inactivity. The use of this feature will help to extend the life of the PS-A's backlight. This program runs on Windows®.

NOTE

- Certain application programs may not allow the PS-A's backlight to turn OFF. Test each program individually to check if the screen saver will operate correctly before use.

■ Backlight Control Console Application: Disp.exe

This command line utility is used to turn OFF both the PS-A's backlight and display. This program runs on the command prompt.

Settings Used	DISP [ON/OFF] <input type="checkbox"/>
Option Switch	ON: Displayed / OFF: Not Displayed
Return Value	0: Completed Normally / -1: Option Switch Error

IMPORTANT

- If your application requires that the OS continuously turn the backlight display ON and OFF, be sure to use the backlight control dll, Bliocctl.dll.

■ Keyboard Emulator: Keyclick.exe

This program allows the User's mouse operation to perform keyboard-like data input. When this program is executed on Windows®, a keyboard is displayed on the screen of the PS-A unit.

It is required to agree to "IN-FINITY soft Keyclick32 License Agreement

SEE → *Appendices 4 License Agreement (page A-5)*

NOTE

- Certain application programs may not support this keyboard emulator. Test each application individually to check if the keyboard emulator will operate correctly.
- This program cannot be used to enter Windows® startup screen User Name and Password information.
- To change the Keyclick program's font size a keyboard is required.
- For details concerning the Keyclick program's operation, simply click on the HELP button on the screen keyboard to call up the program's online help data.

■ Backlight Brightness Adjustment: BIBright.cpl

Backlight brightness can be set to one of four levels: Level 0, Level 1, Level 2 or Level 3.

Brightness level 0: Very dark

Brightness level 1: Somewhat dark

Brightness level 2: Somewhat bright

Brightness level 3: Very bright

To use this program, when you use Windows® 2000, click the [Control Panel]'s [Backlight Brightness] icon, and when you use Windows® XP, click the [Backlight Brightness] icon of the [Control Panel]'s [Appearance and Themes]. The default setting is Brightness level 3.

■ System Monitor Property: SmSRvCPL.cpl

This program allows the user to set the notification method used in event of an error while the RAS feature monitors the system. Execute the program from the [System Monitor Property] icon. To use this program, click the [Control Panel]'s [System Monitor Property] icon.

5.4 Cautions When Using Windows® 2000/Windows® XP

Do the following process if necessary.

5.4.1 Automatic System Log-on Setup

This setting allows users to simplify password entry at startup.

■ Windows® 2000

- (1) Double-click on the [Control Panel]'s [User and Password] icon.
- (2) Designate the automatic logon user, and deselect the [User must enter the user name and password to use this computer] checkbox.
- (3) Click on the [Advanced] tab, and deselect the [Require users to press Ctrl + Alt + Del keys before logging on] checkbox.
- (4) Click the [Apply] button. Next, when the automatic logon dialog box appears, enter the password.

■ Windows® XP

- (1) Select [Run] from the [Start] screen.
- (2) Enter "Control userpasswords2", and click [OK].
- (3) Deselect the [User must enter the user name and password to use this computer] checkbox and click [Apply].
- (4) Enter the user name and password for automatic logon and click [OK].

NOTE

- If automatic logon is not used, a USB keyboard is required to logon.

5.4.2 Uninterrupted Power Supply System (UPS)

Be sure to shut down your OS (Windows® 2000 or Windows® XP) before turning off your machine. Also, use of an uninterrupted power supply is recommended to protect your data from accidental power failures.

An uninterrupted power supply that supports Windows® will give you sufficient time to shut down your system safely by changing into the power supply for the backup in case of a power failure, and can even be set up to automatically shut down your Windows® OS.

The PS-A unit, however, cannot be used with a 2-Step Inverter Output type uninterrupted power supply. Be sure the unit is a sine-output type power supply. For details, consult your local UPS system dealer.

Pro-face support site, "Otasuke Pro!" also supply the battery unit for PS-A. Visit "Otasuke Pro!" to download battery unit driver for PS-3650A series.

URL <http://www.pro-face.com/otasuke/>

5.4.3 Changing System Settings

Your Windows[®] system's configuration settings will need to be changed when the PS-A unit is connected to a LAN network or printer.

◆ Changing the System Configuration Settings

When the Windows[®] system configuration settings are changed, the following message appears. Enter the name of the folder where you will save the configuration changes and click [OK].

- Insert the CD labeled “Windows[®] xx*¹ Professional CD-ROM” in the CD-ROM drive (D:), and click [OK].
- When copying the file from other locations such as a floppy disk or network server, also click the [OK] button.

- When Your PS-A has No Preinstalled OS

Double-click the [I386] folder in the Windows[®] CD-ROM.

D:\I386 (When the CD-ROM drive is “D”)

- When Your PS-A has a Preinstalled OS

C:\Proface\Setup\I386

5.4.4 NTFS File System Conversion

If your OS is formatted with the Windows[®] DOS-compatible file system (FAT32), it can be converted to the NTFS file system.

To convert to the NTFS file system, start up Windows[®] and use the following command.

convert X: /fs:ntfs (Replace “X” with your drive name.)

NOTE

- Once the file system is converted to the NTFS file system, it cannot be converted back to the Windows[®] DOS-compatible file system (FAT32).

*1 “xx” is your OS.

Example) When using Windows[®] XP: “Windows[®] XP Professional CD-ROM”

6

PS-A Monitoring Features

1. RAS Features
2. Setting Menus
3. Monitoring the PS-A Status
4. Checking the Status of the PS-A Being Monitored
5. Checking the Error Log List
6. Monitoring Errors from a Remote Server
7. Restarting/Shutting Down the PS-A from a Remote Server
8. Setup Guide for the System Monitor Property
9. Setup Guide for the System Monitor Screen
10. Error Messages
11. Restrictions

This chapter describes various ways to monitor the status of the PS-A.

6.1 RAS Features

6.1.1 RAS Features

■ Errors which can be detected by RAS Features

RAS, which stands for Reliability, Availability, and Serviceability, is a device-level monitoring function that provides a variety of features to improve the reliability of your PS-A system.

Though the standard set of RAS features used will vary depending on the devices used, the following features are used to provide Alarm Monitoring and External Input Signal support.

NOTE

- For the setting procedures for the RAS features, refer to the following.

SEE →

6.8 Setup Guide for the System Monitor Property (page6-27)

<p>Alarm Monitoring</p>	<ul style="list-style-type: none"> • Power Voltage Alarm Monitors the status of the PS-A unit's built-in power supply and internal CPU power supply. • Cooling Fan RPM Alarm Monitors the CPU cooling fan RPM speeds. • Internal Temperature Alarm Monitors the internal temperature of the PS-A unit and the ambient temperature of the CPU. • Watchdog Timer Timeup • SMART Alarm Monitors the status of the hard disk. Detects a warning of trouble of the hard disk.
<p>External Input Signal</p>	<p>General Purpose Input ^{*1} (DIN 2-bit) Remote Reset Input ^{*2} (1 lamp)</p> <p>SEE → ◆ <i>External Input Signals (page6-5)</i></p>

*1: General Purpose Input will maintain Input Information.

*2: The remote reset feature's input can be either enabled or disabled, however, the setting of DOUT output state cannot be set to trigger a forced system reset.

IMPORTANT

- An administrator Authentication is required for executing SMART Monitoring.
- A CF card doesn't support SMART and therefore the status of the CF card cannot be monitored.
- When a hard disk except options made by Pro-face is used, the operation of SMART Monitoring cannot be guaranteed.

■ Error Notification

Also, when either the one of the above mentioned alarm occurs, or an external signal input is received, the following types of alarm processing output signals and features are supported by the PS-A.

<p>External Output Signal</p>	<p>General Purpose Output (DOUT 2-bit)</p> <p>SEE → ◆ <i>External Input Signals (page6-5)</i></p>
<p>Various Processing Functions</p>	<p>LED Indicator (2 colors, 1 lamp) The three-color LED on the front face is used to indicate the PS-A system conditions. It is also used as a power ON/OFF indicator.</p> <p>SEE → ◆ <i>LED Indicator (page6-5)</i></p> <p>Pop-up Message Output This feature displays the system status via a Windows® pop-up message.</p> <p>Buzzer Output This feature uses the PS-A unit's built-in speaker to alert the operator about the system status.</p> <p>System Shutdown This feature shuts down the PS-A unit's OS.</p> <p>System Reset This feature resets the system when the Watchdog Timer reaches "time up".</p>

Use the included System Monitor feature (utility software) to enable/disable the monitoring features and to set the alarm processing details.

SEE → *6.3 Monitoring the PS-A Status (page6-10)*

In addition, you can use the included dynamic link library (API-DLL) to access the RAS features from user-created applications.

SEE → *Otasuke Pro! "PS-A Reference Manual"*
URL <http://www.pro-face.com/otasuke/>

■ RAS Feature Overview

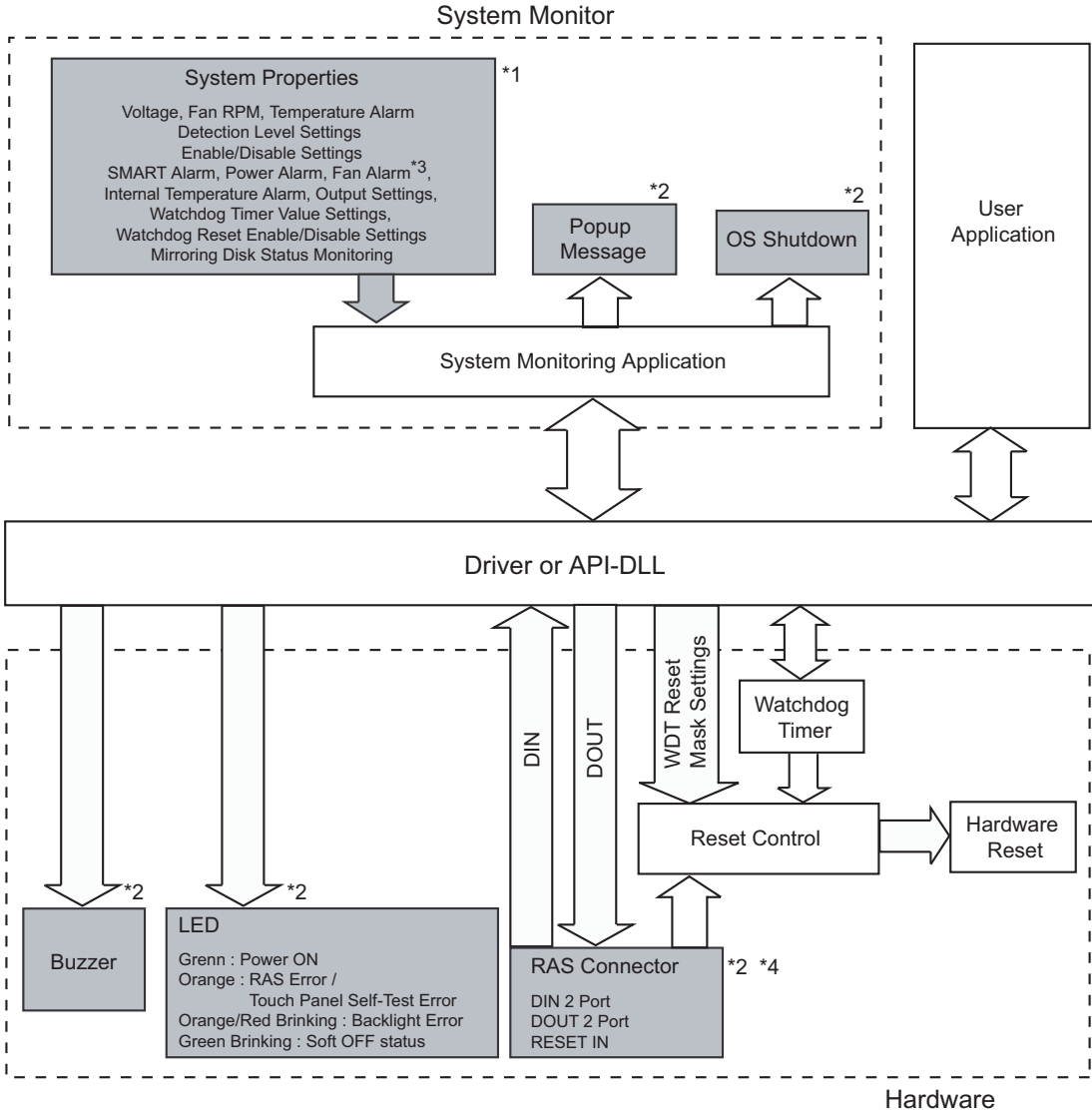

*1 Be sure to adjust these settings according to your system's specifications.

SEE → 6.3 Monitoring the PS-A Status (page6-10)

*2 Output via the RAS feature.

*3 The PS-3651A has no fans.

*4 DIN1 can be used as Reset Input. To do so, set it up in the System Monitor.

◆ LED Indicator

LED Color	System Status	Output Condition
Green (Lit)	Normal Operation (Power is ON)	None
Green (Blinking)	System is NOT running (Soft OFF)	None
Orange (Lit)	A RAS alarm has occurred.	LED is enabled via System Monitor Property.
	Touch Panel Self-Test Error	None
Not Lit	Power is OFF	-
Orange/Red (Blinking)	Backlight error	None

◆ External Input Signals

The PS-A’s RAS interface connector uses the following input signals.

- General Purpose Input (DIN 2 bits)

This standard digital input is used for alarm detection in external devices. The input signal uses two bits. The System Monitor property of the control panel or the API-DLL can be used to enable or disable this feature, as well as designate what type of processing is to be performed once a signal is received. (Only the “ON” state of the DIN circuit is detected. The “OFF” state of the DIN circuit cannot be monitored.)
- Remote Reset Input (Available with DIN1 only)

This is the reset signal sent from an external device to the PS-A. When this signal is enabled, a forced reset of the PS-A is performed.

The System Monitor property of the control panel or the API-DLL can be used to enable or disable this feature.

NOTE

- To enable Remote Reset Input, make sure to check the [Enable] in the [Remote reset] tab of System Monitor Property. For Remote Reset of System Monitor Property, refer to the following.

SEE → 6.8.4 Remote Reset (page6-31)

Input Voltage	DC12V to DC24V
Input Current	10mA
Operating Voltage	ON voltage: 10V (min), OFF voltage:3V (max)
Isolation Method	Via photocoupler

(Interface circuit)

No polar character
for sink source input

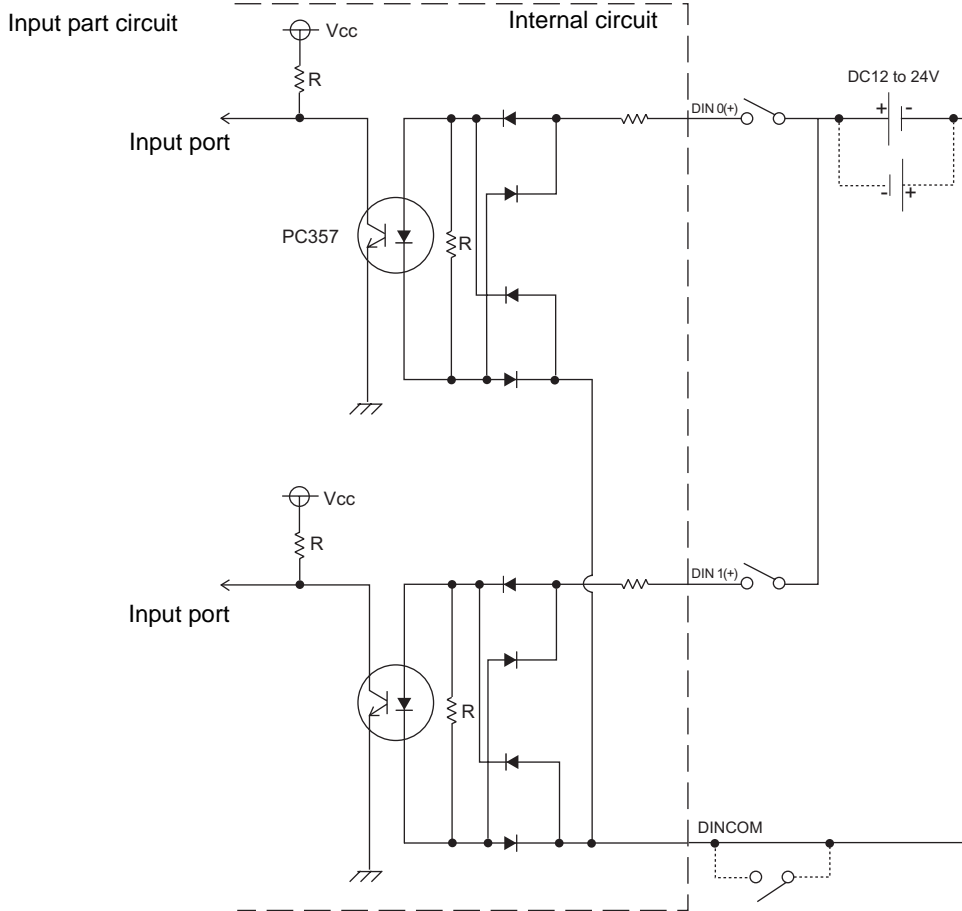

IMPORTANT

- General-Purpose Input (DIN) level must be 1.5 seconds or longer to be detected. It may not detect under 1.5 seconds.
- Be sure the voltage value between terminals is controlled via the input voltage, so that the PS-A is operated within its recommended range. If the input voltage exceeds this range, a malfunction or PS-A damage may occur.
- With Sink/Source input, even if the D(-), and RESET(-) are positive, and D(+), RESET(+) are negative, no problems are created. Be sure to operate the unit within the recommended voltage range.

NOTE

- For connection pin location details,
SEE → 2 Specifications (page2-1)

◆ External Output Signal

The PS-A’s RAS interface connector uses the following output signals.

- General Purpose Output (DOUT 2 bits)

This general purpose digital output signal provides system condition information to external devices.

The System Monitor property of the control panel or the API-DLL is used by applications to control this signal.

The above mentioned general purpose digital output signals provide system condition information to external devices.

The System Monitor property can be used to enable or disable any of these output signals.

Rated Load Voltage	DC24V
Maximum Load Current	120mA/point
Maximum Voltage Drop between Terminals	1.5V (at 100mA load current)
Isolation Method	Via photocoupler

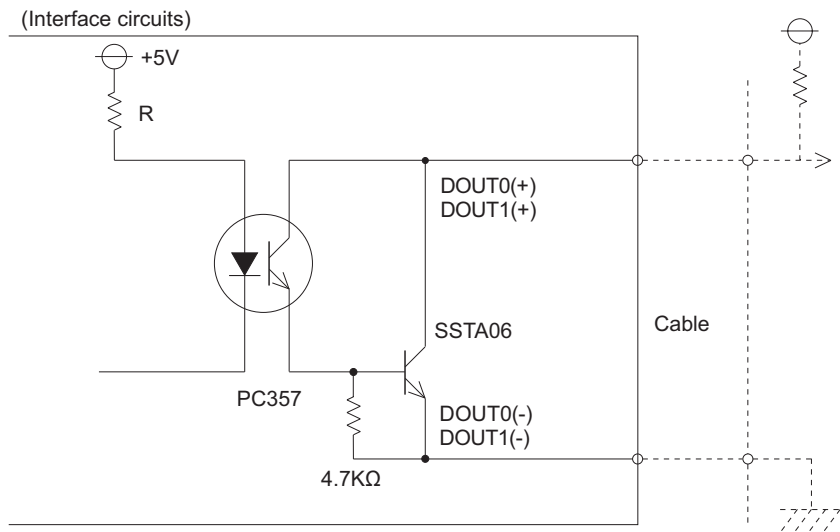

IMPORTANT

- Be sure to operate the unit within its maximum load current. If the maximum load current exceeds this range, a malfunction or PS-A damage may occur.
- Design your electrical system by adding the load current and voltage values to the terminal voltage. If load current value used is large, the voltage drop of 1.5V or less will occur between the terminals.
- When connecting an induction load, be sure to connect the above drawing’s protection diode (*1).

NOTE

- For connection pin location details, **SEE →** 2 Specifications (page2-1)

6.2 Setting Menus

Monitoring the PS-A Status

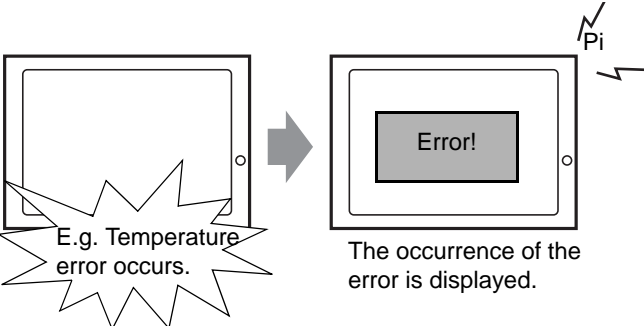

E.g. Temperature error occurs.

The occurrence of the error is displayed.

- ☞ Description (page6-10)
- ☞ Setup Procedure (page6-10)

Checking the Status of the PS-A Being Monitored

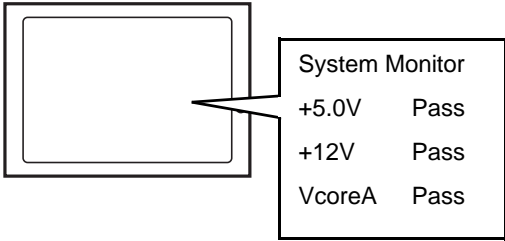

System Monitor	
+5.0V	Pass
+12V	Pass
VcoreA	Pass

- ☞ Description (page6-14)
- ☞ Setup Procedure (page6-14)

Checking the Error Log List

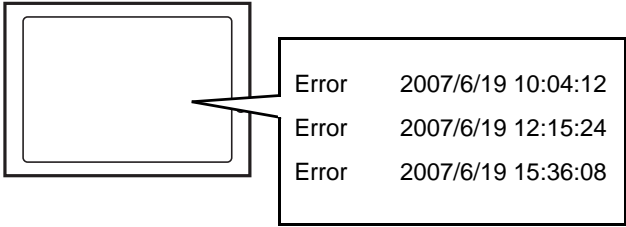

Error	2007/6/19 10:04:12
Error	2007/6/19 12:15:24
Error	2007/6/19 15:36:08

- ☞ Description (page6-15)
- ☞ Setup Procedure (page6-16)

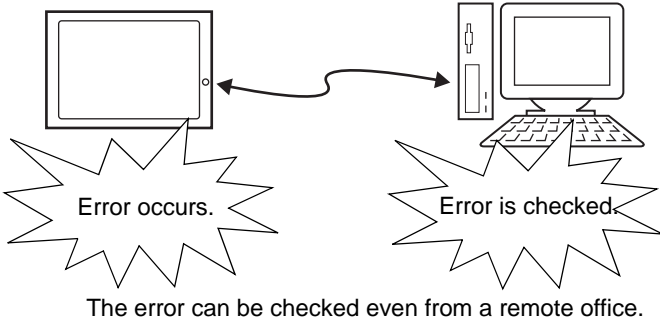
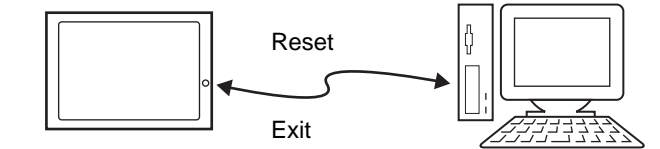
Monitoring Errors from a Remote Server	
<p>Using Pro-Server with Pro-Studio or via the network</p>  <p>The error can be checked even from a remote office.</p>	<ul style="list-style-type: none">➤ Description (page6-18)➤ System Configuration (page6-19)➤ Monitoring using Pro-Server with Pro-Studio or Pro-Server EX (page6-23)
Restarting/Shutting Down the PS-A from a Remote Server	
<p>Via the network</p>  <p>Remote operation from an office in a different location</p>	<ul style="list-style-type: none">➤ Description (page6-25)➤ Setup Procedure (page6-26)

6.3 Monitoring the PS-A Status

6.3.1 Description

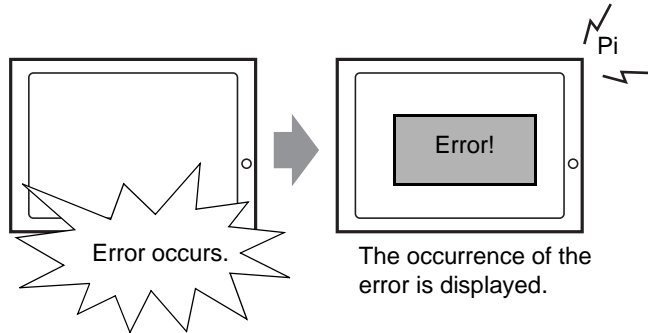

Before starting the setup procedure, specify the items you want to monitor with the RAS features.

When an error occurs, notification is provided according to the specified method.

6.3.2 Setup Procedure

- NOTE**
- For details about the setup procedure, refer to the Setup Guide.
- SEE →** 6.9 Setup Guide for the System Monitor Screen (page6-32)

This section describes the procedure to set the PS-A to monitor a temperature error and provide notification with a buzzer and pop-up message.

- Double-click [System Monitor Property] in [Control Panel] to display the [System Monitor Property] screen.
- Select the [Temperature] tab.

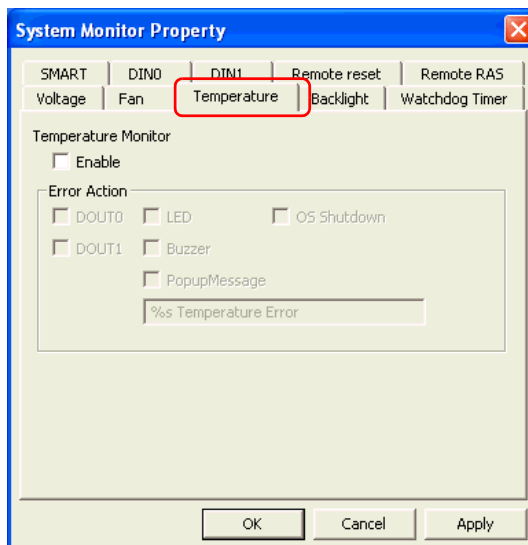

(3) Check [Enable].

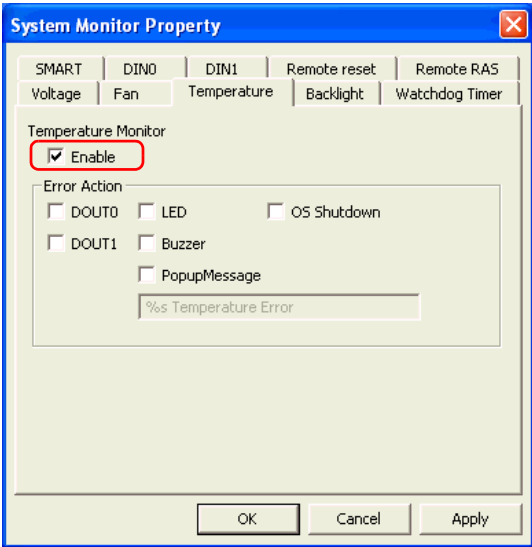

(4) For [Error Action], check [Buzzer] and [PopupMessage].

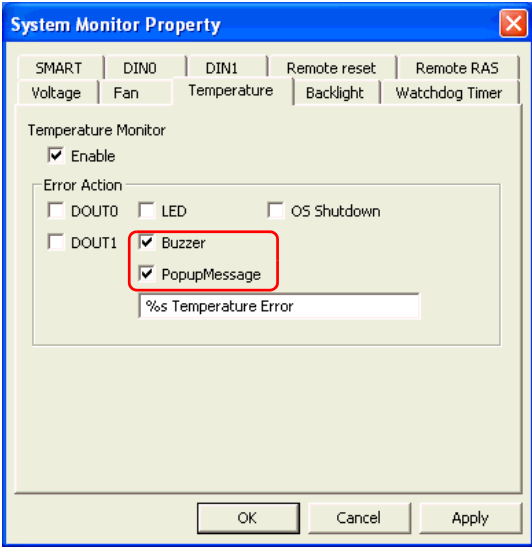

(5) Click [Apply].

(6) Click [OK] to complete the setting.

When the monitoring starts, the System Monitor icon appears in the task tray.

NOTE

- System Monitor also operates as Windows's Services. When System Monitor applications do not start, the System Monitor Service execute the RAS events setup in the System Monitor Property. You can check the System Monitor Service's operation state by selecting [Control Panel] -> [Administrative Tools] -> [Services].

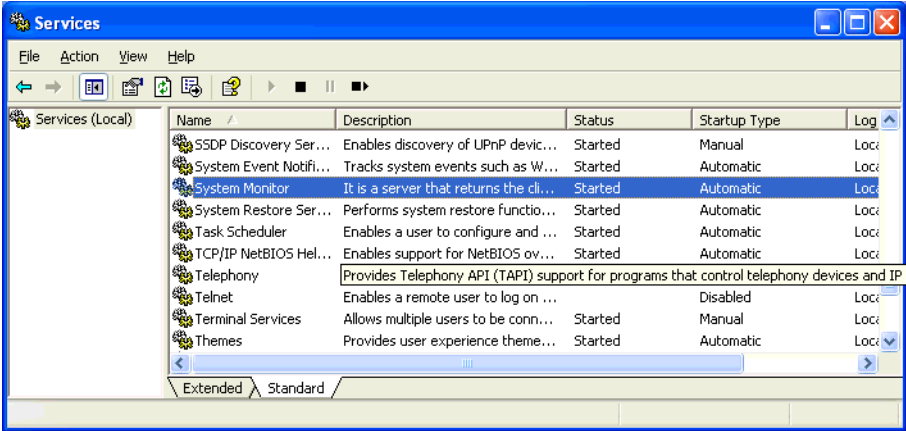

- The pop-up message displayed when the System Monitor Service detects an error differs from ordinary ones.



■ When an Error Occurs

- (1) A buzzer sounds and a pop-up message is displayed.

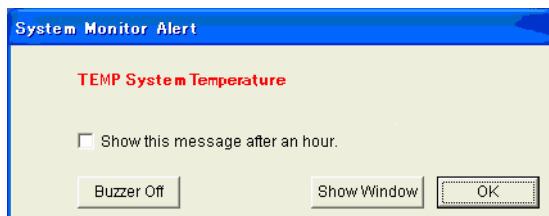

NOTE

- The Error Action is performed only one time when an error is detected for each monitoring item.
 - To stop the buzzer, click the [Buzzer Off] button in the pop-up message dialog box.
If the pop-up message is hidden, click the [Buzzer Off] button displayed in the System Monitor screen.
 - You can also display the [System Monitor] screen by pressing [Show Window] on the pop-up message window.
 - When you check the [Show this message after an hour] check box and press the [OK] button, the pop-up message window will close and will not open for an hour.
- (2) An “x” mark appears on the icon in the System Tray, which indicates an error status, and the icon blinks. You can see the description of the error by double-clicking the icon.

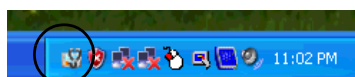

Icon display on start-ups

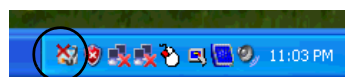

Icon display when an error is detected.

IMPORTANT

- Once an error is detected, the System Monitor holds the “error” status. (Icon display indicating error detection) To recover from the error status, press the [Reset] button on the System Monitor screen or turn off the PS-A. After that, perform maintenance service for removing the cause of the error factor, and then turn on the power again.

6.4 Checking the Status of the PS-A Being Monitored

6.4.1 Description

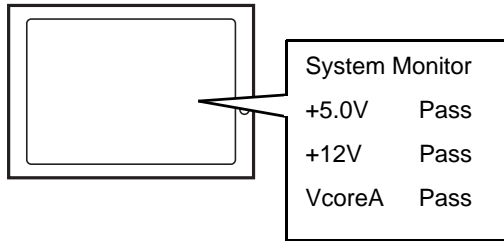

Check the status of the PS-A being monitored with the RAS features from the System Monitor screen.

You can also use this screen to check error details.

6.4.2 Setup Procedure

NOTE

- For details about the setup procedure, refer to the Setup Guide.



6.9 Setup Guide for the System Monitor Screen (page6-32)

- When the System Monitor starts, the System Monitor icon appears on the task bar. Double-click the System Monitor icon to display the System Monitor screen.

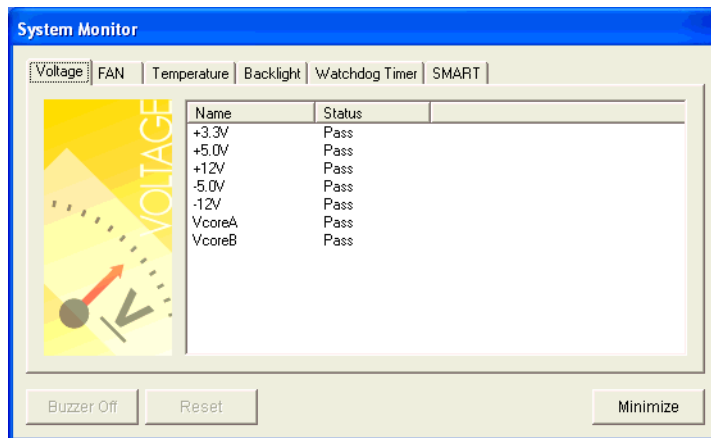

- Click the tab of the item you want to check.

NOTE

- When an error occurs, the color of the corresponding tab changes.
- As for Device No. of SMART, [0] means Master or HDD0 and [1] means Slave or HDD1.

6.5 Checking the Error Log List

6.5.1 Description

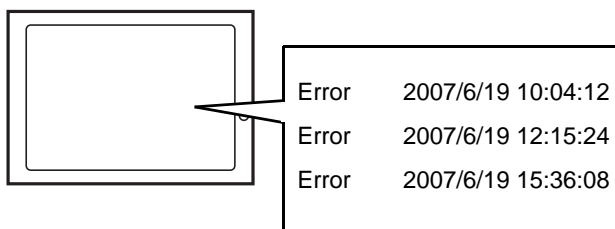

Check the location and action of the previous error on the Event Viewer screen.

6.5.2 Setup Procedure

- (1) Select [Control Panel] - [Administrative Tools] - [Event Viewer] to display the Event Viewer screen.
Select [System] to display the system log list.

NOTE • The Hardware Reset from a Watchdog Timer Error and the reset input for the RAS port cannot be logged.

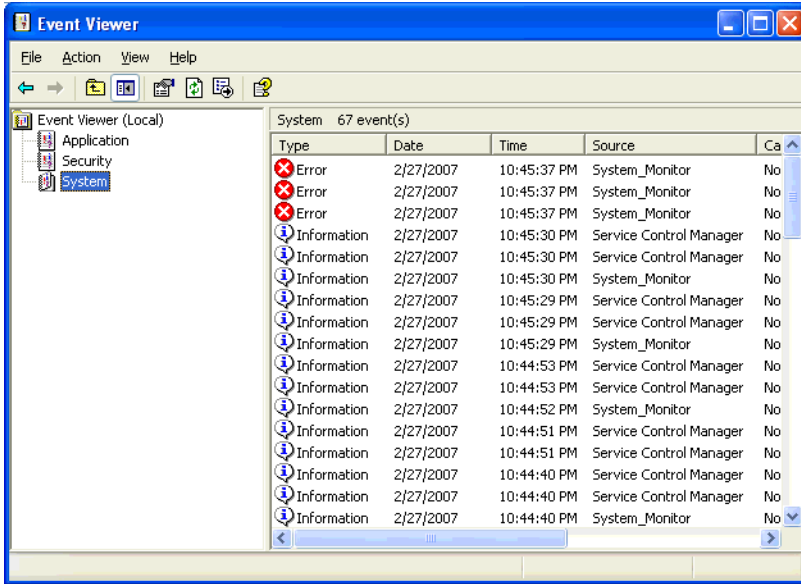

- (2) Error logs can be recognized by [System Monitor] displayed in the Source column.
Select the row of the error log you want to check and double-click it.

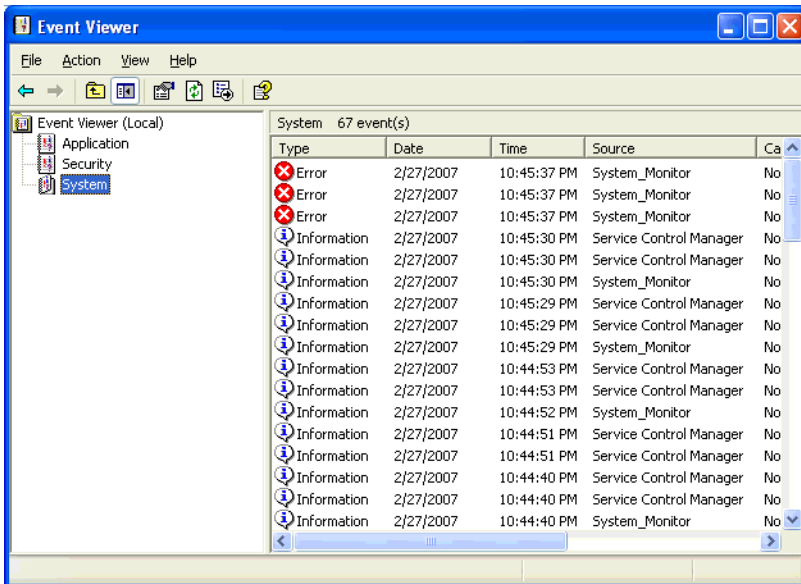

(3) The [Event Properties] screen appears.

The error message is displayed in the [Description] area.

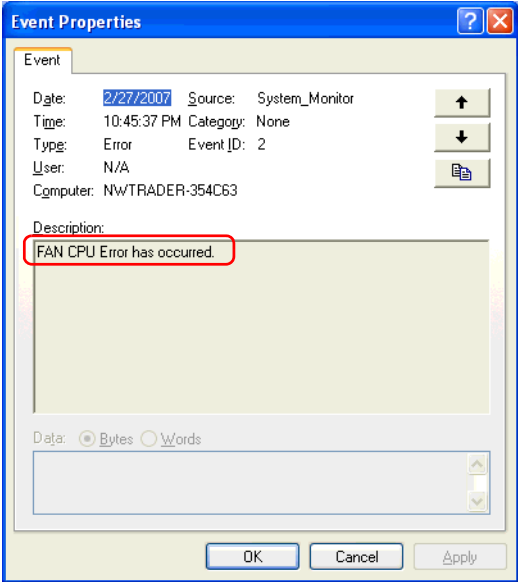

6.6 Monitoring Errors from a Remote Server

6.6.1 Description

Using Pro-Server with Pro-Studio or via the network

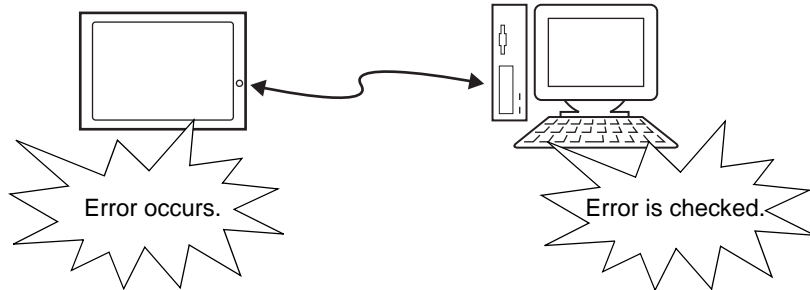

Monitor and control the System Monitor/RAS features remotely via the host PC in which Pro-face's Pro-Server with Pro-Studio (optional) or Pro-Server EX (optional) is installed.

To use this feature, you need Pro-Server with Pro-Studio Ver. 3.12 or higher, or, Pro-Server EX Ver.1.20 or higher. Please also refer to the manuals of the Pro-Server.

SEE → [6.6.3 Monitoring using Pro-Server with Pro-Studio or Pro-Server EX \(page6-23\)](#)

Even in an environment where Pro-Server with Pro-Studio is not installed on the host PC, the RAS monitoring is available via the network.

6.6.2 System Configuration

The system employing this feature is configured as illustrated below.

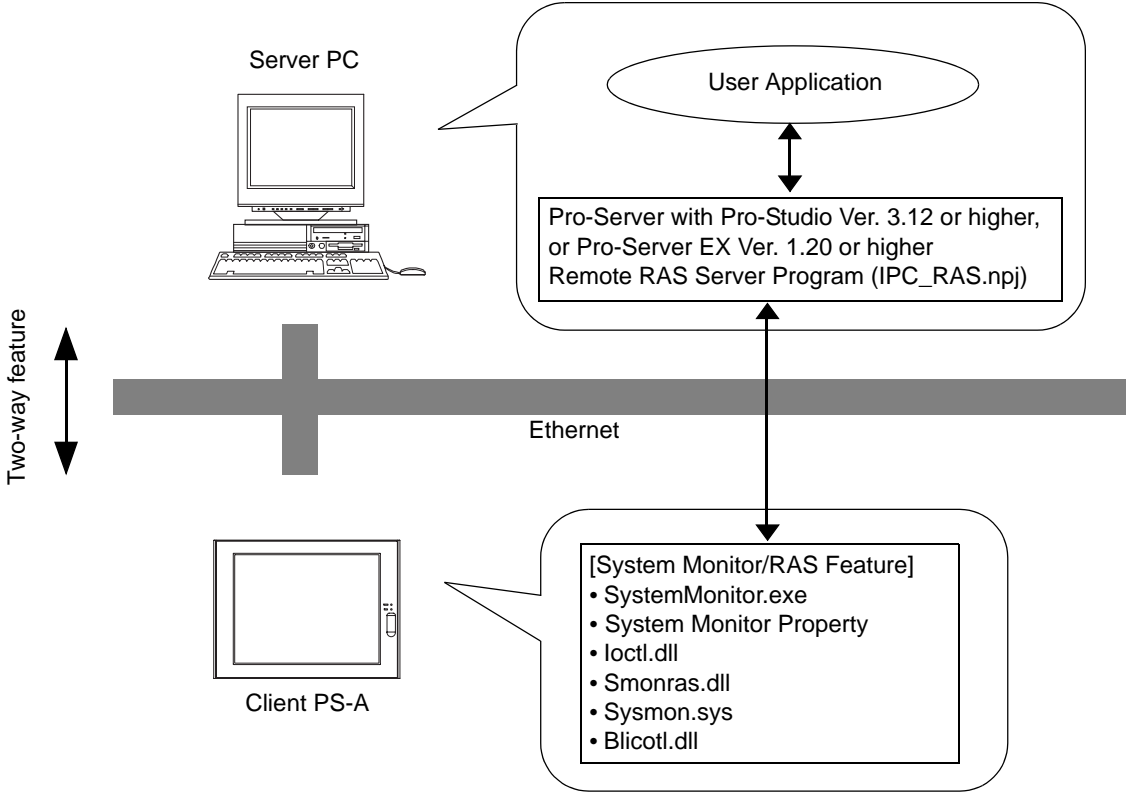

The status of the System Monitor/RAS feature is transferred to the Pro-Server via Ethernet from the System-Monitor.exe. The RAS feature including voltage, FAN, and temperature etc., can be monitored by monitoring the device addresses assigned from the Pro-Studio.

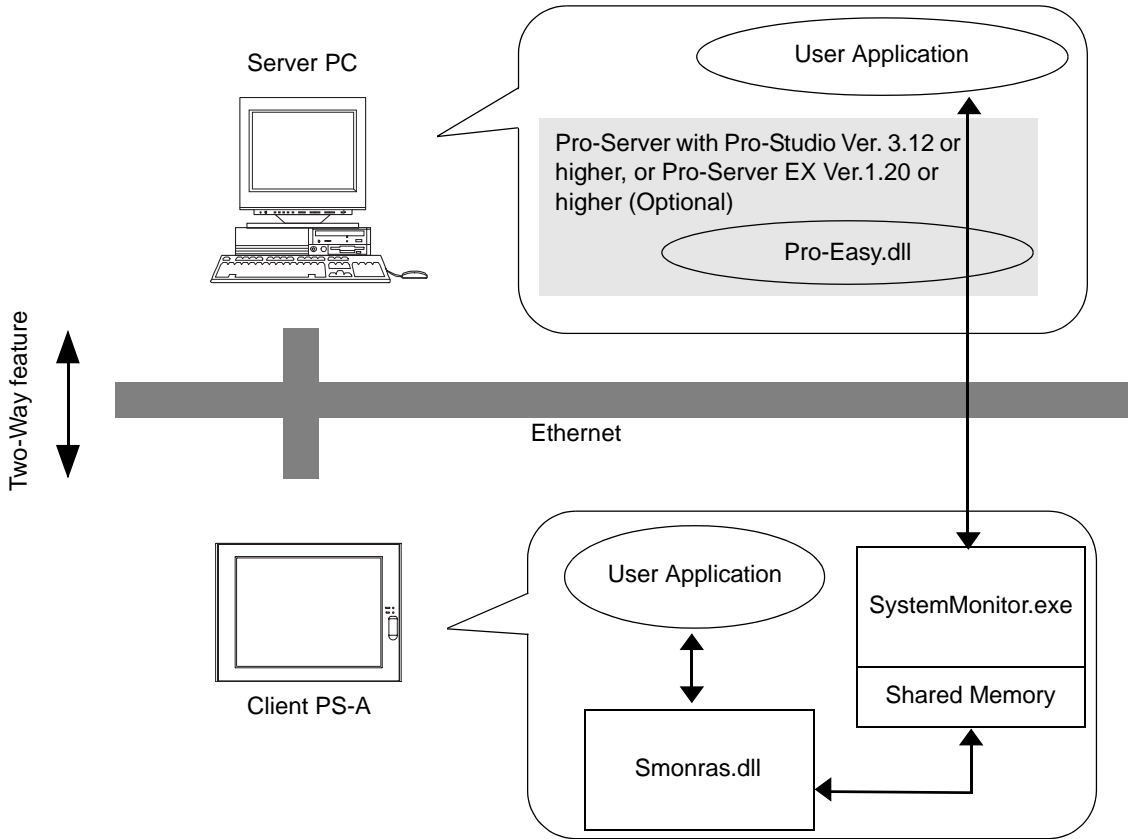

The user applications in the server PC monitors the RAS feature through the Pro-Easy.dll program provided from the Pro-Server.

The client PS-A shares the data with the user applications on the server PC by using the shared memory. The data transfers on both sides are processed via the Smonras.dll and Pro-Easy.dll programs.

■ List of Device Addresses

Device	Device Type	Device Symbol	Read/Write	Bit Access	16-bit Access	32-bit Access
VcoreA *1	WORD	VLT	Read	-	VLT0	-
VcoreB *1	WORD				VLT1	
+3.3V *1	WORD				VLT2	
+5V *1	WORD				VLT3	
+12V *1	WORD				VLT4	
+2.5V *1	WORD				VLT5	
-12V *1	WORD				VLT6	
Number of Revolution of CPU FAN *2	WORD	FAN			FAN0	
System Temperature *3	WORD	TMP			TMP0	
CPU Temperature *3	WORD		TMP1			
System2 Temperature	WORD		TMP2			
DIN	WORD	DIN		DIN00-DIN01	DIN0	
DOUT	WORD	DOUT	Read/Write	DOUT00-DOUT01	DOUT0	
Error Event	WORD	ERR	Read	ERR00-ERR10	ERR0 ERR1	
Internal Memory Area *4	WORD	LS	Read/Write	LS0000-LS0000F to LS02550-LS0255F	LS0000 to LS0255	LS0000 to LS0254
Shared Memory	WORD	PL		PL00000-PL0000F to PL02550-PL0255F	PL0000 to PL0255	PL0000 to PL0254
Software Reset Port *5	WORD	RST		-	RST0	-
Error Mask *6	WORD	ERRM	Read	ERRM00-ERRM10	ERRM0 ERRM1	-

*1 When monitoring the voltage with the device monitor, the unit is “mV”.

*2 When monitoring the number of revolutions with the device monitor, the unit is “rpm”.

*3 When monitoring Temperature with the device monitor, the unit is “°C”.

*4 Used for only the system to read/write the data and perform monitoring operation.

*5 Shuts down and restarts the operation system on the client PS-A.

*6 Indicates the error event that is being monitored by the PS-A.

IMPORTANT

- When “Forced Shutdown” or “Forced Reboot” is written to the device address, the system automatically shuts down/restarts the operation system without prompting the confirmation for saving the data on current applications.

Take extra cautions when performing write operation in order to avoid accidental data loss.

Value to be Written		Operation
Decimal Number	Hexadecimal Number	
1	0001	Shutdown
2	0002	Reboot
257	0101	Forced Shutdown
258	0102	Forced Reboot

■ Bit Assign of Error Event, and Error Mask

Device Name	Item	Bit
Error Event	VcoreA Voltage Error	ERR00
	VcoreB Voltage Error	ERR01
	+3.3V Voltage Error	ERR02
	+5.0V Voltage Error	ERR03
	+12V Voltage Error	ERR04
	+2.5V Voltage Error	ERR05
	-12V Voltage Error ^{*1}	ERR06
	System Fan Error ^{*1}	ERR08
	System Temperature Error	ERR0A
	CPU Temperature Error	ERR0B
	System2 Temperature Error	ERR0C
	Watchdog Timer Error	ERR0D
	Reserved	ERR0E
	Backlight Error	ERR0F
	SMART Error	ERR10
Error Mask	Vcore Voltage Error	ERRM00
	VcoreB Voltage Error	ERRM01
	+3.3V Voltage Error	ERRM02
	+5.0V Voltage Error	ERRM03
	+12V Voltage Error	ERRM04
	+2.5V Voltage Error	ERRM05
	-12V Voltage Error ^{*1}	ERRM06
	System Fan Error ^{*1}	ERRM08
	System Temperature Error	ERRM0A
	CPU Temperature Error	ERRM0B
	System2 Temperature Error	ERRM0C
	Watchdog Timer Error	ERRM0D
	Reserved	ERRM0E
	Backlight Error	ERRM0F
	SMART Error	ERRM10

*1: Nothing is displayed on PS-3651A.

6.6.3 Monitoring using Pro-Server with Pro-Studio or Pro-Server EX

■ Setting Up the Client PS-A

- (1) Double-click [System Monitor Property] in [Control Panel] to display the [System Monitor Property] screen.
- (2) On the [Remote RAS] tab, put a check mark in the [Enable] checkbox.

NOTE

- For details about the setup procedure, refer to the Setup Guide.

SEE → 6.8.2 Remote RAS (page6-29)

- In order to actually activate the Remote RAS feature, you are required to start up the System Monitor (SystemMonitor.exe) within the PS-A.
- (3) Click [Apply].

Click [OK] to exit the [System Monitor Property] screen.

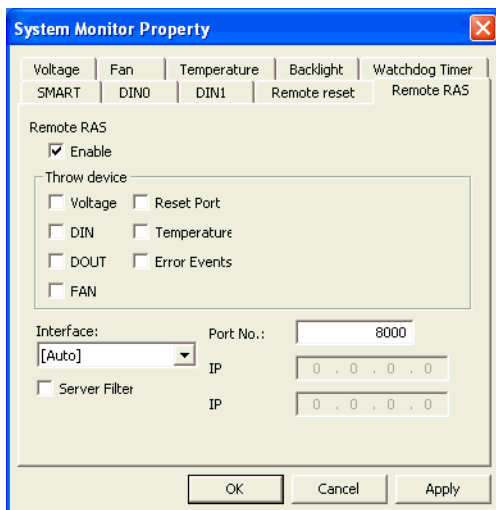

■ Setting Up the Server PC

- (1) On the server PC, download the software from the Pro-face support site “Otasuke Pro!”. Follow the attached instructions to copy the downloaded file to the designated file.
- (2) Start up the Pro-Studio.
- (3) Register the PS-A you want to include in the network to the network station, and edit the participant stations.

SEE →

Pro-Server with Pro-Studio for Windows Operation Manual
Pro-Server EX Reference Manual

NOTE

- When using the Pro-studio’s [Find Stations] command to register the PS-A to the network station, the System Monitor should be activated with the Remote RAS feature enabled in the PS-A.
- (4) Select [PL, PS-A, PS-B] for the PLC type on the network station editing.
 - (5) Register the symbol. Refer to the following for the symbols that can be registered.

SEE →

■ *List of Device Addresses (page6-21)*

NOTE

- You are not required to transfer the network project file created with the Pro-Studio to the client PS-A.

6.7 Restarting/Shutting Down the PS-A from a Remote Server

6.7.1 Description

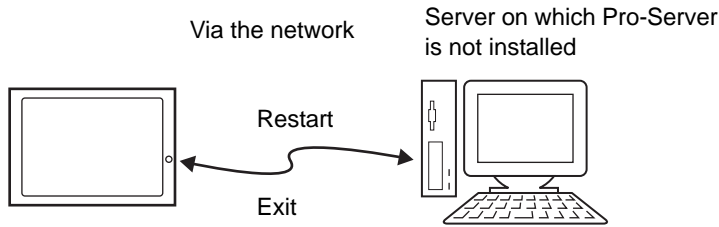

Restart or shut down the PS-A unit from a server on which Pro-Server is not installed.

The explanation given in this section assumes that the [Proface] folder has been created on drive C.

NOTE

- When using this function, LAN2 should be enabled. To enable LAN2, download the LAN driver from the Pro-face support site "Otasuke Pro!".

SEE → 5.3 *PS-A Dedicated Software (page5-6)*

- For the operation procedure of this feature, refer to the online help of the Remote Shutdown Application.
- Both applications (for server and client) can be installed on the PS-A to achieve self-control system. In such a case, however, the PS-A should be connected to a network.
- If the Remote Shutdown feature is executed, the PS-A unit will be in the Soft OFF Status. (Power is still supplied to a part of circuits.)

6.7.2 Setup Procedure

- (1) Execute the application on the server as well as on the PS-A.

The application is stored in the following folder.

	Application Name	File Name	Folder (Same for both Windows® XP and Windows® 2000)
Server	Remote Shutdown	RSSvr.exe	C:\Proface\Shutdown\Server
PS-A	Remote Shutdown	RSClt.exe	C:\Proface\Shutdown\Client

NOTE

- When the application does not exist, download the installer from the Pro-face support site "Otasuke Pro!".
<http://www.pro-face.com/otasuke/>

- (2) Check the IP address of LAN2 on the PS-A.
- (3) Shut down the OS of the PS-A. Make sure to keep the power supply to the PS-A.
- (4) Send MagicPacket from the server to the IP address of the PS-A checked in (2). Select the IP address to which you want to send the MagicPacket, right-click on the mouse, and select [Boot].

NOTE

- Download [Remote Shutdown], a tool to send the MagicPacket from the Pro-face support site "Otasuke Pro!".

- (5) The PS-A starts up.

■ Starting/Shutting Down the PS-A from the Standby or Sleep Mode

To start/shut down the PS-A from the standby or sleep mode, configuration of the [System] setting in the [Control Panel] is required.

NOTE

- To start/shut down the PS-A from the shut-down mode, it is not necessary to configure the [System] setting in the [Control Panel].

- (1) Start [Control Panel] from the Start menu.
- (2) Start the [System]. (You can find [System] in the Performance and Maintenance category.)
- (3) Start the [Device Manager] on the Hardware tab.
- (4) Double-click on [Realtek RTL8169/8110 Family] on the Network tab.
- (5) Put a checkmark to the [Allow this device to bring the computer out of standby] box on the Power Management tab.

6.8 Setup Guide for the System Monitor Property

The System Monitor Property allows you to specify PS-A items you want to monitor with the RAS features and the notification method used when errors occur.

When an error occurs, notification is provided according to the method specified in the System Monitor Property.

NOTE

- For procedure to set up the System Monitor Property, refer to the following section.

SEE → 6.3.2 Setup Procedure (page6-10)

- You can check the status of the PS-A unit you are monitoring with the RAS features on the System Monitor screen.

For details regarding the System Monitor screen, refer to the following.

SEE → 6.9 Setup Guide for the System Monitor Screen (page6-32)

The following table lists the operating settings that can be configured for each feature.

O: Setting available X: Setting not available

Feature	Operation						
	Buzzer	Popup Message	OS Shutdown	Reset	LED	DOUT 0-1	Timeout (sec):
Watchdog Timer	O	O	O	O	O	O	O
Voltage	O	O	O	X	O	O	X
Fan*1	O	O	O	X	O	O	X
Temperature	O	O	O	X	O	O	X
Backlight	O	O	X	X	O	O	X
SMART	O	O	X	X	O	O	X
DIN0-1	O	O	O	X	O	O	X
Remote Reset	O	X	X	X	X	X	X

*1: Nothing is displayed on PS-3651A.

IMPORTANT

- Administrator Authentication is required for executing SMART Monitoring. When a user who does not have the administrator authentication logs in, nothing is displayed in the item of SMART.

The following table lists the default settings of each feature.

O: Setting available X: Setting not available -: Not supported

Feature	Operation						
	Buzzer	Popup Message	OS Shutdown	Reset	LED	DOUT 0-1	Timeout (sec):
Watchdog Timer	X	O	X	X	O	X	O(5sec)
Voltage	X	O	X	-	O	X	-
Fan*1	X	O	X	-	O	X	-
Temperature	X	O	X	-	O	X	-
Backlight	X	O	-	-	O	X	-
SMART	X	O	-	-	O	X	-
DIN0-1	X	O	X	-	O	X	-
Remote Reset	X	-	-	-	-	-	-

*1: Nothing is displayed on PS-3651A.

6.8.1 Voltage / Fan / Temperature / Backlight / SMART / DIN0 / DIN1

- NOTE**
- The DIN1, Backlight, Voltage, Temperature, SMART, and Fan tabs display the same setting items as the DIN0 tab.
 - The FAN tab is not displayed on the PS-3651A.

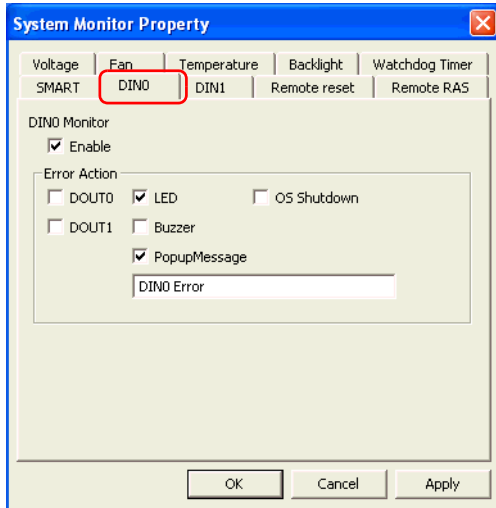

Item	Operation
Enable	When this option is checked, monitoring of the item starts.
Error Action	Specifies the action(s) taken when the System Monitor detects that the allowable range is exceeded. You need to check [Enable] before you can select actions.
	LED The front LED lights orange.
	Buzzer NOTE <ul style="list-style-type: none"> • Cannot be set up when a checkmark is put in the “OS Shutdown” checkbox.
	Pop-up Message When [PopupMessage] is specified as an action, the characters entered in the field (e.g. DINO Error) are displayed as a popup message. For the details about the PopupMessage feature, refer to the following section. SEE → ■ <i>When an Error Occurs (page6-13)</i>
	DOUT0 to 1 Output from the RAS port.
OS Shutdown NOTE <ul style="list-style-type: none"> • The shutdown confirmation message is not displayed. 	

6.8.2 Remote RAS

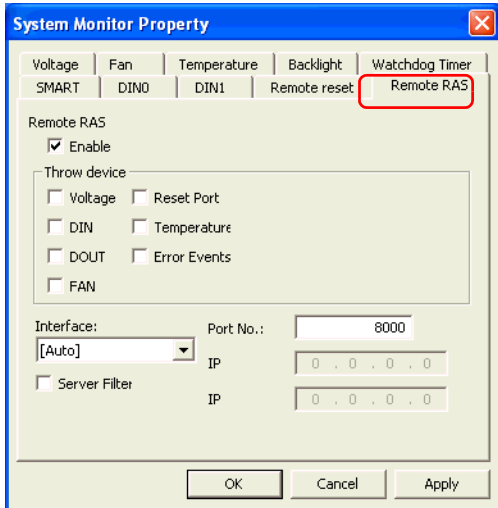

Item	Operation
Enable	When this option is checked, the remote RAS feature starts.
Throw device	Specifies the item(s) to be monitored.
Interface	Specifies the IP address used for the connection with the Pro-Server. NOTE <ul style="list-style-type: none"> When 2 or more IP Addresses are allocated to the PS-A unit, the [Auto] cannot be selected. Enter settings that allow the reading of a fixed IP Address from a DHCP server. For details, contact your company’s network administrator for getting the detailed information.
Server Filter	Check this option to communicate only with the server with a specific IP address.
Port No	Specifies the port No. of the server to communicate with.
IP	Specifies the IP address of the server to communicate with.

6.8.3 Watchdog Timer

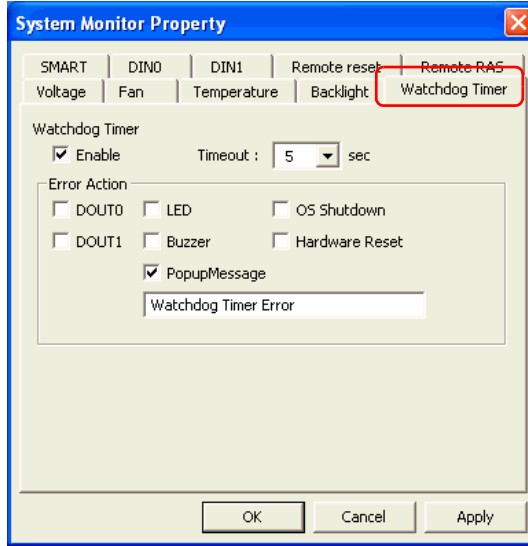

Item	Operation
Enable	When this option is checked, the Watchdog Timer is enabled.
Timeout (sec):	Specifies the timer duration.
Error Action	Specifies the action(s) taken when the System Monitor detects that the allowable range is exceeded.
Pop-up Message	When [PopupMenu] is specified as an action, the characters entered in the field (e.g. Watchdog Timer Error) are displayed as a popup message. For the details about the PopupMessage feature, refer to the following section. SEE → ■ <i>When an Error Occurs (page6-13)</i>

6.8.4 Remote Reset

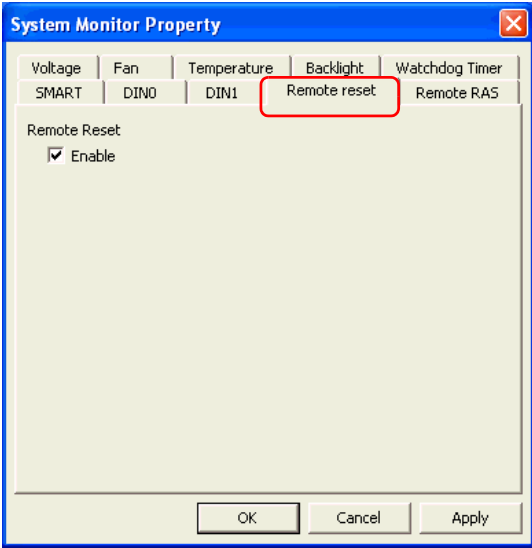

Item	Operation
Enable	When this option is checked, the Remote Reset is enabled.

6.9 Setup Guide for the System Monitor Screen

You can check the status of the PS-A being monitored.

Click the tab of the item you want to check.

NOTE

- PS-A items you want to monitor with the RAS features and the notification method used when errors occur are set from the System Monitor Property.

For the System Monitor Property settings, refer to the following.

SEE → *6.8 Setup Guide for the System Monitor Property (page6-27)*

6.9.1 Voltage / Fan / Temperature / Backlight / Watchdog Timer

- NOTE**
- The Temperature tab displays the same items as the Voltage tab.
 - The Backlight and Watchdog Timer tabs display [Status] only.
 - The FAN tab is not displayed on the PS-3651A.

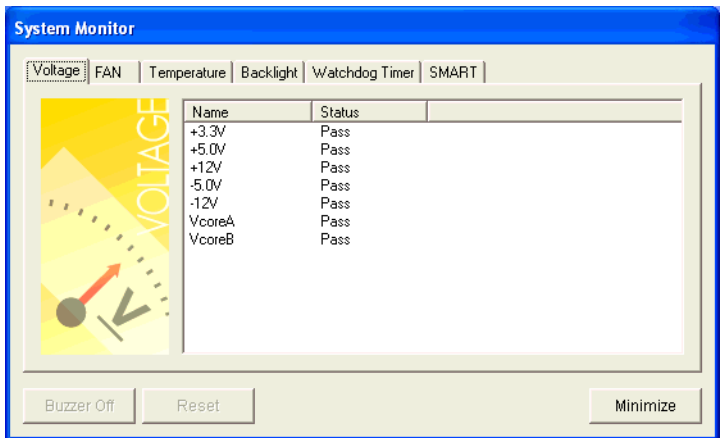

Item	Operation
Name	Displays the monitoring item.
Status	<p>Specifies the item to be monitored. The status of each monitoring item is displayed.</p> <p>[Pass]: Normal [Error]: Abnormal [Disable]: Not monitored</p> <p>NOTE</p> <ul style="list-style-type: none"> • When [Soft Mirror] is selected, different items are displayed. For details, refer to the manual of the Software Mirroring Utility.
Buzzer Off	When [Buzzer] is selected for the error notification method, you can stop the buzzer by clicking [Buzzer Off].
Reset	<p>When an error is detected, clicking [Reset] recovers the System Monitor from the “error” status.</p> <p>NOTE</p> <ul style="list-style-type: none"> • After an error is resolved, make sure to reset. If reset is not performed, the error history remains, which causes the error to be detected again even if it was resolved. For the procedure to recover from an error status, refer to the following section. <p>SEE → ■ <i>When an Error Occurs (page6-13)</i></p>
Minimize	Stores the System Monitor screen in the task tray.

6.9.2 SMART

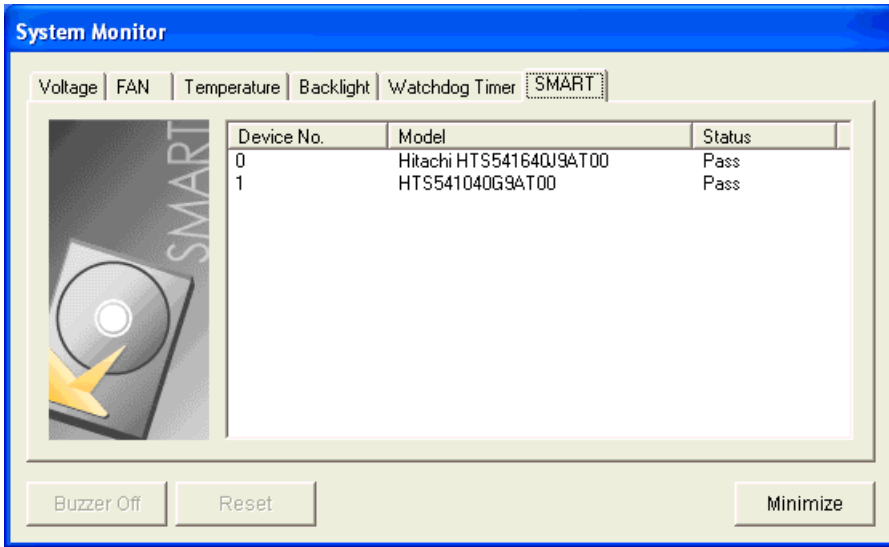

Item	Operation
Device No.	Displays the number assigned to the hard disk to be monitored.
Model	Displays the model of the hard disk.
Status	<p>Specifies the item to be monitored. The status of each monitoring item is displayed.</p> <p>[Pass]: Normal [Error]: Abnormal [Disable]: Not monitored [Not Support]: Not supported</p> <p>NOTE</p> <ul style="list-style-type: none"> [Not Support] is displayed when a device like a CF card, which does not support SMART, is detected.
Buzzer Off	When [Buzzer] is selected for the error notification method, you can stop the buzzer by clicking [Buzzer Off].
Reset	<p>When an error is detected, clicking [Reset] recovers the System Monitor from the "error" status.</p> <p>NOTE</p> <ul style="list-style-type: none"> After an error is resolved, make sure to reset. If reset is not performed, the error history remains, which causes the error to be detected again even if it was resolved. For the procedure to recover from an error status, refer to the following section. <p>SEE → ■ When an Error Occurs (page6-13)</p>
Minimize	Stores the System Monitor screen in the task tray.

6.10 Error Messages

■ Alarm Pop-up Messages

When an error occurs while the “Popup Message” option is enabled for Error Action, the following messages appear on the pop-up message output screen under the factory settings.

Error-generating Item	Message
VcoreA	“VcoreA Power Supply Error”
VcoreB	“VcoreB Power Supply Error”
+3.3V	“+3.3V Power Supply Error”
+5V	“+5V Power Supply Error”
+12V	“+12V Power Supply Error”
+2.5V	“+2.5V Power Supply Error”
-12V ^{*1}	“-12V Power Supply Error”
System FAN ^{*1}	“System FAN Error”
System Temperature	“System Temperature Error”
System2 Temperature	“System2 Temperature Error”
CPU Temperature	“CPU Temperature Error”
Watchdog Timer	“Watchdog Timer Error”
Backlight	“Backlight Blowout Error”
SMART	“SMART Error”

*1: Nothing is displayed on PS-3651A.

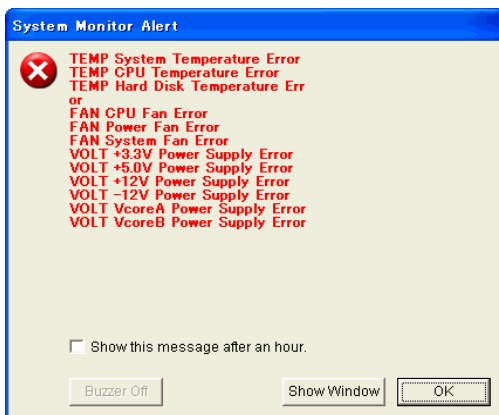

NOTE

- The messages displayed on the pop-up message output screen can be modified on the System Monitor Property.

SEE → 6.3.1 Description (page6-10)

■ Error Messages Displayed on the Event Viewer Screen

The error types/locations shown by the Event Viewer are as follows.

Error Type/Location	Error Message
Vcore A	Vcore A Error has occurred.
Vcore B	Vcore B Error has occurred.
+3.3V	+3.3V Error has occurred.
+5V	+5.0V Error has occurred.
+12V	+12V Error has occurred.
+2.5V	+2.5V Error has occurred.
-12V*1	-12V Error has occurred.
System FAN*1	FAN System Error has occurred.
System Temperature	System Temperature Error has occurred.
System2 Temperature	System2 Temperature Error has occurred.
CPU Temperature	CPU Temperature Error has occurred.
Watch Dog Timer	Watchdog Timer Error has occurred.
Backlight	Backlight Error has occurred.
SMART	SMART Error has occurred. Attribute (No.) (Attribute Name) Device (No.) (HD Model). The descriptions in the parentheses vary depending on details of occurring errors and the device where errors occur (0:Master, 1:Slave).

*1: Nothing is displayed on PS-3651A.

◆ Error Action

- NOTE**
- The data shown in the table's "□□" indicate the error type/location.
 - The actions to be taken after an error occurs are set via the System Monitor Property.

Error Action	Error Message
Buzzer	Buzzer has sounded because of □□ error.
Popup Message	Popup Message has been shown because of □□ error.
OS Shutdown	Window has been shut down because of □□ error.
LED	LED has output because of □□ error.

■ Error Messages Displayed during Device Reading/Writing

Error Code		Error Message
Decimal Number	Hexadecimal Number	
9530	253Ah	RAS Initialization Error
9531	253Bh	Command not supported.
9532	253Ch	Access type not supported.
9533	253Dh	Read/Write type not supported.
9534	253Eh	Access to the device is rejected.
9535	253Fh	Value setting to the device/retrieval failed.
65535 (No Code)	FFFFh	Returned when read/write of invalid values or unsupported device is performed for Voltage, Temperature, and number of revolution of the FAN.

SEE → For error messages other than listed above, refer to “Pro-Server with Pro-Studio for Windows Operation Manual”.

6.11 Restrictions

■ Supported Pro-Server Features

The following table lists the features of the Pro-Server that are supported by the PS-A. For the details of each feature, refer to “Pro-Server with Pro-Studio for Windows Operation Manual”.

Pro-Server Feature	O: Supported X: Not Supported
DDE Feature	O
Simplified DLL Feature (ProEasy.dll)	SEE → ■ Supported Simplified DLL Features (page6-38)
OPC Server Interface	O
SRAM Backup Data	X
Action Feature	X
Distribution Feature	X
Data Viewer	O ^{*1}
VBA Feature Assist	O
Device Data Backup/Restore Feature	O
Capture Screen Save Feature	X
Security Feature	O
Device Monitor	O
Status Monitor	X
Read Time Measurement	O

*1: Pro-Server with Pro-Studio for Windows Ver.4.0 or higher is required.

■ Supported Simplified DLL Features

The simplified DLL features supported by the PS-A are as follows:

- Direct Read Function
- Direct Write Function
- Cache Read Function
- Retrieval of Multithreading Handle
- Release of Multithreading Handle
- Loading of Network Project File
- Error Code String Conversion.
- Participant Station Status Readout Function
- Initialization of Simplified DLL
- Termination of Simplified DLL

NOTE

- Note that the PS-A-supported OS and features supported by Pro-Server are different.
- When using the Remote RAS feature together with Pro-Server in PS-A, be sure to select different port numbers.

7 | Maintenance

1. Cleaning the Display
2. Cleaning the Fan Filter
3. Periodic Inspection Items
4. Replacing the Installation Gasket
5. Replacing the Backlight
6. Replacing the Internal Battery

This chapter explains cautions and inspection criteria that will ensure trouble-free use of the PS-A.

7.1 Cleaning the Display

When the surface or frame of the display become dirty, soak a soft cloth in water with a neutral detergent, wring the cloth tightly, and wipe the display.

IMPORTANT

- Do not use paint thinner, organic solvents, or a strong acid compound to clean the unit.
- Do not use hard or pointed objects to operate the touch-screen panel, since it can damage the panel surface.

7.2 Cleaning the Fan Filter

In PS-3650A, the fan is used for cooling the CPU and the memory. Since excessive dirt and dust in the filter of the fan can potentially affect the performance of the unit, regular cleaning of the filter is strongly recommended.

- (1) Turn OFF the power switch of the PS-A and remove the power cable. Place the PS-A on a flat, level surface facing the display face downwards.
- (2) Unscrew the screws (2) (See the figure below) and remove the fan unit.

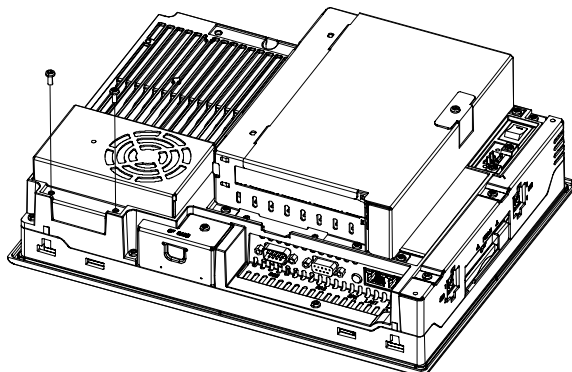

- (3) Turn the fan unit upside down. Unscrew the screw (1) and lift the fan. Remove the filter between the fan cover and the fan.

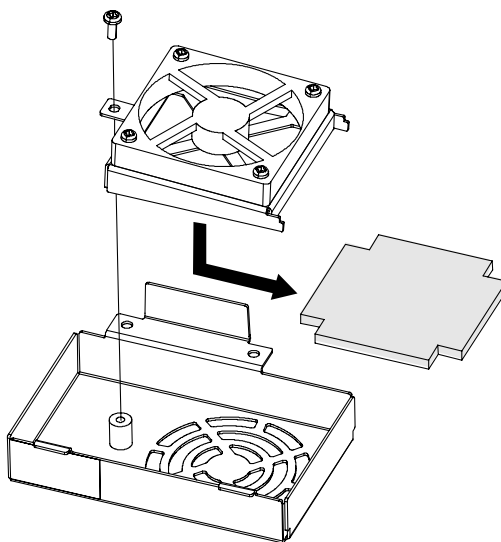

- (4) Remove dust on the filter using a cleaner etc. If stubborn dirt or stains are present, wash the filter with a neutral detergent.

IMPORTANT

- Do not wring the filter to dry it.

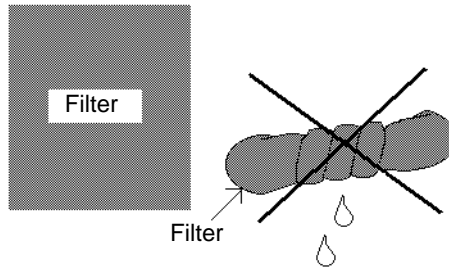

- When drying the filter, dry it without exposing it to direct sunlight.
 - Dry the filter completely before reattaching it.
- (5) Install the filter and tighten the screws of the fan cover.
- (6) Install the fan unit in the PS-A unit.

IMPORTANT

- Be sure the fan cover is securely attached to the PS-A unit. This is to ensure the fan cover does not fall while the PS-A unit is operating.
- When installing the fan unit in the PS-A unit, keep the cable as left as possible seen from the back surface of the PS-A unit, so that the fan cannot contact with it.

7.3 Periodic Inspection Items

Be sure to inspect the PS-A periodically to ensure it is in good working condition.

■ Ambient environment check

- Is the ambient temperature within the specified range?

(PS-3650A)

When using HDD	When not using HDD
5 to 50°C	0 to 50°C

(PS-3651A)

When using HDD	When not using HDD
5 to 45°C	0 to 50°C

- Is the ambient humidity within the specified range?

PS3650A/PS3651A: 10 to 90%RH (Not condensing, wet bulb temperature: 39°C or less, or with HDD 29°C or less.)

- Is the atmosphere free of corrosive gas?

When using the unit in an enclosure, the enclosure's atmosphere is the ambient environment.

■ Electrical specifications check

- Is the voltage adequate?

PS3650A-T41/PS3651A-T41: AC85 to 265V, 50/60Hz

PS3650A-T41-24V/PS3651A-T41-24V: DC19.2 to 28.8V

■ Installation check points

- Are all power cords and cables connected properly? Have any become loose?
- Are all mounting brackets holding the unit securely?
- Are there scratches or traces of dirt on the installation gasket?

■ Display check

- Is the display bright enough?

NOTE

- If the PS-A's backlight needs to be replaced, please contact your nearest authorized service center for prompt service.

7.4 Replacing the Installation Gasket

The installation gasket provides protection against dust and moisture.

IMPORTANT

- A gasket which has been used for a long period of time may have scratches or dirt on it, and could have lost the moisture resistance to be equivalent to IP65f. when installing the PS-A removed from the enclosure again, the moisture resistance to be equivalent to IP65f may go down. Be sure to change the gasket at least once a year, or when scratches or dirt become visible.
- The PS-A unit installation gasket's model number is CA3-WPG12-01.

■ Installation Gasket Attachment Procedure

- (1) Place the PS-A on a flat, level surface facing the display face downwards.
- (2) Remove the gasket from the PS-A.
- (3) Attach the new gasket to the PS-A. Be sure to insert the gasket into the PS-A's groove so that the gasket's groove sides are vertical.

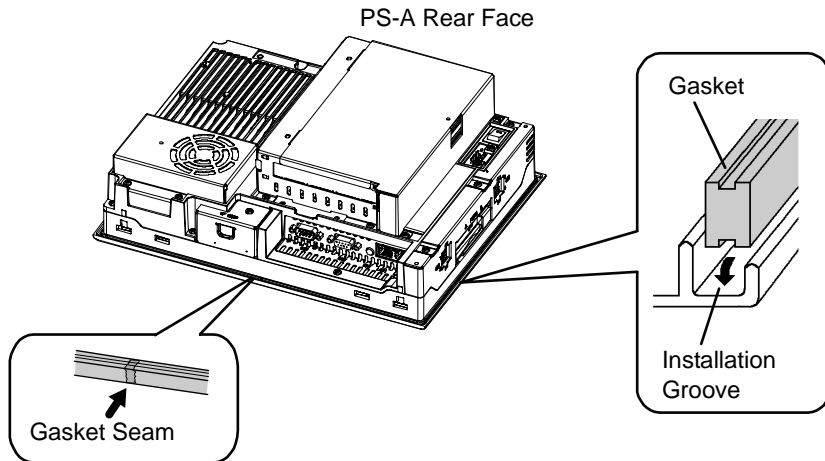

- (4) Check that the gasket is attached correctly to the PS-A. The upper surface of the gasket should protrude approximately 2 mm [0.08 in.] out of the groove evenly.

Unit:mm [in.]

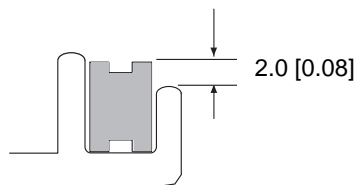

IMPORTANT

- Be sure to confirm the condition of installation of the gasket when you install the unit in the panel. The gasket must be inserted correctly into the groove for the PS-A's moisture resistance to be equivalent to IP65f.
- Since the gasket is flexible but not elastic, be careful not to stretch it unnecessarily, as doing so could tear the gasket.
- Be sure the gasket's seam is not inserted into any of the unit's corners, only in the straight sections of the groove. Inserting it into a corner may lead to its eventually tearing.
- To ensure stable resistance against dust and moisture, insert the gasket so that the seam is at the bottom of the PS-A unit.

7.5 Replacing the Backlight

PS-A units use a CFL, long-life type backlight. The actual life of the backlight however, will vary depending on the PS-A's operating conditions. It is recommended that it be replaced periodically. A PS-A backlight has a life of 50,000 hours (approx. 5.7 years, at 25°C and 24 hour operation), when the backlight is lit continuously (time required for brightness to fall to half its normal level.)

NOTE

- When the LED setting is specified with the RAS control in Control Panel and a backlight burnout is detected, the status LED illuminates in orange.
- If the backlight or the display unit is damaged, the screen display will go out. Even if the screen goes out, however, there is a possibility that the touch panel is still operating correctly. Therefore, since any type of touch panel contact could have an unexpected or dangerous effect or result, be sure not to touch the screen when this condition occurs.
- A backlight burnout is detected by monitoring the consumed current. Depending on the condition of the backlight, a backlight burnout may not be detected or it may be detected before the backlight burns out completely.

WARNING

- ❗ Whenever changing the backlight, be sure the PS-A's power cord has been disconnected and that the unit is cooled down.
- ❗ High voltage runs through the wires in the backlight area. When the PS-A's power cord is connected and the PS-A is ON, do not touch the area!
- ❗ When the PS-A's power has just been turned OFF, the backlight area is still very hot! Do not touch the backlight area until the area is cooled down. Be sure to wear gloves to prevent being burned.
- ❗ The backlight is very fragile. Do not strongly push the glass tube or do not strongly pull it when replacing the Backlight. If the glass tube breaks, you may be injured.

■ Preparation

Please have the following ready beforehand.

- Replacement backlight (Model:CA5-BLU12XGA-01)
- One pair of clean (preferably new) cotton gloves.
- Phillips screwdriver (no.2)

7.5.1 Procedure for replacing the backlight of PS-3650A

Be sure to wear gloves when exchanging the backlight, and follow the following procedures.

- (1) Turn OFF the power switch of the PS-A and remove the power cable.
- (2) Remove the PS-A unit from the equipment (panel etc.) to which the unit has been incorporated, and place the PS-A unit on a flat, level surface facing the display face downwards.

IMPORTANT

- Be sure to perform the backlight changeover on a flat, level surface. This will prevent damage to the PS-A unit and the accidental cutting of any of its power cord.
 - Be sure to protect the display surface to prevent damage during the operations.
- (3) Unscrew the screws (2) of the Expansion Board Cover, and remove the Cover.

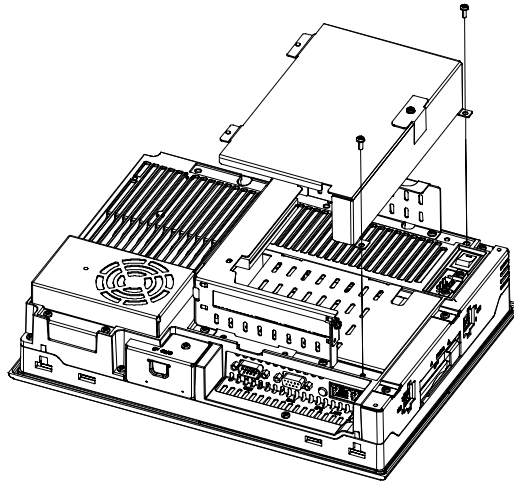

NOTE

- When using the PCI board, it is required to remove the Expansion Board Support first. Then remove the Expansion Board Cover and the PCI board.
- (4) Unscrew the screws (3) of the Mask Cover and remove the Cover.

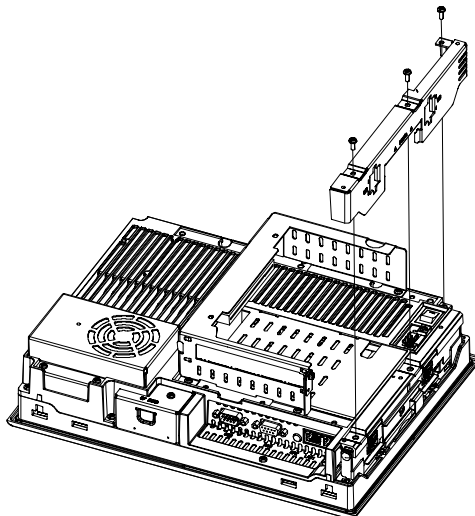

- (5) Unscrew the screws (6) (See the figure below).

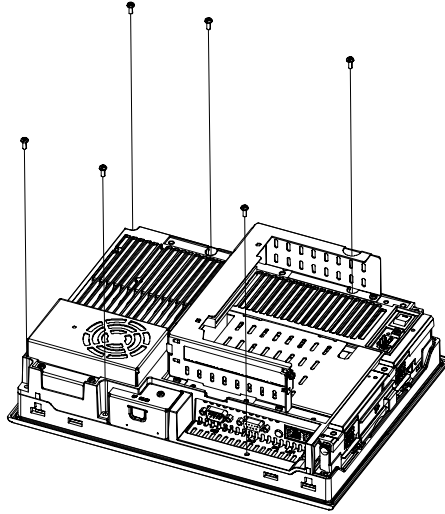

- (6) Open the PS-A unit as the figure below indicates.

Backlight Unit

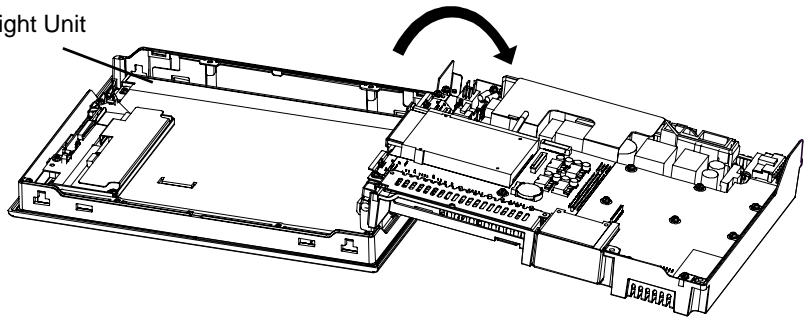

- (7) Disconnect the Backlight Unit cable from the connector on the inverter board, and then remove the cable from the cable clamp.

Cable Clamp

Connector

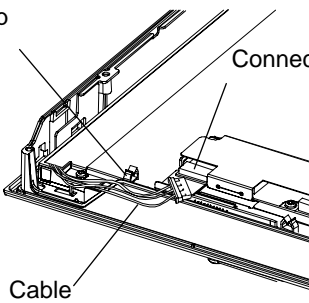

- (8) Loosen the Backlight Unit setscrew (1), and lift the edge of the Backlight Unit, and remove the unit while sliding it along the groove.

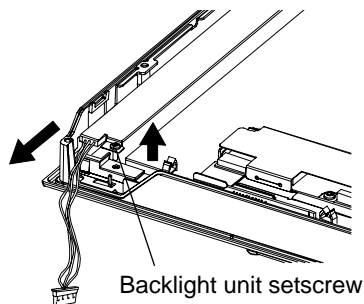

- (9) Insert a new Backlight Unit while sliding it along the groove and fasten the setscrew. The necessary torque is $0.173\text{N}\cdot\text{m}$.

IMPORTANT

- Be careful that no dust or dirt adheres to the backlight surface or to the backlight holder.
- Be careful not to soil the Backlight with moisture, oil content or finger prints; otherwise, the life duration of the Backlight will be shortened.

- (10) Insert the Backlight Unit cable to the connector on the inverter board, and secure the cable with the cable clamp.

IMPORTANT

- Be sure the cable is inserted completely into the backlight connector. Failure to do so may cause accidents, which can damage the connector.
- The cable clamp is used to prevent the cable from being caught inside in the PS-A unit and possibly damaged. Be sure to insert the cable in the cable clamp around the cable before closing the PS-A unit.

- (11) Return the PS-A unit to the original condition and tighten the screws (6).

IMPORTANT

- If any of the screws is missing, check if it fell inside the PS-A unit's chassis. If the power is turned ON while a screw is inside, it may cause an accident or fire.

- (12) With the reverse procedures to de-installation, install the Mask Cover and the Expansion Board Cover, sequentially. The necessary torque is $0.5\text{N}\cdot\text{m}$ to $0.6\text{N}\cdot\text{m}$.

NOTE

- After backlight replacement is completed, turn the PS-A unit's power ON and check if the screen's display is normal. If the display is not correct, please contact the Pro-face distributor from whom you purchased the backlight unit.

7.5.2 Procedure for replacing the backlight of PS-3651A

Be sure to wear gloves when exchanging the backlight, and follow the following procedures.

- (1) Turn OFF the power switch of the PS-A and remove the power cable.
- (2) Remove the PS-A unit from the equipment (panel etc.) to which the unit has been incorporated, and place the PS-A unit on a flat, level surface facing the display face downwards.

IMPORTANT

- Be sure to perform the backlight changeover on a flat, level surface. This will prevent damage to the PS-A unit and the accidental cutting of any of its power cord.
- Be sure to protect the display surface to prevent damage during the operations.

- (3) Unscrew the screw (3) of Master Cover, and remove the Mask Cover.

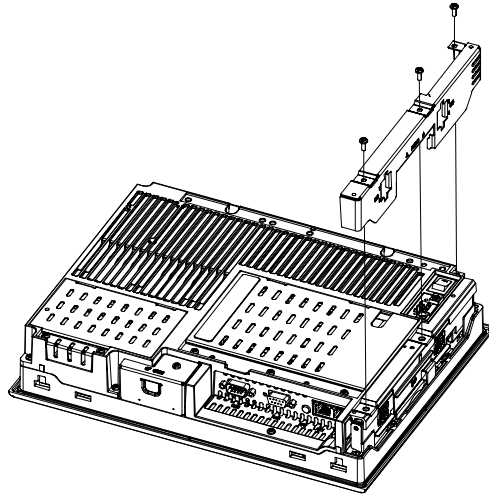

- (4) Unscrew the screws (6) (See the figure below).

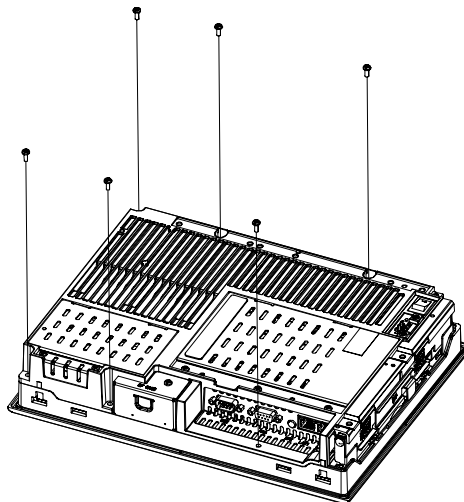

- (5) Open the PS-A unit as the figure below indicates.

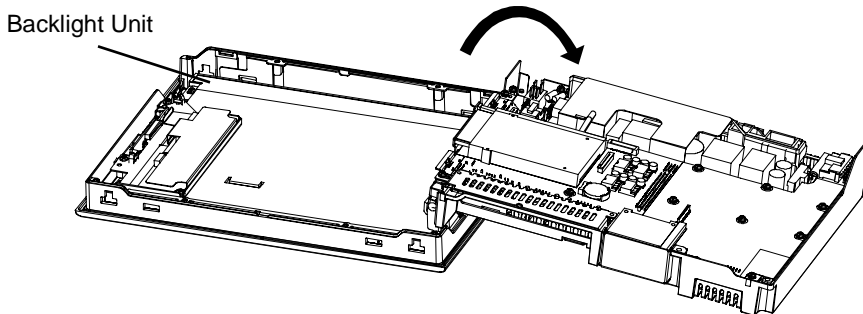

- (6) Disconnect the Backlight Unit cable from the connector on the inverter board, and then remove the cable from the cable clamp.

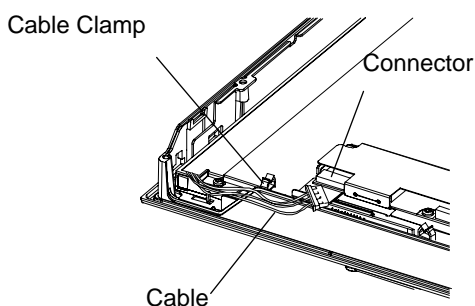

- (7) Loosen the Backlight Unit setscrew (1), and lift the edge of the Backlight Unit, and remove the unit while sliding it along the groove.

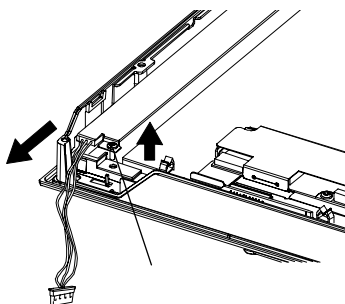

- (8) Insert a new Backlight Unit while sliding it along the groove and fasten the setscrew. The necessary torque is $0.173\text{N}\cdot\text{m}$.

IMPORTANT

- Be careful that no dust or dirt adheres to the backlight surface or to the backlight holder.
- Be careful not to soil the Backlight with moisture, oil content or finger prints; otherwise, the life duration of the Backlight will be shortened.

- (9) Insert the Backlight Unit cable to the connector on the inverter board, and secure the cable with the cable clamp.

IMPORTANT

- Be sure the cable is inserted completely into the backlight connector. Failure to do so may cause accidents, which can damage the connector.
- The cable clamp is used to prevent the cable from being caught inside in the PS-A unit and possibly damaged. Be sure to insert the cable in the cable clamp around the cable before closing the PS-A unit.

- (10) Return the PS-A unit to the original condition and tighten the screws (6).

IMPORTANT

- If any of the screws is missing, check if it fell inside the PS-A unit's chassis. If the power is turned ON while a screw is inside, it may cause an accident or fire.

- (11) Put the Mask Cover back in place and tighten the screws (3).The necessary torque is 0.5N•m to 0.6N•m.

NOTE

- After backlight replacement is completed, turn the PS-A unit's power ON and check if the screen's display is normal. If the display is not correct, please contact the Pro-face distributor from whom you purchased the backlight unit.

7.6 Replacing the Internal Battery







The PS-A unit has an internal battery for backup of internal clock data.

Compatible Battery	Service Life
Lithium Battery CR2032 (Hitachi Maxell, Ltd.)	5 years

IMPORTANT

- The expected battery service life is 5 years, however the battery may die before then. It is strongly recommended that you replace the battery regularly.
- When the battery is replaced, a part of the BIOS settings are initialized. Configure the BIOS settings again after replacing the battery.

CAUTION

-  There is a danger of explosion if the PS-A unit's battery is incorrectly replaced. This battery should be replaced with equivalent type recommended by Pro-face.
-  Prior to replacing the battery, be sure to turn OFF the PS-A unit's power.
-  Be careful not to cause a short circuit.
-  Do NOT touch any internal parts except the battery and the battery holder.
-  During the replacement, be extremely careful not to drop the battery onto the PC board inside the PS-A unit. This may cause product failure.
-  Dispose of used batteries according to the battery manufacturer's instructions.

■ Battery Replacement Procedure

The battery is on the PC board inside the PS-A unit. Refer to “7.5 Replacing the Backlight” for how to open the PS-A unit.

- SEE →** 7.5.1 Procedure for replacing the backlight of PS-3650A (page7-9)
7.5.2 Procedure for replacing the backlight of PS-3651A (page7-12)

- (1) Be sure to confirm that power is not supplied to the PS-A unit and open the unit.

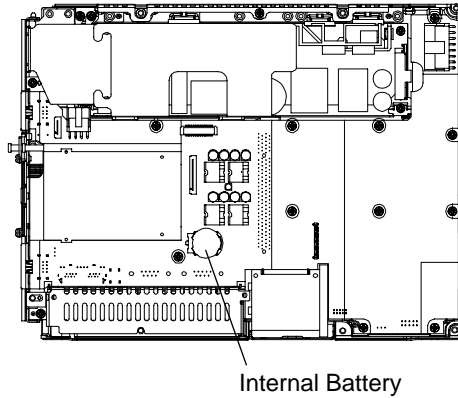

- (2) Remove the battery. Push the clip of the battery holder with your finger, the forceps etc. and the battery is pushed up and removed.

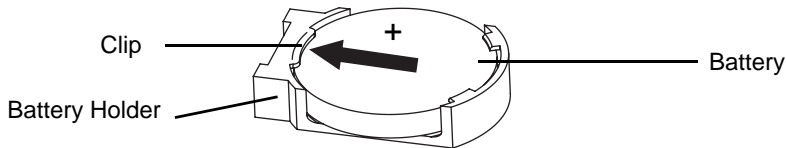

- (3) Insert the new battery. Insert the battery in the side of the clip of the battery holder first with the plus pole (+) facing upward. Push the battery from above until you hear the click to fit it in the battery holder.

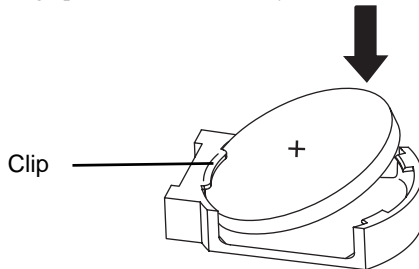

IMPORTANT • Be sure the battery's plus(+) and minus(-) sides are correctly oriented.

- (4) Return the PS-A unit to the original condition.

IMPORTANT • Be sure to adjust the time of the internal clock after replacing the battery.

8

Troubleshooting

1. Problems and Countermeasures
2. Recovery Procedure

This chapter describes the countermeasures for problems with the PS-A and the recovery procedure for the OS.

8.1 Problems and Countermeasures

Problem	Countermeasure and reference page
<p>Nothing appears on the screen.</p>	<p>Is the power cable connected properly?</p> <p>SEE → 3 <i>Hardware Installation (page3-1)</i></p>
	<p>Is the power supply/voltage within the range of the specifications?</p> <p>SEE → 2.1 <i>General Specifications (page2-2)</i></p>
	<p>Is the backlight lit? If the backlight is burnt out, replace it.</p> <p>SEE → 7.5 <i>Replacing the Backlight (page7-8)</i></p>
	<p>Does the status LED illuminate in green?</p> <p>SEE → <i>If the status LED does not illuminate, contact your local PS-A distributor.</i></p> <p>Is the image output cable connected correctly? Did you reconnect the image output cable and restart the PS-A unit? Did you disconnect the image output cable after starting the PS-A unit? - If the OS setup is not yet completed Connect the image output cable correctly, and recover the OS using the Recovery Media. - If the OS setup is completed</p> <ul style="list-style-type: none"> • If the analog RGB cable is connected correctly → Hold down [Ctrl] + [Alt] + [F1] at the same time for 1 second or longer. • If the DVI cable is connected correctly → Hold down [Ctrl] + [Alt] + [F4] at the same time for 1 second or longer.
<p>The OS does not operate properly.</p>	<p>Is [Type] in [Primary Slave] set to [Auto] in the IDE setting?</p> <p>SEE → ■ <i>Primary Master / Primary Slave (page4-5)</i></p>
	<p>Did you connect a new hard disk drive or commercial USB memory which does not require boot-up?</p> <p>SEE → 4.2.5 <i>Boot (page4-28)</i></p>
	<p>If this symptom occurs, setting [Power on Delay] to [Enabled] may solve the problem.</p> <p>SEE → <i>Power On Delay (page4-8)</i></p>

Problem	Countermeasure and reference page
<p>The OS does not operate properly.</p>	<p>When some of the following conditions occur simultaneously, there is a high probability that the PS-A has failed while writing to files, resulting in this error.</p> <ul style="list-style-type: none"> • The same file is frequently accessed (opened, read, written, etc.). • The amount of implemented memory is small and cache memory is insufficient. • The file is highly fragmented. • The I/O load to the disk is high. • Delay writing fails. <p>Try performing maintenance on the hard disk. If the problem continues, replace the hard disk.</p>
<p>“Delayed Write Failed” occurs frequently.</p>	<p>When some of the following conditions occur simultaneously, there is a high probability that the PS-A has failed while writing to files, resulting in this error.</p> <ul style="list-style-type: none"> • The same file is frequently accessed (opened, read, written, etc.). • The amount of implemented memory is small and cache memory is insufficient. • The file is highly fragmented. • The I/O load to the disk is high. • Delay writing fails. <p>Try performing maintenance on the hard disk. If the problem continues, replace the hard disk.</p>
<p>I want to use a LAN to recover the OS from standby or sleep mode.</p>	<p>Set the PS-A as follows:</p> <ol style="list-style-type: none"> 1. Select [Control Panel] from the Start menu. 2. Double-click [System]. (With Windows XP, it is in the [Performance and Maintenance] category.) 3. Click [Device Manager] on the [Hardware] tab. 4. Double-click [Intel PRO/**] in [Network adapters]. 5. On the [Power Management] tab, check [Wake on Magic Packet].
<p>I did not shut down or reboot the unit, but the “CMOS CHECK SUM ERROR” occurred.</p>	<p>The clock data back-up battery may be exhausted. Replace the battery. Note that when the battery is removed, the BIOS settings will be lost so you need to set up the BIOS again after replacing the battery.</p> <p>The battery may be exhausted more quickly under the following conditions.</p> <ul style="list-style-type: none"> • The temperature of the surrounding environment frequently changes from low to high. • The connected expansion board consumes the CMOS battery quickly. <p>SEE → 7 Maintenance (page7-1)</p>
<p>The connected peripheral device does not work.</p>	<p>Is the power cable connected properly?</p> <p>SEE → 3 Hardware Installation (page3-1)</p>
	<p>Is the peripheral device connected properly?</p> <p>→Refer to the manual for the connected device.</p>
	<p>Does the device require driver setup?</p> <p>→Refer to the manual for the connected device and set the driver properly.</p>
	<p>Did you start the PS-A unit with a USB device connected?</p> <p>→If the PS-A unit is started while USB memory or another USB device is connected, the following phenomenon may occur depending on the device.</p> <ul style="list-style-type: none"> • It takes about 1 minute before the OS starts up. • If the USB device is not recognized, set [Power on Delay] to [Enable]. This may solve the problem.

Problem	Countermeasure and reference page
The touch panel does not respond.	You need to install the touch panel driver when you use the PS-A with no pre-installed OS. SEE → 5.3.1 Driver (page5-6)
The touch panel does not respond even after the touch panel driver is installed.	If the touch panel does not respond even after the touch panel driver is installed, possible causes are: <ul style="list-style-type: none"> • The connected external device (including a keyboard and a mouse) may not be compatible with the PS-A. → Disconnect the external device and check the touch operation. • A touch panel driver (or drivers) other than the driver downloaded from the Pro-face support site “Otasuke Pro!” is installed in the PS-A. → Uninstall such a driver(s) and make sure that only the driver downloaded from “Otasuke Pro!” is installed in the PS-A. Then check the touch operation. • The touch panel driver setting has been changed. → If the touch panel driver setting has been changed, touch actions may not work properly. Please contact your local PS-A distributor.
The touch position recognized in the touch panel deviates from the actual touch.	Have you calibrated the touch panel? SEE → 5.3.1 Driver (page5-6)
The touch position recognized in the touch panel still deviates from the actual touch even after calibration.	If the touch position still deviates after calibration, possible causes are: <ul style="list-style-type: none"> • There are flaws or unevenness on the surface of the PS-A. → If the bracket securing the PS-A is tightened too much, flaws or unevenness may result. Release the PS-A from the bracket and check whether the problem continues. • The touch panel calibration was not finished properly. → Uninstall the touch panel driver once, and then install the latest driver. The latest driver can be downloaded from the Pro-face support site “Otasuke Pro!”. • The hardware in the touch recognition section is faulty. → Use the PS-A that operates properly and check whether the same problem occurs. If the problem occurs only with a specific unit, contact your local PS-A distributor for repair or replacement.
I want to know what the LED indicator indicates.	SEE → ◆ LED Indicator (page6-5)
A Touch Panel Self-Test Error occurred.	The touch panel is faulty. Please contact your local PS-A distributor.

8.2 Recovery Procedure

8.2.1 PS-A with no Pre-installed OS

Refer to the instruction manual for the installed OS and recover the OS.

When the OS is recovered, set up the software.

SEE → ■ *Special PS-A Software Setup (page5-2)*

8.2.2 PS-A with Pre-installed OS (Windows® 2000/Windows® XP)

IMPORTANT

- After performing hard disk recovery, the PS-A unit's hard disk is returned to its factory shipped condition.
- For recovery, a commercially-available USB keyboard is required. In addition, a commercially available USB CD-ROM drive is also required when no DVD drive is pre-installed in the PS-A unit.
- Do not connect the external storage unit such as USB device and CF Card while the recovery.

Use the following steps used to recover the Windows® XP Multi-Language Pre-installed Hard Disk.

- (1) Turn on the power of PS-A and immediately press the [F2] key to enter the BIOS setup screen. Insert the Recovery media into the drive.
- (2) Under [Boot priority order] on the [Boot] menu, use the [+] or [-] key to move [USB CDROM] to the top.

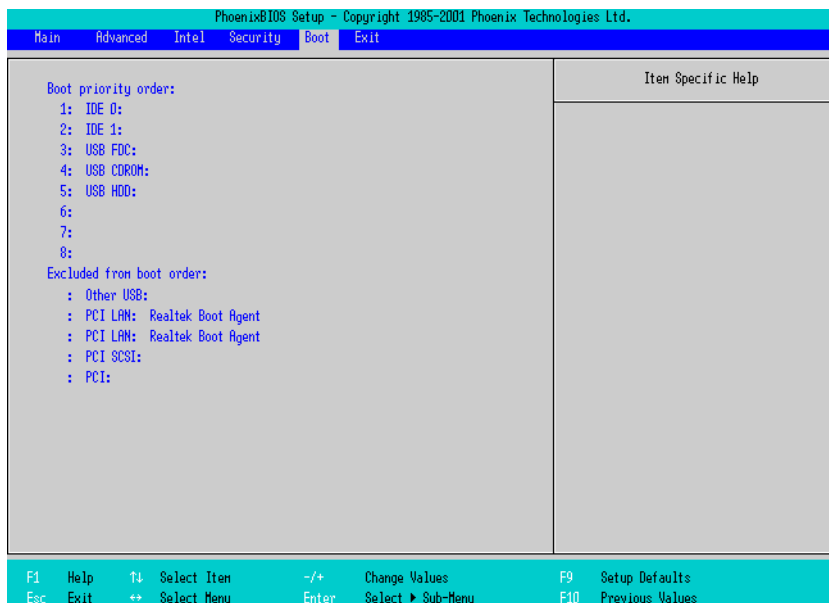

- (3) Press the [F10] key and select [Yes] for [Save configuration changes and exit now?] to save the settings and restart the PS-A unit.
- (4) After the PS-A unit restarts, the Symantec Ghost™ will automatically start.
- (5) After the Symantec Ghost™ starts, the [Question] dialog box will appear.
“Partition sizes correct?”

NOTE

- Touch operation is disabled on the Symantec Ghost™ screen. Operate the screen with the USB keyboard or USB mouse.

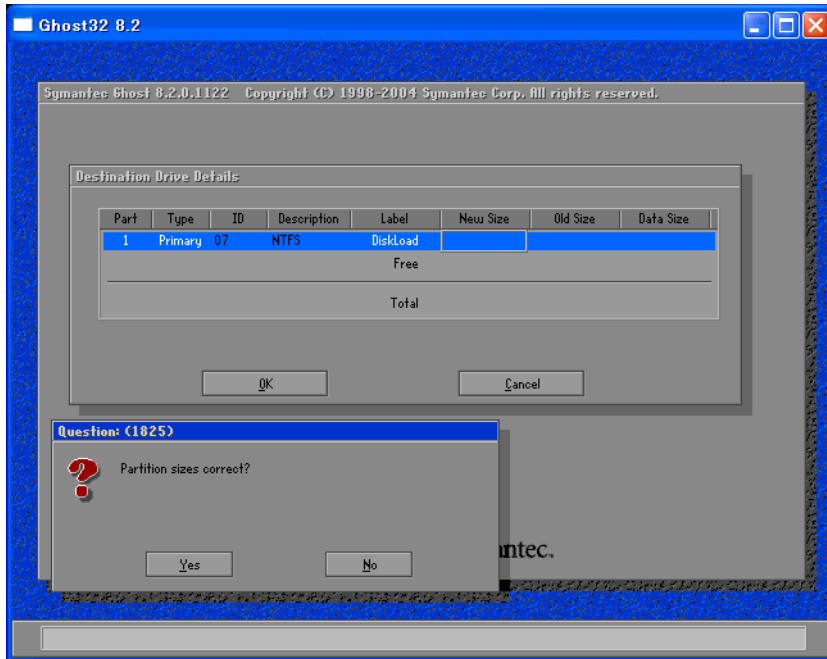

- (6) The volume displayed in New Size will be recovered. After confirming it, press the [Yes] button. To change it, press the [No] button and go to the [Destination Drive Details] dialog box. In the [Destination Drive Details] dialog box, change the size of the New Size and press the [OK] button.

- (7) The [Question] dialog box will appear. Press the [Yes] button. It will be reconfirmed that the data of the hard disk is all reset to the original values at the time of delivery.

“Proceed with disk restore? Destination drive will be permanently overwritten.”

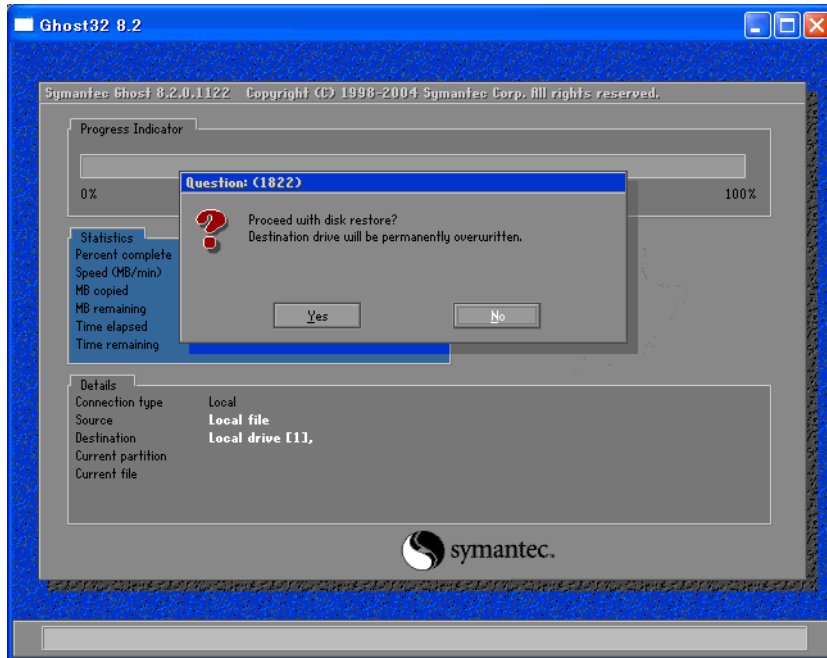

- (8) The hard disk recovery program will start. After the recovery operation finishes, the Symantec Ghost™ also will finish. When the message “Please turn off computer” displayed, turn off the power of PS-A.
- (9) Turn on the power of PS-A again and immediately press the [F2] key to enter the BIOS setup screen.
- (10) Press the [F9] key and select [Yes] for [Load default configuration now?] to set the BIOS setting to the factory setting. Press the [F10] key to save the setting and restart the PS-A unit.
- (11) After the unit restarts, set up your OS.

SEE → ■ *Setting Up the OS (page5-2)*

IMPORTANT

- If BIOS does not recognize the boot drive or if there is a hardware malfunction, the drive cannot be recovered with Symantec Ghost™. In such cases, Pro-face recommends that you contact your local PS-A distributor for instructions about drive recovery or replacement.
- Pro-face does not guarantee the preservation of any data stored on the HDD unit if the HDD unit has an accident, malfunctions or is damaged in any way. Therefore, the regular backing up of important HDD unit data to either floppy disks, or other type of suitable magnetic media is strongly recommended.

A | Appendices

1. I/O Map
2. Memory Map
3. Interrupt Map
4. License Agreement

This section describes the hardware configuration including the I/O map, memory map and interrupt map.

1 I/O Map

Address	AT System Device	System Device
0000H-001FH	DMA controller (8237)	
0020H-003FH	Interrupt controller (8259A)	
0040H-005FH	System timer (8254)	
0060H-006FH	Keyboard controller	
0070H-007FH	Real time clock, NMI mask	
0080H-009FH	DMA page register	
00A0H-00BFH	Interrupt controller 2 (8259A)	
00C0H-00DFH	DMA controller 2 (8237)	
00F0H-00FFH	Numeric data processor	
01F0H-01FFH	Hard disk (IDE)	
0290H-0297H	Reserved	System monitor
02F8H-02FFH	Reserved	
03B0H-03BBH	Video controller (VGA)	
03C0H-03DFH	Video controller (VGA)	
03F8H-03FFH	Serial port 1 (COM1): General use	

NOTE

- The resources of the PCI BUS board that is installed by the user are automatically assigned to the free resource by the Plug and Play feature.

2 Memory Map

SMRAM	MAXMEM
FrameBuffer	MAXMEM-1MB
Expanded Memory	MAXMEM-9MB* ¹
System BIOS	1MB
Expanded ROM Area	F000:0000
PXE BIOS, VGA BIOS	D000:0000
Video RAM	C000:0000
Conventional Memory	A000:0000
	0000:0000

*1 The capacity allocated by “IGD-Memory Size” of the “Video (Intel IGD) Control Sub-Menu” screen of the BIOS setting is 1MB.

3 Interrupt Map

NOTE • The interrupts and DMA channel will change depending on the PnP features of PCI available.

■ Hardware Interrupt List

	Description
NMI	Parity Error or I/O Channel Check
IRQ 0	Timer (in the Chipset)
1	Keyboard
2	Cascade from Controller 2
3	Reserved
4	Serial Port 1 (COM2): General Use Port
5	Available for users *
6	Reserved
7	Available for users *
8	Real Time Clock
9	ACPI
10	Available for users *
11	Available for users *
12	Available for users *
13	Numeric Data Processor
14	Hard Disk (IDE)
15	Hard Disk (IDE)

IMPORTANT • The “*” mark indicates that, depending on the customer’s settings, the following devices are automatically allocated as Plug and Play devices.

- Display Controller
- SMBus Controller
- Multimedia Device
- Network Controller
- USB Controller

■ DMA Channel List

	Description	
DMA 0		For 8-bit transmission
1		
2		
3		
4	Cascade to controller 1	For 8-bit transmission
5		
6		
7		

4 License Agreement

■ DMC Corporation Mouse Emulation Software (TSC-1310D/DD) Software License Agreement

Before unsealing and using this product, please read the following license agreement carefully:

This license agreement regarding the following software product (hereinafter called “product”) is concluded between you the individual or entity licensing the product (hereinafter called (“licensee”) and DMC Co., Ltd. (hereinafter called “DMC”). With unsealing, installing, copying or using the product, the licensee is regarded to agree this contract and the contract is in force. Please confirm and understand this agreement fully in advance. If you do not agree this contract, do not unseal, install, copy or use the software product at all. In such a case, please return the product at an unused state to the place you the licensee purchased it. Your payment will be returned to the licensee.

1. Copyright

The copyright of the software product belongs to Touch-Base, Ltd.

2. License

For the programs included in this product and the documents related to it, DMC grants untransferable nonexclusive license to licensee, which permits use of the product under the following conditions:

- (1) When a licensee does not purchase the license which permits the licensee to use a licensed product and its copy(s) and/or the license which permits use of the product on multiple computers, the licensee is granted the right to use the product on a single computer.
- (2) The licensee can create one copy of the product for archival purposes. For the other purposes, copying the whole or part of the product is strictly prohibited whichever medium you use.
- (3) The licensee shall display the copyright notice and other necessary information which is the same as that for the product on every copy of the product.
- (4) The intangible property right of the product and its copy(s) belong to DMC or the DMC supplier.

3. Term of use

This contract shall maintain its validity from conclusion of the contract to the cancellation by DMC or the licensee.

4. Termination of the right of use

- (1) The licensee can at any time terminate the right to use the product by expunging or destroying the product and all the copied contents.
- (2) When a licensee contravenes these license contents, DMC can notify the licensee of termination of the right to use the product. In this case, the licensee shall return the product or all the copied contents to DMC within one month.

5. Limited Warranty

- (1) DMC guarantees that 90 days after the licensee purchased the product, neither material nor manufacturing flaws shall be found at the medium where the product has been recorded or stored. If any errors related to the material or manufacturing is recognized when the product is installed, we shall replace the medium used to install the product on the condition that we are notified of it within the guaranteed period.
- (2) DMC shall grant the right to use the product at a state it has been supplied without explicit or implicit guarantee except for replacement of the medium containing product described in the above clause. Further, we do not guarantee that the product is suitable as useful for the licensee's specific purpose of use and that execution of the product is neither interrupted nor an error is found at its execution.
- (3) The responsibility attributable to DMC based on this agreement is limited to replacement of the medium containing the product, and DMC shall not assume any responsibility for the explicit or implicit guarantee including the other legal warranty against a defect and a liability for reparation given from a third party to the licensee regarding the licensee's profit loss caused by the product, damage arising from a special circumstance and the damage against data or intangible property right.

6. Licensee's obligation

The licensee shall recognize that the product shall possess the confidential information or property information including the intangible property right protected by the Copyright Act and shall not take the following actions:

- (1) Use and copying of the product against the terms of the license and disassembling, reverse engineering, and modifying the product.
- (2) Transfer, leasing and sublicensing of the product to the third party.
- (3) Deletion and/or change of display of the intangible property right including the copyright displayed on the medium containing the product.

7. Restrictions on Export

When the product is subjected to the regulation of the Foreign Exchange and Foreign Trade Control Act and the laws and regulations accompanying it and the Export, the licensee shall observe the corresponding laws and regulations and rules.



<http://www.dmccoltd.com>

Hironokougyoudanchi, Hirono-machi, Futaba-gun, Fukushima

979-0401, Japan

Phone: +81-240-27-4030 Fax: +81-240-27-4025

■ IN-fINITY soft Keyclick32

Digital Electronics Corporation shall be in no case liable for any loss or damages to you or any third party whatsoever arising from any faulty performance of IN-fINITY soft, nor shall be responsible to correct such error of the software program in question.

