

Connecting to the Handy Type GP

- 1 System Structure
- 2 GP2000H Optional Items
- 3 Preparing RS-232C/RS-422 Cables for the GP2000H Series unit
- 4 Cable Diagrams

- This manual explains how to connect the target machine with devices from other manufacturers. For information about how to use the Pro-Designer software, please refer to the Pro-Designer Online Help.
- The types of target machines that are compatible with Pro-Designer depends on the Pro-Designer version. For information about target machine compatibility, please refer to the Pro-Designer Online Help.

1 System Structure

The following describes the peripheral devices that connect to the GP2000H Series unit.
For cable diagrams, refer to Section 4 - *Cable Diagrams*.

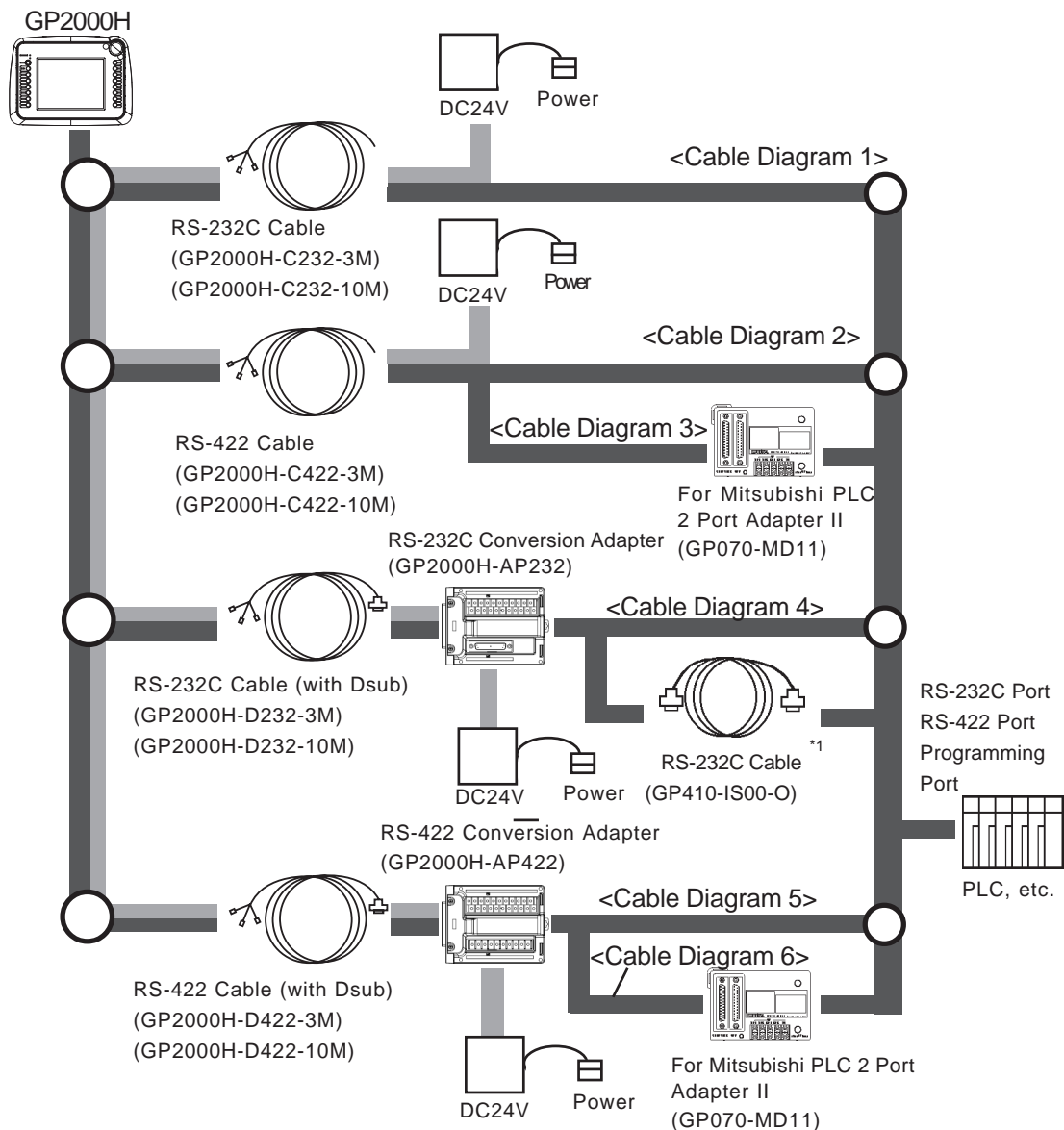

MEMO • In the above system design diagram, the  line indicates power supply routes. Be sure to supply electricity through conversion adapters or cables.

*1 This cable may not be able to be connected to some PLCs. Be sure to check compatibility before connecting.

2 GP2000H Optional Items

The following optional cables and cable conversion adapters below can be used to connect a PLC to a GP2000H Series unit.

ITEM	DESCRIPTION
GP2000H Series Special Purpose RS-232C Cable GP2000H-C232-3M (3m) GP2000H-C232-10M (10m)	Included in this cable are the power line to the GP2000H; the communications lines (RS-232C) used with various Host (PLC)s; the GP2000H's DOUT signal line, as well as other lines. This cable has no PLC connector attached so the user can set up the cable's PLC side wires to suit any type or PLC connector.
GP2000H Series Special Purpose RS-422 Cable GP2000H-C422-3M (3m) GP2000H-C422-10M (10m)	Included in this cable are the power line to the GP2000H; the communications lines (RS-422) used with various Host (PLC)s; the GP2000H's DOUT signal line, as well as other lines. This cable has no PLC connector attached so the user can set up the cable's PLC side wires to suit any type or PLC connector.
GP2000H Series Special Purpose RS-232C Dsub Cable GP2000H-D232-3M (3m) GP2000H-D232-10M (10m)	Included in this cable are the power line to the GP2000H; the communications lines (RS-232C) used with various Host (PLC)s; the GP2000H's DOUT signal line, as well as other lines. This cable's PLC side connector is a standard Dsub37 pin type.
GP2000H Series Special Purpose RS-422 Dsub Cable GP2000H-D422-3M (3m) GP2000H-D422-10M (10m)	Included in this cable are the power line to the GP2000H; the communications lines (RS-422) used with various Host (PLC)s; the GP2000H's DOUT signal line, as well as other lines. This cable's PLC side connector is a standard Dsub37 pin type.
GP2000H Series RS-232C Conversion Adapter GP2000H-AP232	This adapter is used to convert the wiring from the GP2000H to either a Dsub37 or standard a terminal block connector. Pro-face's 232C cable (GP410-IS00-O) can be connected to the Dsub25 connector, and Pro-face's GP2000H-D232-3M/10M cable can be used to connect the adapter to the GP2000H unit.
GP2000H Series RS-422 Conversion Adapter GP2000H-AP422	This adapter is used to convert the wiring from the GP2000H to either a Dsub25 or standard a terminal block connector. Pro-face's GP2000H-D422-3M/10M cable can be used to connect the adapter to the GP2000H unit.

3 Preparing RS-232C/RS-422 cables for the GP2000H Series unit

The optional RS-232C cable for GP2000H Series unit (GP2000H-C232-3M/10M) and the optional RS-422 cable for GP2000H Series unit (GP2000H-C422-3M/10M) will require some preparation before they can be used. Pro-face's Device/PLC Driver Manual includes connection diagram(s) of the wiring connections used between the GP and the Device/PLC. However, the pin number assigned to each connector pin on the Handy Type GP's interface will differ from that of other GP Series units. Therefore, be sure to use the Connector Pin Comparison Tables below when creating a cable used between the GP2000H and the Device/PLC.

Connector Pin Comparison Tables for GP2000H Series and other GP Series units

GP2000H Series RS-232C Cable (GP-2000H-C232-3M/10M)

I/F	GP2000H Pin No.	Signal Name	Wire Color	Non-GP2000H Series Pin No.
DC24V I/F	3	FG	Shield	1
Serial I/F	1	RS	Red	4
	2	SD	Blue	2
	3	CS	Brown	5
	4	RD	Orange	3
	5	CD	Purple	8
	6	ER	Gray	20
	8	SG	White	7

MEMO

- Be sure to connect this unit's #8 (SG) to the other unit's SG Terminal.

GP2000H Series RS-422 Cable (GP2000H-C422-3M/10M)

I/F	GP2000H Pin No.	Signal Name	Wire Color	Non-GP2000H Series Pin No.
DC24V I/F	3	FG	Shield	1
Serial I/F	8	SG	Gray	7
	13	RDA	White	10
	14	RDB	Black	16
	15	SDA	Yellow	11
	16	SDB	Green	15
	17	CSA	Red	21
	18	CSB	Blue	18
	19	ERA	Red	22
	20	ERB	Orange	19

MEMO

- Be sure to connect this unit's #8 (SG) to the other unit's SG Terminal.
- The following pairs of pin #'s must be connected to each other
 - ...#17 (CSA) <-> #19 (ERA)
 - ...#18 (CSB) <-> #20 (ERB)
- When turning ON the switch inside the GP2000H rear-face's cable cover, a termination resistance of 100Ω is added between #13 (RDA) and #14 (RDB).
- When the GP is set as a Memory Link type and the cable type is RS-422, a 4-wire system must be used.

Conversion Example

The following is an example of converting the pin assignments for other GP series to those on the Handy Type GP. The following example connects a GP2000H with a Mitsubishi MELSEC-A Series PLC.

MELSEC-A Link (SIO) Driver Cable Diagram 1(RS-232C)

Pin assignments for all GP Series other than the Handy Type GP.

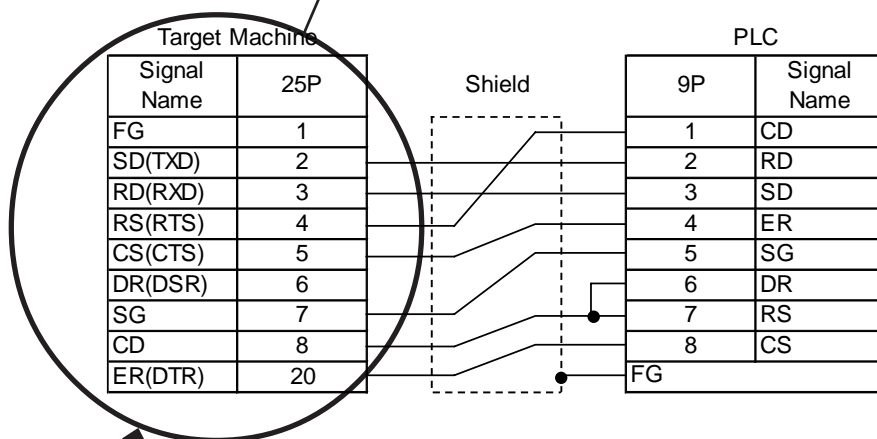

When using GP2000H optional cable (GP2000H-C232-3M/10M), Pin assignments for the GP2000H converted from those of other GP series

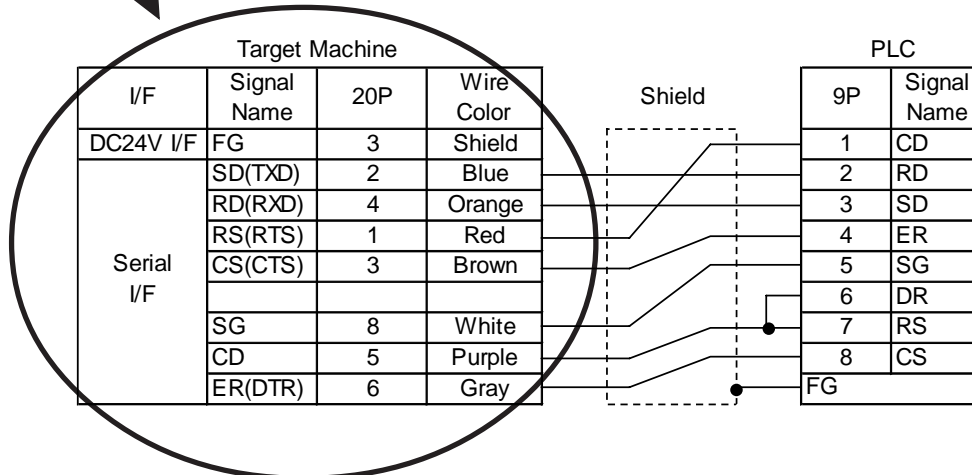

- If any wires in the above table's "Wire Color" column are not used, be sure those wires do not touch other signal wires or the connector case.
- Be sure to connect the cable's outer shield to the FG wire (field ground).

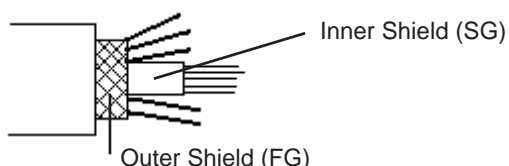

- Be sure to connect the inner shield to the external device's signal ground, in the same way as the Pin #8's SG connection.

4 Cable Diagrams

The connection diagram of wiring connections used between the equipment as described in Section 1 - *System Structure* is shown below.



CAUTIONS

- ❗ Be sure to connect this cable while the GP2000H's power is turned OFF, otherwise an electrical shock may occur.
 - ❗ When live lines are either connected or disconnected, if a difference in potential is created between the GP2000H and the connected device(s), the driver IC may be damaged. Therefore, be sure to connect this cable while the GP2000H's power is turned OFF.
 - ❗ Since the GP2000H interface signal wires and the GP power supply wires are contained inside a single cable, power supply noise may occur. Therefore, be sure to take appropriate precautions to prevent the connected device(s) from being interrupted by noise. (i.e. install a noise filter, etc.).
-
- When connecting the communication cable, be sure to connect the SG.
 - The AWG22 is used for DC24V and external output wires.

MEMO

- Apart from the optional cable/adaptor, it is necessary to connect the power supply cord to the GP2000H Series unit.

Cable Diagram 1 RS-232C Cable

When connecting GP2000H to PLC with RS-232C Cable.

Target Machine	Cable/Adaptor	Remarks
GP2000H	RS-232 Cable for GP2000H Series unit (Pro-face: GP2000H-C232-3M(3m) GP2000H-C232-10M(10m))	Cable length: 15m max.

I/F	Signal Name	Pin No.	Wire Color	25P
DC24V I/F	FG	3	Shield	1 ^{*1}
Serial I/F	SD(TXD)	2	Blue	2
	RD(RXD)	4	Orange	3
	RS(RTS)	1	Red	4
	CS(CTS)	3	Brown	5
	SG	8	White	7
	CD	5	Purple	8
	ER(DTR)	6	Gray	20

Device/PLC 

*1 Connect the cable's outer shield to Pin 1.

*2 Refer to the cable diagrams as well as Section 3 - *Preparing RS-232C/RS-422 Cables for the GP2000H Series Unit.*

MEMO

- The customer will need to perform this cable's PLC connector wiring. The wires used for this cable are AWG 28 (dia.=0.3mm/area=0.08mm²). Using a solder cap tape connector is recommended.
- Be sure the wires do not touch other signal wires or connector case when they are not used.

Cable Diagram 2 RS-422 Cable

When connecting GP2000H to PLC with RS-422 Cable.

Target Machine	Cable/Adaptor	Remarks
GP2000H	RS-422 Cable for GP2000H Series (Pro-face: GP2000H-C422-3M(3m) GP2000H-C422-10M(10m))	Cable length: 500m max.

I/F	Signal Name	Pin No.	Wire Color	25P
DC24V I/F	FG	3	Shield	1 ^{*1}
	SG	8	Grey	7
Serial I/F	RDA	13	White	10
	SDA	15	Yellow	11
	SDB	16	Green	15
	RDB	14	Black	16
	CSB	18	Blue	18
	ERB	20	Orange	19
	CSA	17	Red	21
	ERA	19	Brown	22

Device/PLC

*1 Connect the cable's outer shield to Pin 1.

*2 Refer to the cable diagrams as well as Section 3 - *Preparing RS-232C/RS-422 Cables for the GP2000H Series Unit.*

MEMO

- The customer will need to perform this cable's PLC connector wiring. The wires used for this cable are AWG 28 (dia.=0.3mm/area=0.08mm²). Using a solder cap tape connector is recommended.
- Be sure the wires do not touch other signal wires or connector case when they are not used.

Cable Diagram 3 RS-422 Cable and 2 Port Adapter II

When connecting GP2000H to Mitsubishi PLC 2 Port Adapter II (GP070-MD11) with RS-422 Cable.

Target Machine	Cable/Adaptor	Remarks
GP2000H	RS-422 Cable for GP2000H (Pro-face: GP2000H-C422-3M(3m) GP2000H-C422-10M(10m)) and 2 Port Adaptor II (Pro-face: GP070-MD11)	Cable length: 500m max.

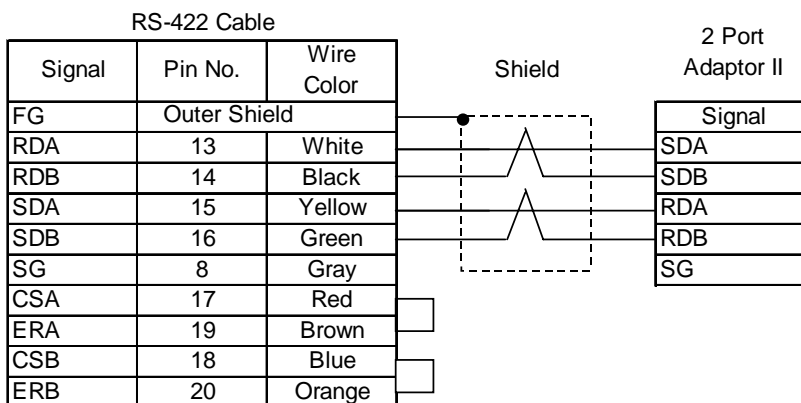
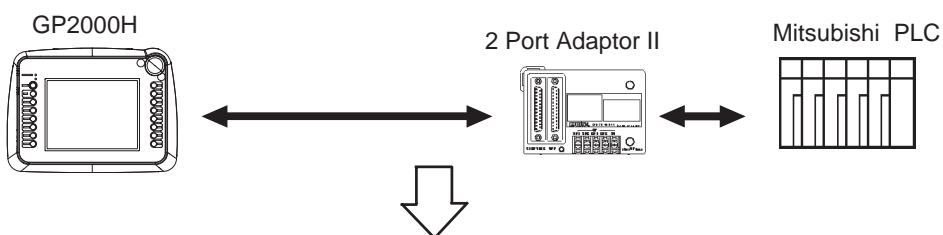
**MEMO**

- Be sure the wires do not touch other signal wires or connector case when they are not used.

Cable Diagram 4 RS-232C Cable (with Dsub) and RS-232C Conversion Adapter

When connecting GP2000H to PLC via RS-232C Conversion Adapter (GP2000H-AP232) with RS-232C Cable (with Dsub).

Target Machine	Cable/Adaptor	Remarks
GP2000H	RS-232C Cable (with Dsub) for GP2000H (Pro-face: GP2000H-D232C-3M(3m) GP2000H-D232C-10M(10m)) and RS-232C Conversion Adaptor (Pro-face: GP2000H-AP232)	Cable length: 15m max.

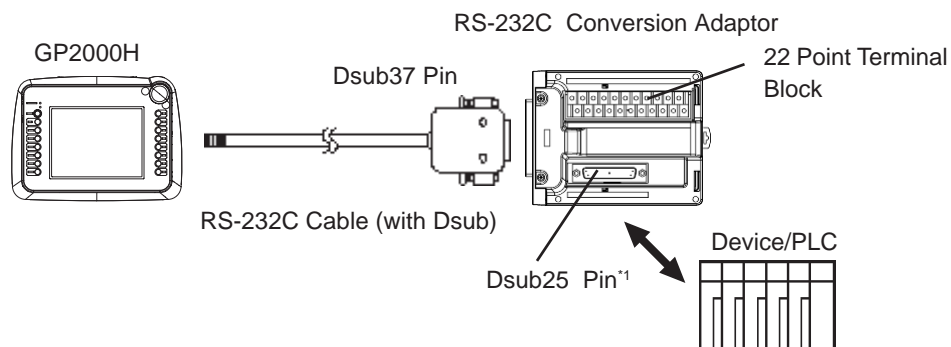

*1 Refer to the following pin numbers as well as the cable diagrams.

25P	Signal Name
1	FG
2	SD(TXD)
3	RD(RXD)
4	RS(RTS)
5	CS(CTS)
7	SG
8	CD
14	+5V(Output)
20	ER(DTR)

22 Point Terminal Block	Signal Name (Drawing Name)
1	DOUT0.C (DO0)
2	RESERVE
3	DOUT1.C (DO1)
4	RESERVE
5	OP.C (OP)
6	OP.GND (OPG)
7	BUZZ OUT (BZ)
8	DOUT GND (DOG)
9	EMG0A (EM0A)
10	EMG0B (EM0B)
11	EMG1A (EM1A)
12	EMG1B (EM1B)
13	EMG2A (EM2A)
14	EMG2B (EM2B)
15	ENB0A (EN0A)
16	ENB0B (EN0B)
17	ENB1A (EN1A)
18	ENB1B (EN1B)
19	Power Input +24V (+24V)
20	Power Input 0V (0V)
21	NC (NC)
22	FG (FG)

Cable Diagram 5 RS-422 Cable (with Dsub) and RS-422 Conversion Adapter

When connecting GP2000H to PLC via RS-422 Conversion Adapter (GP2000H-AP232) with RS-422 Cable (with Dsub).

Target Machine	Cable/Adaptor	Remarks
GP2000H	RS-422 Cable (with Dsub) for GP2000H (Pro-face: GP2000H-D422-3M(3m) GP2000H-D422-10M(10m)) and RS-422 Conversion Adapter (Pro-face: GP2000H-AP422)	Cable length: 500m max.

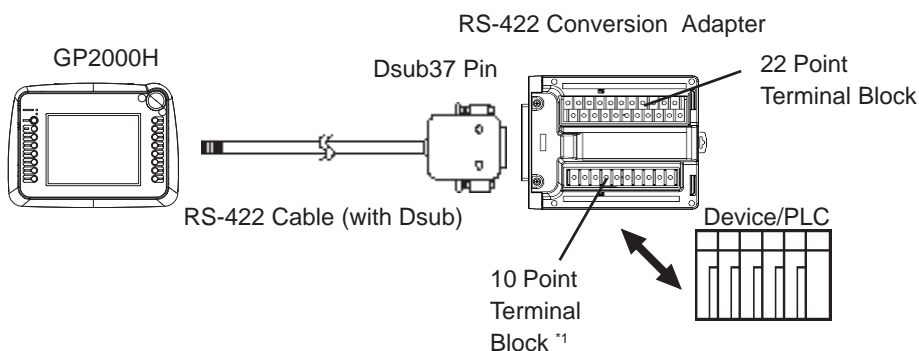

*1 Refer to the following pin numbers as well as the cable diagrams.

10 Point Terminal Block	Signal Name
1	FG
2	SG
3	SDB
4	SDA
5	RDB
5	RDA
7	CSA
8	ERA
9	CSB
10	ERB

Pin # 7 and #8; #9 and #10 are respectively shorted with connecting board.

When it is not necessary to short on your PLC, remove the connecting board.

22 Point Terminal Block	Signal Name (Drawing Name)
1	DOUT0.C (DO0)
2	RESERVE
3	DOUT1.C (DO1)
4	RESERVE
5	OP.C (OP)
6	OP.GND (OPG)
7	BUZZ OUT (BZ)
8	DOUT GND (DOG)
9	EMG0A (EM0A)
10	EMG0B (EM0B)
11	EMG1A (EM1A)
12	EMG1B (EM1B)
13	EMG2A (EM2A)
14	EMG2B (EM2B)
15	ENB0A (EN0A)
16	ENB0B (EN0B)
17	ENB1A (EN1A)
18	ENB1B (EN1B)
19	Power Input +24V (+24V)
20	Power Input 0V (0V)
21	NC (NC)
22	FG (FG)

Cable Diagram 6 RS-422 Cable (with Dsub), RS-422 Conversion Adaptor and 2 Port Adaptor II

When connecting GP2000H to PLC via RS-422 Conversion Adaptor (GP2000H-AP422) and 2 Port Adaptor II with RS-422 Cable (with Dsub).

Target Machine	Cable/Adaptor	Remarks
GP2000H	RS-422 Cable (with Dsub) for GP2000H (Pro-face: GP2000H-D422-3M(3m) GP2000H-D422-10M(10m)) and RS-422 Conversion Adapter (Pro-face: GP2000H-AP422) and 2 Port Adapter II (Pro-face: GP070-MD11)	Cable length: 500m max.

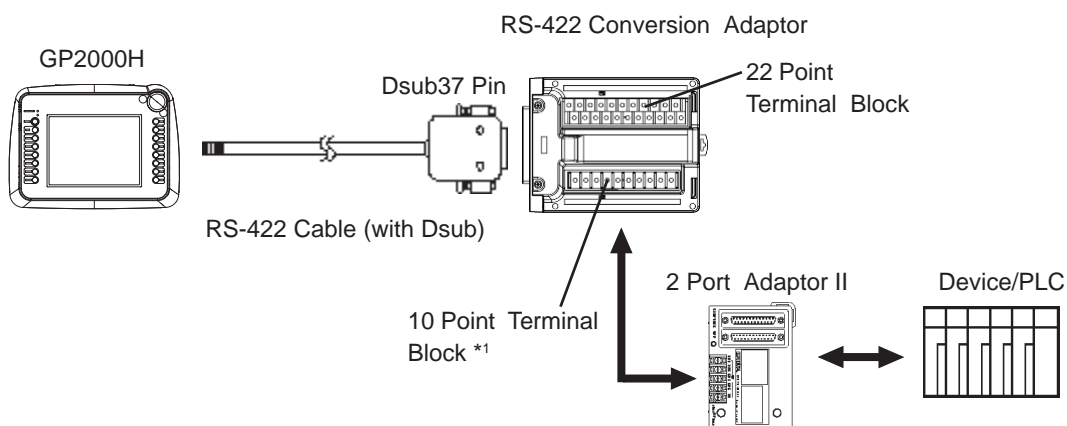

*1 Refer to the following pin numbers as well as the cable diagrams.

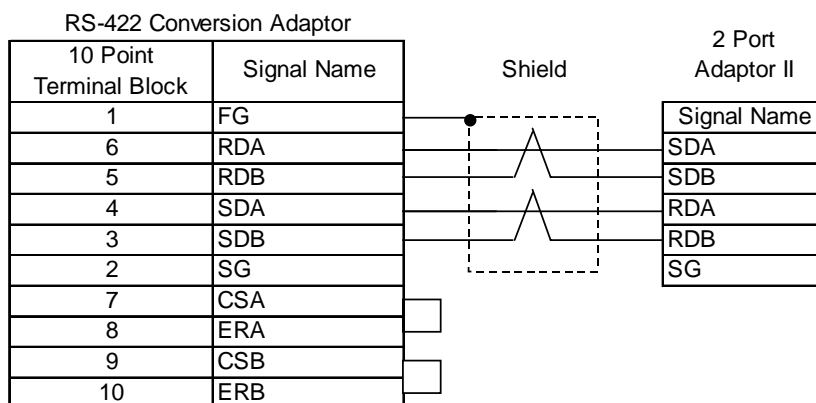

Pins CSA and ERA; CSB and ERB are respectively shorted with connecting board