

PREFACE

Thank you for purchasing Pro-face ladder logic programming software “Pro-Control Editor Ver. 3.0” for use with Pro-face GLC series of graphical logic controllers.

To ensure the safe and correct use of this product, be sure to read all related materials carefully and keep them nearby so that you can refer to them whenever required.

NOTE

- (1) The copyrights to all programs and manuals included in the “Pro-Control Editor Ver. 3.0” (hereinafter referred to as “this product”) are reserved by Digital Electronics Corporation. Digital grants the use of this product to its users as described in the “Software Operating Conditions section”. Any actions violating the abovementioned conditions are prohibited by both Japanese and foreign regulations.
- (2) The contents of this manual have been thoroughly inspected. However, if you should find any errors or omissions in this manual, please contact your local sales representative.
- (3) Regardless of the above clause, Digital Electronics Corporation shall not be held responsible for any damages or third party claims resulting from the use of this product.
- (4) Differences may exist between the descriptions found in this manual and the actual functioning of this software. Therefore, the latest information on this software is provided in the form of data files (i.e. Readme.txt files, etc.) and/or separate documents. Please refer to these sources as well as this manual prior to use.
- (5) Even though the information contained in and displayed by this product may be related to intangible or intellectual properties of Digital Electronics Corporation or third parties, Digital Electronics Corporation shall not warrant or grant the use of said properties to any users or other third parties.

©Copyright 2000 Digital Electronics Corporation. All rights reserved.
Digital Electronics Corporation November 2000

For the rights to trademarks and trade names, see “TRADEMARK RIGHTS”.

TRADEMARK RIGHTS

The company names and product names used in this manual are the trade names, trademarks (including registered trademarks), and service marks of their respective companies.

This product omits individual descriptions of each of these rights.

Trademark / Tradename	Right Holder
Microsoft, MS, MS-DOS, Windows, Windows 95, Windows 98, Windows NT, Windows Explorer	Microsoft, U.S.
Intel, Pentium	Intel, U.S.
Flex Network	Digital Electronics Corporation
Pro-face	(in Japan and other countries)
IBM compatible	IBM, U.S.
Adobe, Acrobat	Adobe Systems Corporation

The following terms used in this manual differ from the above mentioned formal trade names and trademarks.

Term used in this manual	Formal Tradename or Trademark
Windows 95	Microsoft ® Windows® 95 Operating System
Windows 98	Microsoft ® Windows® 98 Operating System
MS-DOS	Microsoft® MS-DOS® Operating System
Windows NT	Microsoft® Windows NT® Operating System
Acrobat Reader	Adobe® Acrobat® Reader

APPLICABLE PRODUCTS

The products used with the Pro-Control Editor Ver. 3.0 software are as follows:

■ Applicable Units

GLC100 Series, GLC300 Series, GLC2400 Series units

■ Applicable Software

Screen Creation Software - GP-PRO/PBIII for Windows Ver. 5.0 or later

Communication Software - Pro-Server with Pro-Studio for Windows Ver. 3.0 or later

HOW TO USE THIS MANUAL

This manual is “Pro-Control Editor Ver 3.0 User Manual” which describes how to use the “Pro-Control Editor Ver 3.0” software (hereafter referred to as “this product”).

The Pro-Control Editor Ver. 3.0 CD-ROM includes the following PDF manuals.

- Pro-Control Ver. 3.0 User Manual (This manual)
- Pro-Control Editor Ver. 3.0 Operation Manual

To read these PDF data, Acrobat Reader 4.0 is needed. A PDF manual allows you to display manual data quickly and easily on your PC via “Bookmarks”. It can also be distributed via e-mail etc. as a data file due to its small size.

The following table provides a list of the manuals related to this product. Please refer to these manuals when you have questions.

Data Included in this product	Pro-Control User Manual (this manual)		Describes the software settings used for GLC series units.
	Pro-Control Editor Operation Manual		Describes the procedures for installation and operation of this product. Includes a tutorial lesson, and an extensive warning/error message list.
	Online Help		This product’s Help data contains: 1. Pro-Control Help (Describes the features, functioning, and operation of this product) 2. DIO Driver Help (Describes DIO driver operation) 3. Flex Network Driver Help (Describes Flex Network Driver operation)
Related Data	GLC series User Manual		GLC series units’ hardware users manual.
	GP-PRO/PBIII Manuals *1	Operation Manual	Describes the procedures for the installation, operation, and functioning of GP-PRO/PBIII.
		Tag Reference Manual	Includes detailed descriptions on the “T ags” used to specify functions used on the GP unit.
		Parts List	Describes both the pre-made Parts included with GP-PRO/PBIII and the symbols that can be called up.
		PLC Connection Manual	Describes how to make connections between GP series units and other manufacture’s PLCs.
2-Way Communicator Software *2	Operation Manual	Describes the procedures for the operation, and functioning of 2-Way Communicator Software.	

In addition to these manuals, information on additional/updated functions may be provided as data files (i.e, ‘readme. txt’ attached to a floppy disk, or a CD-ROM). Please also refer to them.

*1: The GP screen creation software for this product is GP-PRO/PB III for Windows Ver. 5.0 or higher. The Manual for GP-PRO/PB III for Windows Ver. 5.0 (except for the installation guide) is contained in the CD-ROM in PDF format.

*2: The 2 Way Communicator software for this product is Pro-Server with Pro-Studio for Windows Ver. 3.0 or higher. The Manual for Pro-Server with Pro-Studio for Windows Ver. 3.0 is contained in the CD-ROM in PDF format.

TABLE OF CONTENTS

Preface	1
Trademark Rights	2
Applicable Products	2
How to Use this Manual	3
Table of Contents	4
Manual Symbols and Terminology	6
Product Usage Precautions	7

CHAPTER 1 - Overview

1.1 Prior to Operating the GLC	1-1
1.2 System Design	1-3
1.2.1 Usage Patterns	1-3
1.2.2 Usage Options	1-4

CHAPTER 2 - GLC Overview

2.1 Operating the GLC	2-1
2.1.1 GLC Scan Overview	2-1
2.1.2 Controller Feature Overview	2-2
2.1.3 RUN Mode	2-4

CHAPTER 3 - Variables

3.1 Variable Types	3-1
3.2 Accessing Variables	3-2
3.3 Variable Names	3-4

CHAPTER 4 - System Variables

4.1 System Variable List	4-1
--------------------------------	-----

CHAPTER 5 - Instructions

5.1 Instruction List	5-1
----------------------------	-----

CHAPTER 6 - LS Area Refresh

6.1 Overview	6-1
6.2 LS Area Refresh Settings	6-2
6.2.1 System Data Area	6-3
6.2.2 Special Relays	6-5
6.3 GLC and PLC Data Sharing	6-6
6.3.1 Read Area	6-7
6.3.2 LS Area Refresh Cautions	6-7

CHAPTER 7 - I/O Drivers

7.1 Overview	7-1
7.2 DIO Driver	7-2
7.2.1 DIO Unit Self-Diagnosis	7-2
7.2.2 I/O Monitor (I/O connection check)	7-4
7.2.3 Troubleshooting	7-5
7.3 Flex Network I/F Driver	7-9
7.3.1 Flex Network I/F Unit Self-Diagnosis	7-9
7.3.2 I/O Monitor (I/O connection check)	7-12
7.3.3 Troubleshooting	7-17

CHAPTER 8 - Error Messages

8.1 Error Message List	8-1
8.2 Error Codes	8-3
8.3 Program Errors	8-4

Index

MANUAL SYMBOLS AND TERMINOLOGY





This manual uses the following symbols and terminology.

If you have any questions about the contents of this manual, please contact your local GLC distributor.

Also, if you have any question about your personal computer, Windows 95, Windows 98, or Windows NT, please contact your local distributor or manufacturer.



■ Safety Symbols and Terms

This manual uses the following symbols and terms for important information related to the correct and safe operation of this product.

Symbol	Description
 <i>Warning</i>	Incorrect operation resulting from negligence of this instruction may cause death or serious injury.
 <i>Caution</i>	Incorrect operation resulting from negligence of this instruction may cause injury or damage to equipment.
 <i>Important</i>	Failure to observe this instruction may cause abnormal operation of equipment or data loss.
 <i>Careful!</i>	Instructions / procedures that must be performed to ensure correct product use.
 STOP	Actions / procedures that should <u>not</u> be performed.

■ General Information Symbols and Terms

This manual uses the following symbols and terms for general information.

Symbol	Description
 <i>Note:</i>	Provides hints on correct use, or supplementary information.
 <i>Reference</i>	Indicates related (manual name, page number) information.
*1, *2, (etc.)	Indicates footnotes.
Pro-Control Editor	Software used for editing, transferring, and monitoring of a GLC ladder logic program.
Controller	Indicates the GLC unit's built-in control features.
GP-PRO/PBIII (screen creation software)	The screen creation software GP-PRO/PBIII for Windows Ver. 5.0 or later.
GLC	Indicates the "GLC series" of graphic logic controller manufactured by the Digital Electronics Corporation.
PLC	Abbreviation for Programmable Logic Controller

PRODUCT USAGE PRECAUTIONS



WARNING

Do not use the GLC unit for control in situations where a life-threatening accident or major machine damage could occur.

■ Disk Media Usage Precautions

To prevent disk (i.e. CD-ROM or floppy) damage or data loss, please observe the following instructions:



- **Be sure to remove the disk media from its disk drive prior to turning the PC ON or OFF.**



- Do not remove the disk media from its drive while the drive operation lamp is lit.
- Do not touch the disk media's (CD-ROM or floppy disk) recording surface.
- Do not place the disk(s) where they may be exposed to extremely high or low temperatures, high humidity, or dust.
- Do not place a floppy disk near stereo speakers, TVs or any device producing a magnetic field.

MEMO

1

Overview

1.1

Prior to Operating the GLC

The following steps are required prior to using the GLC.

- 1 Preparation** Before using the GLC, check that all required hardware is present and read all specification, wiring, and installation information.
Reference *GLC Users Manual (sold separately)*
- 2 Design** Design the GLC screen images, tag layout and logic program.
- 3 Screen Editor Software Installation** Install the screen editor software in your personal computer.
Reference *GP-PRO/PBIII for Windows Operation Manual (included in screen editor package)*
- 4 Logic Program Development Software Installation** Install the logic program development software in the personal computer where the screen editor software has already been installed.
Reference *Pro-Control Editor Operation Manual (included in the Pro-Control Editor package)*
- 5 Logic Program Creation** Use the logic program development software to create the logic program, and set up the operation modes.
Reference *Pro-Control Editor Operation Manual (included in the Pro-Control Editor package)*
- 6 Symbol Import/Screen Creation/Active Image Setup/Screen Data Transfer** Register (import) symbols and create screens with screen editor software. Transfer the data to the GLC unit.
Reference *GP-PRO/PBIII for Windows Operation Manual (included in the screen editor package)*
- 7 Logic Program Transfer/Monitor** Use the logic program development software to transfer the program to the GLC unit. The transferred logic program can be checked via the logic program development software's monitor feature.
Reference *Pro-Control Editor Operation Manual (included in the Pro-Control Editor package)*
- 8 Initial Settings** Enter the GLC's initial settings, according to the type of usage desired.
Reference *GLC Users Manual (sold separately)*
GP-PRO/PB III for Windows PLC Connection Manual (included in the screen editor package)
- 9 Operation** Connect the GLC and expansion unit, as well as peripheral devices required, and start operation.
Reference *GP-PRO/PBIII for Windows PLC Connection Manual (included in the screen editor package) and each expansion unit's User's Manual.*

1.2 System Design

1.2.1 Usage Patterns

The GLC can be used in either of the following systems.

■ Stand-Alone System

The expansion unit can be attached to the GLC to perform I/O control.

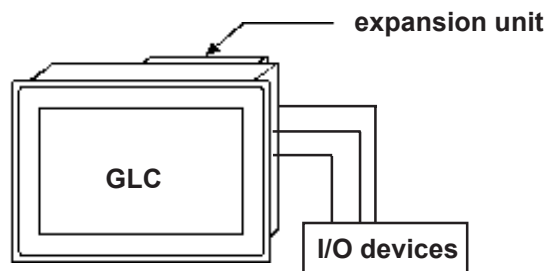

■ Direct PLC Connection

Connecting the GLC to a PLC allows you to send data between the GLC and a PLC. At the same time, the Expansion unit can also be attached to the GLC to perform I/O control.

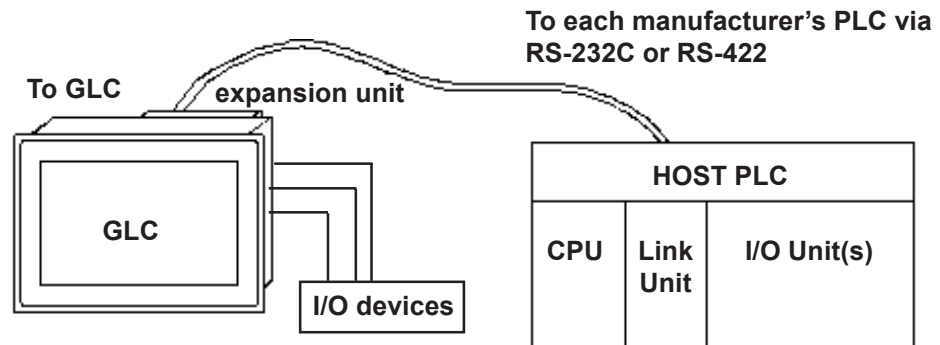

1.2.2 Usage Options

The following peripheral devices can be used being connected with the GLC 100 and GLC 300 units:

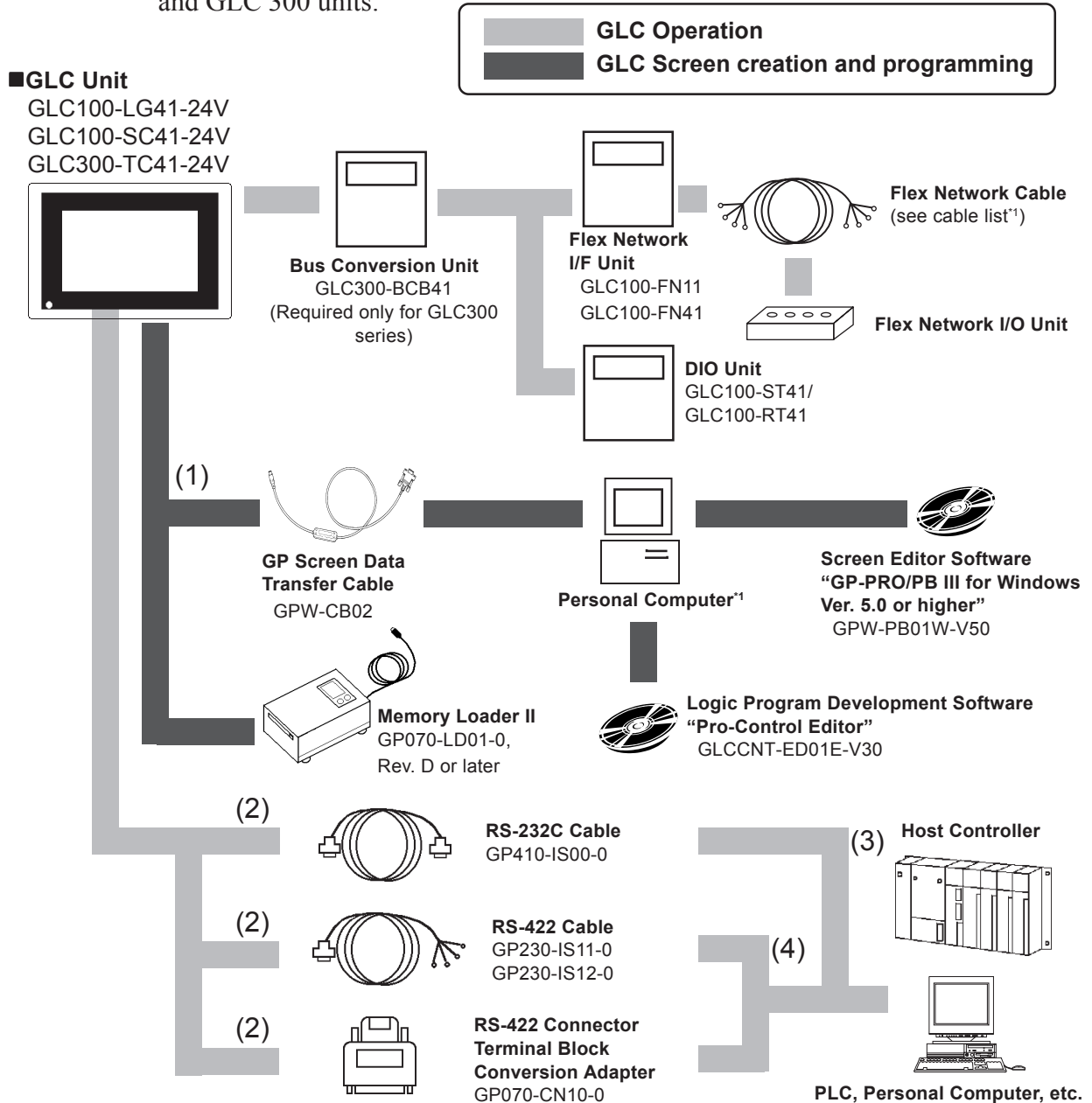

GLC Interfaces

- (1) Tool Connector
- (2) Serial Interface

PLC/Personal Computer Interfaces

- (3) RS-232C Port
- (4) RS-422 Port

*1 Personal computer running English Windows95/98/NT4.0

*2 GPW-CB-SET can also be used.

*3 Flex Network Cables

Model	Vender	Unit
FN-CABLE2050-31-MS	Digital Electronics Corporation	50 m
FN-CABLE2200-31-MS	Digital Electronics Corporation	200 m

The following peripheral devices can be used being connected with the GLC2400 unit.

■ Operation Environment

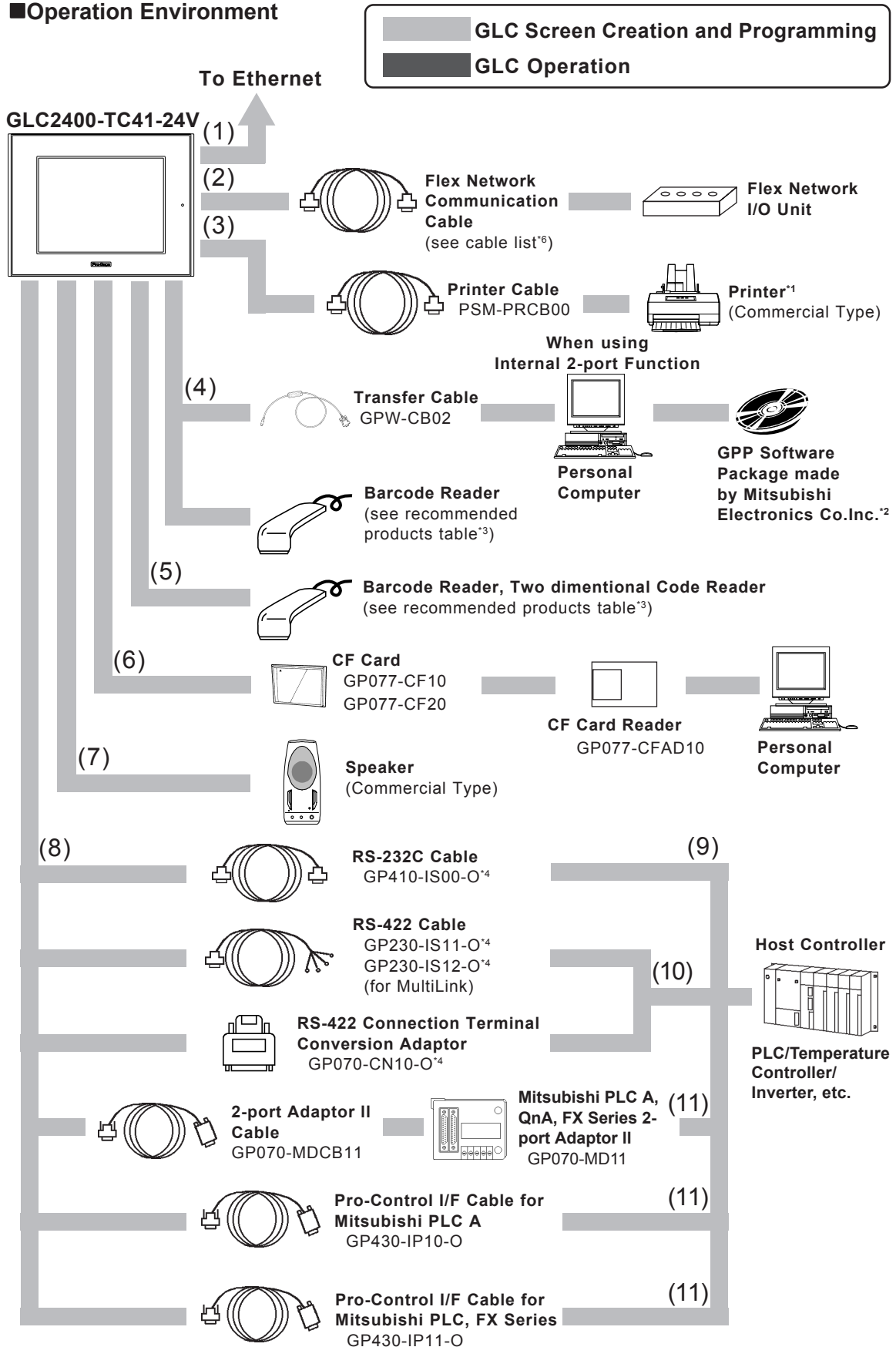

■ Screen Creation and Programming Environment

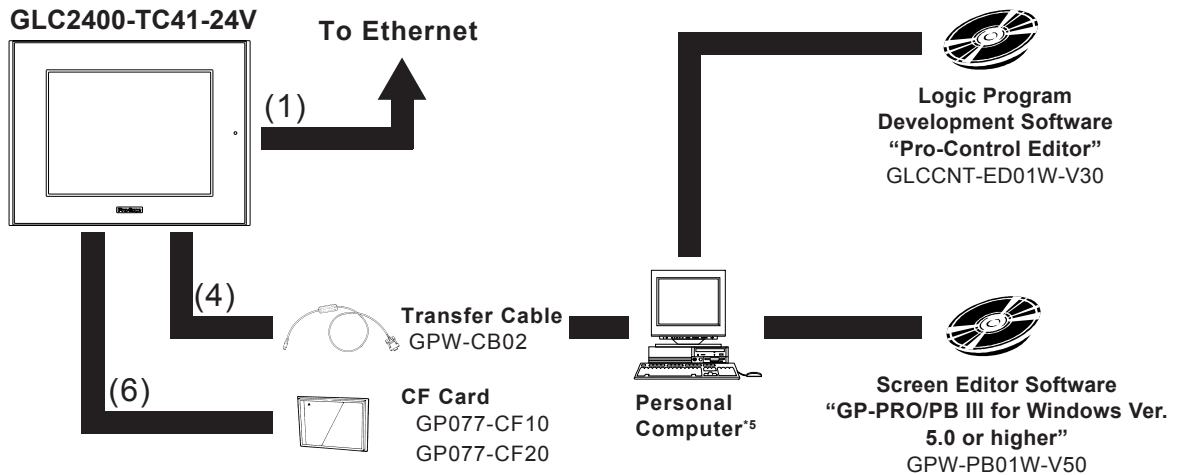

GLC Interfaces

- (1) Ethernet Interface
- (2) Flex Network Interface
- (3) Printer Interface
- (4) Tool Connector
- (5) Expansion Serial Interface
- (6) CF Card Interface

- (7) Sound Interface
 - (8) Serial Interface
- PLC Interfaces**
- (9) RS-232C Port
 - (10) RS-422 Port
 - (11) Programming Console Port

*1 This system can be used with NEC PC-PR201/PL command compatible machines, EPSON ESC/P24-J84 (C) command compatible machines, and HP Laser Jet PCL 4 command compatible machines. It cannot be used with special-purpose printers for Windows. Printers with the above commands (or the equivalent) can be used. In some cases, it is possible to use a printer which has drivers for both Windows and DOS. For details, please inquire with the printer manufacturer or your sales representative.

*2 For compatible PLC and compatible software,

Reference GR-PRO/PB III for Windows PLC Connection Manual (Included in GP screen creation software)

*3 Recommended bar code reader

Made by Imex Co., Ltd.	Made by Optoelectronics Co., Ltd.		Made by Imex Co., Ltd.	
Pen-Type	Scanning Width	Touch Scanner type	Scanning Width	Touch Scanner Type
BR-331 PC2	60 mm	OPT-1105-RSK 98 set	65 mm	T CD-5510M
	80 mm	OPT-5105-RSK 98 set	82 mm	T CD-5510L
	100 mm	OPL-6735-RSK 98 set	105 mm	T CD-5510W

*4 Certain PLCs can not be connected using this cable.

Reference GR-PRO/PB III for Windows PLC Connection Manual (Included in GP screen editor software)

*5 PC operating with Windows 95/98/NT 4.0/2000

*6 Equipment

<Connectors>

	Model	Manufacturer
I/F Connector	MCV1,5/6-GF-3,81	Phoenix Contact
Data Transfer Cable Connector	MC1,5/6-STF-3,81	Phoenix Contact

<Cables>

Model	Vendor	Length
FN-CABLE2050-31-MS	Digital Electronics Corporation	50 m
FN-CABLE2200-31-MS	Digital Electronics Corporation	200 m

MEMO

2

GLC Overview

2.1

Operating the GLC

The GLC contains both screen display and I/O control features. These features and their respective modes are described below.

GLC Features

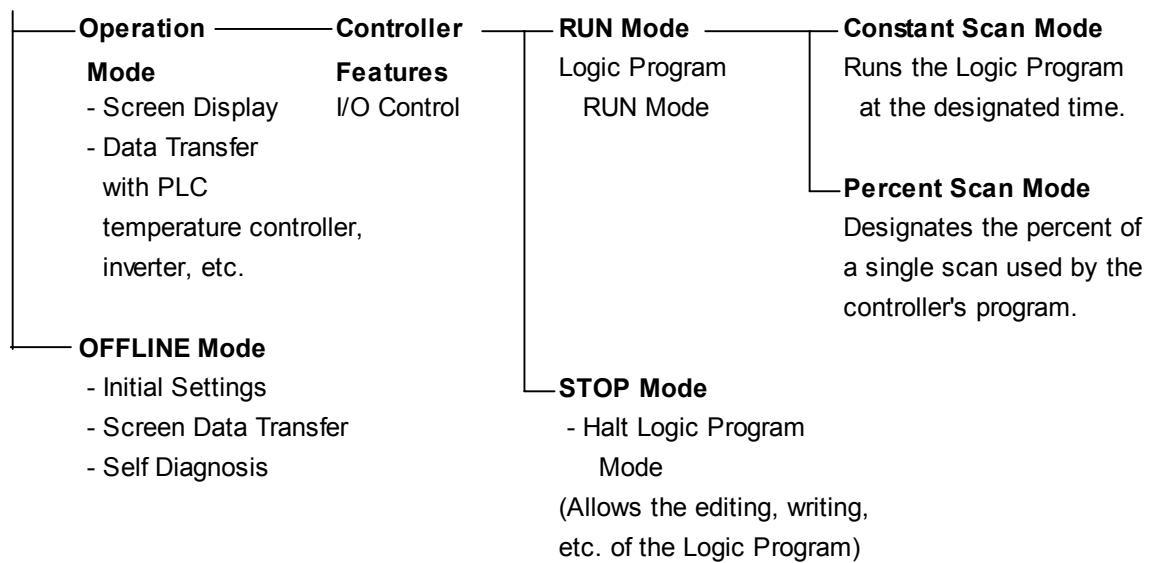

When OFFLINE mode is entered, the Controller will stop. Re-entering RUN mode will reset the Controller feature.

2.1.1 GLC Scan Overview

GLC Scan time includes ladder circuit execution time, screen processing time, SIO communication time and touch panel processing time as follows.

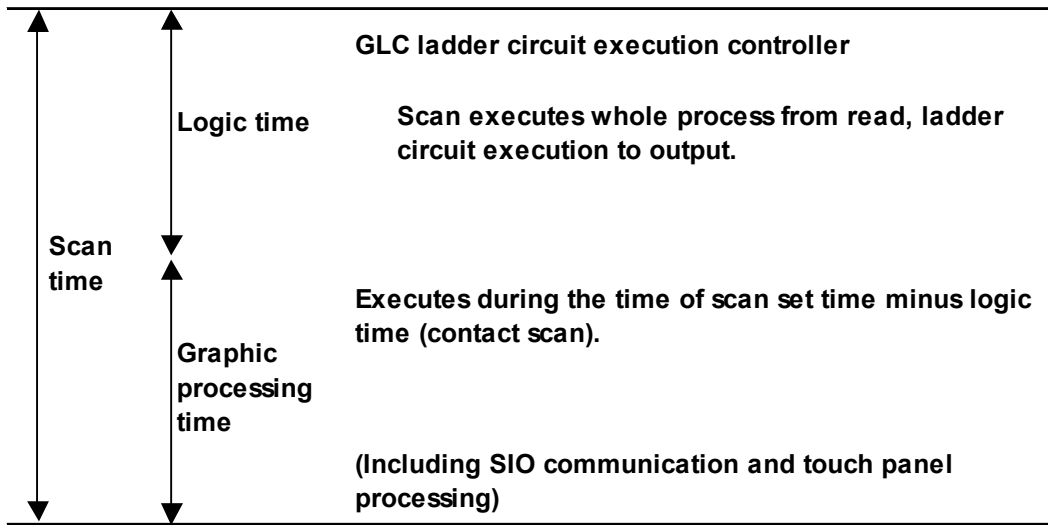

Reference 2.1.3 RUM Mode

2.1.2 Controller Feature Overview

The Controller feature functions as follows. The facing page provides detailed descriptions of each step.

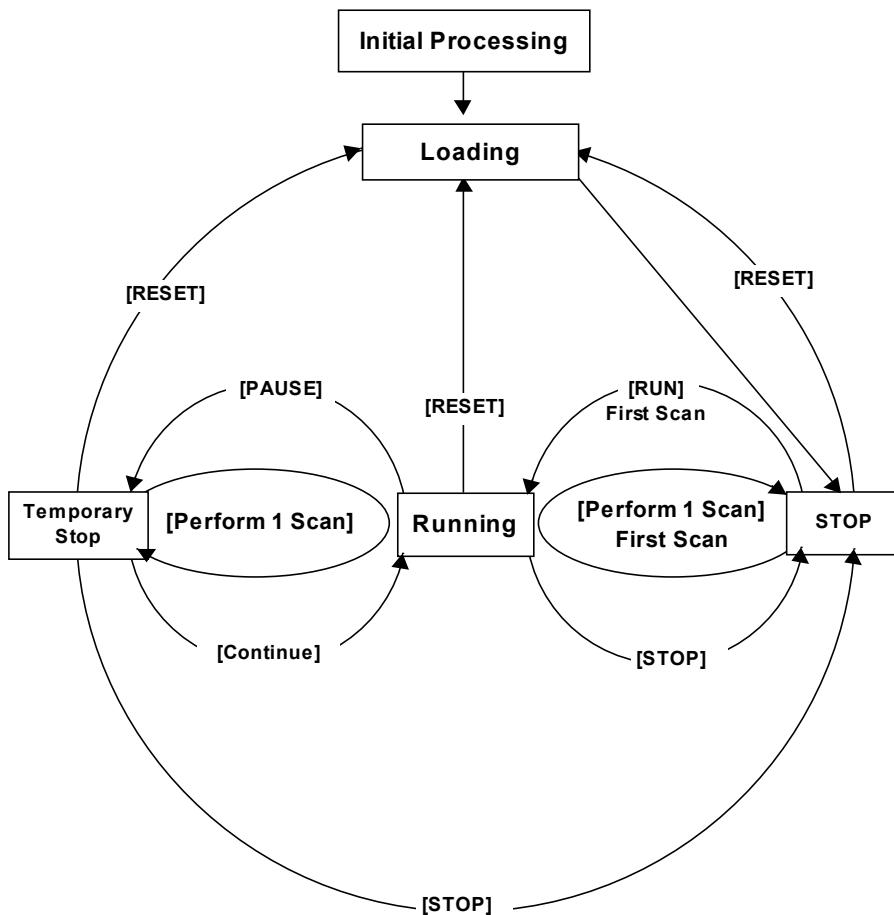

■ Initial Processing

This is the original state of the engine use to perform the Logic Program. Once initialization is finished, the Controller enters the “Loading” state.

■ Loading

Here, the actual reading in of the Logic Program is performed. After a check is performed to determine whether the Logic Program is successfully loaded or not, error processing is performed if an error has occurred. If Loading is successful, the program enters the [STOP] state. If the [Power ON Operation Mode] is set to [START], the [RUN] instruction is automatically performed.

■ STOP

In this condition the Controller is waiting to receive another instruction. Once the [RESET], [Perform 1 Scan], [Continue], or [PAUSE] instructions are received, the Controller changes to that condition.

The [RESET] instruction will change the program to the [Loading] condition.

The [RUN] instruction will change the program to the [Running] condition.

The [Perform 1 Scan] instruction will perform the program once.

■ First Scan

Executes the I/O Read, performs any Logic Program that is higher the START level, and executes the I/O write.

■ Running

This is the Logic Program performance engine’s continuous performance condition. Executes the I/O Read, performs the Logic Program, executes the I/O write, and updates the System Variables. (#AvglogicTime, #AvgscanTime, etc.)

The [RESET] instruction will change the program to the [Loading] condition.

The [STOP] instruction will change the program to the [STOP] condition.

The [PAUSE] instruction will change the program to the [Temporary Stop] condition.

■ Temporary Stop

The logic program execution engine is temporarily stopped in this state. To avoid an I/O watchdog timeout, the system executes an I/O read and I/O write. However, the logic program is not executed, so the output state does not change. When a command is received, the system switches to the appropriate state.

The [RESET] instruction will change the program to the [Loading] condition.

The [Perform 1 Scan] instruction will perform the program once.

The [STOP] instruction will change the program to the [STOP] condition.

The [Continue] instruction will change the program to the [Running] condition.

2.1.3 RUN Mode

RUN Mode uses the following steps.

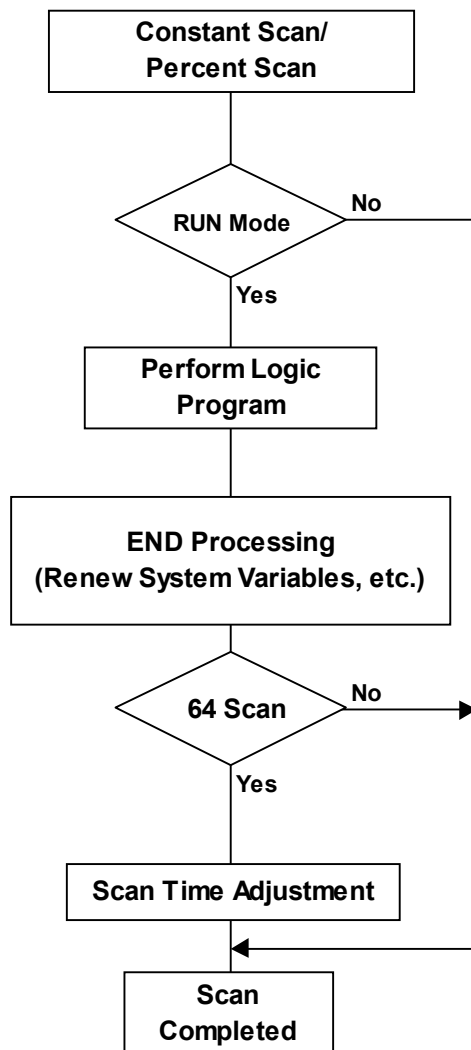

- Standard Scan Mode
- Pause Mode
- Scan Time Adjustment

This adjustment is performed every 64 scans. The various types of adjustments are described below for Constant Scan Time, and Percent Scan Time.

◆ **Constant Scan Time Mode**

$$\text{GLC scan time} = (\#AvgLogicTime \times 100) / 50$$

◆ **Percent Scan Time Mode**

$$\text{GLC scan time} = (\#AvgLogicTime \times 100) / \#PercentAlloc$$

For information about #AvgLogicTime, or #PercentAlloc,

Reference Chapter 4 - System Variables



**The GLC's ScanTime includes the following error:
GLC 100 - approx. 0.2%, GLC 300 - 0.2%, GLC2400 - 0.2%**

■ **Constant Scan Time Mode**

Constantly executing the program during the scan time set.

<Priority is set for processing speed>

Here, the screen is used mainly for data display and less for operation, with control (logic program) being the priority.

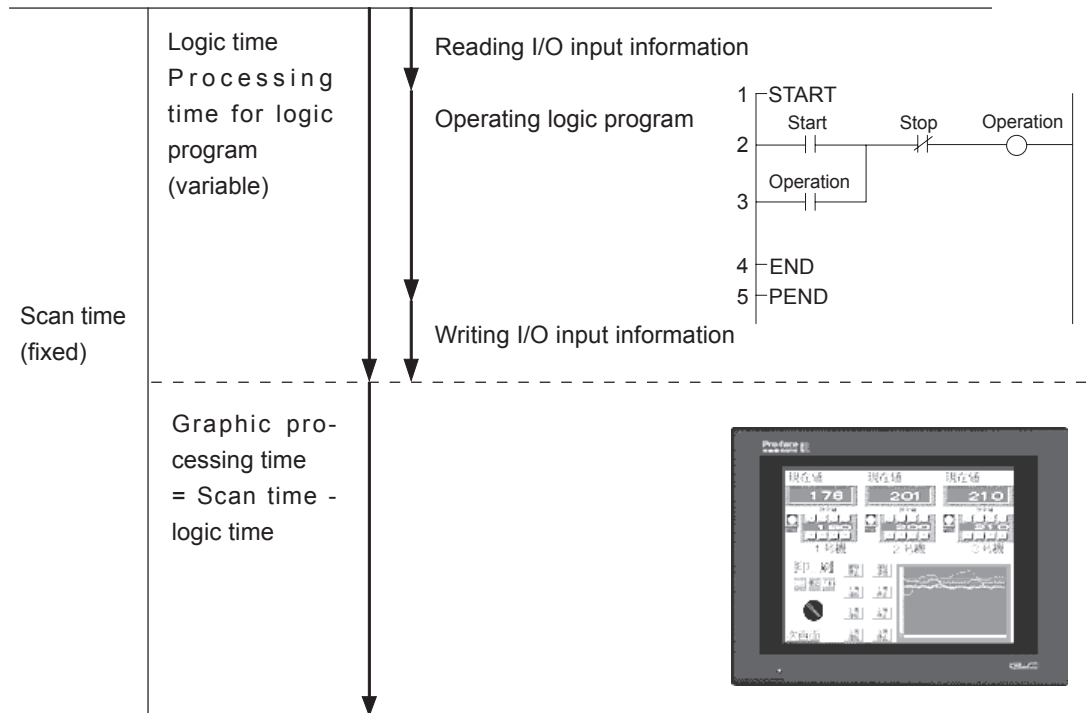

Graphic processing time = Setting time for constant scan time mode (ms) - logic time (variable)

e.g.) If constant scan time is set to 100 ms and logic executing time is 30 ms

$$\begin{aligned} \text{Graphic processing time} &= 100 \text{ ms} - 30 \text{ ms} \\ &= 70 \text{ ms} \end{aligned}$$

* The longer the logic time, the shorter the Graphic processing time to spare

Note: Though GLC display response will be slower, logic program will execute constantly.



If the logic execution time exceeds 50% of the setting time (example: 100 ms), the system adjusts automatically so that the logic time becomes 50% of the scan time.

■Percent Scan Time Mode

This mode varies the scan time according to the percentage set by the logic time

<Priority is set for screen display>

Set the priority to the operation speed and switching speed of the display and varies the scan time according to the control time (logic program).

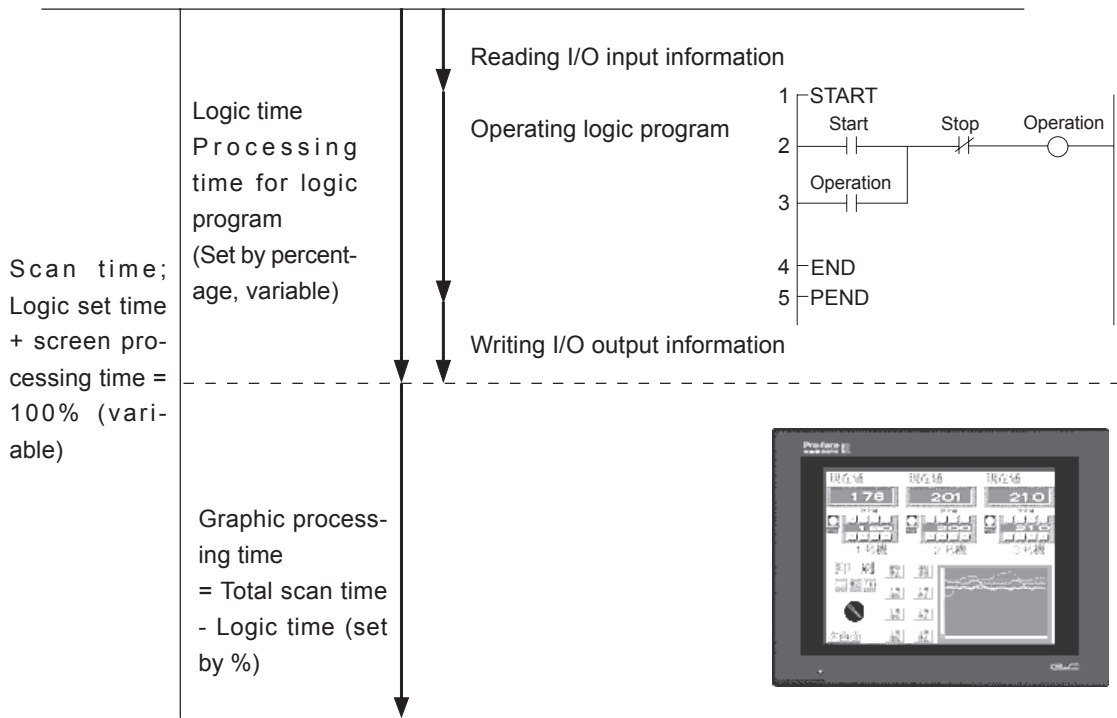

$$\text{Scan time} = \text{Logic time} / \text{Percent scan set time (\%)}$$

e.g.) If percent scan time is set to 10% and logic executing time is 20 ms

$$\begin{aligned} \text{Scan time} &= (20 \div 10) \times 100 \\ &= 200 \text{ ms} \end{aligned}$$

$$\begin{aligned} \text{Graphic processing time} &= 200 \text{ ms} - 20 \text{ ms} \\ &= 180 \text{ ms} \end{aligned}$$

* When logic time increases, display processing time increases, resulting in increased scan time.

Note: The longer the logic time, the longer the time allocated to display processing; therefore the display is updated more quickly on the GLC, but the logic program processing cycle slows.



- **There is no change in the processing time for one instruction in the logic program.**
- **The scan setting (%) cannot be set over 50%.**

3

Variables

This chapter explains the different types of variables used by the Pro-Control software.

3.1

Variable Types

The Pro-Control software uses three different types of variables - Discrete, Integer and Real.

Within each of these variable types, arrays can also be defined and used. Theoretically, the maximum size (number of elements) of an array can be up to 65535, however, the actual number of elements that can be used by any application will be limited by the size of the GLC's variable storage area. In the GLC the amount of memory available for variables is limited to 32Kbytes. Please be sure to design your system so the number of variables used in memory does not exceed the GLC's limit. Please refer to the following table for information about the amount of memory used by each variable.

Variable Type	Memory Used (unit:byte)
Discrete	12
Discrete Array	20+12 (for each element)
Integer	8
Integer Array	20+8 (for each element)
Real	16
Real Array	20+16 (for each element)
Timer	48
Counter	80



It is possible to set for each variable whether data is retained or cleared when data is reloaded (during GLC shutdown or startup), or when STOP mode changes to RUN mode.

■ Discrete Variables

These variables are used to define a discrete condition, i.e. ON or OFF, using a single bit and the values "0" or "1".

■ Integer Variables

These variables use 32 bits to define integer values from -2147483648 to 214783647.

■ Real Variables

These variables use 64 bits to define floating decimal point values from +/-2.25e-308 to +/-1.79e+308, and "0".

3.2 Accessing Variables

This section explains how to access variable array elements, bits, bytes and words. This feature is only available via the Pro-Control program, not GP-PRO/PBIII for Windows.

■ Array Variables

An array is a method of declaring and handling multiple elements with a single variable name.

For example, imagine the drawers of desk or cabinet.

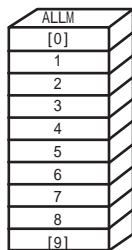

The array variable ALLM[10] means that cabinet ALLM has 10 drawers prepared, numbered from [0] to [9]. Each drawer corresponds to a memory location in the PLC. When using 10 locations of ALLM memory, first declare ALLM[10], and then indicate the individual drawers as ALLM[0]...ALLM[9].

■ Accessing a Discrete Array

To access the elements of a discrete array, a modifier [n] must be attached to each element. To access the modifier, it is assigned an element number, however the first element number in an array must be "0".

Ex. To access discrete array variable **Discrete_Array**'s 5th element, you would enter **Discrete_Array[4]**.

■ Accessing an Integer/Integer Array

Integers and Integer Arrays can be accessed via array elements, bits, bytes and words. To access using bits, bytes and words, the following suffix are used. The modifier [m] is used to denote the position of the element in the array being accessed.

Access Item/Unit	Suffix
Bit	.X [m]
Byte	.B [m]
Word	.W [m]

Also, as with the Discrete Array, the modifier [n] can also be used to access any of the array's elements. This method is can also be combined with the bit, byte and word access method. Thus, in order to access the Integer Array variable **Integer_Array**'s **n+1** element's **m+1** bit, the wording **Integer_Array[n].X[m]** is used.

Ex. To access **Integer_Variables** 7th bit, type “**Integer_Variables.X[6]**”.

To access the integer array **Integer_Array**'s 62nd bit, type “**Integer_Array.X[61]**”.

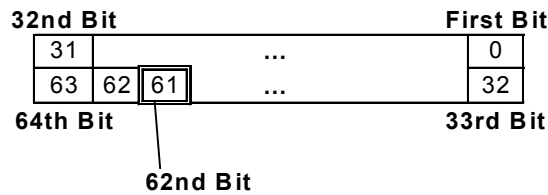

Also, for **Integer_Array[1].X[29]**:

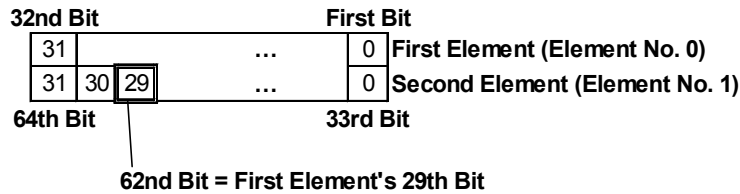

Since **Integer_Array.X[61] = Integer_Array[1].X[29]**, both can be used to access **Integer_Array**'s 62nd bit.

- When accessing **Integer_Array**'s 6th byte, both **Integer_Array.B[5]** and **Integer_Array[1].B[1]** can be used.
- When accessing **Integer_Array**'s 5th word, both **Integer_Array.W[4]** and **Integer_Array[2].W[0]** can be used.

■ Accessing a Real Array

Real Arrays can be accessed via array elements. To access the elements of a Real array, a modifier (n) must be attached to each element, which represents the element number, "0", however, is used for the first element in the array.

Ex. When accessing the Real array's 5th element, type “**Real_Array[4]**”.

Note: GP-PRO/PB III can handle 2048 GLC variables. The elements of the array become single variables. For example, an array with 5 elements becomes 5 variables.

Up to 2048 GLC variables can be used in GP-PRO/PBIII for Windows.

■ Array Indirect Access

The element no. indicated in square brackets [] can be indirectly expressed with a real variable. For example, if 1 is substituted for N in a MOV instruction (as in the following circuit), and 1 is added to 2 with an ADD instruction and then substituted in A[N], then 3 is assigned to A[1].

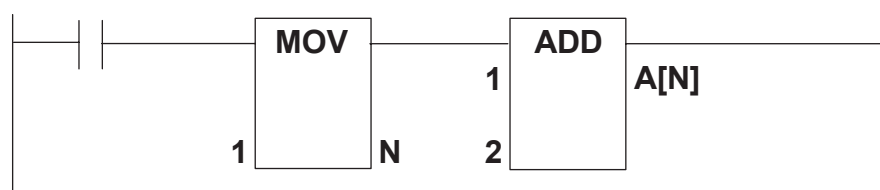

3.3

Variable Names

Variable names can be designated by the user. When designating variable names, please be aware of the following limitations.

- Variable names can be up to 20 bytes (10 characters)
- No differentiation is made between upper and lower case characters. However, the order in which words are registered will determine if they are valid or not.
Ex.) If the word “TANK” is entered prior to “tank”, the word “tank” can be entered, however it will be invalid.
- Variable Names can use numbers, except for the first character.
- The underscore cannot be used 2 or more in series like this: “_ _”.
- Only the underscore “_” special character can be used.
- Since it is a reserved character, the # sign cannot be used.
- Since the names LS and LSS are reserved for use by the GLC’s system in the System Data Area, the Read Area, and for Special Relays, they cannot be used for variable names.

▼Reference▲ *Refer to Chapter 6 - LS Area Refresh*

▼Reference▲ *For information about Variable Settings, refer to Pro-Control Editor’s Operation Manual.*

4

System Variables

The following table provides a list of the Controller's predefined System Variables.

4.1

System Variable List

System Variables are used to display the Controller's current condition, and effect its operation. System variables perform like normal variables, however, since they are reserved they cannot be automatically created and deleted.

Group	System Variable	Explanation	Initial Value	Variable Name
Data	#AvgLogTime	Displays the average Logic Time once every 64 scans. (Unit:ms)	0	Integer
	#AvgScantime	Displays the latest Logic Time (Read, Perform, Write, GP processing) (Unit:ms)	0	Integer
	#EditCount	Currently not used by GLC	-	Integer
	#Fault	Used to stop the performance of an Error Handler sub-routine.	0	Discrete
	#ForceCount	Counts the no. of times a variable is forcefully changed.	0	Integer
	#IOStatus	Shows the I/O Driver's condition.	-	Integer [10]
	#LogicTime	Displays the latest Logic Scan Time (Read, Perform, Write) Unit:ms	0	Integer
	#PlatForm ^{*1}	Indicates the Controller's Platform	-	Integer
	#ScanCount	Excluding the current scan, counts the number of scans performed.	0	Integer
	#ScanTime	Displays the latest Logic Scan Time (Read, Perform, Write, GP processing) (Unit:ms)	0	Integer
	#Status	Indicates the Controller's current status.	-	Integer
	#StopPending	Currently not used by GLC	-	Discrete
	#Version	Displays the Controller's version data.	-	Integer
	#WCLScan	Currently not used by GLC	-	Integer
#WCLStatus	Currently not used by GLC	-	Integer	

*1 This system variable is not supported by the GLC100 Series units.

Group	System Variable	Explanation	Initial Value	Variable Name
Errors	#FaultCode	Displays the latest Error code.	-	Integer
	#FaultRung	Displays the rung where the error occurred.	-	Integer
	#IOFault	Turns ON when an Error occurs.	-	Discrete
	#Overflow	Turns ON when an overflow occurs due to arithmetic commands or to conversion of a variable from Real to Integer.	0	Discrete
Settings	#Command	Changes the Controller's mode.	0	Integer
	#DisableAutoStart	Defines the mode entered when the GLC starts up.	-	Discrete
	#FaultOnMinor	Setting to control the completion of the logic performed when a minor error occurs.	0	Discrete
	#PercentAlloc	Defines the Percent Scan's percentage. (Unit: %)	0	Integer
	#PercentMemCheck	Currently not used by the GLC.	-	Integer
	#StopScans	Currently not used by the GLC.	-	Integer
	#TargetScan	Sets the Constant Scan Time. (Unit: ms)	-	Integer
	#WatchdogTime	Sets the Watchdog Timer's value. (Unit: ms)	-	Integer

For details on system variables, see “Pro-Control Help”.

5

Instructions

Here, the Pro-Control Editor instructions are explained

5.1 Instruction List

The Instructions supported by the Pro-Control Editor software are as follows.

■ Bit Operation Instructions

Instruction	Type	Symbol	Function
NO	Normally Open		Allows power to pass when the contact turns ON.
NC	Normally Closed		Allows power to pass when the contact turns OFF.
OUT/M ^{*1}	Output Coil/Retention Coil		Turns physical output devices or internal discrete variables and expressions ON or OFF.
NEG/NM ^{*1}	Negated Coil/Negated Retention Coil		Turns a variable OFF if the coil receives power, and ON if it doesn't.
SET/SM ^{*1}	Latch Coil/ Latch Retention Coil		Turns a variable ON if the coil receives power. Stays ON until receiving another explicit instruction.
RST/RM ^{*1}	Unlatch Coil/ Unlatch Retention Coil		Turns a variable OFF if the coil receives power. Stays OFF until receiving another explicit instruction.
PT	Positive T ransition		Allows power to pass if the variable was OFF during the previous scan, but is ON now.
NT	Negative T ransition		Allows power to pass if the variable was ON during the previous scan, but is OFF now.

**1 For the instructions explained above, when a variable is designated as retained, it is automatically changed to one of the right side instructions. Thus, when entering data in this screen, be sure to use one of the left side (non-retained) instructions.*

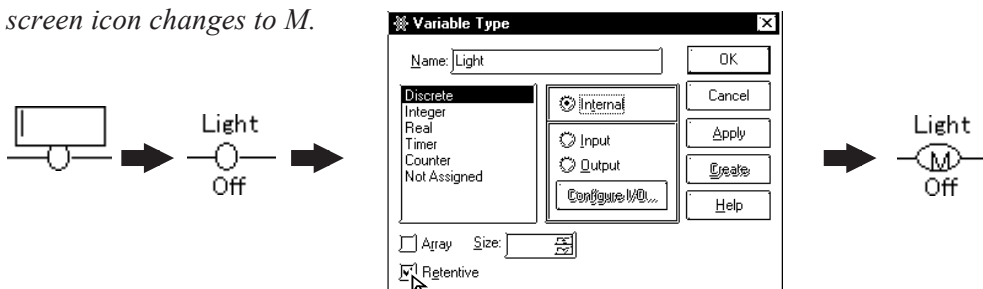

Ex: As shown here, when an OUT instruction's variable is designated as retained, the screen icon changes to M.

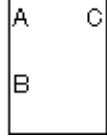
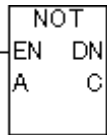

■ Arithmetic Operation Instructions

Instruction	Type	Symbol	Function
AND	Logical Multiply		A and B -> C Normal Continuity
OR	Logical Add		A or B -> C Normal Continuity
XOR	Exclusive Logical Add		A xor B -> C Normal Continuity
NOT	Bit Negation		\bar{A} -> C Normal Continuity

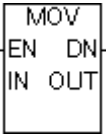
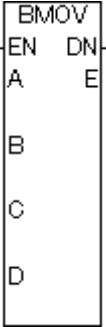
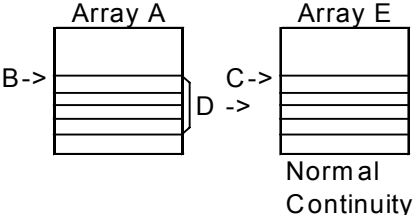
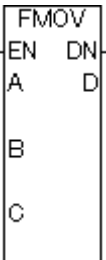
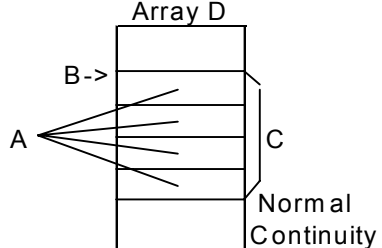
■ Movement Instructions

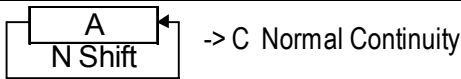
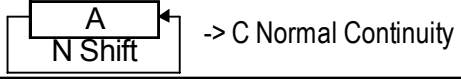
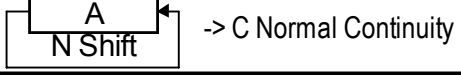
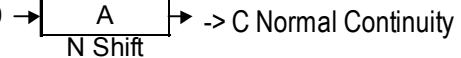
Instruction	Type	Symbol	Function
MOV	Move		IN -> OUT Normal Continuity
BMOV	Block Move		 Normal Continuity
FMOV	File Move		 Normal Continuity
ROL	Rotate Left		 -> C Normal Continuity
ROR	Rotate Right		 -> C Normal Continuity
SHL	Shift Left		 -> C Normal Continuity
SHR	Shift Right		 -> C Normal Continuity

■ **Mathematical Instructions**

Instruction	Type	Symbol	Function
ADD	Add		A + B -> C Normal Continuity
SUB	Subtract		A - B -> C Normal Continuity
MUL	Multiply		A x B -> C Normal Continuity
DIV	Divide		A ÷ B -> C Normal Continuity
MOD	Residual Processing		A % B -> C Normal Continuity
INC	Increment		A + 1 -> A Normal Continuity
DEC	Decrement		A - 1 -> A Normal Continuity
EQ	Equal To (=)		When A = B, Continuity
GT	Greater Than (>)		When A < B, Continuity
LT	Less Than (<)		When A > B, Continuity
GE	Greater Than or Equal To (>=)		When A > or = B, Continuity
LE	Less Than or Equal To (<=)		When A < or = B, Continuity
NE	Not Equal (!=)		When A not= B, Continuity

■ **Timer and Counter Instructions**

Instruction	Type	Symbol	Function
TON	Time ON-Delay		Refer to Pro-Control Help
TOF	Timer OFF-Delay		Refer to Pro-Control Help
TP	Timer Pulse		Refer to Pro-Control Help
CTU	Count UP		Refer to Pro-Control Help
CTD	Count DOWN		Refer to Pro-Control Help
CTUD	Count UP/DOWN		Refer to Pro-Control Help



**The GLC's ScanTime includes the following error:
GLC 100 - approx. 0.2%, GLC 300 - 0.2%**

■ Convert Instructions

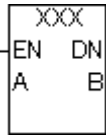
Instruction	Type	Symbol	Function
BCD	BCD Conversion		A -> BCD conversion -> B Normal Continuity
BIN	Binary Conversion		A -> Binary conversion -> B Normal Continuity

Instruction	Type	Symbol	Function
JMP	Jump	->>label name	Jumps to a label
JSR	Jump to Subroutine	-<RETURN>-	Jumps to subroutine
RET	Return from Subroutine	->>Subroutine Name<<-	Returns to called JSR command.

6

L/S Area Refresh

6.1

Overview

■ L/S Area Refresh Feature

The GLC unit, like the GP uses the LS Area's System Data Area to control the changing of screens, the sounding of buzzers, etc. These are processed as GP Display features.

Thus, when you wish to use the above screen change and buzzer functions with the GP's Control functions, i.e. the LS Area's "mapped" functions, the LS Area must be registered as a variable, with the Control and Display features operating via the sharing of LS area data.

This is defined as the "LS Area Refresh".

It is also possible to use an area outside of the System Data Area if the GLC Controller features or Display features need to share data.

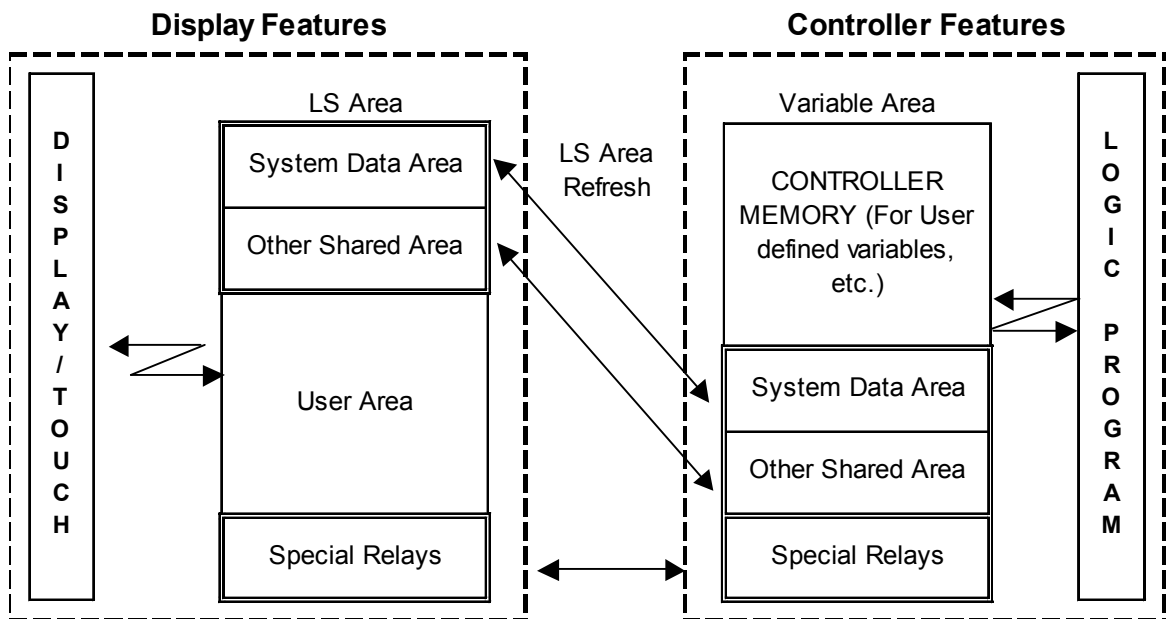

6.2 LS Area Refresh Settings

In order to use the logic program to designate the LS Area, the desired variable must first be registered in the Pro-Control Editor. The following text will explain this procedure.

■ Variable Registration

Click on the Pro-Control Editor [Data] menu's [Variable Type] selection and the following dialog box will appear.

The variables handled in the LS Area are registered as an internal integer and array.

In this example the size of a System Area array is 20 words, and any additional data that will be shared is added to that amount. Ex. If the user wishes to have 16 words of data shared outside of the System Data Area, the calculation would be 16 words of data, plus the System Data Area's 20 words, for a total of 36 words.

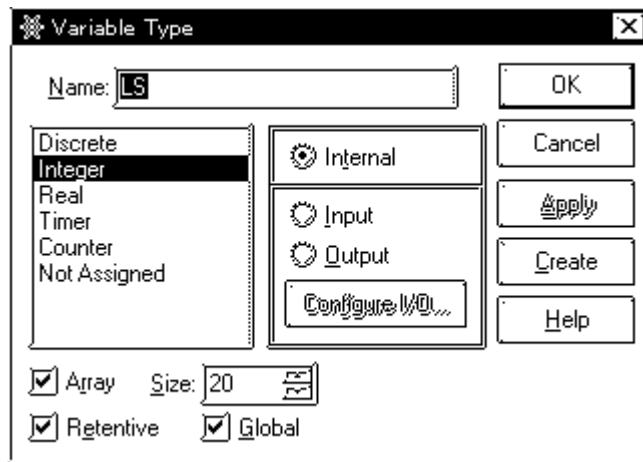

Note: The Special Relay Area is called the LSS area.

6.2.1 System Data Area

The System Data area's structure is shown in the following chart. This area is used for changes in screens, or to turn the GLC's backlight ON/OFF, via the refreshing of data via the controller's ladder logic program.

Reference Refer to the GP-PRO/PBIII PLC Connection Manual (included with screen creation software)



This area can be used by the GLC's internal integer array variables, that are registered via the Pro-Control Editor software.

■ Direct Access Method

Addresses and variable names used here assume all the System Data Area items designated in the GLC's initial settings are selected.

Area Function	LS Address	Var. Name	Contents	Bit	Detail
GLC ↓ PLC E x c l u s i v e W r i t i n g A r e a	LS0000	LS[0]	Display Screen Number	1 to 8999	(However, 1 to 1999 when using BCD input)
	LS0001	LS[1]	Error Status Each bit changes to reflect the GP error status. When an error occurs, the bit is set ON. A bit that has turned ON remains ON until the power is turned OFF and back ON, or until RUN mode is re-entered from OFFLINE mode.	0,1	Not used
				2	System ROM/RAM
				3	Memory Checksum
				4	SIO Framing
				5	SIO Parity
				6	SIO Over-run
				7,8	Not used
				9	Memory requires Initialization
				10	Timer Clock Error
				11	PLC
	12 to 15	Not used			
	LS0002	LS[2]	Current YEAR, BCD 2 digits	Last two digits	
	LS0003	LS[3]	Current MONTH, BCD 2 digits	01 to 12 (month)	
	LS0004	LS[4]	Current DAY, BCD 2 digits	01 to 31 (date)	
	LS0005	LS[5]	Current TIME, BCD 4 digits	00 to 23 hr, 00 to 59 min	
	LS0006	LS[6]	Status	0,1	Reserved
				2	Now Printing
				3	Writes a set value
				4 to 6	Reserved
7				PLC monopoly	
8				K-tag entry error	
9				Display 0: Possible 1: Not Possible	
10 to 15	Reserved				
LS0007	LS[7]	Reserved			

For more information, see PLC Connection Manual.

▼Reference▼ Refer to the PLC Connection Manual 1.1.4 Contents and Range of System Data Area.

Area Function	LS Address	Var. Name	Contents	Bit	Detail	
PLC ↓ GLC E x c l u s i v e R e a d i n g A r e a	LS0008	LS[8]	Change Screen Number	1 to 8999	(However, 1 to 1999 when using BCD input)	
	LS0009	LS[9]	Screen Display On/Off	FFFFh:	Screen clears almost immediately. 0h: Screen turns ON. All other bits are reserved.	
	LS0010	LS[10]	Clock's YEAR set value, BCD 2 digits (+flag)	Last 2 digits (bit #15 is the clock's data write change flag)		
	LS0011	LS[11]	Clock's MONTH set value, BCD 2 digits	01 to 12		
	LS0012	LS[12]	Clock's DATE set value, BCD 2 digits	01 to 31		
	LS0013	LS[13]	Clock's TIME set value, BCD 4 digits	00 to 23 Hr: 00 to 59 Min		
	LS0014	LS[14]	Control	0	Backlight OFF	
				1	Buzzer ON	
				2	Starts printing	
				3	Reserved	
				4	Buzzer 0: Enabled, 1: Disabled	
				5	AUX Output 0: Enabled, 1: Disabled	
				6	Reserved	
				7	PLC monopoly 0: Disabled, 1: Enabled	
				8	VGA Display 0: Disabled, 1: Enabled	
				9,10	Reserved	
				11	Hard copy output 0: Enabled, 1: Disabled	
				12 to 15	Reserved	
	LS0015	LS[15]	Reserved	Set to 0		
	LS0016	LS[16]	Window Control	0	Display - 0: OFF, 1: ON	
1				Changing the order of window overlapping 0: Possible 1: Not Possible		
2 to 15				Reserved		
LS0017	LS[17]	Window Registration Number	Global Window registration number selected by Indirect setup (Bin/BCD)			
LS0018	LS[18]	Window Display Position (X coordinate data)	Global Window display coordinates selected by Indirect setup (Bin/BCD)			
LS0019	LS[19]	Window Display Position (Y coordinate data)				

For more information, see PLC Connection Manual.

Reference Refer to the PLC Connection Manual 1.1.4 Contents and Range of System Data Area.

■ **Memory Link Method**

Addresses and variable names used here assume all the System Data Area items designated in the GLC's initial settings are selected.

LS Address	Var. Name	Detail	Function	Bit	Particulars
LS0001	LS[1]	Status		0, 1	Reserved
				2	Now Printing
				3	Writes a set value
				4 to 7	Reserved
				8	K-tag entry error
				9 to 15	Reserved
LS0002	LS[2]	Error Status Each bit changes according to the GP error function. When an error occurs, the corresponding bit will turn on.		0, 1	Unused
				2	System ROM/RAM
				3	Screen Memory Checksum
				4	SIO Framing
				5	SIO Parity
				6	SIO Overrun
LS0003	LS[3]	A bit that has turned ON remains ON until the power is turned OFF and back ON, or until RUN mode is re-entered from OFFLINE mode.		7, 8	Unused
				9	Initialization of Internal Memory Checksum Necessary
				10	Timer Lock Error
				11 to 15	Unused
LS0004	LS[4]	Clock Data (Year)	"Year / Month / Day / Hour / Minute" Data is stored in BCD's 2digits. (E.g.) 98/02/01 17:15	0 to 7	Stores the last 2 digits of the Calendar year
		8 to 15		Unused	
LS0005	LS[5]	Clock Data (Month)		0 to 7	Stores 01 to 12 (Month) as 2 BCD digits
				8 to 15	Unused
LS0006	LS[6]	Clock Data (Day)		0 to 7	Stores 00 to 31 (Day) as 2 BCD digits
				8 to 15	Unused
LS0007	LS[7]	Clock Data (Hour)		0 to 7	Stores 00 to 23 (Hour) as 2 BCD digits
				8 to 15	Unused
LS0008	LS[8]	Clock Data (Minute)	0 to 7	Stores 00 to 59 (Minute) as 2 BCD digits	
			8 to 15	Unused	
LS0010	LS[10]	Interrupt Output (Touch OFF)	If you Write in word data, the bottom 8 bits will be output as an interup code after Touch OFF. However FFh will not be output.		
LS0011	LS[11]	Control		0	Backlight
				1	Buzzer ON
				2	Starts Printing
				3	Reserved
				4	Buzzer --- 0:enabled 1: disabled
				5	AUX Output --- 0:enabled 1: disabled
				6	Interrupt Output when touching panel to turn
				7	Reserved
				8	VGA display --- 0: Disabled 1: Enabled
				9, 10	Reserved
				11	Hard copy output --- 0: Enabled 1:
				12 to 15	Reserved

For more information, see PLC Connection Manual.

Reference Refer to the PLC Connection Manual 3.1.2 Contents and Range of System Data Area.

Chapter 6 - L/S Area Refresh

LS Address	Var. Name	Detail	Function	Bit	Particulars
LS0012	LS[12]	Screen Display ON/OFF	FFFFh : Screen clears almost immediately 0h: Screen turns ON		
LS0013	LS[13]	Interrupt Output	Using a Touch Tag or other method to write absolute value data from GP causes an output of the interrupt code using the contents of the bottom 8 bits (Will not out put FFh)		
LS0015	LS[15]	Screen Display No.	Write the Screen No. in binary to change the screen display	0 to 14	Screen change number, 1 to 8999.
				15	Forced Screen Change
LS0016	LS[16]	Window Control		0	Display -- 0: OFF 1: ON
				1	Changing ghe order of window overlapping -- 0: Possible 1: Not Possible
				2 to 15	Reserved
LS0017	LS[17]	Window Registration No.	Global Window registration number selected indirectly (BIN/BCD)		
LS0018	LS[18]	Window Display Position (X-coordinate)	Global Window display position reached indirectly (BIN/BCD)		
LS0019	LS[19]	Window Display Position (Y-coordinate)			

For more information, see PLC Connection Manual.

▼Reference▲ *Refer to the PLC Connection Manual 3.1.2 Contents and Range of System Data Area.*

6.2.2 Special Relays

Special Relays have the following structure.



This area can be used by the GLC's internal integer array variables (LSS), which are registered via the Pro-Control Editor software.

For information about the Special Relays, refer to:

GP-PRO/ PBIII PLC Connection Manual (included with Reference screen creation software)

Direct Access Method



Do NOT use any areas designated as Reserved.

LS Address	Var.* Name	Contents
LS2032	LSS[0]	Shared Relay Data
LS2033	LSS[1]	Base Screen Data
LS2034	LSS[2]	Reserved
LS2035	LSS[3]	Binary Counter - 1 second
LS2036	LSS[4]	Tag Scan Time
LS2037	LSS[5]	Data Transfer Scan Time
LS2038	LSS[6]	Tag Scan Counter
LS2039	LSS[7]	Data Transfer Error Code
LS2040	LSS[8]	Token Pass Speed (Max.)
LS2041	LSS[9]	Token Pass Speed (Current)
LS2042	LSS[10]	Reserved
LS2043	LSS[11]	
LS2044	LSS[12]	
LS2045	LSS[13]	
LS2046	LSS[14]	
LS2047	LSS[15]	

* When using the GLC to access.

Memory Link Method



Do NOT use any areas designated as Reserved.

LS Address	Var. Name	Contents
2032	LSS [0]	Share Relay Data
2033	LSS [1]	Reserved
2034	LSS [2]	
2035	LSS [3]	Binary Counter - 1 second
2036	LSS [4]	Tag Scan Time
2037	LSS [5]	Reserved
2038	LSS [6]	Tag Scan Counter
2039	LSS [7]	Reserved
2040	LSS [8]	
2041	LSS [9]	
2042	LSS [10]	
2043	LSS [11]	
2044	LSS [12]	
2045	LSS [13]	
2046	LSS [14]	
2047	LSS [15]	

* When using the GLC to access.

6.3 GLC and PLC Data Sharing

The System Data Area can use up to 20 words, and the Write Area can use up to 16. Each area's addresses are decided depending on the size setvv for that area. However, the GLC's Controller feature's Read Area must always start from LS0020 (LS[20]).

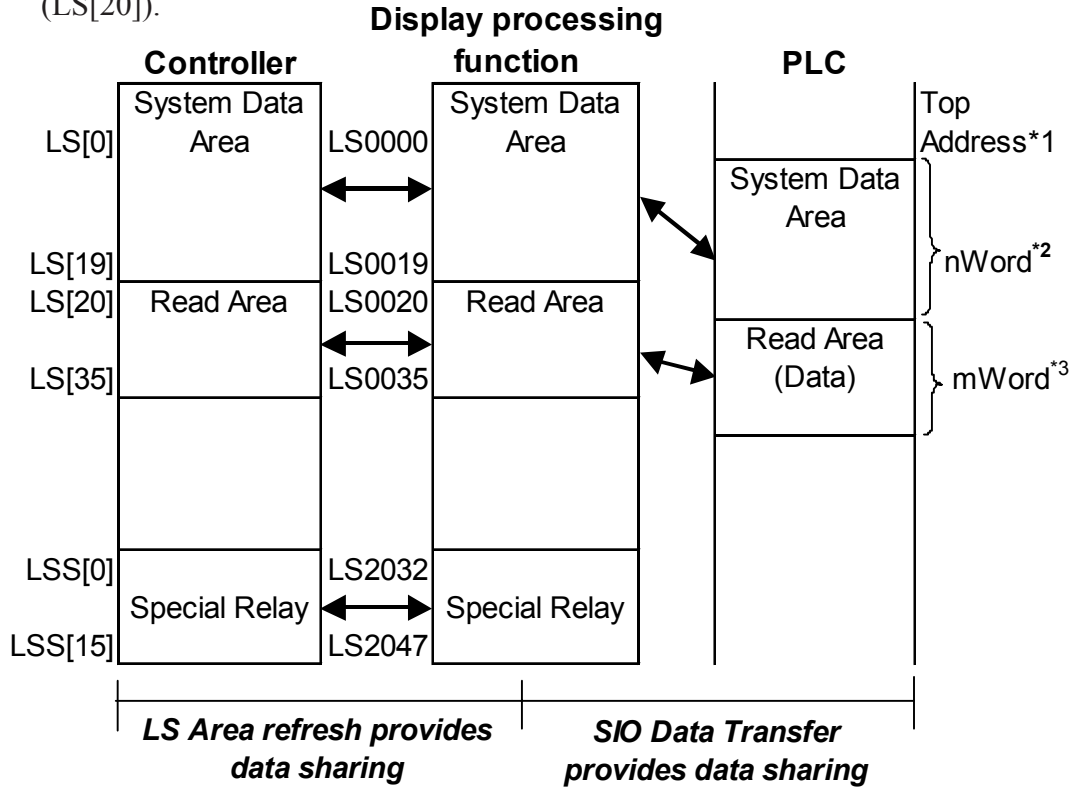

When data is updated for the same variable in the Control area's Logic Program, GLC's Tags and External PLC's Logic Program, the timing will determine which data is remaining.



When the Read Area is used efficiently and the GLC and PLC share data, the GLC can be used as the PLC's slave device, which also allows the use of a FA type POP unit, or an I/O data collection unit.

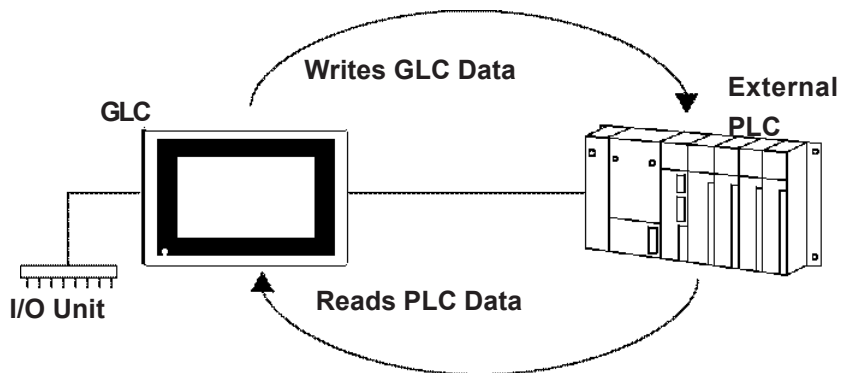

*1 Start Address defined in Initial Settings.
 *2 $n = 0$ to 20 Depends on the System Data Area setting items selected in Initial Settings .
 *3 $m = 0$ to 16 Depends on size of Read Area designated in Initial Settings.

6.3.1 Read Area

This area is used when performing regular data transfer with the PLC, regardless of the currently displayed screen data.

This area is also used when sharing data between the PLC and the GLC.

This area's size can be set from 0 to 16 words. Please use the GLC's OFFLINE menu to set the Initial Settings area's Read Area Size.

Reference Refer to *GLC Series Users Manual* (Sold Separately)



Note:

When using this area, be sure to first register all variable names used for the Integer Arrays via the Pro-Control Editor software. Be sure to make the size of the array equal to "20" + "GLC's Initial Setting Read Area Size".



Important

When writing data to this area in the GLC, be sure that data written from Tags, and data written from the Controller's Logic Program do not overlap or conflict.

6.3.2 LS Area Refresh Cautions

The LS Area Refresh feature is used when you wish to use the Controller feature to control the system area, or to view Read Data from an External PLC. Digital recommends that you use your data send/receive related Initialize area or Operation Designation Change parameter settings to control the refreshing of data in this area, rather than refreshing LS0000 to LS0035 and LS2032 to LS2047's data intermittently via the Controller feature.

Please be aware that increasing the frequency of LS Area data refreshing can lead to errors like "External PLC Communication Error".

MEMO

7

I/O Drivers

7.1

Overview

To perform external I/O, the GLC's expansion unit must be attached and its related I/O drivers must be installed. For detailed I/O Driver information,

Reference refer to *Pro-Control Editor Operation Manual*.



Note: When an I/O error occurs and the Controller stops, please create the following Logic Program. There is, however, a lag of approximately one scan, from when the error is detected until the Logic Program stops.

In the following example, an I/O error is detected with #IOFault, and logic execution is stopped by assigning 1 to #Command.



When an I/O error occurs, #IOFault will turn ON. For detailed error information, refer to the #IOStatus data.

7.2 DIO Driver

This section explains the GLC OFFLINE screen's DIO menu. Be sure the DIO unit is securely attached prior to using any of the DIO unit's features.

For instructions on how to move to the OFFLINE menu screen,

Reference *GLC Series Users Manual* (Sold separately)

7.2.1 DIO Unit Self-Diagnosis

This area explains how to use the DIO unit's Self-diagnosis feature.

Reference for detailed information, refer to *the GLC Series Users Manual* (Sold separately)

Touch the OFFLINE screen's Controller Menu to call up the [DIO Menu] area

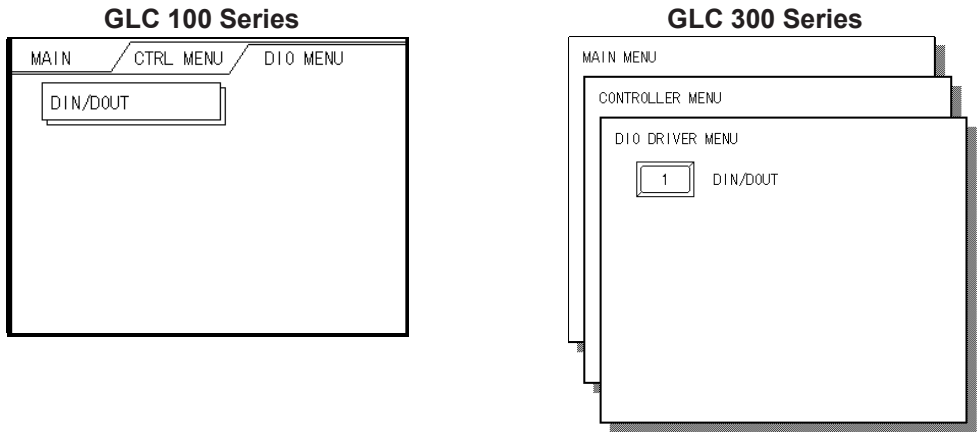

Next, touch the DIN/DOUT key to call up the following screen.

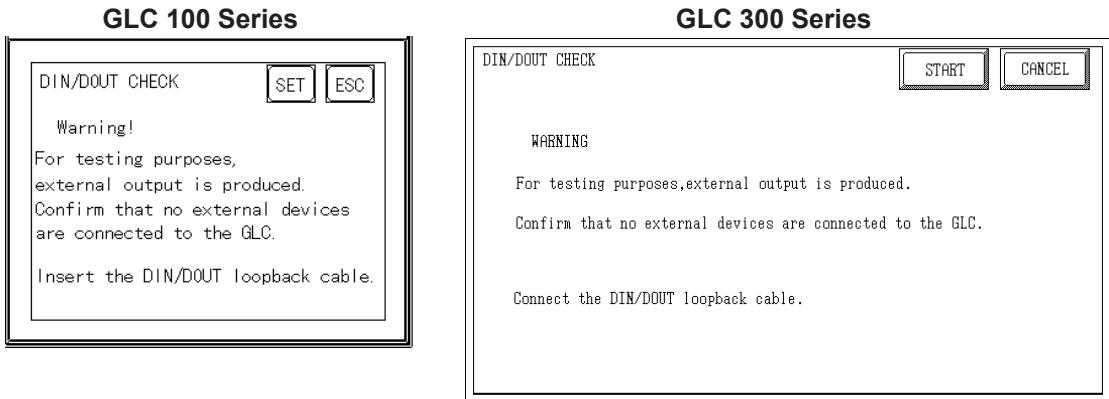

Touching either the Set or Start keys will start the self-diagnosis.

This check sends an output signal from the output unit to the input unit. Therefore, prior to performing this check, be sure to attach the DIN/DOOUT loopback cable.



When switching to the offline mode or resetting from the logic program RUN state, the I/O signal may turn to OFF. Please be aware of the possibility of the I/O signal turning to OFF.

◆ Loopback Cable Creation

Use the following diagram when creating your DIN/DOUT loopback cable.

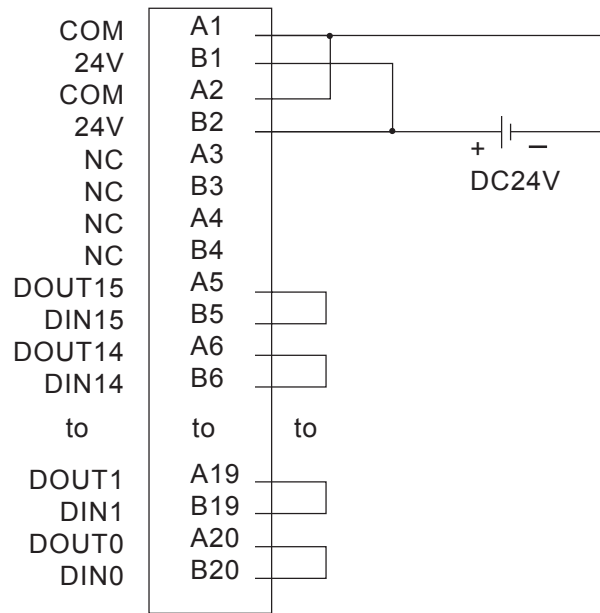

Recommended Products

Connection Type	Maker	Model Number
Soldered Type	Fujitsu	FCN-361J040-AU (Connector)
		FCN-360C040-B (Cover)
Crimped Type	Fujitsu	FCN-363J040
		FCN-363J-AU/S
		FCN-360C0404-B
Terminal Block Unit Type	Mitsubishi	A6TBX36 (Terminal Block Unit)
		AC**TB (Cable) (* = cable length)
	Yokogawa	TA40-ON

7.2.2 I/O Monitor (I/O Connection Check)

On the DIO driver menu touch [I/O Monitor] to call up the following screens.

<When [I/O] Monitor has been selected>

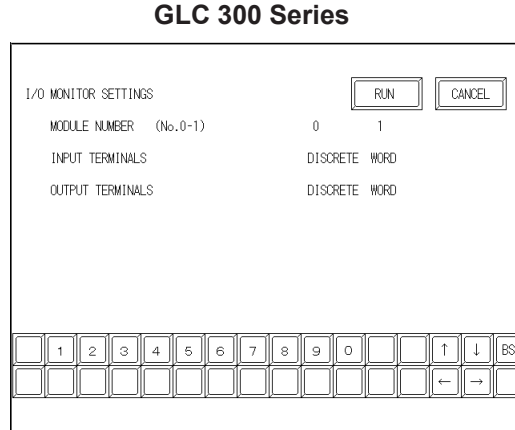
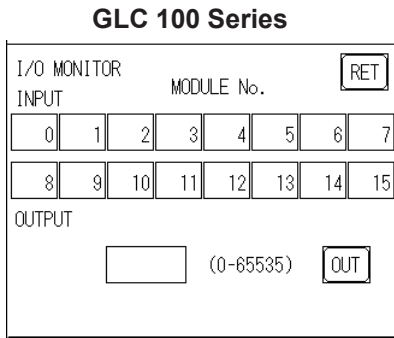

Select the Module No., either 0, or 1. (The “0” unit is the unit attached directly to the GLC, and the “1” unit is attached to the back of the “0” unit.

Select the Input Variable Type, either Discrete or Word.

Select the Output Variable Type, either Discrete or Word.

For example, if you entered a Module No. of “0”, an Input Variable Type of “Discrete” and an Output Variable Type of “Word”, and touched the screen’s upper right corner “RUN” button, the “I/O Monitor” screen would appear.

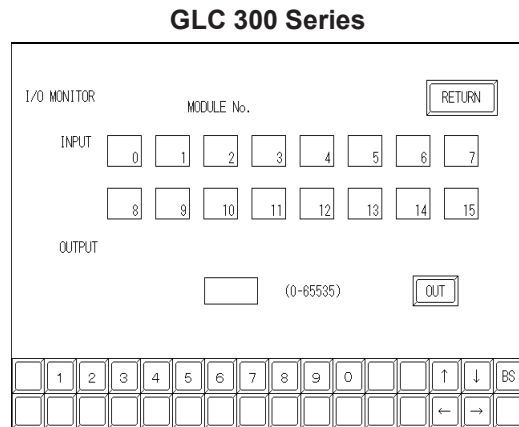
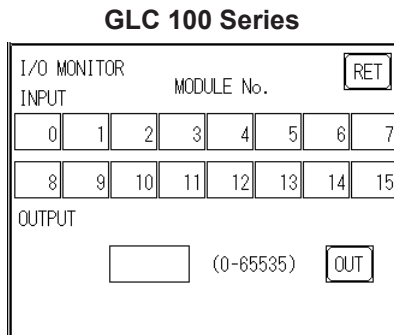

When the Input Variable Type is “Discrete”, the input terminal (S-No.) will appear in reverse color. When the Output Variable Type is [WORD], use the ten-key input pad to enter your data. When using a GLC100 series unit, simply touch the data entry field and the ten-key input pad will appear. After finishing your data entry, touch the [OUT] square to output your data. All data entry is in decimal values.

*1 The I/O Monitor feature cannot be used with the CGP070-D112 unit.

7.2.3 Troubleshooting

This area explains how to solve possible DIO unit problems.

■ DIO Unit Input Errors

Error Type	Possible Cause	Solution
Input monitor lamp is ON, but no input can be performed.	DIO Unit is defective	Replace DIO Unit
	Program is incorrect	Correct program
Input monitor lamp is OFF and no input can be performed.	DIO Unit is defective	Replace DIO Unit
	Input common line is incorrectly wired.	Common line wiring check. Common line breakage check. Common terminal looseness check.
	External input power is incorrect.	Provide the correct voltage.
	DIO unit is not correctly attached.	Attach the DIO unit securely.
	Connector is not securely attached.	Attach the connector securely.
All input lines do not turn OFF	DIO Unit is defective	Replace DIO Unit
Designated Input lines do not turn ON.	DIO Unit is defective	Replace DIO Unit
	Program is incorrect	Correct the program.
	Input wiring is incorrect.	Check common line wiring. Check common line breakage. Check common terminal for looseness.
	External unit is defective.	Replace the unit.
	Input ON period is too short.	Lengthen the Input ON time.
Designated Input lines do not turn OFF.	DIO Unit is defective	Replace DIO Unit
	Program is incorrect	Correct the program.
Input area randomly turns ON or OFF.	External Input voltage is incorrect	Provide the correct voltage.
	Input terminal screws are loose.	Tighten the terminal screws.
	Program is incorrect	Correct the program.
	Connector is not securely attached.	Attach the connector securely.
	Noise is causing unit mis-operation.	Reduce the noise level. Attach a surge killer. Use a shielded cable.

■ DIO Unit Output Errors

Error Type	Possible Cause	Solution
Output monitor lamp is ON, but no output can be performed	DIO unit is defective	Replace DIO unit
	Output common line is incorrectly wired.	Output line wiring check. Output line breakage check. Output terminal looseness check.
	Load current is incorrect.	Provide the correct current.
	Connector is not securely attached.	Attach the connector securely.
Output monitor lamp is OFF and no output can be performed	DIO unit is defective	Replace DIO unit
	Program is incorrect. Output area is completely OFF.	Correct program.
	DIO unit is not correctly attached.	Attach the DIO unit securely.
Output lines do not turn OFF	DIO unit is defective	Replace DIO unit
Designated output lines do not turn ON	DIO unit is defective	Replace DIO unit
	Output wiring is incorrect.	Check output line wiring. Check output line breakage. Check output terminal for looseness.
	External unit is defective.	Replace unit.
Designated output lines do not go OFF	DIO unit is defective	Replace DIO unit
	Current leakage, residual voltage causes incorrect recurrence.	Change design of external device. I.e. Attach dummy resistor, etc.
Output area randomly turns ON/OFF	Load voltage is incorrect	Correct voltage load.
	Output terminal screws are loose.	Tighten the terminal screws.
	Program is incorrect. Output commands are overlapping.	Correct the program.
	Connector is not securely attached.	Attach the connector securely.
	Noise is causing unit mis-operation.	Reduce the noise level. Attach a surge killer. Use a shielded cable.

■ Error Codes

I/O errors are Read/Write errors. When I/O errors occur, the Controller writes an error code to the #IOStatus variable. The Logic program continues to operate. The following explanation of possible error causes and solutions for when the DIO unit is attached to the GLC.

◆ Setting Errors

Error Code	Contents	Solution
501	Internal variable error allocated to I/O terminal.	Reset the variable used.
502	External variable error allocated to I/O terminal.	
503	Output variable error allocated to I/O terminal.	
504	Discrete variable error allocated to analog terminal.	
505	Integer variable error allocated to discrete terminal.	
506	Variable type not supported by driver.	Correct the variable type.
801	Terminal numbers are duplicated.	2 or more terminals are using the same terminal number, possibly causing transfer failure. Download the WLL file again.
802	Multiple modules are used.	2 DIO units are using the same module number. Reset these numbers so they do not overlap.
803	Module number has exceeded 1.	Set a module number from 0 to 1.
804	Unit number starts from 1.	Set the DIO unit nearest the GLC rear face to "0".

◆ Initialization Errors

Error Code	Contents	Solution
821	The number of DIO units registered in the WLL file and the actual number of DIO units connected is different.	Correct the number of connected DIO units.
822	No module "0". No DIO unit is near the GLC unit.	Confirm that the DIO unit is securely connected to the GLC and correct the DIO driver settings.
823	Analog unit setting error	Check to see if communication line is disconnected, power is not supplied to the I/O unit, or the I/O unit is malfunction.

◆ Run Time Errors

Error Code	Contents	Solution
840	Module "0" Read-out data is incorrect. After 2 successive Read attempts, the GLC has detected that value of the DIO unit nearest the GLC's rear face is incorrect.	Lengthen the time of the Input signal 's ON period.
841	Module "1" Read-out data is incorrect. After 2 successive Read attempts, the GLC has detected that value of the DIO unit nearest the GLC's rear face is incorrect.	Lengthen the time of the Input signal 's ON period.
842	Module 0 output data is incorrect. Incorrect output data was detected by an internal loopback check from the DIO unit near the GLC.	Ensure that there are no noise-related or other ill effects.
843	Module 1 output data is incorrect. Incorrect output data was detected by an internal loopback check from the DIO unit near the GLC.	Ensure that there are no noise-related or other ill effects.

◆ Internal Errors

Error Code	Contents	Solution
850 : 864	Driver Error. A major system error has occurred.	Record the Error Number and contact your local Digital dealer for service.

7.3 Flex Network I/F Driver

Here, the GLC's OFFLINE mode Flex Network driver menus are described.

Prior to executing any Flex Network Driver menu instructions, be sure to download the Flex Network driver from Pro-Control Editor software in your PC. Also, be sure to confirm that the Flex Network I/F unit has been already been attached to the back of your GLC unit.

To change to the GLC's OFFLINE mode,

Reference Your GLC unit's Users Manual (sold separately).

7.3.1 Flex Network I/F Unit Self-Diagnosis

Select [FLEX NETWORK DRIVER] in the GLC OFFLINE mode's [CONTROLLER MENU]. The following [FLEX NETWORK DRIVER MENU] window will then appear.

<To select communication check>

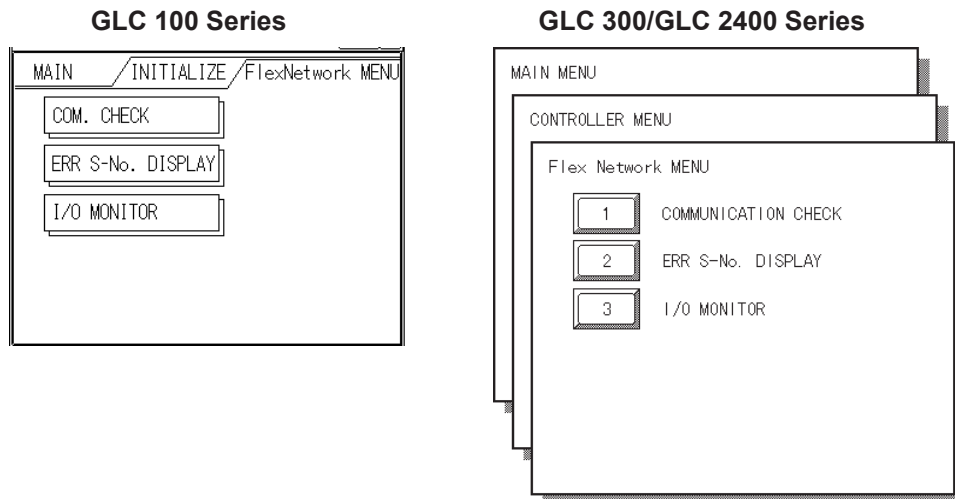

When the Logic Program changes from the RUN condition to either the OFFLINE mode or RESET, The GLC or the I/O signal will be performed as shown below, regardless of the Output Hold Setting. Be sure to consider this when changing to either the OFFLINE or RESET modes.

GLC Condition	RUN	OFFLINE	RUN
Analog Output	Output from Logic Program	No Analog Output	Output from Logic Program
I/O Signal	Output from Logic Program	No Analog Output	Output from Logic Program
No Analog Output	Output from Logic Program	No Analog Output	Output from Logic Program

Please remember that the Reset mode's I/O signal OFF timing is not fixed.

Here, the number of the Flex Network I/O units that have been connected to the Flex Network I/F units, as well as the S-Nos. that have been connected to each I/O unit will be checked.

Via the communication check operation, the following items can be checked:

- Currently connected I/O units
- Currently malfunctioning I/O units (connection section)

<Communication Check Procedure>

- (1) Press the [COMMUNICATION CHECK] button, and the [COMMUNICATION CHECK SETTINGS] window will appear.
- (2) Set [Communication Speed] to either [6] or [12]. Setting the communication speed faster may cause the unit to be easily influenced by noise. Normally, set this speed to 6Mbps.

GLC 100 Series

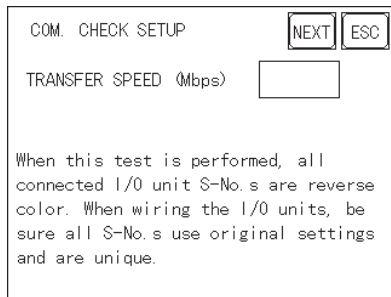

GLC 300 Series/GLC 2400

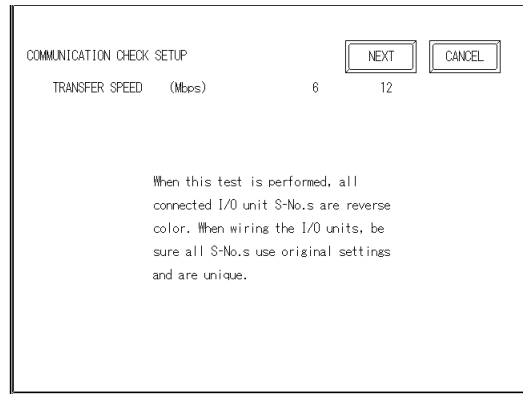

Press the [NEXT] button, and the [COMMUNICATION CHECK] window will appear.

GLC 100 Series

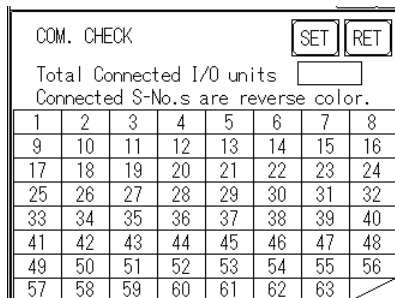

GLC 300 Series/GLC 2400

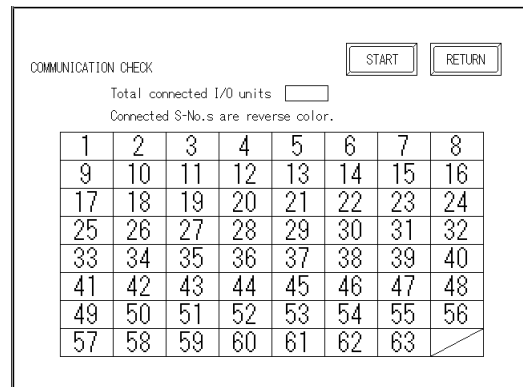

Press the [START] button to begin the communication check.

The currently connected I/O unit's S-No. will be displayed in reverse color.

To return to the [FLEX NETWORK MENU] window, press the [RET] button.

<To select Error S-No. Display>

When a code No. 841 error occurs while the logic program is being executed, the S-Nos. of the I/O units that have been excluded from the communication circuit and malfunctioning I/O units will be checked.

▼Reference▲ 7.4 Flex Network I/F Unit Troubleshooting.

Touch the [CONTROLLER MENU] window's [FLEX NETWORK DRIVER] selection, and the [FLEX NETWORK DRIVER MENU] will appear.

Press the [FLEX NETWORK DRIVER MENU]'s [ERROR S-NO. DISPLAY], the [ERROR S-NO. DISPLAY] window will appear and the error check will begin.

The currently connected I/O unit's S-No.s will appear, and the I/O unit S-No. with the error will be shown in reverse color.

GLC 100 Series

ERR S-No. DISPLAY										RET
Error S-No.s are reverse color.										

GLC 300 Series/GLC 2400

ERR S-No. DISPLAY										RETURN
Error S-No.s are reverse color.										

7.3.2 I/O Monitor (I/O Connection Check)

- (1) Select the [CONTROLLER MENU] window's [FLEX NETWORK DRIVER], and the [FLEX NETWORK DRIVER MENU] will appear.
- (2) Select the [FLEX NETWORK DRIVER MENU] window's [I/O MONITOR], and the following [I/O MONITOR SETUP] window will appear.

◆ **I/O Monitor Settings (when [VARIABLE TYPE] is set to [DISCRETE]):**

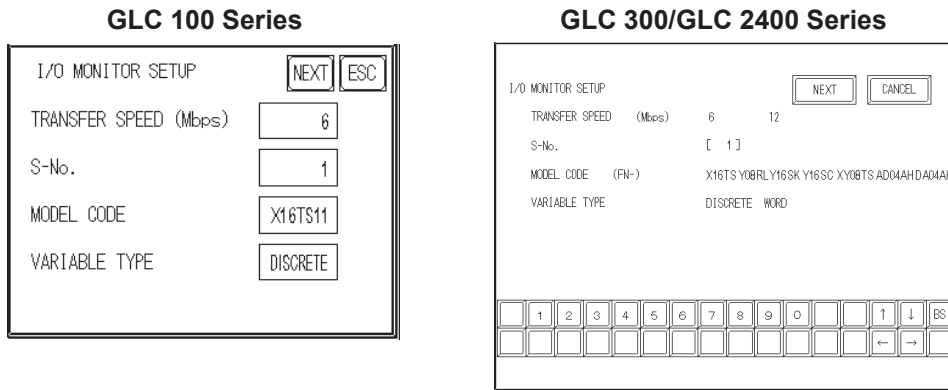

- **Communication speed**

Set [TRANSFER SPEED] to either [6] or [12] mbps. Setting the communication speed faster may cause the unit to be easily influenced by noise. Normally, set this speed to 6Mbps.

- **S-No. (Station no.)**

Select [S-No.] from 1 to 63.

- **Model**

Select from “FN-X16TS”, “FN-XY08TS”, “FN-Y08RL”, “FN-Y16SK”, “FN-Y16SC”, “FN-AD04AH”, and “FN-DA04AH”.

- **Variable type**

Select [VARIABLE TYPE] from [DISCRETE] and [WORD].

* Only the [Word] setting can be used for “FN-AD04AH” and “FN-DA04AH”.

- (3) Press the [NEXT] button, and the following [I/O MONITOR] window will appear.

This window's items will vary depending on the selected [VARIABLE TYPE].

<FN-X16TS/FN-XY08TS/FN-Y08RL/FN-Y16SK/FN-Y16SC>

◆ I/O Monitor (when [VARIABLE TYPE] is set to [DISCRETE]):

The INPUT area terminal numbers where data has been entered will appear in reverse color. Touching an Output area terminal number will output the data and reverse that number's color.

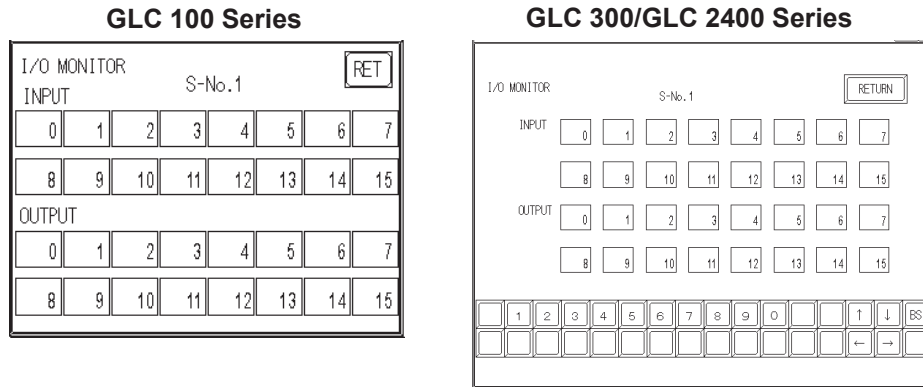

The windows shown above display the maximum input/output points of an I/O unit in the Flex Network system. The number of input/output points will vary depending on each I/O unit model. Use each unit within the range of its I/O points, beginning from "0".

When using an input-only I/O unit, use only input area of the window, and when using an output-only I/O unit, use only the output area. When using a unit with inputs and outputs, use both the input and output area.

◆ I/O Monitor (when the [VARIABLE TYPE] is set to [WORD]):

The input data will be displayed in the input section, if any. Enter the necessary data in the output section via the ten-key pad. When using the GLC100 Series, touch the data display position, and a ten-keypad will appear. After entering data, press the [OUT] button to output the data. Data will be displayed in the decimal system.

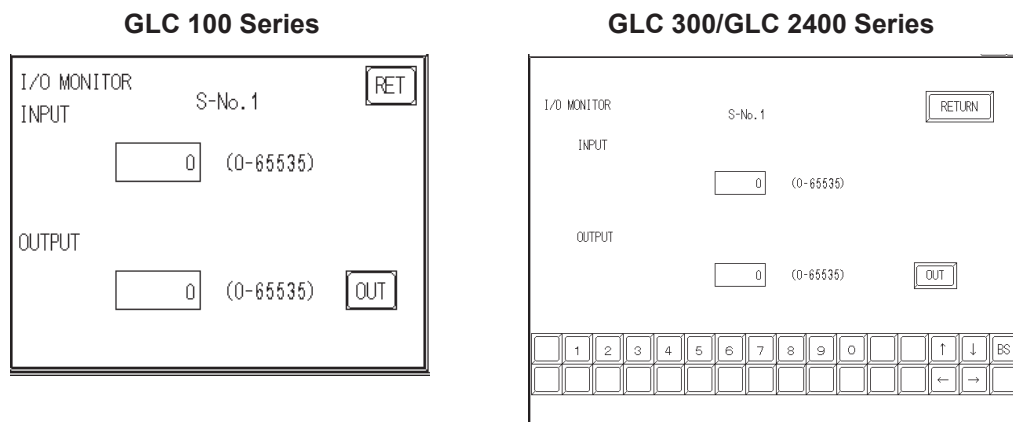



Enter data within the output range, according to the number of the I/O points in each I/O unit.

I/O Points	I/O Range
8	0 to 255
16	0 to 65535

Data will be output to the I/O unit for the number of I/O points according to the [MODEL] selected on the [I/O MONITOR SETUP] window.

<Output Example>

If data that cannot be expressed in the 8-bit system is entered in an 8-point output I/O unit, excess data will be ignored.

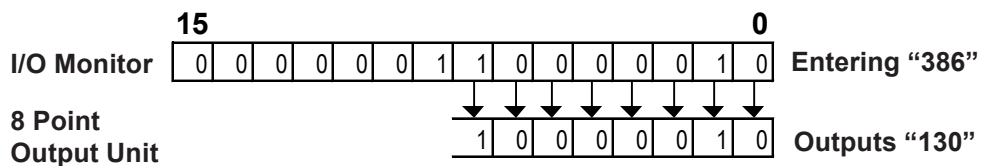

<For FN-AD04AH/FN-DA04AH>

◆ I/O Monitor (Channel setting):

The system switches successively through successively through the selectable settings when the channel area is pressed.

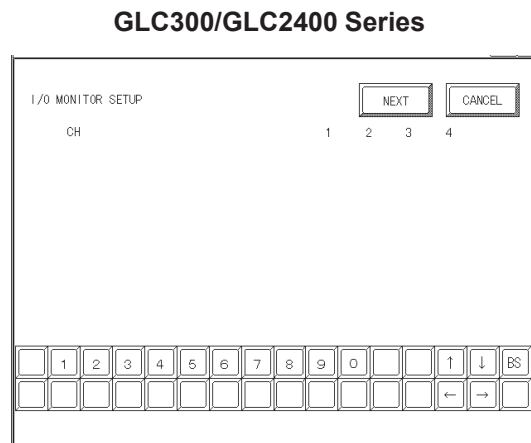
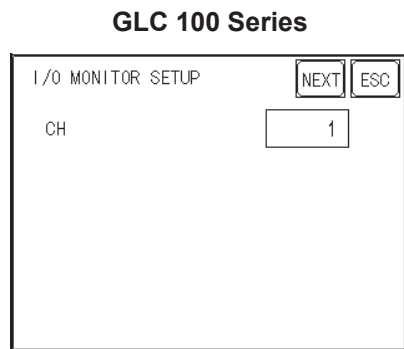

When the [NEXT] button is pressed, the system switches to the next [I/O MONITOR] screen. The screen is different for FN-AD04AH and FN-DA04AH.

<For FN-AD04AH>

◆ I/O Monitor

This displays input data.

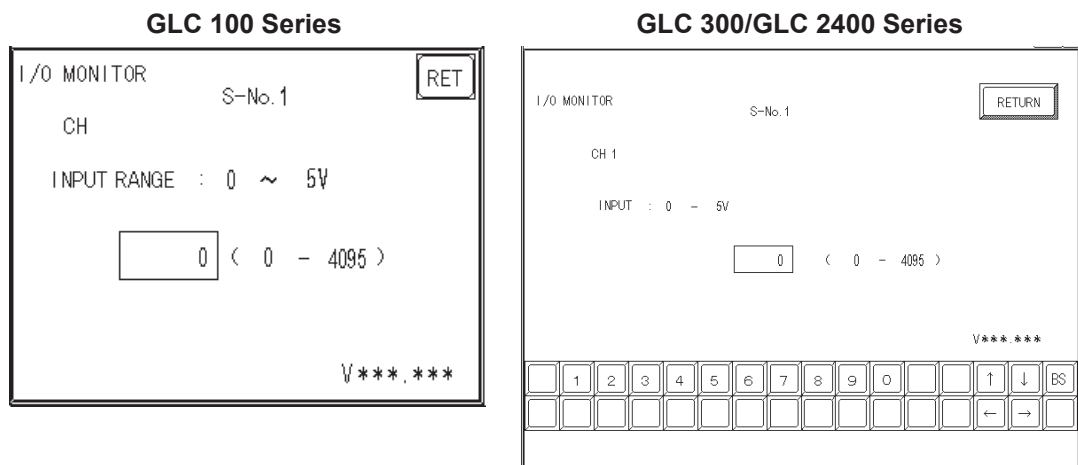

Pressing the [RET(URN)] button returns control to the [I/O MONITOR] screen.

A/D Conversion Table

Input range setting	Input range
0 ~ 5V	0 ~ 4095
1 ~ 5V	0 ~ 4095
0 ~ 10V	0 ~ 4095
-5 ~ 5V	-2048 ~ 2047
-10 ~ 10V	-2048 ~ 2047
0 ~ 20mA	0 ~ 4095
4 ~ 20mA	0 ~ 4095



Settings other than maximum/minimum, A/D conversion sample count and the file type operate with the set content stored on the I/O unit side. To change the set content saved on the I/O unit side, change the set content from the Pro-Control Editor, and download the logic program to the GLC. After that, run the logic program, and the settings will become effective.

<For FN-DA04AH>

◆ I/O Monitor

Enter data with the keypad. With the GLC100 unit, touching the screen's data display will call up the keypad. After entering all data, push the [OUT] button to output the data. All data is displayed in decimal'.

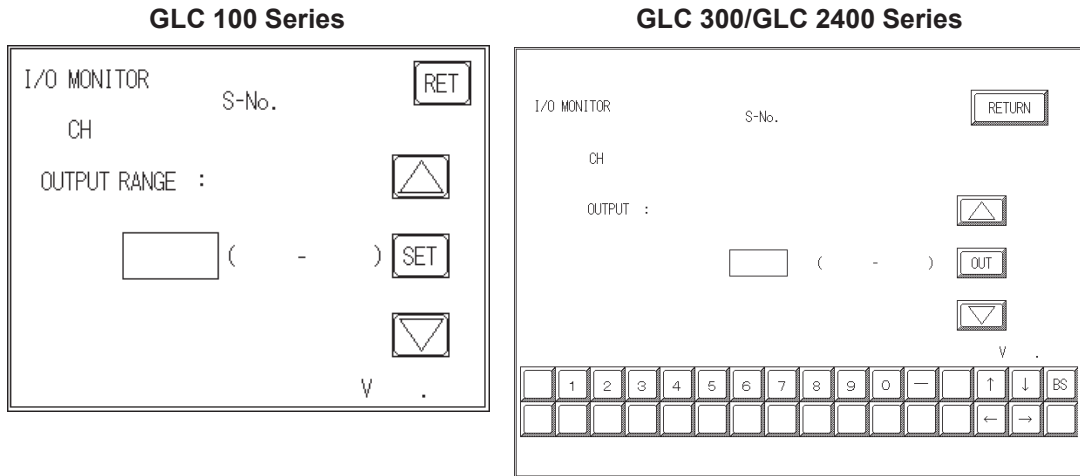

- **Touch the up and down arrow to increase/decrease the range value. Each time the value is changed, the new value is output to the I/O unit.**
- **Pressing the [RET(URN)] button will clear the current data, even if the output hold setting in the I/O unit is ON.**

D/A Conversion Table

Input range setting	Input range
0 ~ 5V	0 ~ 4095
1 ~ 5V	0 ~ 4095
0 ~ 10V	0 ~ 4095
-5 ~ 5V	-2048 ~ 2047
-10 ~ 10V	-2048 ~ 2047
0 ~ 20mA	0 ~ 4095
4 ~ 20mA	0 ~ 4095

7.3.3 Troubleshooting

The following explanation explains possible problems that may occur when using the Flex Network I/F unit, and their solutions.

■ Flex Network I/F unit I/O Errors

For a detailed explanation of Uniwire unit I/O errors, please refer to the Flex Network unit's Users Manual.

■ Error Codes

I/O errors include those occurring during writing and reading. When one of these errors occurs, the controller writes an error code to #IOStatus.

◆ Setting Errors

Error Code	Contents	Solution
501	Internal variable error mapped to I/O terminal.	Reset the variable used.
502	External variable error mapped to I/O terminal.	
503	Output variable error mapped to I/O terminal.	
504	Discrete variable error mapped to analog terminal.	
505	Integer variable error mapped to discrete terminal.	
506	Variable type not supported by driver.	Correct the variable type.
801	Terminal numbers are duplicated.	2 or more terminals are using the same terminal number, possibly causing transfer failure. Download the WLL file again.
802	Multiple S-No. exist.	2 or more areas are using the same area number, possibly causing transfer failure. Download the WLL file again.
803	S-No. is outside of accepted range.	When the number of transfer points is 128, use 0 to 7F for the Input Area. When 256 points are used, use 0 to FF for this area. Check that all settings are within their respective ranges.
804	S-No. range overlap at the analog unit.	Two or more I/O units are using the same S-No. The analog unit has S-Nos. for 4 stations. Reset so there is no S-No. overlap.

◆ Initialization Errors

Error Code	Contents	Solution
821	There is no Flex Network unit attached.	The ID number read from the Flex Network unit is not correct. Occurs when the unit is not attached.
822	Initial Error. Initialization failed to synchronize the Flex Network I/F unit and the unit's driver.	A hardware error may have occurred. For details, refer to the Flex Network unit's Users Manual.
823	Analog unit setting error	Check to see if communication line is disconnected, power is not supplied to the I/O unit, or the I/O unit is malfunctioning.

◆ Run Time Errors

Error Code	Contents	Solution
841	There is an I/O unit error. (loose connector, malfunction, etc.)	Check all related wiring. Reference Flex Network User Guide
842	Disconnected output signal line of sensor for input to the analog unit (A/D conversion unit)	This is likely due to disconnection in the output signal line. Check the output signal line of the sensor.

◆ Internal Errors

Error Code	Contents	Solution
850 ⋮ 859	Driver Error. A major system error has occurred.	Reset the GLC. If an error code still appears, try to identify if the error is due to the GLC itself, or to a related/connected device. Write down the error code and refer to your GLC Users Manual.

8

Error Messages

8.1

Error Message List

This chapter explains the error messages that can appear on the GLC unit. The error messages explained here are those related to the Pro-Control program only.

For further information concerning GLC error messages, refer to

Reference *GLC Series User's Manual* (Sold separately)

Error Message	Cause	Solution
"Invalid ladder file"	The GLC's WLL file is damaged.	Download another copy of the WLL file from the Pro-Control Editor.
"Fatal Error: Drive check Failed"	The GLC's current I/O driver is incorrect.	Check that the I/O driver designated in the WLL file and the driver installed in the GLC are the same.
"Global Data Area Too Small"	The downloaded file's data may be damaged.	Download the WLL file again. If this does not fix the problem, contact your local Proface dealer.
"Can't Set Priority"	The GLC's system file is incorrect. The file may have been damaged during downloading.	Check the the GP Type set in the original screen creation software file is "GLC" and re-transmit the file.
"Exception nnn:[mmm:ooo]"	A fatal error has occurred in the ladder logic program.	Write down the error message details and consult your local Proface dealer.
"Watchdog Error"	The Constant Scan Time is longer than the Watchdog time.	Reset the Watchdog time so that it is longer than the Constant Scan Time. If doing so exceeds the Watchdog Timer's limit, then the Constant Scan Time (program) should be changed.

Chapter 8 - Errors

Error Message	Cause	Solution
"Bad Var: xxx"	Unable to find variable "XXX". Either the WLL file has not been downloaded, or the screen creation software is using a variable that does not exist in the WLL file.	Try either of the following: -Download the WLL file again. -Download the original screen creation software's project file again.
"Bad Array: xxx"	The number of elements used in the screen creation software's array variables and those used in the WLL file's array variables are different.	After re-importing the WLL file's data to the screen creation software, download the WLL file and the project file again to the GLC.
"Bad T type xxx"	The GLC variable "XXX"'s type is different from the screen creation software's variable type.	Either download the WLL file again, or re-import the variables to the project file, then download the project file to the GLC again.
"Unknown register type"	This variable type does not exist.	After re-importing the variables to the screen creation software's project file, download both the WLL and the project file to the GLC again.
"Register is missing"	Cannot find variable used for Writing.	
"S100 file index is out of range"	Cannot find variable used for Reading.	
"Too many entries in the S100 file"	Too many variables are being used. Limit is 2048.	
"S100 file is missing"	Cannot find S100 (variable storage file).	
"Over Compile count MAX"	Too many Tags or Parts are being used.	
"Logic Program is Empty"	WLL file has not been downloaded to the GLC, or the WLL file in the GLC (FEPR0M) is damaged. (GLC2400 only)	Download WLL file again from Pro-Control Editor.
"No backup logic program in FEPR0M"	WLL file has not been copied to FEPR0M after online editing. This message is a warning message. (GLC2400 only)	Copy WLL file to FEPR0M using GLC offline menu.
"SRAM checksum error"	WLL file stored in SRAM is damaged. (GLC2400 only)	Download WLL file again from Pro-Control Editor.
"SRAM data broken"	The battery for SRAM back-up may have run out. This message is a warning message. (GLC2400 only)	Execute from the WLL file in FEPR0M. Using online edit, check that no changes have been made in the logic program.
"Exception 65532 [xxxx : xxx]" "Exception 65533 [xxxx : xxx]" "Exception 65534 [xxxx : xxx]" "Exception 65535 [xxxx : xxx]"	GLC heap memory is insufficient. Memory for storing programs and variables is sufficient, however logic program memory is insufficient.	Setup the GLC unit again with GP-Pro/PB III after reducing the logic program size, or the number of variables and labels. Also reduce the number of array variable elements, or shorten the name of variables and labels.

8.2 Error Codes

The following table shows about the error of #FaultCode written in when errors occur.

Error Code	Level	Cause
0	Normal	No errors
1	Minor	The calculation result, or the result of the conversion of a Real variable to an Integer variable has resulted in an overflow.
2	Major	A reference was used for an area outside the array's range.
3	Major	A reference was used for a bit outside the Integer's (32 bit) range
4	Major	The stack has overflowed.
5	Major	Incorrect command code is being used.
6	-	Reserved for System.
7	Major	The Scan time is now longer than the Watchdog time.
8	Major	Reserved for System.
9	Major	Software Error. Depending on type of problem, system may need to be restarted.
10	-	Reserved for System.
11	-	Reserved for System.
12	Minor	BCD/BIN Conversion Error
13	-	Reserved for System.
14	-	Reserved for System.

8.3 Program Errors

The following table explains the Pro-Control Editor's program operation errors.

Error Type	Possible Problem	Solution
Control Memory power is cut	Battery Alarm	Exchange Unit
Keep Area data is not preserved	Memory Alarm	Exchange Unit
Program Malfunction	Program transfer mistake. Keep area in memory should store the program. The program has not been transferred to the Execute area.	Use Pro-Control Editor to restart the control feature. ▶ Reference ◀ refer to the Pro-Control Editor Operation manual
	When output data performs RUN/STOP switchover, Keep Clear control feature becomes enabled.	Turn off the control feature.
Soon after entering RUN mode unit changes to STOP mode	A Command Execution Alarm has occurred. Or, a major fault has occurred.	Modify the program. Check the contents of the #FaultCode data. Also check if the System variable #Command has been written to.
Pro-Control Editor cannot enter Monitoring mode	The data transfer cable used to send data from the screen creation software to the GLC unit may be loose or disconnected. Also, the PC or GLC's power may have dropped, causing excessive noise and possibly destroying the content	Please contact your local GLC distributor for assistance.
WLL files cannot be downloaded from Pro-Control Editor		
The project (.prw) file cannot be downloaded from the screen creation software.		

Index

A

Accessing a Discrete Array 3-3
Accessing a Real Array 3-3
Accessing an Integer/Integer Array 3-3
APPLICABLE PRODUCTS 2
Applicable Software 3
Applicable Units 3
Arithmetic Operation Commands 5-3

B

Bit Operation Commands 5-1
Bus Conversion Unit 1-5

C

Constant Scan Time Mode 2-4
Controller's current condition 4-1
Convert Commands 5-4
copyrights 1

D

DIO Unit 7-2
DIO Unit Input Errors 7-5
DIO Unit Output Errors 7-5
Direct Access Method 6-3, 6-5
Direct PLC Connection 1-3
Discrete 3-1
Discrete Variables 3-1
Disk Media Usage Precautions 7

E

Error Codes 7-7, 7-9, 8-3
Error Message List 8-1

F

First Scan 2-3
foreign regulations 1

G

General Information Symbols and Terms 7
GLC and PLC Data Sharing 6-5
GLC Series Expansion Units 1-5
GLC Users Manual 1-1
GP Screen Data Transfer Cable 1-5
GP-PRO/PBIII for Windows Operation Manual 1-1

I

I/O Drivers 7-1
I/O error 7-1
ID (Terminal numbers) data 7-9
Initial Processing 2-3
Initial Settings 1-3
Initialization Errors 7-7, 7-10

installation information 1-1
Integer 3-1
Integer Variables 3-1
intellectual properties 1
Internal Errors 7-7, 7-10

L

L/S Area Refresh Feature 6-1
limitations 3-3
Loading 2-3
local distributor 7
Logic Program 1-1
logic program development 1-1
Loopback Cable Creation 7-3
LS Area 1-7
LS Area Refresh Cautions 6-6

M

Mathematical Commands 5-3
Memory Link Method 6-3, 6-4
Memory Link method 1-5
Mitsubishi Electric 1-1, 1-3, 1-5, 2-4
Movement Commands 5-3

O

OFFLINE menu 7-9

P

peripheral device 1-3
PLC specifications 1-7
PLC-GP Connection 1-1, 4-2
PLC's Data Read Area 1-7
PREFACE 1, 7
Preparation 1-1
Pro-Control Editor Operation Manual 1-1
Pro-Control Editor Ver 1.5 3
Program Errors 8-4

R

Readme.txt 1
Real 3-1
Real Variables 3-1
registered trademarks 2
RS-422 Connector Terminal Block 1-5
Run Time Errors 7-7, 7-10
Running 2-3

S

Safety Symbols and Terms 7
Scan Time Adjustment 2-4
Setting Errors 7-7, 7-9

Index

SIZING button 7-9
Stand-Alone System 1-3
STOP 2-3
System Variable List 4-1

T

Temporary Stop 2-3
Timer and Counter Commands 5-3
Tool connector 1-5
TRADEMARK RIGHTS 3

U

Uniwire I/F unit I/O Errors 7-9

V

Variable Names 3-3
variable storage area 3-1