Panel-Cut Conversion Attachment Brackets (PL-69X0 Series) Installation Guide

This guide covers the following product.

- APL3600-ATP69X0-01

This conversion attachment brackets are used to install the PL-3600T series to the panel cut hole for installing the PL-6900/6920/6930 series.

Corresponding models: PL-3600T series (hereafter referred as the "PL")

About the Manual

For the detailed information on the PL, refer to the following manuals.

- PL3000 Series Hardware Manual

Manuals for PL3000 series can be downloaded from Pro-face Home Page.

URL

<http://www.pro-face.com/otasuke/>

Safety Cautions



Installation

- When installing the brackets to the PL, be sure to read this guide completely to insure that the brackets are correctly installed.
- Use the provided mounting screws only and tighten them with proper torque. The PL may drop out of the panel.
- Do not drop and damage the brackets. Using the deformed brackets may cause the PL's drop out of the panel.

Precaution at disposal

- When the brackets are disposed of, it should be done so according to your country's regulations for similar types of industrial wastes.

Package Contents

- (1) Conversion Attachment Brackets (2)
(APL3600-ATP69X0-01)

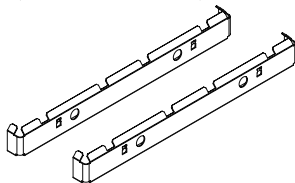

- (2) M3 x 6 mounting screws (8)
(3) Installation Guide (1) <this guide>

Pro-face has taken the utmost care to ensure the quality of this product when it was shipped, however, should, for any reason, problems or damage have occurred during shipping, please contact your Pro-face representative immediately for service.

Structure

When installing the PL to the panel with the brackets, the PL does not conform IP65f standards. If conforming to the IP65f standards is required, do not use the brackets.

Vibration Resistance

The vibration resistance of the PL installed to the panel with the brackets is as follows;

Vibration Resistance	Without HDD	IEC/EN61131-2 compliant 5 to 9 Hz single-amplitude 3.5mm [0.14in.] 9 to 150 Hz constant-acceleration 9.8m/s ² X, Y, Z directions for 10 cycle (100 minute)
	With HDD	10 to 57 Hz single-amplitude 0.0375mm [0.0015in.] 57 to 150 Hz constant-acceleration 4.9m/s ² X, Y, Z directions for 10 cycle (100 minute)

Panel Cut Dimension

The brackets are used to install the PL-3600T series to the panel cut hole for installing the PL-6900/6920/6930 series.

The panel cut within the following mounting hole enables to install the PL.

Unit: mm [in.]

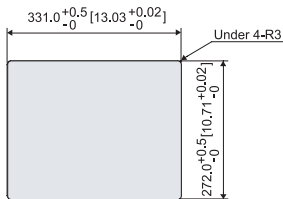

Installation With The Brackets

As shown in the following figure, fix the two brackets to the PL-3600T series with eight screws.

Be sure to use the installation gasket and mount it correctly, then attach the brackets.

Both brackets have no difference so that you can install each bracket to the top or bottom of the PL.

Be careful for directions of installation.

The torque should be 0.5 to 0.6 N·m.

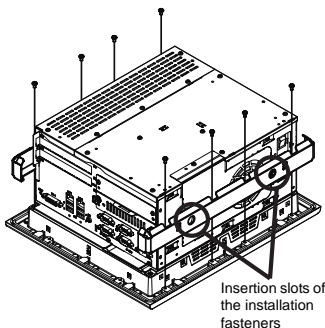

Tight the four provided installation fasteners on the top and bottom of the PL. Be careful for the insertion slots location of the fasteners. The torque required to tighten these screws is 0.8 N·m.

SEE →

"PL3000 Series Hardware Manual"
(Installation)

Inquiry

Do you have any questions or comments about this product? Please access our site anytime you need help with a solution.

<http://www.pro-face.com/otasuke/>

Note

Please be aware that Digital Electronics Corporation shall not be held liable by the user for any damages, losses, or third party claims arising from the uses of this product.

Digital Electronics Corporation

8-2-52 Nanko-higashi

Suminoe-ku, Osaka 559-0031

JAPAN

TEL: +81-(0)6-6613-3116

FAX: +81-(0)6-6613-5888

<http://www.pro-face.com/>

The information in this document is subject to change without notice.

© Copyright 2008 Digital Electronics Corporation. All rights reserved.