

Digital
Human Machine Interface —

Pro-face

**BOX-Type Industrial Computer
PL-B910 Series
User Manual**

When printing out this PDF manual, since the printer setting can effect the quality of the printout, be sure your printer's quality setting is set to "High".

Digital
Digital Electronics Corporation

Introduction

Thank you for purchasing Proface's PL-B910 series Box Type Industrial Computer, hereafter referred to as "the PL". This unit embodies Proface's latest, cost-effective architecture and is designed for Industrial Automation users.

Prior to using your PL, be sure to read this manual thoroughly to familiarize yourself with the unit's operation procedures and functions.

NOTE:

1. It is forbidden to copy the contents of this manual in whole, or in part, without the permission of the Digital Electronics Corporation.
2. The information in this manual is subject to change without notice.
3. This manual was written with care; however, if you should find any errors or omissions, please contact Digital and inform them of your findings.
- 4) Please be aware that Digital Electronics Corporation shall not be held liable by the user for any damages, losses, or third party claims arising from the uses of this product.

© Copyright 2001 Digital Electronics Corporation

MS-DOS®, Windows® 95, Windows® 98 Second Edition and Windows NT® are registered trademarks of the Microsoft Corporation.

IBM®, and DOS® are registered trademarks of IBM.

Product names used in this manual are the trademarks of their respective manufacturers.

Essential Safety Precautions

This manual includes the following cautions concerning procedures that must be followed to operate the PL correctly and safely. Prior to operating the PL, be sure to read this manual and any related materials thoroughly to understand the correct operation and functions of this unit.

Safety Icons

To allow you to use the PL correctly, throughout this manual, the following icons are provided next to operations requiring special attention. These icons are used to describe the following situations:



Indicates situations where severe bodily injury, death or major equipment damage may occur.



Indicates situations where slight bodily injury or machine damage can occur.

WARNINGS

- To avoid the possibility of an electric shock, be sure to connect the power cord to the PL before connecting it to the main power supply.
- A fire or electrical shock may occur if voltages used with the PL are beyond the specified range. Be sure to use only the specified voltage.
- Before opening the PL's protective cover, be sure to turn the unit's power OFF. This is because the PL's internal parts carry high voltages.
- To avoid fires or electrical hazards, do not modify the PL in any way.
- If metal particles, water or other types of liquids contact any of the PL's internal parts, immediately turn the unit's power OFF, unplug the power cord, and contact either your PL distributor or the Digital Electronics Corporation.
- Read and understand Chapter 4 "Installation and Wiring" thoroughly in order to select an appropriate installation location for the PL.
- Before either plugging in or unplugging a board or interface connector, be sure to turn the PL's power OFF.



WARNINGS

- To prevent a possible explosion, do not install the PL in areas containing flammable gases.
- The PL is not appropriate for use with aircraft control devices, aerospace equipment, central trunk data transmission (communication) devices, nuclear power control devices, or medical life support equipment, due to these devices' inherent requirements of extremely high levels of safety and reliability.
- When using the PL with transportation vehicles (trains, cars and ships), disaster and crime prevention devices, various types of safety equipment, non-life support related medical devices, etc. redundant and/or failsafe system designs should be used to ensure the proper degree of reliability and safety.



CAUTIONS

- Avoid exposing the PL to, or operating the PL in direct sunlight, high temperatures and humidity, and in areas where excessive dust and vibration will occur.
- Avoid using the PL in areas where sudden, extreme changes in temperature can occur. This may cause condensation to form inside the unit, possibly leading to an accident.
- To prevent the PL from overheating, be sure its air circulation vents are clear and clean, and keep the unit's operation area well-ventilated.
- Avoid operating or storing the PL near chemicals, or where chemicals can come into contact with the unit.
- When the Standard display is connected to the PL, after turning the display OFF, be sure to wait at least three (3) seconds before turning it ON again.

When PL Hard Disk (HDD) data is lost:

- The Digital Electronics Corporation cannot be held responsible or provide any compensation for damage(s) caused by the loss of data stored in the PL's hard disk drive (HDD). It is therefore strongly suggested that all important data and software be backed up regularly to an external data backup device.
- Please be aware that the Digital Electronics Corporation bears no responsibility for any damages resulting from the customer's application of this unit's hardware or software.
- Since the PL unit's hard disk drive (HDD) is a consumable item, i.e. it has a limited lifetime, be sure to back up its data regularly and prepare a spare HDD unit.
- To prevent file data damage, be sure to shut down the PL's OS before turning OFF the main power.
- After turning OFF the PL's power, wait until the internal HDD stops spinning before turning on the power again (approx. 5 seconds).
- When the PL unit's standard display is connected to the PL using the USB cable, wait three (3) seconds before turning the power ON again.

Table of Contents

Introduction	1
Essential Safety Precautions	2
Table of Contents	5
Documentation Conventions	8
PL Series Model Numbers	8
Package Contents	9
Special Features	10
UL/c-UL(CSA) Application Notes	11
CE Marking Notes	11

CHAPTER 1 PL BASICS

1.1 Prior to Operating the PL	1-1
1.1.1 Touch Panel Connection	1-3
1.1.2 Connecting the Dual Displays	1-4
1.2 PL System Configuration	1-6
1.3 Optional Items	1-7

CHAPTER 2 SPECIFICATIONS

2.1 General Specifications	2-1
2.1.1 Electrical	2-1
2.1.2 Structural	2-1
2.1.3 Environmental	2-2
2.2 Functional Specifications	2-3
2.2.1 General	2-3
2.2.2 Expansion Slots	2-4
2.2.3 Clock (RTC) Accuracy	2-4
2.3 Interface Specifications	2-5
2.3.1 Keyboard Interface	2-5
2.3.2 Mouse Interface	2-5
2.3.3 CRT Interface	2-5
2.3.4 RS-232C Interface (COM1/COM2/COM3)	2-6
2.3.5 Printer Interface (LPT1)	2-6
2.3.6 RAS Interface	2-7
2.3.7 USB Interface (USB)	2-8

Preface

2.4	PL Part Names and Features	2-9
2.5	PL External Dimensions	2-12
2.5.1	PL-B900/B910 Series External Dimensions	2-12
2.5.2	Installation Fasteners	2-14
2.5.3	Full-Sized Cover/Mirror Disk Unit Attachment Dimensions...	2-16

CHAPTER 3 INSTALLING OPTIONAL UNITS AND EXPANSION BOARDS

3.1	Installation	3-1
3.1.1	Removing the Rear Maintenance Cover	3-2
3.1.2	Installing the DIM Module (PL-EM220 / PL-EM230)	3-4
3.1.3	Installing the FDD Unit (PL-FD200)	3-5
3.1.4	Installing the FDD Unit (PL-FD210)	3-6
3.1.5	Removing/ Installing the HDD Unit (PL-HD220)	3-8
3.1.6	Installing an Expansion Board	3- 9
3.1.7	Connecting the CD-ROM Unit (PL-DK200)	3-10
3.1.8	Attaching the Display Expansion Board (PL-PE200)	3-11
3.1.9	Connecting the Standard Display (DU-6900/DU-7900)	3-12
3.1.10	Connecting an Analog RGB Monitor	3-13
3.1.11	Removing the Cooling Fan Unit	3-5

CHAPTER 4 INSTALLATION AND WIRING

4.1	Installation Cautions	4-1
4.2	Installing the PL	4-3
4.2.1	Installation Procedures	4-3
4.3	Wiring the PL	4-4
4.3.1	Connecting the Power Cord	4-4
4.3.2	Power Supply Cautions	4-6
4.3.3	Grounding Cautions	4-7
4.3.4	Cautions When Connecting I/O Signal Lines	4-7

CHAPTER 5 SYSTEM SETUP

5.1	Setup Procedures.....	5-1
5.2	System Parameters.....	5-2
5.2.1	STANDARD CMOS SETUP	5-2
5.2.2	BIOS FEATURES SETUP	5-4
5.2.3	CHIPSET FEATURES SETUP	5-6
5.2.4	POWER MANAGEMENT SETUP	5-8
5.2.5	PNP/PCI CONFIGURATION SETUP	5-10
5.2.6	LOAD BIOS DEFAULTS	5- 2

5.2.7	LOAD SETUP DEFAULTS	5-12
5.2.8	SYSTEM MONITOR UTILITY	5-12
5.2.9	INTEGRATED PERIPHERALS	5-14
5.2.10	IDE HDD AUTO DETECTION	5-17

CHAPTER 6 OS SETUP

6.1	Setting Up Your PL OS	6-1
6.1.1	Touch Panel Device Driver Settings	6-2

CHAPTER 7 MAINTENANCE AND INSPECTION

7.1	Cleaning the Filter	7-1
7.2	Periodic Maintenance Points.....	7-3



APPENDICES

A.1	Hardware Configuration	6-1
A.1.1	I/O Map	6-1
A.1.2	Memory Map	6-2
A.1.3	Interrupt Map	6-3
A.2	RAS Feature	6-4
A.2.1	PL's RAS Features	6-4
A.2.2	RAS Feature Details	6-5
A.2.3	RAS Feature Overview	6-9

INDEX

Documentation Conventions

The list below describes the documentation conventions used in this manual.

Symbol	Meaning
 <i>Important</i>	Indicates important information or procedures that must be followed for correct and risk-free software/device operation.
 Note:	Provides useful or important supplemental information.
*1	Indicates useful or important supplemental information.
 Reference	Refers to useful or important supplemental information
1) , 2)	Indicates steps in a procedure. Be sure to perform these steps in the order given.
PL	Abbreviation for the PL-B910 Series Box Type Industrial Computers.
DU	Standard display unit for the PL-B910 Series Box Type Industrial Computers.

PL Series Model Numbers

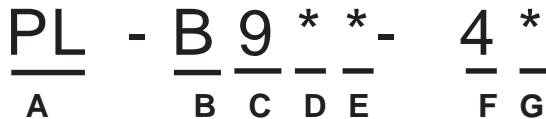

Item	Code	Meaning
A	PL	PL Series Panel Computer
B	B	"Box" type industrial computer
C	9	PL-X900 Series unit
D	0	PL-B910 Series unit (Single display type)
	1	PL-B910 Series unit (Dual display type)
E	0	4-Slot type*1
	1	2-Slot type *1
F	4	CE Marking, UL/c-UL(CSA) Approval
G	*	PL unit's revision number

*1 Refers to the number of available ISA Bus expansion slots.

Package Contents

The PL's packing box contains the items listed below. Please check to confirm that all items shown below have been included.

■ **PL Unit**

PL-B900 Series
PL-B910 Series

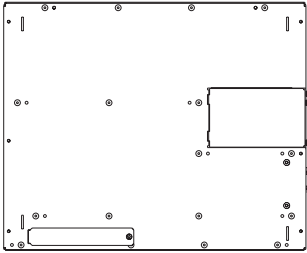

■ **Power Cord**

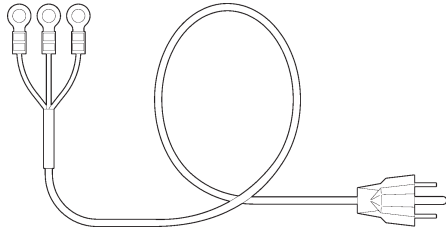

Be careful when handling the PL not to damage the built-in HDD



This cord is designed only for AC100/115V use. Any other voltage will require a different cord.

- **CD-ROM (1)**
Contains Box Type Industrial Computer PL-B910 Series User Manual (This manual)



- **PL-B910 Series Box Type Industrial Computer Instruction Guide**
(English 1/Japanese 1)



- **Installation Brackets**
(2 brackets - left and right)
(6 attachment screws)

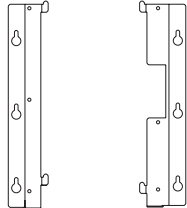

- **Floppy Disks (3)**
(PLX900 Series Driver and Utility Disks)

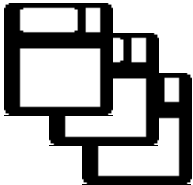

- **Floppy Disks (3)**
(PL-B910 Series Driver and Utility Disks)

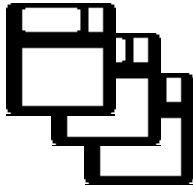

- **Floppy Disks (2)**
(PL-B910 Series USB Touch Panel Control Utility Disks)



If your PL contains a built-in HDD

Your PL unit package will also contain an Installation Guide for your built-in HDD unit. Be sure to check that guide's package contents.

Special Features

The PL series units are equipped with the following unique features:

■ The Latest, High-Performance Architecture

Designed around the AMD-K6[®]-2 333MHz CPU, the PL utilizes the type of high performance IBM compatible architecture that offers you superior performance. This allows you to easily use the popular Windows[®] 95, Windows[®] 98 Second Edition, Windows[®] NT operating systems, as well as others.

However, the software contained in the accompanying [Driver and Utility Disk] is designed specifically for use with only Windows[®] type OS. If this software is used with other OS types, its performance cannot be guaranteed.

▼Reference▲ For further information, refer to **6.1 Setting Up Your PL OS**

■ Highly Expandable

Choose from the PL-B911 series unit - with 2 ISA slots, or the PL-B910 series unit - with 4 ISA slots. In addition, the PL-B901/PL-B911 unit provides a single PCI bus (slot 2), while the PL-B910 unit provides two PCI buses (slots 2 and 3). Also, these slots can accommodate both Digital's own optional boards as well as other commercially available expansion boards.

Digital also offers a wide variety of optional products, such as a -5/-12V DC power unit, DIM memory modules, etc.

■ Separately Designed Main Unit and Display

The PL's separated main unit and display offer you an expanded range of installation options for all your applications.

■ Special Design Digital Video Interface

The PL's unique state-of-the-art digital video interface dramatically reduces LCD display flickering.

■ Single Cable for Video and Touch Panel Signals

This all-in-one cable allows you to easily connect the PL's display and main units together.

■ Dual Display Feature

When the Display Expansion Board is installed in a single PL, two display units can be connected.

■ Dual Touch Panel Feature

In order to prevent the accidental misoperation of two simultaneously connected display units, a special interlock feature is used. This interlock feature, which is contained in the Interlock program, prevents accidental misoperation without requiring additional programming.

■ USB Interface

This standard type USB interface allows you to easily connect any standard type of USB compatible device.

UL/c-UL(CSA) Application Notes

The PL-B910 Series units are (c)UL 1950 recognized products. (UL File No. E171486). Please pay special attention to the following instructions when applying for UL/c-UL approval for machinery which includes any of these PL units.

Equipment with a PL mounted in it requires UL/c-UL evaluation for the combination of the PL and equipment.

The PL conforms as a component to the following standards:

UL 1950, Third Edition, dated March 1,1998 (Standard for Safety of Information Technology Equipment, including Electrical Business Equipment)

CSA-C22.2 No. 950-M95 (Standard for Safety of Information Technology Equipment, including Electrical Business Equipment)

PL-B910-4* (UL Registration Model: 2780056-02) PL-B911-4* (UL Registration Model: 2780056-01)

- The PL should be used as a built-in component of another product.
- Use the PL indoors only.
- When connecting the PL's power cord, be sure to use a cord that is appropriate for the current and voltage used, and that has conductive wires that are 0.75 mm² or larger.
- When an end-use product will include the PL, be sure to design the PL's power cut-off switch as a separate disconnect device and locate it where the operator can easily reach it.
- Danger of explosion if backup battery is incorrectly replaced. Replaced only with same or equivalent type recommended by the manufacturer. Dispose of used batteries according to the manufacturer's instructions.
- Be sure the unit the PL is built into is a (c)UL1950 approved structure.

CE Marking Notes

The PL-B910 series units are CE marked, EMC compliant products.

<These units comply with the following standards>

■ **Safety**

EN60950

■ **EMI (EN50081-2)**

EN55011 Group1 (Class A)

■ **EMS (EN50082-2)**

EN61000-4-2, EN61000-4-3, EN61000-4-4, EN61000-4-6, EN61000-4-8, ENV50204

If following requirements are not met, the PL may fail to meet EN60950 standard requirements.

- The PL must be used as a built-in component of an end-use product.
- The PL is intended for indoor use only.
- When connecting the PL's power cord, be sure to use a cord that is appropriate for the current and voltage used and that has conductive wires that are 0.75 mm² or larger.
- When installing the PL in a metal panel or cabinet, be sure to place the PL's Power disconnect device (cut-off switch) where the unit's operator can easily reach it.
- There is a danger of explosion if the PL's backup battery is incorrectly replaced. This battery should be replaced only with same or equivalent type recommended by the manufacturer. Dispose of used batteries according to the manufacturer's instructions.
- Be sure the cabinet/enclosure the PL is built into uses an EN60950 approved sheet steel structure.

Memo

Chapter

1 PL Basics

1. Prior to Operating the PL
2. PL System Design
3. Optional Items

1.1 Prior to Operating the PL

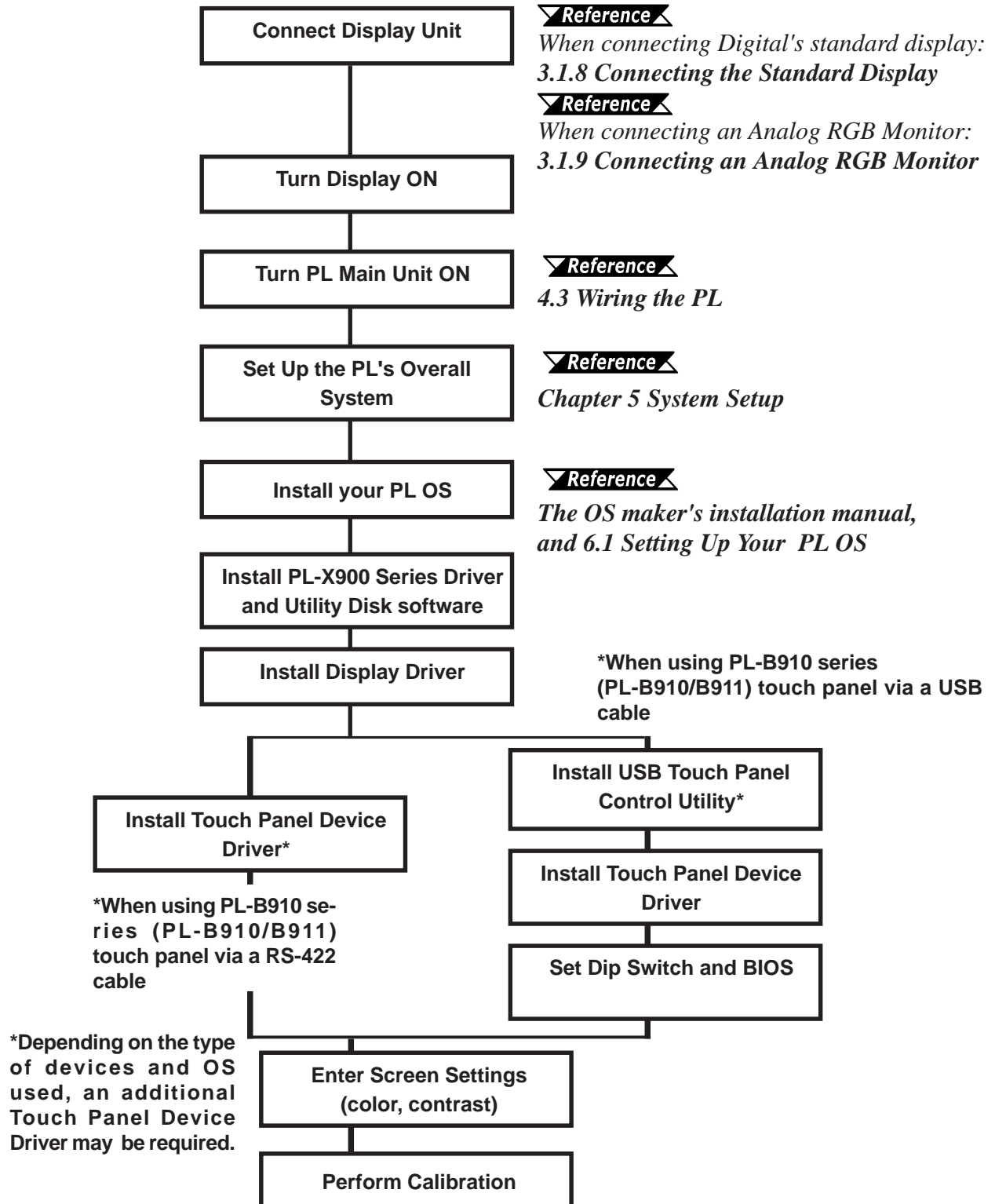



- *After completing the hardware setup, before any data or applications can be placed on the HDD drive, the OS (Windows® or MS DOS®, etc.) must be used to initialize the HDD and create partitions. For details concerning these procedures, refer to the OS maker's installation manual.*
- *After turning the PL OFF, be sure to wait at least 5 seconds before turning it ON again. If the unit is started too soon, it may not start up correctly.*

1.1.1 Touch Panel Connection

You can connect a touch panel using either a RS-422 or a USB cable.

The RS-422 and USB cables have limitations concerning OS type and number of DU units.

Touch Panel Cable	PL Type	OS Type	Display Connection Type
RS-422 Cable	PL-B910 Series	Windows® 95	Single Display
		Windows NT® 4.0	
USB Cable	PL-B910 Series	Windows® 98	Single Display
		Second Edition	Dual Display



- **When a DU is connected via a USB cable, be sure to wait 3 seconds after turning the power OFF before turning it ON again.**
- **Be sure to use only the OS types shown here with each cable. If a different type OS is used, the utility software (drivers, etc.) is not supported.**

■ System Settings

Depending on the touch panel cable used, system settings will change. When the factory settings are for an RS-422 cable. **Reference** Chapter 5 System Setup

■ Dip Switch Settings

Depending on the touch panel cable used, the DU unit's rear face dipswitch settings will change. These settings must also be set on the PL unit's side face dipswitches. The DU unit's factory settings are for an RS-422 cable.

◆ RS-422 Cable Settings (Windows® 95, Windows NT® 4.0)

<PL Settings>

SW No.	1	2	3	4
position	ON	OFF	ON	OFF

<DU Settings>

SW No.	1	2	3	4	5	6	7	8
position	ON	OFF	ON	OFF	OFF	OFF	OFF	ON

◆ USB Cable Settings (Windows® 98 Second Edition)

<PL Settings>

SW No.	1	2	3	4
position	OFF	ON	OFF	ON

<DU Settings>

SW No.	1	2	3	4	5	6	7	8
position	OFF	ON	OFF	ON	Unit Number			OFF



Note: When setting the DU's Station Number, Please see "PL-DU6900/7900 User Manual"

1.1.2 Connecting the Dual Displays

When a USB cable is used, up to 2 DU units can be connected to a single PL unit. Connecting two displays requires two of the optional display cables (PL-CB200-5M) and one Display Expansion Board (PL-PE200). Use the following explanations when connecting the DUs and the Display Expansion Board. The PL-B910/PL-B911(PL-B910 Series) units can use up to 2 DU series displays.

Reference Chapter 3.1.8 Attaching the Display Expansion Board (PL-PE200)

With connecting an RS-422 cable, only one display can be attached to one PL unit. There are two types of installation methods; the Star connection or the Daisy Chain connection.



The performance of any connection method used that is different from those shown below is not guaranteed.

■ Star Connection

With the Star Method, the Display Expansion Board is installed in the PL and both display cables are connected to the PL.

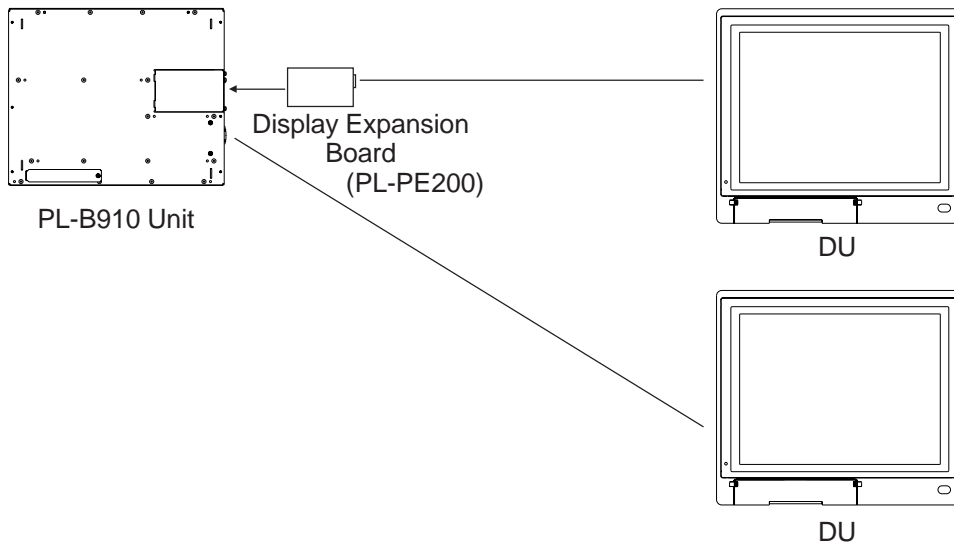

■ Daisy Chain Connection

With this method, the Display Expansion Unit is installed in the first DU unit, and the 2nd DU unit is connected to the first DU unit.

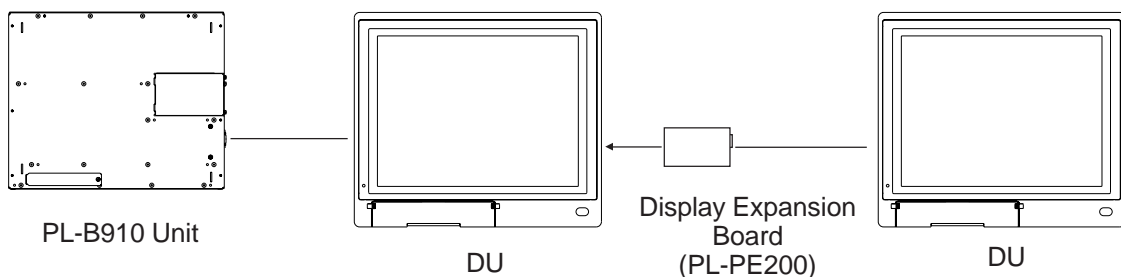

Note: If the first DU unit in the chain is not turned ON, the second DU cannot operate.

When attaching the Dual Displays, be sure of the following points.

- The Touch Panel connection cable should be a USB cable.
- The operating system should be Windows® 98 Second Edition.
- For information about PL and DU unit dip switch settings.

▼Reference▲ 1.1.1 Touch Panel Connections ■Dip Switch Settings

Box Type Industrial Computer PL-B900/B910 Series User Manual

- Be sure the DU units used are the same type(A PL-DU6900-T42 can not be used with a PL-DU7900-T42 unit.).
- Be sure the Station No.s used for each DU unit are different.

▼Reference▲ PL-DU6900/PL-DU7900 User Manual

- Be sure cable used to connect the displays is the PL-CB200-5M.



- **When connecting a display, please use the display cable/5m (PL-CB200-5M). When using a USB cable, the display cable/10m (PL-CB200-10M) can not be used.**
- **To prevent the device's malfunction, please be sure NOT to connect more than 3 DU units per a PL unit.**
- **To prevent accidental touch operation conflicts or misoperation when the Dual Display feature is used, be sure to use the Touch Interlock program included with the PL's utility disks.**

▼Reference▲ Chapter 6 OS Setup

1.2 PL System Configuration

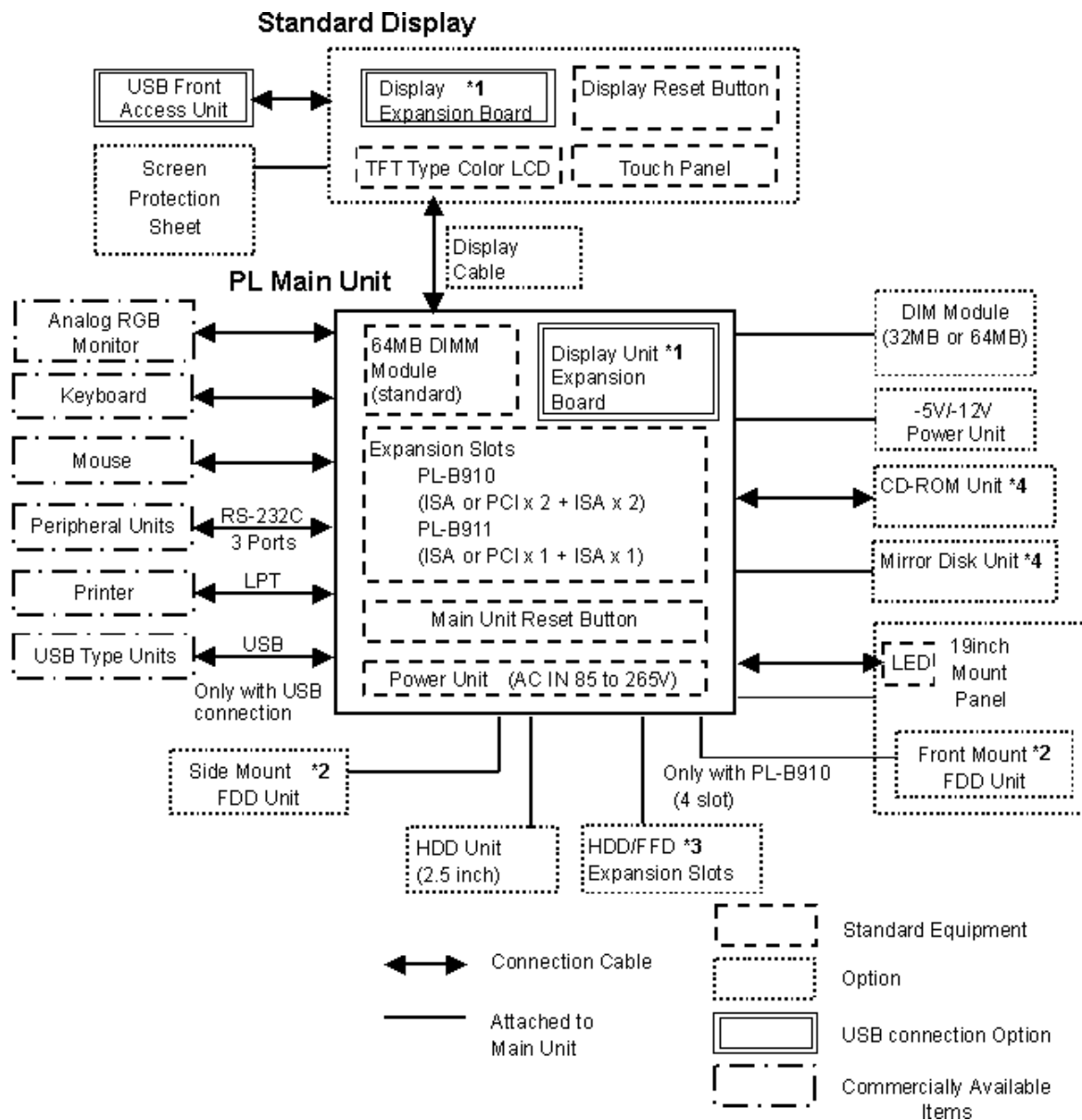

*1 When using the USB connection, the PL-B910/B911 Dual Display requires the Display Expansion board for either the PL or the DU.

*2 The PL-B910 side and front mount FDD units can be used individually, not simultaneously.

*3 Certain limitations exist for the combinations of the HDD unit, the FFD unit, the Mirror Disk unit and the CD-ROM drive. **Reference** 1.3 Optional Items



The above system configuration represents the internal design and peripheral equipment connectable to the PL. The user's actual combination of these items may differ.

1.3 Optional Items

Name	Model number	Description
Standard Display	PL-DU6900-T42	12.1 inch TFT display panel made by the Digital Electronics Corporation. Connects to PL Main Unit.
	PL-DU7900-T42	15 inch TFT display panel made by the Digital Electronics Corporation. Connects to PL Main Unit.
Display Unit Cable	PL-CB200-5M	Connects Standard Display and Main Unit. (5m)
	PL-CB200-10M	Connects Standard Display and Main Unit. (10m) (Used only with RS-422 connection)
DIM Module	PL-EM220	SDRAM (DIMM) Provides 32MB of memory
	PL-EM230	SDRAM (DIMM) Provides 64MB of memory
FDD Unit	PL-FD200	IBM PC Compatible 3.5" FDD unit (Attaches to side slot)
	PL-FD210	IBM PC Compatible 3.5" FDD unit (Attaches to front slot) (Only with PL-B910)
HDD Unit	PL-HD220	2.5" HDD unit (10GB or larger-contains no preinstalled OS)
FFD Unit	PL-FF200	20MB Flash File Disk with IDE interface. Used the same way as an HDD.
Mirror Disk Unit	PL-MD200-HU01*1	IDE type mirror disk unit without OS. Continuously backs up data to 2nd drive, to protect against an HDD malfunction. Contains two 2.5 inch, 2.1GB hard disk drives.
-5V/-12V Power Unit	PL-PW100	Provides -5V and -12V power to expansion slots. Can provide a total of 200mA of current. (sum of both slots)
LAN Board	DAX-IET02	NE2000 compatible Ethernet board. Provides connectors for 10BASE-5, 10BASE-2 & 10BASE-T.
Display Expansion Board	PL-PE200	Connects an additional DU unit to the PL. (Only with USB connection)
CD-ROM Unit	PL-DK200	IDE (AT API) compliant CD-ROM drive unit – for development and maintenance use (special connection cable is included)
19 Inch Mounting Panel	PL-RM200	Used to install the PL into a 19 inch rack.
Full-sized Cover	PL-FC200	Attached when an ISA or PCI bus full-sized board is used in the expansion slot. (for PL-B911)
	PL-FC210	Attached when an ISA or PCI bus full-sized board is used in the expansion slot. (for PL-B910)
Windows® 95 Touch Panel Device Driver	PL-ME000	Required for all PL units sold with no OS. Can be used only with a PL using Windows® 95. To use Windows NT® 4.0, use the Gunze company's TT-WIN/NT driver.

*1 This is the package deal product only with the PL without OS or the Hard Disk not built-in PL.



- When using the FDD unit with PL-B910 (4-slot type), either the side mount FDD unit (PL-FD200) or the front mount FDD unit (PL-FD210) is available, not simultaneously.
- PL with three IDE interfaces, two (2) of which can be used by the HDD or FFD units, and one (1) which can be used by either the CD-ROM drive or the Mirror Disk unit. Physically, even though up to three (3) IDE drive units can be connected at the same time, IDE interface specifications require that a controller's simultaneous operation be limited to a single master and slave unit, for a total of two devices.

The following chart shows the combinations available when using two IDE units.

HDD Unit	MS	M	M	M	S				S		
FFD Unit		S			M	MS	M	M		S	
Mirror Disk Unit			S				S		M	M	M
CD-ROM Drive Unit				S				S			S

MS: Any combination of 2 units - Master or Slave, is possible.

M: Used only for Master.

S: Used only for Slave.

■ Maintenance Options

Name	Model Number	Description
Mirror Disk Unit Replacement HDD	PL-MD200-MD01	Mirror Disk Unit's replacement HDD (1)



- *Since the PL unit's hard disk drive (HDD) is a consumable item, i.e. it has a limited lifetime, be sure to back up its data regularly and prepare a spare HDD unit.*
- *The Hard Disk lifetime given here may be reduced due to unforeseen environmental factors, however, generally speaking, at an operating temperature of 20°C the disk should last for 20,000 hours (of operation) or approximately 5 years, whichever comes first.*

■ Commercially Available Items

- When using an RS-422 cable to connect a Touch Panel, be sure to use the Gunze Company's [TT-WIN/NT] Touch Panel Device Driver if you install the Windows NT® 4.0 system. If you decide to install the Windows® 95 system, please use Digital's Windows® 95 Touch Panel Device Driver PL-ME000.
- The PL-B900 and PL-B910 Series units can all use commercially available expansion boards (PCI/ISA compatible) as well as a standard keyboard, mouse, printer, etc. When using a USB cable, the PL-B910 Series units can also use USB compatible devices. However, among the commercially available USB devices, not all will be compatible with the PL unit. For a list of the USB units that can be used with your PL, please contact your local PL distributor.



When a high-speed USB device is used (12Mbps) an error can occur and the device can malfunction. (Ex. MO drives, PC Card and FDD units)



- Since the PL expansion slots do not supply DC-5V and DC-12V current. To use expansion boards requiring DC-5V or DC-12 V, the optional PL-PW100 power supply should be installed.
- Be sure to use only DIM modules made by Digital Electronics Corporation. Certain commercial DIM modules may fail to meet the PL unit's specifications and cause the PL to malfunction.
- When using USB type devices, be sure they are USB compatible, and be sure to read that device's installation guide prior to connecting it to the PL.

Memo

Chapter

2 Specifications

1. General Specifications
2. Functional Specifications
3. Interface Connector Specifications
4. PL Part Names and Features
5. Panel Dimensions

2.1 General Specifications

2.1.1 Electrical

	PL-B910	PL-B911
Input Voltage	AC100V to AC240V	
Rated Voltage	AC85V to AC265V	
Frequency	50/60Hz	
Allowable Voltage Drop	1 cycle or less (however, pause occurrences must be more than 1 second apart)	
Power Consumption	150VA or less	100VA or less
Voltage Endurance	AC1500V 20mA for 1 minute (between charging and FG terminals)	
Insulation Resistance	10M Ω or higher at DC500V (between charging and FG terminals)	

2.1.2 Structural

		PL-B910	PL-B911
Ambient Operating Temperature (Panel Interior/Panel Face)	W/Fan	5°C to 50°C	
	W/out Fan *1	5°C to 40°C	
Storage Temperature	-10°C to 60°C		
Ambient Humidity	30%RH to 85%RH		
Air Purity Level	Free of conductive particles and dust		
Atmosphere	Free of corrosive gasses		
Vibration Resistance	19.6m/s ² at 10Hz to 25Hz in X, Y, Z directions for 30 minutes With Hard Disk attached: 4.8m/s ² With Floppy Disk attached: 9.8m/s ²		
Noise Endurance (via noise simulator)	Noise Voltage: 1500V Pulse Width: 50ns, 500ns, 1 μ s Rise Time: 1ns		
Noise Immunity	2kV IEC 61000-4-4		
Electrostatic Discharge Immunity	4kV IEC 61000-4-2		

*1 When the PL's internal cooling fan is removed.



When using any of the PL's optional devices, be sure to check that

- *device's specifications for any special conditions or cautions that may apply to its use.*
- *When using a full sized expansion board, be sure to check its dimensions and shape, since they will affect the PL's environment specifications, such for vibration, etc.*
- *Since the PL unit's hard disk drive (HDD) is a consumable item, i.e. it has a limited lifetime, be sure to back up its data regularly and prepare a spare HDD unit.*
- *The Hard Disk lifetime given here may be reduced due to unforeseen environmental factors, however, generally speaking, at an operating temperature of 20°C the disk should last for 20,000 hours (of operation) or approximately 5 years, whichever comes first.*
- *Using the Hard Disk in an environment that is excessively hot and/or humid will shorten the disk's usage lifetime. A maximum wet bulb temperature of 29°C or less is recommended. This is equivalent to the following data.*

Temperature	Humidity
at 35°C	no higher than 71%RH
at 40°C	no higher than 54%RH
at 50°C	no higher than 33%RH

2.1.3 Environmental

	PL-B910	PL-B911
Grounding	Exclusive grounding only. 100Ω or less, or your country's applicable standard. *1	
Installation Method	Inside a solid, flat panel	
Cooling Method	Via cooling pipes and power supply cooling fan	
Weight	7.5kg (16.5lb) or less (with HDD and FDD installed)	6.5kg (14.3lb) or less (with HDD and FDD installed)
External Dimensions	W 330mm[12.99in.] x H 271mm[10.76in.] x D 162mm[6.38in.] (excluding projections)	W 330mm[12.99in.] x H 271mm[10.76in.] x D 116mm[4.75in.] (excluding projections)
Dimensions Including Full-sized Cover	W 385mm[15.16in.] x H 271mm[10.76in.] x D 162mm[6.38in.] (excluding projections)	W 385mm[15.16in.] x H 271mm[10.76in.] x D 116mm[4.75in.] (excluding projections)
Dimensions Including Mirror Disk Unit	W 330mm[12.99in.] x H 271mm[10.76in.] x D 166mm[6.54in.] (excluding projections)	W 330mm[12.99in.] x H 271mm[10.76in.] x D 166mm[6.54in.] (excluding projections)

*1 *Refer to 4.3.3 Grounding Cautions.*

2.2 Functional Specifications

2.2.1 General

CPU		AMD-K6 [®] -2 333MHz Processor (AMD Corporation)		
DRAM (SDRAM DIMM)		64MB Standard (2 DIMM sockets: max. of 128MB)		
BIOS		AWARD PC/AT Compatible		
Secondary Cache Memory		512KB (built-in)		
Graphics		VGA (640 x 480 dots) to XGA (1024 x 768 dots) VESA 16 colors/256 colors/32K colors/64K colors		
Video Memory		2MB (SDRAM)		
Interfaces	Video	Analog RGB I/F		
	Touch Panel	COM4 : uses Mouse Emulator USB: uses USB Touch Panel Driver (PL-B910/PL-B911)		
	Serial	RS-232C (w/FIFO)	COM1	D-Sub 9 pin (male)
			COM2	D-Sub 9 pin (male)
			COM3	D-Sub 9 pin (male)
	Printer	Centronics Standard (ECP/EPP equivalent) D-sub 25 pin, female		
	Keyboard	PS/2 Interface (mini DIN 6 pin, female)		
	Mouse	PS/2 Interface (mini DIN 6 pin, female)		
	RAS	RAS Interface (D-sub 25 pin, male)		
	Disk I/F	FDD Unit	Side Access/ 2 modes/ 3.5 inch FD	
			Front Access/ 2 modes/ 3.5 inch FD (Front face connection is only PL-B910)	
	E-IDE	2.5 inch HDD I/F PL units equipped with a built-in HDD will use a 6.0GB		
USB	USB Interface compatible with USB 1.0 1 channel (PL-B910 & PL-B911 only)			

2.2.2 Expansion Slots

	PL-B910 (4-slot type)	PL-B911 (2-slot type)	Board Size		Slot Pitch	Actual Thickness of Expansion Board
			Without Full- sized cover	With Full-sized cover		
1st slot	ISA	ISA	163 x 122 mm	163 x 122 mm	20 mm	Less than 13 mm
2nd slot	PCI	PCI	250 x 122 mm	250 x 122 mm	25 mm	Less than 18 mm
	ISA	ISA		338 x 122 mm		
3rd slot	PCI/ISA	None	250 x 122 mm	338 x 122 mm	25 mm	Less than 18 mm
4th slot	ISA	None	250 x 122 mm	338 x 122 mm	20 mm	Less than 13 mm
Power Supply	5V: 4A, 12V: 1A (total for 4 slots)	5V: 2A, 12V: 0.5A (total for 2 slots)	/	/	/	/



Note: For the 2nd and 3rd slots on the PL-B910, and the 2nd slot on the PL-B911, either a PCI or an ISA type expansion board can be used.

Reference For PL dimensions when using the full-sized cover, refer to 1-3 Optional Items.

2.2.3 Clock (RTC) Accuracy

Clock(RTC) accuracy	+180 seconds per month
----------------------------	-------------------------------

The PL unit's built-in clock (RTC) has a slight error. At the PL's specified ambient temperature and with the power turned OFF the error is +180 seconds per month. However, ambient temperature fluctuations and the age of the unit may increase this error to +300 seconds per month. If the PL unit's RTC clock accuracy is vital to system performance, regular adjustment of this clock is required.

2.3 Interface Specifications

2.3.1 Keyboard Interface

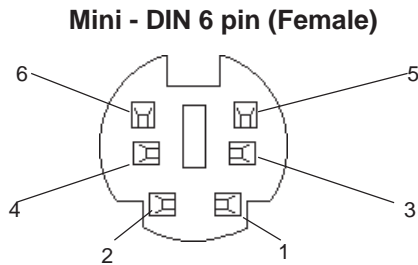

Pin No.	Signal Name
1	KEY DATA
2	NC
3	GND
4	+5V
5	KEY CLK
6	NC
SHIELD	GND

2.3.2 Mouse Interface

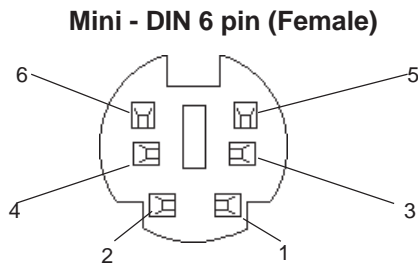

Pin No.	Signal Name
1	Mouse DATA
2	NC
3	GND
4	+5V
5	Mouse CLK
6	NC
SHIELD	GND

2.3.3 CRT Interface

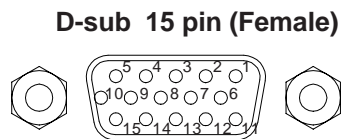

Screw Size: (4-40): Inch Type

Pin No.	Signal Name	Condition
1	Analog R	R signal input
2	Analog G	G signal input
3	Analog B	B signal input
4	Reserved	NC
5	GND	Digital signal ground
6	Return R	R signal GND
7	Return G	R signal GND
8	Return B	R signal GND
9	Reserved	NC
10	GND	Digital signal ground
11	Reserved	NC
12	Reserved	NC
13	H-SYNC	Horizontal signal Input
14	Y-SYNC	Vertical signal input
15	Reserved	NC

2.3.4 RS-232C Interface (COM1/COM2/COM3)

D-sub 9 pin (Male)

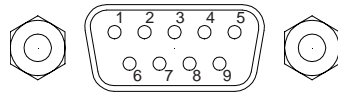

Screw Size: (4-40): Inch Type

Pin No.	Signal Name	Pin No.	Signal Name
1	CD	6	DSR
2	RXD	7	RTS
3	TXD	8	CTS
4	DTR	9	RI
5	GND		



The GND terminal is the signal ground. Be sure to connect it with the cable's opposite side SG terminal.

2.3.5 Printer Interface (LPT1)

D-sub 25 Pin (Female)

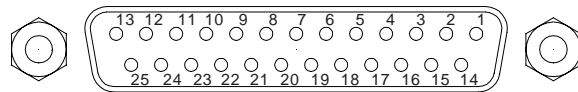

Screw Size: (4-40): Inch Type

Pin No.	SPP/ECP Mode Signal Name	EPP Mode Signal Name	Direction	Electrical Specif.	Pin No.	SPP/ECP Mode Signal Name	EPP Mode Signal Name	Direction	Electrical Specif.
1	STRB	WRITE	In/Output	O.D/T.S	14	AUTOFD	DSTRB	In/Output	O.D/T.S
2	DATA0	DATA0	In/Output	T.S	15	ERROR	ERROR	Input	TTL
3	DATA1	DATA1	In/Output	T.S	16	INIT	INIT	In/Output	O.D/T.S
4	DATA2	DATA2	In/Output	T.S	17	SLCTIN	ADSTRB	In/Output	O.D/T.S
5	DATA3	DATA3	In/Output	T.S	18	GND	GND		
6	DATA4	DATA4	In/Output	T.S	19	GND	GND		
7	DATA5	DATA5	In/Output	T.S	20	GND	GND		
8	DATA6	DATA6	In/Output	T.S	21	GND	GND		
9	DATA7	DATA7	In/Output	T.S	22	GND	GND		
10	ACKNLG	ACKNLG	Input	TTL	23	GND	GND		
11	BUSY	WAIT	Input	TTL	24	GND	GND		
12	PE	PE	Input	TTL	25	GND	GND		
13	SLCT	SLCT	Input	TTL					



Pins 1, 4, 16 and 17 will become O.D when the SPP mode specification is used. If the mode changes to ECP or EPP, these pins will become T.S

2.3.6 RAS Interface

D-Sub 25 pin (Male)

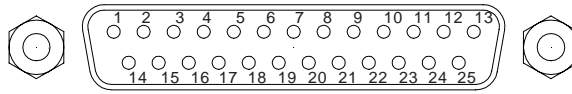

Screw Size: (4-40): Inch Type

Pin No.	Signal Name	Pin No.	Signal Name
1	GND	14	GND
2	+5V	15	+5V
3	+12V	16	NC
4	NC	17	NC
5	RESET INPUT (+)	18	NC
6	DIN 0 (+)	19	NC
7	DOUT (-)	20	NC
8	DOUT (+)	21	LAMP OUT (-)
9	ALARM OUT (-)	22	LAMP OUT (+)
10	ALARM OUT (+)	23	NC
11	RESET INPUT (-)	24	DIN1 (-)
12	DIN 0 (-)	25	NC
13	DIN 1 (+)		



Note: For detailed RAS Feature information,
Reference Appendix 2 RAS Feature.

External Input Signal (Used for both DIN and Remote Set Input)

- External Power : DC12V to DC24V
- Input Hold : Hold Diode
- Isolation : Used (Photo isolation)

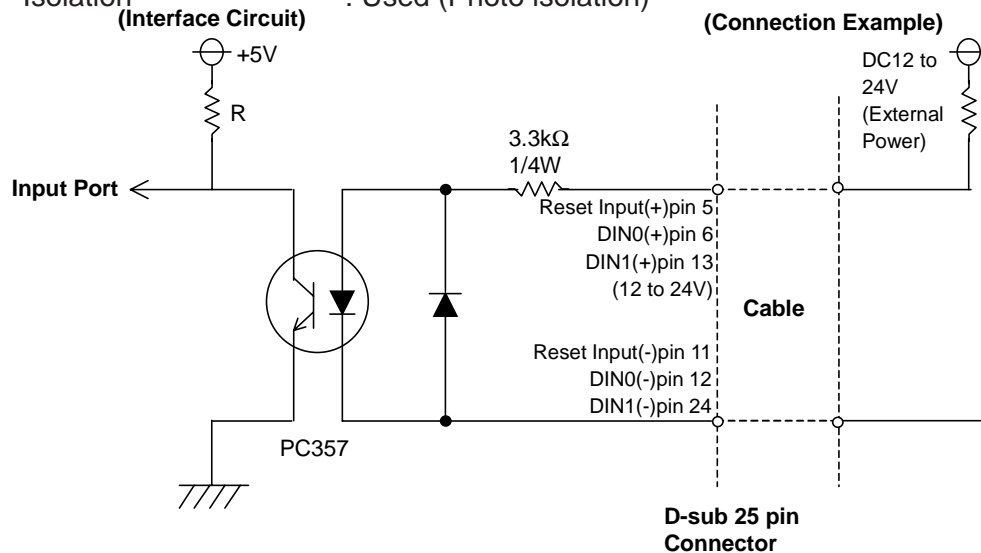

■ External Output Signal (DOOUT, Alarm Output, Lamp Output Port)

- Output Specification : DC24V 100mA (MAX)
- Isolation : Used (Photo isolation)

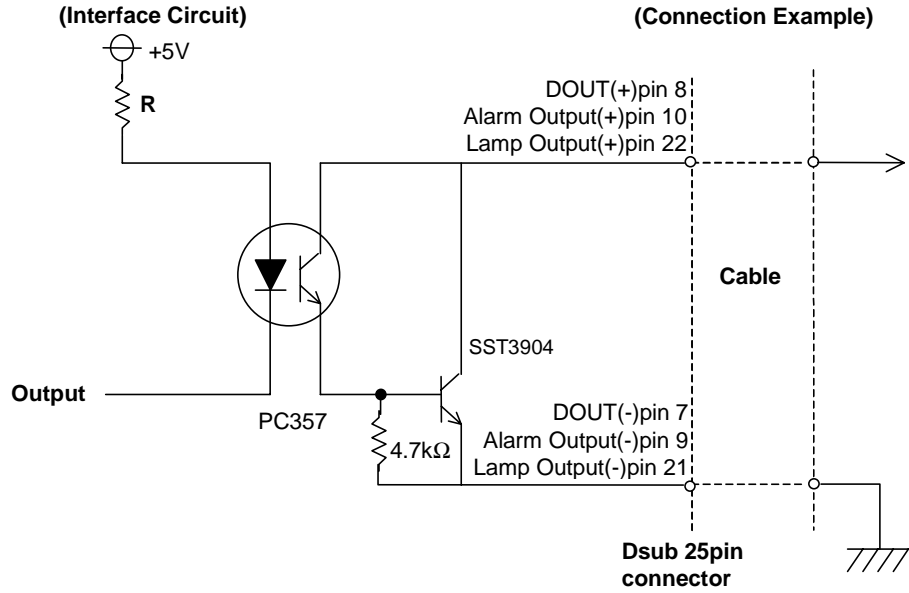

2.3.7 USB Interface (USB)

Receptacle

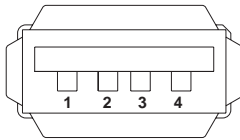

Pin No.	Name
1	Vcc
2	- Data
3	+ Data
4	GND

2.4 PL Part Names and Features

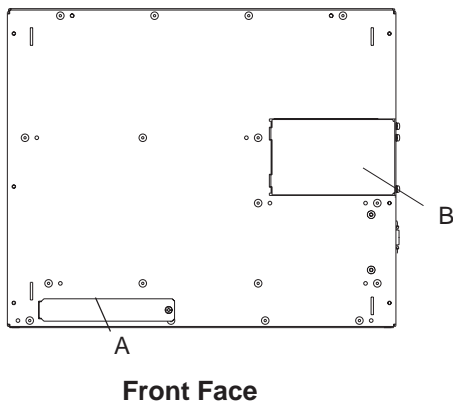

A: Front Face FDD Unit Attachment Slot

Digital's optional PL-FD210 is attached here.
(Only PL-B910)

B: Display Expansion Board Cover

Digital's optional expansion board (PL-PE200 installed here) is attached to allow the connection of an additional display unit.

C: RS-232C Connector (COM1)

D: RS-232C Connector (COM2)

E: RS-232C Connector (COM3)

These RS-232C interfaces (D-sub 9 pin male connectors), allow communication with other computers and connection to peripheral devices.

F: Printer Connector (LPT1)

Centronics standard interface (D-sub 25 pin female connector), which connects a parallel device, such as a printer. (supports ECP/EPP)

G: RAS Connector

Interface for DIN, DOUT, Watchdog, and Remote Reset. (D-sub 25 pin male connector)

H: Rear Maintenance Cover

When optional DIM modules or Expansion Boards are installed, this cover must be removed.

I: Power Terminal Block

The PL's AC100V/240V power cord terminals are connected here.

J: IDE I/F Cover

To connect the optional CD-ROM drive unit (PL-DK200) and Mirror Disk Unit (PL-MD200-HU01), remove this cover and use this connector.

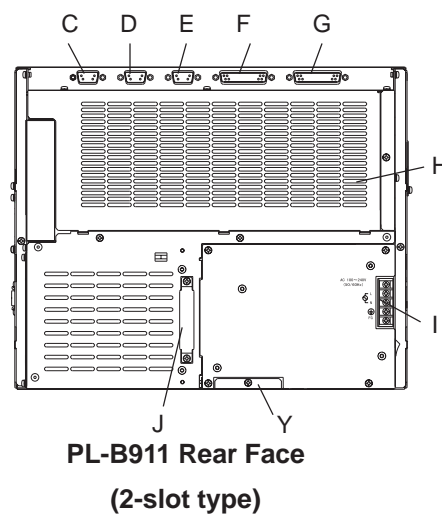
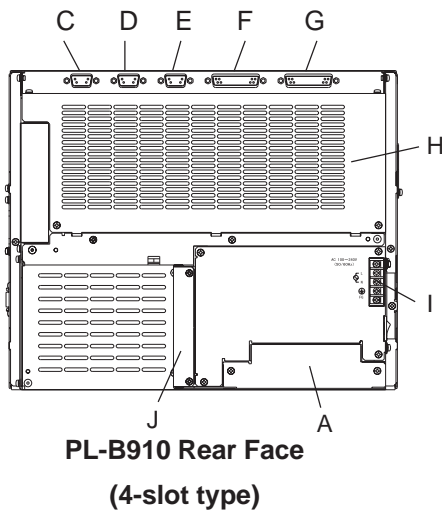

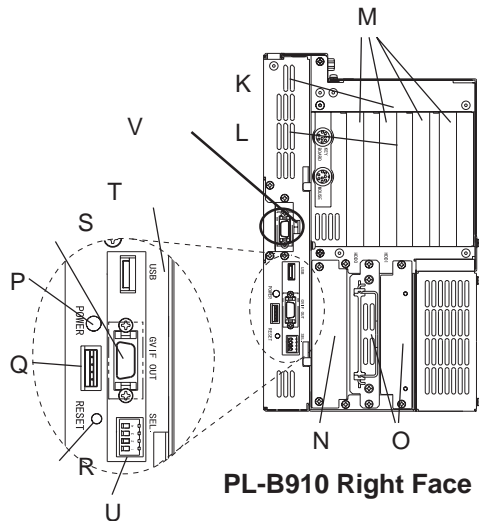

PL-B910 Right Face

K: Keyboard Connector

A PS/2 compatible keyboard can be connected here.

L: Mouse Connector

A PS/2 compatible mouse can be connected here.

M: Expansion Slots

Slots for PCI/ISA Bus compatible expansion boards.

N: Side Mount FDD Slot

Houses the FDD (PL-FD200) unit.

O: HDD/FDD Expansion Slot

Houses either the FFD or the HDD unit.

P: Power LED

This LED indicates both the RAS monitor feature's status and the PL's power status. An RAS alarm will cause this lamp to blink.

Reference *Appendix 2 RAS Feature*

Q: Power LED Output Connector

Used when installing the PL in the optional 19" mount to provide power LED output.

R: Hardware Reset Switch

Pushing this switch resets the PL.

S: Standard Display Connector (GVIF OUT)

Used to connect Digital's Standard Display Cable. (PL-CB200-*M)

T: Standard USB Connector (USB)

This interface is USB 1.0 compliant. Compatible USB devices can be connected here.

U: Dip Switches (SEL.)

These switches designate the Touch Panel connection method. Either RS-422 or USB can be selected.

Reference *1.1.1. Touch Panel Connection*

ON OFF ON OFF

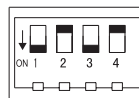

Factory Settings (for RS-422)

Be sure to set the DU unit's dip switches to the same setting as the PL.

Reference *PL-X900 Series Standard Display PL-DU6900/PL-DU7900 Users Manual.*

V: Expansion Display Connector

When using 2 DU units, Digital's display cable must be used (PL-CB200-5M). This cable connects to the PL's Display Expansion Board (PL-PE200). The picture used here shows the Display Expansion Board installed. This can only be used when using a USB cable.

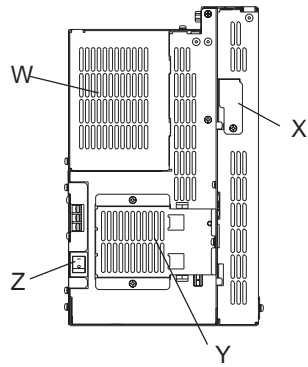

PL-B910 (4-slot type)

Left Face

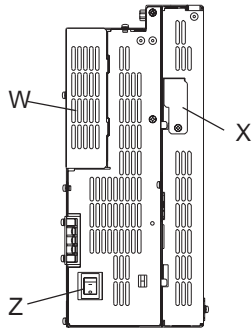

PL-B911 (2-slot type)

Left Face

W: Half Cover

When installing an optional DIM module or expansion board, this cover is removed.

X: Analog RGB Connector Cover

Provides an analog RGB interface. Remove this cover when attaching an RGB (CRT) monitor to the PL.

Y: Filter Cover

Remove this cover when cleaning or removing the PL's cooling fan.

Z: Power Switch

Turns the PL main unit ON or OFF.

2.5 PL External Dimensions

2.5.1 PL-B910 Series External Dimensions

(Unit: mm (in.) - excluding projections)

■ PL-B910 (4-slot type)

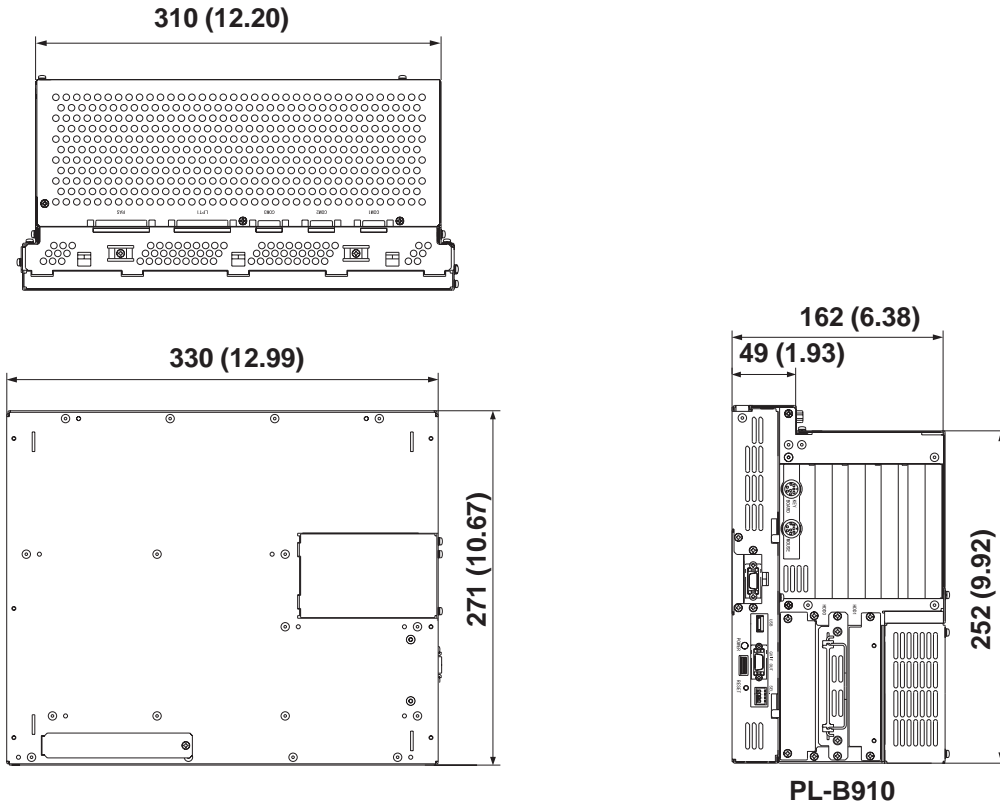

◆ Front Face Mount FDD Unit Installation Slot

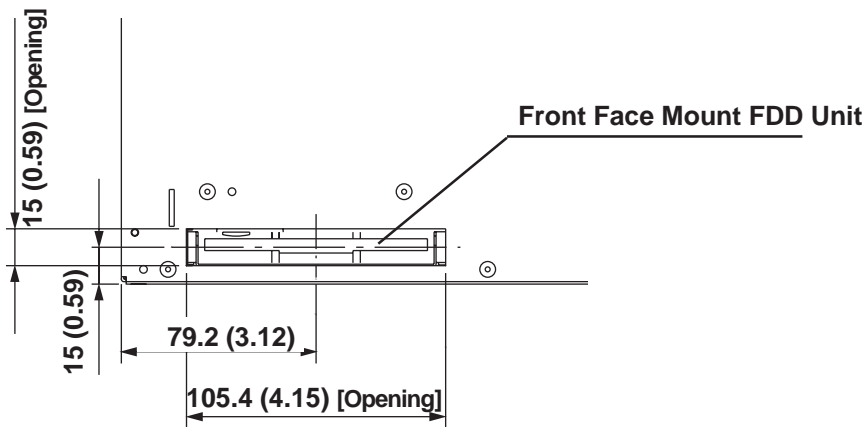

■ PL-B911 (2-slot type)

(Unit: mm (in.) - excluding projections)

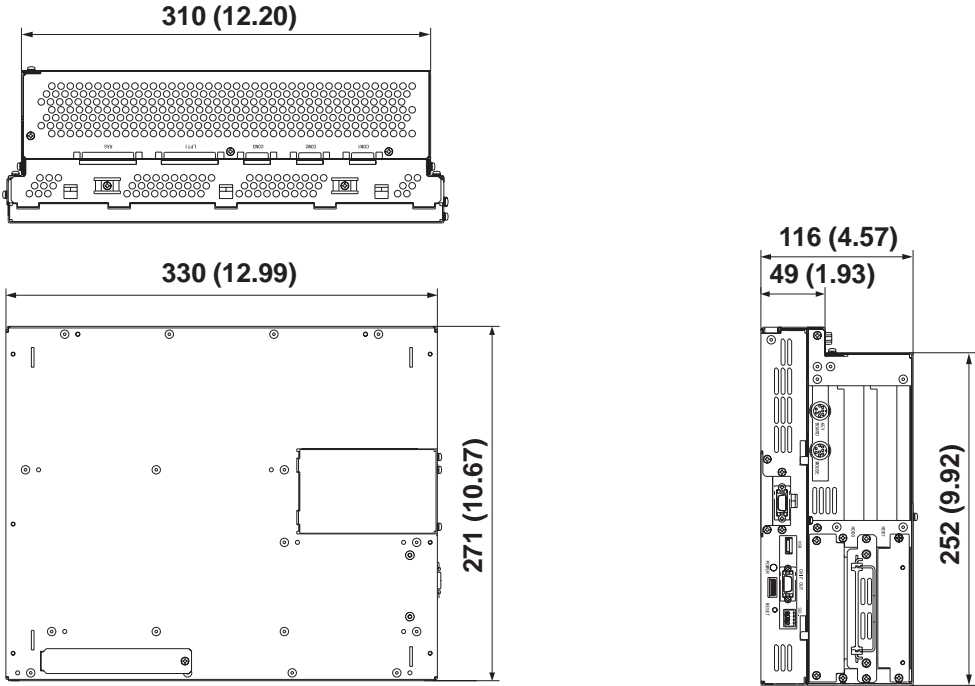

PL-B911

2.5.2 Installation Fasteners

■ PL-B910 (4-slot type)

(Unit: mm - excluding projections)

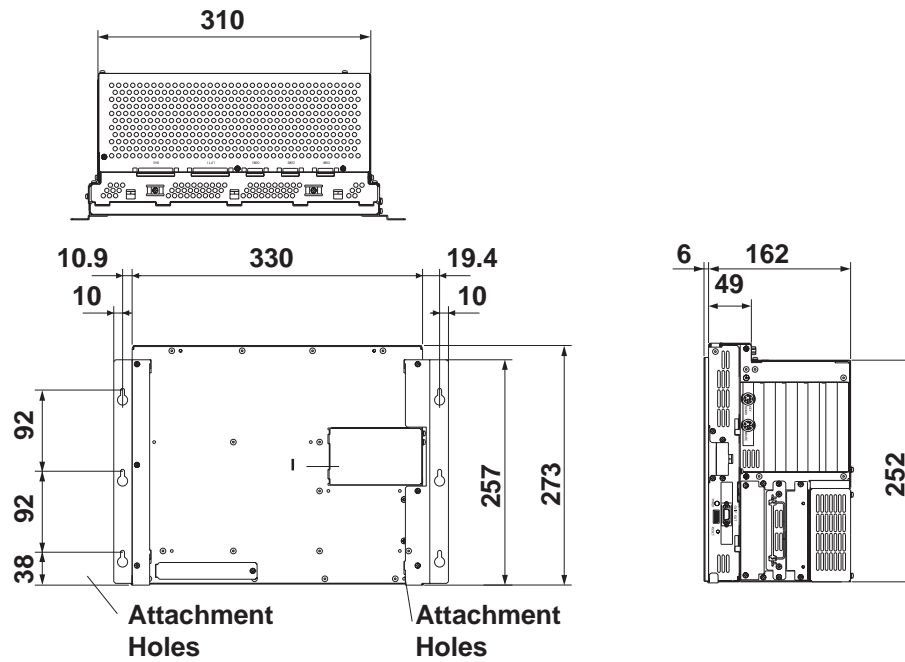

■ PL-B911 (2-slot type)

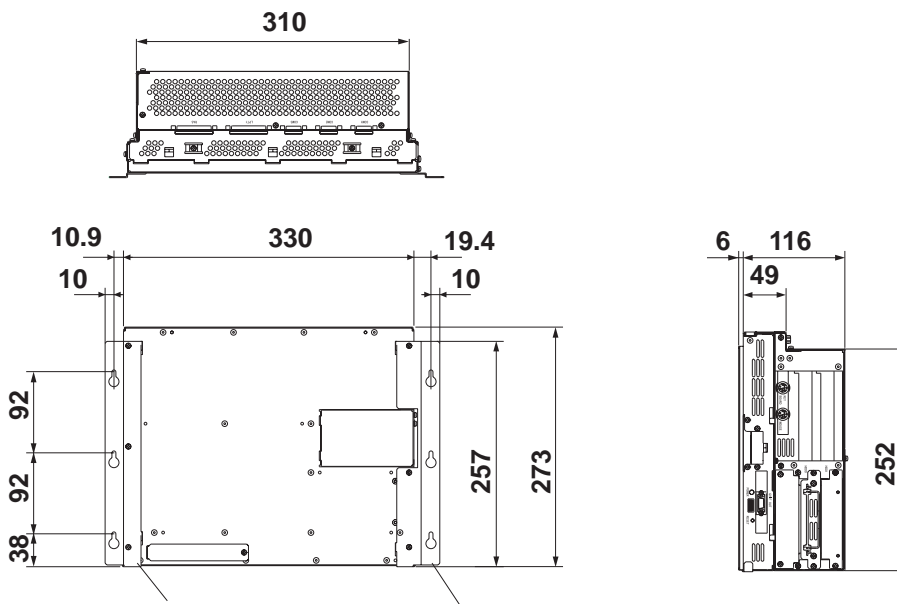

■ Attachment Bracket Attachment Holes (Detail)

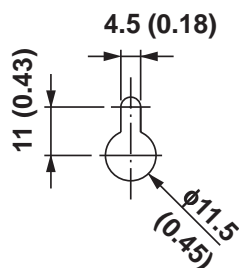

■ **Drilling Attachment Bracket Attachment Holes**

Use the following dimension drawing to drill the attachment bracket attachment holes in the installation panel. Use M4 size screws for the screw holes.

(Unit: mm(in.) - excluding projections)

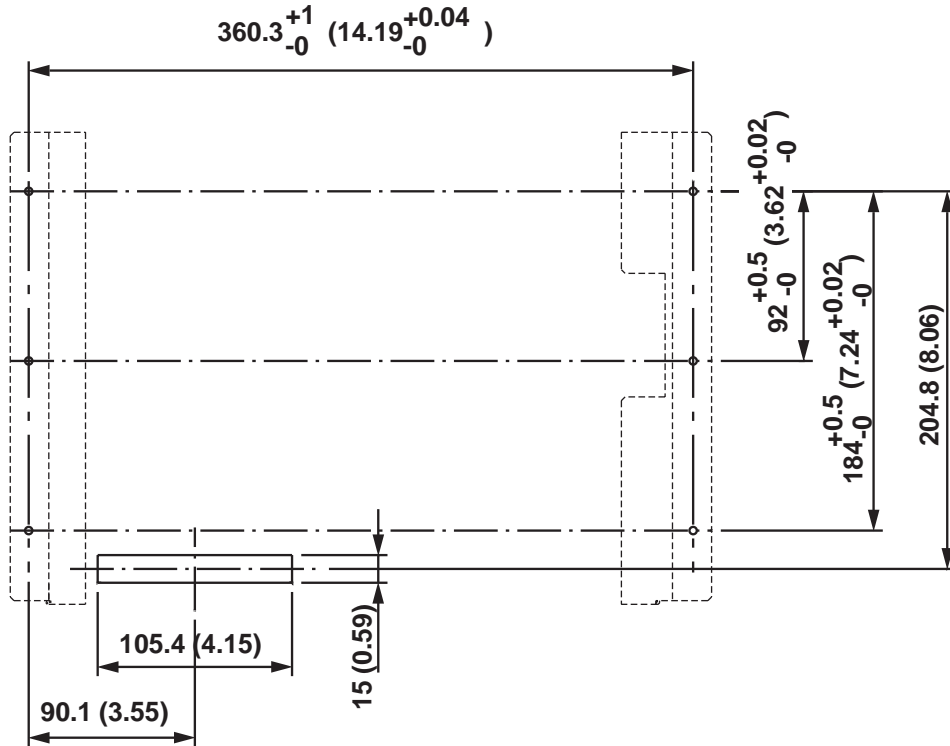

Front View



- Depending on the panel's material and design, the panel's installation surface may need to be strengthened. If high levels of vibration are expected and the PL's installation surface (i.e. an operation panel's door, etc.) can move (i.e. open or close) due consideration should be given to the PL's weight.

▼ **Reference** 2.1.3 Environmental

- Be sure all installation tolerances are maintained to prevent the unit from falling out of its installation panel.

2.5.3 Full-Sized Cover/Mirror Disk Unit Attachment Dimensions

■ PL-B910 (4-slot type)

(Unit: mm - excluding projections)

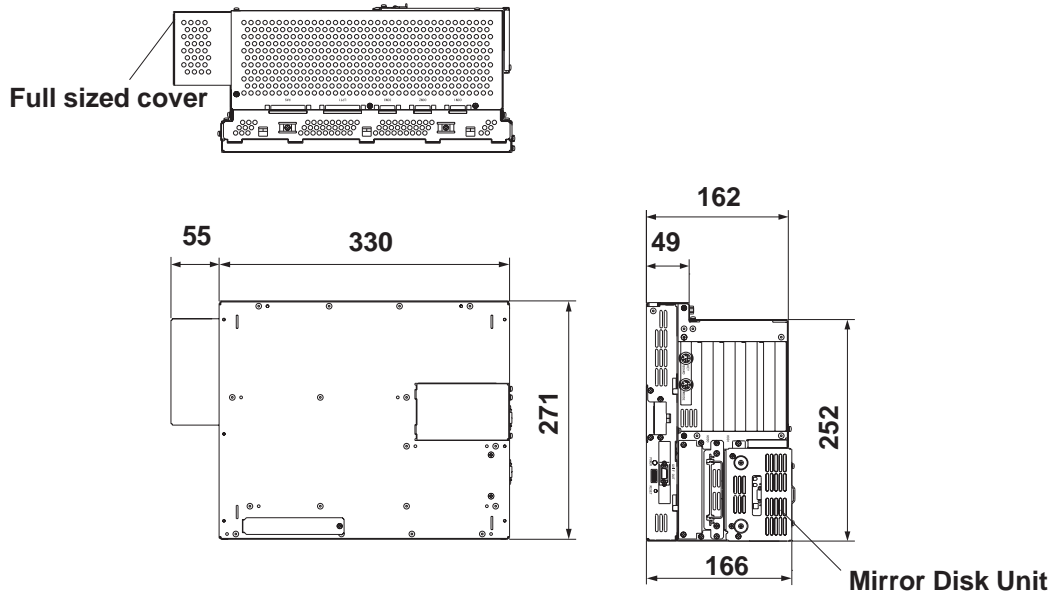

■ PL-B911 (2-slot type)

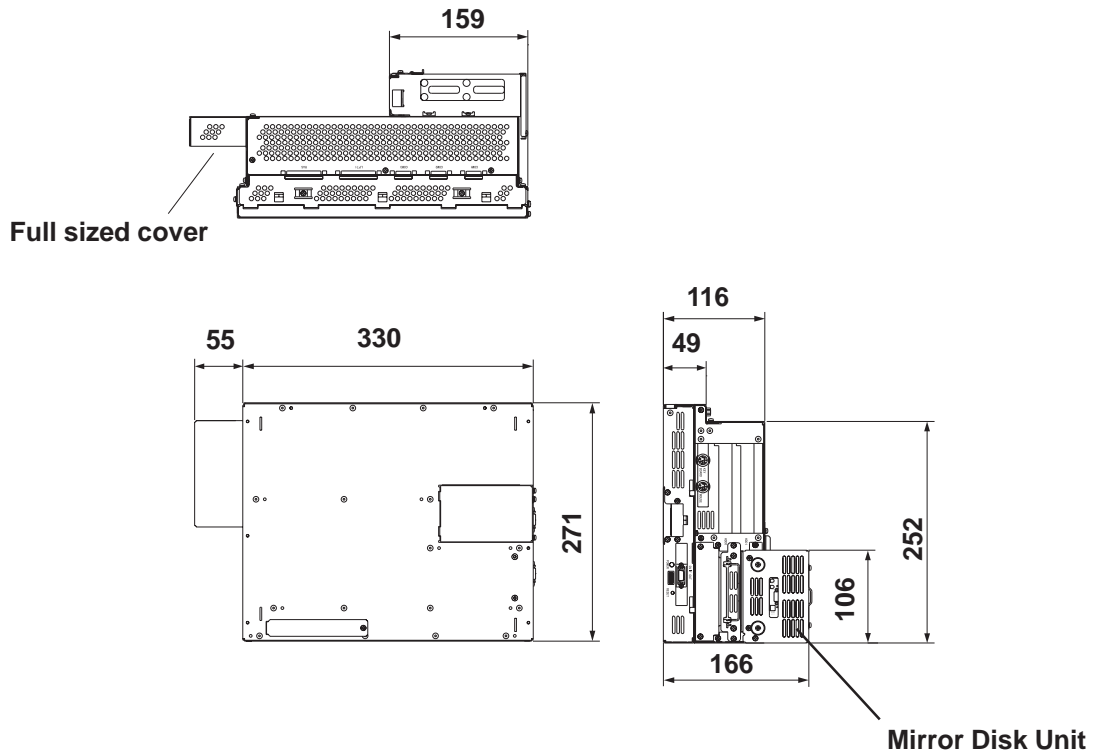

Note: There are two types of full-sized covers - one for 4 slot units (PL-B910) and one for 2 slot units (PL-B911).

2-Slot Type PL-FC200

4-Slot Type PL-FC210

Reference 1.3 Optional Items



- ***Prior to installing a full-sized board and the PL's full-sized cover (PL-FC200/PL-FC210), be sure that the PL is mounted in its attachment panel/cabinet. Due to dimension differences, a full sized expansion board and PL's full-sized cover can not be attached prior to installing the PL into a panel.***
- ***When using a full sized expansion board, be sure to check its dimensions and shape, since they will affect the board's environment specifications, such as for vibration, etc.***

Memo

Chapter

3

Installing Optional Units and Expansion Boards

A wide variety of optional units and expansion boards made by Digital can be installed in the PL, as well as a number of commercially available PCI-bus or ISA-bus compatible boards. This chapter describes how to install these products in the PL.

3.1 Installation

The following explanation pages describe the installation procedures for the PL's DIM module (PL-EM220/PL-EM230), FDD unit (PL-FD200/PL-FD210), HDD unit (PL-HD220), expansion boards, CD-ROM drive unit (PL-DK200), Display Expansion Board (PL-PE200), Special Display (PL-DU6900/PL-DU7900) and the PL's cooling fan.

For information about the installation of other option units, please refer to those unit's individual [Operation Instructions].



WARNING

To avoid electric hazards, be sure to turn the PL's power OFF before installing any optional units or expansion boards.



- **Use a screwdriver to loosen or tighten the screws. Be careful not to tighten screws too tightly, since it may damage the equipment.**
- **Be careful when removing or inserting any screws that they do not fall inside the PL.**

3.1.1 Removing the Rear Maintenance Cover



Be sure to handle the rear maintenance cover carefully, since it is made of aluminum and is easily bent.

■ **PL-B910 Units (4 -slot type)**

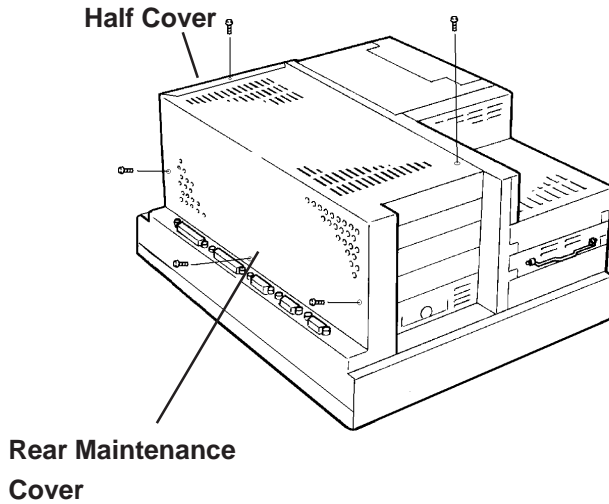

1) **Unscrew the five (5) attachment screws used to hold the rear maintenance cover and half cover.**

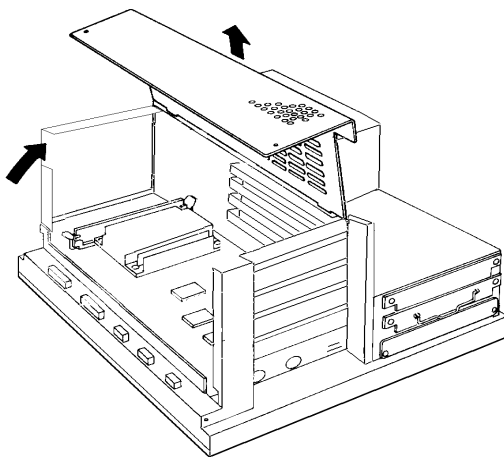

2) **Remove the rear maintenance**

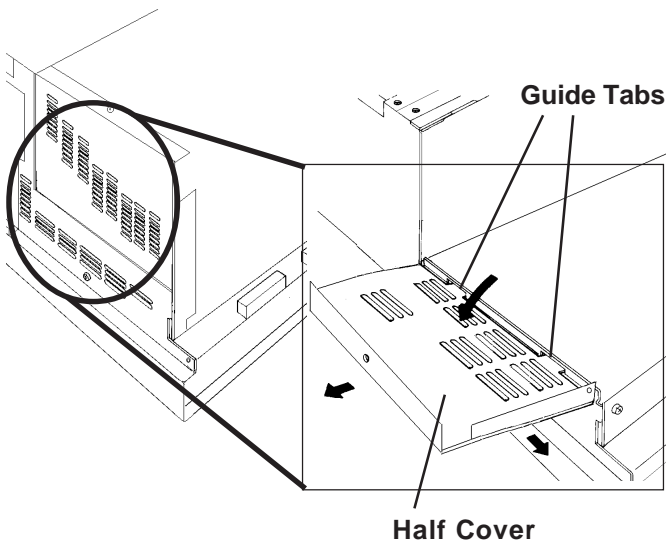

3) **Pivot the half cover open and lift up slightly to free the guide tabs. Next, remove the half cover.**

■ PL-B911 Unit (2-slot type)

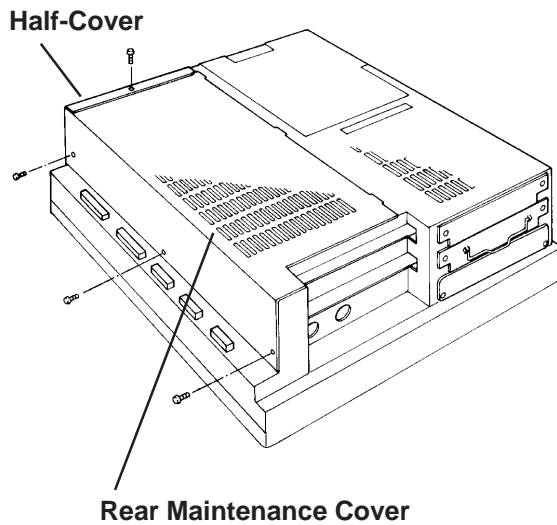

- 1) Unscrew the four (4) attachment screws used to hold the rear maintenance cover and half cover.

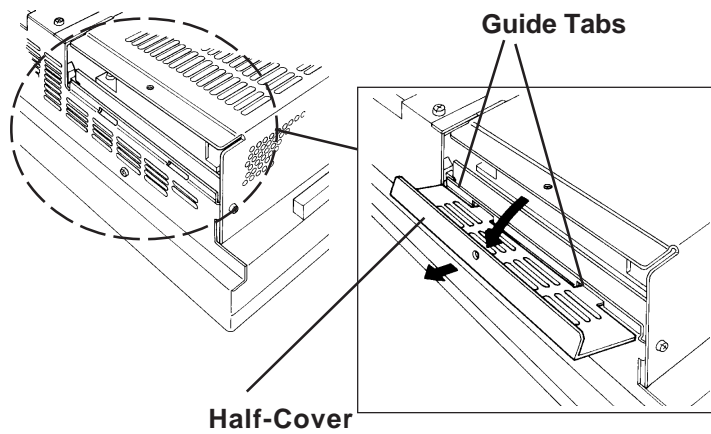

- 2) Pivot the half cover open and slide the cover slightly to the side to free the guide tabs. Next, remove the half cover.

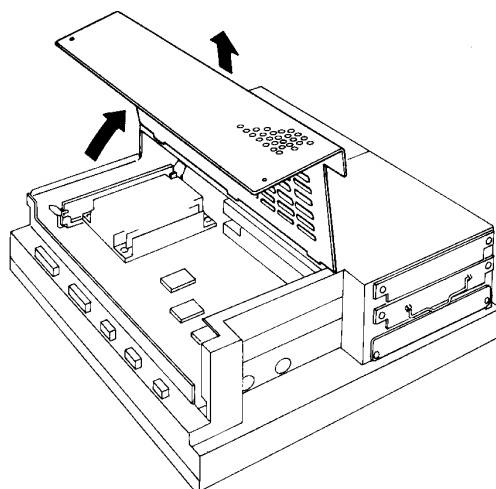

- 3) Remove the rear maintenance cover.

3.1.2 Installing the DIM Module (PL-EM220 / PL-EM230)



- **Since DIM module sockets are fragile and break easily, be sure to install the DIM module carefully.**
- **Do not change the factory installed DIM module's socket position.**

The PL comes with a single, 64MB DIM module pre-installed. There is one more empty socket that can be used to expand you PL unit's memory. Use the following procedure to install a second DIM module in that socket.

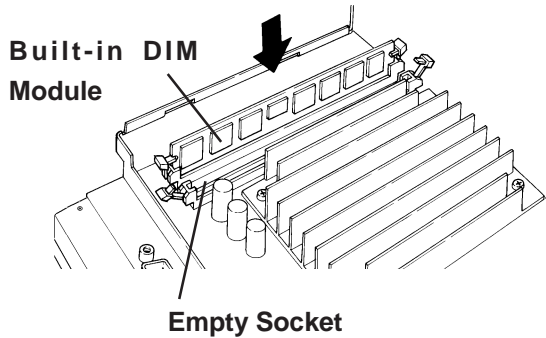

- 1) **Install the DIM expansion module in the empty socket.**

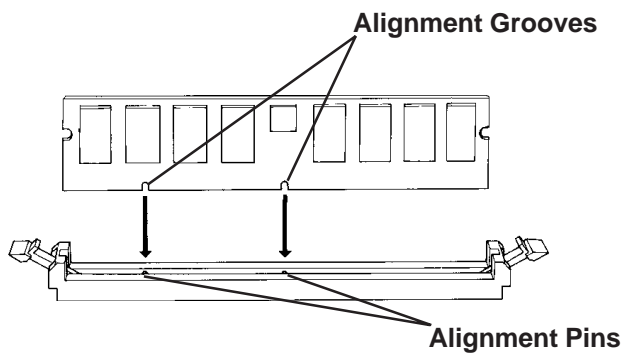

- 2) **Position the Alignment Grooves so that they fit the Alignment Pins.**

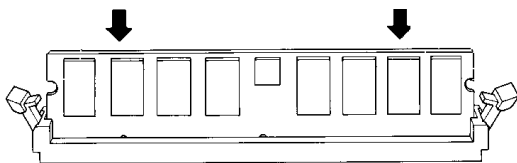

- 3) **Insert the DIM module into the DIM module socket.**

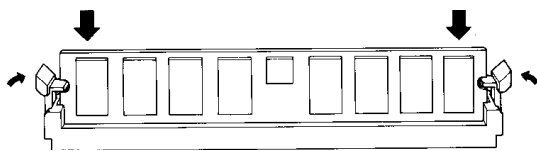

- 4) **Push the DIM module down until the ejector tabs lock.**

- 5) **Replace the rear maintenance cover and the half cover and secure them in place with their attachment screws.**

◆ To Remove the DIM Module

To remove a module, press down on the socket's ejector tabs to release the module.

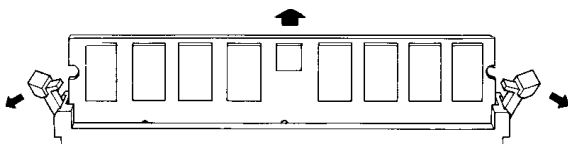

3.1.3 Installing the FDD Unit (PL-FD200)



The PL-FD200 and the PL-FD210 cannot be used at the same time.

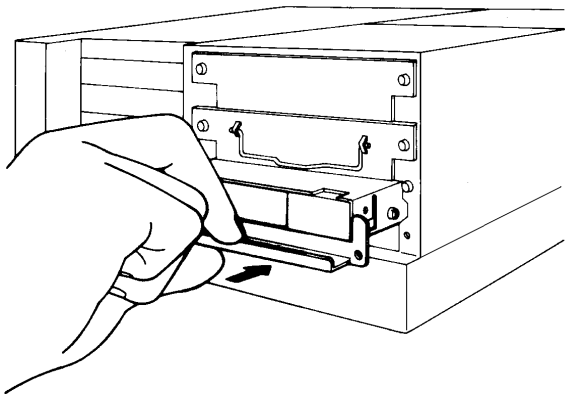
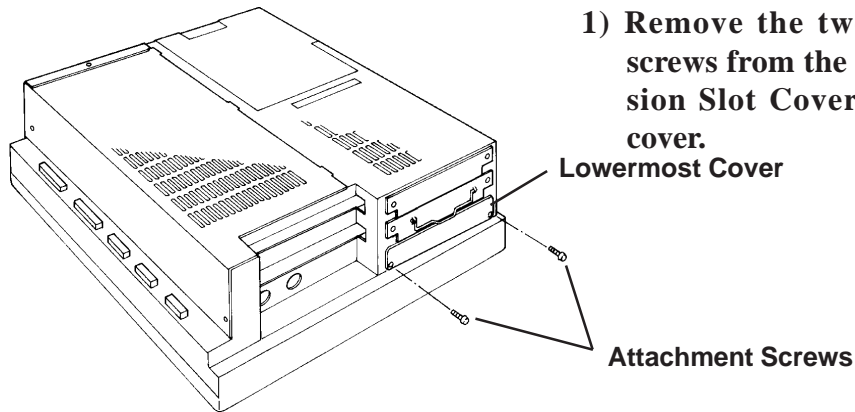

2) Insert the FDD unit so that its guide grooves fit the slot's guide ways. Push the unit in until its rear connector is connected securely.

3) Secure the unit in place with its two(2) attachment screws.

3.1.4 Installing the FDD Unit (PL-FD210)



- The PL-FD-210 can only be used with the PL-B910 (4-slot type) units, and cannot be used with the PL-B911 (2-slot type) units.
- The PL-FD200 and the PL-FD210 cannot be used at the same time.

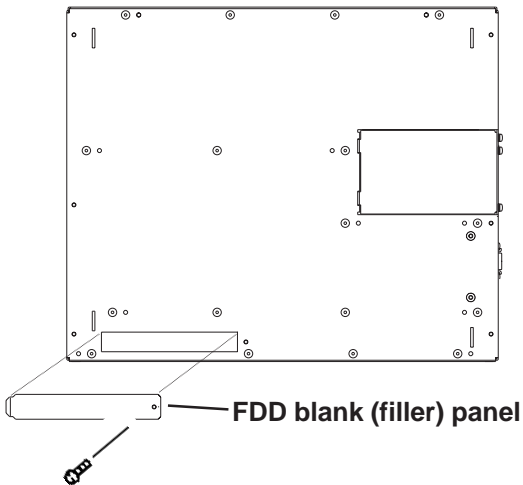

- 1) Unscrew the PL front face's FDD blank panel's attachment screw (1). Remove the blank panel.

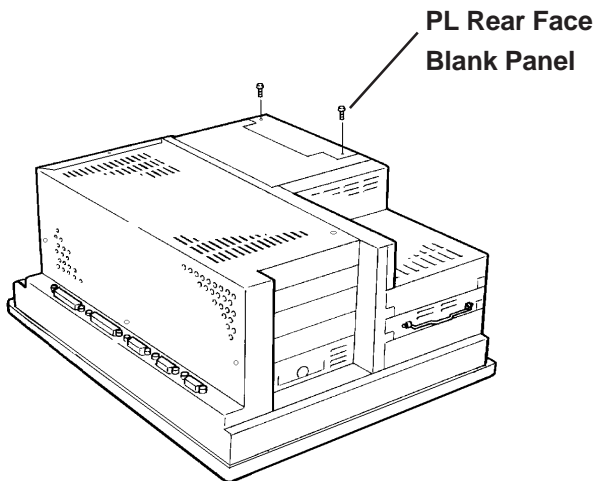

- 2) Unscrew the two (2) attachment screws from the PL's Rear Face Blank Panel, and remove it.

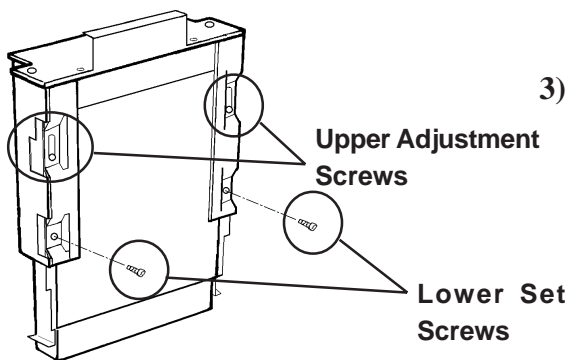

- 3) Loosen the FDD unit chassis two (2) upper adjustment screws, and remove the unit's two (2) lower set screws to allow the FDD unit to slide forward.

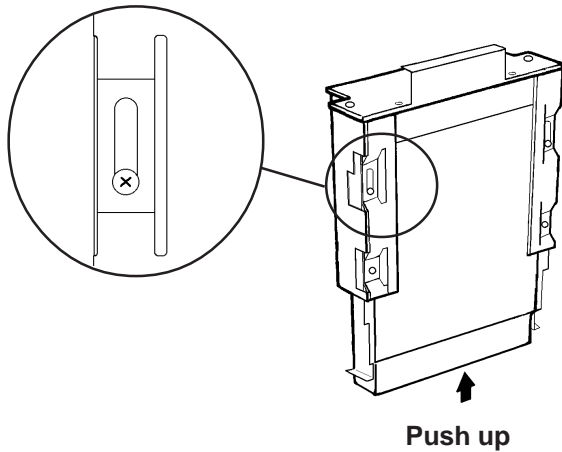

- 4) Push the unit in the direction of the arrow so that the adjustment screw is in the top-most position. Next, secure the unit in place by tightening all four (4) (upper and lower) screws.

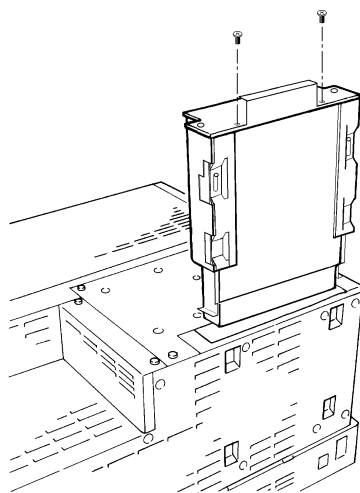
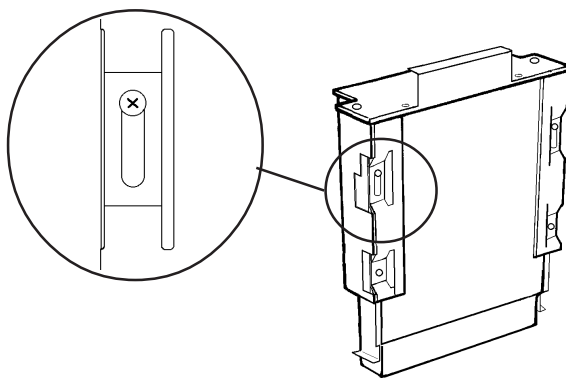

- 5) Insert the FDD unit so that its guide grooves align with the chassis holder guideways. Push the unit into the PL holder until its connector (middle of unit) is connected securely.



When installing the PL-FD210, insert it slowly into the PL's installation opening and be sure it is securely attached.

- 6) Fix the unit in place with its two(2) attachment screws.
- 7) Last, replace the Blank Panel (removed in step 3).

3.1.5 Removing/ Installing the HDD Unit (PL-HD220)



- The following insertion/removal procedure is applicable also to the FFD(PL-FF200) unit and the HDD unit.
- Certain usage limitations apply to the HDD, FFD, Mirror Disk and CD-ROM Drive.

Reference 1.3 Optional Items



Since the HDD unit is a precision instrument, be sure not to subject it to sudden shaking or shocks.

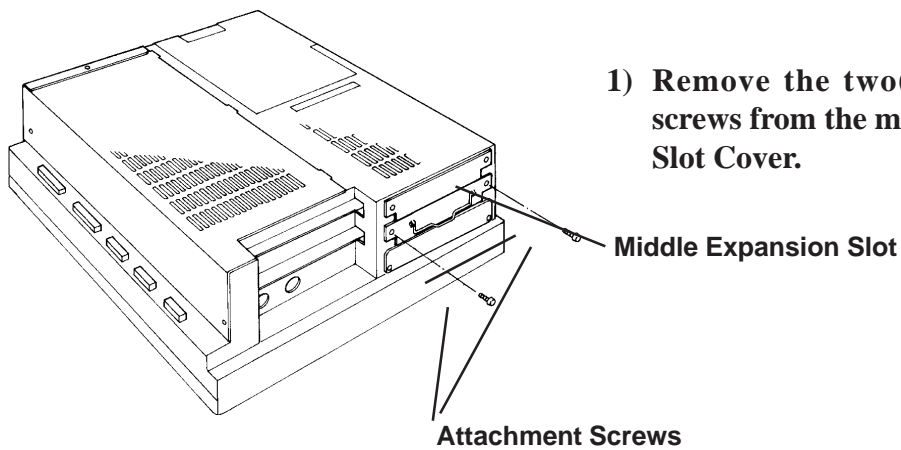

- 1) Remove the two(2) attachment screws from the middle Expansion Slot Cover.

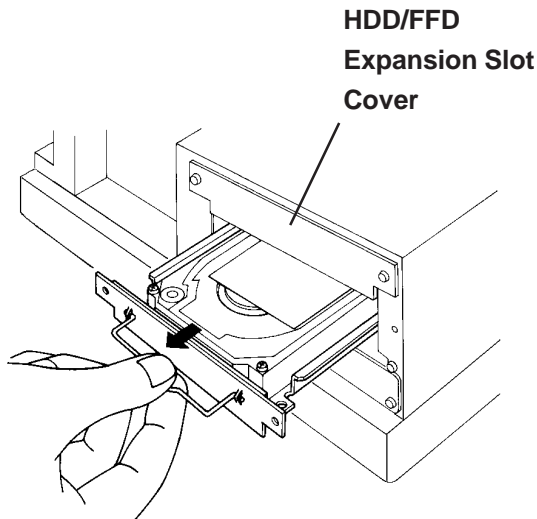

- 2) Grasp the HDD unit's handle and pull the unit slowly out of the PL. Be sure you do not damage the unit.

- 3) Insert the new HDD unit into the PL's guideways and push it in until its rear connector is securely connected.

- 4) Fix the unit in place with its two(2) attachment screws.



Reattach the Expansion Slot cover using the same steps.

3.1.6 Installing an Expansion Board

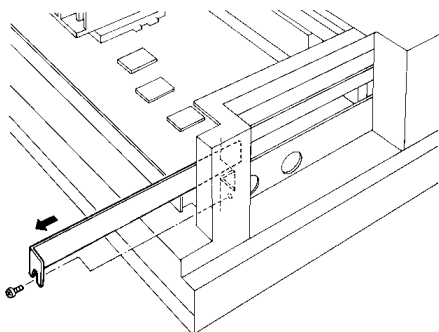

- 1) Unscrew the desired expansion slot's cover attachment screw, and remove the cover.

Reference 3.1.1, *Removing the Rear Maintenance Cover*

Unscrew the Blank Panel's attachment screw to remove the Blank Panel.

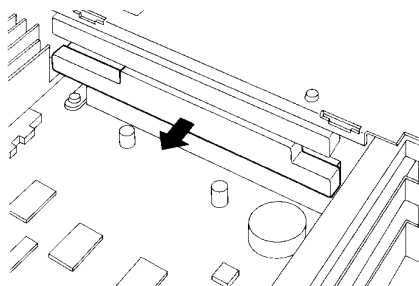

- 2) Remove the expansion slot's duster cover.

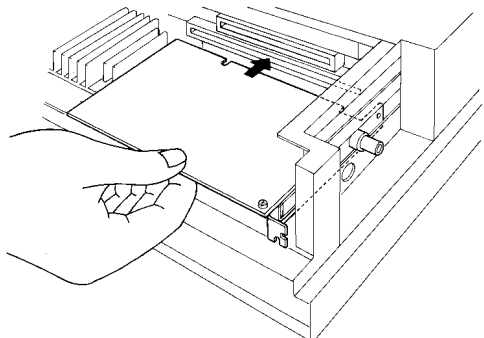

- 3) Insert the expansion board into the expansion slot.

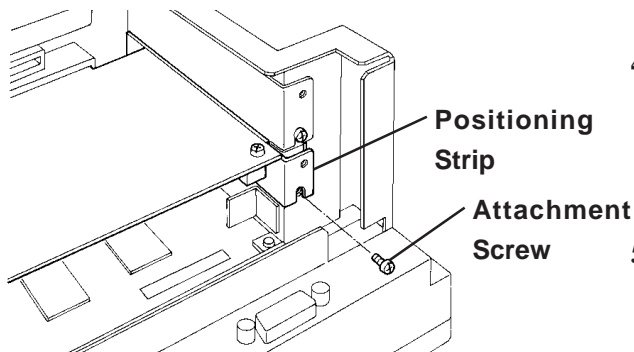

- 4) Secure the expansion board's metal positioning strip in place with its attachment screw.

- 5) Last, replace the rear maintenance cover and half cover and secure them in place with their attachment screws.

3.1.7 Connecting the CD-ROM Unit (PL-DK200)

When using the CD-ROM unit, be sure to change the System Information area's "Integrated Peripherals" [IDE Primary Master PIO] and [IDE Primary Slave PIO] settings to [Mode 2], or set [IDE Primary Master UDMA] or [IDA Primary Slave UDMA] to [Disabled]. **Reference** 5.2.9 *Integrated Peripherals*.

■ PL-B910 Unit (4-slot type)

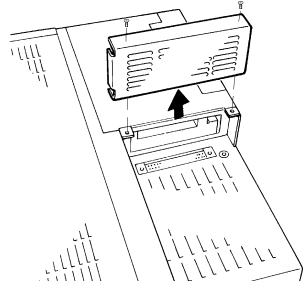

- 1) Unscrew the two (2) IDE I/F cover attachment screws, and remove the cover.

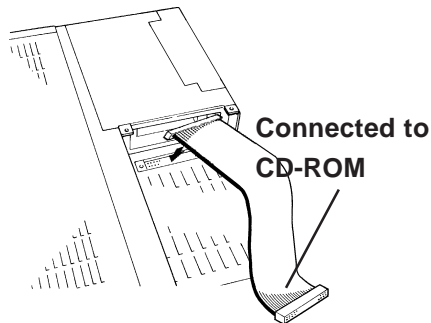

- 2) Connect the CD-ROM unit cable to the PL's IDF I/F connector.



Be sure that the cable is securely connected before turning ON the PL's power switch.

■ PL-B911 Unit (2-slot type)

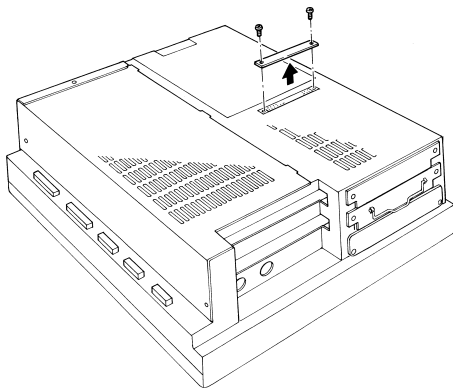

- 1) Unscrew the two(2) IDF I/F cover attachment screws, and remove the cover.

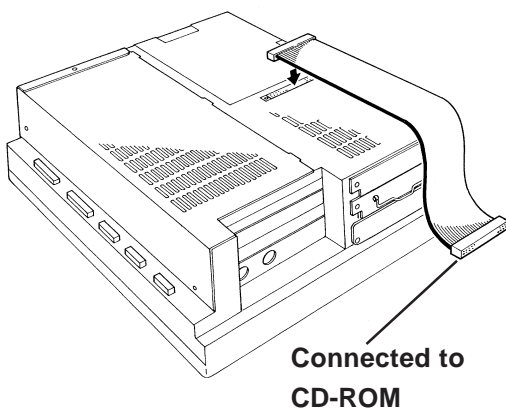

- 2) Connect the CD-ROM unit's cable to the IDF I/Fconnector.



Be sure that the cable is securely connected before turning ON the PL's power switch.

3.1.8 Attaching the Display Expansion Board (PL-PE200)

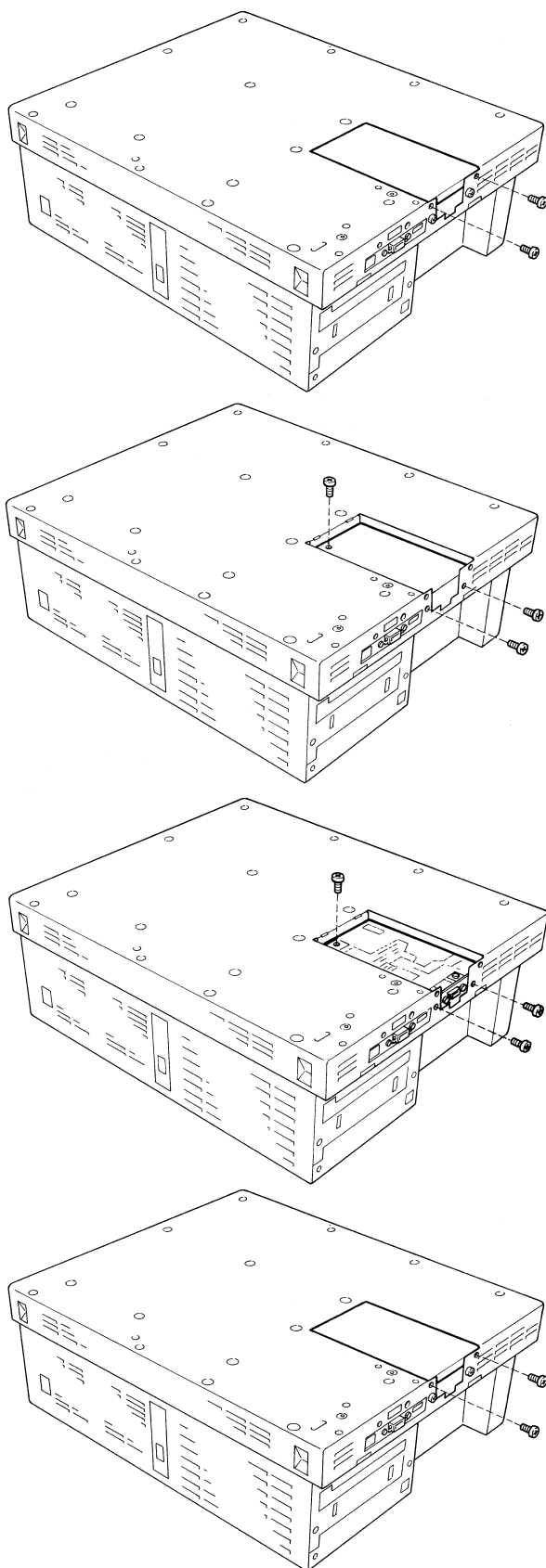

- 1) Unscrew the PL's two (2) Attachment Screws and remove Cover A. (outermost cover)



Be sure to place the PL unit on a flat, level surface prior to installing the PL-PE200. This will prevent both damage to the PL and the accidental cutting of the power cord terminals.

- 2) Unscrew the three (3) Attachment Screws and remove Cover B. (inner cover)

- 3) After checking that the PL and the PL-PE200 connectors are correctly aligned, insert the PL-PE200's three (3) attachment screws removed in step 2) and secure the unit in place.



- **Be sure to handle the Display Expansion Board carefully since it contains precision components.**
- **Be sure to insert the Board into place carefully, using only the necessary amount of force.**

- 4) Reattach Cover A and secure it in place with its two (2) Attachment Screws.

3.1.9 Connecting the Standard Display (DU-6900/DU-7900)

■ Connecting a Single Display (RS-422 and USB Connections)

Use the PL-CB200-10M Display Cable to connect the PL's Standard Display Connector to the DU unit's connector.

Depending on the touch panel connection method used, choose your display cable from the following table. **Reference** 1.1.1 *Touch Panel Connection*

Touch Panel Connection	Display Cable
RS-422	PL-CB200-5M PL-CB200-10M
USB	PL-CB200-5M

■ Connecting Dual Displays (USB)

Use the PL-CB200-5M Display Cable to connect the Display Expansion Board's connector to the two DU display units.

Reference 1.1.2 *Connecting the Dual Displays*

◆ Star Configuration

When using 1 DU unit:

Use Digital's Standard Display Cable (5m) to connect the PL's Standard Display connector to the DU unit's connector.

When using 2 DU units:

Use the Standard Display Cable (5m) to connect the PL's Display Expansion Board connector to the DU unit's connector.

◆ Daisy Chain Configuration

When using 1 DU unit:

Use Digital's Standard Display Cable (5m) to connect the PL's Standard Display connector to the DU unit's connector.

When using 2 DU units:

Use the Standard Display Cable (5m) to connect the first DU's Display Expansion Board connector to the second DU unit's PL connector.



Note:

- Be sure not to bend, crimp or pull the PL's Standard Display Cable.
- Be sure to insert the cable connectors together until they lock securely.
- When designating the touch panel connection type (RS-422 or USB), the PL and DU unit Dip Switches must be set. For setting details,

Reference 1.1.2 *Connecting the Dual Displays*

3.1.10 Connecting an Analog RGB Monitor

The following explanation connects the PL to a commercially available CRT monitor, or to the Flat Panel (FP) display.

■ Connecting a CRT Monitor

When connecting the CRT monitor, be sure that it is a standard analog multiscan VGA compliant type.

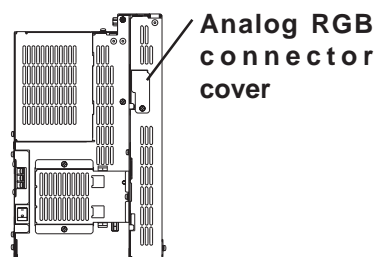

- 1) Unscrew the Analog connector cover's attachment screw, and remove the cover.
- 2) Connect the CRT monitor's cable to the PL's analog RGB connector.

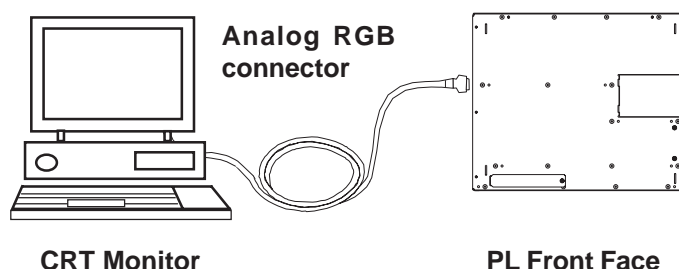

■ Connecting the FP-570

Digital's FP-570 monitor can also be connected to the PL unit. For connection details, **Reference** *FP-570 Series User Manual*.

When connecting an FP-570 series touch panel, a separately sold device driver is required. However, this driver can only be used with an RS-422 cable.

Reference *6.1.1 Touch Panel Device Driver Settings*



When the FP is connected to a PL-B910/PL-B911 (PL-B910 series) unit, the touch panel cannot be used, only the display.

When the FP is used, the user's system or OS must be set up first.

Please perform the following steps.

- 1) Connect a standard CRT monitor.
- 2) Modify the required BIOS settings **Reference** *Chapter 5 - System Setup*
- 3) Set up the PL unit's OS **Reference** *Chapter 6 - Setting Up Your PL OS*

- 4) Designate the Display (Output) device.

This is performed via the Control Panel's [Screen] settings. Open the [Screen Properties] dialog box and designate the display device as "CRT".



In [Screen Properties] dialog box, please select "CRT". Otherwise, FP-570's display device can not work.

- 5) Shut down the PL unit's OS.
- 6) Connect the FP-570.
- 7) Restart the PL unit's OS.

■ Connecting an FP-2500/FP-2600 Series Display

Use an analog RGB connector when connecting Pro-face's Flat Panel Display FP-2500/FP-2600 Series to a PL unit. For connection details, refer to the FP-2500/FP-2600 Series User Manual.

When connecting an FP-2500/FP-2600 series touch panel, a separately sold device driver is required. **Reference** 6.1.1 *Touch Panel Device Driver Settings*

3.1.11 Removing the Cooling Fan Unit

The PL units can be operated without their bottom face cooling fan unit. The user should, however, be aware that doing so (i.e. removing the fan unit) will cause the PL's ambient temperature to rise. **Reference** “2.1.2 Structural Specifications”

■ PLB910 Unit (4-slot type)

- 1) Remove the cooling filter cover's attachment screw.

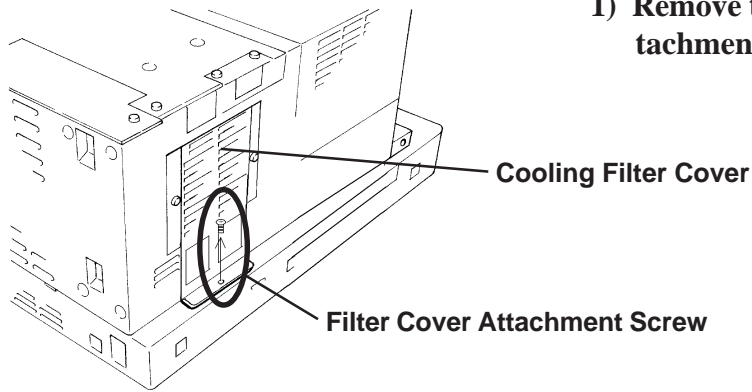

- 2) Remove the cooling filter cover from the fan unit, and then remove the fan unit's two attachment screws.

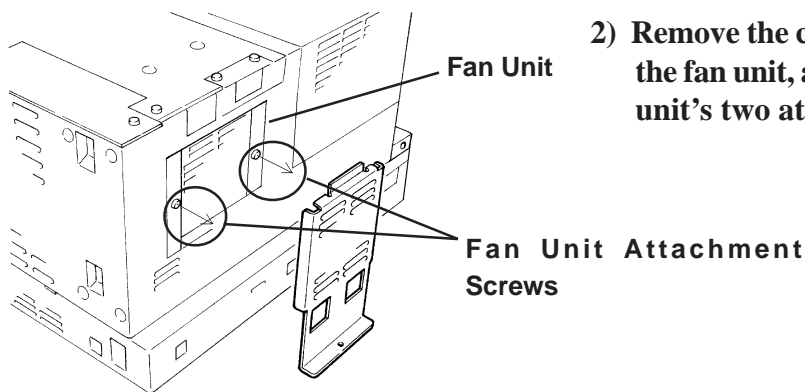

- 3) Remove the fan unit from the PL.

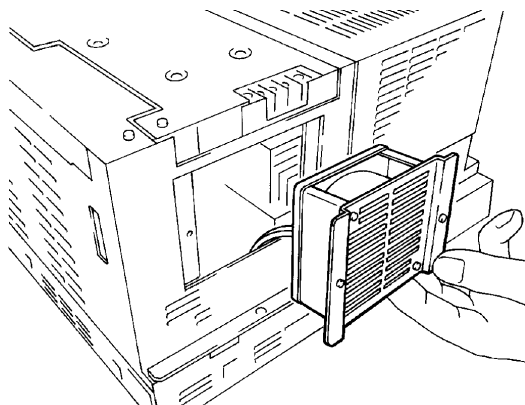

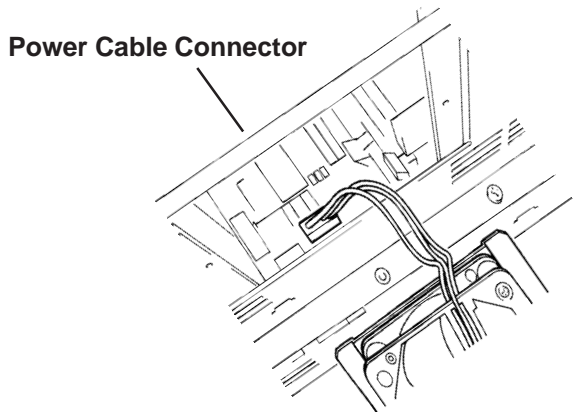

4) Disconnect the fan unit's power cable

5) Replace the cooling filter cover and re-attach the cooling filter cover's attachment screw.

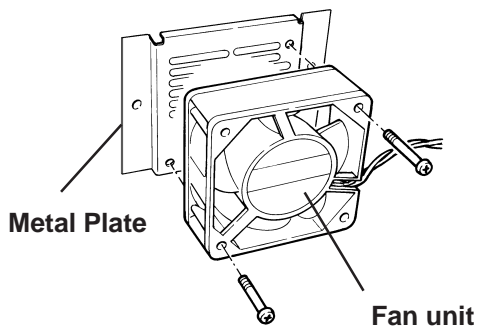

6) Unscrew the two(2) fan unit's attachment screws and remove the fan unit from the metal plate holding the fan unit.

7) Attach the metal plate and the cooling filter cover to the PL.

■ PLB911 Unit(2-slot type)

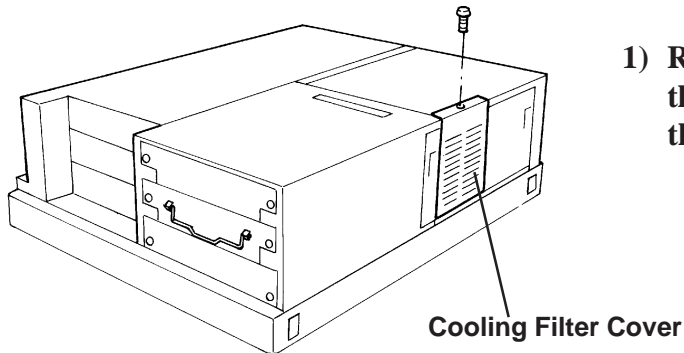

1) Remove the attachment screw on the cooling filter cover, and remove the cover.

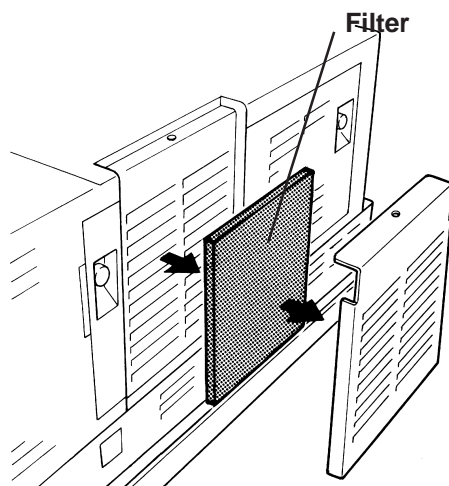

2) Remove the filter.

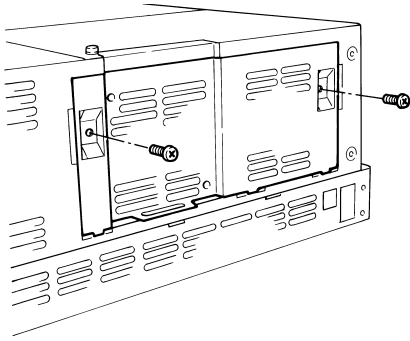

- 3) Remove the two(2) fan unit attachment screws, and take out the fan unit.

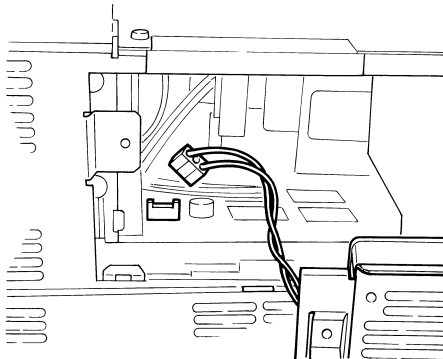
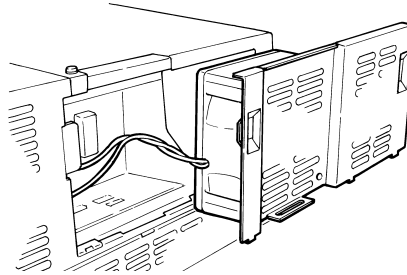

- 4) Unplug the fan unit's power cable connector from the PL.

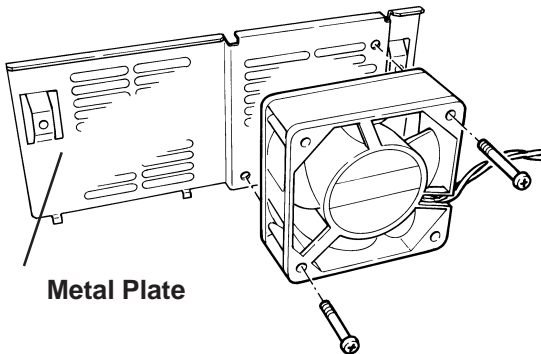

- 5) Unscrew the two (2) attachment screws and remove the fan unit, and then remove the fan unit from the metal plate.

- 6) Reattach the metal attachment plate and the cooling filter cover to the PL.

Memo

Chapter

4 Installation and Wiring

1. Installation Cautions
2. Installing the PL
3. Wiring the PL

This chapter explains how to install and wire the PL-B910 series units, as well as the cautions required both before and during installation.

4.1 Installation Cautions

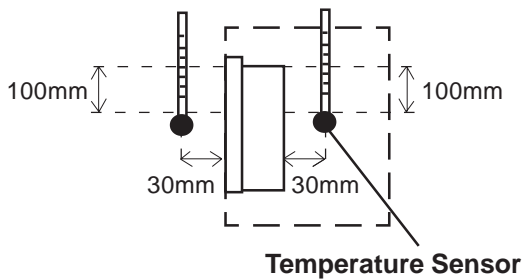

1) Temperature Related Cautions

- The PL should be installed in a vertical position, and forced air cooling should be used, instead of natural air circulation.
- To prevent a machine breakdown, be sure to use the PL within the allowable temperature range as below-listed. Please check “Ambient Operating Temperature” in the position drawn on the left (“Ambient Operating Temperature” indicates both the panel interior and panel face temperature.)

	Ambient Operating Temperature
W/ PL Fan	5°C to 50°C
W/OUT PL Fan	5°C to 40°C



2) Installation Positioning Cautions

Be sure to install the panel in an upright (vertical) position.

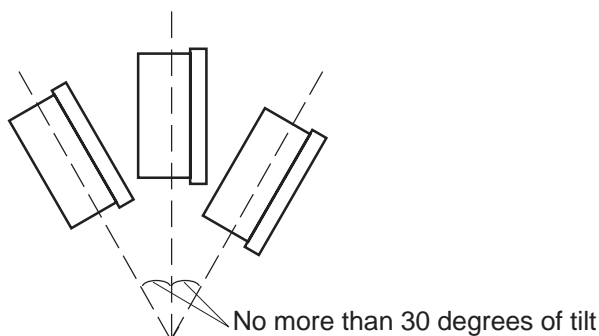

Also, be sure that the panel’s viewing angle is tilted no more than 30 degrees from parallel to the operator (i.e. directly in front).

■ **Installation Location**

- Avoid placing the PL next to other devices that might cause overheating.
- Keep the PL away from arc-generating devices such as magnetic switches and non-fuse breakers.
- Avoid using the PL in environments where corrosive gases are present.
- To ensure the reliability, operability and ventilation of the PL, be sure to install it in locations that are more than 50mm away from adjacent structures or equipment. Also, consider the need for installing or removing expansion boards, or connectors when designing and installing your PL.

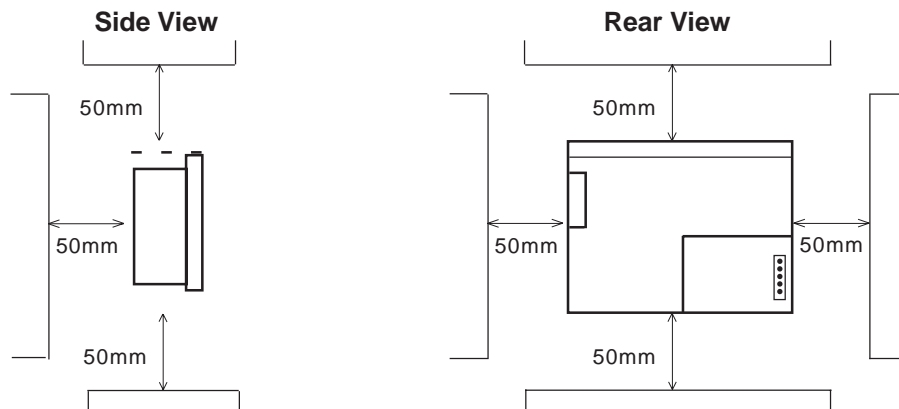

■ **Vibration and Shocks**

If the PL is moved when its enclosure doors are open, or while it is installed in a rack equipped with caster wheels, the hard disk can receive excessive vibration or jolting. Be especially careful at this time.

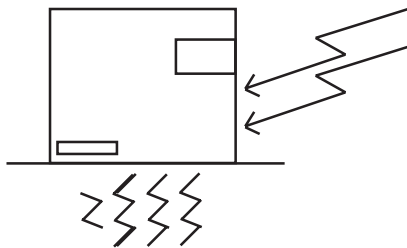

PL Configuration	Can Withstand
HDD	Up to 4.9m/s ²
FDD	Up to 9.8m/s ²
No drives	Up to 19.6m/s ²



- **The Hard Disk Drive is precision equipment and should not be moved or jolted . Especially when the PL is turned ON, even changing the PL’s direction while it is on a table, or repositioning the unit should not be performed, since it can lead to a hard disk crash or malfunction.**
- **When using a fan to cool the PL unit, be sure that the fan does not point directly at any of the PL’s disk drive units, since it can lead to a hard disk crash or malfunction.**

4.2 Installing the PL

4.2.1 Installation Procedures

Use the following procedures to install the PL into a solid panel.



Be sure to read the previous section's Installation Cautions in order to install the PL safely.



When using the optional 19 inch Mount Panel, refer to the PL-RM200 unit's Installation guide for details.

- 1) Use the six (6) attachment screws included in the PL's packing box to attach the mounting brackets to the PL main unit. Be careful that each bracket is attached to the correct side.

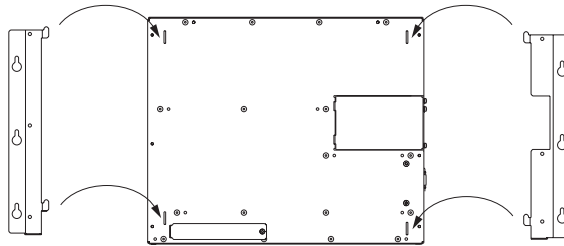

- 2) Drill the attachment holes in the Installation Panel. Be sure to follow the dimensions given for the attachment holes.

Reference 2.5.3 Full Sized Cover Attachment Dimensions

- 3) Attach the PL to the Installation Panel with M4 screws.

First, insert the main unit attachment screws into the Installation Panel's holes, but do not tighten them. Then, place the PL main unit on the panel so that the bracket holes and the screw heads align. Next, slide the PL down so that the main unit is supported by these attachment screws. Last, tighten the screws until the PL is secured in place.



Do not use excessive force when tightening the main unit attachment screws. The torque required is from 0.5 to 0.6N•m.

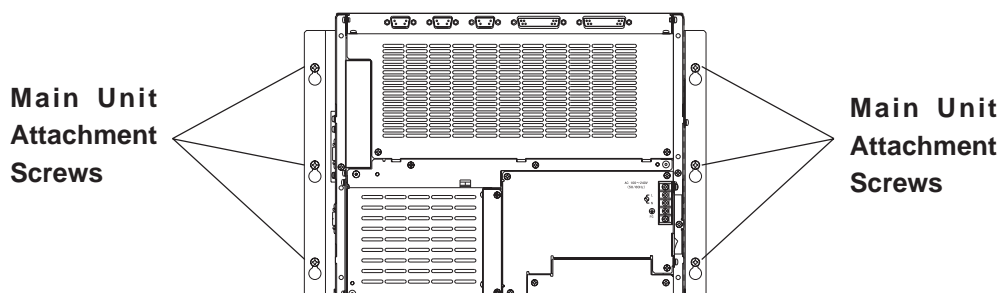

4.3 Wiring the PL

4.3.1 Connecting the Power Cord

Connect the PL's power cord to the PL's rear face power terminals.

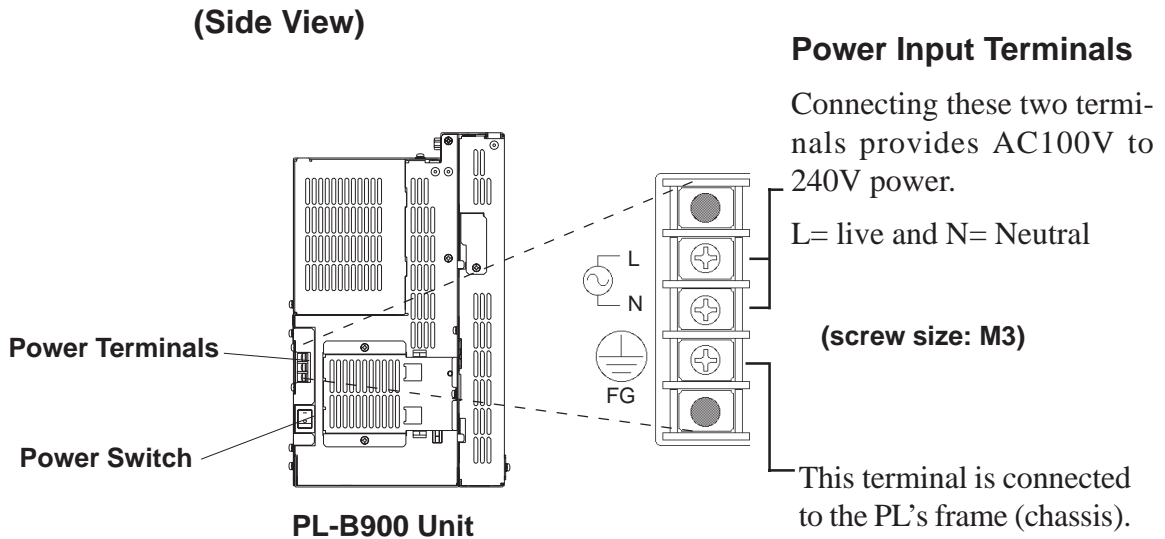

Use the following steps when connecting the power cord to the PL's power terminals.



WARNING

- To prevent electric shocks, be sure to turn the PL OFF before connecting the power cord terminals to the PL.
- To avoid the dangers of fire, electrical hazards and equipment damage, be sure to use only the specified power supply voltage when operating the PL.

POWER

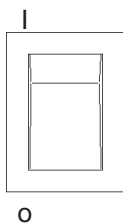

I:ON
o:OFF

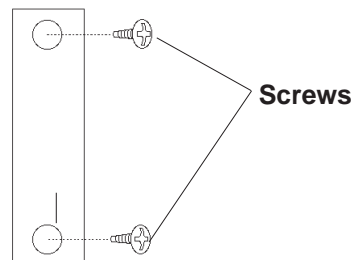
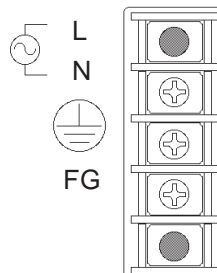

Transparent Cover

- 1) Confirm that the PL's power switch is turned OFF. Then, remove the power terminal's transparent plastic cover.

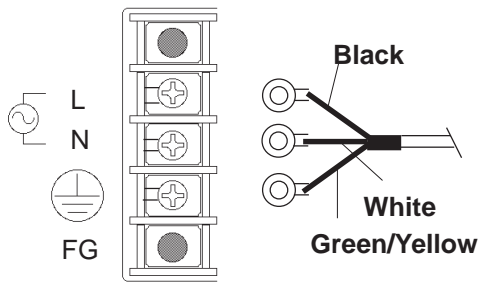

2) Loosen and remove the middle three screws from the terminal strip. Align the crimp terminals with each screw hole, and tighten the screws.



- Crimp Terminal Types : V1.25-3, by J.S.T. or equivalent (JIS standard part number : RAV1.25-3)

- Crimp terminals must be the same as shown below.

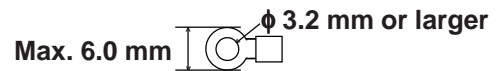

- **The colors used in these figures are for the cable which came with the PL.**
- **This power cable is designed only for AC100V/115V use. When using other than AC100V/115V power, use a cable that is designed specifically for that level of power.**

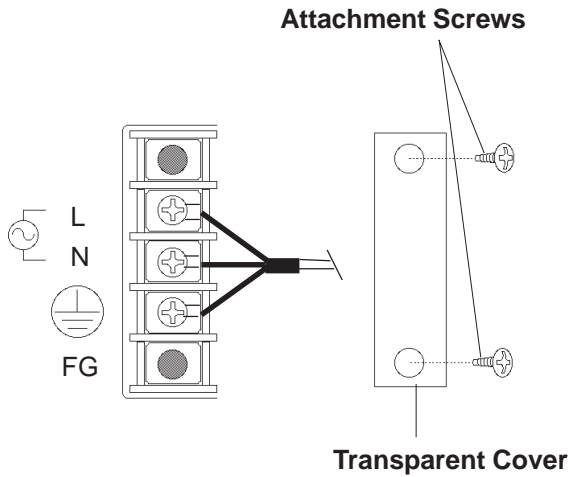

3) Reattach the terminal strip's transparent cover and secure it in place with its attachment screws.

4.3.2 Power Supply Cautions

When connecting the PL unit's AC power terminals, please be aware of the following:

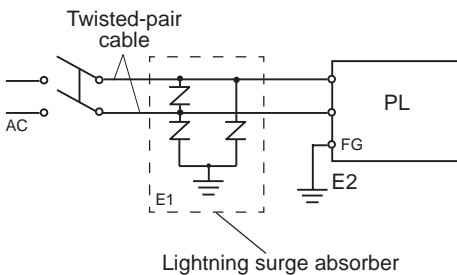
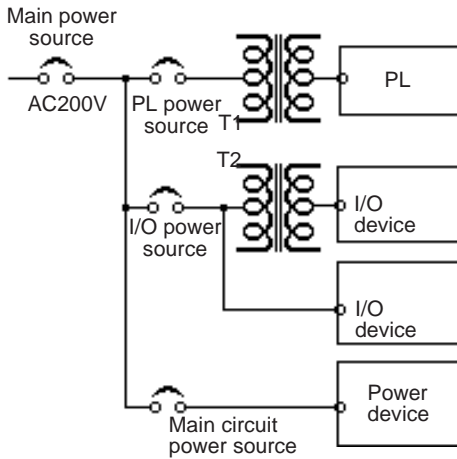
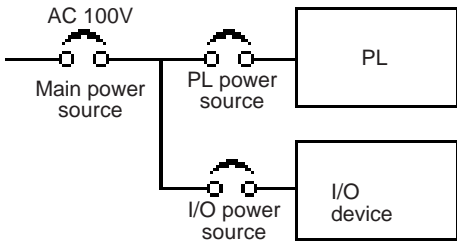
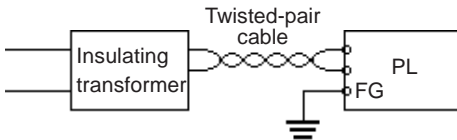
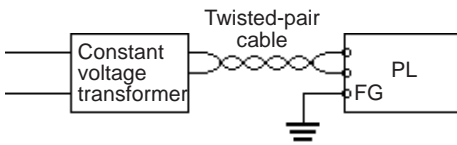

- If voltage fluctuations are expected to vary beyond the specified range, connect a constant voltage transformer.

Reference For information about the specified voltage, refer to **2.1 General Specifications**

- Use a low-noise power supply both between the lines and between the PL and its ground. If there is still excess noise, connect an insulating transformer (noise-prevention type).

Note: Be sure any constant or insulating transformer used has a capacity of 200VA or more.

- Wire the power cords of the PL, I/O devices, and power supply devices separately.

- To improve noise immunity, it is recommended to attach a ferrite core to the power cord.
- Isolate the main circuit (high voltage, large current) line, I/O signal lines, and power cord, and do not bind or group them together.

- To prevent damage from lightning, connect a lightning surge absorber.



• **Ground the lightning surge absorber (E1) and the PL (E2) separately.**

• **Select a lightning surge absorber which will not exceed the allowable circuit voltage, even when the voltage rises to the maximum.**

4.3.3 Grounding Cautions

(a) Dedicated Ground - best *1



- Set up a dedicated ground when using the rear panel's FG terminal.

(b) Shared Ground - allowed *1

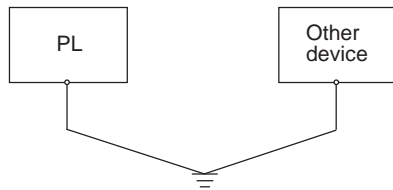

- If a dedicated ground is not possible, use a shared ground, as shown in figure (b).
- The grounding point must be as close to the PL as possible, and the grounding wires must be as short as possible. If the wires must be long, use thick, insulated wires and run them through conduits.

(c) Shared ground - not allowed

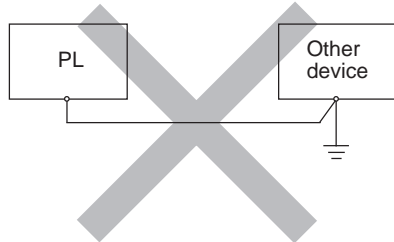

4.3.4 Cautions When Connecting I/O Signal Lines

- I/O signal lines must be wired separately from charged lines. If the power cord needs to be wired together with the (I/O) signal lines for any reason, use shielded lines and ground one end of the shield to the PL's FG terminal.
- To improve noise immunity, attaching a ferrite core to the power cord is recommended.

*1 Use a grounding resistance of less than 100 Ω and a 2mm² or thicker wire, or your country's applicable standard. For details, contact your local PL distributor.

Memo

Chapter

5 System Setup

(When the factory settings are for RS-422)

1. Setup Procedures
2. System Parameters

5.1 Setup Procedures

This chapter explains how to enter a PL unit's system settings, as well as the cautions required both before and during set up.



Note: The following settings are those pre-set at the factory.

- 1) Attach the PL and its DU unit or an RGB monitor.
- 2) Connect a PS/2 keyboard to the PL.
- 3) Turn the PL, and the DU or the Analog monitor's power ON.
- 4) After the message "Press to Enter SETUP" appears, press the [DEL] key until the following screen is displayed.

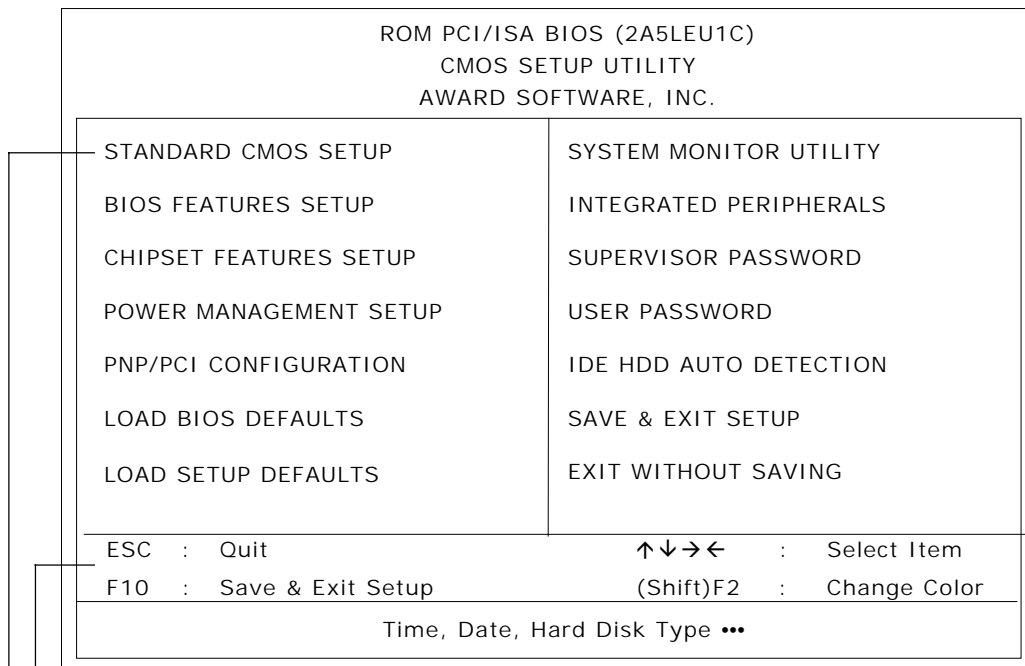

KEYBOARD ACTION KEYS

Provides a summary of the keyboard keys used to carry out the set up.

SYSTEM SETTING SELECTION AREA

Each of the titles (areas) listed here contains system setting items.

- 5) Use the arrow keys to move the cursor to the desired selection and use the [Enter] key to select an item.

5.2 System Parameters

Use the menu screen to select a System Item, and then enter the desired system information. Each item's detailed settings are shown here.



Normally, use only the factory (default) settings.

5.2.1 STANDARD CMOS SETUP

Selecting the STANDARD CMOS SETUP menu item produces the following screen.

ROM PCI/ISA BIOS(2A5LEU1C)							
STANDARD CMOS SETUP							
AWARD SOFTWARE, INC.							
Date (mm:dd:yy): Thu, Jul 2 2000							
Time (hh:mm:ss): 14 : 50 : 3							
		CYLS.	HEADS	PRECOMP	LANDZONE	SECTORS MODE	
Drive C	:Auto(0Mb)	0	0	0	0	0 AUTO	
Drive D	:Auto(0Mb)	0	0	0	0	0 AUTO	
Drive A	:1.44M,3.5 in.						
Video :	EGA/VGA						
VGA Text Mode :	Normal						
VGA Graphics Mode :	Normal						
Halt On :	All, But Disk/Key						
ESC :	Quit	↑↓→←	:	Select Item	PU/PD/+/-	:	Modify
F1 :	Help	(Shift)F2	:	Change Color			
				Base Memory	:	640K	
				Extended Memory	:	645612K	
				Other Memory	:	384K	
				Total Memory	:	66536K	

** The above settings are factory settings.*

■ Date/Time

This data sets the PL's internal time and date.

Hours :00 - 23

Minutes :00 - 59

Seconds :00 - 59

■ Drive C

This data sets the IDE hard disk's parameters. When this setting is set to [AUTO], the hard disk's parameters are automatically read in. Also, if the "IDE HDD AUTO DETECTION" is in use, the value entered there is automatically set. The three options are [User],[Auto], and [None]. The [Auto] setting is factory set and recommended for most users.

■ Drive D

The three options are [User],[None]and [Auto].

■ Drive A

This setting determines the format used by the PL's internal floppy disk drive. The[1.44M - 3.5in] selection is factory set and recommended for most users. The other available settings are [720K - 3.5in], [1.2M - 5.25in], [360K - 5.25in], [2.88M - 3.5in.], and [None].

■ Video

The selections for the screen (video) mode. The [EGA/VGA] selection is factory set and recommended for most users. The other available settings are [CGA40], [CGA80] and [Mono].

■ VGA Text Mode

This mode changes the screen (video) mode from [Normal](VGA mode) to [Expansion](800x600). The [Normal] selection is factory set and recommended for most users.

■ VGA Graphics Mode

This mode changes the screen (Graphics) mode from [Normal](VGA mode) to [Expansion](800x600). The [Normal] selection is factory set and recommended for most users.

■ Halt On

Designates the type of processing that will be performed when an error occurs during the Initial Start-Up Self Test. The [All But Disk /Key] selection is factory set and recommended for most users.

[All Errors] : Displays all errors and stops the unit.

[No Errors] : Displays all errors and does not stop the unit.

[All,But Keyboard]: Displays all errors, except for those related to the keyboard, and stops the unit. If the User has no keyboard connected, please use this setting.

[All,But Diskette]: Displays all errors, except for those related to the disk drive (FDD), and stops the unit.

[All,But Disk/Key]: Displays all errors, except for those related to the disk drive (FDD) and keyboard, and then stops the unit.

5.2.2 BIOS FEATURES SETUP

Selecting the BIOS FEATURES SETUP menu item calls up the following screen.

ROM PCI/ISA BIOS(2A5LEU1C)	
BIOS FEATURES SETUP	
AWARD SOFTWARE, INC.	
Virus Warning	: Disabled
CPU Internal Cache	: Enabled
External Cache	: Enabled
Quick Power On Self Test	: Enabled
Boot Sequence	: A,C,SCSI
Boot Up Floppy Seek	: Enabled
Boot Up NumLock Status	: On
Boot Up System Speed	: High
Gate A20 Option	: Fast
Memory Parity/ECC Check	: Enabled
Typematic Rate Setting	: Disabled
Typematic Rate(Chars/Sec)	: 6
Typematic Delay (Msec)	: 250
Security Option	: Setup
PCI/VGA Palette Snoop	: Disabled
OS Select For DRAM > 64MB	: Non-OS2
Video BIOS Shadow	: Enabled
C8000-CBFFF Shadow	: Disabled
CC000-CFFFF Shadow	: Disabled
D0000-D3FFF Shadow	: Disabled
D4000-D7FFF Shadow	: Disabled
D8000-DBFFF Shadow	: Disabled
DC000-DFFFF Shadow	: Disabled
ESC : Quit ↑ ↓ → ← : Select Item	
F1 : Help PU/PD/+/- : Modify	
F5 : Old Values (Shift)F2 : Color	
F6 : Load BIOS Defaults	
F7 : Load Setup Defaults	

** The above settings are factory settings.*

■ Virus Warning

Designates whether a warning message appears when an error occurs during a write to the Hard Disk's Boot Sector. The two selections are [Disabled] and [Enabled]. The [Disabled] selection is factory set and recommended for most users.

■ CPU Internal Cache

Designates if the CPU's Internal Cache Memory is used or not. The two selections available are [Disabled] and [Enabled]. The [Enabled] selection is factory set and recommended for most users.

■ External Cache

Designates if the CPU's External Cache Memory (L2) is used or not. The two selections available are [Disabled] and [Enabled]. The [Enabled] selection is factory set and recommended for most users.

■ Quick Power On Self Test

Designates if a simplified Self Test is used after the power is turned ON. The two selections available are [Disabled] and [Enabled]. The [Enabled] selection is factory set and recommended for most users.

■ Boot Sequence

Designates the drive order used by the OS during start up.

The [A,C,SCSI] is factory set and recommended for most users. The other available settings are [A,C,SCSI], [C,A,SCSI], [C,CDROM,A], [CDROM,C,A], [D,A,SCSI], [SCSI, A,C,], [SCSI,C,A] and [C Only].

■ Boot Up Floppy Seek

Designates if the floppy disk drive installation check is used or not. The available selections are [Disabled] and [Enabled]. [Enabled] is factory set and recommended for most users.

■ Boot Up NumLock Status

Designates the condition of the NumLock key at startup. The two selections are either [On] or [Off]. The [On] selection is factory set and recommended for most users.

■ Boot Up System Speed

Designates the speed of CPU. [High] is factory set and recommended for most users. The other available selection is [Low].

■ Gate A20 Option

The two selections available are [Fast] and [Normal]. When [Normal] is selected, Keyboard Control is used for Gate A20 control. When [Fast] is selected, the Chipset is used. The [Fast] selection is factory set and recommended for most users.

■ Memory Parity / ECC Check

Designates if a Parity Check is used for Parity Memory. The two selections available are [Disabled] and [Enabled]. The [Enabled] selection is factory set and recommended for most users.

■ Typematic Rate Setting

Designates the repeat mode for characters on the keyboard. The selections [Disabled] and [Enabled] are available. [Disabled] is factory set and recommended for most users.

■ Typematic Rate (Chars/Sec)

When [Enabled] is selected on [Typematic Rate Setting], it designates the actual rate (the number of repeating characters per second). [6],[8],[10],[12],[15], [20],[24] and [30] are the available selections.[6] is factory set.

■ Typematic Delay (Msec)

When [Enabled] is selected on [Typematic Rate Setting], this setting designates the delay period until repetition of a character starts. The unit is millisecond (msec). The available selections are [250],[500],[750]and [1000]. [250] is factory set.

■ Security Option

Designates the location of the Password Entry. The selection [Setup] is for BIOS setup, and the other selection [System] is for both BIOS setup and Start up. When the [Supervisor Password] or [User Password] has not been designated, this setting is disabled. [Setup] is factory set and recommended for most users.



Note:

Choose either the "Supervisor Password" or the "User Password" from the Password menu.

■ PCI/VGA Palette Snoop

When the PCI/VGA and the MPEG ISA/VESA VAG cards are both used, this setting is set to [Enabled]. In all other cases, this should be set to [Disabled]. The [Disabled] selection is factory set and recommended for most users.

■ **OS Select For DRAM >64MB**

Select either [Non-OS2] or [OS2]. The [Non-OS2] selection is factory set and recommended for most users.

■ **Video BIOS Shadow**

Designates whether Video BIOS ROM is expanded into RAM and used from there (C0000-C7FFF). The two selections available are [Disabled] and [Enabled]. The [Enabled] selection is factory set and recommended for most users.

■ **C8000-CBFFF Shadow to DC000-DFFFF Shadow**

When the Expansion Board's ROM is placed in this area, this setting designates if the ROM expands into the RAM area. The two available selections are [Disabled] and [Enabled]. The [Disabled] selection is factory set and recommended for most users.

5.2.3 CHIPSET FEATURES SETUP

Selecting the CHIPSET FEATURES SETUP menu item calls up the following screen.

ROM PCI/ISA BIOS(2A5LEU1C) CHOS SETUP UTILITY CHIPSET FEATURES SETUP	
Bank 0/1 DRAM Timing : 70ns SDRAM Cycle Length : 3 DRAM Read Pipeline : Enabled Sustained 3T Write : Enabled Cache Rd+CPU Wt Pipeline : Enabled Cache Timing : Fast Video BIOS Cacheable : Enabled System BIOS Cacheable : Enabled Memory Hole At 15Mb Addr. : Disabled	OnChip USB : Disabled <hr/> ESC : Quit ↑ ↓ → ← : Select Item F1 : Help PU/PD/+/- : Modify F5 : Old Values (Shift)F2 : Color F6 : Load BIOS Defaults F7 : Load Setup Defaults

** The above settings are factory settings.*

■ **Bank 0/1 DRAM Timing**

Designates the length of time of accessing to the memory set up on the memory slot 0/1. The available selections are [70ns], [60ns], [Normal], [Medium], [Fast] and [Turbo]. [70ns] is factory set and recommended for most users.

■ SDRAM Cycle Length

Designates the length of the cycle time of SDRAM. The available selections are [3] and [2]. [3] is factory set and recommended for most users.

■ DRAM Read Pipeline

Designates if the DRAM performs the pipeline read. The available selections are [Enabled] and [Disabled], [Enabled] is factory set and recommended for most users.

■ Sustained 3T Write

Designates if the DRAM performs the write back and the write through in the secondary cache. The available selections are [Enabled] and [Disabled]. [Enabled] is factory set and recommended for most users.

■ Cache Rd+CPU Wt Pipeline

Designates the length of time of waiting for the cache performance. The available selections are [Enabled] and [Disabled]. [Enabled] is factory set and recommended for most users.

■ Cache Timing

Designates the access speed of the cache. The available selections are [Fast] and [Fastest]. [Fast] is factory set and recommended for most users.

■ Video BIOS Cacheable

Designates if the cache performs on the Video BIOS. The available selections are [Enabled] and [Disabled]. [Enabled] is factory set and recommended for most users.

■ System BIOS Cacheable

Designates if the cache performs on the System BIOS. Using System BIOS speeds up the program operation. The available selections are [Enabled] and [Disabled]. [Enabled] is factory set and recommended for most users.

■ Memory Hole At 15Mb Addr.

Designates if the memory hole 15MB to 16MB is allocated to the buffer memory for the ISA bus card. The available selections are [15M-16M] and [Disabled]. [Disabled] is factory set and recommended for most users.

■ On Chip USB

Used for USB type peripheral equipment. The available selections are [Enabled] and [Disabled]. Select [Enabled] for Touch Panel's connection using a USB cable.

■ USB Keyboard Support



If the "On Chip USB" selection is [Enabled], select [Disabled].

5.2.4 POWER MANAGEMENT SETUP

Selecting the POWER MANAGEMENT SETUP menu item calls up the following screen.

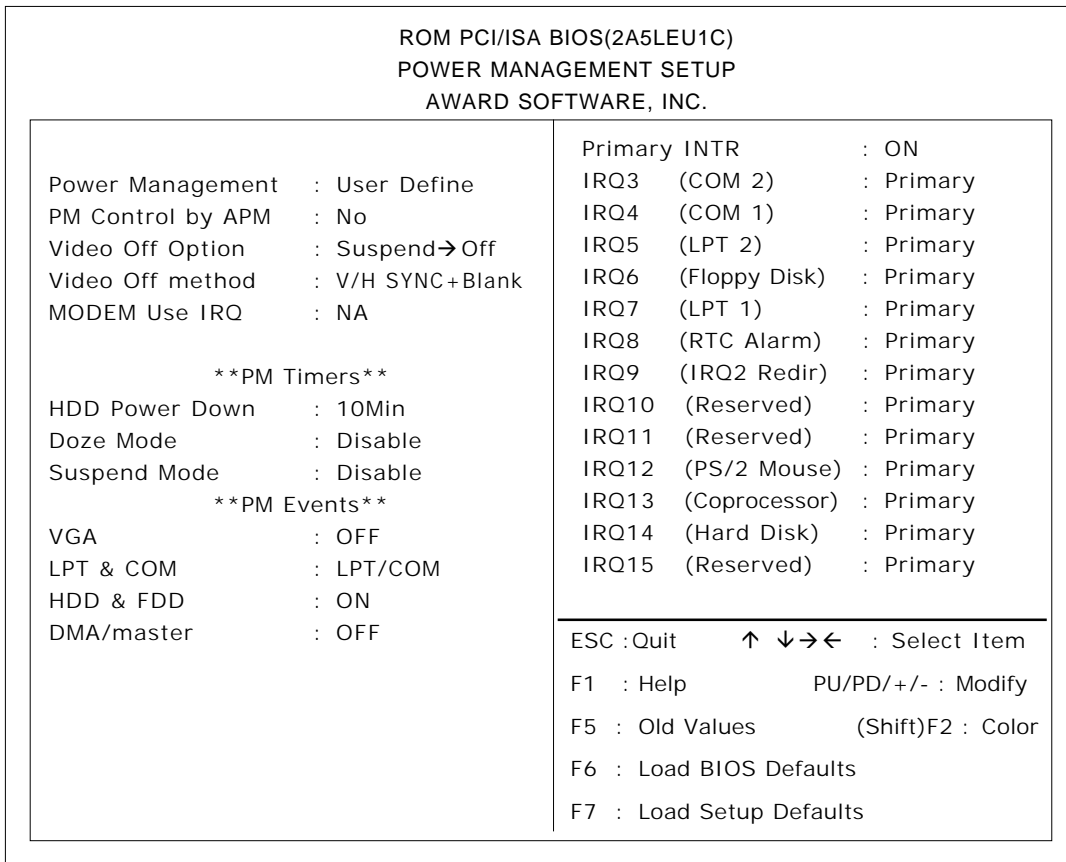

** The above settings are factory settings.*

■ **Power Management**

You can choose from three power management options. These are [User Define], [Min Saving] and [Max Saving]. The [User Define] selection is factory set and recommended for most users.

■ **PM Control by APM**

Designates if the power management is controlled by the APM. The two selections available are [Yes] and [No]. The [No] selection is factory set and recommended for most users.

■ **Video Off Option**

Turns the display off. The selections are [Always On], [SuspendàOff], and [All ModesàOff]. [SuspendàOff] is factory set and recommended for most users.

■ **Video Off Method**

Designates the method of turning the display off. The available selections are [V/H SYNC+Blank], [Blank Screen] and [DPMS Support]. To turn off both the display and the Vertical / Horizontal synchronous signal, select [V/H SYNC+Blank]. To turn off the display only, select [Blank Screen]. Select [DPMS support] when the CRT display is supported by DPMS. [V/H SYNC+Blank] is factory set and recommended for most users.

■ **MODEM Use IRQ**

Selections for this feature include [NA],[3],[4],[5],[7],[9][10], and [11]. The [NA] selection is factory set and recommended for most users.

■ **HDD Power Down**

Designates the length of time until the motor of the hard disk stops. The available selections are [1Min]à[15Min] and [Disabled]. [10Min] is factory set and recommended for most users.

■ **Doze Mode**

When there is no reply from the system within designated time, the CPU is automatically stopped. [Disable] is factory set and recommended for most users.

■ **Suspend Mode**

When there is no reply from the system within designated time, by using this mode all peripheral equipment operation will be stopped. [Disable] is factory set and recommended for most users.

■ **VGA**

Designates if the system is turned on when any event is driven in the VGA port. The available selections are [ON] and [OFF]. [OFF] is factory set and recommended for most users.

■ **LPT & COM**

Designates if the system is turned on when any event is driven in the serial port or the printerport. The available selections are [None], [LPT], [COM] and [LPT / COM]. [LPT/COM] is factory set and recommended for most users.

■ **HDD & FDD**

Designates if the system is turned on when any event is driven in the hard disk or floppy disk. The available selections are [ON] and [OFF]. [ON] is factory set and recommended for most users.

■ **DMA / master**

Designates if the system is turned on when any event is driven in the DMA controller. The available selections are [ON] and [OFF]. [OFF] is factory set and recommended for most users.

■ **Primary INTR**

Designates if the system is turned on when any event is driven in the Primary Interrupt Controller. The available selections are [ON] and [OFF]. [ON] is factory set and recommended for most users.

■ **IRQ3-IRQ15**

Designates if the COM Port is monitored or not. The available selections are [Disabled], [Primary] and [Secondary].

5. 2. 5 PNP/PCI CONFIGURATION SETUP

Selecting the PNP/PCI CONFIGURATION SETUP menu item displays the following screen.

ROM PCI/ISA BIOS(2A5LEU1C)	
PNP/PCI CONFIGURATION	
AWARD SOFTWARE, INC.	
PNP OS Installed	: No
Resources Controlled By	: Manual
Reset Configuration Data	: Disabled
ACPI I/O Device Node	: Enabled
IRQ-3 assigned to	: Legacy ISA
IRQ-4 assigned to	: Legacy ISA
IRQ-5 assigned to	: PCI/ISA PnP
IRQ-7 assigned to	: Legacy ISA
IRQ-9 assigned to	: Legacy ISA
IRQ-10 assigned to	: Legacy ISA
IRQ-11 assigned to	: PCI/ISA PnP
IRQ-12 assigned to	: Legacy ISA
IRQ-14 assigned to	: Legacy ISA
IRQ-15 assigned to	: PCI/ISA PnP
DMA-0 assigned to	: PCI/ISA PnP
DMA-1 assigned to	: PCI/ISA PnP
DMA-3 assigned to	: PCI/ISA PnP
DMA-5 assigned to	: PCI/ISA PnP
DMA-6 assigned to	: PCI/ISA PnP
DMA-7 assigned to	: PCI/ISA PnP
CPU to PCI Write Buffer	: Enabled
PCI Dynamic Bursting	: Enabled
PCI Master 0 WS Write	: Enabled
PCI Delay Transaction	: Enabled
PCI Master Read Prefetch	: Enabled
PCI#2 Access #1 Retry	: Disabled
PCI IRQ Activated By	: Level
Assign IRQ For USB	: Disabled
ESC: Quit	↑↓→← :Select Item
F1 : Help	PU/PD/+/-:Modify
F5 : Old Values	(Shift)F2:Color
F6 : Load BIOS Defaults	
F7 : Load Setup Defaults	

** The above settings are factory settings.*

■ PNP OS Installed

Setting used when the user's OS complies with Plug-And-Play standards. The selection options are either [Yes] or [No]. The [No] setting is factory set and recommended for most users.

■ Resources Controlled By

The Plug and Play feature allows you to designate whether the allocation of I/O Port, IRQ and DMA resources is performed automatically or manually. The two selections available are [Manual] and [Auto]. The [Manual] selection is factory set and recommended for most users.

■ Reset Configuration Data

Designates whether ESCD (Extended System Configuration Data) data should be erased or not. The two selections available are [Disabled] and [Enabled]. The [Disabled] selection is factory set and recommended for most users.

■ ACPI I/O Device Node

When an I/O device is connected to the PL that is ACPI compliant, the PL's ACPI feature is enabled. The two selections available are [Enabled] and [Disabled]. The [Enabled] selection is factory set and recommended for most users.

■IRQ-3 assigned to - IRQ-15 assigned to

Only after the "Resources Controlled By" setting is set to [Manual] can the following IRQ-3assigned to - IRQ-15assigned to settings be changed. These settings are used for the [PCI/ISA PnP] and [Legacy ISA] items.

[PCI/ISA PnP] :Used for PCI or ISA's PnP Card

[Legacy ISA] :Used for ISA Cards that do not comply with PnP

	INITIAL SETTING		INITIAL SETTING
IRQ-3 assigned to	Legacy ISA	IRQ-10 assigned to	Legacy ISA
IRQ-4 assigned to	Legacy ISA	IRQ-11 assigned to	PCI/ISA PnP
IRQ-5 assigned to	PCI/ISA PnP	IRQ-12 assigned to	Legacy ISA
IRQ-7 assigned to	Legacy ISA	IRQ-14 assigned to	Legacy ISA
IRQ-9 assigned to	Legacy ISA	IRQ-15 assigned to	PCI/ISA PnP

■DMA-0 assigned to - DMA-7 assigned to

Only after the "Resources Controlled By" setting is set to [Manual] can the following DMA-0 assigned to - DMA-7 assigned to settings be changed. These settings are used for the [PCI/ISA PnP] and [Legacy ISA] items.

[PCI/ISA PnP] : Used for PCI or ISA's PnP Card

[Legacy ISA] : Used for ISA Cards that do not comply with PnP

	INITIAL SETTING		INITIAL SETTING
DMA-0 assigned to	PCI/ISA PnP	DMA-5 assigned to	PCI/ISA PnP
DMA-1 assigned to	PCI/ISA PnP	DMA-6 assigned to	PCI/ISA PnP
DMA-3 assigned to	PCI/ISA PnP	DMA-7 assigned to	PCI/ISA PnP

■CPU to PCI Write Buffer

Setting for the PCI Write Buffer. If [Disabled] is selected, it becomes the CPU's Read Cycle [Enable] or [Disable] toggle. The [Enabled] selection is factory set and recommended for most users.

■PCI Dynamic Bursting

Setting for the PCI's Burst Transmission. The available settings are [Enable] and [Disable]. [Enabled] is factory set and recommended for most users.

■PCI Master 0 WS Write

Sets the duration of the wait for the writing to the PCI Bus to "0". [Enabled] and [Disabled] are available. The [Enabled] setting is factory set and recommended for most users.

■PCI Delay Transaction

This feature enables or disables the Chip Set's PCI Delay Transaction Cycle's built in 32Bit Posted Buffer support. [Enabled] and [Disabled] are available. The [Enabled] setting is factory set and recommended for most users.

■PCI Master Read Prefetch

Enables or disables the PCI Master Read Prefetch feature.[Enabled] and [Disabled] are available. The [Enabled] setting is factory set and recommended for most users.

■PCI #2 Access #1 Retry

Enables or disables the PCI "2 Access #1 Retry feature. [Enabled] and [Disabled] are available. The [Disabled] setting is factory set and recommended for most users.

■ PCI IRQ Activated by

Designates the interrupt method used for the unit's PCI slots. [Level] or [Edge] can be used. [Level] is factory set and recommended for most users.

■ Assign IRQ For USB

Designates if the interrupt is allocated for USB equipment or not. [Enabled] and [Disabled] are available. Select [Enabled] for Touch Panel's connection using a USB cable.

5. 2. 6 LOAD BIOS DEFAULTS

Selecting "LOAD BIOS DEFAULTS" calls up the menu used to enter the minimum level system settings. It is normally not used.

5. 2. 7 LOAD SETUP DEFAULTS

When selecting "Load Setup Default" from the menu, the factory-set system settings (for a RS-422 connection) will be loaded.

With Touch Panel's connection using a USB cable, after selecting "Load Setup Default", be sure to change the following settings to revert the unit to the original factory settings.

System Information Menu	Setting Items	USB Settings
CHIPSET FEATURES SETUP	On Chip USB	Enabled
PNP/PCI CONFIGURATION	Assign IRQ For USB	Enabled
INTEGRATED PERIPHERALS	IDE Primary Master UDMA	Disabled
	IDE Primary Slave UDMA	
	Onboard Serial Port 4	

5. 2. 8 SYSTEM MONITOR UTILITY

Selecting SYSTEM MONITOR UTILITY menu item displays the following screen.

ROM PCI/ISA BIOS(2A5LEU1C) SYSTEM MONITOR UTILITY AWARD SOFTWARE, INC.	
CPU Warning Temperature : Disabled	
System Warning Temp. : Disabled	
Power FAN : Tolerance : Disabled	
CPU FAN : Tolerance : Disabled	
IN0(Vcore) : Tolerance : Disabled	
IN2(3.3V) : Tolerance : Disabled	
IN3(5V) : Tolerance : Disabled	
IN4(12V) : Tolerance : Disabled	
IN5(-12V) : Tolerance : Disabled	
IN6(-5V) : Tolerance : Disabled	
	ESC: Quit ↑↓→← : Select Item
	F1 : Help PU/PD/+/-: Modify
	F5 : Old Values (Shift)F2: Color
	F6 : Load BIOS Defaults
	F7 : Load Setup Defaults

* The above settings are factory settings.

■ CPU Warning Temperature

Sets the temperature level that will trigger a CPU overheating alarm. Ten selections are available - [Disabled], [40°C/104°F], [45°C/113°F], [50°C/122°F], [55°C/131°F], [60°C/140°F], [65°C/149°F], [70°C/158°F], [75°C/167°F], [80°C/176°F].

The [Disabled] selection is factory set and recommended for most users.

■ System Warning Temp

Sets the temperature level where a motherboard overheating alarm is triggered. Ten selections are available - [Disabled], [40°C/104°F], [45°C/113°F], [50°C/122°F], [55°C/131°F], [60°C/140°F], [65°C/149°F], [70°C/158°F], [75°C/167°F], [80°C/176°F]. The [Disabled] selection is factory set and recommended for most users.

■ Power FAN

Sets the allowable range for the PL's power supply fan. [Disabled], [+/-30%] and [+/-50%] are available. The [Disabled] selection is factory set and recommended for most users.

■ CPU FAN

Sets the allowable range for the PL's power supply fan. [Disabled], [+/-30%] and [+/-50%] are available. The [Disabled] selection is factory set and recommended for most users.

■ INO(Vcore)

Sets the allowable range for the INO(Vcore) voltage. [Disabled], [+/-4%] and [+/-6%] are available. The [Disabled] selection is factory set and recommended for most users.

■ IN2(3.3V)

Sets the allowable range for the IN2(3.3V) voltage. [Disabled], [+/-4%] and [+/-6%] are available. The [Disabled] selection is factory set and recommended for most users.

■ IN3(5V)

Sets the allowable range for the IN3(5V) voltage. [Disabled], [+/-4%] and [+/-6%] are available. The [Disabled] selection is factory set and recommended for most users.

■ IN4(12V)

Sets the allowable range for the IN4(12V) voltage. [Disabled], [+/-4%] and [+/-6%] are available. The [Disabled] selection is factory set and recommended for most users.

■ IN5(-12V)

Sets the allowable range for the IN5(-12V) voltage. [Disabled], [+/-4%] and [+/-6%] are available. The [Disabled] selection is factory set and recommended for most users.

■ IN6(-5V)

Sets the allowable range for the IN6(-5V) voltage. [Disabled], [+/-4%] and [+/-6%] are available. The [Disabled] selection is factory set and recommended for most users.

5. 2. 9 INTEGRATED PERIPHERALS

Selecting INTEGRATED PERIPHERALS SETUP menu item displays the following screen.

ROM PCI/ISA BIOS(2A5LEU1C)	
INTEGRATED PERIPHERALS	
AWARD SOFTWARE, INC.	
OnChip IDE First Channel	: Enabled
IDE Prefetch Mode	: Disabled
IDE HDD Block Mode	: Disabled
IDE Primary Master PIO	: Auto
IDE Primary Slave PIO	: Auto
IDE Primary Master UDMA	: Auto
IDE Primary Slave UDMA	: Auto
Onboard FDC Controller	: Enabled
Onboard Serial Port 1	: 3F8/IRQ4
Onboard Serial Port 2	: 2F8/IRQ3
UR2 Mode	: Standard
Onboard Parallel Port	: 3BC/IRQ7
Parallel Port Mode	: SPP
Onboard Serial Port 3	: 3E8H
Serial Port 3 Use IRQ	: IRQ9
Onboard Serial Port 4	: 2E8H
Serial Port 4 Use IRQ	: IRQ10
ESC: Quit ↑↓→← : Select Item F1 : Help PU/PD/+/-: Modify F5 : Old Values (Shift)F2: Color F6 : Load BIOS Defaults F7 : Load Setup Defaults	

** The above settings are factory settings.*

■ OnChip IDE First Channel

Designates the internal IDE port's setting. The two selections available are [Disabled] and [Enabled]. The [Enabled] selection is factory set and recommended for most users.

■ IDE Prefetch Mode

Designates if the IDE drive's high speed access is performed by enabling the Prefetch Mode. The two selections available are [Disabled] and [Enabled]. The [Disabled] selection is factory set and recommended for most users.

■ IDE HDD Block Mode

Designates the Hard disk's Block Operation Mode. The two selections available are [Disabled] and [Enabled]. The [Disabled] selection is factory set and recommended for most users.

■ IDE Primary Master PIO

Designates the Master Drive's PIO (Programmed Input/Output Mode. Only after the "Internal PCI/IDE" has been set to [Primary] can these IDE Primary Master PIO settings be entered. The selections available are [Auto], [Mode0], [Mode1], [Mode2], [Mode3], and [Mode4]. When using the CD-ROM unit, set this to "Mode 2".

■IDE Primary Slave PIO

Designates the Slave Drive's Operation Mode. Only after the "Internal PCI/IDE" has been set to [Primary] can these IDE Primary Slave PIO settings be entered. The selections available are [Auto], [Mode0], [Mode1], [Mode2], [Mode3], and [Mode4]. When using the CD-ROM unit, set this to "Mode 2".

■IDE Primary Master UDMA

Designates the Master Drive's UDMA Operation Mode. The two selections available are [Auto] or [Disabled]. When using the CD-ROM unit, and using a USB cable for Touch Panel connection, set this to [Disabled].

■IDE Primary Slave UDMA

Designates the Slave Drive's UDMA Operation Mode. The two selections available are [Auto] or [Disabled]. When using the CD-ROM unit, and using a USB cable for Touch Panel connection, set this to [Disabled].

■Onboard FDC Controller

Designates whether the PL's FDD(Floppy Disk Drive) controller is used or not. The two selections available are [Disabled] or [Enabled]. The [Enabled] selection is factory set and recommended for most users.

■Onboard Serial Port1

Designates the PL's Serial Port1 address setting. The selections include [Disabled], [Auto], [3F8/IRQ4], [2F8/IRQ3], [3E8/IRQ4] or [2E8/IRQ3]. The [3F8/IRQ4] selection is factory set and recommended for most users.

■Onboard Serial Port2

Designates the PL's Serial Port2 address setting. The selections include [Disabled], [Auto], [3F8/IRQ4], [2F8/IRQ3], [3E8/IRQ4] or [2E8/IRQ3]. The [2F8/IRQ3] selection is factory set and recommended for most users.

■UR2 Mode

Designates the IR function used by the PL's onboard I/O chip. The selections include [Standard], [Sharp IR], [IrDA SIR]. The [Standard] selection is factory set and recommended for most users. When serial port 2 is used for RS-232C communication, and the [standard] option's PL-IR100 selection is used, set this item to [IrDA/SIR].

■Onboard Parallel Port

Selects the PL Parallel Port 1's I/O Address. The selections include [Disabled], [3BC/IRQ7], [378/IRQ7] or [278/IRQ5]. The [3BC/IRQ7] selection is factory set and recommended for most users.

■Parallel Port Mode

Here, the parallel port's operation mode can be selected ([SPP], [EPP1.7], [EPP1.9], [ECP], or [ECP + EPP]). Normally, [SPP] is used and recommended for most users. When either [ECP] or [ECP+EPP] is selected, the [ECP Mode Use DMA] setting can be used.

■ECP Mode Use DMA

Designates the ECP mode's DMA channel. [1] and [3] are available selections, however, this item can be set only when the Parallel Port Mode is set to either [ECP] or [ECP+EPP].

Chapter 5 - System Setup

■ Onboard Serial Port 3

Designates the PL's Serial port 3 address setting. The selections include [Disabled], [3F8H], [2F8H], [3E8H], or [2E8H]. The [3E8H] selection is factory set and recommended for most users.

■ Serial Port 3 Use IRQ

Designates the PL's Serial Port 4 allocation numbers. The selections include [IRQ3], [IRQ4], [IRQ9], [IRQ10], or [IRQ15].

■ Onboard Serial Port 4

Designates the PL's Serial Port 4, which is internally connected to the touch panel, address setting. The selections include [Disabled], [3F8H], [2F8H], [3E8H], or [2E8H]. The [2E8H] selection is factory set and recommended for most users.

For using a USB cable for Touch Panel connection, set this to [Disabled].

■ Serial Port 4 Use IRQ

Designates the PL's Serial Port 4 allocation numbers. The selections include [IRQ3], [IRQ4], [IRQ9], [IRQ10], or [IRQ15]. The [IRQ10] selection is factory set and recommended for most users.

5. 2. 10 IDE HDD AUTO DETECTION

Selecting the IDE HDD AUTO DETECTION menu item produces the following screen.

Provides automatic detection of any hard disk connected to the IDE. Normally unused.

```

ROM PCI/ISA BIOS(2A511U1C)
  CMOS SETUP UTILITY
  AWARD SOFTWARE, INC.
  
```

```

          CYLS.  HEADS  PRECOMP  LANDZONE  SECT0RS  MODE
Drive C  :  ( Mb)
  
```

```

          Select Drive C Option(N=Skip) : N
  
```

OPTIONS	SIZE	CYLS.	HEADS	PRECOMP	LANDZONE	SECTORS	MODE
2(Y)	2167	525	128	0	4199	63	LBA
1	2167	4200	16	65535	4199	63	NORMAL
3	2167	525	128	65535	4199	63	LARGE

```

Note   :  Some OSes (like SCO-UNIX) must use "NORMAL" for Installation
  
```

```

ESC:Skip
  
```

** The above settings are factory settings.*

Memo

Chapter

6 OS Setup

This chapter provides information about the set up of the PL's Windows® 95, Windows® 98 Second Edition, or Windows NT® operating systems (OS).

6.1 Setting Up Your PL OS

The Digital Electronics Corporation has prepared the following additional program files which are not supported by the standard versions of the Windows® 95, Windows® 98 Second Edition and Windows NT®4.0 operating systems. These files must be installed from the additional “Driver & Utility Disk” and the “USB Touch Panel Control Utility Disk”.

To set up the OS with these files, you will need to prepare one of the FDD units, the PL-FD200 or the PL-FD210 (only for the PL-B910/PL-B900), and a PS/2 compatible keyboard.

Depending on a Touch Panel connection method, the software contained in the PL's accompanying “PL-X900 Series Driver & Utility Disk” and the “USB Touch Panel Control Utility Disk” is designed specifically for use with only the Windows type of OS. If this software is used with other OS types, its performance cannot be guaranteed. **Reference** 1.1.1 Touch Panel Connection

Touch Panel Cable	OS Type	Utility Disk
RS-422	Windows® 95, Windows NT® 4.0	PL-X900 Series Driver and Utility Disk
USB	Windows® 98 Second Edition	PL-B910 Series Driver and Utility Disk
		USB Touch Panel Control Utility Disk



- Be sure to read the Driver and Utility Disk README documents prior to using the PL unit, since they contain the latest PL related information and manual updates as well as the software's details and installation method.
- [README.95] for Windows® 95 and [README.NT] for Windows NT® 4.0 are in [PL-X900 Series Driver & Utility Disk], also [README.98] for Windows® 98 Second Edition is in [USB Touch Panel Control Utility Disk].

Chapter 6 - Bundled Software

The README file contains the following information.

Windows® 95 (README.95)

- I. Preface
- II. Cautions
- III. Software Configuration
- IV. Installation Method
- V. Software Installation

Windows NT® 4.0 (README.NT)

- I. Preface
- II. Cautions
- III. Software Configuration
- IV. Installation Method
- V. Software Installation
- VI. System Automatic Log-On Settings
- VII. Uninterrupted Power Supply

Windows® 98 Second Edition (README.98)

- I. Preface
- II. Cautions
- III. Software Configuration
- IV. Installation Method
- V. Software Installation

6.1.1 Touch Panel Device Driver Settings

To use a touch panel, such as DU and FP, for PL, the following touch panel drivers will be needed.

Model	OS	Touch Panel Device Driver
DU	Windows® 95	Digital PL-ME000
	Windows NT® 4.0	Gunze TT-WINNT
	Windows® 98 Second Edition	Attached to the PL
FP-570	Windows® 95	Digital PL-ME000
	Windows NT® 4.0	Gunze TT-WINNT
	Windows® 98 Second Edition	Touch Panel can not be used.
FP-2500/FP-2600	Windows® 95	Digital PL-TD000
	Windows NT® 4.0	
	Windows® 98 Second Edition	



The PL-ME000 software is designed exclusively by Digital for the Windows® 95 OS. The Gunze corporation's TT-WINNT software's performance is still being evaluated by Digital for the Windows NT® 4.0 system.

■ Touch Panel Device Driver Installation

<DU with Windows® 98 Second Edition >

For the touch panel device driver installation procedure, refer to USB Touch Panel Control Utility Disk's README.98.

<DU or FP-570 with Windows® 98 Second Edition or Windows NT® 4.0>

When installing PL-ME000 and TT-WINNT, the following dialog boxes will be used. Enter the settings given here in these screens.

◆ **Hardware Controls(Serial)**

COM Port

When connecting the Standard display: COM 4

When connecting the FP-570: COM 1 or COM 2

Configuration

Address : 2E8

Irq : 10

Baud rate : 9600

Parity : None

Data Bits : 8

Stop Bits : 1

◆ **Button Modes**

Current Button Mode : Time/Tap

◆ **User Controls**

Miscellaneous Settings

Click time : One level slower than Fast

Double Click speed : Slow

Lift off time : Fast

Stabilization : Low

Touch Offset : Leave unselected

Sound : Select (check mark)

Button simulation : Left

◆ **Advanced Settings**

Miscellaneous

Swap X/Y : Leave unselected

Initialize : Leave unselected

<FP-2500 or FP-2600 >

For PL-TD000 installation procedure, refer to the FP-2500/FP-2600 Series User Manual and PL-TD000's Readme.pdf.

Memo

Chapter

7 Maintenance and Inspection

1. Cleaning the Filter
2. Periodic Maintenance Points

7.1 Cleaning the Filter

Since excessive dirt and dust in the filter of the PL's cooling fan can potentially affect the performance of the unit, regular inspection and cleaning of the filter is strongly recommended.

■ PL-B910 Unit

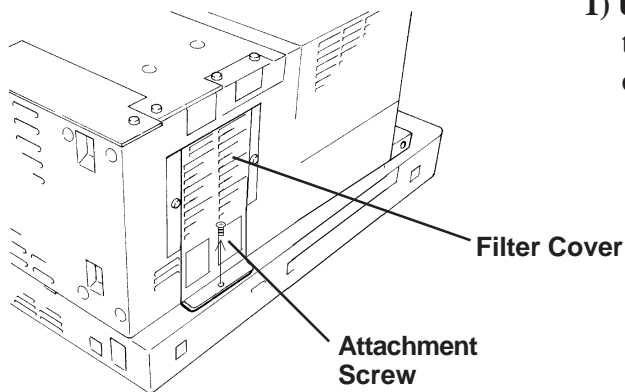

- 1) Unscrew the cooling fan filter cover's attachment screw and remove the filter cover.

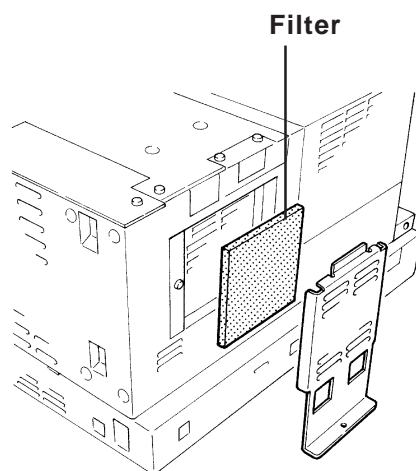

- 2) Remove the filter from the fan cover.

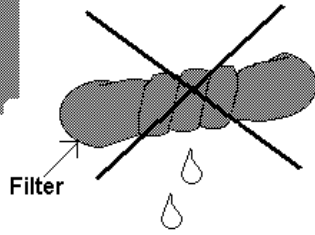
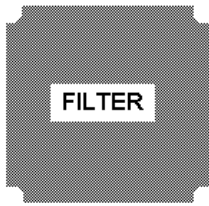

- 3) **Clean the filter completely.**
If stubborn dirt or stains are present, wash the filter with a neutral detergent.
 - **Do not wring the filter to dry it.**
 - **Be sure the filter is completely dry before reattaching the filter to the fan cover.**
 - **Allow it to air dry. Do not leave the filter in direct sunlight.**
- 4) After reattaching the filter to the filter cover, reattach the cover to the cooling unit with the filter cover attachment screw.

■ PL-B901/PL-B911 Unit

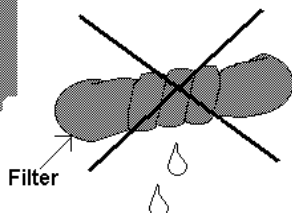
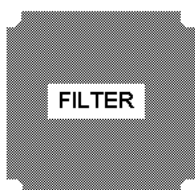
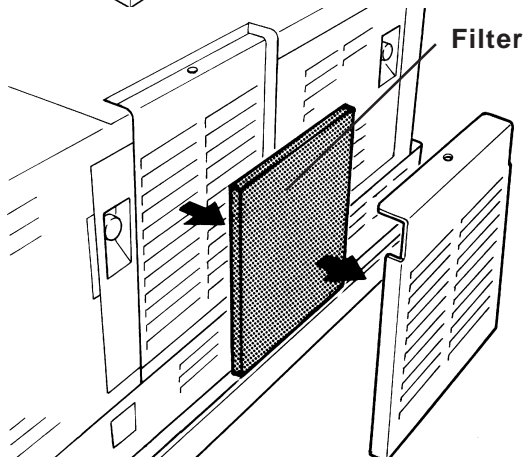
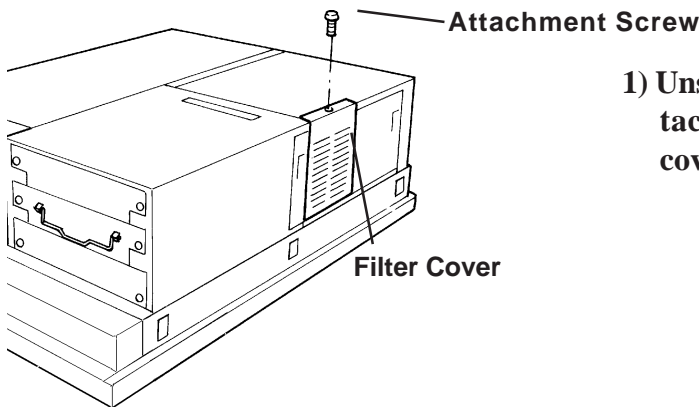

- 1) Unscrew the cooling fan filter cover's attachment screw and remove the filter cover.
- 2) Remove the filter from the fan cover.
- 3) **Clean the filter completely.**
If stubborn dirt or stains are present, wash the filter with a neutral detergent.
 - **Do not wring the filter to dry it.**
 - **Be sure the filter is completely dry before reattaching the filter to the fan cover.**
 - **Allow it to air dry. Do not leave the filter in direct sunlight.**
- 4) After reattaching the filter to the filter cover, reattach the cover to the cooling unit with the cover attachment screw.

7.2 Periodic Maintenance Points

Check the PL periodically to ensure it is in good working condition.

Ambient environment check

- Is the ambient temperature within the specified range?

	When using the HDD,FDD	When NOT using the HDD,FDD
W/ PL Fan	5°C to 50°C	0°C to 50°C
W/OUT PL Fan	5°C to 40°C	0°C to 40°C

- Is the ambient humidity within the specified range (30%RH to 85 %RH) ?
- Is the atmosphere free of corrosive gas ?

Electrical specifications check

- Is the voltage adequate (AC85V to AC265V, 50/60 Hz) ?

Installation check points

- Is the connection cable firmly connected (not loose) ?
- Are any bolts or screws loose ?
- Are there any flaws or tears in the moisture resistant gesket ?

Display check

- Is the display bright enough ?



When the PL's Standard Display's backlight needs to be replaced, please contact your local PL distributor.

Memo



Appendices

A-1 Hardware Configuration

A-2 RAS Feature

A.1 Hardware Configuration

The following data explains the design of the I/O Map, Memory Map and Interrupt Map, as well as additional hardware design items including the RAS feature.

A.1.1 I/O Map

Address	AT System Device	System Device
0000H - 001FH	DMA controller (8237)	
0020H - 003FH	Interrupt controller (8259A)	
0040H - 005FH	System timer (8254)	
0060H - 006FH	Keyboard Controller	
0070H - 007FH	Real-time clock, NMI mask	
0080H - 009FH	DMA page register	
00A0H - 00BFH	Interrupt controller 2 (8259A)	
00C0H - 00DFH	DMA controller 2 (8237)	
00F0H - 00FFH	Numeric data processor	
01F0H - 01FFH	Hard disk (IDE)	
0200H - 0207H	Game I/O	
0290H - 0297H	Reserved	System Monitor
0298H - 029FH	Reserved	RAS
02E8H - 02EFH	Reserved	Touch Panel Serial Port 4 (COM4) (for Standard monitor)
02F8H - 02FFH	Serial port 2 (COM2) : General Use	
03B0H - 03BBH	Video controller (VGA)	
03BCH - 03BFH	Parallel port 1 (LPT1)	
03C0H - 03DFH	Video controller (VGA)	
03E8H - 03EFH	Reserved	Serial port 3 (COM3)
03F0H - 03F7H	Floppy disk controller	
03F8H - 03FFH	Serial port 1 (COM1) :General Use	

A.1.2 Memory Map

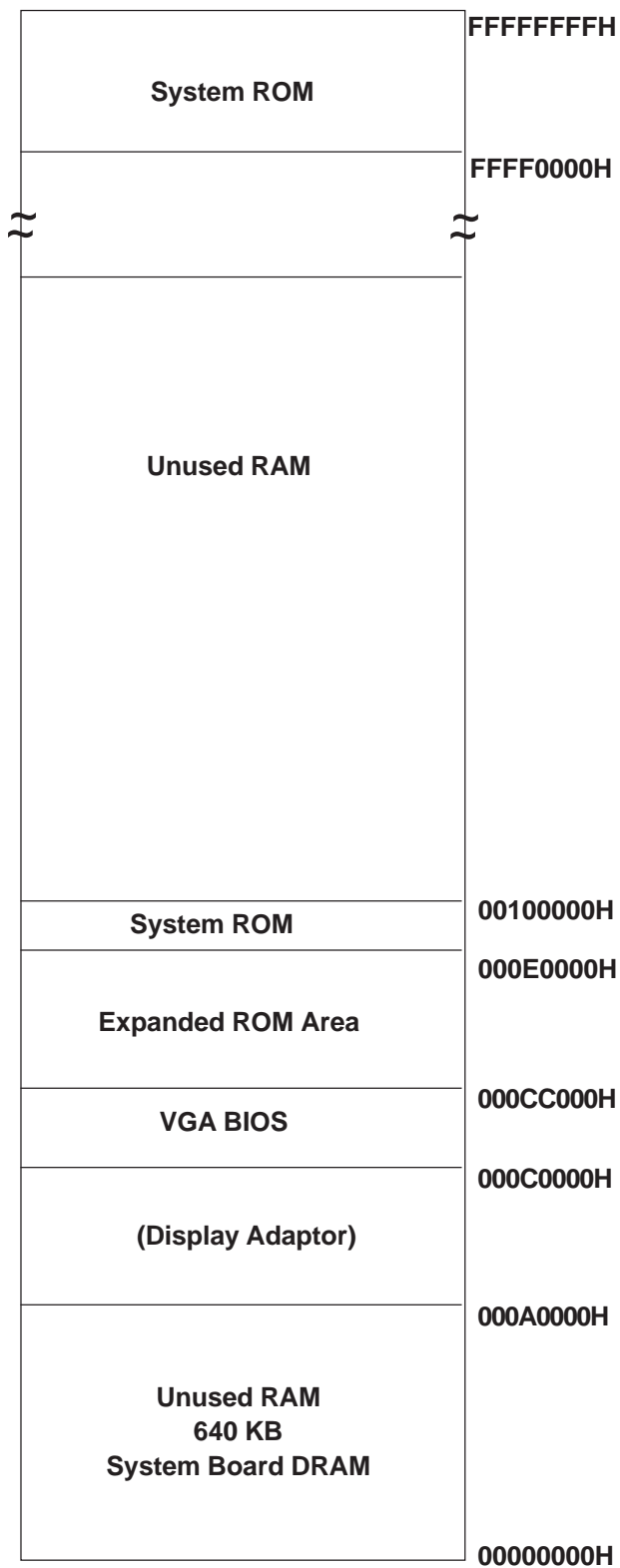

A.1.3 Interrupt Map

■ Hardware Interrupt List

	Description
NMI 0	Parity Error or I/O Channel Check
IRQ 0	Timer (in the Chipset)
IRQ 1	Keyboard
IRQ 2	Cascade from Controller 2
IRQ 3	Serial Port 2 (COM2): General Use Port
IRQ 4	Serial Port 1 (COM2): General Use Port
IRQ 5	Available for users
IRQ 6	Floppy Disk Controller
IRQ 7	Parallel Port 1 (LPT1) : Printer Port
IRQ 8	Real Time Clock
IRQ 9	Serial Port 3 (COM3): General Use Port
IRQ 10	Serial Port 4 (COM4): Touch Panel (for Standard monitor)
IRQ 11	Available for users
IRQ 12	PS/2 Mouse
IRQ 13	Numeric Data Processor
IRQ 14	Hard Disk (IDE)
IRQ 15	RS-422 connection: User Created, USB connection:USB port



IRQ15 is controlled by the System Information "CHIPSET FEATURES SETUP" area. Use the "On Chip USB" settings [Enabled] (USB connection) or [Disabled] (RS-422 connection).

■ DMA Channel List

	Description	
DMA 0		For 8-bit transmission
DMA 1		
DMA 2	Floppy disk controller	
DMA 3		For 16-bit transmission
DMA 4	Cascade to controller 1	
DMA 5		
DMA 6		
DMA 7		

A.2 RAS Feature

A.2.1 PL's RAS Features

RAS, which stands for Reliability, Availability and Serviceability, is a device-level monitoring function that provides a variety of features to improve the reliability of your PL system.

Though the standard set of RAS features used will vary depending on the devices used, the following features are used to provide Alarm Monitoring and External Input Signal support.

Alarm Monitoring	Power Voltage Alarm Cooling Fan Alarm Internal Temperature Alarm Watchdog Timer Time Up Mirror Disk Alarm
External Input Signal	Standard Signal Input (DIN 2 bit) Remote Reset Input

Also, when either the one of the above mentioned alarms occurs, or an external signal input is received, the following types of alarm processing output signals and features are supported.

External Output Signal	Standard Signal Output (DOUT 1 bit) Alarm Output (1 point) Lamp Output (1 point)
Types of Processing (all units)	LED Indicator (3-state display – 1 point) Pop-up Message Output Buzzer Output System Shutdown

Furthermore, using the PL's System Monitor feature (included in the PL's software utility disk), allows the easy setting and control (Enable/Disable) of the aforementioned Alarm Monitor and External Input Signals.

Last, the system monitor feature's use of an Application Link Library (API-DLL) allows it to also be used with other applications.

**1 When a Mirror Disk Alarm occurs and the standard RAS feature settings are used, the alarm output is limited to the Mirror Disk unit's LED indicator. (Alternately flashing orange and green)*

**2 The remote reset feature's input can be either enabled or disabled, the alarm output setting cannot be set to trigger a forced system reset.*

**3 For System Monitor Feature details, refer to the accompanying Driver and Utility disk.*

A.2.2 RAS Feature Details

■ Alarm Monitoring

◆ Power Voltage Alarm

Monitors the condition of the PL's internal and CPU power.

◆ Cooling Fan Alarm

Monitors the condition of the PL's internal power and CPU cooling fans.

◆ Internal Temperature Alarm

Monitors the PL's internal and CPU vicinity temperatures.

The degree of monitoring (3 levels) and the enabling or disabling of the above three items is performed via the System Setup Area's settings.

For detailed information about the monitoring level settings,

Reference 5.2.6 SYSTEM MONITOR UTILITY

This utility can also be used to enable or disable the above mentioned features, as well as designate what type of processing is to be performed.

◆ Watchdog Timer Time Up

This feature alternately writes Time Up Count values from the CPU to the RAS feature's special programmable timer and then periodically clears them, which provides a means of monitoring the CPU's performance. If the clearing of this count value is stopped, the timer will overflow and an alarm will be detected. The System Monitor utility can be used to enable or disable this feature, as well as designate what type of processing is to be performed.

◆ Mirror Disk Alarm

Whenever a disk crash, or other alarm event occurs to the optional Mirror Disk unit, this unit's LED indicator will flash (either orange or green) to indicate there is a problem.

This unit's error detection occurs independently of and cannot be set by the RAS feature.

■ **External Input Signal**

The PL’s RAS interface connector uses the following input signals.

Standard Signal Input (DIN)

This standard digital input is used for alarm detection in external devices. The input signal uses two bits.

The System Monitor utility can be used to enable or disable this feature, as well as designate what type of processing is to be performed once a signal is received.

Remote Reset Input

This is the reset signal sent from an external device to the PL. When this signal is enabled, a forced reset of the PL is performed.

The System Monitor utility can be used to enable or disable this feature

External Input Signal (for both DIN and Remote Reset Input)

- External Power DC12V to DC24V connections are possible
- Input Protection Protection Diode
- Isolation Used (photo-isolation)

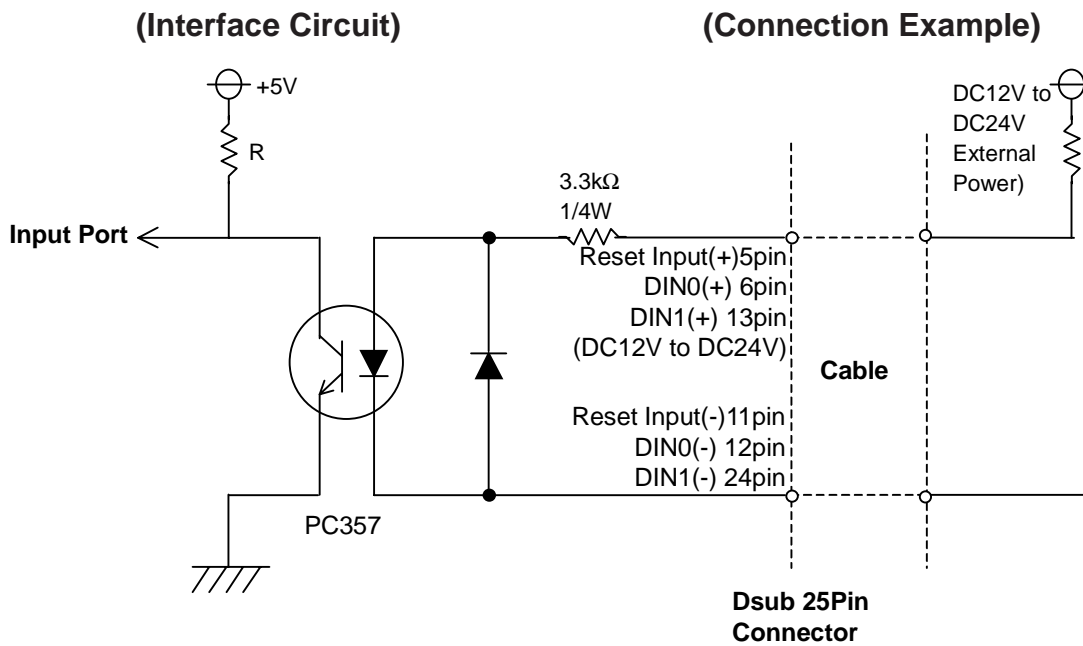

Note: For connection pin location details, **Reference** 2.3.5 RAS Interface

■ External Output Signal

The PL's RAS interface connector uses the following output signals.

General Purpose Signal Output (DOUT)

This general purpose digital output signal provides system condition information to external devices.

The System Monitor's API-DLL are used by applications to control this signal.

Alarm Output (1 point)

Lamp Output (1 point)

The above mentioned general purpose digital output signals provide system condition information to external devices.

The System Monitor utility can be used to enable or disable any of these output signals.

Also, when alarm output is enabled, the orange colored LED indicator will also blink.

External Output Signal (used for DOUT, Alarm Output, Lamp Output)

- Output Specification DC24V 100mA (MAX)
- Isolation Used (photo-isolation)

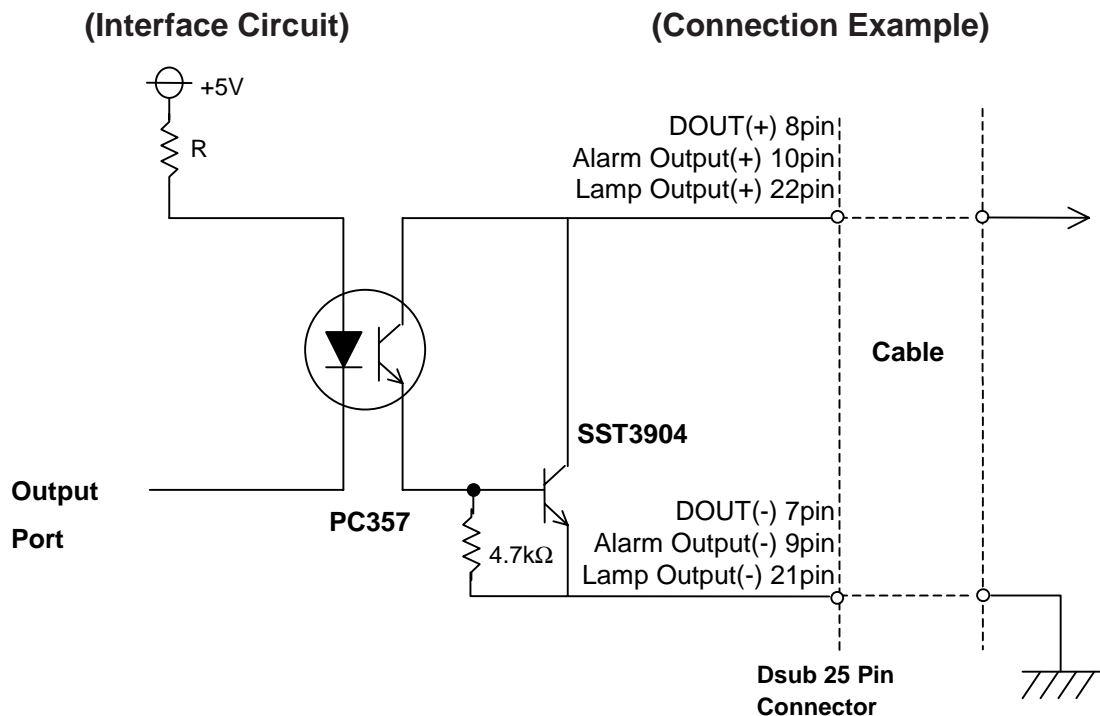

For connection pin location details,
Reference 2.3.5 RAS Interface

■ Types of Processing (all units)

The PL provides system condition information via the following methods.

LED Indicator (3-state display – 1 point)

In addition to indicating if the unit's power is ON or OFF, the 3-state LED indicator (power lamp) provides the following system condition information.

Color	System Condition	Output Created
Green	Normal Operation (Power ON)	None
Orange	RAS has detected a system alarm.	The alarm output set in the system monitor is enabled.
Flashing Orange/ Green	Mirror Disk Alarm has occurred	None

Pop-up Message Output

This feature uses the Windows® system's pop-up message feature to indicate that an alarm has occurred.

Buzzer Output

This feature uses the PL's internal speaker to indicate the system's condition.

System Shutdown

This feature shuts down the PL's OS (Windows® 95/ Windows® 98 Second Edition/ Windows® NT 4.0). The System Monitor utility can be used to enable or disable this feature.

A.2.3 RAS Feature Overview

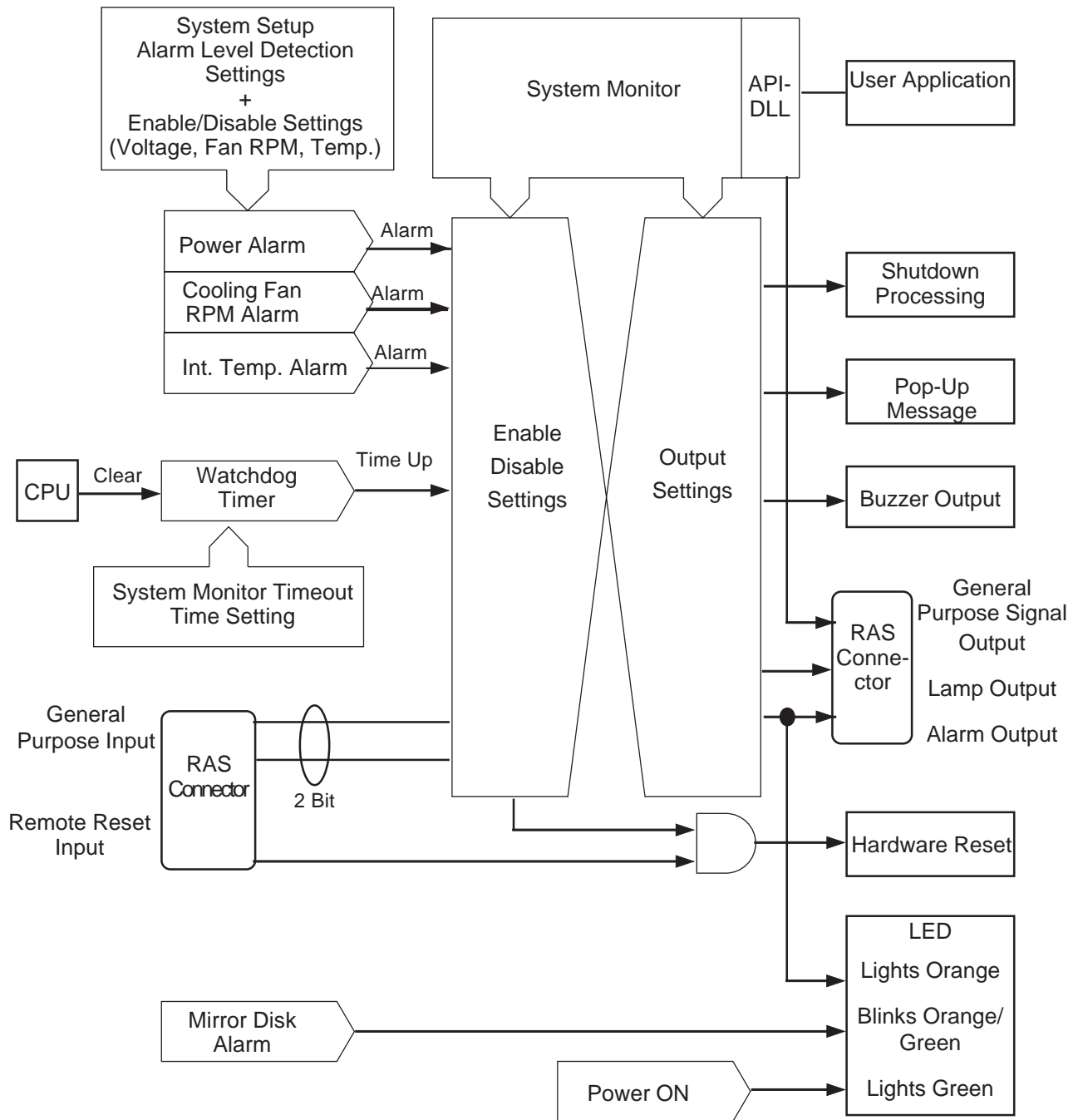

Memo

Index

Characters

16-bit transmission App-3

8-bit transmission App-3

A

AC power terminals 4-6

ACPI I/O Device Node 5-10

Advanced Settings 6-3

aerospace equipment 3

air circulation vents 4

Alarm Monitoring App-5

Alarm Output (1 point) App-7

Ambient environment 7-3

ambient humidity 7-3

Analog RGB connector 3-13

Analog RGB connector cover 2-11, 3-13

Application Link Library App-4

arc-generating devices 4-2

Assign IRQ For USB 5-12

Attachment Bracket Attachment Holes 2-14, 2-15

automatic detection 5-17

B

backlight 7-3

BIOS FEATURES SETUP 5-4, 5-6

Boot Sequence 5-4

Boot Up Floppy Seek 5-5

Boot Up NumLock Status 5-5

Boot Up System Speed 5-5

Button Modes 6-3

Buzzer Output App-8

C

C8000-CBFFF Shadow to DC000-DFFFF Shadow 5-6

Cache Rd+CPU Wt Pipeline 5-7

Cache Timing 5-7

CAUTIONS 4

Cautions When Connecting I/O Signal Lines 4-7

CE Marking Notes 11

CHIPSET FEATURES SETUP 5-6

Cleaning the Filter 7-1

Clock (RTC) Accuracy 2-4

Commercially Available Items 1-8

condensation 4

conduits 4-7

Connecting an Analog RGB Monitor 3-13

Connecting the CD-ROM Unit 3-10, 3-11

Connecting the Power Cord 4-4

Connecting the Standard Display 3-12

connection cable 7-3

Constant voltage transformer 4-6

Cooling Filter Cover 3-15

Copyright 1

corrosive gas 7-3

corrosive gases 4-2

CPU FAN 5-13

CPU Internal Cache 5-4

CPU to PCI Write Buffer 5-11

CPU Warning Temperature 5-13

crime prevention devices 3

crimp terminals 4-5

CRT Interface 2-5

CRT Monitor 3-13

D

damages 4

Date/Time 5-2

Dedicated ground 4-7

Digital Video Interface 10

DIMM module sockets 3-4

direct sunlight 4

Display check 7-3

Display Features 2-3

DMA / master 5-9

DMA Channel List App-3, App-3

DMA-0 assigned to - DMA-7 assigned to 5-11

Documentation Conventions 8

Doze Mode 5-9

DRAM Read Pipeline 5-7

E

ECP Mode Use DMA 5-15

electric hazards 3-1, 4-4

electric shocks 4-4

Electrical 2-1

electrical shock 2

Index

Electrical Specifications 2-1
Electrical specifications check 7-3
end-use product 11
Environmental 2-2
Environmental Specifications 2-2
equipment damage 4-4
errors or omissions 1
Essential Safety Precautions 2
excessive vibration 4-2
expansion boards 10
Expansion Slots 2-4, 2-10
External Cache 5-4
external data backup 4

F

failsafe system design 3
Fan Unit 3-15
FDD Slot 2-10, 2-11
Features and Performance 2-3
ferrite core 4-6
FG terminal 4-7
Filter 3-16
Filter Cover 2-11, 7-1
fire 4-4
fire or electrical shock 2
flammable gases 3
Floppy Disks 9
Front Face FDD Slot 2-10
Front Face FDD Unit Attachment Slot 2-9
Full Sized Cover Attachment Dimensions 1-4, 2-16
Functional Specifications 2-3

G

Gate A20 Option 5-5
General 2-3
General Purpose Signal Output (DOUT) App-7
General Specifications 2-1
Graphic Panel Dimensions 2-12
Grounding Cautions 4-7
grounding point 4-7

H

Half Cover 2-11
Hardware Configuration App-1
Hardware Controls(Serial) 6-3
Hardware Interrupt List App-3
Hardware Interruption List App-3
Hardware Reset Switch 2-10
hardware setup 1-2
HDD & FDD 5-9
HDD Power Down 5-9
HDD/FDD Expansion Slot 2-10
HDD/FFD Expansion Slot 3-8
high temperatures 4
high voltages 2
High-Performance Architecture 10
humidity 4

I

I/O device 4-6
I/O Map App-1
I/O power source 4-6
I/O signal lines 4-6
IDE HDD Block Mode 5-14
IDE HDD AUTO DETECTION 5-17
IDE HDD AUTO DETECTION SETUP 5-17
IDE I/F Cover 2-9
IDE Prefetch Mode 5-14
IDE Primary Master PIO 5-14
IDE Primary Master UDMA 5-15
IDE Primary Slave PIO 5-15
IDE Primary Slave UDMA 5-15
IN2(3.3V) 5-13
IN3(5V) 5-13
IN4(12V) 5-13
IN5(-12V) 5-13
IN6(-5V) 5-13
INO(Vcore) 5-13
Input Port (Dual use of DIN,Remote Set Input Port) 2-7
Installation 3-1, 4-1, 4-3
Installation and Wiring 2, 4-1
Installation Brackets 9
Installation Cautions 4-1, 4-3
Installation check points 7-3
Installation Fasteners 2-14
Installation Location 4-2

Installation Positioning Cautions 4-1
 Installation Procedures 4-3
 Installing an Expansion Board 3-9
 Installing the DIM Module 3-4
 Installing the FDD Unit 3-5, 3-6
 Installing the PL 4-3
 insulating transformer 4-6
 INTEGRATED PERIPHERALS 5-14
 Interface Circuit App-6
 interface connector 2
 Interface Specifications 2-5
 internal HDD 4
 Interrupt Map App-3
 Introduction 1
 IRQ-3 assigned to - IRQ-15 assigned to 5-11
 IRQ3-IRQ15 5-9

K

Keyboard Connector 2-10
 Keyboard Interface 2-5

L

Lamp Output (1 point) App-7
 LED Indicator (3-state display -1 point) App-8
 lightning 4-6
 lightning surge absorber 4-6
 low-noise power supply 4-6
 LPT & COM 5-9

M

magnetic switches 4-2
 main circuit 4-6
 Main power source 4-6
 Maintenance Options 1-4, 1-8
 medical devices 3
 Memory Hole At 15Mb Addr. 5-7
 Memory Map App-2
 Memory Mapping App-2
 Memory Parity / ECC Check 5-5
 metal particles 2
 Middle Expansion Slot 3-8
 MODEM Use IRQ 5-9
 moisture resistant packing 7-3
 Mouse Connector 2-10
 Mouse Interface 2-5

N

noise immunity 4-6
 non-fuse breakers 4-2
 nuclear power control devices 3

O

On Chip USB 5-7
 Onboard FDC Controller 5-15
 Onboard Parallel Port 5-15
 Onboard Serial Port 3 5-16
 Onboard Serial Port 4 5-16
 Onboard Serial Port1 5-15
 Onboard Serial Port2 5-15
 OnChip IDE First Channel 5-14
 Optional Items 1-7
 OS Select For DRAM >64MB 5-6
 overheating 4

P

Package Contents 9
 panel's viewing angle 4-1
 PCI #2 Access #1 Retry 5-11
 PCI Delay Transaction 5-11
 PCI Dynamic Bursting 5-11
 PCI IRQ Activated by 5-12
 PCI Master 0 WS Write 5-11
 PCI Master Read Prefetch 5-11
 PCI slots 10
 PCI/VGA Palette Snoop 5-5
 Periodic Maintenance Points 7-3
 peripheral equipment 1-6
 PL External Dimensions 2-12
 PL Installation 3-1
 PL OS Setup 6-1
 PL Part Names and Features 2-9
 PL power source 4-6
 PL Series Model Numbers 8
 PL System Configuration 1-6
 PL-B900/B901 Unit External Dimensions 2-12
 Plastic Cover 4-4
 PL's backlight 7-3
 PL's frame 4-4
 PM Control by APM 5-8
 PNP OS Installed 5-10

Index

PNP/PCI CONFIGURATION SETUP 5-10

Pop-up Message Output App-8

Positioning Strip 3-9

possible explosion 3

Power Cable Connector 3-16

Power Cord 9

power cord 4-4

Power FAN 5-13

Power Input Terminals 4-4

Power LED 2-10

Power LED Output Connector 2-10

POWER MANAGEMENT SETUP 5-8

Power Supply Cautions 4-6

power supply devices 4-6

power supply voltage 4-4

Power Switch 2-11

Power Terminals 2-9

Power Voltage Alarm App-5

pre-set 5-1

Primary INTR 5-9

Printer Interface (LPT1) 2-6

Printer Connector (LPT1) 2-9

Prior to Operating the PL 1-1

Product names 1

Q

Quick Power On Self Test 5-4

R

RAS Interface 2-7

RAS Connector 2-9

RAS Feature App-4

RAS Feature Overview App-9

Rear Maintenance Cover 2-9, 2-11

Remote Reset Input App-6

Removing the Cooling Fan Unit 3-15

Removing the Rear Maintenance Cover 3-2

Removing/ Installing the HDD Unit 3-8

Reset Configuration Data 5-10

Resources Controlled By 5-10

RS-232C Interface (COMM1/COM2/COM3) 2-6

RS-232C Connector (COM1) 2-9

RS-232C Connector (COM2) 2-9

RS-232C Connector (COM3) 2-9

S

Safety Precautions 2

screw size 4-4

SDRAM Cycle Length 5-7

Security Option 5-5

Serial Interface 2-5, 2-6, 2-7

Serial Port 4 Use IRQ 5-16

Setup Procedures 5-1

Shared Ground 4-7

specified voltage 4-6

STANDARD CMOS SETUP 5-2

Standard Signal Input (DIN) App-6

Structural 2-1

Structural Specifications 2-1

Suspend Mode 5-9

Sustained 3T Write 5-7

System BIOS Cacheable 5-7

System Monitor feature App-4

SYSTEM MONITOR UTILITY 5-12

System Setup 5-1, 6-1

System Shutdown App-8

System Warning Temp 5-13

T

Table of Contents 5

Temperature Related Cautions 4-1

terminal strip 4-5

Touch Panel Signals 10

trademarks 1

Transparent Cover 4-4

transparent plastic cover 4-4

transportation vehicles 3

Twisted-pair cable 4-6

Typematic Delay (Msec) 5-5

Typematic Rate (Chars/Sec) 5-5

Typematic Rate Setting 5-5

U

UL/c-UL(CSA) Application Notes 11

used batteries 11

User Controls 6-3

V

Vertical Installation 4-1

VGA 5-9

VGA Graphics Mode 5-3
VGA Text Mode 5-3
Vibration and Shocks 4-2
Video BIOS Cacheable 5-7
Video BIOS Shadow 5-6
Video Off Method 5-8
Video Off Option 5-8
Virus Warning 5-4

W

WARNING 4-4
WARNINGS 3
Windows NT 6-1

Memo