

Pro-face

by **Schneider** Electric

PS5000 Series

User Manual

(Modular Type)

The information provided in this documentation contains general descriptions and/or technical characteristics of the performance of the products contained herein. This documentation is not intended as a substitute for and is not to be used for determining suitability or reliability of these products for specific user applications. It is the duty of any such user or integrator to perform the appropriate and complete risk analysis, evaluation and testing of the products with respect to the relevant specific application or use thereof. Neither Pro-face nor any of its affiliates or subsidiaries shall be responsible or liable for misuse of the information that is contained herein. If you have any suggestions for improvements or amendments or have found errors in this publication, please notify us.

No part of this document may be reproduced in any form or by any means, electronic or mechanical, including photocopying, without express written permission of Pro-face.

All pertinent state, regional, and local safety regulations must be observed when installing and using this product. For reasons of safety and to help ensure compliance with documented system data, only the manufacturer should perform repairs to components.

When devices are used for applications with technical safety requirements, the relevant instructions must be followed.

Failure to use Pro-face software or approved software with our hardware products may result in injury, harm, or improper operating results.

Failure to observe this information can result in injury or equipment damage.

Copyright © 2016.10 Digital Electronics Corporation. All Rights Reserved.

Table of Contents



	Safety Information	5
	About the Book	7
Chapter 1	Important Information	13
	FCC Radio Frequency Interference Statement for USA	14
	Certifications and Standards	15
	Hazardous Location Installations - For USA and Canada	17
Chapter 2	Physical Overview	21
	Package Contents	22
	Box Celeron and Box Core i7 Description	25
	Display Module Description	30
	Display Adapter Description and Configuration	33
Chapter 3	Characteristics	37
	Box Characteristics	38
	Display Characteristics	40
	Display Adapter and Receiver / Transmitter Characteristics	41
	Power Supply Characteristics	43
	Environmental Characteristics	44
Chapter 4	Dimensions	45
	Box Dimensions	46
	Display Module Dimensions	48
	Display Adapter Dimensions	50
Chapter 5	Installation	51
	Introduction	52
	Box Installation	53
	Display Module and Box Installation	55
	Display Module and Display Adapter Installation	63
Chapter 6	Getting Started	69
	First Power up	69
Chapter 7	Connections	71
	Grounding	72
	Connecting the DC Power Cord	76
	AC Power Supply Module Description and Installation	79
	UPS Module - Description and Installation	90
	Box Interface Connections	98
Chapter 8	Configuration of the BIOS	103
	BIOS Main Menu	104
	Advanced Menu	105
	Chipset Menu	107
	Boot Menu	109
	Security Menu	110
	Save & Exit Menu	111

Chapter 9	Hardware Modifications	113
9.1	Before Modifications	114
	Before Making Modifications	114
9.2	Box and Storage Modifications	116
	HDD/SSD Drive Installation	117
	Memory Card Installation	120
	mSATA Card Installation	122
	mini PCIe and PCI/PCIe Card Installation	125
9.3	Box and Fan Kit Installation	130
	Fan Kit Installation	130
9.4	Box and Optional Interfaces	132
	Optional Interface Installation	133
	16DI/8DO Interface Module Description	139
	RS-232, RS-422/485 Interface Module Description	143
	Ethernet IEEE Interface Module Description	148
	Ethernet PoE Interface Module Description	150
	CANopen Interface Module Description	152
	Profibus DP Interface Module Description	155
	Audio Interface Description	157
	USB Interface Module Description	158
	Cellular Module	160
	Transmitter for PS5000	163
Chapter 10	System Monitor	165
	System Monitor Interface	166
	Device Management - Monitoring Rules	171
	Account Setting - System Setting	189
Chapter 11	Software API	197
	Intelligent Management for Embedded Platform	197
Chapter 12	Maintenance	199
	Reinstallation Procedure	200
	Regular Cleaning and Maintenance	201
Appendices	203
Appendix A	Accessories	205
	Accessories for the Box	205
Appendix B	After-sales Service	207
	After-sales Service	207

Safety Information



Important Information

NOTICE

Read these instructions carefully, and look at the equipment to become familiar with the device before trying to install, operate, service, or maintain it. The following special messages may appear throughout this documentation or on the equipment to warn of potential hazards or to call attention to information that clarifies or simplifies a procedure.



The addition of this symbol to a “Danger” or “Warning” safety label indicates that an electrical hazard exists which will result in personal injury if the instructions are not followed.



This is the safety alert symbol. It is used to alert you to potential personal injury hazards. Obey all safety messages that follow this symbol to avoid possible injury or death.

DANGER

DANGER indicates a hazardous situation which, if not avoided, **will result in** death or serious injury.

WARNING

WARNING indicates a hazardous situation which, if not avoided, **could result in** death or serious injury.

CAUTION

CAUTION indicates a hazardous situation which, if not avoided, **could result in** minor or moderate injury.

NOTICE

NOTICE is used to address practices not related to physical injury.

PLEASE NOTE

Electrical equipment should be installed, operated, serviced, and maintained only by qualified personnel. No responsibility is assumed by Pro-face for any consequences arising out of the use of this material.

DANGER

HAZARD OF ELECTRIC SHOCK

- Do not open product.
- Product to be serviced by qualified people only.

Failure to follow these instructions will result in death or serious injury.

A qualified person is one who has skills and knowledge related to the construction and operation of electrical equipment and its installation, and has received safety training to recognize and avoid the hazards involved.

About the Book



At a Glance

Document Scope

This manual describes the configuration and usage of the PS5000 Series Box Type (from now on referred to as the Box) and Modular Panel Type (from now on referred to as the Display Module).

The Box and the Display Module are designed to operate in an industrial environment.

The configuration number format is as follows:

Character number	Prefix (1-4)	5	6	7	8	9	10	11	12	13	14	15	16	17	18
Part number	PFXP														
Base unit	Modular PC Celeron	U													
	Modular PC Core i7	P													
	Display Adapter	A													
Product generation	Second generation		2												
Modular panel type	None (Box)			B											
	Modular panel 15"			7											
	Modular panel W15"			J											
	Modular panel W19"			L											
	Modular panel W22"			N											

Character number	Prefix (1-4)	5	6	7	8	9	10	11	12	13	14	15	16	17	18
Box type	None				N										
	Box Celeron 4 GB-RAM				C										
	Box Celeron 8 GB-RAM				D										
	Box Celeron 4 GB-RAM 1 x PCI + 1 x PCIe				E										
	Box Core i7 8 GB-RAM				J										
	Box Core i7 8 GB-RAM 1 x PCI + 1 x PCIe				K										
	Box Celeron 8 GB-RAM 1 x PCI + 1 x PCIe				P										
	Box Celeron 4 GB-RAM, 2 x PCI				Q										
	Box Celeron 8 GB-RAM, 2 x PCI				R										
	Box Celeron 4 GB-RAM, 2 x PCIe				S										
	Box Celeron 8 GB-RAM, 2 x PCIe				T										
	Box Core i7 16 GB-RAM				U										
	Box Core i7 16 GB-RAM 1 x PCI + 1 x PCIe				V										
	Box Core i7 8 GB-RAM, 2 x PCI				W										
	Box Core i7 16 GB-RAM, 2 x PCI				X										
	Box Core i7 8 GB-RAM, 2 x PCIe				Y										
	Box Core i7 16 GB-RAM, 2 x PCIe				Z										
	Box Core i7 16 GB-RAM, conformal coating				A										
Box Core i7 16 GB-RAM, conformal coating 1 x PCI + 1 x PCIe				L											
CPU type	None				N										
	Celeron-2980U				C										
	Core i7-4650U				7										
	Celeron-2980U with fan for expansion card above 3 W				F										
	Core i7-4650U with fan for expansion card above 3W				W										
Power supply	DC					D									
	AC					A									
RAM sizes	None							N							
	4 GB							4							
	8 GB							8							
	16 GB							A							
Operating system	None								0						
	Windows Embedded Standard 7 (WES7P) SP1 64 bits MUI								4						
	Windows 7 Ultimate SP1 64 bits MUI								6						
	Windows Embedded 8.1 Industry 64 bits MUI								8						

Character number	Prefix (1-4)	5	6	7	8	9	10	11	12	13	14	15	16	17	18
Storage device	None									N					
	CFast 16 GB									A					
	CFast 32 GB									X					
	HDD 500 GB									J					
	HDD 1 TB									K					
	SSD 80 GB									L					
	SSD 160 GB									M					
	SSD 240 GB									P					
Options	None										0				
	Interface 2 x RS 422/485 isolated										2				
	Interface 4 x RS 422/485										3				
	Interface 2 x USB 3.0										4				
	Interface 2 x RS 232 isolated										5				
	Interface 4 x RS 232										6				
	Interface 2 x Ethernet Gigabit PoE LAN										7				
	Interface 16 x DI / 8 x DO										8				
	Interface audio										C				
	Cellular module										D				
	Interface 2 x CANopen										G				
	Interface 1 x Profibus DP with NVRAM										J				
	Interface 1 x Ethernet Gigabit IEEE1588 LAN										K				
Second storage	None										N				
	CFast 16 GB										A				
	CFast 32 GB										X				
	HDD 500 GB										J				
	HDD 1 TB										K				
	SSD 80 GB										L				
	SSD 160 GB										M				
	SSD 240 GB										P				
Software bundle	None										N				
	BLUE license key code										B				
	WinGP license key code										G				
	Pro-face remote HMI server license key code										R				
	BLUE and Pro-face remote HMI server license key code										H				
	WinGP and Pro-face remote HMI server license key code										J				
	BLUE Open Studio runtime 1.5 K license key code										C				
	BLUE Open Studio runtime 4 K license key code										D				
	BLUE Open Studio runtime 64 K license key code										E				
Customization	None										0				
Spare	None														0

NOTE: All instructions applicable to the enclosed product and all safety precautions must be observed.

Validity Note

This document is valid for the PS5000 Series Box type.

The technical characteristics of the device(s) described in this manual also appear online at <http://www.pro-face.com/>.

The characteristics presented in this manual should be the same as those that appear online. In line with our policy of constant improvement we may revise content over time to improve clarity and accuracy. In the event that you see a difference between the manual and online information, use the online information as your reference.

Registered trademarks

Microsoft and Windows are registered trademarks of Microsoft corporation in the United States and/or other countries.

Intel, Haswell, Core, and Celeron are registered trademarks of Intel corporation.

Product names used in this manual may be the registered trademarks owned by the respective proprietors.

Hazardous Location

The Boxes PFXPP2B, PFXPU2B, PFXPP27, PFXPP2J, PFXPU27, PFXPU2J, and the Display Adapter PFXZPPDADDP2 are classified hazardous locations Class I Division 2 (see chapter "Certifications and Standards"). Observe the following:

DANGER

POTENTIAL FOR EXPLOSION

- Always confirm the ANSI/ISA 12.12.01 and CSA C22.2 N°213 hazardous location rating of your device before installing or using it in a hazardous location.
- To power on or power off a Box installed in a Class I, Division 2 hazardous location, you must either:
 - Use a switch located outside the hazardous environment, or
 - Use a switch certified for Class I, Division 1 operation inside the hazardous area.
- Do not connect or disconnect equipment unless power has been switched off or the area is known to be non-hazardous. This applies to all connections including power, ground, serial, parallel, network, and rear USB connections.
- Never use unshielded / ungrounded cables in hazardous locations.
- When enclosed, keep enclosure doors and openings closed at all times to avoid the accumulation of foreign matter inside the workstation.
- Do not use front USB and keep the cover in place.
- Do not expose to direct sunlight or UV light source.

Failure to follow these instructions will result in death or serious injury.

NOTE: When using a Display Module PFXPPD5700TA or a Display Module PFXPPD5700WP with the Box Celeron and Box Core i7 (classified hazardous locations) can be classified hazardous locations.

NOTE: When using DC power supply, Display Adapter (PFXZPPDADDP2) with the Display Module can be classified hazardous locations. When using AC power supply, the Display Adapter with the Display Module and the AC power supply adapter for 100 W (PFXZPBPUAC2) can be classified hazardous location.

The Box PFXPP2L, PFXPP2N, PFXPU2L, PFXPU2N and the Display Module PFXPPD5800WP, PFXPPD5900WP are not classified hazardous locations.

DANGER

POTENTIAL FOR EXPLOSION IN HAZARDOUS LOCATION

Do not use this product in hazardous locations.

Failure to follow these instructions will result in death or serious injury.

Product Related Information

WARNING

LOSS OF CONTROL

- The designer of any control scheme must consider the potential failure modes of control paths and, for certain critical control functions, provide a means to achieve a safe state during and after a path failure. Examples of critical control functions are emergency stop and overtravel stop.
- Separate or redundant control paths must be provided for critical control functions.
- System control paths may include communication links. Consideration must be given to the implications of unanticipated transmission delays or failures of the link.⁽¹⁾
- Each implementation of a Box must be individually and thoroughly tested for proper operation before being placed into service.

Failure to follow these instructions can result in death, serious injury, or equipment damage.

⁽¹⁾ For additional information, refer to *NEMA ICS 1.1 (latest edition), "Safety Guidelines for the Application, Installation, and Maintenance of Solid State Control"* and to *NEMA ICS 7.1 (latest edition), "Safety Standards for Construction and Guide for Selection, Installation and Operation of Adjustable-Speed Drive Systems"* or other applicable standards in your location.

The Display Module 15" single touch has a touch screen with analog-resistive touch technology that may operate abnormally when two or more points are simultaneously used.

WARNING

UNINTENDED EQUIPMENT OPERATION

Do not touch two or more points simultaneously on display.

Failure to follow these instructions can result in death, serious injury, or equipment damage.

The Display Module W15", W19" and W22" multi-touch have a touch screen with projected capacitive touch technology that may operate abnormally when the surface is wet.

 WARNING

LOSS OF CONTROL

- Do not touch the touch screen area during Operating System startup.
- Do not operate when the touch screen surface is wet.
- If the touch screen surface is wet, remove any excess water with a soft cloth before operation.
- Make sure to use only the authorized grounding configurations shown in the grounding procedure.

Failure to follow these instructions can result in death, serious injury, or equipment damage.

NOTE:

- The touch control is disabled in case of abnormal touch (like water) for a few seconds to avoid accidental touch. The normal touch function will be recovered a few seconds after removing the abnormal touch condition.
- Do not touch the touch screen area during Operating System startup since "touch panel firmware" initializes automatically when Windows starts up.

NOTE:

The following characteristics are specific to the LCD and are considered normal behavior:

- LCD screen may show unevenness in the brightness of certain images or may appear different when seen from outside the specified viewing angle. Extended shadows, or cross-talk, may also appear on the sides of screen images.
- LCD screen pixels may contain black and white-colored spots and color display may seem to have changed over time.
- When the same image is displayed on the screen for a long period, an after-image may appear when the image is changed. If this happens, turn off the unit, wait 10 seconds, and then restart it.
- The panel brightness may decrease when used for a long time in an environment continuously filled with inert gas. To prevent deterioration of panel brightness, regularly ventilate the panel.

For more information, please contact your local distributor at <http://www.pro-face.com/trans/en/manual/1015.html>.

NOTE: Do not display the same image for a long time. Change the screen image periodically.

NOTE: The Box is a highly configurable device and is not based on a real-time operating system. Changes to the software and settings of the following must be considered new implementations as discussed in the previous warning messages. Examples of such changes include:

- System BIOS
- System Monitor
- Operating system
- Installed hardware
- Installed software

 WARNING

UNINTENDED EQUIPMENT OPERATION

Use only Pro-face software with the devices described in this manual.

Failure to follow these instructions can result in death, serious injury, or equipment damage.

Chapter 1

Important Information

General

This chapter describes specific aspects related to the operation of the Box.

What Is in This Chapter?

This chapter contains the following topics:

Topic	Page
FCC Radio Frequency Interference Statement for USA.	14
Certifications and Standards	15
Hazardous Location Installations - For USA and Canada	17

FCC Radio Frequency Interference Statement for USA.

FCC Radio Interference Information

This equipment has been tested and found to comply with the federal communications commission (FCC) limits for a Class A digital device, according to Part 15 of the FCC rules. These limits are designed to provide reasonable protection against harmful interference in a commercial, industrial, or business environment. This equipment generates, uses, and can radiate radio frequency energy and, if not installed and used in accordance with the instructions, may cause or be subject to interference with radio communications. To minimize the possibility of electromagnetic interference in your application, observe the following two rules:

- Install and operate the Box in such a manner that it does not radiate sufficient electromagnetic energy to cause interference in nearby devices.
- Install and test the Box to ensure that the electromagnetic energy generated by nearby devices does not interfere with the Box's operation.

Changes or modifications not expressly approved by the party responsible for compliance could void the user's authority to operate this product.

WARNING

ELECTROMAGNETIC / INTERFERENCE

Electromagnetic radiation may disrupt the Box's operations, leading to unintended equipment operation. If electromagnetic interference is detected:

- Increase the distance between the Box and the interfering equipment.
- Reorient the Box and the interfering equipment.
- Reroute power and communication lines to the Box and the interfering equipment.
- Connect the Box and the interfering equipment to different power supplies.
- Always use shielded cables when connecting the Box to a peripheral device or another computer.

Failure to follow these instructions can result in death, serious injury, or equipment damage.

Certifications and Standards

Introduction

Pro-face submitted this product for independent testing and qualification by third-party agencies. These agencies have certified this product as meeting the following standards.

NOTE: Always refer to the markings on the product to confirm the certifications or the following: <http://www.pro-face.com/trans/en/manual/1002.html>.

Certifications for Display Modules PFXPPD5700TA, PFXPPD5700WP, PFXPPD5800WP, and PFXPPD5900WP

- Underwriters Laboratories Inc., UL 60950, and CSA 60950 (Information Technology Equipment).
- RCM, and EAC. Refer to product markings.

Certifications for Box PFXPP2J, PFXPP27, PFXPU27, and PFXPU2J

- As Industrial Control Equipment (UL 61010-2-201 and CSA C22.2 N° 142) and for Hazardous Locations (ANSI/ISA 12.12.01 and CSA C22.2 N° 213, Electrical Equipment for Use in Class I, Division 2 Hazardous Classified Locations). Refer to product markings.
- CCC, RCM, and EAC. Refer to product markings.
- For CE Atex and IEC Ex as 3GD equipment category.

Certifications for Box PFXPP27 and PFXPP2J

- By Merchant Navy agencies.
- CCC, RCM, and EAC. Refer to product markings.

Certifications for Box PFXPP2B and PFXPU2B

- As Industrial Control Equipment (UL 61010-2-201 and CSA C22.2 N° 142) and for Hazardous Locations (ANSI/ISA 12.12.01 and CSA C22.2 N° 213, Electrical Equipment for Use in Class I, Division 2 Hazardous Classified Locations). Refer to product markings.
- For CE Atex and IEC Ex as 3GD equipment category (for DC models).
- For CE Atex and IEC Ex as 3D equipment category (for AC models).

Certifications for Display Modules PFXPPD5700TA, PFXPPD5700WP with a Box PFXPP2B or PFXPU2B

- As Industrial Control Equipment (UL 61010-2-201 and CSA C22.2 N° 142) and for Hazardous Locations (ANSI/ISA 12.12.01 and CSA C22.2 N° 213, Electrical Equipment for Use in Class I, Division 2 Hazardous Classified Locations). Refer to product markings.

Compliance Standards

Pro-face tested this product for compliance with the following compulsory standards:

- United States:
 - Federal Communications Commission, FCC Part 15, Class A
- Europe: CE
 - 2014/35/EU Low Voltage Directive, based on IEC 60950 or IEC 61010-2-201
 - 2014/30/EU EMC Directive, class A, based on IEC 61006-2 and IEC 61006-4
- Australia: RCM
 - Standard AS/NZS CISPR11

Qualification Standards

Pro-face voluntarily tested this product to additional standards. The additional tests performed, and the standards under which the tests were conducted, are identified in the environmental characteristics.

Hazardous Substances

This product is compliant with:

- WEEE, Directive 2012/19/EU
- RoHS, Directive 2011/65/EU
- RoHS China, Standard SJ/T 11364
- REACH regulation EC 1907/2006

End of Life (WEEE)

The product contains electronic boards. It must be disposed of in specific treatment channels. The product contains cells and/or storage batteries which must be collected and processed separately, when they have run out and at the end of product life.

Refer to the section Maintenance to extract cells and batteries from the product. These batteries do not contain a weight percentage of heavy metals over the threshold notified by European Directive 2012/19/EU.

European (CE) Compliance

The products described in this manual comply with the European Directives concerning Electromagnetic Compatibility and Low Voltage (CE marking) when used as specified in the relevant documentation, in applications for which they are intended, and in connection with approved third-party products.

KC Marking

해당 무선설비는 운용 중 전파혼신 가능성이 있음

사용자안내문

기종별	사용자안내문
A급 기기 (업무용 방송통신기자재)	이 기기는 업무용(A급) 전자파적합기기로서 판매자 또는 사용자는 이 점을 주의하시기 바라며, 가정외의 지역에서 사용하는 것을 목적으로 합니다.

해당 무선설비는 전파혼신 가능성이 있으므로 인명안전과 관련된 서비스는 할 수 없습니다

Hazardous Location Installations - For USA and Canada

General

The Boxes PFXPP2B, PFXPU2B, PFXPP27, PFXPP2J, PFXPU27, PFXPU2J, and the Display Adapter PFXZPPDADDP2 are classified hazardous locations Class I Division 2.

Division 2 locations are those locations where ignitable concentrations of flammable substances are normally confined, prevented by ventilation, or present in an adjacent Class I, Division 1 location, but where an abnormal situation might result in intermittent exposure to such ignitable concentrations.

NOTE: When using a Display Module PFXPPD5700TA or a Display Module PFXPPD5700WP with the Box Celeron and Box Core i7 (classified hazardous locations) can be classified hazardous locations.

NOTE: When using DC power supply, Display Adapter (PFXZPPDADDP2) with the Display Module can be classified hazardous locations. When using AC power supply, the Display Adapter with the Display Module and the AC power supply adapter for 100 W (PFXZBPBUAC2) can be classified hazardous location.

While the Box PFXPP2L, PFXPP2N, PFXPU2L, PFXPU2N and the Display Module PFXPPD5800WP, PFXPPD5900WP are a non-incendive device under ANSI/ISA 12.12.01 and CSA C22.2 N°213, it is not designed for, and should never be used within a Division 1 (normally hazardous) location.

This equipment is suitable for use in Class I, Division 2, Groups A, B, C, and D hazardous locations or in non-hazardous locations. Before installing or using your Box PFXPP2B, PFXPU2B, PFXPP27, PFXPP2J, PFXPU27, PFXPU2J and the Display Module PFXPPD5700TA, PFXPPD5700WP, confirm that the ANSI/ISA 12.12.01 or CSA C22.2 N°213 certification appears on the product labeling

DANGER

POTENTIAL FOR EXPLOSION

- Do not use your Box in hazardous environments or locations other than Class I, Division 2, Groups A, B, C, and D.
- Always confirm that your Box is suitable for use in hazardous locations by checking that the ANSI/ISA 12.12.01 or CSA C22.2 N°213 certification appears on the product labeling.
- Do not install any Pro-face or OEM components, equipment, or accessories unless these have also been qualified as suitable for use in Class I, Division 2, Groups A, B, C, and D locations.
- In addition, confirm that any PCI controller cards have an adequate temperature code (T-code), and are suitable for a surrounding air temperature range of 0 to 50 °C (32 to 122 °F).
- Do not attempt to install, operate, modify, maintain, service, or otherwise alter the Box except as permitted in this manual. Non-permitted actions may impair the unit's suitability for Class I, Division 2 operation.

Failure to follow these instructions will result in death or serious injury.

DANGER

POTENTIAL FOR EXPLOSION

- Always confirm the ANSI/ISA 12.12.01 and CSA C22.2 N°213 hazardous location rating of your device before installing or using it in a hazardous location.
- To power on or power off a Box installed in a Class I, Division 2 hazardous location, you must either:
 - Use a switch located outside the hazardous environment, or
 - Use a switch certified for Class I, Division 1 operation inside the hazardous area.
- Do not connect or disconnect equipment unless power has been switched off or the area is known to be non-hazardous. This applies to all connections including power, ground, serial, parallel, network, and rear USB connections.
- Never use unshielded / ungrounded cables in hazardous locations.
- When enclosed, keep enclosure doors and openings closed at all times to avoid the accumulation of foreign matter inside the workstation.
- Do not use front USB and keep the cover in place.
- Do not expose to direct sunlight or UV light source.

Failure to follow these instructions will result in death or serious injury.

DANGER

HAZARD OF ELECTRIC SHOCK, EXPLOSION OR ARC FLASH

- Remove all power from the device before removing any covers or elements of the system, and prior to installing or removing any accessories, hardware, or cables.
- Unplug the power cable from both the Box and the power supply.
- Always use a properly rated voltage sensing device to confirm power is off.
- Replace and secure all covers or elements of the system before applying power to the unit.
- Use only the specified voltage when operating the Box. The AC unit is designed to use 100...240 Vac input. The DC unit is designed to use 24 Vdc input. Always check whether your device is AC or DC powered before applying power.

Failure to follow these instructions will result in death or serious injury.

Ensure that the product is properly rated for the location. If the intended location does not presently have a Class, Division and Group rating, then users should consult the appropriate authorities having jurisdiction in order to determine the correct rating for that hazardous location.

In accordance with Federal, State/Provincial, and Local regulations, all hazardous location installations should be inspected prior to use by the appropriate authority having jurisdiction. Only technically qualified personnel should install, service, and inspect these systems.

Power Switch

DANGER

HAZARD OF ELECTRIC SHOCK, EXPLOSION OR ARC FLASH

- Remove all power from the device before removing any covers or elements of the system, and prior to installing or removing any accessories, hardware, or cables.
- Unplug the power cable from both the Box and the power supply.
- Always use a properly rated voltage sensing device to confirm power is off.
- Replace and secure all covers or elements of the system before applying power to the unit.
- Use only the specified voltage when operating the Box. The AC unit is designed to use 100...240 Vac input. The DC unit is designed to use 24 Vdc input. Always check whether your device is AC or DC powered before applying power.

Failure to follow these instructions will result in death or serious injury.

The amount of input power required by systems with a Box classifies the power switch as an incendive device because the voltage and current across the make/break component are capable of generating a spark.

If using an ordinary power switch, hazardous location regulations require the power switch be located in an area specified as non-hazardous.

However, limits in cable length between the workstation and the power switch may apply. Otherwise the switch must be compliant with Class I, Division 1 requirements (intrinsically safe). These switches are built in a manner that prevents the possibility of a spark when contact is made or broken.

Use suitable UL listed and/or CSA Certified Class I, Division 1 switches in hazardous locations. These switches are available from a wide number of sources. It is your responsibility to ensure that you select a power switch that conforms to the hazardous location rating for the installation.

Cable Connections

DANGER

POTENTIAL FOR EXPLOSION

- Always confirm the ANSI/ISA 12.12.01 and CSA C22.2 N°213 hazardous location rating of your device before installing or using it in a hazardous location.
- To power on or power off a Box installed in a Class I, Division 2 hazardous location, you must either:
 - Use a switch located outside the hazardous environment, or
 - Use a switch certified for Class I, Division 1 operation inside the hazardous area.
- Do not connect or disconnect equipment unless power has been switched off or the area is known to be non-hazardous. This applies to all connections including power, ground, serial, parallel, network, and rear USB connections.
- Never use unshielded / ungrounded cables in hazardous locations.
- When enclosed, keep enclosure doors and openings closed at all times to avoid the accumulation of foreign matter inside the workstation.
- Do not use front USB and keep the cover in place.
- Do not expose to direct sunlight or UV light source.

Failure to follow these instructions will result in death or serious injury.

Division 2 hazardous location regulations require that all cable connections be provided with adequate strain relief and positive interlock. Use only non-incendive USB devices as USB connections do not provide adequate strain relief to allow the use of Box USB connections. Never connect or disconnect a cable while power is applied at either end of the cable. All communication cables should include a chassis ground shield. This shield should include both copper braid and aluminum foil. The D-Sub style connector housing must be a metal conductive type (for example, molded zinc) and the ground shield braid must be terminated directly to the connector housing. Do not use a shield drain wire.

The outer diameter of the cable must be suited to the inner diameter of the cable connector strain relief so that a reliable degree of strain relief is maintained. Always secure the D-Sub connectors to the workstation-mating connectors via the two screws located on both sides.

Operation and Maintenance

The systems have been designed for compliance with relevant spark ignition tests for the front USB connection only.

DANGER

POTENTIAL FOR EXPLOSION

In addition to the other instructions in this manual, observe the following rules when installing the Box in a hazardous location:

- Wire the equipment in accordance with the National Electrical Code article 501.10 (B) for Class I, Division 2 hazardous locations.
- Install the Box in an enclosure suitable for the specific application, which can only be opened by using a tool-secured enclosure. Type 4 or IP65 enclosures are recommended even when not required by regulations.

Failure to follow these instructions will result in death or serious injury.

NOTE: IP65 is not part of UL certification for hazardous locations.

Chapter 2

Physical Overview

Subject of this Chapter

This chapter provides a physical overview of the Box.

What Is in This Chapter?

This chapter contains the following topics:

Topic	Page
Package Contents	22
Box Celeron and Box Core i7 Description	25
Display Module Description	30
Display Adapter Description and Configuration	33

Package Contents

Items of The Box

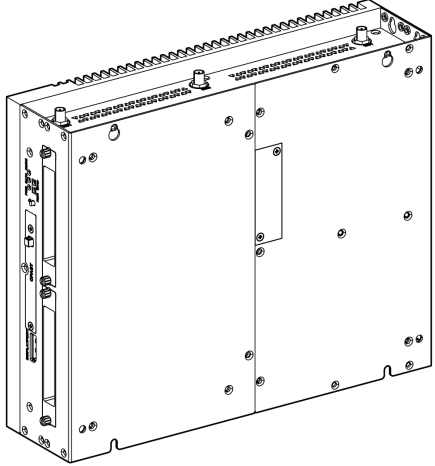
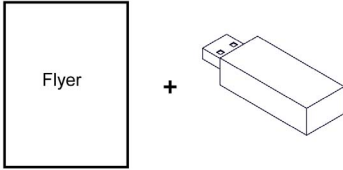
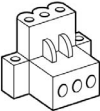
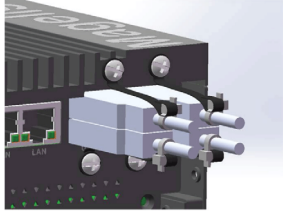

The following items are included in the package of the Box. Before using the Box, confirm that all items listed here are present:

<p>Box</p>	
<ul style="list-style-type: none"> ● Recovery media containing the software required to reinstall the operating system (Microsoft Windows EULA). Additional drivers are in the recovery media ● Chinese user manual ● "Before using this product" flyer ● Warning/Caution information ● Chinese RoHS flyer 	
<ul style="list-style-type: none"> ● 1 x DC terminal block: 3-pin power connector ● 1 x wire for chassis ground ● 8 x screws for mounting the HDD/SSD (not included when 2 x HDD/SSD pre-mounted, 4 x screws when 1 x HDD/SSD pre-mounted) ● 4 x black screws for mounting the Display Module (not included when the Display Module is delivered pre-mounted on Box). 	
<p>Flexible USB holder:</p> <ul style="list-style-type: none"> ● 4 x metal cable tie ● 4 x screws ● 4 x plastic cable tie 	

The Box has been carefully packed, with special attention to quality. However, should you find anything damaged or missing, contact your local distributor immediately.

Items of The Display Module

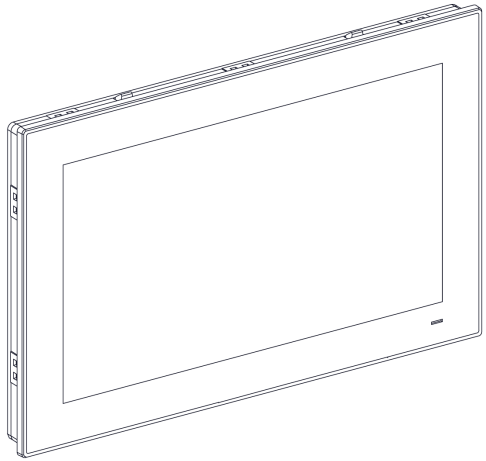
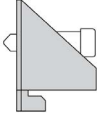
The following items are included in the package of the Display Module. Before using the Display Module, confirm that all items listed here are present:

Display Module	
<ul style="list-style-type: none"> ● 10 x installation fasteners for Display Module 15" single touch and W15" multi-touch (10 x screws, 10 x brackets) ● 12 x installation fasteners for Display Module W19" multi-touch and W22" multi-touch (12 x screws, 12 x brackets) ● 1 x panel gasket 	
<ul style="list-style-type: none"> ● "Before using this product" flyer ● Warning/Caution information ● Chinese RoHS flyer 	

The Display Module has been carefully packed, with special attention to quality. However, should you find anything damaged or missing, contact your local distributor immediately.

Items of The Display Adapter

The following items are included in the package of the Display Adapter. Before using the Display Adapter, confirm that all items listed here are present:

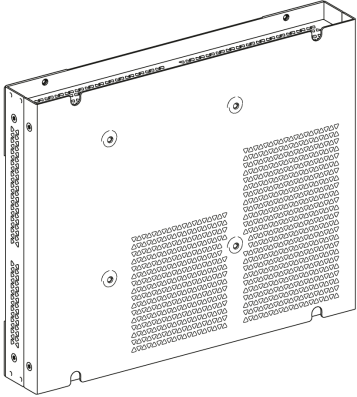
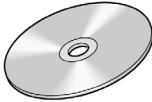
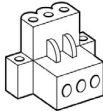
<p>Display Adapter</p>	
<ul style="list-style-type: none"> ● The media containing the drivers and the user manual to setup the Display Adapter ● Chinese user manual ● “Before using this product” flyer ● Warning/Caution information ● Chinese RoHS flyer 	
<ul style="list-style-type: none"> ● 1 x DC terminal block: 3-pin power connector ● 1 x wire for chassis ground ● 4 x black screws for Display Module mounting (not included when Display Module pre-mounted) ● 4 x screws for VESA mounting ● 1x plastic cable tie ● 1x plastic cable clip 	

The Display Adapter has been carefully packed, with special attention to quality. However, should you find anything damaged or missing, contact your local distributor immediately.

Box Celeron and Box Core i7 Description

Introduction

During operation, the surface temperature of the heat sink may exceed 70 °C (158 °F).

 WARNING
<p>RISK OF BURNS</p> <p>Do not touch the surface of the heat sink during operation.</p> <p>Failure to follow these instructions can result in death, serious injury, or equipment damage.</p>

Box 0-Slot Description

Overview

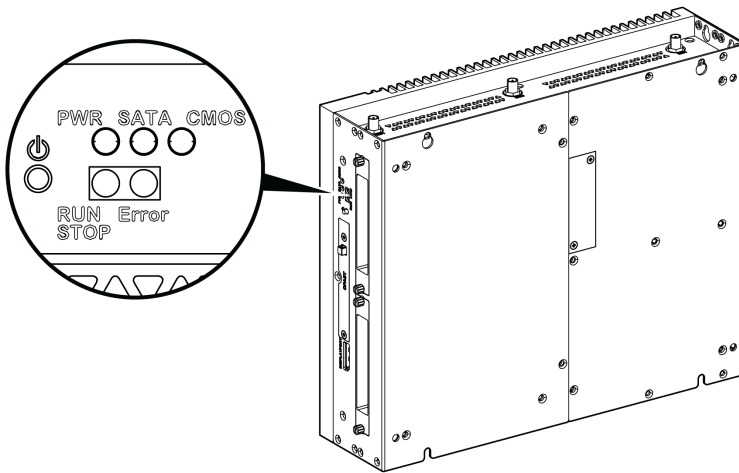

Power ON/OFF button and LEDs

The table describes the meaning of the status indicators:

Marking	LED	Color	State	Meaning
PWR	Power	Orange	On	Stand by.
		Green	On	Box is OK.
		–	Off	Box is off.
SATA	SATA	Green	Off	Storage data does not transmit.
			On	Storage data transmit.
CMOS	Battery	Orange	On	RTC voltage < 3 Vdc.
		–	Off	RTC voltage > 3 Vdc.
Programmable LED for optional control software				
RUN/STOP	RUN/STOP from control software	Red	Off	Stop.
		Green	On	Run.
ERR	Error from control software	–	Off	Control software has not error.
		Red	On	Control software has error.

Front View

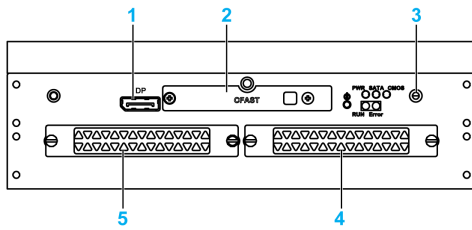

- 1 DisplayPort 2
- 2 Slide-in CFast slot
- 3 LEDs and power/reset button
- 4 HDD/SSD 1 (hot swap and can be RAID configuration)
- 5 HDD/SSD 2 (hot swap and can be RAID configuration)

Top View

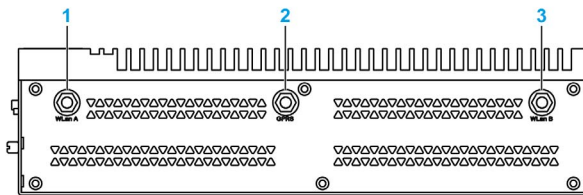

- 1 SMA connector for the wireless LAN external antenna
- 2 SMA connector for the GPRS external antenna
- 3 SMA connector for the wireless LAN external antenna

Bottom View

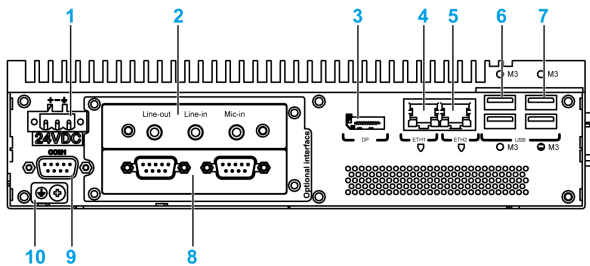

- 1 DC power connector
- 2 Optional interface 1
- 3 DisplayPort 1
- 4 Eth1 (10/100/1000 Mbit/s) IEEE1588
- 5 Eth2 (10/100/1000 Mbit/s) IEEE1588
- 6 USB1 and USB2 (USB 3.0)
- 7 USB3 and USB4 (USB 2.0)
- 8 Optional interface 2
- 9 COM1 port RS-232, RS-422/485 (isolated)
- 10 Ground connection pin

Box 2-Slot Description

Overview

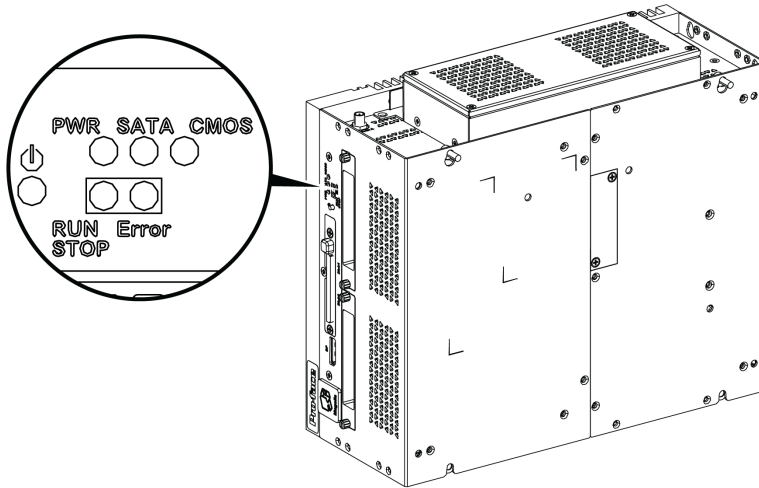

Power ON/OFF button and LED

The table describes the meaning of the status indicators:

Marking	LED	Color	State	Meaning
PWR	Power	Orange	On	Stand by.
		Green	On	Box is OK.
		–	Off	Box is off.
SATA	SATA	Green	Off	Storage data does not transmit.
			On	Storage data transmit.
CMOS	Battery	Orange	On	RTC voltage < 3 Vdc.
		–	Off	RTC voltage > 3 Vdc.
Programmable LED for optional control software				
RUN/STOP	RUN/STOP from control software	Red	Off	Stop.
		Green	On	Run.
ERR	Error from control software	–	Off	Control software has not error.
		Red	On	Control software has error.

Front View

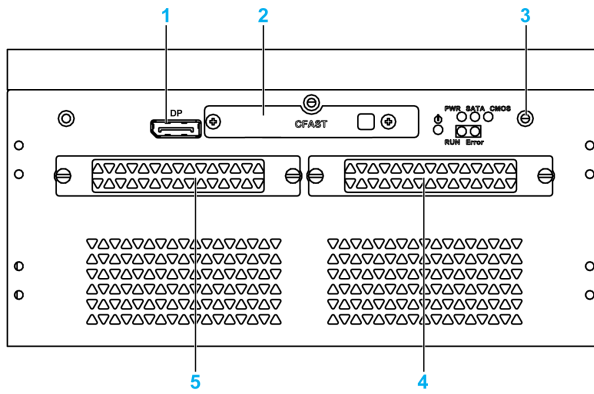

- 1 DisplayPort 2
- 2 Slide-in CFast slot
- 3 LEDs and power/reset button
- 4 HDD/SSD 1 (hot swap and can be RAID configuration)
- 5 HDD/SSD 2 (hot swap and can be RAID configuration)

Top View

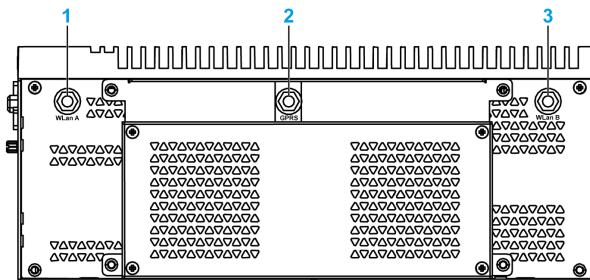

- 1 SMA connector for the wireless LAN external antenna
- 2 SMA connector for the GPRS external antenna
- 3 SMA connector for the wireless LAN external antenna

Bottom View

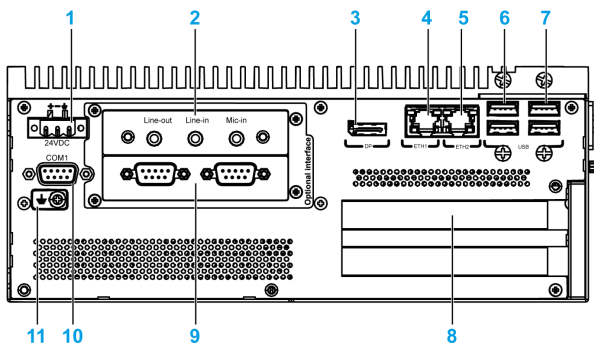

- 1 DC power connector
- 2 Optional interface 1
- 3 DisplayPort 1
- 4 Eth1 (10/100/1000 Mbit/s) IEEE1588
- 5 Eth2 (10/100/1000 Mbit/s) IEEE1588

- 6 USB1 and USB2 (USB 3.0)
- 7 USB3 and USB4 (USB 2.0)
- 8 PCI or PCIe (peripheral component interconnect express) slots
- 9 Optional interface 2
- 10 COM1 port RS-232, RS-422/485 (isolated)
- 11 Ground connection pin

Box and Display Module Description

Overview

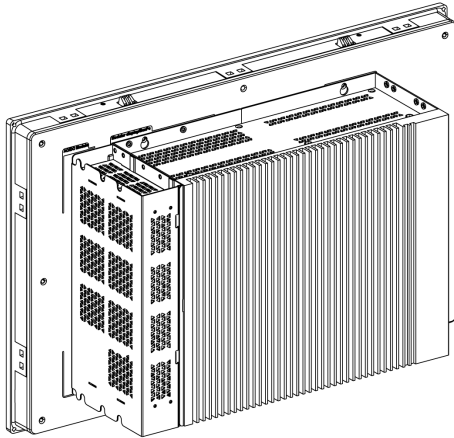

NOTE: The Box can support two display ports. When the Box is mounted with the Display Module, the DisplayPort 2 has no function.

NOTE: After DisplayPort cable is plugged, Operating System must be reboot.

NOTE: For connecting the Box on display with DVI interface, use DP to DVI cable: PFXZPBCB-DPDV32 (see in accessories (*see page 205*)).

Bottom View

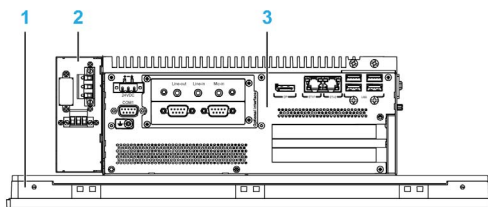

- 1 Display Module
- 2 Optional AC power supply module (PFXZPBUAC2)
- 3 Box

Display Module Description

Front View Display Module 15" single touch

The Display Module 15" single touch has a touch screen with analog-resistive touch technology that may operate abnormally when two or more points are simultaneously used.

⚠ WARNING
UNINTENDED EQUIPMENT OPERATION Do not touch two or more points simultaneously on display. Failure to follow these instructions can result in death, serious injury, or equipment damage.

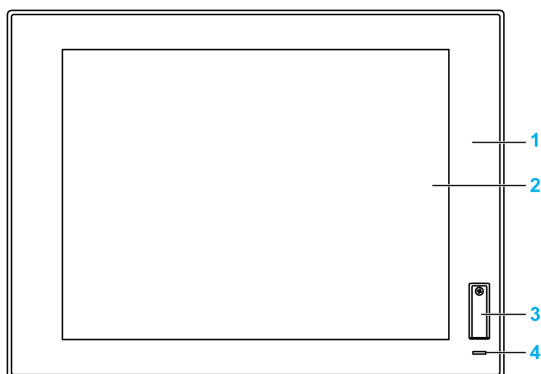

- 1 Panel (15" single touch)
- 2 single-touch panel
- 3 USB port (USB 2.0)
- 4 Status indicator

NOTE: The front USB is a diagnostic interface for service and maintenance.

⚠ WARNING
UNINTENDED EQUIPMENT OPERATION <ul style="list-style-type: none">● Do not use the front USB while the machine is in operation.● Always keep the cover in place during normal operation. Failure to follow these instructions can result in death, serious injury, or equipment damage.

Front View Display Module W15" multi-touch or W19" multi-touch or W22" multi-touch

The Display Module W15", W19" and W22" multi-touch have a touch screen with projected capacitive touch technology that may operate abnormally when the surface is wet.

⚠ WARNING

LOSS OF CONTROL

- Do not touch the touch screen area during Operating System startup.
- Do not operate when the touch screen surface is wet.
- If the touch screen surface is wet, remove any excess water with a soft cloth before operation.
- Make sure to use only the authorized grounding configurations shown in the grounding procedure.

Failure to follow these instructions can result in death, serious injury, or equipment damage.

NOTE:

- The touch control is disabled in case of abnormal touch (like water) for a few seconds to avoid accidental touch. The normal touch function will be recovered a few seconds after removing the abnormal touch condition.
- Do not touch the touch screen area during Operating System startup since "touch panel firmware" initializes automatically when Windows starts up.

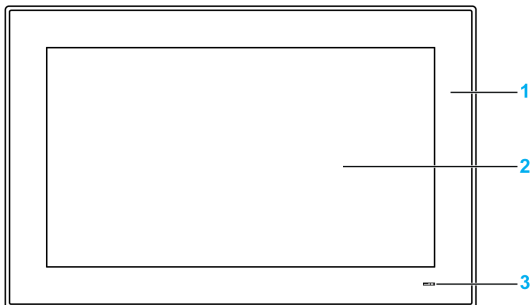

- 1 Panel (W15" multi-touch or W19" multi-touch or W22" multi-touch)
- 2 Multi-touch panel
- 3 Status indicator

Status Indicator

The table describes the meaning of the status indicator:

Color	State	Meaning
Orange	On	Stand by.
Blue	On	Supply voltage is OK.
–	Off	Supply voltage is off.

Rear View

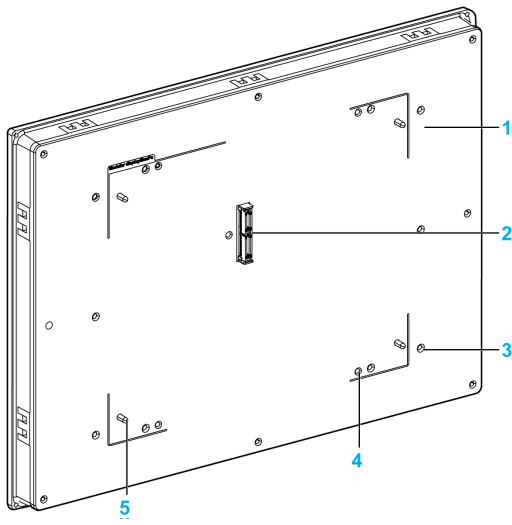

- 1 Panel
- 2 Panel connector for the Box
- 3 Mounting holes for the VESA kit
- 4 Mounting holes for the Box
- 5 Panel guide for the Box

Display Adapter Description and Configuration

Overview

The Display Module can be mounted remotely from the Box, thanks to Display Adapter.

The Display Adapter can be connected to any PC with USB cable for touch screen and Display Port cable for video, with a maximum distance of 5 m.

When equipped with Receiver and Transmitter, up to 4 Display Adapters can be connected to one Box equipped with Optional Interface for RJ45 cable. In this configuration, the single RJ45 cable supports both touch screens and video signal for a maximum distance of 100 m between devices, so maximum 400 m total for 4 Display Modules.

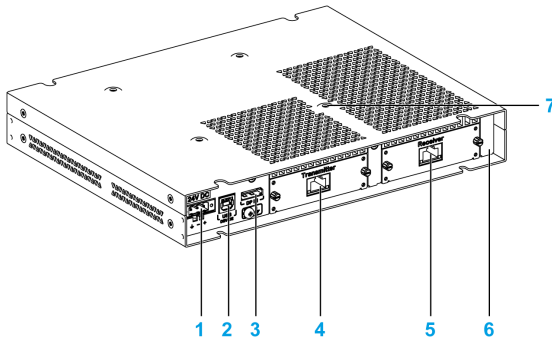

- 1 DC power supply connection
- 2 USB port (USB 2.0 for touch screen OUT, when Display port IN is used)
- 3 Display Port (IN)
- 4 Transmitter (PFXZPPDMPTX2) with RJ45 port (pending)
- 5 Receiver (PFXZPPDMPRX2) with RJ45 port (pending)
- 6 Display Adapter (PFXZPPDADDP2)
- 7 Mounting holes for the VESA

For hazardous location, the AC power supply module (PFXZPBPUAC2) must be mounted on the Display Adapter (PFXZPPDADDP2) to be operated with 100...240 Vac.

Configuration for Display Port Connection (Maximum Distance: 5 m)

Step	Action
1	<p>Connect the Display Adapter to local PC through DP cable:</p> <p>1 Display Adapter 2 Display Module 3 USB cable 5 m (FP-US00) 4 DP to DP cable 5 m (PFXZPBCBDP52)</p> <p>NOTE: The length of the DP cable is limited to 5 m (16.40 ft).</p>
2	<p>Connect the Display Adapter to a local PC through USB cable to use Touch function (<i>see page 36</i>).</p> <p>NOTE: The length of the USB cable is limited to 5 m.</p>
3	<p>Install touch driver by installer from either USB memory key of box or DVD of Display Adapter.</p>

Configuration for RJ45 Cable with Receiver and Transmitter (Maximum Distance: 100 m) (Pending)

The Receiver and Transmitter solution can be used to connect multiple Display Modules in a daisy chain manner. The Display Adapter is connected to the Box by RJ45 cables (type CAT6) with a maximum distance of 100 meters between 2 devices.

The Box can support data transfer with four Display Modules that have a Display Adapter, so with a maximum distance up to $4 \times 100 \text{ m} = 400 \text{ m}$ (437 yd). The four Display Modules are clone Display Modules. The default resolution from mini PCIe is 1080 pixels and each display on RX/TX chain is scaled down to the resolution of the Display Module.

NOTE: When W22" multi-touch Display Module is connected in one of multiple displays, the resolution is exact 1080 pixels. When W19" multi-touch/W15" multi-touch is connected, the resolution is still 1080 pixels but fit into WHD/FWXGA. If 15" single touch Display Module is connected, 1080 pixels resolution is fitted into XGA.

The touch panel of the Display Module is single use at a time and need waiting until finger leave; then other touch panels can work (waiting time 100 ms).

The remote Box shares video signals thanks to an optional Transmitter for PS5000 (PFXZPBMPX2).

NOTE: When the Receiver is connected, the local connection with the host using DP and USB cables is disabled and the remote PC screen appears. But when the Receiver cable from the Box interface is disconnected, it switches automatically to local PC screen.

NOTE: In this configuration, a PC cannot be used for the connection with Display Adapter.

NOTE: For the installation of Transmitter and Receiver, refer to Display Module and Display Adapter Installation (*see page 63*)

Follow these steps for Display Module and Display Adapter Installation:

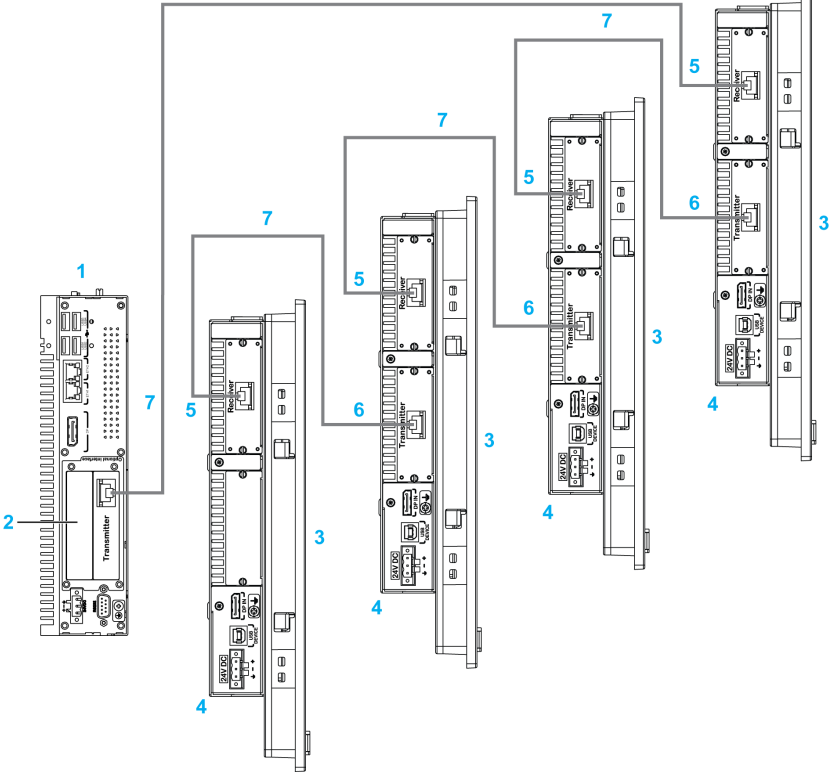
Step	Action
1	<p data-bbox="326 253 994 278">Connect the Display Adapter to Box through RJ45 cables (type CAT6):</p>  <p data-bbox="326 1087 683 1271"> 1 Box 2 Transmitter for PS5000 (pending) 3 Display Module 4 Display Adapter 5 Receiver (pending) 6 Transmitter (pending) 7 RJ45 cables (type CAT6) </p> <p data-bbox="326 1296 865 1321">NOTE: The length of the RJ45 cable is limited to 100 m.</p> <p data-bbox="326 1335 1252 1387">NOTE: For the connection with the Display Adapter, do not connect a RJ45 cable to an Ethernet port on the Box.</p>
2	<p data-bbox="326 1402 971 1427">Install the driver of Transmitter for PS5000 with following procedure:</p> <ol data-bbox="326 1431 1236 1580" style="list-style-type: none"> <li data-bbox="326 1431 985 1456">1. BIOS Graphic of Box setting to IGFX before install the Transmitter. <li data-bbox="326 1460 1222 1512">2. Install the Transmitter on system Box, power on system into the windows install its driver by installer from USB memory key of Box or DVD of Display Adapter. <li data-bbox="326 1516 1236 1568">3. Use CAT6 cable link Transmitter and Display Adapter Receiver, Transmitter link next Display Adapter receiver module (max link four PCs Display Adapter). <li data-bbox="326 1572 1030 1597">4. In accordance with the order power on Display Adapter (1 → 2 → 3 → 4).

NOTE: When the Receiver is installed, the display port **DP In** has no function for Display Module.

Touch Function Behavior

For each Display Module, a software tool is available to enable/disable touch-panel operation. The user can disable 3 other touch panels to monopolize the touch operation, the display order must match the utility. The exclusive **Touch** function is set to be effective for 100 ms even after a finger leaves the Display Module.

NOTE: Without the tool, the behavior in default is user touch one of the Display Modules disables other three Display Modules.

BIOS Graphic setting to IGFX before install Transmitter for PS5000 into Box:

1. BIOS - Chipset - System Agent (SA) Configuration
2. Graphics Configuration
3. Primary Display - IGFX
4. Save and exit BIOS

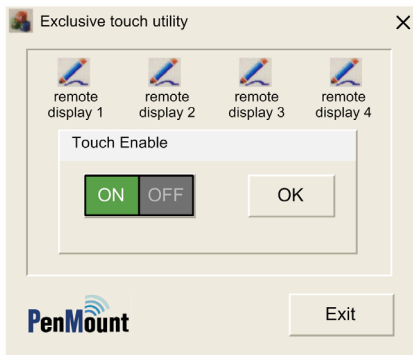
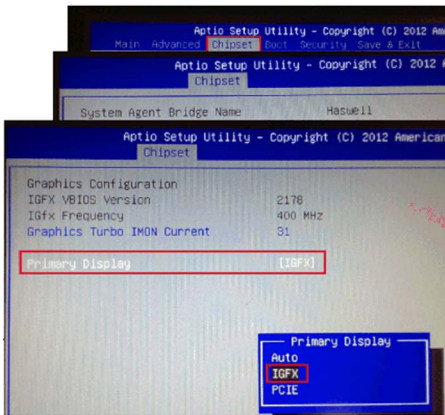

NOTE: Exclusive touch utility cannot turn off the touch panel itself when operate to prevent mis-operate.

NOTE: This utility is stored in DVD of Display Adapter or USB key.

Chapter 3

Characteristics

Subject of this Chapter

This chapter lists the product characteristics.

What Is in This Chapter?

This chapter contains the following topics:

Topic	Page
Box Characteristics	38
Display Characteristics	40
Display Adapter and Receiver / Transmitter Characteristics	41
Power Supply Characteristics	43
Environmental Characteristics	44

Box Characteristics

Characteristics

Element	Characteristics	
	Box Core i7	Box Celeron
Intel chipset and processor	Core i7-4650U 1.7 GHz	Celeron 2980U 1.6 GHz
Expansion slot	0-Slot: 2 x mini PCIe full size 2-Slot: <ul style="list-style-type: none"> ● 2 x mini PCIe full size and 1 x PCI + 1 x PCIe x4 ● 2 x mini PCIe full size and 2 x PCI ● 2 x mini PCIe full size and 1 x PCIe x1 + 1 x PCIe x4 Compliant with PCI Express 3.0 half size and PCI 2.2 half size.	
Memory	8 GB or 16 GB, DDR3L 1600 MHz, SO-DIMM SDRAM	4 GB or 8 GB, DDR3L 1600 MHz, SO-DIMM SDRAM
	512 KB MRAM for the user Read/Write speed: 35 ns	
Storage memory	2 x SATA connectors, 1 x CFAST slot, 1 x mSATA slot	
Watch dog timer	255 level timer interval, programmable 1...255 sec/min (setting through API)	
Buzzer	Yes	
Cooling method	Passive heat sink	
Weight (without HDD / CFAST / mini card / PCIe card / PCI card)	0-Slot: 3.1 kg (6.8 lbs)	0-Slot: 3.1 kg (6.8 lbs)
	2-Slot: 3.9 kg (8.6 lbs)	2-Slot: 3.9 kg (8.6 lbs)

MRAM Memory

The Box supported on board non-volatile memory, it is using MRAM technology for this feature; it offers SRAM compatible 35 ns read/write timing with unlimited endurance. The data is always non-volatile for greater than 20-years. The data is automatically protected on power loss by low-voltage inhibit circuitry to prevent writes with voltage out of specification.

Watchdog Timer

The watchdog timer is used to generate a system reset. The watchdog timer is programmable, with each unit equal to 1 second or 1 minute with 255 levels.

Serial Interface

Element	Characteristics
Type	RS-232, RS-422/485 (COM1), with auto data flow control, modem-capable, electrically isolated
Amount	1
Transfer rate	Maximum 115.2 kbps
Connection	D-Sub 9-pin, plug

USB Interface

Element	Characteristics
Type	2 x USB 3.0 and 2 x USB 2.0
Amount	4
Transfer rate	Low speed (1.5 Mbit/s), full speed (12 Mbit/s), high speed (480 Mbit/s) and super speed (5 Gbit/s) (USB 3.0 port only)
Current load	Maximum 1 A per connection
Connection	Type A

Ethernet Interface

Element	Characteristics
Type	RJ45
Amount	2
Speed	10/100/1000 Mbit/s base-T
Ethernet controller	I210, supporting IEE1588

DisplayPort

Element	Characteristics
Type	DisplayPort connector (when converting to DVI, DP to DVI adapter PFXZPBADCVDPDV2 or cable is required)
Amount	2
Resolution (DisplayPort 1/DisplayPort 2)	Supports up to 3200 x 2000 at 60 Hz

NOTE: The Box can support two display ports. When the Box is mounted with the Display Module, the **DisplayPort 2** has no function.

NOTE: After DisplayPort cable is plugged, Operating System must be reboot.

NOTE: I/O ports (such as serial, USB, and Ethernet interfaces) on this product have internal port numbers that may differ from physical port numbers, such as **COM1**, **USB1** or **ETH1**, printed on the product and used for identification in this manual. Check the port numbers in your environment.

Operating Systems

Each product is delivered with a preinstalled operating system according to the configuration:

Operating systems
Windows Embedded 8.1 Industry 64 bits MUI
Windows 7 Ultimate SP1 64 bits MUI
Windows Embedded Standard 7 (WES7P) SP1 64 bits MUI

NOTE: All products with Windows 8 must be connected to the internet during the first start-up for the operating system to activate.

Display Characteristics

Characteristics

Element	15" single touch screen size	W15" multi-touch screen size	W19" multi-touchscreen size	W22" multi-touch screen size
Type	TFT LED LCD			
Size	15" square 4:3	15.6" wide 16:9	18.5" wide 16:9	21.5" wide 16:9
Resolution (pixel)	XGA 1024 x 768	WHD/FWXGA 1366 x 768	WHD/FWXGA 1366 x 768	Full HD 1920 x 1080
Number of colors	16.7 million			
Brightness control	Step less adjustment			
Backlight life	Life span > 50,000 h @ 25 °C (77 °F)			
Touch screen	Resistive single touch	Capacitive multi-touch 5 simultaneous touch (projected capacitive)		
Touch screen resolution (pixel)	2048 x 2048	4096 x 4096		
Front access	1 x USB2.0 1 x reset button	–	–	–
International protection	IP 66 / Nema 4x indoor			
Weight	4.2 kg (9.2 lbs)	4.3 kg (9.5 lbs)	5.2 kg (11.5 lbs)	6.6 kg (14.5 lbs)

USB Interface Front Panel for the Display Module 15" single touch

Element	Characteristics
Type	USB 2.0
Amount	1
Transfer rate	Low speed (1.5 Mbit/s), full speed (12 Mbit/s), and high speed (480 Mbit/s)
Current load	Maximum 0.5 A per connection
Connection	Type A

Display Adapter and Receiver / Transmitter Characteristics

Display Adapter Characteristics

Element	Characteristics
Cooling method	Passive heat sink
Weight (without Receiver / Transmitter)	1.8 Kg (3.96 lb)
Weight (with Receiver / Transmitter)	2.4 Kg (5.29 lb)

Display Adapter USB Interface

Element	Characteristics
Type	USB 2.0, type B
Amount	1
Transfer rate	Low speed (1.5 Mbit/s), full speed (12 Mbit/s), high speed (480 Mbit/s)
Current load	0.5 A for USB 2.0

Display Adapter DisplayPort

Element	Characteristics
Type	DisplayPort connector
Amount	1

NOTE: For connecting the Display Adapter and the Box or a PC, use DP and USB cables: PFXZPBCBDP52 and FP-US00, see in accessories (*see page 205*).

Receiver (PFXZPPDMPRX2)

Element	Characteristics
Dimension	120 x 77.4 x 33.8 mm (4.72 x 3.05 x 1.33 in)
Power consumption	5 W
Point-to-point transmit	100 m (328 ft)
Connector	RJ45 port x 1
Cable specification	CAT6
Optional temperature	0...55 °C (131 °F)

NOTE: When the Receiver is connected, the local connection with the host using DP and USB cables are disabled and the remote PC screen appears. However, when the Receiver from the Box interface is disconnected, it switches automatically to local PC screen.

Transmitter (PFXZPPDMPTX2)

Element	Characteristics
Dimension	80 x 77.4 x 33.8 mm (4.72 x 3.05 x 1.33 in)
Power consumption	3.5 W
Point-to-point transmit	100 m (328 ft)
Connector	RJ45 port x 1
Cable specification	CAT6
Optional temperature	0...55 °C (131 °F)

NOTE:

1. When using a long-distance cable (100 m), the touch beep sound on the display side cannot be heard because the buzzer is on the Box side.
2. For long distance, the Display Adapter (DA) must be connected to modular Display Module (DM) which the Product Version (PV) has to be PV 02 or later (see PV on the DM label).
3. For long distance, the DM supports only 2D graphics because the Transmitter for PS5000 (PFXZPBMPX2) does not support 3D graphics (such as OpenGL, DirectX, ...).
4. Do not use multiple Display Modules with a mix of 4:3 and 16:9 panel display ratios at the same time. The 4:3 panel experiences some display ratio concerns after it is scaled down because the video source from 1080 pixel (16:9) is scaled down to a 4:3 panel. Use the same panel ratio on multiple Display Modules.
5. The long-distance interface, Transmitter for PS5000 (PFXZPBMPX2), provides a high definition signal type not over IP. So intermediary hub or switch over IP are not suitable for long-distance remote monitors. Only direct connections with Ethernet category 6 cable are suitable between Transmitter for PS5000 and remote monitors.

Power Supply Characteristics

Box DC Power Supply

Element	Characteristics
Rated voltage	24 Vdc (18...36 Vdc)
Inrush current	8.9 A
Power consumption	
Box Core i7 with screen	15" single touch Box: 25.9 W typical, 44.9 W max. W15" multi-touch Box: 27.1 W typical, 46.1 W max. W19" multi-touch Box: 28.4 W typical, 48.1 W max. W22" multi-touch Box: 30.5 W typical, 50.7 W max.
Box Celeron with screen	15" single touch Box: 25.5 W typical, 39.9 W max. W15" multi-touch Box: 26.6 W typical, 40.9 W max. W19" multi-touch Box: 27.9 W typical, 43.1 W max. W22" multi-touch Box: 29.9 W typical, 45.2 W max.
Box Core i7	Box: 18.1 W typical, 38.4 W max.
Box Celeron	Box: 17.8 W typical, 33.6 W max.

Display Adapter DC Power Supply

Element	Characteristics
Rated voltage	24 Vdc
Inrush current	5.3 A
Power consumption	15" single touch Display Adapter: 12.42 W max. W15" multi-touch Display Adapter: 14.68 W max. W19" multi-touch Display Adapter: 17.57 W max. W22" multi-touch Display Adapter: 23.33 W max.
Power consumption with Receiver	15" single touch Display Adapter: 19.05 W max. W15" multi-touch Display Adapter: 21.29 W max. W19" multi-touch Display Adapter: 24 W max. W22" multi-touch Display Adapter: 29.12 W max.
Power consumption with Receiver and Transmitter	15" single touch Display Adapter: 21.25 W max. W15" multi-touch Display Adapter: 23.76 W max. W19" multi-touch Display Adapter: 26.53 W max. W22" multi-touch Display Adapter: 31.48 W max.

Environmental Characteristics

Characteristics

Characteristics	Value
Degree of protection	IP 66 front side of display
Pollution degree	For use in pollution degree 2 environment
Operating temperature	0...55 °C (131 °F) except for Box only: <ul style="list-style-type: none"> ● HDD limited to 45 °C (113 °F) ● 2 x mini PCIe + Display Module limited to 45 °C (113 °F) ● PCI / PCIe limited to 45 °C (113 °F)
Storage temperature	- 30...70 °C (- 22...158 °F)
Operating altitude	2,000 m (6,560 ft) max
Random vibration	5...500 Hz: 2 G _{rms} with SSD or CFAST 5...500 Hz: 1 G _{rms} with HDD
Storage humidity	10...95 % RH at 40 °C (104 °F), no condensation

Chapter 4

Dimensions

Subject of this Chapter

This chapter describes Box, Display Module and Display Adapter dimensions.

What Is in This Chapter?

This chapter contains the following topics:

Topic	Page
Box Dimensions	46
Display Module Dimensions	48
Display Adapter Dimensions	50

Box Dimensions

Box 0-Slot Dimensions

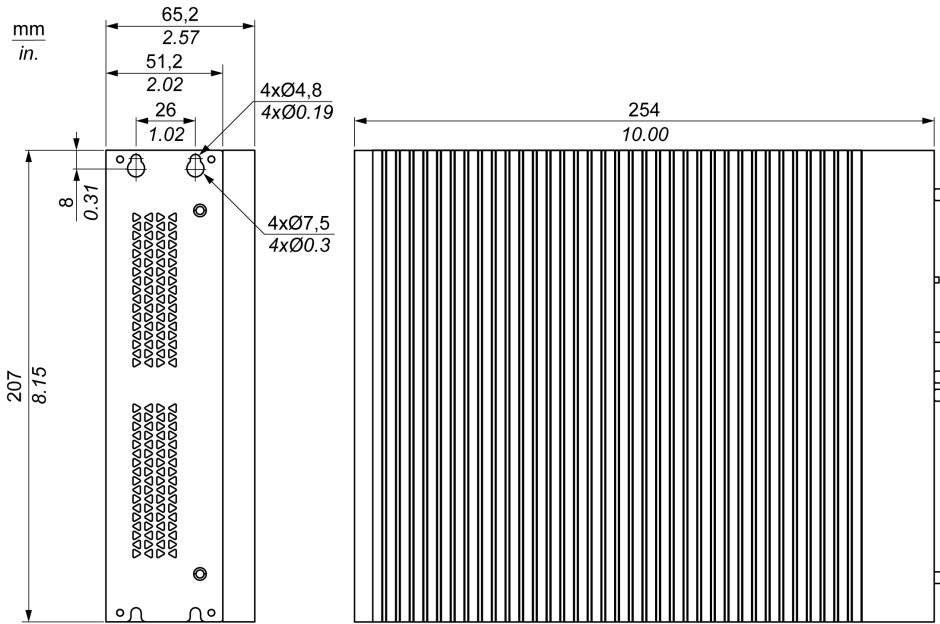

Box 2-Slot Dimensions

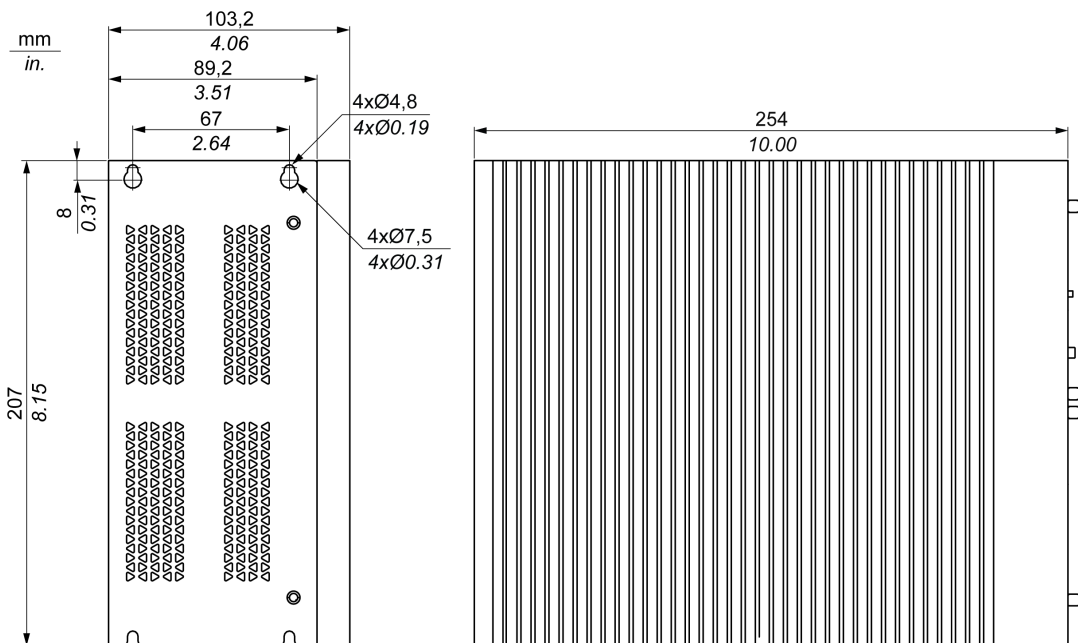

Dimensional Tolerances

The table indicates the general tolerance for the dimensions of the Box:

Nominal measurement range	General tolerance acc. DIN ISO 2768 medium
up to 6 mm (up to 0.236 in)	± 0.1 mm (± 0.004 in)
6...30 mm (0.236...1.181 in)	± 0.2 mm (± 0.0078 in)
30...80 mm (1.181...3.149 in)	± 0.25 mm (± 0.0098 in)
80...180 mm (3.149...7.08 in)	± 0.3 mm (± 0.012 in)
180...400 mm (7.08...15.747 in)	± 0.5 mm (± 0.02 in)

NOTE: For other dimensions of the Box, refer to Pro-face website at <http://www.pro-face.com/trans/en/manual/1001.html>.

Display Module Dimensions

Display Module 15" single touch Dimensions

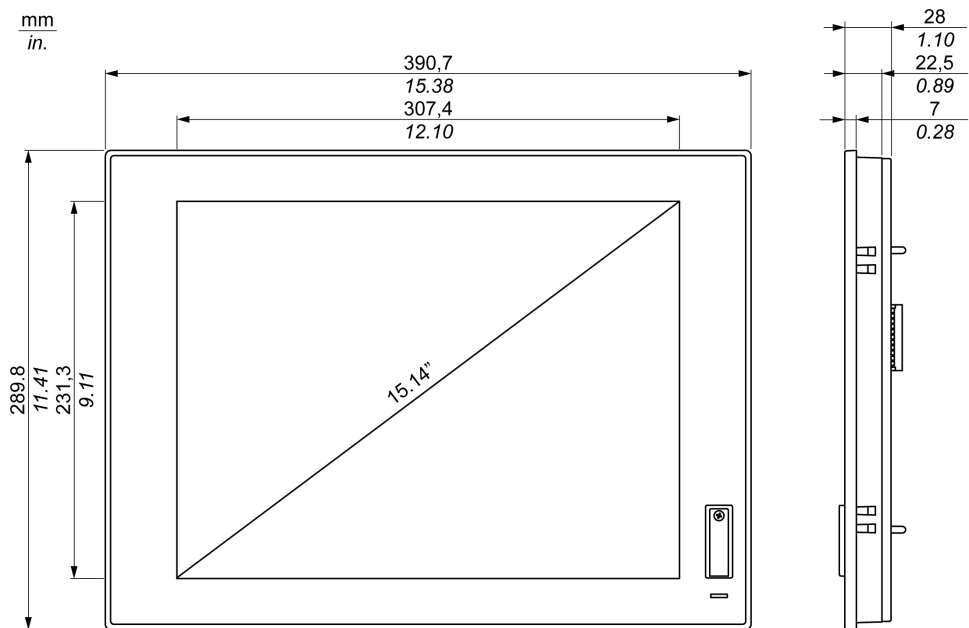

Display Module W15" multi-touch Dimensions

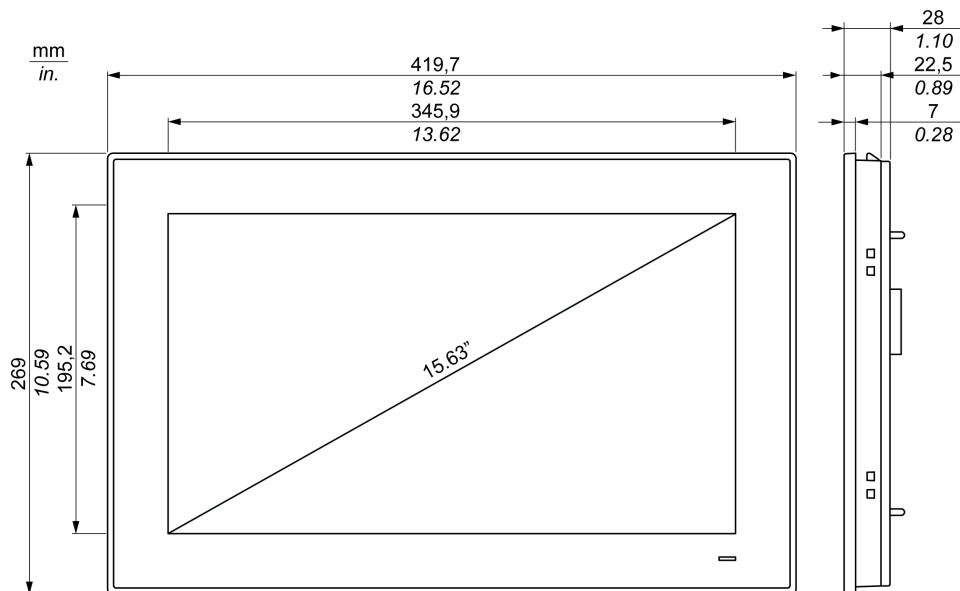

Display Module W19" multi-touch Dimensions

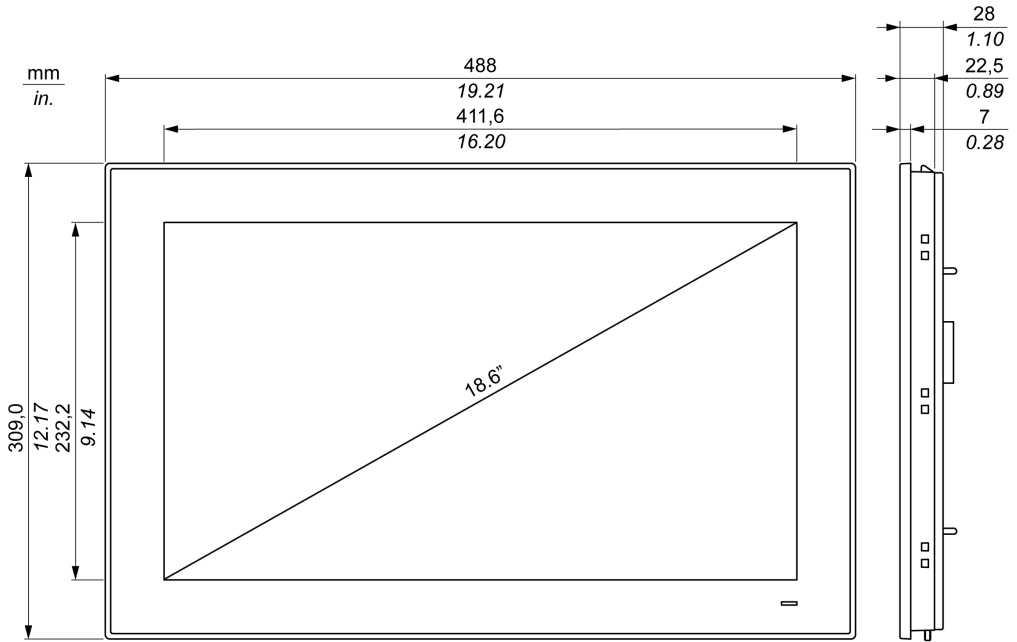

Display Module W22" multi-touch Dimensions

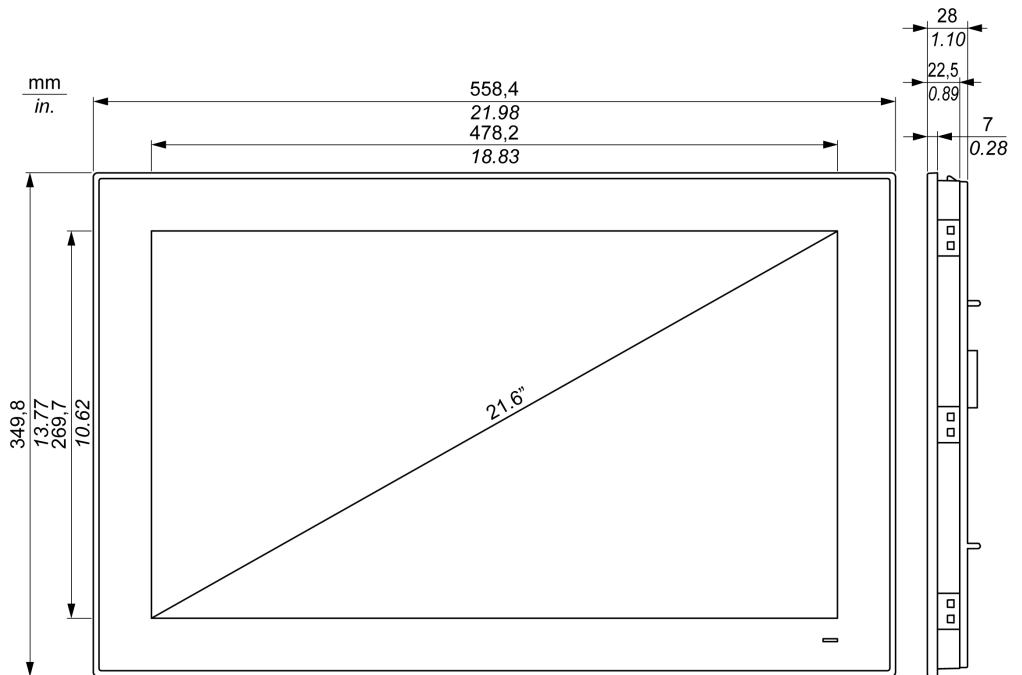

NOTE: For other dimensions of the Display Module, refer to Pro-face website at <http://www.pro-face.com/trans/en/manual/1001.html>.

Display Adapter Dimensions

Dimensions

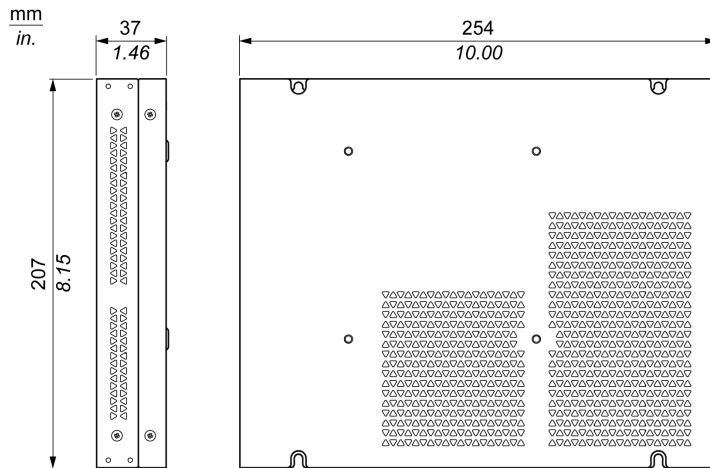

Chapter 5

Installation

What Is in This Chapter?

This chapter contains the following topics:

Topic	Page
Introduction	52
Box Installation	53
Display Module and Box Installation	55
Display Module and Display Adapter Installation	63

Introduction

Overheating of the system can cause incorrect software behavior. To prevent the system from overheating, be aware of the following:

- The environment characteristics of the system must be respected.
- The Box and Display Module are only permitted for operation in closed rooms.
- The Display Module cannot be situated in direct sunlight.
- The Box vent holes must not be covered.
- When mounting the Display Module, observe to the allowed mounting angle.

WARNING

UNINTENDED EQUIPMENT OPERATION

- Do not place the Box next to other devices that might cause overheating.
- Keep the Box away from arc-generating devices such as magnetic switches and non-fused breakers.
- Avoid using the Box in environments where corrosive gases are present.
- Install the Box in a location providing a minimum clearance of 10 mm (0.39 in) or more on the left and right sides, 50 mm (1.96 in) or more on the rear side, and 100 mm (3.93 in) or more above and below the product from all adjacent structures and equipment.
- Install the Box with sufficient clearance for cable routing and cable connectors.

Failure to follow these instructions can result in death, serious injury, or equipment damage.

Box Installation

Mounting Orientation

The following figure shows the allowed mounting orientation for the Box:

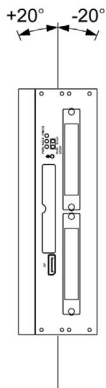

Spacing Requirements

In order to provide sufficient air circulation, mount the Box so that the spacing on the top, bottom, and side is as follows:

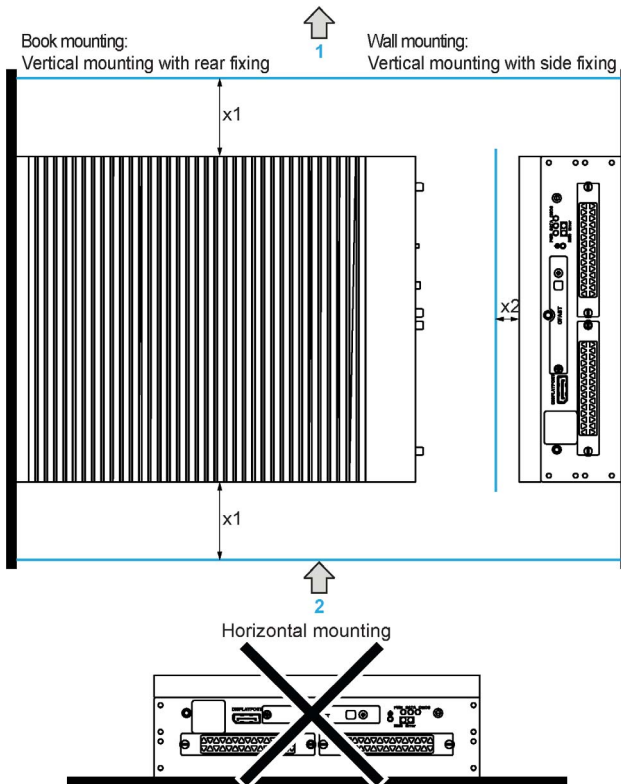

- 1 Air out
- 2 Air in
- x1 > 100 mm (3.93 in)
- x2 > 50 mm (1.96 in)

Installation of the Box

Follow these steps for installation of the Box:

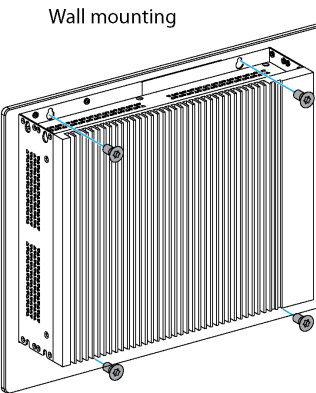
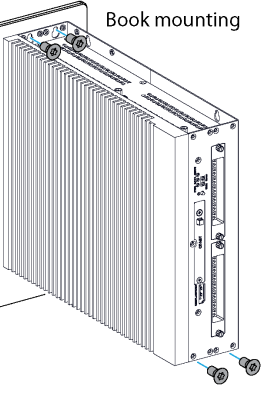
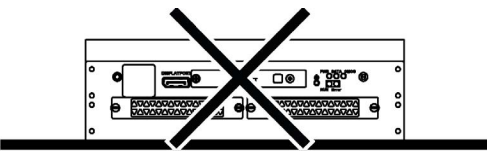
Step	Action
1	Remove all power and confirm that the power supply is disconnected from its power source.
2	Fasten the Box on the vertical side of the cabinet with four screws and four washers:
<div style="display: flex; justify-content: space-around; align-items: center;"> <div style="text-align: center;"> <p>Wall mounting</p>  </div> <div style="text-align: center;"> <p>Book mounting</p>  </div> </div>	
<p>NOTE: The recommended torque to tighten these screws is 0.5 Nm (4.5 lb-in).</p>	
<p>NOTE: The book mounting is not allowed for DNV (Det Norske Veritas) certified configuration.</p>	
<div style="text-align: center;">  </div>	
<p>NOTE: The horizontal mounting is not allowed.</p>	

Display Module and Box Installation

Spacing Requirements

In order to provide sufficient air circulation, mount the Display Module so that the spacing above, below, and on the sides of the unit is as follows:

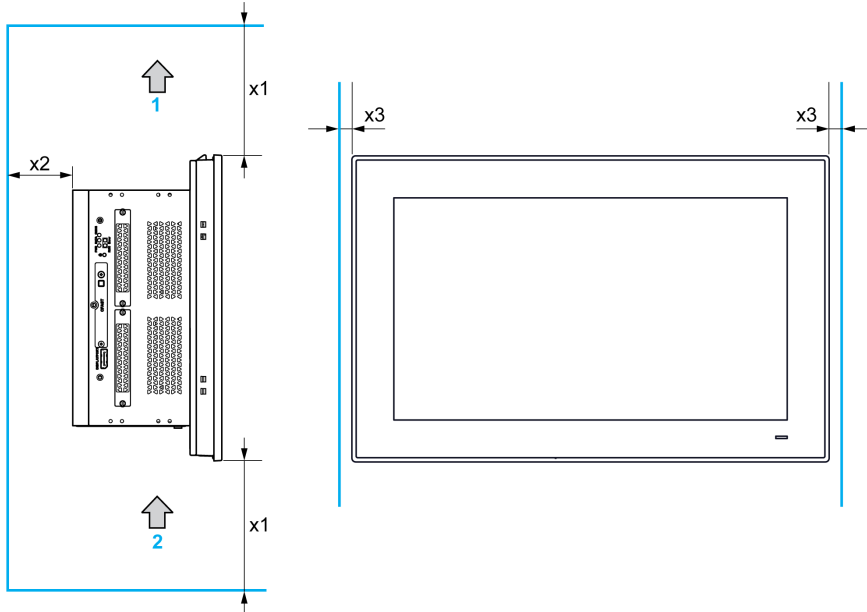

- 1 Air out
- 2 Air in
- $x1$ > 100 mm (3.93 in)
- $x2$ > 50 mm (1.96 in)
- $x3$ > 10 mm (0.39 in)

Mounting Orientation

The following figure shows the allowed mounting orientation for the Display Module:

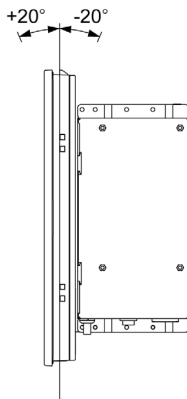

Panel Cut Dimensions

For cabinet installation, you need to cut the correct sized opening in the installation panel according to the model of Display Module.

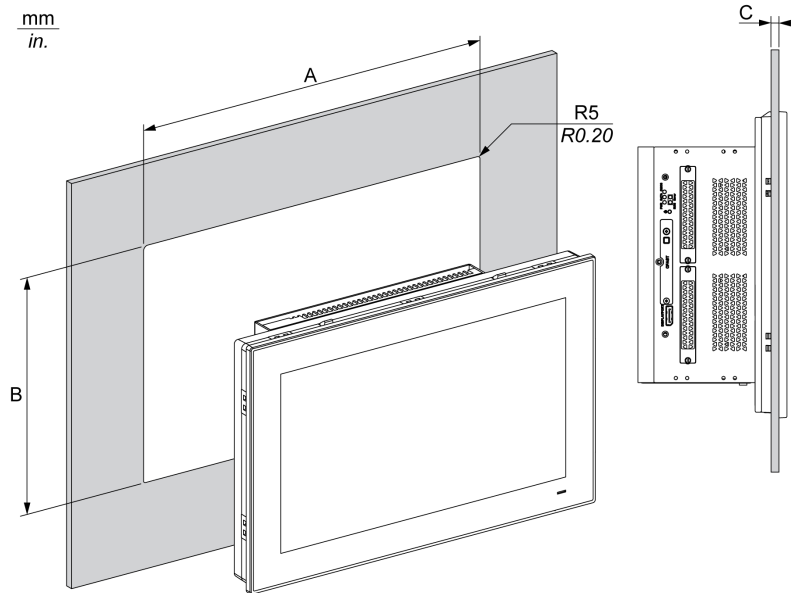

Display Module Cut-out	A	B	C	R
15" single touch	383.5 ±0.7 mm (15.10 ±0.03 in)	282.5 ±0.4 mm (11.12 ±0.02 in)	2...6 mm (0.08...0.24 in)	5 mm (0.20 in)
W15" multi-touch	412.4 ±0.7 mm (16.24 ±0.03 in)	261.7 ±0.4 mm (10.30 ±0.02 in)		
W19" multi-touch	479.3 ±1 mm (18.87 ±0.04 in)	300.3 ±0.7 mm (11.82 ±0.03 in)		
W22" multi-touch	550.3 ±1 mm (21.67 ±0.04 in)	341.8 ±0.7 mm (13.46 ±0.03 in)		

NOTE:

- Ensure that the thickness of the installation panel is from 2 to 6 mm (0.08 to 0.24 in).
- All installation panel surfaces used should be strengthened. Due consideration should be given to the weight of the Display Module, especially if high levels of vibration are expected and the installation panel can move. Attach metal reinforcing strips to the inside of the panel near the panel cut-out to increase the strength of the installation panel.
- Ensure that all installation tolerances are maintained.
- The Display Module is designed for use on a flat surface of a Type 4X enclosure (indoor use only).

Vibration and Shocks

Take extra care with respect to vibration levels when installing or moving the Box. If you move the Box while it is installed in a rack equipped with caster wheels, it may undergo excessive shock and vibration.

CAUTION

EXCESSIVE VIBRATION

- Plan your installation activities so that shock and vibration tolerances in the unit are not exceeded.
- Ensure that the installation panel opening and thickness are within the specified tolerances.
- Before mounting the Box into a cabinet or panel, ensure that the installation gasket is in place. The installation gasket provides additional protection from vibration.
- Tighten the installation fasteners using a torque of 0.5 Nm (4.5 lb-in).

Failure to follow these instructions can result in injury or equipment damage.

Installation Gasket

The gasket is required to meet the protection ratings (IP66 or Type 4X indoor) of the Display Module.

NOTE: IP66 is not part of UL certification.

CAUTION

LOSS OF SEAL

- Inspect the gasket prior to installation or reinstallation, and periodically as required by your operating environment.
- Replace the complete Box if visible scratches, tears, dirt, or excessive wear are noted during inspection.
- Do not stretch the gasket unnecessarily or allow the gasket to contact the corners or edges of the frame.
- Ensure that the gasket is fully seated in the installation groove.
- Install the Box into a panel that is flat and free of scratches or dents.
- Tighten the installation fasteners using a torque of 0.5 Nm (4.5 lb-in).

Failure to follow these instructions can result in injury or equipment damage.

Installation of the Display Module

The installation gasket and the installation fasteners are required for the easy installation of the Display Module. The panel mounting process of the easy installation can be completed by one person.

NOTE: For easy installation, the suggested mounting panel thickness can be up to 2 mm (0.079 in).

Follow these steps for easy installation of the Display Module:

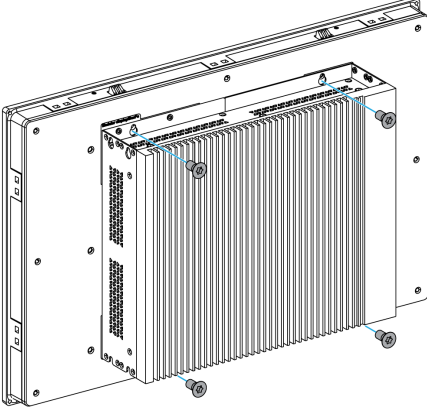
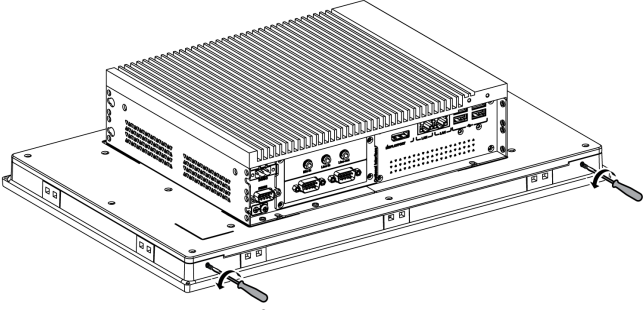
Step	Action
1	Remove all power and confirm that the power supply is disconnected from its power source.
2	Check that the gasket is correctly attached to the Display Module. NOTE: When checking the gasket, avoid contact with the sharp edges of the Display Module frame, and insert the gasket completely into its groove.
3	Fasten the Box on the rear side of the Display Module with four screws: 
4	Release the two screws at the bottom of the Display Module: 

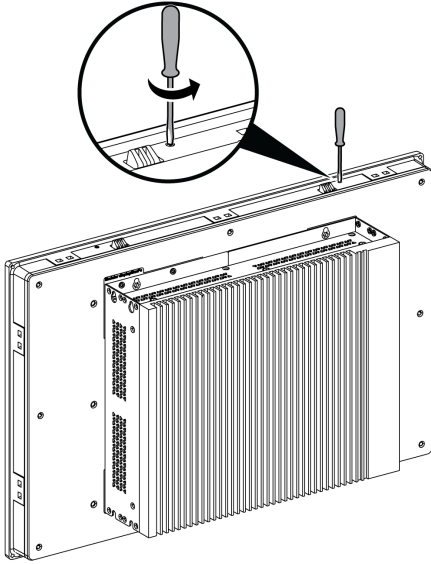
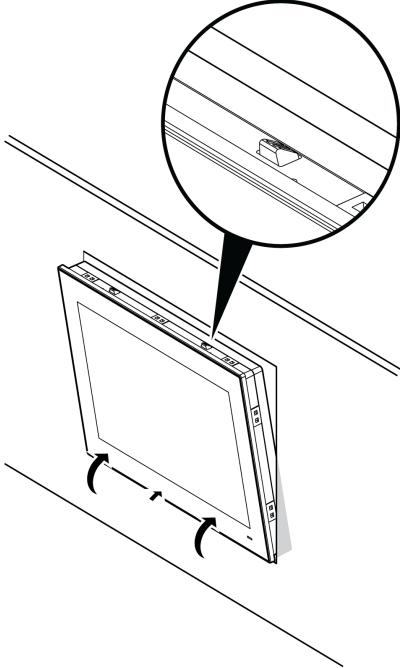
Step	Action
5	<p data-bbox="323 204 1188 227">Loosen the cross-slotted screws from the top of the Display Module to raise the snap hook:</p>  <p data-bbox="323 852 378 875">Note:</p> <ul data-bbox="323 877 916 929" style="list-style-type: none"><li data-bbox="323 877 916 900">● 2 snap hook for the 15" single touch and W15" multi-touch<li data-bbox="323 902 916 929">● 3 snap hook for the W19" multi-touch and W22" multi-touch
6	<p data-bbox="323 944 1243 996">Install the Display Module in the panel opening and push it into the wall. The snap hook holds the Display Module in place:</p> 

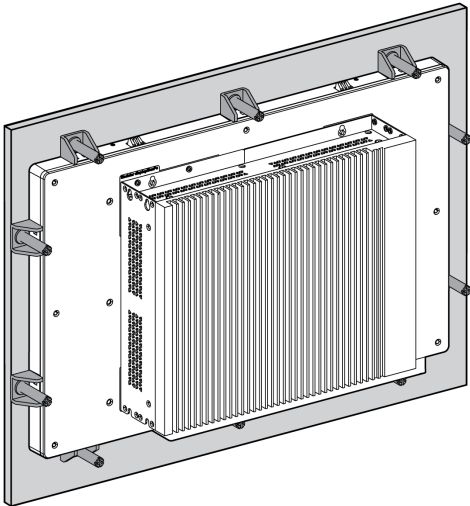
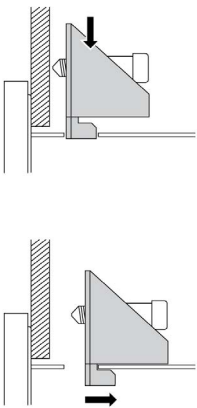
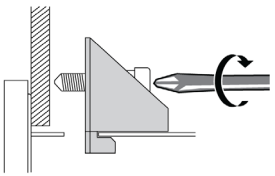
<p>7</p>	<p>Insert the installation fasteners into the slots of the Display Module:</p>  <p>Note:</p> <ul style="list-style-type: none"> ● 10 installation fasteners for the 15" single touch and W15" multi-touch ● 12 installation fasteners for the W19" multi-touch and W22" multi-touch
<p>8</p>	<p>Insert each fastener in its corresponding slot and pull the fastener back until it is flush with the rear of the fastener hole:</p> 
<p>9</p>	<p>Tighten each of the cross-slotted fastener screws, and fasten the Display Module in place:</p>  <p>NOTE: To ensure a high degree of moisture resistance, use a torque of 0.5 Nm (4.5 lb-in).</p>
<p>10</p>	<p>The angle of the Display Module is tilted no more than the amount allowed by the mounting orientation requirements.</p>

⚠ CAUTION

OVERTORQUE AND LOOSE HARDWARE

- Do not exert more than 0.5 Nm (4.5 lb-in) of torque when tightening the installation fastener, enclosure, accessory, or terminal block screws. Tightening the screws with excessive force can damage the installation fastener.
- When fastening or removing screws, ensure they do not fall inside the Box chassis.

Failure to follow these instructions can result in injury or equipment damage.

NOTE: The installation fasteners are required to meet the protection ratings (IP66 or Type 4X indoor) of the Display Module. IP66 is not part of UL certification.

Installation with the VESA

NOTE: The references for the VESA mounting kit for Box 0-Slot is PFXZPBADVS02 and for Box 2-Slot is PFXZPBADVS22

Follow these steps when installing Box with the VESA (video electronics standards association):

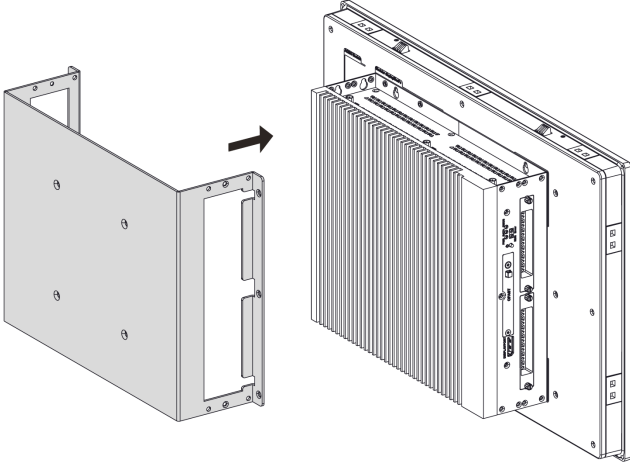
Step	Action
1	Put the VESA mounting kit on the rear side of the Box: 

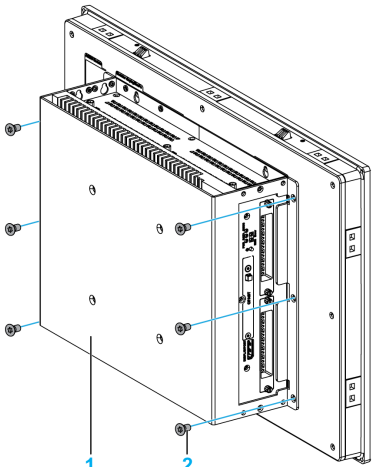
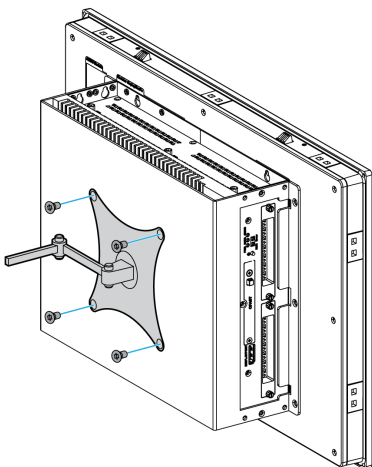
Step	Action
2	<p data-bbox="293 200 1188 227">Fasten the VESA mounting kit on the rear side of the Box with six M4 screws (8 mm (0.31 in)):</p>  <p data-bbox="293 724 871 751">1 VESA plate position (size 100 x 100 mm (3.94 x 3.94 in))</p> <p data-bbox="293 753 706 778">2 6 x VESA mount screws for attachment</p>
3	<p data-bbox="293 788 1215 865">Install your support in the corresponding holes as shown. Fasten the VESA support with four M4 screws (10 mm (0.39 in)) and the angle of the Box is tilted no more than the amount allowed by the mounting orientation requirements:</p>  <p data-bbox="293 1392 1044 1420">NOTE: The recommended torque to tighten these screws is 0.5 Nm (4.5 lb-in).</p>

Display Module and Display Adapter Installation

Spacing Requirements

In order to provide sufficient air circulation, mount the Display Module to have the spacing above, below, and on the sides of the unit (*see page 55*).

Mounting Orientation

The following figure shows the allowed mounting orientation for the Display Module with the Display Adapter:

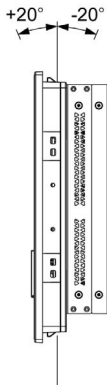

Panel Cut Dimensions

For cabinet installation, you need to cut the correct sized opening in the installation panel according to the model of Display Module (*see page 56*).

Installation Gasket

The gasket is required to meet the protection ratings (IP66 or Type 4X indoor) of the Display Module.

NOTE: IP66 is not part of UL certification.

⚠ CAUTION

LOSS OF SEAL

- Inspect the gasket prior to installation or reinstallation, and periodically as required by your operating environment.
- Replace the complete Box if visible scratches, tears, dirt, or excessive wear are noted during inspection.
- Do not stretch the gasket unnecessarily or allow the gasket to contact the corners or edges of the frame.
- Ensure that the gasket is fully seated in the installation groove.
- Install the Box into a panel that is flat and free of scratches or dents.
- Tighten the installation fasteners using a torque of 0.5 Nm (4.5 lb-in).

Failure to follow these instructions can result in injury or equipment damage.

Installation of the Display Module

The installation gasket and the installation fasteners are required for the easy installation of the Display Module. The panel mounting process of the easy installation can be completed by one person.

NOTE: For easy installation, the suggested mounting panel thickness can be up to 2 mm (0.079 in).

Follow these steps for installation of the Display Module with the Display Adapter:

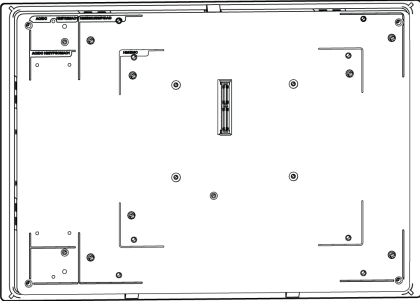
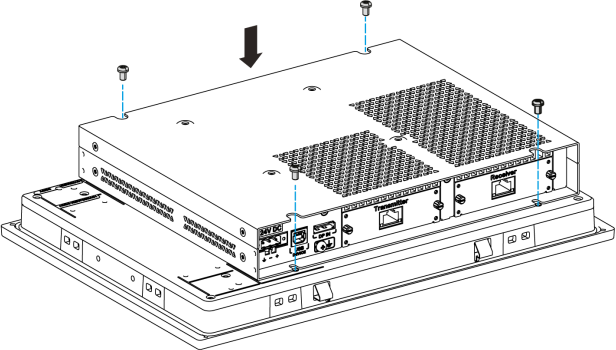
Step	Action
1	Remove all power and confirm that the power supply is disconnected from its power source.
2	Check that the gasket is correctly attached to the Display Module. NOTE: When checking the gasket, avoid contact with the sharp edges of the Display Module frame, and insert the gasket completely into its groove.
3	Fasten the Display Adapter on the rear side of the Display Module with four screws: 
4	Fasten the Display Adapter on the rear side of the Display Module with four M4 screws: 

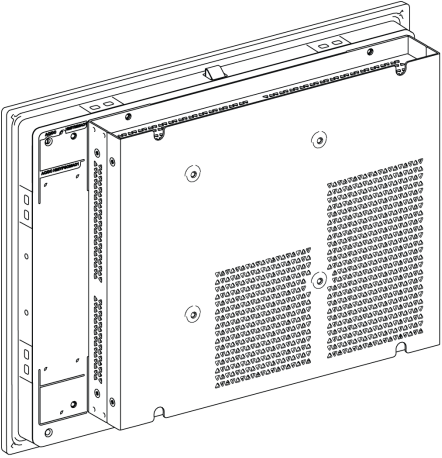
Step	Action
5	<p>Install the Display Module in the panel opening, refer to Installation of the Display Module. (see page 58)</p> 
6	<p>The angle of the Display Module is tilted no more than the amount allowed by the mounting orientation requirements.</p>

⚠ CAUTION

OVERTORQUE AND LOOSE HARDWARE

- Do not exert more than 0.5 Nm (4.5 lb-in) of torque when tightening the installation fastener, enclosure, accessory, or terminal block screws. Tightening the screws with excessive force can damage the installation fastener.
- When fastening or removing screws, ensure they do not fall inside the Box chassis.

Failure to follow these instructions can result in injury or equipment damage.

Installation of the Receiver and the Transmitter on Display Adapter (pending)

Follow these steps for installation of the Receiver and the Transmitter:

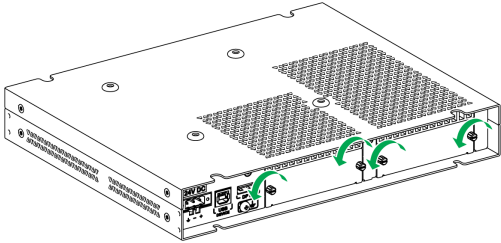
Step	Action
1	<p>Unscrew the Transmitter and Receiver panel covers from the Display Adapter:</p> 

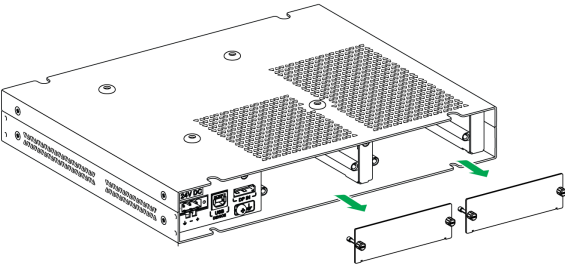
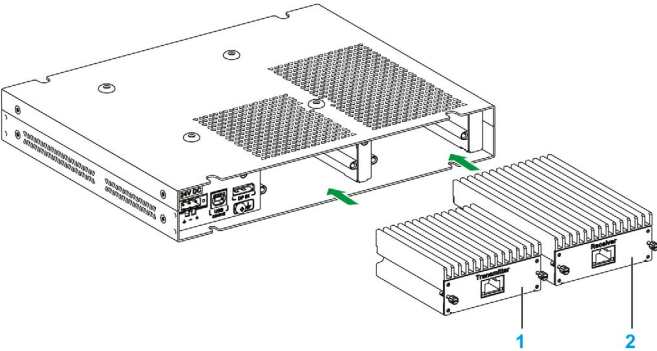
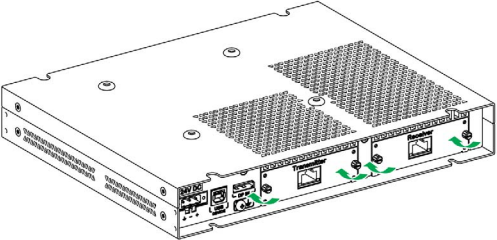
Step	Action
2	<p>Pull the Transmitter (PFXZPPDMPTX2) and Receiver (PFXZPPDMPRX2) panel covers from the Display Adapter:</p> 
3	<p>Insert the Transmitter and Receiver in the respective slots in the Display Adapter.</p>  <p>1 Transmitter 2 Receiver</p>
4	<p>Fasten the covers with screws.</p> 
5	<p>Install the Display Adapter on the Display Module, refer to Installation of the Display Module. (see page 64)</p>

⚠ CAUTION

OVERTORQUE AND LOOSE HARDWARE

- Do not exert more than 0.5 Nm (4.5 lb-in) of torque when tightening the installation fastener, enclosure, accessory, or terminal block screws. Tightening the screws with excessive force can damage the installation fastener.
- When fastening or removing screws, ensure they do not fall inside the Box chassis.

Failure to follow these instructions can result in injury or equipment damage.

Installation with the VESA

Follow these steps when installing Display Adapter with the VESA:

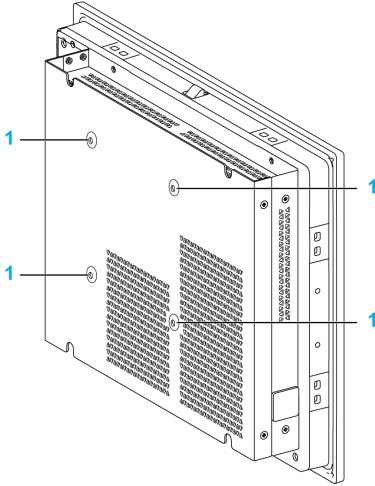
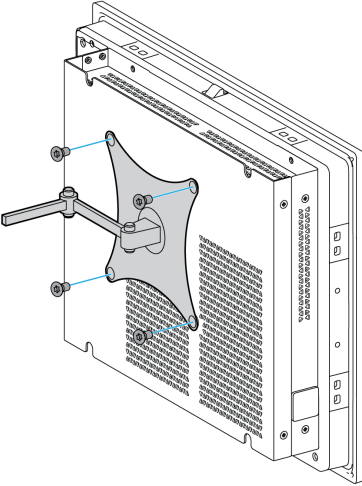
Step	Action
1	<p>There are four VESA holes on the rear side of the Display Adapter:</p>  <p>1 VESA holes (size 100 x 100 mm (3.94 x 3.94 in))</p>
2	<p>Install your support in the corresponding holes as shown. Fasten the VESA support with four M4 screws (10 mm (0.39 in)) and the angle of the Box is tilted no more than the amount allowed by the mounting orientation requirements:</p>  <p>NOTE: The recommended torque to tighten these screws is 0.5 Nm (4.5 lb-in).</p>

Chapter 6

Getting Started

First Power up

License Agreement

Limitations on your usage of the Microsoft Windows Operating System are noted in Microsoft's End User License Agreement (EULA). This EULA is included on the recovery media containing the software required to reinstall the operating system. Read this document before the first power-up.

To customize and set the system parameters during the first power-up of your Box, refer to the Box Installation guide.

Windows Embedded (WES)

The WES is a modularized version of the Windows operating system that provides increased reliability and customizations. It offers the power and familiarity of Windows in a compact, more reliable form. For more information, refer to Microsoft Windows Embedded Web page.

WES provides many tools for the customization of menus, boot screens, and dialog boxes. With WES, you can remove the Windows boot and resume animations so the screen remains black during startup. You can also remove the Windows logo from the login screen and other startup screens. Other common features of Windows include the message and dialog boxes. WES can filter these messages and keep them from appearing during run time. The developer can choose to hide any dialog box and predefine its default operation so it never displays to the user.

EFW Manager (only on WES7)

The Box operating system is installed on a memory card. This card is a rewritable CFast card that enables approximately 100,000 write operations.

The EWF manager (enhanced write filter manager) minimizes the number of write operations to help extend the life of the CFast card. The EWF manager loads temporary data (for example, system updates and software operations) into RAM, and does not write this information to the CFast card.

As a result, when using the EWF manager, restarting the Box overwrites changes that the user has made to the system. The following types of changes may be overwritten if the EWF manager is active and the system is restarted:

- Newly installed applications.
- Newly installed peripherals.
- Newly created or modified user accounts.
- Network configuration changes (such as IP addresses or default gateways).
- Operating System customizations (such as desktop background).

NOTICE

DATA AND CONFIGURATION LOSS

- Disable the EWF Manager before making any permanent changes to the hardware, software, or Operating System of the Box.
- Re-enable the EWF Manager after making permanent changes. This helps extend the operating life of the memory card.
- Back up all memory card data regularly to another storage media.

Failure to follow these instructions can result in equipment damage.

NOTE: Use Microsoft Embedded Lockdown Manager when using Windows Embedded 8.1 Industry 64 bits MUI.

Enabling/Disabling the EWF Manager

You can change the status of the EWF Manager by running the `EWFManager.exe` program located in `C:\Program Files\EWFManager\`. After running this program, restart the system for the change to take effect. You need administrator privileges to enable and disable the EWF Manager.

Right Click from Touch Screen Interface

To access the **right-click** function from the touch screen, keep touching the screen for 2 seconds and the corresponding **right-click** function is activated (for instance, displaying the shortcut menu).

HORM

In HORM (hibernate once resume many) environment, a single hibernation file is used to restart the system repeatedly. To set a HORM environment, follow the steps below.

Make sure that EWF is disabled. You can run **OSUnLock** to disable EWF.

Enable hibernation support: From the **Control Panel**, run **Power Options** and then select **Enable Hibernation** in **Hibernation** panel.

Enable **EWF** by running **OSLock**. The system restarts.

Open the software that customers want to use right after the system resumes from hibernation.

Hibernate using the **HORM** tool. Click **Start Menu** → **All Programs** → **EWF**

The system continues to use the HORM environment unless you disable HORM. To disable **HORM**, run the **EWF** commit command (`ewfmgr c: -commit`) and then restart the system. When the system starts up, enter **F8** and select **Discard hibernation file**.

NOTE: This feature is not supported by a CFast 16 GB.

Metro Interface with Windows Embedded 8.1 Industry

The windows **Metro** (built-in apps) is disabled by default because the UAC (user account control) notification is set to `Never notify`. For all software applications, we recommend to use the desktop version or change the software setting to start in desktop mode. Example: use **Internet Explorer** browser in desktop mode.

Chapter 7

Connections

Subject of This Chapter

This chapter describes the connection of the Box to the main power supply. It also describes the USB ports and identifies the serial interface pin assignments.

What Is in This Chapter?

This chapter contains the following topics:

Topic	Page
Grounding	72
Connecting the DC Power Cord	76
AC Power Supply Module Description and Installation	79
UPS Module - Description and Installation	90
Box Interface Connections	98

Grounding

Overview

The grounding resistance between the Box ground wire and the ground must be 100 Ω or less. When using a long grounding wire, check the resistance and, if required, replace the wire with a thicker wire and place it in a duct.

The table shows the maximum length for the wires:

Wire cross-section	Maximum line length
2.5 mm ² (AWG 14)	30 m (98 ft)
	60 m (196 ft) round trip

Grounding Procedure

⚠ WARNING

UNINTENDED EQUIPMENT OPERATION

- Use only the authorized grounding configurations shown below.
- Confirm that the grounding resistance is 100 Ω or less.
- Test the quality of your ground connection before applying power to the device. Excess noise on the ground line can disrupt operations of the Box.

Failure to follow these instructions can result in death, serious injury, or equipment damage.

The Box and the Display Adapter ground have 2 connections:

- DC Supply voltage
- Ground connection pin

The Box connections:

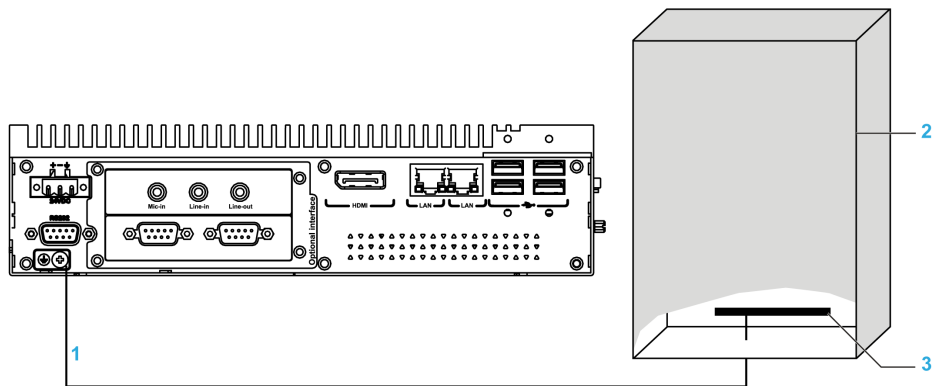

- 1 Ground connection pin (functional ground connection pin)
- 2 Switching cabinet
- 3 Grounding strip

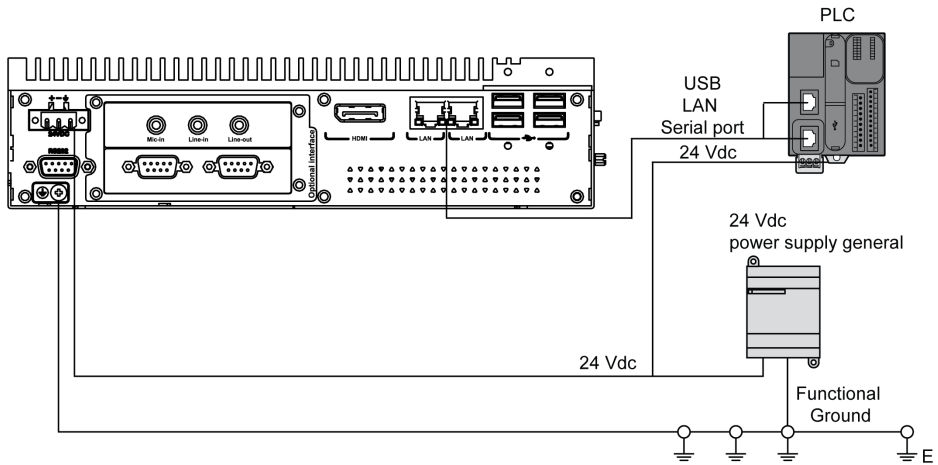

The Display Adapter connections:

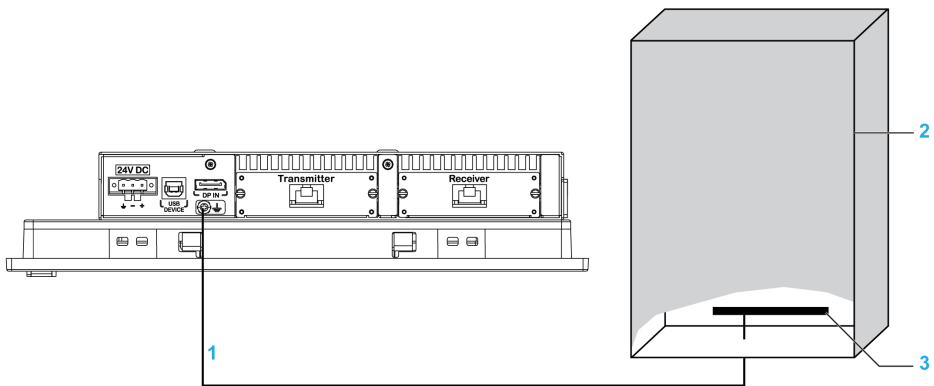

- 1 Ground connection pin (functional ground connection pin)
- 2 Switching cabinet
- 3 Grounding strip

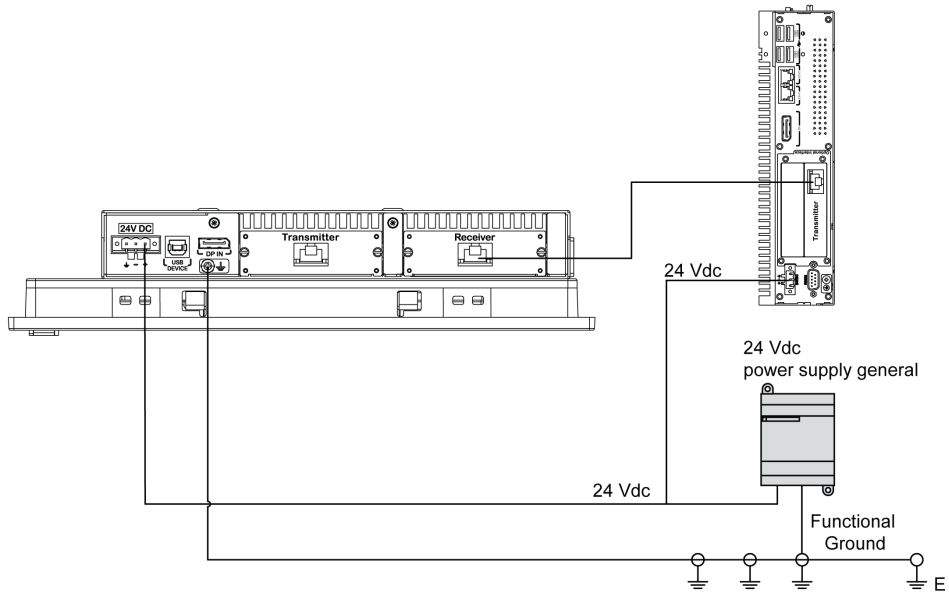

When grounding, follow this procedure:

Step	Action
1	<p>Ensure all of the following is done for the system wiring:</p> <ul style="list-style-type: none"> ● Connect the cabinet to ground. ● Ensure that all cabinets are grounded together. ● Connect the ground of the power supply to the cabinet. ● Connect the ground pin of the Box to the cabinet. ● Connect the I/O to the controller if needed. ● Connect the power supply to the Box.
2	Check that the grounding resistance is 100 Ω or less.
3	<p>When connecting the SG line to another device, ensure that the design of the system/connection does not produce a ground loop.</p> <p>NOTE: The SG and ground connection screw are connected internally in the Box.</p>
4	Use 2.5 mm ² (AWG 14) wire to make the ground connection. Create the connection point as close to the Box as possible and make the wire as short as possible.

Grounding I/O Signal Lines

The Boxes PFXPP2B, PFXPU2B, PFXPP27, PFXPP2J, PFXPU27, PFXPU2J, and the Display Adapter PFXZPPDADDP2 are classified hazardous locations Class I Division 2 (see chapter "Certifications and Standards"). Observe the following:

 DANGER
<p>POTENTIAL FOR EXPLOSION</p> <ul style="list-style-type: none"> ● Always confirm the ANSI/ISA 12.12.01 and CSA C22.2 N°213 hazardous location rating of your device before installing or using it in a hazardous location. ● To power on or power off a Box installed in a Class I, Division 2 hazardous location, you must either: <ul style="list-style-type: none"> ○ Use a switch located outside the hazardous environment, or ○ Use a switch certified for Class I, Division 1 operation inside the hazardous area. ● Do not connect or disconnect equipment unless power has been switched off or the area is known to be non-hazardous. This applies to all connections including power, ground, serial, parallel, network, and rear USB connections. ● Never use unshielded / ungrounded cables in hazardous locations. ● When enclosed, keep enclosure doors and openings closed at all times to avoid the accumulation of foreign matter inside the workstation. ● Do not use front USB and keep the cover in place. ● Do not expose to direct sunlight or UV light source. <p>Failure to follow these instructions will result in death or serious injury.</p>

NOTE: When using a Display Module PFXPPD5700TA or a Display Module PFXPPD5700WP with the Box Celeron and Box Core i7 (classified hazardous locations) can be classified hazardous locations.

NOTE: When using DC power supply, Display Adapter (PFXZPPDADDP2) with the Display Module can be classified hazardous locations. When using AC power supply, the Display Adapter with the Display Module and the AC power supply adapter for 100 W (PFXZPBPUAC2) can be classified hazardous location.

The Box PFXPP2L, PFXPP2N, PFXPU2L, PFXPU2N and the Display Module PFXPPD5800WP, PFXPPD5900WP are not classified hazardous locations.

 DANGER
<p>POTENTIAL FOR EXPLOSION IN HAZARDOUS LOCATION</p> <p>Do not use this product in hazardous locations.</p> <p>Failure to follow these instructions will result in death or serious injury.</p>

Electromagnetic radiation may interfere with the control communications of the Box.

 WARNING
<p>UNINTENDED EQUIPMENT OPERATION</p> <ul style="list-style-type: none"> ● If wiring of I/O lines near power lines or radio equipment is unavoidable, use shielded cables and ground one end of the shield to the Box ground connection screw. ● Do not wire I/O lines in proximity to power cables, radio devices, or other equipment that may cause electromagnetic interference. <p>Failure to follow these instructions can result in death, serious injury, or equipment damage.</p>

Connecting the DC Power Cord

Precaution

When connecting the power cord to the power connector on the Box, first ensure that the power cord is disconnected from the DC power supply.

⚠ ⚠ DANGER

HAZARD OF ELECTRIC SHOCK, EXPLOSION OR ARC FLASH

- Remove all power from the device before removing any covers or elements of the system, and prior to installing or removing any accessories, hardware, or cables.
- Unplug the power cable from both the Box and the power supply.
- Always use a properly rated voltage sensing device to confirm power is off.
- Replace and secure all covers or elements of the system before applying power to the unit.
- Use only the specified voltage when operating the Box. The DC unit is designed to use 24 Vdc input.

Failure to follow these instructions will result in death or serious injury.

⚠ WARNING

EQUIPMENT DISCONNECTION OR UNINTENDED EQUIPMENT OPERATION

- Ensure that power, communication, and accessory connections do not place excessive stress on the ports. Consider the vibration in the environment.
- Securely attach power, communication, and external accessory cables to the panel or cabinet.
- Use only D-Sub 9-pin connector cables with a locking system in good condition.
- Use only commercially available USB cables.

Failure to follow these instructions can result in death, serious injury, or equipment damage.

Wiring and Connecting the Terminal Block of the Box

The table below describes how to connect the power cord to the DC terminal block:

Step	Action
1	Remove all power from the Box and confirm that the DC power supply is disconnected from its power source.
2	<p>Remove the terminal block (PFXZPBCNDC2) from the power connector on the Box and connect the power cord to the terminal block:</p> <div style="text-align: center;"> </div> <p>Use copper wire rated for 75 °C (167 °F) with a section of 0.75 to 2.5 mm² (AWG 18 to AWG 14) and use 2.5 mm² wire to make the ground connection.</p>

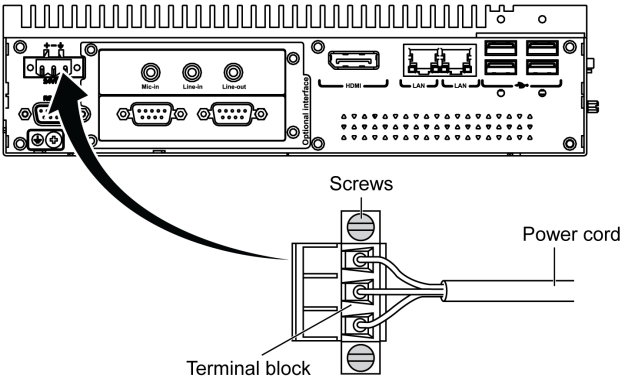
Step	Action
3	<p>Place the terminal block in the power connector and tighten the screws:</p>  <p>NOTE: The recommended torque to tighten these screws is 0.5 Nm (4.5 lb-in).</p>

Wiring and Connecting the Terminal Block of the Display Adapter

The table below describes how to connect the power cord to the DC terminal block:

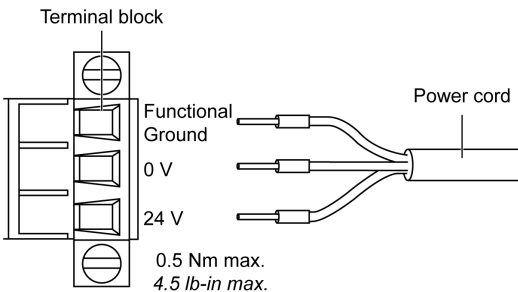
Step	Action
1	Remove all power from the Display Adapter and confirm that the DC power supply is disconnected from its power source.
2	<p>Remove the terminal block (PFXZPBCNDC2) from the power connector on the Display Adapter and connect the power cord to the terminal block:</p>  <p>Use copper wire rated for 75 °C (167 °F) with a section of 0.75 to 2.5 mm² (AWG 18 to AWG 14) and use 2.5 mm² wire to make the ground connection.</p>

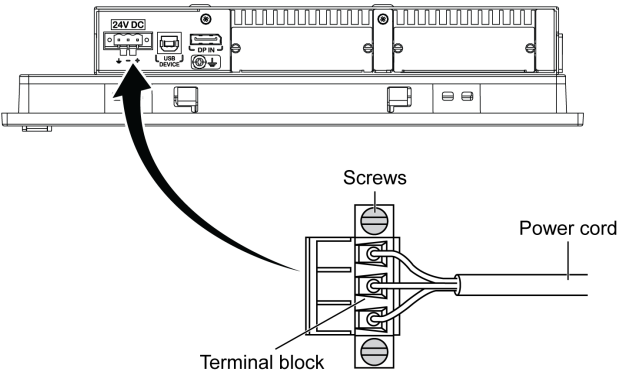
Step	Action
3	<p data-bbox="321 200 998 227">Place the terminal block in the power connector and tighten the screws:</p>  <p data-bbox="321 668 1071 695">NOTE: The recommended torque to tighten these screws is 0.5 Nm (4.5 lb-in).</p>

AC Power Supply Module Description and Installation

Overview

The AC power supply module (PFXZPBUAC2) can optionally be mounted on the Box or Display Adapter (PFXZPPDADDP2) to be operated with 100...240 Vac.

If there is not a classified hazardous location, the AC power supply module (PFXZPSUAC2) can optionally be mounted on the Display Adapter (PFXZPPDADDP2) to be operated with 100...240 Vac.

The table shows the AC power supplies associate with the Box or Display Adapter (PFXZPPDADDP2):

AC power supply	PFXPU/PFXPP	PFXPE (pending)	Display Adapter	Hazardous location
PFXZPSUAC2 (60 W)	–	X	X	–
PFXZPBUAC2 (100 W)	X	X	X	X

AC Power Supply Module (PFXZPBUAC2) Description

The figure shows the AC power supply module:

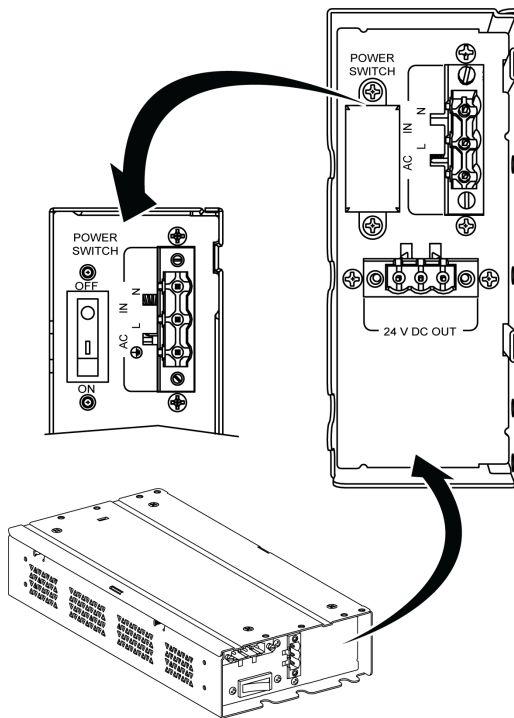

The figure shows the DC power cable of the AC power supply module:

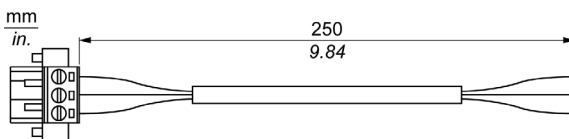

The figure shows the dimensions of the AC power supply module:

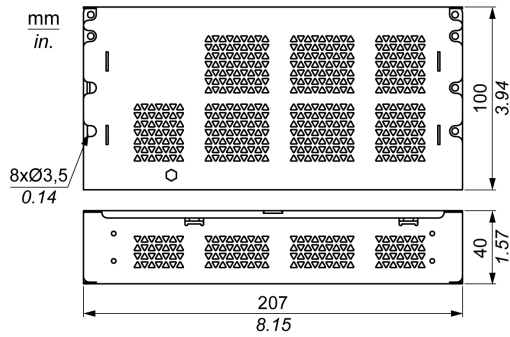

The table gives the technical data of the AC power supply module:

Features	Values
Nominal input voltage	100...240 Vac
Frequency	47...63 Hz
Power switch	Yes
Internal fuse	3.15 A
Nominal output voltage	24 Vdc
Output current	4.6 A maximum
Operation temperature	0...50 °C (32...122 °F)
Weight	0.8 kg (1.76 lb)

AC Power Supply Module (PFXZPSPUAC2) Description

This figure shows the AC power supply module:

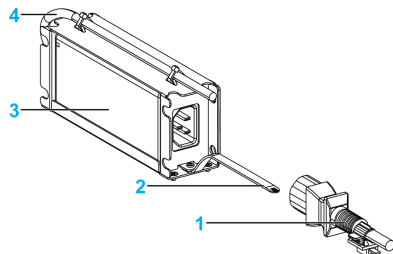

- 1 AC power cord
- 2 Mounting bracket
- 3 AC power supply
- 4 DC power cord

The table provides technical data for the AC power supply module:

Element	Characteristics
Input	90...260 Vac / 47...63 Hz / 1.6 A at 100 Vac
Output	24 Vdc / 2.62 A maximum
Inrush current	70 A at 230 Vac
Environment	
Operation temperature	0...70 °C (32...158 °F), see derating curve
Storage temperature	-40...85 °C (-40...185 °F)
Relative humidity:	0...95 %, non-condensing

Operation temperature of the AC power supply derating curve:

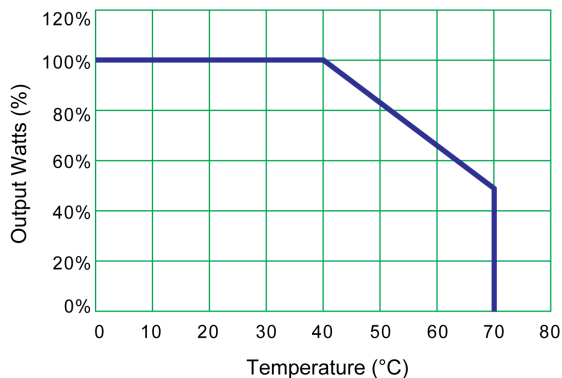

Installing the AC Power Supply Module (PFXZPBUAC2) with The Box

Before installing an AC power supply module (PFXZPBUAC2), shut down Windows operating system in an orderly fashion and remove all power from the device.

DANGER

HAZARD OF ELECTRIC SHOCK, EXPLOSION OR ARC FLASH

- Remove all power from the device before removing any covers or elements of the system, and prior to installing or removing any accessories, hardware, or cables.
- Unplug the power cable from both the Box and the power supply.
- Always use a properly rated voltage sensing device to confirm power is off.
- Replace and secure all covers or elements of the system before applying power to the unit.
- Use only the specified voltage when operating the Box. The AC unit is designed to use 100...240 Vac input.

Failure to follow these instructions will result in death or serious injury.

Follow these steps when installing the AC power supply module (PFXZPBUAC2):

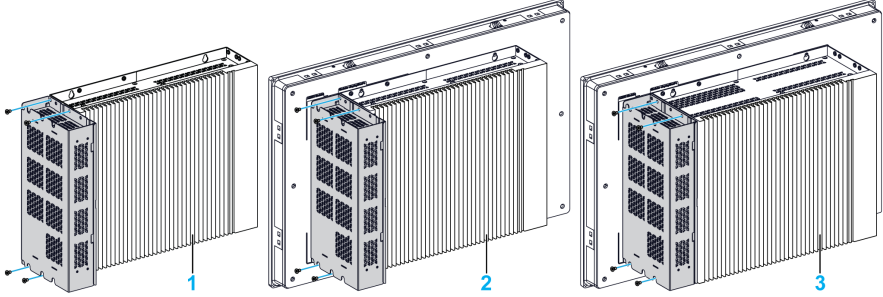
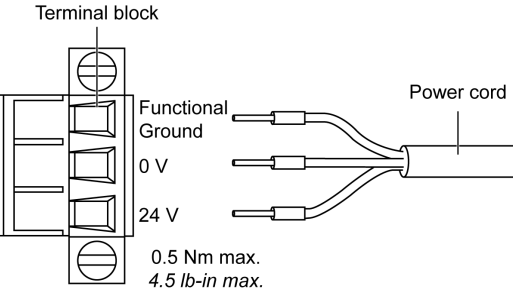
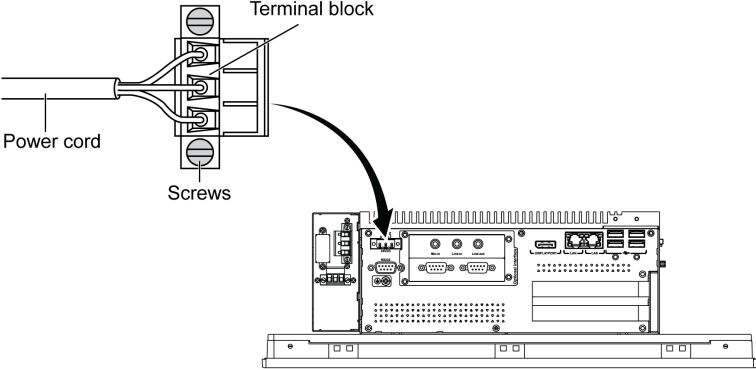
Step	Action
1	Remove all power from the Box and confirm that the power adapter has been disconnected from its power source.
2	<p>Mount the AC power supply module on the Box with four screws (the power switch cover and the AC IN connector have to be removed):</p>  <p>1 Box 0-Slot 2 Box 0-Slot with Display Module 3 Box 2-Slot with Display Module</p> <p>NOTE: The Box can also be mounted in the control cabinet, see Box installation (<i>see page 55</i>).</p>
3	<p>Remove the terminal block (PFXZPBCNDC2) from the power connector on the Box and connect one side of the DC power cable to the terminal block:</p>  <p>Terminal block</p> <p>Functional Ground 0 V 24 V</p> <p>Power cord</p> <p>0.5 Nm max. 4.5 lb-in max.</p>
4	<p>Place the terminal block in the power connector of the Box and tighten the screws:</p>  <p>Terminal block</p> <p>Power cord</p> <p>Screws</p> <p>NOTE: The recommended torque to tighten these screws is 0.5 Nm (4.5 lb-in).</p>

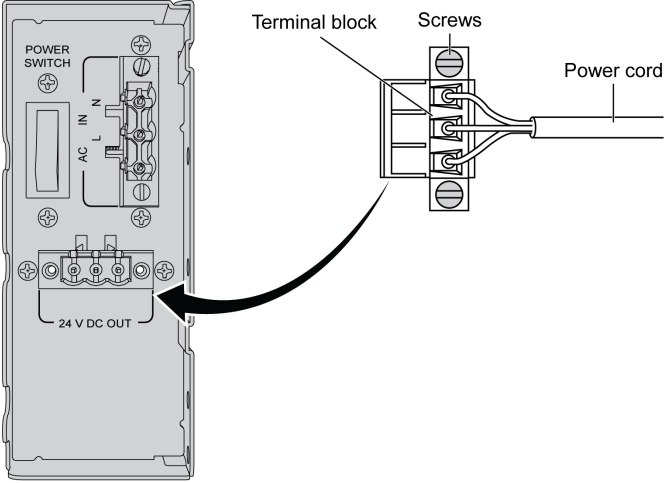
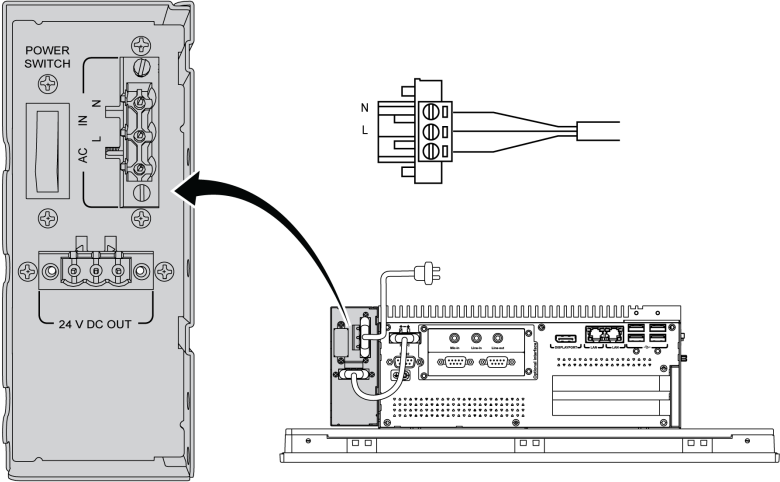
Step	Action
5	<p>Connect the other side of DC power cable with the terminal block (PFXZPBCNDC2) attached to 24 V DC OUT of the AC power supply module and tighten the screw:</p>  <p>Use copper wire rated for 75 °C (167 °F) with a section of 0.75 to 2.5 mm² (AWG 18 to AWG 14).</p>
6	<p>Connect the AC power cable with the terminal block (PFXZPBCNAC2) attached to AC IN of the AC power supply module from its power source:</p> 

⚠ CAUTION

OVERTORQUE AND LOOSE HARDWARE

- Do not exert more than 0.5 Nm (4.5 lb-in) of torque when tightening the installation fastener, enclosure, accessory, or terminal block screws. Tightening the screws with excessive force can damage the installation fastener.
- When fastening or removing screws, ensure they do not fall inside the Box chassis.

Failure to follow these instructions can result in injury or equipment damage.

Installing the AC Power Supply Module (PFXZPBUAC2) with the Display Adapter (PFXZPPDADDP2)

Before installing an AC power supply module (PFXZPBUAC2), shut down Windows operating system in an orderly fashion and remove all power from the device.

⚡ ⚠ **DANGER**

HAZARD OF ELECTRIC SHOCK, EXPLOSION OR ARC FLASH

- Remove all power from the device before removing any covers or elements of the system, and prior to installing or removing any accessories, hardware, or cables.
- Unplug the power cable from both the Box and the power supply.
- Always use a properly rated voltage sensing device to confirm power is off.
- Replace and secure all covers or elements of the system before applying power to the unit.
- Use only the specified voltage when operating the Box. The AC unit is designed to use 100...240 Vac input.

Failure to follow these instructions will result in death or serious injury.

Follow these steps when installing the AC power supply module (PFXZPBUAC2):

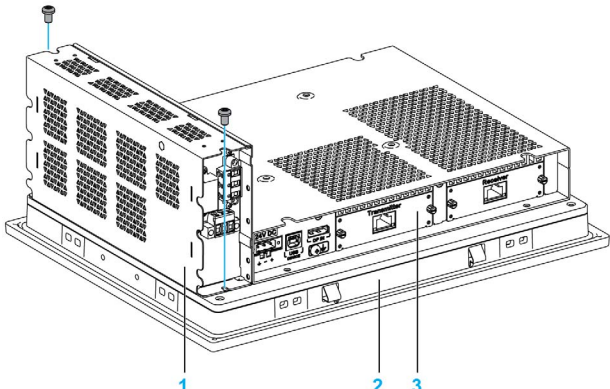
Step	Action
1	Remove all power from the Display Adapter and confirm that the power adapter has been disconnected from its power source.
2	<p>Mount the AC power supply module on the Display Module with two screws M3 x 6 (the power switch cover and the AC IN connector have to be removed):</p>  <p>1 AC power supply module 2 Display Module 3 Display Adapter</p> <p>NOTE: The recommended torque to tighten these screws is 0.5 Nm (4.5 lb-in).</p>

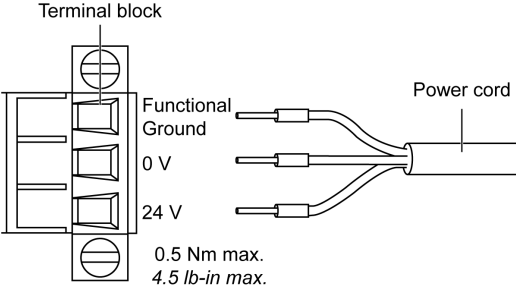
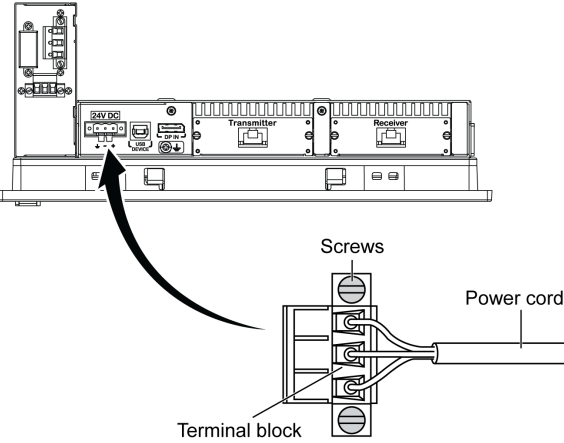
Step	Action
3	<p>Remove the terminal block from the power connector of the Display Adapter and connect the DC power cable to the terminal block:</p>  <p>Use copper wire rated for 75 °C (167 °F) with a section of 0.75 to 2.5 mm² (AWG 18 to AWG 14) and use 2.5 mm² wire to make the ground connection.</p>
4	<p>Place the terminal block in the power connector of the Display Adapter and tighten the screws:</p>  <p>NOTE: The recommended torque to tighten these screws is 0.5 Nm (4.5 lb-in).</p>

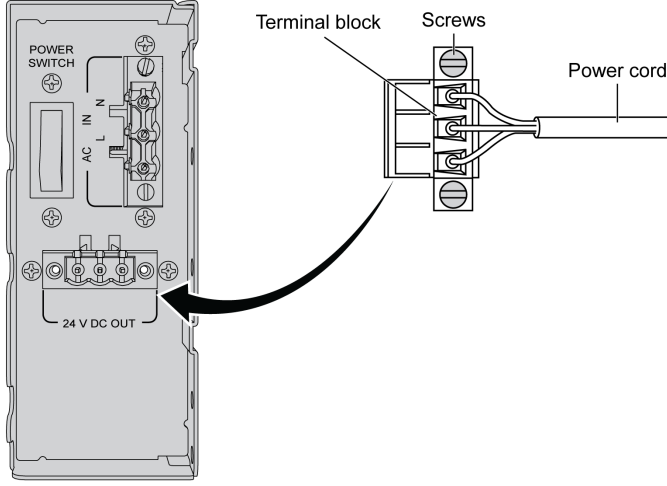
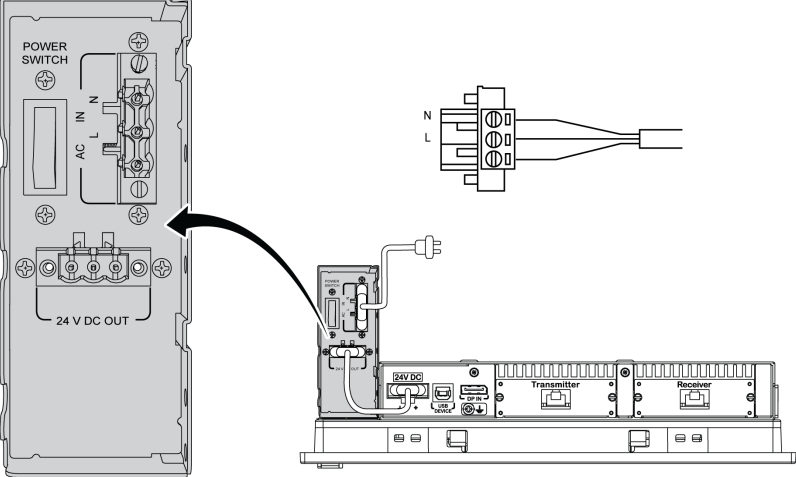
Step	Action
5	<p>Connect the other side of DC power cable with the terminal block (PFXZPBCNDC2) attached to 24 V DC OUT of the AC power supply module and tighten the screw:</p>  <p>Use copper wire rated for 75 °C (167 °F) with a section of 0.75 to 2.5 mm² (AWG 18 to AWG 14).</p>
6	<p>Connect the AC power cable with the terminal block (PFXZPBCNAC2) attached to AC IN of the AC power supply module from its power source:</p> 
7	<p>The Display Module can now be mounted back in the control cabinet, see Display Module installation (<i>see page 55</i>).</p>

⚠ CAUTION

OVERTORQUE AND LOOSE HARDWARE

- Do not exert more than 0.5 Nm (4.5 lb-in) of torque when tightening the installation fastener, enclosure, accessory, or terminal block screws. Tightening the screws with excessive force can damage the installation fastener.
- When fastening or removing screws, ensure they do not fall inside the Box chassis.

Failure to follow these instructions can result in injury or equipment damage.

Installing the AC Power Supply Module (PFXZSPUAC2) with the Display Adapter (PFXZPPDADDP2)

The table provides how to connect the AC power supply module (PFXZSPUAC2):

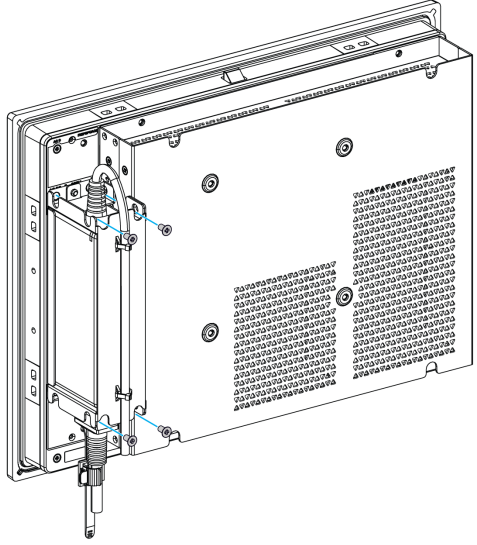
Step	Action
1	Remove all power from the Display Adapter and confirm that the power adapter is disconnected from its power source.
2	The AC power supply module is mounted to the Display Adapter with four screws M3 x 6:  <p>NOTE: The recommended torque to tighten these screws is 0.5 Nm (4.5 lb-in).</p>

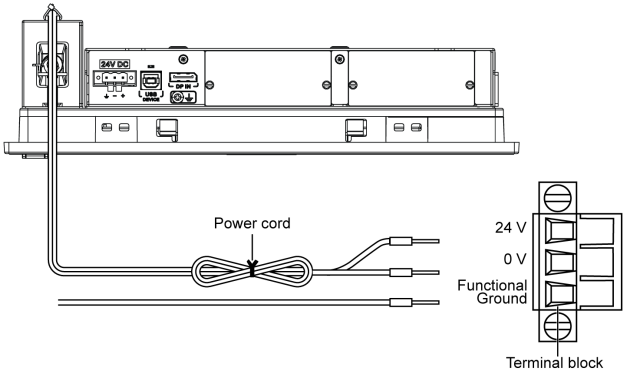
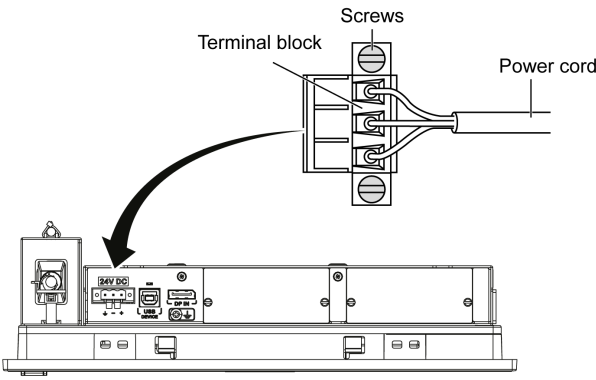
Step	Action
3	<p>Remove the terminal block from the power connector and connect the power cord to the terminal block:</p>  <p>Connect the black wire with the 0 V and the red wire with the 24 V of the terminal block. Use 2.5 mm² copper wire to make the ground connection of the terminal block.</p>
4	<p>Place the terminal block in the power connector and tighten the screws:</p>  <p>NOTE: The recommended torque to tighten these screws is 0.5 Nm (4.5 lb-in).</p>

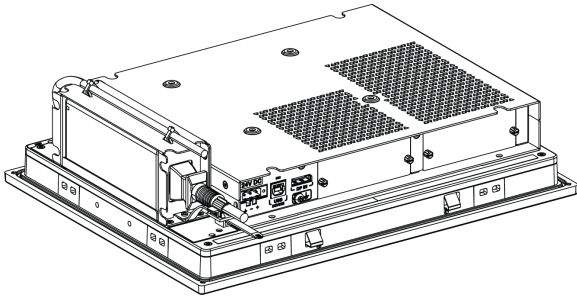
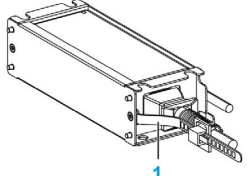
Step	Action
5	<p data-bbox="353 202 1053 227">Put on the clip through the mounting bracket and the power cord together:</p>  <p data-bbox="353 589 724 614">Press the clip to fasten the power cord:</p>  <p data-bbox="353 821 559 846">1 Mounting bracket</p>
6	Connect the AC power cable of the AC power supply module from its power source

⚠ CAUTION

OVERTORQUE AND LOOSE HARDWARE

- Do not exert more than 0.5 Nm (4.5 lb-in) of torque when tightening the installation fastener, enclosure, accessory, or terminal block screws. Tightening the screws with excessive force can damage the installation fastener.
- When fastening or removing screws, ensure they do not fall inside the Box chassis.

Failure to follow these instructions can result in injury or equipment damage.

UPS Module - Description and Installation

Overview

⚠ DANGER

EXPLOSION, FIRE, OR CHEMICAL HAZARD

Handling and storage:

- Store in cool, dry and well ventilated rooms with impermeable surfaces and appropriate containment in case of leakage.
- Protect from adverse weather conditions and keep separate from incompatible materials during storage and transport.
- A sufficient supply of water must be located nearby.
- Damage to containers where batteries are stored and transported must be prevented.
- Keep away from fire, sparks, and excessive heat.

Failure to follow these instructions will result in death or serious injury.

The uninterrupted power supply (UPS) option (PFXZPBUEUUPB2) includes battery cell, charger circuit, and power path switch circuit. When battery capacity is not full, the charger circuit charges battery cell automatically.

The figure shows the UPS module:

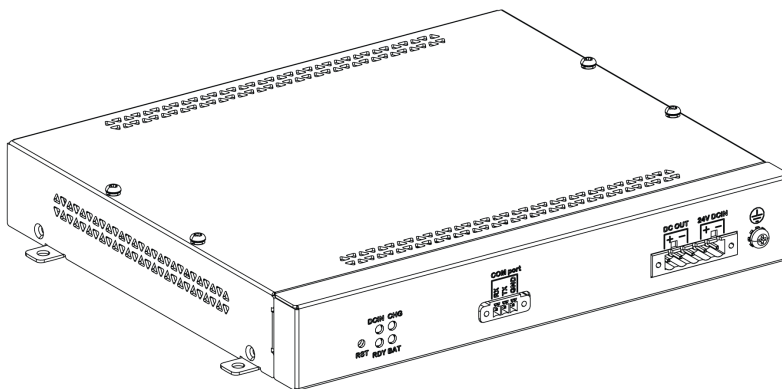

The figure shows the cables of the UPS module:

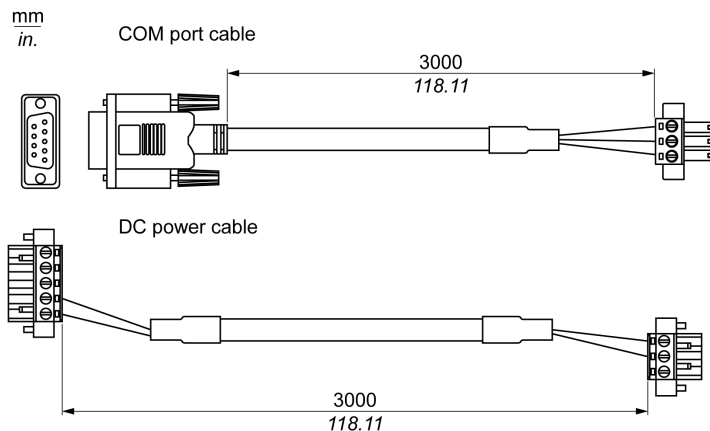

The main features of the UPS option are:

- Long-lasting, maintenance-free rechargeable batteries
- Communication via integrated interfaces

UPS Principle

With the optional UPS module, the Box completes write operations even when it is turned off while write operations are being executed. When the UPS module detects a power off, it switches to battery operation immediately without interruption.

NOTE:

- This function is only available if the UPS is configured and the UPS driver is activated.
- The monitor connected is not handled by the UPS and shut-off when the power is exhausted.
- Only use COM1 of the Box to connect to UPS module.

There are two configurations for UPS module:

- UPS module: The power source of the UPS module is from DC input power.
- UPS and AC power supply modules: The power source of the module is from AC input power.

The figure shows the UPS module (PFXZPBEUUPB2) with the AC power supply module (PFXZPBPUAC2) and the Box with the Com port cable and the DC power cable of the UPS cable kit (PFXZPBCBUP32):

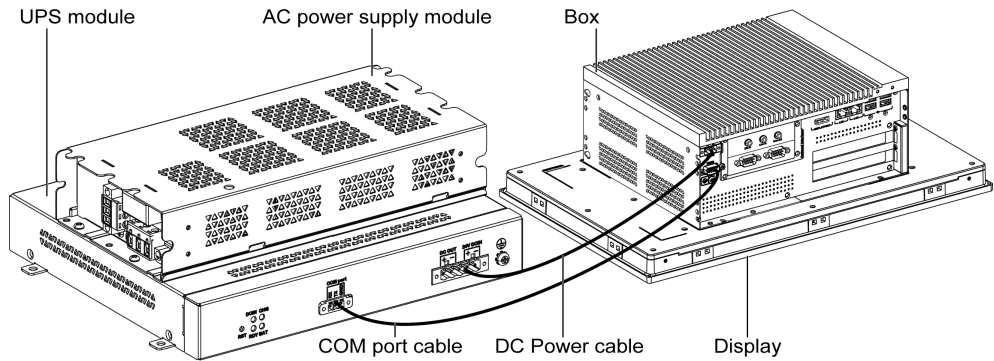

NOTE: The Box can get battery information from COM port. Only COM1 can be used to detect UPS module information. The communication module of the optional interface cannot use for UPS module; otherwise, it damages the Box.

The table describes the additional modules for the UPS:

Input power	UPS	Additional modules	Reference
DC	No	–	–
	Yes	UPS module / UPS cables	PFXZPBEUUPB2 / PFXZPBCBUP32
AC	No	AC power supply module	PFXZPBPUAC2
	Yes	UPS module / UPS cable and AC power supply module	PFXZPBEUUPB2 / PFXZPBCBUP32 and PFXZPBPUAC2

NOTE: If the configuration of the Box has a PCIe/PCI cards and Ethernet PoE optional interface then the UPS is not compatible.

UPS Module Description

The UPS module is subject to wear and should be replaced regularly, depend on the battery. This information is displayed by **System Monitor**. The **Health** status shows battery needs to be changed.

When UPS cannot get power source, and into backup mode, after 5 minutes, backup power is almost exhausted. This behavior depends on Power Button setting of the OS. The UPS sends event ask operation system shut down before backup power is exhausted. If UPS module gets the power source again, in **AT** mode (setting by Box BIOS menu), Box restarts automatically, in **ATX** mode (setting by Box BIOS menu), it need push power button for system booting.

The figure shows the UPS module (PFXZPBUEUPB2):

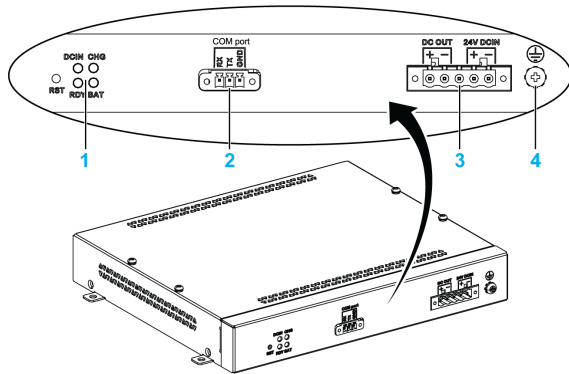

- 1 LEDs ([DCIN / CHG / RDY / BAT]) and button ([RST])
- 2 Communication port connector ([COM port / PWR])
- 3 DC power connector ([DC OUT / 24V DCIN])
- 4 Ground connection pin

The table describes the meaning of the status indicator:

Label	Color	State	Meaning
[DCIN]	Green	ON	The input source is OK. DC_IN loss over 5 minute, 1 Hz blinking.
[CHG]	Green	1 Hz Flashing	The UPS module is in charge.
		0.5 Hz Flashing	The battery status is abnormal.
[RDY]	Yellow	ON	The UPS module is ready.
[BAT]	Blue	ON	The battery of the UPS module is loading.
		0.5 Hz Flashing	The battery status is abnormal.

NOTE: The button **RST** is a reset of the UPS module.

The table shows the technical data of the UPS module:

Features	Values
UPS	
Input voltage	18...36 Vdc
Output voltage	24 Vdc
Output current	3 A
Communication port	COM port / RS-232
Back-up time	10 minutes (battery 70 % full)

Features	Values
Operating temperature	0...45 °C (32...113 °F)
Mounting	Desktop mount
Battery cells	
Capacity:	27.5 Wh (2.73 Ah, 4S1P)
Maximum discharger current	9 A (discharged at high rate and high temperature frequently, battery life is shortening)
Charging current (max)	1 A
Operating voltage	12...16 Vdc
Cycle life of recharging	300 times
Operating temperature	Charge: 0...45 °C (32...113 °F) Discharge: 0...60 °C (32...140 °F)
Typical recharge time at low battery	4 hours
Weight	1.15 Kg (2.53 lbs)

The figure shows the dimensions of the UPS module (PFXZPBUEUPB2) equipped with the optional AC power supply module (PFXZPBPUAC2):

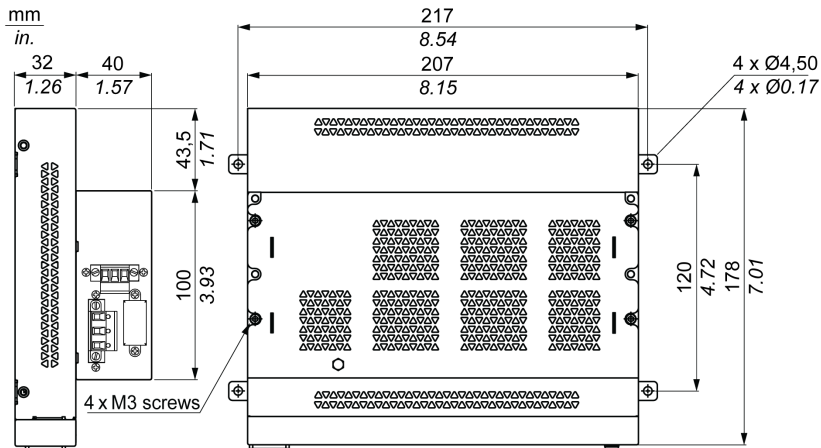

Installing Instructions

Before installing the UPS system, shut down Windows operating system in an orderly fashion and remove all power from the device.

⚡ ⚠ DANGER

HAZARD OF ELECTRIC SHOCK, EXPLOSION OR ARC FLASH

- Remove all power from the device before removing any covers or elements of the system, and prior to installing or removing any accessories, hardware, or cables.
- Unplug the power cable from both the Box and the power supply.
- Always use a properly rated voltage sensing device to confirm power is off.
- Replace and secure all covers or elements of the system before applying power to the unit.
- Use only the specified voltage when operating the Box. The AC unit is designed to use 100...240 Vac input. The DC unit is designed to use 24 Vdc input. Always check whether your device is AC or DC powered before applying power.

Failure to follow these instructions will result in death or serious injury.

By adding the charging circuit in the Box housing, installation is reduced to merely attaching the connection cable to the UPS module mounted next to the Box.

NOTE: Due to the construction of these batteries, you can store and operate the UPS module in any position.

Follow the steps when installing the UPS module equipped with the optional AC power supply module:

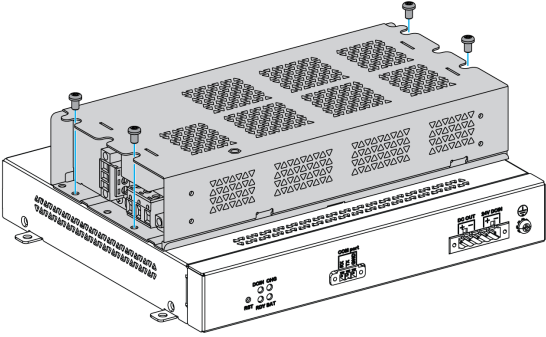
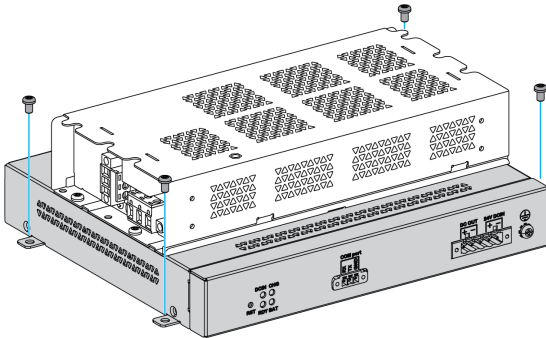
Step	Action
1	Disconnect the power supply of the Box.
2	Touch the housing or ground connection (not the power supply) to discharge any electrostatic charge from your body.
3	Mount the AC power supply module on the UPS module with the four screws supplied: 
4	Install the UPS module (PFXZPBUEUPB2). The installation requires four M4 screws: 
5	Connect the two UPS cables (PFXZPBCBUP32) to the UPS module. Be sure to use the right connection terminals.

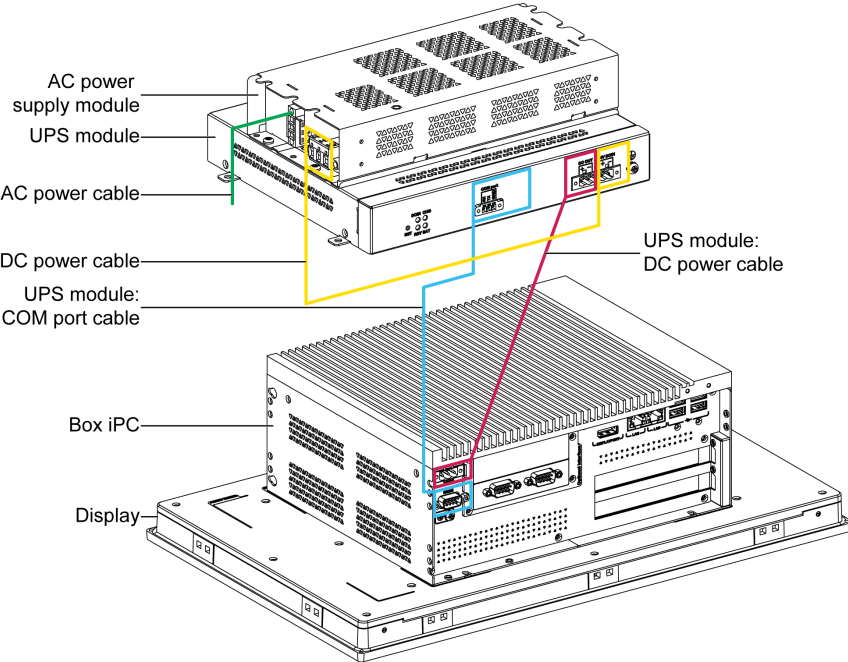
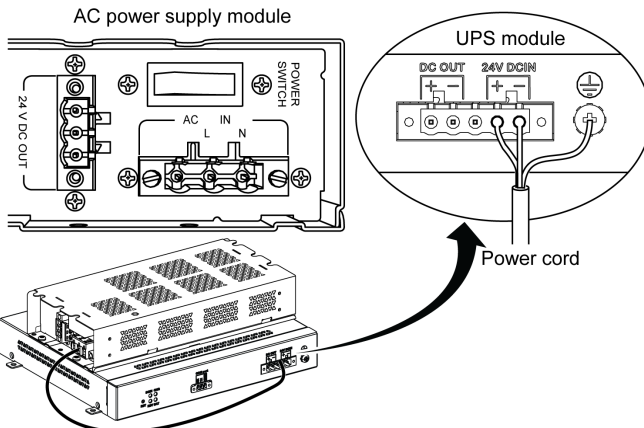
Step	Action
6	<p>Connect the DC power cable of the UPS module at the DC power connector of the Box Connect the COM port cable of the UPS module at the [COM1] port of the Box:</p>  <p>Tighten the connected cables in the screw clamps.</p>
7	<p>Connect the AC power supply module ([24V DCOUT]) to the DC power cable ([24V DCIN]) of the UPS module:</p> 

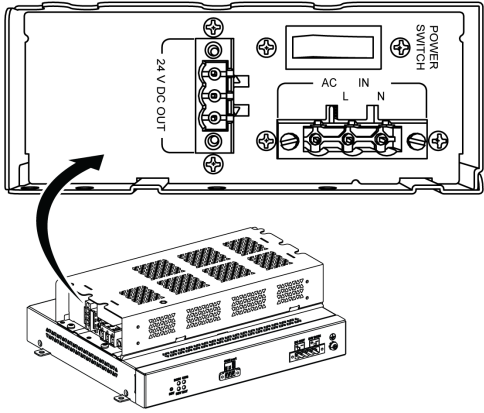
Step	Action
8	<p>Connect the AC power cable ([AC IN]) of the AC power supply module:</p> 

Follow the steps when installing the UPS module without the optional AC power supply module:

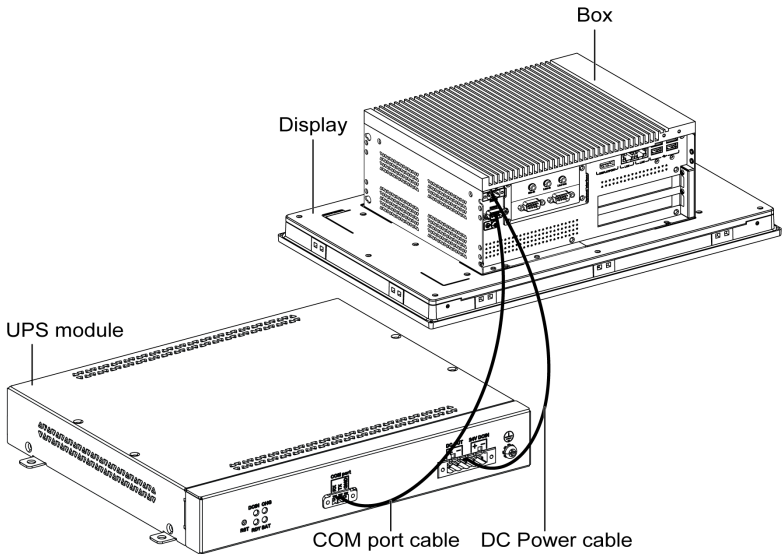
Step	Action
1	Disconnect the power supply of the Box.
2	Touch the housing or ground connection (not the power supply) to discharge any electrostatic charge from your body.
3	Install the UPS module (PFXZPBEUUPB2). The installation requires four x M5 screws and four washers.
4	Connect the two UPS cables (PFXZPBCBUP32) to the UPS module. Be sure to use the right connection terminals.
5	<p>Connect the DC power cable at the DC power connector of the Box Connect the communication cable (COM port) at the COM1 port RS-232 of the Box:</p>  <p>Tighten the connected cables in the screw clamps.</p>

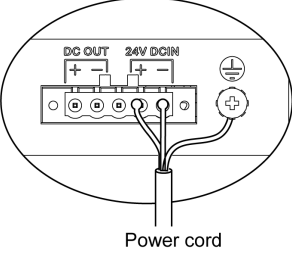
Step	Action
6	<p>Connect the DC power supply ([24V DCIN]) of the UPS module from its power source:</p>  <p>Power cord</p>

CAUTION

OVERTORQUE AND LOOSE HARDWARE

- Do not exert more than 0.5 Nm (4.5 lb-in) of torque when tightening the installation fastener, enclosure, accessory, or terminal block screws. Tightening the screws with excessive force can damage the installation fastener.
- When fastening or removing screws, ensure they do not fall inside the Box chassis.

Failure to follow these instructions can result in injury or equipment damage.

Box Interface Connections

Introduction

The Boxes PFXPP2B, PFXPU2B, PFXPP27, PFXPP2J, PFXPU27, PFXPU2J, and the Display Adapter PFXZPPDADDP2 are classified hazardous locations Class I Division 2 (see chapter "Certifications and Standards"). Observe the following:

DANGER

POTENTIAL FOR EXPLOSION

- Always confirm the ANSI/ISA 12.12.01 and CSA C22.2 N°213 hazardous location rating of your device before installing or using it in a hazardous location.
- To power on or power off a Box installed in a Class I, Division 2 hazardous location, you must either:
 - Use a switch located outside the hazardous environment, or
 - Use a switch certified for Class I, Division 1 operation inside the hazardous area.
- Do not connect or disconnect equipment unless power has been switched off or the area is known to be non-hazardous. This applies to all connections including power, ground, serial, parallel, network, and rear USB connections.
- Never use unshielded / ungrounded cables in hazardous locations.
- When enclosed, keep enclosure doors and openings closed at all times to avoid the accumulation of foreign matter inside the workstation.
- Do not use front USB and keep the cover in place.
- Do not expose to direct sunlight or UV light source.

Failure to follow these instructions will result in death or serious injury.

The Box PFXPP2L, PFXPP2N, PFXPU2L, PFXPU2N and the Display Module PFXPPD5800WP, PFXPPD5900WP are not classified hazardous locations.

DANGER

POTENTIAL FOR EXPLOSION IN HAZARDOUS LOCATION

Do not use this product in hazardous locations.

Failure to follow these instructions will result in death or serious injury.

WARNING

EQUIPMENT DISCONNECTION OR UNINTENDED EQUIPMENT OPERATION

- Ensure that power, communication, and accessory connections do not place excessive stress on the ports. Consider the vibration in the environment.
- Securely attach power, communication, and external accessory cables to the panel or cabinet.
- Use only D-Sub 9-pin connector cables with a locking system in good condition.
- Use only commercially available USB cables.

Failure to follow these instructions can result in death, serious injury, or equipment damage.

Serial Interface Connections

This interface is used to connect the Box to remote equipment, via a serial interface cable. The connector is a D-Sub 9-pin plug connector.

By using a long PLC cable to connect to the Box, it is possible that the cable can be at a different electrical potential than the panel, even if both are connected to ground.

NOTE: The Box can get UPS information from COM port. Only COM1 can be used to detect UPS module information (PFXZPBUEUPB2). The communication module of the optional interface cannot use for UPS module; otherwise, it damages the Box.

DANGER

ELECTRIC SHOCK

- Make a direct connection between the ground connection screw and ground.
- Do not connect other devices to ground through the ground connection screw of this device.
- Install all cables according to local codes and requirements. If local codes do not require grounding, follow a reliable guide such as the US National Electrical Code, Article 800.

Failure to follow these instructions will result in death or serious injury.

The table shows the D-Sub 9-pin assignments (COM1):

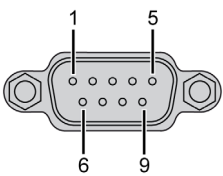
Pin	Assignment			D-Sub 9-pin plug connector
	RS-232	RS-422	RS-485	
1	DCD	TxD-	Data-	
2	RxD	TxD+	Data+	
3	TxD	RxD+	N/A	
4	DTR	RxD-	N/A	
5	GND	GND	GND	
6	DSR	N/A	N/A	
7	RTS	N/A	N/A	
8	CTS	N/A	N/A	
9	RI	N/A	N/A	

Any excessive weight or stress on communication cables may disconnect the equipment.

NOTE: Adjust the serial port configuration with DIP switch. You can select RS-232, RS-422, or RS-485. The RS-485 port is designed with auto data flow control capability and automatically detects the data flow direction.

The figure shows the position of the SW1:

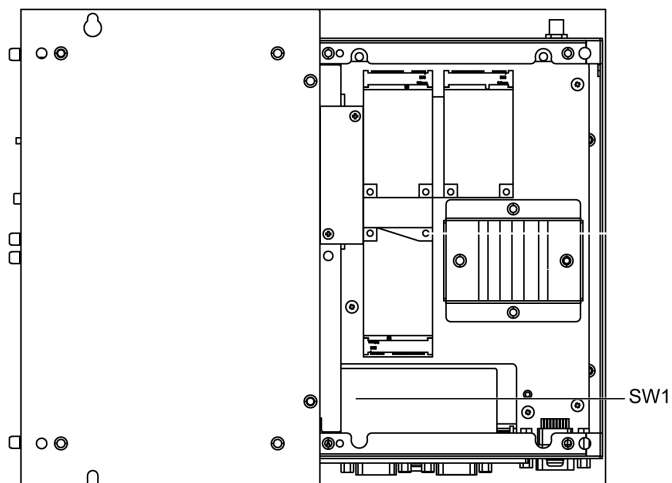

The table describes the RS-232, RS-422/485 mode settings for the COM1:

Mode	SW1
RS-232 mode	
RS-422 master mode	

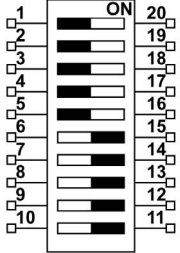
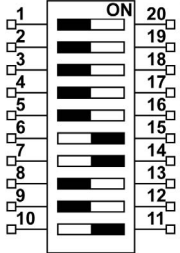
Mode	SW1
RS-422 slave mode	
RS-485 mode	

NOTE: The RS-422 enables to create point-to-multipoint connections. In a point-to-multipoint arrangement, the node originating the data (master) can broadcast data to several (slave) nodes at once.

RS-422 can be configured as master mode or slave mode for networking. A master-slave system has one master node that issues commands to each of the slave nodes and processes responses. Slave nodes do not typically transmit data without a request from the master node, and do not communicate with each other. Each slave must have a unique address so that it can be addressed independently of other nodes.

RJ45 Connector Status LEDs

The figure shows the RJ45 connector status LEDs:

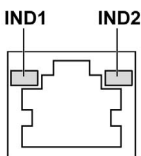

The table describes the RJ45 connector status LED:

Label	Description	LED		
		Color	Status	Description
IND1	Ethernet link	Green/Yellow	Off	Link at 10 Mbit/s
			Solid yellow	Link at 100 Mbit/s
			Solid green	Activity at 1000 Mbit/s
IND2	Ethernet activity	Green	Off	No activity
			On	Transmitting or receiving data

Chapter 8

Configuration of the BIOS

What Is in This Chapter?

This chapter contains the following topics:

Topic	Page
BIOS Main Menu	104
Advanced Menu	105
Chipset Menu	107
Boot Menu	109
Security Menu	110
Save & Exit Menu	111

BIOS Main Menu

General Information

BIOS stands for **Basic Input Output System**.

The **BIOS Setup Utility** lets you modify basic system configuration settings.

NOTE: To enter BIOS setup, press **DEL** key during startup.

Main Tab

When you press the [DEL] key during startup, the **Main** BIOS setup menu appears.

This screen, like all the BIOS screens, is divided into three frames:

- Left: This frame displays the options available on the screen.
- Upper right: This frame gives a description of the user selected option.
- Lower right: This frame displays how to move to other screens and the screen edit commands.

This table shows the **Main** menu options that can be set by the user:

BIOS setting	Description
System Time	This is the current time setting. The time must be entered in HH:MM:SS format. The time is maintained by the battery (CMOS battery) when the unit is turned off.
System Date	This is the current date setting. The date must be entered in MM/DD/YY format. The date is maintained by the battery (CMOS battery) when the unit is turned off.

NOTE: The grayed-out options on all BIOS screens cannot be configured. The blue options can be configured by the user.

Advanced Menu

Advanced BIOS Features Tab

For details about the Advanced submenus, refer to:

- CPU Configuration
- SATA Configuration
- USB Configuration
- IT8768 Super I/O Configuration
- iManager Configuration

CPU Configuration Menu

BIOS setting	Description
Hyper-threading	Enables or disables the Intel hyper threading technology.
Execute Disable Bit	Enables or disables the no-execution page protection.
Intel Virtualization Technology	Enables or disables Intel virtualization technology. When enabled, a VMM can utilize the additional hardware capabilities provided by Vanderpool technology.
EIST	Enables or disables Intel SpeedStep.
Turbo Mode	Enables or disables CPU Turbo Mode.
Energy Performance	Select CPU performance or power savings Mode.
CPU C states	Enables or disables CPU C states.

SATA Configuration Menu

BIOS setting	Description
SATA Controller(s)	Enables or disables SATA devices.
SATA Mode Selection	Select SATA mode selection. (Determines how SATA controllers operate).
SATA Controller Speed	Indicates the maximum speed the SATA controller can support.
CFast	CFast: Enables or disables serial ATA port. Hot plug: Designates this port as hot pluggable.
mSATA	mSATA: Enables or disables serial ATA port. Hot plug: Designates this port as hot pluggable.
HDD1	HDD1: Enables or disables serial ATA port. Hot plug: Designates this port as hot pluggable.
HDD2	HDD2: Enables or disables serial ATA port. Hot plug: Designates this port as hot pluggable.

USB Configuration Menu

BIOS setting	Description
USB Mass Storage Driver Support	Enables or disables USB mass storage driver support.
USB transfer time-out	Select time-out section. The time-out value for control, bulk, and interrupt transfers.
Device reset time-out	Select device time-out section. USB mass storage devices start unit command time-out.
Device power-up delay	Select device power-up section. Maximum time the device takes before it properly reports itself to the host controller. Auto uses a default value: for a root port it is 100 ms, for a hub port the delay is taken from the hub descriptor.

IT8768 Super IO Configuration Menu

BIOS setting	Description
Serial Port 1 Configuration	This item allows user to set parameters of COM port 1.

iManager Configuration Menu

BIOS setting	Description
CPU Shutdown Temperature	Select CPU shutdown temperature.
iManager WatchDog IRQ	Select iManager IRQ number eBrain watchdog.
Hardware Monitor	Monitor hardware status.

Chipset Menu

Chipset BIOS Features Tab

For details about the **Chipset** submenus, refer to:

- PCH-IO configuration
- System agent (SA) Configuration

PCH-IO Configuration Menu

BIOS setting	Description
PCI Express Configuration	Change mini PCIe configuration settings.
USB Configuration	Change USB configuration settings.
PCH Azalia Configuration	Azalia (Intel High Definition Audio)
Restore AC Power Loss	Select AC power state when power is reapplied after a power outage.

PCI Express Configuration Submenu

BIOS setting	Description
mPCIe1	Change mini PCIe root settings: <ul style="list-style-type: none"> • mPCIe1 • Hot Plug • PCIe Speed
mPCIe2	Change mini PCIe root settings: <ul style="list-style-type: none"> • mPCIe1 • Hot Plug • PCIe Speed
PClex1	Change mini PCIe root settings: <ul style="list-style-type: none"> • mPCIe1 • Hot Plug • PCIe Speed
PClex4	Change mini PCIe root settings: <ul style="list-style-type: none"> • mPCIe1 • Hot Plug • PCIe Speed

USB Configuration Submenu

BIOS setting	Description
USB Precondition	Enables or disables USB Precondition. Precondition work on USB host controller and root ports for faster enumeration.
XHCI Mode	Select mode of operation of XHCI mode.
USB Ports Per-Port Control	Enables or disables each of the USB port.

System Agent (SA) Configuration Menu

BIOS setting	Description
VT-d	Enables or disables VT-d function.
Graphics Configuration	Change graphics setting.

Graphics Configuration Submenu

BIOS setting	Description
Graphics Turbo IMON Current	Shows graphics turbo IMON current values supported (14-31).
Primary Display	Select which of the IGFX/PEG/PCI graphics device should be the primary display or select the SG for switchable Gfx.

Boot Menu

Boot Settings Configuration Menu

Boot setting	Description
Setup Prompt Timeout	Select the number of seconds to wait for setup activation key.
Bootup NumLock state	Select the keyboard NumLock state.
Quiet Boot	Enables or disables Quiet Boot option.
Fast Boot	Enables or disables boot with initialization of a minimal set of devices required to launch active boot option. It has no effect for BBS boot options.

CSM Parameters Submenu

Boot setting	Description
Launch CSM	Enables or disables launch CSM.
Boot option filter	Select boot option filter setting.
Launch PXE OpROM policy	Select launch PXE OpROM policy setting.
Launch Storage OpROM policy	Select launch storage OpROM policy setting.
Launch Video OpROM policy	Select launch video OpROM policy setting.
Other PCI device ROM priority	Select other PCI device ROM priority setting.

Security Menu

Security Setup

Select **Security Setup** from the main BIOS setup menu. All **Security Setup** options, such as password protection, are described in this section. To access the submenu for the following items, select the item and press **Enter**.

To change the administrator or user password, select the **Administrator / User Password** option, press **Enter** to access the submenu, and then type the password.

Save & Exit Menu

Menu

BIOS setting	Description
Save Changes and Exit	When the system configuration is complete, select this option to save changes, exiting the BIOS setup and, if necessary, reboot the computer to take into account all system configuration parameters.
Discard Changes and Exit	Select this option to quit setup without making any permanent changes to the system configuration.
Save Changes and Reset	Selecting this option displays a confirmation message box. On confirming, you save changes to the BIOS settings, save the settings to CMOS, and restart the system.
Discard Changes and Reset	Select this option to quit BIOS setup without making any permanent changes to the system configuration and reboot the computer.
Save Changes	Select this option to save the system configuration changes without exiting the BIOS setup menu.
Discard Changes	Select this option to discard any current changes and load previous system configuration.
Restore Defaults	Select this option to configure automatically all BIOS setup items to the optimal default settings. The optimal defaults are designed for maximum system performance, but may not work best for all computer applications. Do not use the optimal defaults if the user's computer is experiencing system configuration problems.
Save User Defaults	When the system configuration is complete, select this option to save changes as the user defaults without exit BIOS setup menu.
Restore User Defaults	Select this option to restore the user defaults.

Chapter 9

Hardware Modifications

Subject of This Chapter

This chapter describes the hardware modifications for the Box.

What Is in This Chapter?

This chapter contains the following sections:

Section	Topic	Page
9.1	Before Modifications	114
9.2	Box and Storage Modifications	116
9.3	Box and Fan Kit Installation	130
9.4	Box and Optional Interfaces	132

Section 9.1

Before Modifications

Before Making Modifications

Introduction

For detailed installation procedures for optional units, refer to the OEM (Original equipment manufacturer) Installation guide included with the optional unit.

 **DANGER**

HAZARD OF ELECTRIC SHOCK, EXPLOSION OR ARC FLASH

- Remove all power from the device before removing any covers or elements of the system, and prior to installing or removing any accessories, hardware, or cables.
- Unplug the power cable from both the Box and the power supply.
- Always use a properly rated voltage sensing device to confirm power is off.
- Replace and secure all covers or elements of the system before applying power to the unit.
- Use only the specified voltage when operating the Box. The DC unit is designed to use 24 Vdc input.

Failure to follow these instructions will result in death or serious injury.

The Boxes PFXPP2B, PFXPU2B, PFXPP27, PFXPP2J, PFXPU27, PFXPU2J, and the Display Adapter PFXZPPDADDP2 are classified hazardous locations Class I Division 2 (see chapter "Certifications and Standards"). Observe the following:

 **DANGER**

POTENTIAL FOR EXPLOSION

- Always confirm the ANSI/ISA 12.12.01 and CSA C22.2 N°213 hazardous location rating of your device before installing or using it in a hazardous location.
- To power on or power off a Box installed in a Class I, Division 2 hazardous location, you must either:
 - Use a switch located outside the hazardous environment, or
 - Use a switch certified for Class I, Division 1 operation inside the hazardous area.
- Do not connect or disconnect equipment unless power has been switched off or the area is known to be non-hazardous. This applies to all connections including power, ground, serial, parallel, network, and rear USB connections.
- Never use unshielded / ungrounded cables in hazardous locations.
- When enclosed, keep enclosure doors and openings closed at all times to avoid the accumulation of foreign matter inside the workstation.
- Do not use front USB and keep the cover in place.
- Do not expose to direct sunlight or UV light source.

Failure to follow these instructions will result in death or serious injury.

NOTE: When using a Display Module PFXPPD5700TA or a Display Module PFXPPD5700WP with the Box Celeron and Box Core i7 (classified hazardous locations) can be classified hazardous locations.

NOTE: When using DC power supply, Display Adapter (PFXZPPDADDP2) with the Display Module can be classified hazardous locations. When using AC power supply, the Display Adapter with the Display Module and the AC power supply adapter for 100 W (PFXZPBPUAC2) can be classified hazardous locations.

The Box PFXPP2L, PFXPP2N, PFXPU2L, PFXPU2N and the Display Module PFXPPD5800WP, PFXPPD5900WP are not classified hazardous locations.

DANGER

POTENTIAL FOR EXPLOSION IN HAZARDOUS LOCATION

Do not use this product in hazardous locations.

Failure to follow these instructions will result in death or serious injury.

During operation, the surface temperature of the heat sink may exceed 70 °C (158 °F).

WARNING

RISK OF BURNS

Do not touch the surface of the heat sink during operation.

Failure to follow these instructions can result in death, serious injury, or equipment damage.

CAUTION

OVERTORQUE AND LOOSE HARDWARE

- Do not exert more than 0.5 Nm (4.5 lb-in) of torque when tightening the installation fastener, enclosure, accessory, or terminal block screws. Tightening the screws with excessive force can damage the installation fastener.
- When fastening or removing screws, ensure they do not fall inside the Box chassis.

Failure to follow these instructions can result in injury or equipment damage.

CAUTION

STATIC SENSITIVE COMPONENTS

Box Internal components, including accessories such as RAM modules and expansion boards, can be damaged by static electricity.

- Keep static-producing materials (plastic, upholstery, carpeting) out of the immediate work area.
- Do not remove ESD-sensitive components from their anti-static bags until you are ready to install them.
- When handling static-sensitive components, wear a properly grounded wrist strap (or equivalent).
- Avoid unnecessary contact with exposed conductors and component leads with skin or clothing.

Failure to follow these instructions can result in injury or equipment damage.

Section 9.2

Box and Storage Modifications

Overview

This section shows the installation of the HDD/SSD drives, the CFast card and the mSATA card.

What Is in This Section?

This section contains the following topics:

Topic	Page
HDD/SSD Drive Installation	117
Memory Card Installation	120
mSATA Card Installation	122
mini PCIe and PCI/PCIe Card Installation	125

HDD/SSD Drive Installation

Overview

The Box supports three types of SATA devices and four SATA ports. The table shows the SATA device configuration:

SATA port	SATA device	SATA speed
Port 1	mSATA	6 Gb/s; 3 Gb/s; 1.5 Gb/s
Port 2	CFast	
Port 3	HDD/SSD 1	
Port 4	HDD/SSD 2	

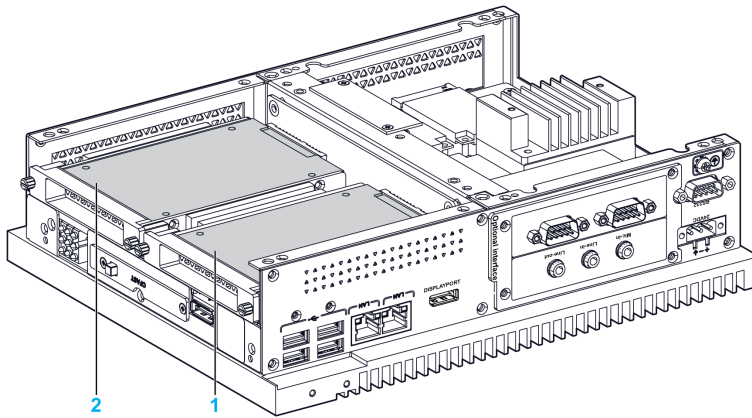

- 1 HDD/SSD 1
- 2 HDD/SSD 2

The Box supports RAID 0/1 feature (2 x HDD or 2 x SSD can support this feature).

Use Intel rapid storage technology (Intel RST) to support RAID 0/1 feature (see the Intel rapid storage user manual on the recovery media):

- RAID level 0 performance scaling up to six drives, enabling higher throughput for data intensive applications such as video editing.
- Data redundancy is offered through RAID level 1, which performs mirroring.

The Box supports HDD or SSD SATA hot-swap feature:

SATA RAID	Description	Hot-Swap
RAID 0	Spanned volume	No
RAID 1	Mirroring	Yes

HDD/SSD Drive Installation

NOTICE

ELECTROSTATIC DISCHARGE

Take the necessary protective measures against electrostatic discharge before attempting to remove the Box cover.

Failure to follow these instructions can result in equipment damage.

⚠ CAUTION

OVERTORQUE AND LOOSE HARDWARE

- Do not exert more than 0.5 Nm (4.5 lb-in) of torque when tightening the installation fastener, enclosure, accessory, or terminal block screws. Tightening the screws with excessive force can damage the installation fastener.
- When fastening or removing screws, ensure they do not fall inside the Box chassis.

Failure to follow these instructions can result in injury or equipment damage.

NOTE: Remove all power before attempting this procedure.

This table describes how to install an HDD/SSD drive:

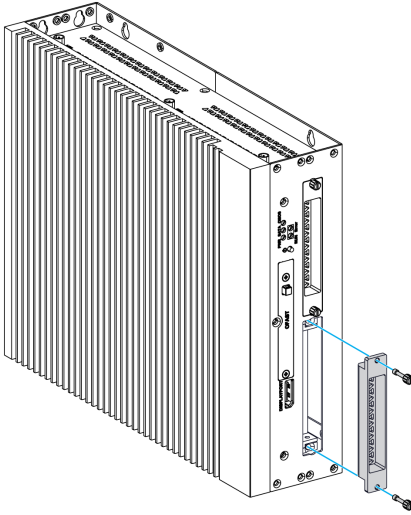
Step	Action
1	Disconnect the power cord to the Box.
2	Touch the housing or ground connection (not the power supply) to discharge any electrostatic charge from your body.
3	Remove the two screws of the front cover and remove it: <div style="text-align: center;">  </div>

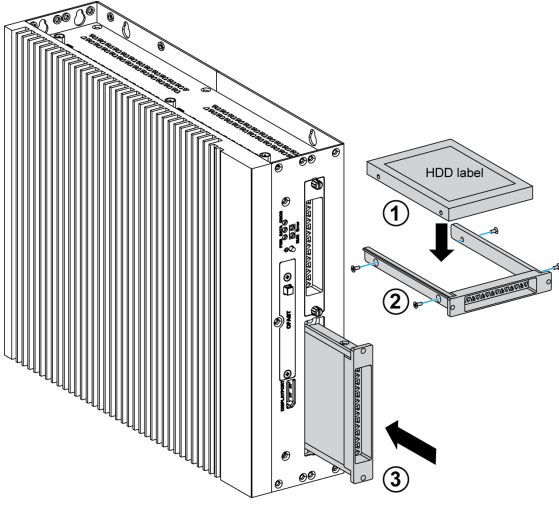
Step	Action
4	<p data-bbox="353 202 1248 280">Install the 2.5" SATA HDD/SSD on the HDD/SSD bracket of the slide-in (PFXZPBADHDD2). Screw in the four screws on the side of HDD/SSD bracket (the screws are in the accessory box). Insert the HDD/SSD drive inside the slot:</p>  <p data-bbox="353 299 912 801">The diagram illustrates the installation process. On the left is the main device with a vertical slot. On the right, a bracket is being prepared. Step 1 shows a screw being inserted into the bracket. Step 2 shows a second screw being inserted. Step 3 shows the bracket being inserted into the slot of the main device. An HDD label is shown above the bracket.</p>
5	<p data-bbox="353 840 1008 869">Replace the front cover. Secure the front cover using the two screws.</p> <p data-bbox="353 879 1104 908">NOTE: The recommended torque to tighten these screws is 0.5 Nm (4.5 lb-in).</p>

Memory Card Installation

Introduction

The Box operating system views the CFast card as a hard disk. Proper handling and care of the CFast card helps extend the life of the card. Familiarize yourself with the card before attempting to insert or remove the card.

Before installing or removing a memory card, shut down Windows operating system in an orderly fashion and remove all power from the device.

DANGER

HAZARD OF ELECTRIC SHOCK, EXPLOSION OR ARC FLASH

- Remove all power from the device before removing any covers or elements of the system, and prior to installing or removing any accessories, hardware, or cables.
- Unplug the power cable from both the Box and the power supply.
- Always use a properly rated voltage sensing device to confirm power is off.
- Replace and secure all covers or elements of the system before applying power to the unit.
- Use only the specified voltage when operating the Box. The AC unit is designed to use 100...240 Vac input. The DC unit is designed to use 24 Vdc input. Always check whether your device is AC or DC powered before applying power.

Failure to follow these instructions will result in death or serious injury.

CAUTION

MEMORY CARD DAMAGE AND DATA LOSS

- Remove all power before making any contact with an installed memory card.
- Use only memory cards sold by Pro-face as accessory for this product. The performance of the Box has not been tested using memory cards from other manufacturers.
- Confirm that the memory card is correctly oriented before insertion.
- Do not bend, drop, or strike the memory card.
- Do not touch the memory card connectors.
- Do not disassemble or modify the memory card.
- Keep the memory card dry.

Failure to follow these instructions can result in injury or equipment damage.

NOTICE

ELECTROSTATIC DISCHARGE

Take the necessary protective measures against electrostatic discharge before attempting to remove the Box cover.

Failure to follow these instructions can result in equipment damage.

Inserting the Memory Card

The procedure describes how to insert the memory card.

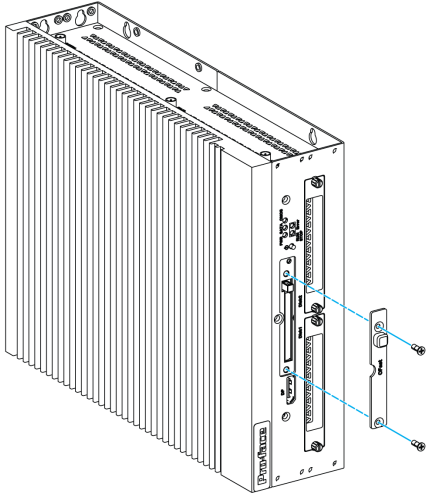
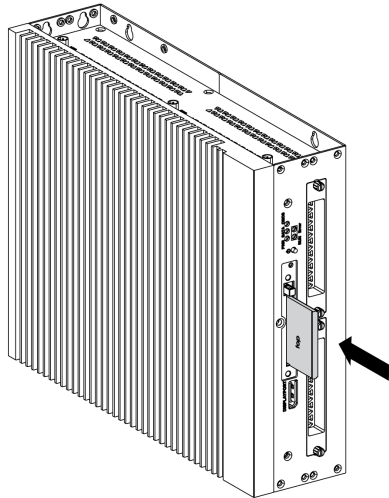
Step	Action
1	Remove the two screws of the cover of the CFAST card: 
2	Insert the CFAST card into the card slot. Press the CFAST card slot firmly into the Box. Replace the front cover. Secure the front cover using the two screws: 

CFAST Card Installation

Refer to the relevant procedure in the software installation guide for the Box and terminals. The installation guide is shipped with the product.

mSATA Card Installation

Introduction

The Box operating system views the mSATA card as a hard disk. Proper handling and care of the mSATA card helps extend the life of the card. Familiarize yourself with the card before attempting insertion or removal of the card.

The Box supports three types of SATA devices and four SATA ports. The table shows the SATA device configuration:

SATA port	SATA device	SATA speed
Port 1	mSATA	6 Gb/s; 3 Gb/s; 1.5 Gb/s
Port 2	CFast	
Port 3	HDD/SSD 1	
Port 4	HDD/SSD 2	

Before installing or removing a card, shut down Windows operating system in an orderly fashion and remove all power from the device.

DANGER

HAZARD OF ELECTRIC SHOCK, EXPLOSION OR ARC FLASH

- Remove all power from the device before removing any covers or elements of the system, and prior to installing or removing any accessories, hardware, or cables.
- Unplug the power cable from both the Box and the power supply.
- Always use a properly rated voltage sensing device to confirm power is off.
- Replace and secure all covers or elements of the system before applying power to the unit.
- Use only the specified voltage when operating the Box. The AC unit is designed to use 100...240 Vac input. The DC unit is designed to use 24 Vdc input. Always check whether your device is AC or DC powered before applying power.

Failure to follow these instructions will result in death or serious injury.

CAUTION

MEMORY CARD DAMAGE AND DATA LOSS

- Remove all power before making any contact with an installed memory card.
- Use only memory cards sold by Pro-face as accessory for this product. The performance of the Box has not been tested using memory cards from other manufacturers.
- Confirm that the memory card is correctly oriented before insertion.
- Do not bend, drop, or strike the memory card.
- Do not touch the memory card connectors.
- Do not disassemble or modify the memory card.
- Keep the memory card dry.

Failure to follow these instructions can result in injury or equipment damage.

NOTICE

ELECTROSTATIC DISCHARGE

Take the necessary protective measures against electrostatic discharge before attempting to remove the Box cover.

Failure to follow these instructions can result in equipment damage.

mSATA Card Installation

The procedure describes how to insert the mSATA card.

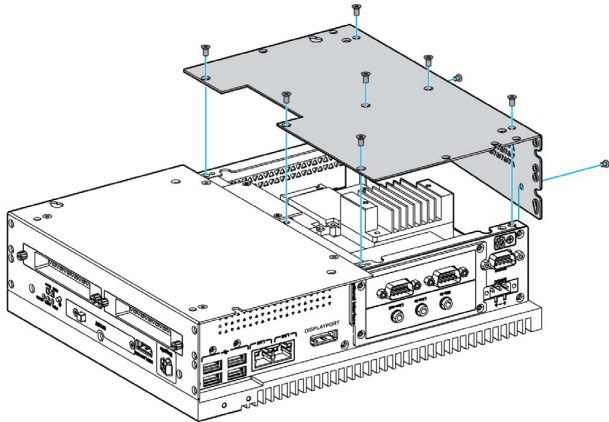
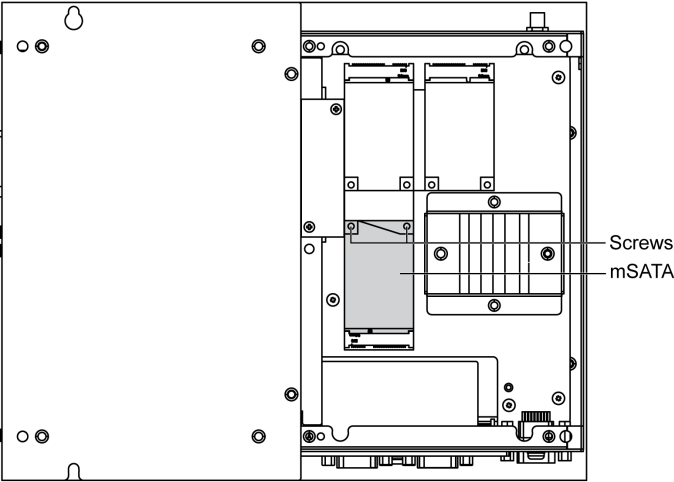
Step	Action
1	Disconnect the power cord to the Box.
2	Touch the housing or ground connection (not the power supply) to discharge any electrostatic charge from your body.
3	Unscrew the nine screws from the cover and remove it: <div style="text-align: center;">  </div>
4	Insert the mSATA card firmly into the card slot and fasten it with two screws: <div style="text-align: center;">  </div>

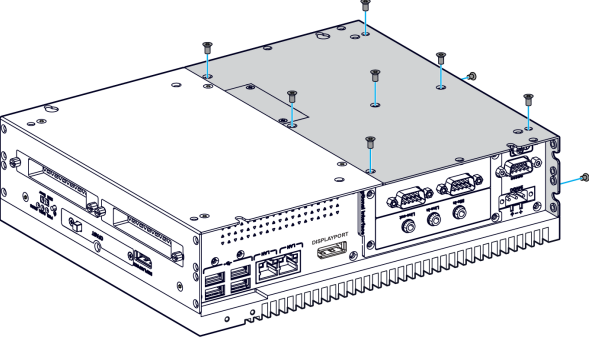
Step	Action
5	<p data-bbox="326 204 788 227">Replace the cover and fasten it with nine screws:</p>  <p data-bbox="326 633 1074 656">NOTE: The recommended torque to tighten these screws is 0.5 Nm (4.5 lb-in).</p>

mSATA Card Data Backup

Refer to the relevant procedure in the software installation guide for the Box and terminals. The installation guide is shipped with the product.

mini PCIe and PCI/PCIe Card Installation

Introduction

The Box supports two PCI/PCIe slots and two mini PCIe slots.

NOTE: The operating temperature is limited to 45 °C (113 °F) and the fan kit (PFXZPBIUFAN2) is required for PCI/PCIe cards installed on board with power consumption from 3 W to 6 W maximum for two cards or 10 W maximum for one card.

NOTE: The operating temperature is limited to 45 °C (113 °F) and the fan kit (PFXZPBIUFAN2) is required for the Ethernet PoE interface module (PFXZPBMPPE2).

Before installing or removing a mini PCIe or PCI/PCIe cards shut down Windows operating system in an orderly fashion and remove all power from the device.

DANGER

HAZARD OF ELECTRIC SHOCK, EXPLOSION OR ARC FLASH

- Remove all power from the device before removing any covers or elements of the system, and prior to installing or removing any accessories, hardware, or cables.
- Unplug the power cable from both the Box and the power supply.
- Always use a properly rated voltage sensing device to confirm power is off.
- Replace and secure all covers or elements of the system before applying power to the unit.
- Use only the specified voltage when operating the Box. The AC unit is designed to use 100...240 Vac input. The DC unit is designed to use 24 Vdc input. Always check whether your device is AC or DC powered before applying power.

Failure to follow these instructions will result in death or serious injury.

CAUTION

MEMORY CARD DAMAGE AND DATA LOSS

- Remove all power before making any contact with an installed memory card.
- Use only memory cards sold by Pro-face as accessory for this product. The performance of the Box has not been tested using memory cards from other manufacturers.
- Confirm that the memory card is correctly oriented before insertion.
- Do not bend, drop, or strike the memory card.
- Do not touch the memory card connectors.
- Do not disassemble or modify the memory card.
- Keep the memory card dry.

Failure to follow these instructions can result in injury or equipment damage.

NOTICE

ELECTROSTATIC DISCHARGE

Take the necessary protective measures against electrostatic discharge before attempting to remove the Box cover.

Failure to follow these instructions can result in equipment damage.

mini PCIe Card Installation

The table describes how to install a mini PCIe card:

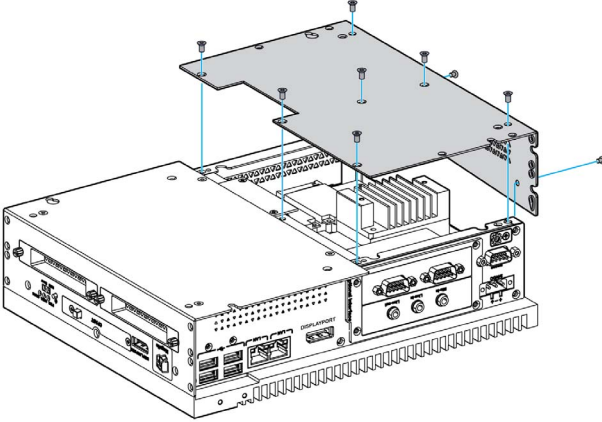
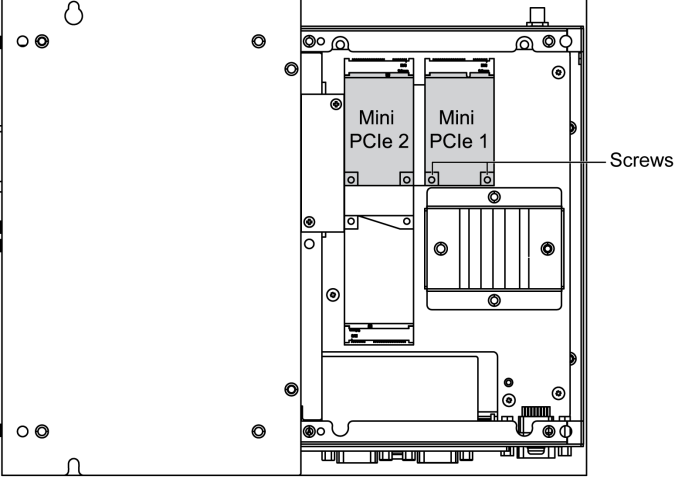
Step	Action
1	Disconnect the power cord to the Box.
2	Touch the housing or ground connection (not the power supply) to discharge any electrostatic charge from your body.
3	<p>Unscrew the nine screws from the cover and remove it:</p> 
4	<p>Insert the mini PCIe card into the expansion card connector and fasten it with two screws:</p>  <p>When using a mini PCIe card with an external cable attached, install a clamp or other device to secure the cable.</p> <p>NOTE: The recommended torque to tighten these screws is 0.5 Nm (4.5 lb-in).</p>

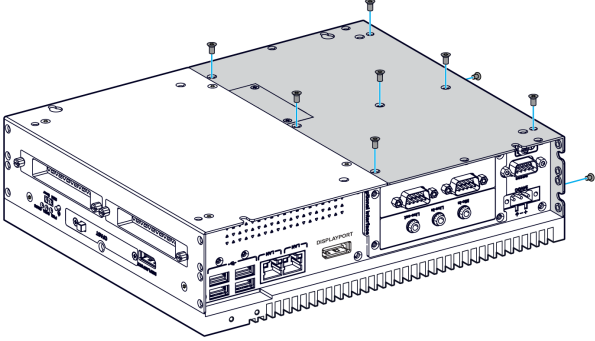
Step	Action
5	Replace the cover and fasten it with nine screws: 

⚠ CAUTION

OVERTORQUE AND LOOSE HARDWARE

- Do not exert more than 0.5 Nm (4.5 lb-in) of torque when tightening the installation fastener, enclosure, accessory, or terminal block screws. Tightening the screws with excessive force can damage the installation fastener.
- When fastening or removing screws, ensure they do not fall inside the Box chassis.

Failure to follow these instructions can result in injury or equipment damage.

PCI/PCIe Card Installation

The table describes how to install a PCI/PCIe card:

Step	Action
1	Disconnect the power cord to the Box.
2	Touch the housing or ground connection (not the power supply) to discharge any electrostatic charge from your body.

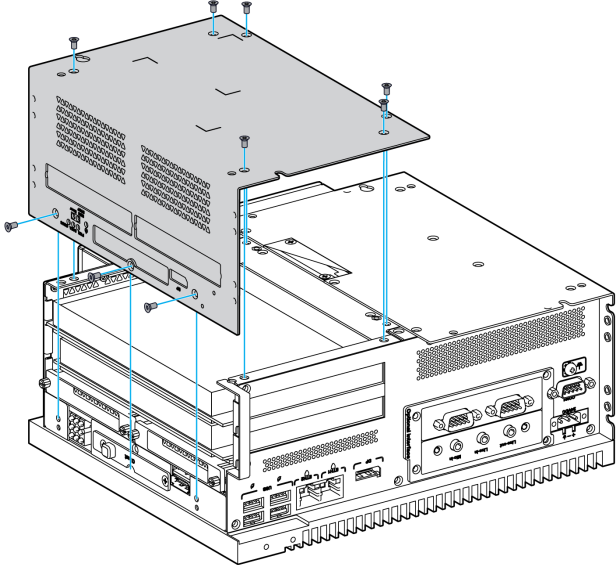
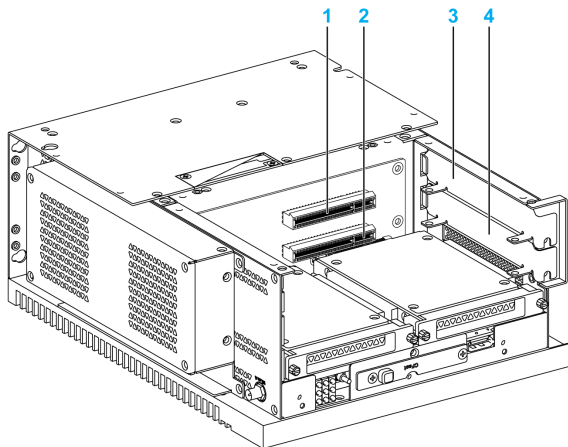
Step	Action
3	<p data-bbox="321 200 847 227">Unscrew the nine screws from the cover and remove it:</p> 
4	 <p data-bbox="321 1358 562 1464"> 1 PCI/PCIe card slot 1 2 PCI/PCIe card slot 2 3 PCI/PCIe plate slot 1 4 PCI/PCIe plate slot 2 </p> <p data-bbox="321 1485 1074 1512">NOTE: The recommended torque to tighten these screws is 0.5 Nm (4.5 lb-in).</p>

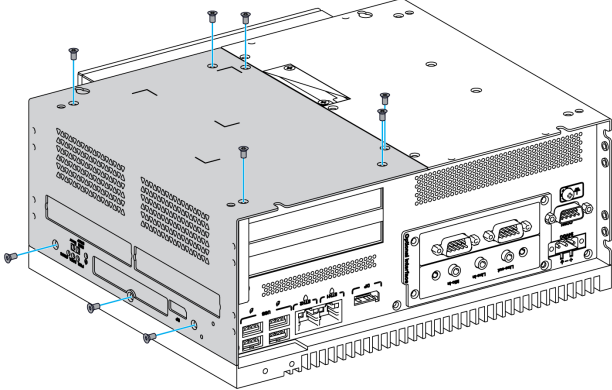
Step	Action
5	<p>Replace the cover and fasten it with nine screws:</p> 

⚠ CAUTION

OVERTORQUE AND LOOSE HARDWARE

- Do not exert more than 0.5 Nm (4.5 lb-in) of torque when tightening the installation fastener, enclosure, accessory, or terminal block screws. Tightening the screws with excessive force can damage the installation fastener.
- When fastening or removing screws, ensure they do not fall inside the Box chassis.

Failure to follow these instructions can result in injury or equipment damage.

Section 9.3

Box and Fan Kit Installation

Fan Kit Installation

Introduction

The fan kit (PFXZPBIUFAN2) is required for PCI/PCIe cards installed on board with power consumption from 3 W to 6 W maximum for two cards or 10 W maximum for one card.

The fan kit (PFXZPBIUFAN2) is mounted on the Box 2-Slot only.

Before installing a fan kit, shut down Windows in an orderly fashion and remove all power from the device.

DANGER

HAZARD OF ELECTRIC SHOCK, EXPLOSION OR ARC FLASH

- Remove all power from the device before removing any covers or elements of the system, and prior to installing or removing any accessories, hardware, or cables.
- Unplug the power cable from both the Box and the power supply.
- Always use a properly rated voltage sensing device to confirm power is off.
- Replace and secure all covers or elements of the system before applying power to the unit.
- Use only the specified voltage when operating the Box. The AC unit is designed to use 100...240 Vac input. The DC unit is designed to use 24 Vdc input. Always check whether your device is AC or DC powered before applying power.

Failure to follow these instructions will result in death or serious injury.

NOTICE

ELECTROSTATIC DISCHARGE

Take the necessary protective measures against electrostatic discharge before attempting to remove the Box cover.

Failure to follow these instructions can result in equipment damage.

Fan Kit Installation

The procedure describes how to install a fan kit:

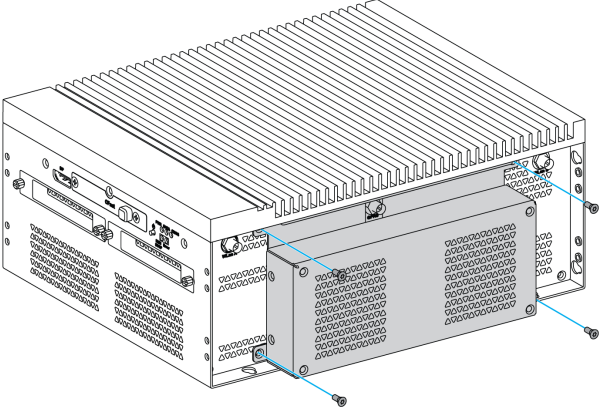
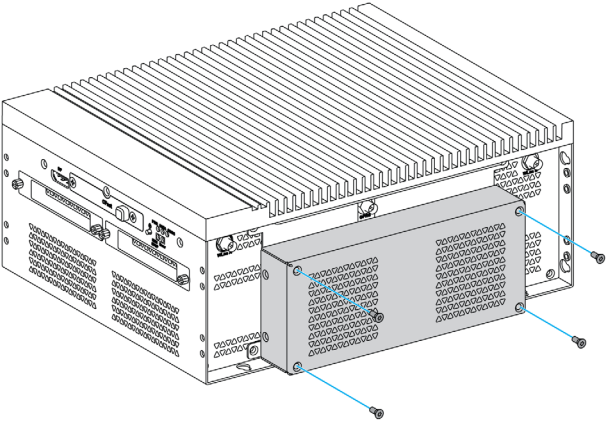
Step	Action
1	Disconnect the power supply to the Box.
2	Touch the housing or ground connection (not the power supply) to discharge any electrostatic charge from your body.
3	Remove the fan connector cover. Align the fan kit parallel to the Box and press it in until it latches. Make sure that the fan kit is inserted so that the connections match-up and fasten it with four screws supplied with the fan kit: 
4	Remove the four screws to remove the back plate and to access the filter. The filter must be regularly check: 

Section 9.4

Box and Optional Interfaces

Overview

This section describes the optional interfaces and their installation.

What Is in This Section?

This section contains the following topics:

Topic	Page
Optional Interface Installation	133
16DI/8DO Interface Module Description	139
RS-232, RS-422/485 Interface Module Description	143
Ethernet IEEE Interface Module Description	148
Ethernet PoE Interface Module Description	150
CANopen Interface Module Description	152
Profibus DP Interface Module Description	155
Audio Interface Description	157
USB Interface Module Description	158
Cellular Module	160
Transmitter for PS5000	163

Optional Interface Installation

Introduction

Before installing or removing an interface module, shut down Windows operating system in an orderly fashion and remove all power from the device.

DANGER

HAZARD OF ELECTRIC SHOCK, EXPLOSION OR ARC FLASH

- Remove all power from the device before removing any covers or elements of the system, and prior to installing or removing any accessories, hardware, or cables.
- Unplug the power cable from both the Box and the power supply.
- Always use a properly rated voltage sensing device to confirm power is off.
- Replace and secure all covers or elements of the system before applying power to the unit.
- Use only the specified voltage when operating the Box. The AC unit is designed to use 100...240 Vac input. The DC unit is designed to use 24 Vdc input. Always check whether your device is AC or DC powered before applying power.

Failure to follow these instructions will result in death or serious injury.

NOTE: The operating temperature is 0...55 °C (131 °F) except with 2 x mini PCIe + Display Module limited to 45 °C (113 °F).

Optional Interface Types

The figure shows the interface module types (top view):

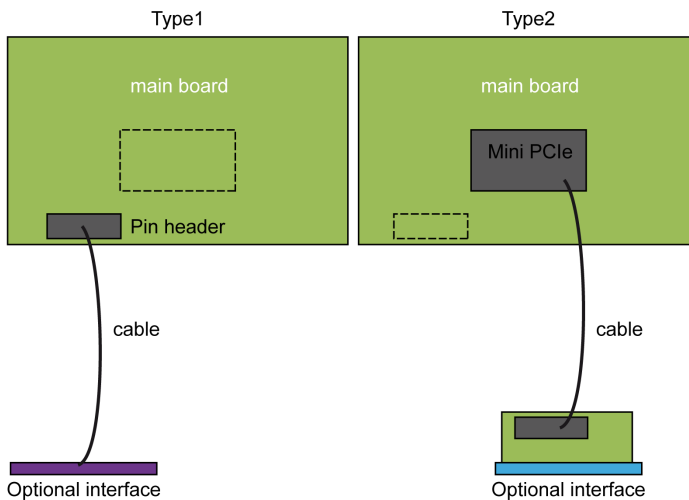

Type 1 Pin header
Type 2 mini PCIe card

The figure shows the possible interface modules:

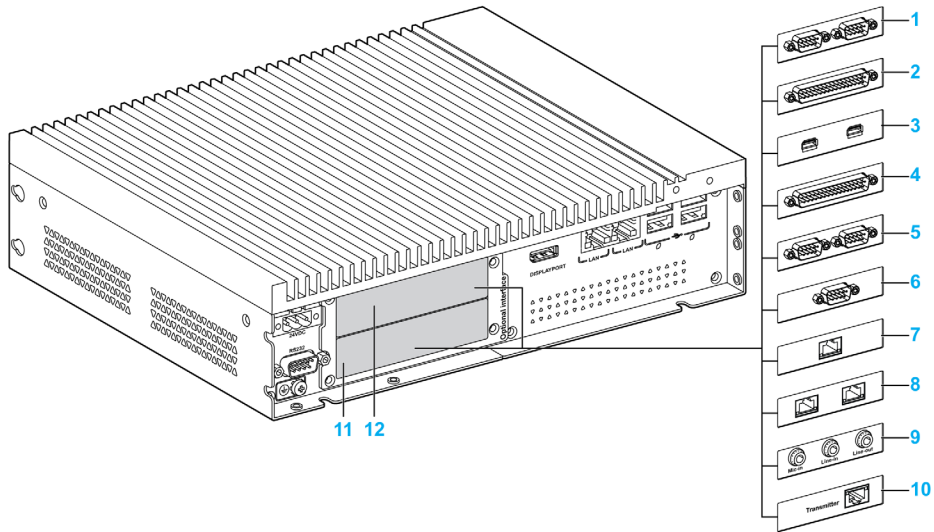

- 1 2 x RS-232, RS-422/485 interface module
- 2 4 x RS-232, RS-422/485 interface module
- 3 USB interface module
- 4 DIO interface module
- 5 CANopen interface module
- 6 Profibus DP interface module
- 7 1 x Ethernet IEEE interface module
- 8 2 x Ethernet PoE interface module
- 9 Audio interface module
- 10 Transmitter for PS5000
- 11 Optional interface 1
- 12 Optional interface 2

The table shows the type and the interface module part numbers:

Designation	Part number	Interface	mini PCIe card	Pin header	Interface plate
RS-232, RS-422/485 interface module	PFXZPBMPR42P2	2 x RS-422/485 isolated	1	–	1
	PFXZPBMPR44P2	4 x RS-422/485	1	–	1
	PFXZPBMPR22P2	2 x RS-232 isolated	1	–	1
	PFXZPBMPR24P2	4 x RS-232	1	–	1
DIO interface module	PFXZPBMPX16Y82	16 x DI / 8 x DO and 2 m cable and terminal	1	–	1
Ethernet interface module	PFXZPBMPRE2	1 x Ethernet gigabit IEEE1588	1	–	1
	PFXZPBMPPE2	2 x Ethernet gigabit PoE	1	–	1
CANopen interface module	PFXZBMPCANM2	2 x CANopen	1	–	1
Profibus DP interface module	PFXZBMPPEM2	1 x Profibus DP master with MRAM	1	–	1
USB interface module	PFXZBMPUS2P2	2 x USB 3.0	1	–	1
Audio interface module	PFXZBPHAU2	1 x Audio	–	1	1
Cellular module	PFXZBPHMC2	Cellular module: GPRS/GSM and antenna	1	–	–
Transmitter for PS5000 (see page 163)	PFXZBMPMX2	1 x RJ45	1	–	1

Interface Module Installation

Before installing or removing a mini PCIe card, shut down Windows operating system in an orderly fashion and remove all power from the device.

The Boxes PFXPP2B, PFXPU2B, PFXPP27, PFXPP2J, PFXPU27, PFXPU2J, and the Display Adapter PFXZPPDADDP2 are classified hazardous locations Class I Division 2 (see chapter "Certifications and Standards"). Observe the following:

DANGER

POTENTIAL FOR EXPLOSION

- Always confirm the ANSI/ISA 12.12.01 and CSA C22.2 N°213 hazardous location rating of your device before installing or using it in a hazardous location.
- To power on or power off a Box installed in a Class I, Division 2 hazardous location, you must either:
 - Use a switch located outside the hazardous environment, or
 - Use a switch certified for Class I, Division 1 operation inside the hazardous area.
- Do not connect or disconnect equipment unless power has been switched off or the area is known to be non-hazardous. This applies to all connections including power, ground, serial, parallel, network, and rear USB connections.
- Never use unshielded / ungrounded cables in hazardous locations.
- When enclosed, keep enclosure doors and openings closed at all times to avoid the accumulation of foreign matter inside the workstation.
- Do not use front USB and keep the cover in place.
- Do not expose to direct sunlight or UV light source.

Failure to follow these instructions will result in death or serious injury.

The Box PFXPP2L, PFXPP2N, PFXPU2L, PFXPU2N and the Display Module PFXPPD5800WP, PFXPPD5900WP are not classified hazardous locations.

⚠ DANGER

POTENTIAL FOR EXPLOSION IN HAZARDOUS LOCATION

Do not use this product in hazardous locations.

Failure to follow these instructions will result in death or serious injury.

NOTICE

ELECTROSTATIC DISCHARGE

Take the necessary protective measures against electrostatic discharge before attempting to remove the Box cover.

Failure to follow these instructions can result in equipment damage.

⚠ CAUTION

OVERTORQUE AND LOOSE HARDWARE

- Do not exert more than 0.5 Nm (4.5 lb-in) of torque when tightening the installation fastener, enclosure, accessory, or terminal block screws. Tightening the screws with excessive force can damage the installation fastener.
- When fastening or removing screws, ensure they do not fall inside the Box chassis.

Failure to follow these instructions can result in injury or equipment damage.

NOTE: Remove all power before attempting this procedure.

The table describes how to install an interface module:

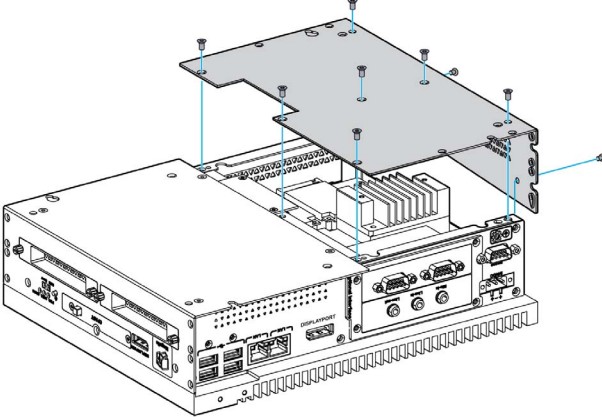
Step	Action
1	Disconnect the power cord from the Box.
2	Touch the housing or ground connection (not the power supply) to discharge any electrostatic charge from your body.
3	Unscrew the nine screws from the cover and remove it: 

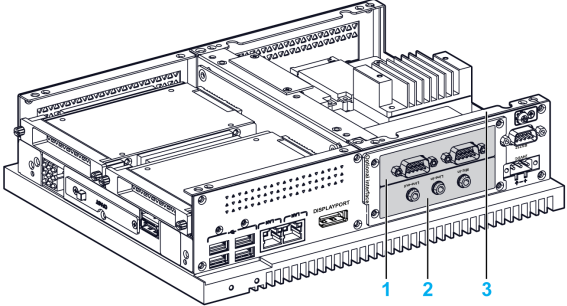
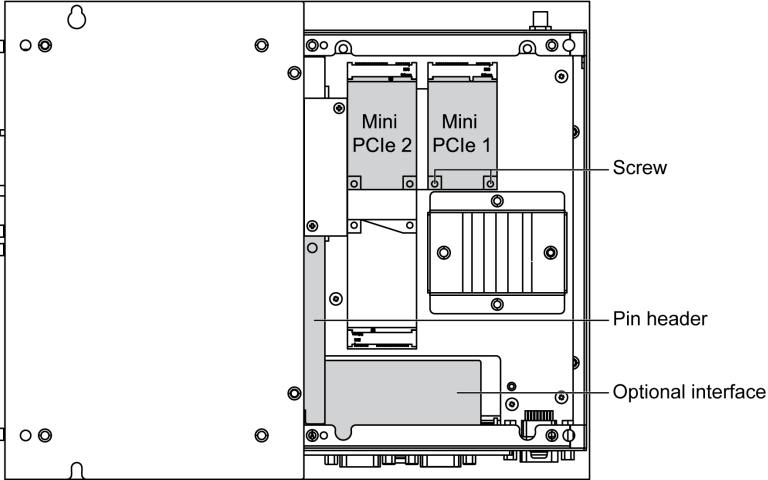
Step	Action
4	<p>Insert the interface module in the slot and fasten it to the Box with two screws:</p>  <p>1 Optional interface 1 2 Optional interface 2 3 Screw</p> <p>NOTE: The recommended torque to tighten these screws is 0.5 Nm (4.5 lb-in).</p>
5	<p>Insert the mini PCIe card into the expansion card connector and fasten it with two screws:</p>  <p>Screw Pin header Optional interface</p> <p>The pin headers are for both USB interface module and Audio interface module.</p> <p>NOTE: When using a mini PCIe card with an external cable attached, install a clamp or other device to secure the cable.</p> <p>NOTE: The requirement of Phillips screw driver is type size 2. The recommended torque to tighten these screws is 0.5 Nm (4.5 lb-in).</p>

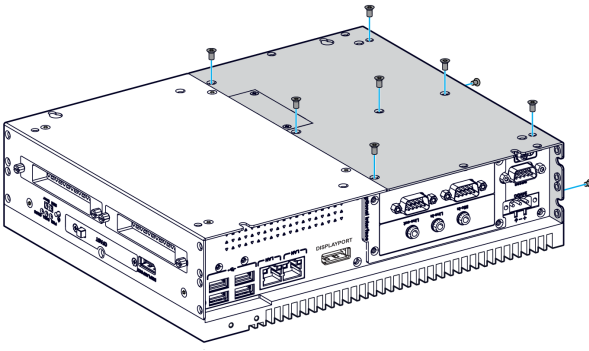
Step	Action
6	<p data-bbox="322 202 788 227">Replace the cover and fasten it with nine screws:</p>  <p data-bbox="322 627 1077 656">NOTE: The recommended torque to tighten these screws is 0.5 Nm (4.5 lb-in).</p>

16DI/8DO Interface Module Description

Introduction

The PFXZPBMPX16Y82 is categorized as a digital input/output module. It can be associated with a DIN rail terminal card, and is compatible with the mini PCIe card.

During card installation, there is no need to set jumpers or DIP switches. Instead, all bus-related configurations such as base I/O address and interrupt are automatically done by the Plug-and-Play function.

The PFXZPBMPX16Y82 has a built-in DIP switch that helps define each ID of the card when multiple 16DI/8DO interface module has been installed.

The PFXZPBMPX16Y82 offers two counter inputs which can perform event counting, frequency measurement and pulse width measurement. The counters on the interface module have a counter value match interrupt function. When this interrupt function is enabled, an interrupt signal is generated if the counter value reaches a pre-set counter match value. The counter continues to count until an overflow occurs; then it goes back to its reset value zero and continue the counting process. You can set each individual counter channel to count either falling edge (high-to-low) or rising edge (low-to-high) signals.

The figure shows the 16DI/8DO interface module:

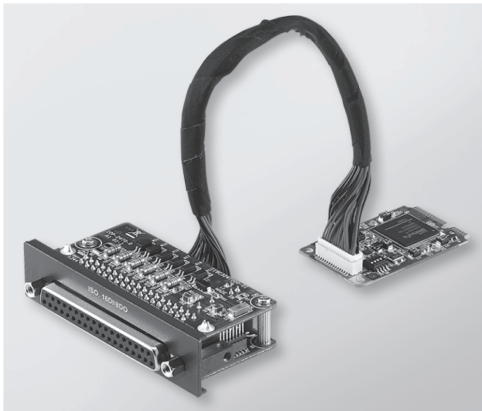

The figure shows the 16DI/16DO DIN rail terminal card and cable:



The figure shows the dimensions of the 16DI/8DO interface module:

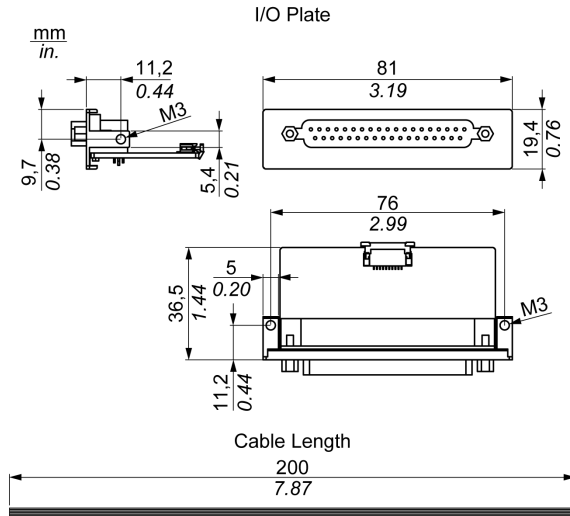

16DI/8DO Interface Module

The table shows technical data for the 16DI/8DO interface module:

Element	Characteristics
General	
Bus type	mini PCIe card revision 1.2
Connectors	1 x socket D-Sub 37-pin
Power consumption	Typical: 400 mA at 3.3 Vdc, maximum: 520 mA at 3.3 Vdc
Isolated digital input	
Input channels	16
Input voltage (wet contact)	Logic 0: 0...3 Vdc, logic 1: 10...30 Vdc
Input voltage (dry contact)	Logic 0: open, logic 1: shorted to GND
Input current	10 Vdc at 2.97 mA, 20 Vdc at 6.35 mA, 30 Vdc at 9.73 mA
Input resistance	5 KΩ
Interrupt capable channels	2, IDI0 and IDI8
Isolation protection	2,500 Vdc
Over voltage protection	70 Vdc
ESD protection	4 kV (contact) 8 kV (air)
Opto-isolator response	50 μs
Isolated digital output	
Output channels	8
Output type	MOSFET
Output voltage	5...30 Vdc
Sink current	Maximum 100 mA/channel
Isolation protection	2,500 Vdc
Opto-isolator response	50 μs

Element	Characteristics
Counter	
Channels	2
Resolution	32 bit
Maximum input frequency	1 kHz

16DI/8DO Connections

The table shows the D-Sub 37-pin assignments:

Assignment	Description	D-Sub 37-pin socket connector
IDI0...15	Isolated digital input	<p> IDI 0 / CLK0 1 IDI 2 / GATE0 IDI 4 / CLK1 IDI 6 / GATE1 IDI 8 IDI 10 IDI 12 IDI 14 ECOM0 PCOM IDO 0 IDO 2 IDO 4 IDO 6 N/C N/C N/C N/C N/C N/C N/C N/C N/C N/C N/C 20 IDI 1 IDI 3 IDI 5 IDI 7 IDI 9 IDI 11 IDI 13 IDI 15 ECOM1 EGND IDO 1 IDO 3 IDO 5 IDO 7 N/C N/C N/C N/C N/C 19 37 IDO 1 IDO 3 IDO 5 IDO 7 N/C N/C N/C N/C N/C N/C N/C </p>
IDO...7	Isolated digital output	
ECOM0	External common of IDI0...7	
ECOM1	External common of IDI8...15	
PCOM	Free wheeling common diode for IDO	
EGND	External ground	
GATE0...1	Counter gate input	
CLK0...1	Counter n clock input	
N/C	Not connected	

Switch and Jumper Settings

The jumper JP1 on the position 0 (default), load default while reset (default). The jumper JP1 on the position 1 (enabled), keeps the last status after reset.

The table shows the switch SW1 to set the ID of the 16DI/8DO interface modules:

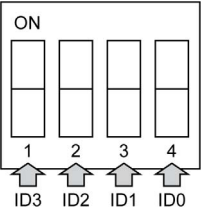
ID3	ID2	ID1	ID0	ID	Switch SW1
1	1	1	1	0	
1	1	1	0	1	
1	1	0	1	2	
1	1	0	0	3	
1	0	1	1	4	
1	0	1	0	5	
1	0	0	1	6	
1	0	0	0	7	
0	1	1	1	8	
0	1	1	0	9	
0	1	0	1	10	
0	1	0	0	11	
0	0	1	1	12	
0	0	1	0	13	
0	0	0	1	14	
0	0	0	0	15	

Device Manager and Hardware Installation

Install the driver before you install the interface module into the Box. The driver installation media for the 16DI/8DO interface module is included with the package. After the interface module is installed, you can verify whether it is properly installed on your system through the **Device Manager**

NOTE: If you see your device name listed on it but marked with an exclamation sign !, it means that your interface module has not been correctly installed. In this case, remove the device from the **Device Manager** by selecting its device name and press the **Remove** button. Then go through the driver installation process again.

After the 16DI/8DO interface module is properly installed into the Box, you can now configure your device using the navigator.

RS-232, RS-422/485 Interface Module Description

Introduction

The PFXZPBMPR series are categorized as communication modules. They are all compatible with the mini PCIe card including isolated / non-isolated RS-232, RS-422/485 communication cards for automation control.

The figure shows the RS-232, RS-422/485 interface modules:

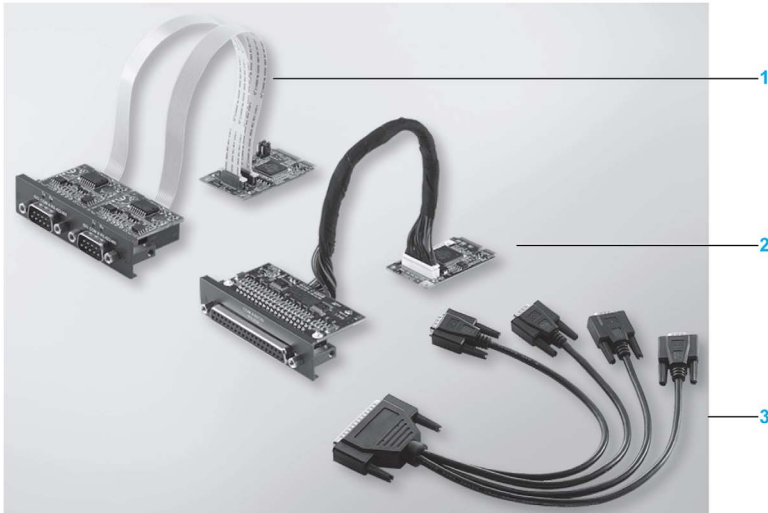

- 1 2 x RS-232, RS-422/485 interface module
- 2 4 x RS-232, RS-422/485 interface module
- 3 1 x interface cables

The following figure shows the dimensions of the 2 x RS-232, RS-422/485 interface module:

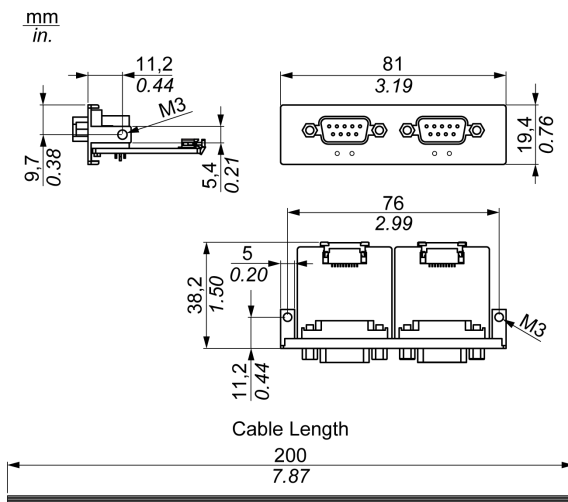

The following figure shows the dimensions of the 4 x RS-232, RS-422/485 interface module:

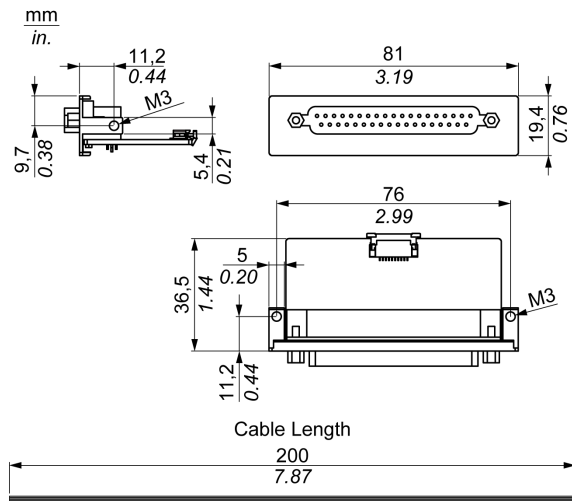

Serial Interface

The table shows technical data for the serial interfaces:

Element	Characteristics			
Part number	PFXZPBMPR42P2	PFXZPBMPR22P2	PFXZPBMPR44P2	PFXZPBMPR24P2
General				
Bus type	Mini PCIe card revision 1.2			
Type	2 x RS-422/485, electrically isolated	2 x RS-232, electrically isolated	4 x RS-422/485, electrically non-isolated	4 x RS-232, electrically non-isolated
Connectors	2 x D-Sub 9-pin, plug		1 x D-Sub 37-pin, socket	
Power consumption	3.3 Vdc at 400 mA		3.3 Vdc at 500 mA	
Communication				
Data bits	5, 6, 7, 8			
FIFO	128 bytes			
Flow control	RTS/CTS Xon/Xoff		RTS/CTS (not supported) Xon/Xoff	RTS/CTS Xon/Xoff
Parity	None, odd, even, Mark and space			
Speed	50 bps...921.6 kbps	50 bps...230.4 kbps	50 bps...921.6 kbps	50 bps...230.4 kbps
Stop bits	1, 1.5, 2			
Transfer rate				
Transfer rate RS-232	Maximum 115 kbps with cable length ≤ 10 m Maximum 64 kbps with cable length ≤ 15 m			
Transfer rate RS-422/485	Maximum 115 kbps with cable length ≤ 1200 m			

Cable Serial Interface

The table shows the technical data of the cable serial interface:

Element	Characteristics	
Signal lines	Cable cross section RS-232 Cable cross section RS-422 Cable cross section RS-485 Wire insulation Conductor resistance Stranding Shield	4 x 0.16 mm ² (26 AWG), tinned Cu. wire 4 x 0.25 mm ² (24 AWG), tinned Cu. wire 4 x 0.25 mm ² (24 AWG), tinned Cu. wire Protective earth ground ≤ 82 Ω/km Wires stranded in pairs Paired shield with aluminum foil
Grounding line	Cable cross section Wire insulation Conductor resistance	1 x 0.34 mm ² (22 AWG/19), tinned Cu. wire Protective earth ground ≤ 59 Ω/km
Outer sheathing	Material Features Cable shielding	PUR mixture Halogen free From tinned Cu. wires

Serial Interface Connections

This interface is used to connect the Box to remote equipment, via a cable. The connector is a D-Sub 9-pin plug connector.

By using a long PLC cable to connect to the Box, it is possible that the cable can be at an electrical potential that is different from the electrical potential of the panel, even if both are connected to ground.

The serial port that is not isolated has the signal ground (SG) and the functional ground terminals connected inside the panel.



ELECTRIC SHOCK

- Make a direct connection between the ground connection screw and ground.
- Do not connect other devices to ground through the ground connection screw of this device.
- Install all cables according to local codes and requirements. If local codes do not require grounding, follow a reliable guide such as the US National Electrical Code, Article 800.

Failure to follow these instructions will result in death or serious injury.

The table shows the D-Sub 9-pin assignments:

Pin	Assignment		D-Sub 9-pin plug connector:
	RS-232	RS-422/485	
1	DCD	TxD-/Data-	
2	RxD	TxD+/Data+	
3	TxD	RxD+	
4	DTR	RxD-	
5	GND	GND/VEE	
6	DSR	RTS-	
7	RTS	RTS+	
8	CTS	CTS+	
9	RI	CTS-	

The table shows the D-Sub 37-pin assignments:

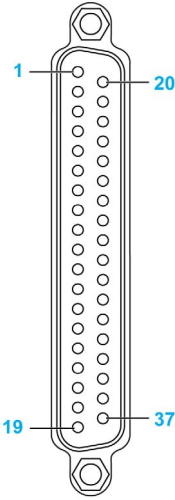
Pin	Assignment		
	RS-232	RS-422/485	
1	N.C.	N.C.	D-Sub 37-pin socket connector: 
2	DCD3	TxD3-/Data3-	
3	GND	GND/VEE3	
4	CTS3	N.C.	
5	RxD3	TxD3/Data3	
6	RI4	N.C.	
7	DTR4	RxD4-	
8	DSR4	N.C.	
9	RTS4	N.C.	
10	TxD4	RxD4	
11	DCD2	TxD2-/Data2-	
12	GND	GND	
13	CTS2	N.C.	
14	RxD2	TxD2/Data2	
15	RI1	N.C.	
16	DTR1	RxD1-	
17	DSR1	N.C.	
18	RTS1	N.C.	
19	TxD1	RxD1	
20	RI3	N.C.	
21	DTR3	RxD3-	
22	DSR3	N.C.	
23	RTS3	N.C.	
24	TxD3	RXD3	
25	DCD4	TxD4-/Data4-	
26	GND	GND/VEE4	
27	CTS4	N.C.	
28	RxD4	TxD4/Data4+	
29	RI2	N.C.	
30	DTR2	RxD2-	
31	DSR2	N.C.	
32	RTS2	N.C.	
33	TxD2	RxD2	
34	DCD1	TxD1-/Data1-	
35	GND	GND/VEE1	
36	CTS1	N.C.	
37	RxD1	TxD1/Data1+	

Any excessive weight or stress on communication cables may disconnect the equipment.

CAUTION

LOSS OF POWER

- Ensure that communication connections do not place excessive stress on the communication ports of the Box.
- Securely attach communication cables to the panel or cabinet.
- Use only D-Sub 9-pin cables with a locking system in good condition.

Failure to follow these instructions can result in injury or equipment damage.

RS-485 Interface Specificity

NOTE: All the pins of the RS-422 default interface should be used for operation.

The RTS line must be switched each time the driver is sent and received. There is no automatic switch back. This cannot be configured in Windows.

The voltage drop caused by long line lengths can lead to greater potential differences between bus stations, which can hinder communication. You can improve the communication by running a ground wire with the other wires.

NOTE: When using RS-422/485 communication with PLCs, you may need to reduce the transmission speed and increase the TX Wait time.

Device Manager and Hardware Installation

Install the driver before you install the interface module into the Box. The driver installation media is included with the package. After the interface module is installed, you can verify whether it is properly installed on your system through the **Device Manager**.

Ethernet IEEE Interface Module Description

Introduction

The PFXZPBMPRE2 is categorized as industrial communication with IEEE protocol module. It is compatible with the mini PCIe card.

The figure shows the Ethernet interface module:



The figure shows the dimensions of the Ethernet interface module:

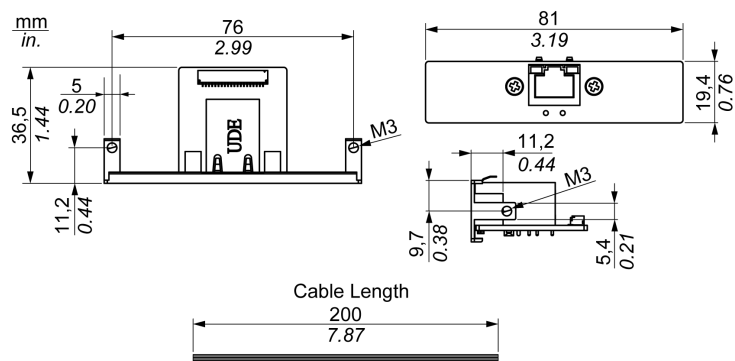

Ethernet Interface Module Description

The table shows technical data for the Ethernet interface module:

Features	Values
General	
Bus type	Mini PCIe card revision 1.2
Connectors	1 x RJ45 GbE half-/full-duplex
Power consumption	Max. 9 W at 3.3 V
Communication	
Speed	10/100/1000 base-TX, auto-negotiation
Support	9 K jumbo frames, hardware-based support for precise time synchronization over Ethernet, wake-on-LAN

Any excessive weight or stress on communication cables may disconnect the equipment.

CAUTION

LOSS OF POWER

- Ensure that communication connections do not place excessive stress on the communication ports of the Box.
- Securely attach communication cables to the panel or cabinet.

Failure to follow these instructions can result in injury or equipment damage.

Device Manager and Hardware Installation

Install the driver before you install the interface module into the Box. The driver installation media is included with the package. After the interface module is installed, you can verify whether it is properly installed on your system through the **Device Manager**.

Ethernet PoE Interface Module Description

Introduction

The PFXZPBMPPE2 is categorized as industrial communication with IEEE protocol module. The PFXZPBMPPE2 supports 2 independent 10/100/1000 base T(X) 802.3af power-over-Ethernet (PoE) compliant Ethernet ports. With 24 Vdc power input, the PFXZPBMPPE2 can boost then provides up to 2 x 15.4 watts at 48 Vdc power to maximum 2 x PoE ports on each module. It allows power to be supplied to connected devices, such as PoE-based GigE cameras in machine vision inspection systems, without the need to use separate PoE injectors for those applications. With its overload current/voltage protection on LAN ports, the PFXZPBMPPE2 is ideally designed for Gigabit Ethernet surveillance IP cameras in intelligent transportation systems, which can also benefit from a scalable Gigabit backbone construction with PoE support. It is compatible with the mini PCIe card.

The figure shows the Ethernet interface module:

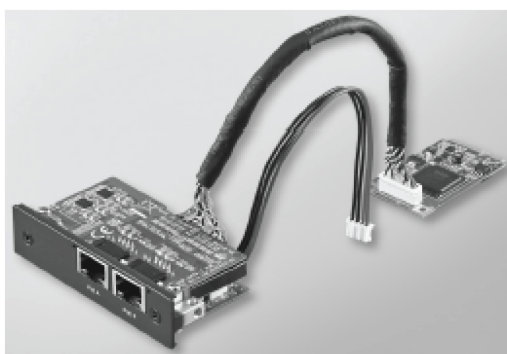

The figure shows the dimensions of the Ethernet interface module:

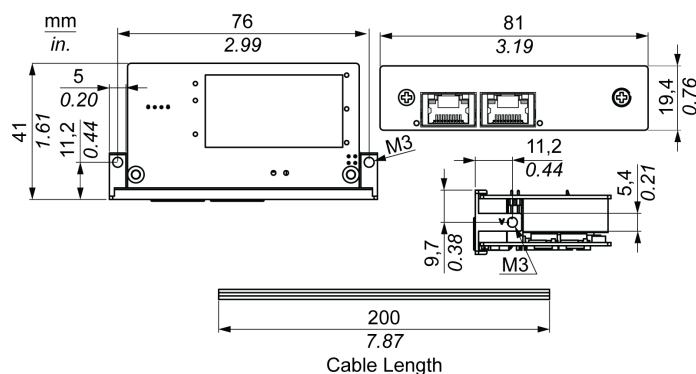

Ethernet Interface Module Description

The table shows technical data for the Ethernet interface module:

Features	Values
General	
Bus type	Mini PCIe card revision 1.2
Connectors	2 x RJ45 GbE (gigabit Ethernet) half-duplex/full-duplex
Port	2 x Gigabit Ethernet media access control (MAC) and physical layer (PHY) ports.

Features	Values
Compatibility	IEEE 802.3, IEEE 802.3u, IEEE 802.3ab, IEEE 802.3x, IEEE 802.3af.
Output PoE	48 Vdc Supports 2 PoE ports up to 2 x 15.4 W at 48 Vdc
Communication	
Speed	10/100/1000 base-TX, auto-negotiation

Any excessive weight or stress on communication cables may disconnect the equipment.

CAUTION

LOSS OF POWER

- Ensure that communication connections do not place excessive stress on the communication ports of the Box.
- Securely attach communication cables to the panel or cabinet.

Failure to follow these instructions can result in injury or equipment damage.

Device Manager and Hardware Installation

Install the driver before you install the interface module into the Box. The driver installation media is included with the package. After the interface module is installed, you can verify whether it is properly installed on your system through the **Device Manager**.

CANopen Interface Module Description

Introduction

The PFXZPBMPCANM2 is categorized as industrial communication with fieldbus protocol modules. It is compatible with the mini PCIe card.

The figure shows the CANopen interface module:

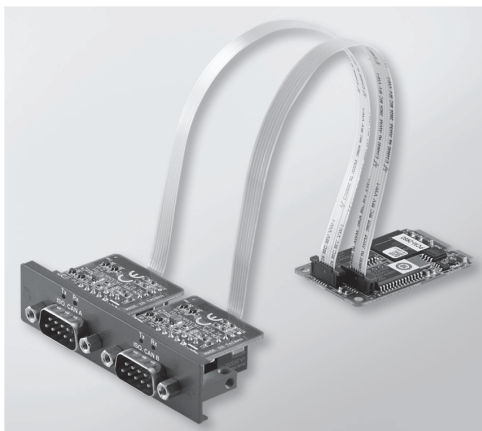

The figure shows the dimensions of the CANopen interface module:

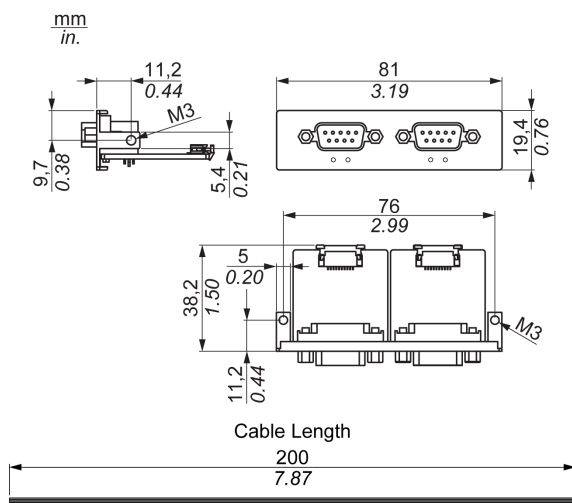

CANopen Interface Module Description

The table shows technical data for the CANopen interface module:

Features	Values
General	
Bus type	Mini PCIe card revision 1.2
Connector	2 x plug D-Sub 9-pin
Power consumption	400 mA at 5 Vdc
Communication	

Features	Values
Protocol	CAN 2.0 A/B
Signal support	CAN_H, CAN_L
Speed	1 Mbit/s
CAN frequency	16 MHz
Termination resistor	120 Ω (selected by jumper)

Connections

This interface is used to connect the Box to remote equipment, via a cable. The connector is a D-Sub 9-pin plug connector.

By using a long PLC cable to connect to the Box, it is possible that the cable can be at an electrical potential that is different from the electrical potential of the panel, even if both are connected to ground.

The table shows the D-Sub 9-pin assignments:

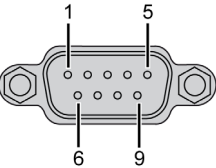
Pin	Assignment	D-Sub 9-pin plug male connector
1	–	
2	CAN_L	
3	GND	
4	–	
5	–	
6	–	
7	CAN_H	
8	–	
9	–	

NOTE: You can set the terminator resistor by jumper setting. The position (pin 1-2) is for the value of the terminator resistor of 120 ohm. The position (pin 2-3) is for without terminator resistor.

Any excessive weight or stress on communication cables may disconnect the equipment.

CAUTION

LOSS OF POWER

- Ensure that communication connections do not place excessive stress on the communication ports of the Box.
- Securely attach communication cables to the panel or cabinet.
- Use only D-Sub 9-pin cables with a locking system in good condition.

Failure to follow these instructions can result in injury or equipment damage.

Device Manager and Hardware Installation

Install the driver before you install the interface module into the Box. The driver installation media for the CANopen interface module is included with the package. After the interface module is installed, you can verify whether it is properly installed on your system through the **Device Manager**

NOTE: If you see your device name listed on it but marked with an exclamation sign !, it means that your interface module has not been correctly installed. In this case, remove the device from the **Device Manager** by selecting its device name and press the **Remove** button. Then go through the driver installation process again.

After the CANopen interface module is properly installed into the Box, you can now configure your device using the navigator.

The CANopen Protocol Library provides a C application programming interface (API) for accessing the CANopen network protocol stack of nodes. It is easy to use, configure, start, and monitor the CANopen devices carelessly CAN bus, developer focused on CANopen application functionality:

- Read and write object dictionary (local or by SDO)
- Control or monitor the node NMT state (NMT master)
- PDO transmission mode: on request, by SYNC, time driven, event driven
- Support 512 TPDOs and 512 RPDOs
- SYNC producer and consumer
- Heartbeat producer and consumer
- Emergency objects

Profibus DP Interface Module Description

Introduction

The PFXZPBMPPBM2 is categorized as industrial communication with fieldbus protocol modules (Profibus DP master or slave). It is compatible with the mini PCIe card.

NOTE: Download the firmware and configuration. Use the corresponding master or slave DTM in the configuration software SYCON.net (HILSCHER CIFX 90E-DP\ET\FMR\ADVA/+ML).

The figure shows the Profibus DP interface module:



Profibus DP Interface Module Description

The table shows technical data for the Profibus DP interface module:

Features	Values
General	
Bus type	mini PCIe card revision 1.2
Connector	1 x socket D-Sub 9-pin
Memory	8 Mb SDRAM / 4 Mb serial flash EPROM
Size of the dual-port memory	64 Kbyte
Power consumption	600 mA at 3.3 Vdc
Communication	
Protocol	Profibus DP V1
Signal support	RxD/TxD-P, RxD/TxD-N
Transmission rate	33 MHz
Dimensions	60 x 45 x 9.5 mm (2.36 x 1.77 x 0.37 in)

Profibus DP Specification

The table shows the Profibus DP specification:

Features	Profibus DP slave	Profibus DP master
Slave max.	–	125
Cyclic data max.	244 bytes	244 bytes/slave
Acyclic read/write	6,240 bytes	
Maximum number of modules	24	–
Configuration data	244 bytes	244 bytes/slave
Parameter data	237 bytes	

NOTE: To configure the master, a GSD file (device description file) is required. The settings in the used master must comply with the settings in the slave to establish communication. The main parameters are: Station address, ID number, baudrate, and config data (the configuration data for the output and input length).

Connections

This interface is used to connect Box to remote equipment, via a cable. The connector is a D-Sub 9-pin plug connector.

If you use a long PLC cable to connect to the Box, the cable can be at an electrical potential that is different from the electrical potential of the panel, even if both are connected to ground.

The table shows the D-Sub 9-pin assignments:

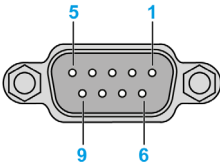
Pin	Assignment	Description	D-Sub 9-pin plug female connector
1	–	–	
2	–	–	
3	RxD/TxD-P	Receive/Send Data-P connection B plug	
4	–	–	
5	GND	Reference potential	
6	VP	Positive supply voltage	
7	–	–	
8	RxD/TxD-N	Receive/Send Data-N connection A plug	
9	–	–	

Any excessive weight or stress on communication cables may disconnect the equipment.

⚠ CAUTION
LOSS OF POWER
<ul style="list-style-type: none"> ● Ensure that communication connections do not place excessive stress on the communication ports of the Box. ● Securely attach communication cables to the panel or cabinet. ● Use only D-Sub 9-pin cables with a locking system in good condition.
Failure to follow these instructions can result in injury or equipment damage.

Device Manager and Hardware Installation

Install the driver before you install the interface module into the Box. The driver installation media is included with the package. After the interface module is installed, you can verify whether it is properly installed on your system through the **Device Manager**.

Audio Interface Description

Introduction

The PFXZPBPHAU2 is categorized as an audio interface (line in, line out, Mic in). The audio interface module is composed of an audio I/O board (include metal plate) and a cable for connecting I/O board and the Box.

The figure shows the audio interface module:

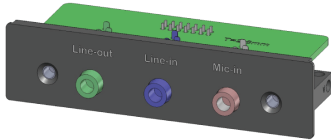

The figure shows the dimensions of the audio interface cable:

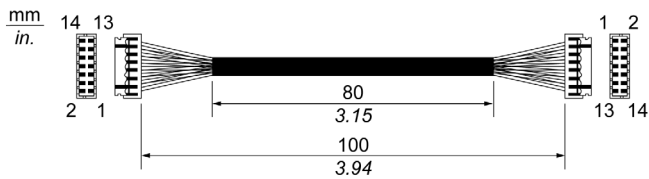

Audio Interface

The table shows technical data for the audio interface:

Element	Characteristics
Connectors	line in, line out, mic in
Audio output type	stereo

USB Interface Module Description

Introduction

The PFXZPBMPUS2P2 are categorized as communication modules. It is all compatible with the mini PCIe card.

The figure shows the USB interface module:



The figure shows the dimensions of the USB interface module:

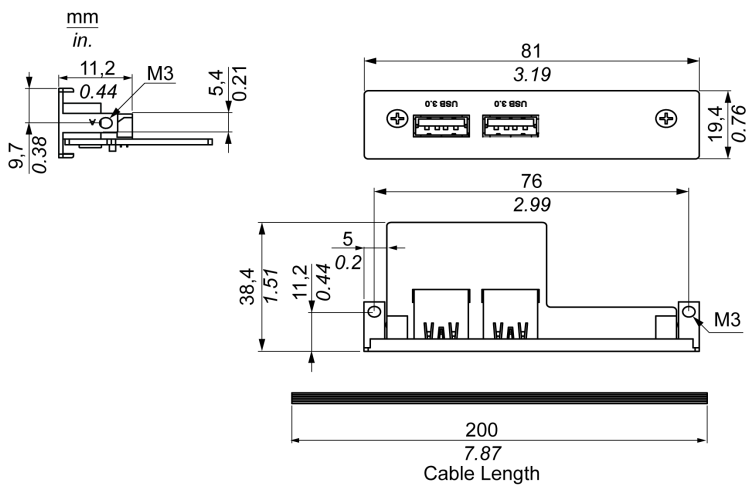

USB Interface Module

The table shows technical data for the USB interface module:

Element	Characteristics
General	
Bus type	Mini PCIe card revision 1.2
Connector	2 x ports USB 3.0
Power consumption	+5 Vdc / 900 mA power output to USB device (typical: 3.3 Vdc)
Communication	
Protocol	Universal serial Bus 3.0 specification Rev. 1.0
Speed	Low speed: 1.5 Mbit/s, full speed: 12 Mbit/s, high speed: 480 Mbit/s, super speed: 5 Gbit/s

Device Manager and Hardware Installation

Install the driver before you install the interface module into the Box. The driver installation media is included with the package. After the interface module is installed, you can verify whether it is properly installed on your system through the **Device Manager**.

Cellular Module

Introduction

The PFXZPBPHMC2 is categorized as a GPRS (general packet radio service). It provides a cost effective solution for wireless remote connection to distributed installations over the Internet. It is compatible with the mini PCIe card with SIM card holder.

GPRS is a packet-oriented data service based on GSM (global system for mobile). It offers the advantages to pay only for the total volume of data exchanged (in MB per month) regardless of the connection time while data communication via traditional circuit switching (PSTN/GSM) is charged per minute of connection time.

GSM connections are used for on-demand services such as sending SMS alarms or basic remote services such as diagnostics.

GPRS is more suitable for permanent access to remote installations providing:

- Easy remote programming.
- Continuous remote monitoring and control.
- Transparent routing capabilities from the Internet to LAN networks or serial network devices connected to the Box gateway.

In addition, GPRS provides higher data exchange rates than GSM:

	Upload	Download
Theoretical	24 kbps	48 kbps
Typical	16 kbps	20 kbps

NOTE: These values depend on your service provider, the distance between your Cellular module and the base station, and the current traffic.

NOTE: If too many browsers are being used on a modem connection (GPRS, PSTN), performance may decrease and lead to difficulties with page refreshing.

The figure shows the Cellular module:

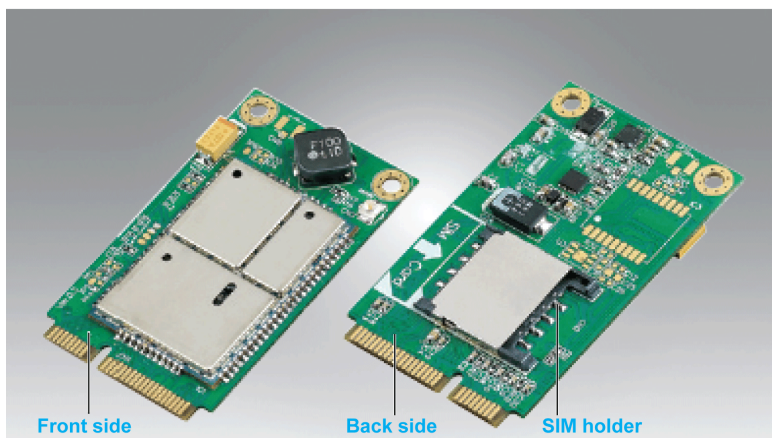

Cellular Module Description

The table shows technical data for the Cellular module:

Features	Values
General	
Bus type	mini PCIe card revision 1.2
Connector	1 x RF antenna coaxial connectors
Power consumption	3.3...3.6 Vdc < 700 mA (HSPA connected mode)
Peak current	1.5 A
Communication	
Protocol	UMTS/HSPA network: 800/850/900/1700/1900/2100 MHz EDGE/ GPRS/ GSM network: 850/ 900/ 1800/ 1900 MHz
Speed	Downlink: 7.2 Mbit/s (HSDPA) / uplink: 5.76 Mbit/s (HSUPA)
Dimensions (l x w x h)	50.85 x 29.9 x 6.2 mm (2.0 x 1.17 x 0.24 in)

Any excessive weight or stress on communication cables may disconnect the equipment.

⚠ CAUTION

LOSS OF POWER

- Ensure that communication connections do not place excessive stress on the communication ports of the Box.
- Securely attach communication cables to the panel or cabinet.
- Use only D-Sub 9-pin cables with a locking system in good condition.

Failure to follow these instructions can result in injury or equipment damage.

GPRS Remote Access

GPRS communication implies:

- The Cellular module is connected to the Internet via the GPRS network.
- The remote PC or network is also connected to the Internet.

GPRS topologies can support:

- NAT (network address translation) routing tables for transparent routing to Ethernet devices
- security services such as IP address control or VPN tunnels for secured data exchange over the Internet

The following figure shows remote access to the network of the Cellular module:

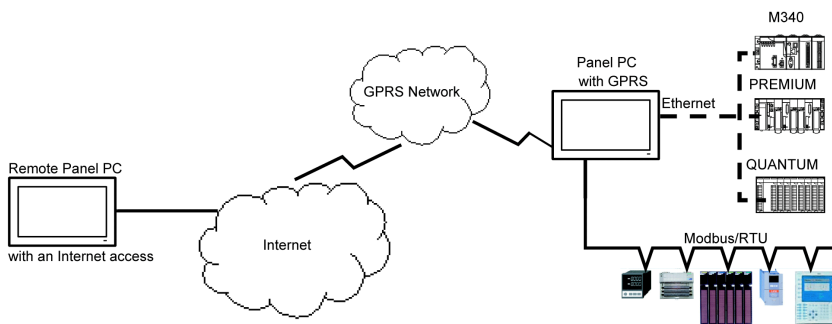

Connection Principles

GPRS communication requires a SIM card and a specific GPRS contract with a service provider. The GPRS connection is always initiated from the module to the GPRS network.

It is not possible for a client application to open a connection by directly dialing the Cellular module. Nevertheless, the Cellular module provides various solutions to connect to the GPRS network:

Permanent mode:

- Automatic connection at startup, restart or after connection loss.

On-demand mode:

- Callback function: opens the connection upon receiving an incoming GSM or PSTN call.
- Autonomously on a process or application condition.

The Cellular module connects the APN (*access point name*) of the service provider and receives an IP address back that can be static or dynamic.

The Cellular module supports both static and dynamic IP addresses. If the address is dynamic, it is necessary to inform the remote application of the new IP address.

NOTE:

- GPRS uses the DNS server of the service provider; it replaces the DNS server configured in the Box.
- The default gateway set in the Ethernet configuration of the Box is not used with a GPRS connection. The default route of the GPRS connection is used instead. Thus, it is not possible to route through Ethernet when the module is connected to the GPRS network.

GPRS Contracts

GPRS service providers offer dedicated services adapted to industrial applications, also called M2M (*machine to machine*).

Service providers offer GPRS contracts with different options. The main options are:

- Public or private IP address: Choose a contract that gives you a public IP address to be accessible directly from the Internet.
- Static or dynamic IP address.
- Incoming TCP ports blocked or not: Some providers offer only subscriptions with TCP ports blocked for security reasons. For example, some provider block ports that are lower than 1024.

NOTE:

- For ease of use and configuration, you should choose a contract that does not block TCP ports and provides a static IP address.
- If your service provider blocks the public ports (< 1024), you must use a VPN and choose a contract that authorizes VPN traffic.

Device Manager and Hardware Installation

Install the driver before you install the interface module into the Box. The driver installation media is included with the package. After the interface module is installed, you can verify whether it is properly installed on your system through the **Device Manager**.

Transmitter for PS5000

Introduction

The PFXZPBMPX2 is categorized as industrial communication with HDBaseT protocol module. It is compatible with the mini PCIe card.

The figure shows the Transmitter for PS5000:

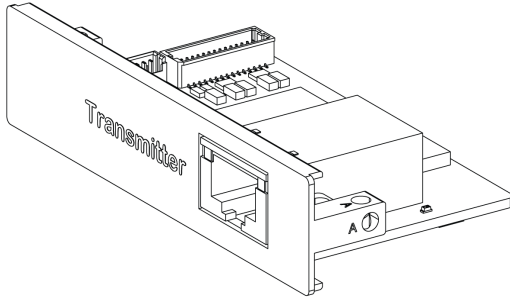

The figure shows connections of the Transmitter for PS5000:

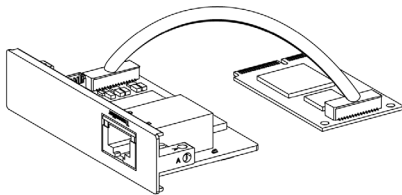

The figure shows the dimensions of the Transmitter for PS5000:

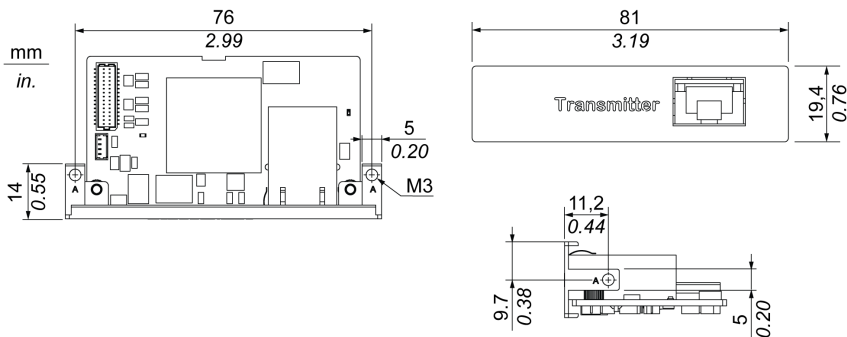

Transmitter for PS5000 Description

The table shows technical data for the Transmitter for PS5000:

Features	Values
General	
Bus type	mini PCIe card revision 1.2
Connectors	RJ45 port x1
Power consumption	Max. 3.3 W
Optional temperature	0...45 °C (113 °F)

Features	Values
Communication	
Graphic support	Support 2D
Output interface	HDBaseT
Output resolution	1920 x 1080
Point to point transmit distance	100 m (328 ft)
Cable	CAT6

Any excessive weight or stress on communication cables may disconnect the equipment.

 CAUTION
LOSS OF POWER <ul style="list-style-type: none">● Ensure that communication connections do not place excessive stress on the communication ports of the Box.● Securely attach communication cables to the panel or cabinet. Failure to follow these instructions can result in injury or equipment damage.

Device Manager and Hardware Installation

Install the driver before you install the interface module into the Box. The driver installation media is included with the package. After the interface module is installed, you can verify whether it is properly installed on your system through the **Device Manager**.

Chapter 10

System Monitor

Subject of this Chapter

This chapter describes the system monitor features of the Box.

What Is in This Chapter?

This chapter contains the following topics:

Topic	Page
System Monitor Interface	166
Device Management - Monitoring Rules	171
Account Setting - System Setting	189

System Monitor Interface

Overview

The **System Monitor** 3.0 interface provides remote monitoring, a feature that helps you access multiple clients through a single console for remote device management. The **System Monitor** immediately recognizes equipment and provides real-time equipment maintenance, which improves system stability and reliability.

Remote Monitoring monitors system status of remote devices. The monitored items include hard disk temperature, hard drive health, network connection, CPU temperature, system voltages, system fan status, and UPS status.

Remote Monitoring also provides support for function logs so that managers can regularly check the status of their remote devices.

The **System Monitor** sends notification and makes an entry in the event log.

NOTE: When configuring the **System Monitor**, it is not possible to create a group/device as the virtual keyboard is not accessible from configuration. The work-around consists of plugging in a physical keyboard.

System Monitor Requirements

The table describes the software requirements:

Description	Software
Framework	Microsoft.NET Framework version 3.5 or higher
Driver	Software 4.0 API

System Monitor Console

The **System Monitor** console acts as a server for the clients. Devices that run on the **System Monitor** console display the health and status information from the **System Monitor** clients. The console has to be made available by the clients over a network.

Launch the system tray of **ServerControl** from Windows **Start** → **Programs** and right-click to launch **ServerControl** menu from tray icon:

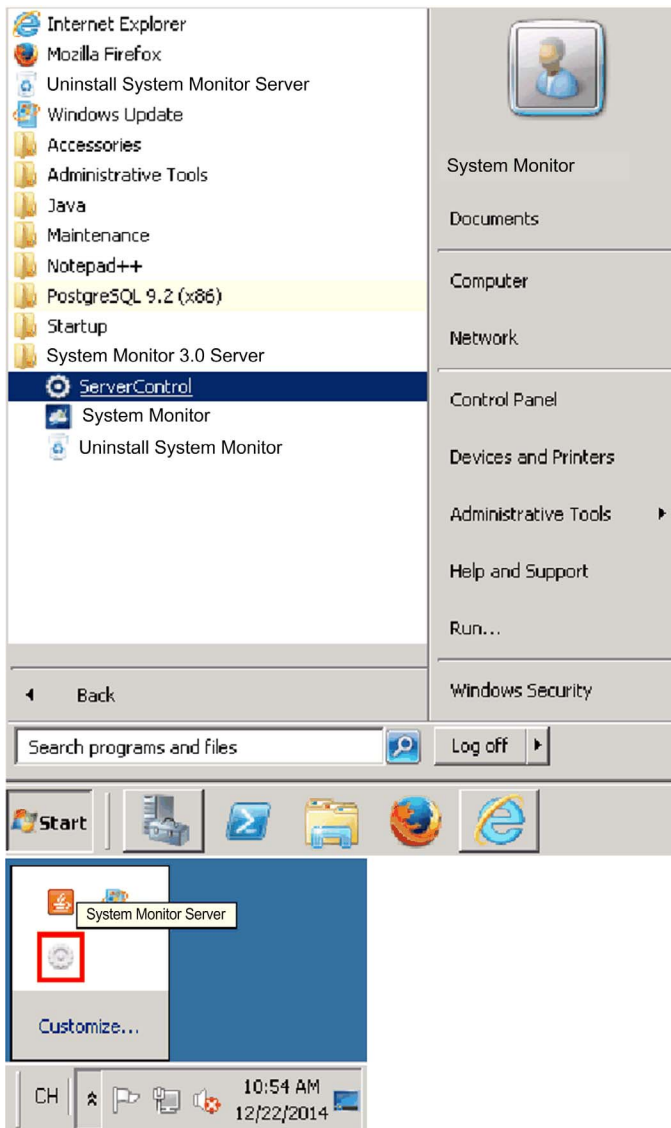

Click **Management Service** to start/stop main **System Monitor** management service:

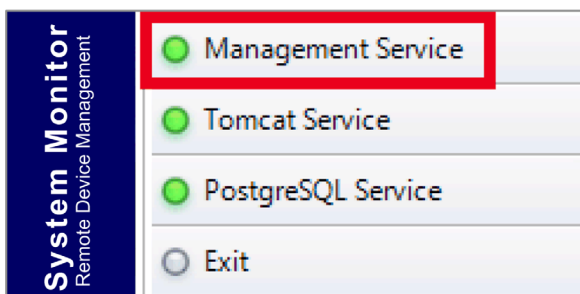

Tomcat Service

Tomcat is an open-source Web server and servlet container. Tomcat implements several Java EE specifications including Java servlet, JavaServer pages (JSP), Java EL, and WebSocket, and provides a Java HTTP Web server environment for Java code to run in.

Click **Tomcat Service** to start/stop **System Monitor** Web service:

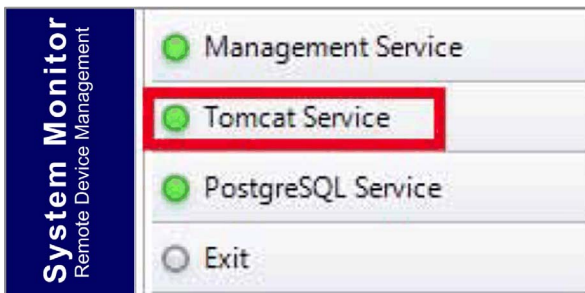

PostgreSQL Service

PostgreSQL is an object-relational database management system (ORDBMS). As a database server, its function is to store data and retrieve it later, as requested by other software applications running on another computer across a network and the Internet. It can handle workloads ranging large internet-facing applications with many concurrent users. PostgreSQL provides replication of the database itself for availability and scalability.

Click **PostgreSQL Service** to start/stop **System Monitor** database service:

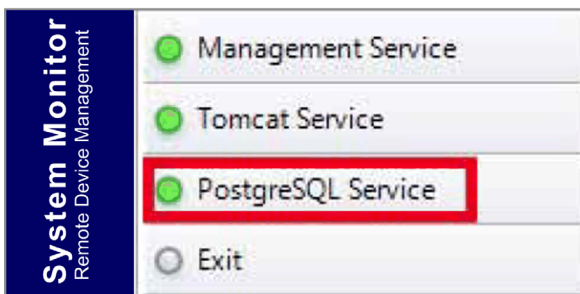

Exit

Click **Exit** to terminate server management console from tray icon and all **System Monitor** services are still running in the background. You can restart console from Windows/Programs menu:

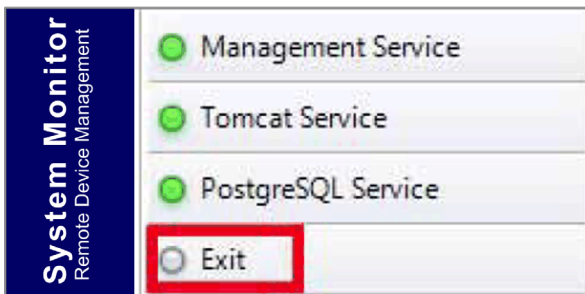

Remote Manage Devices Any Time, Any Where

System Monitor is a **Console-Server-Agent** web-based structure for cloud management. Agent here refers to Box devices, and server refers to the server directly in contact with the agent. The server can be a physical entity located in a central control room, or a virtual host set up in a cloud. Console refers to a web-based interface that connects to the server and communicates with the agent through the server. Administrators can perform equipment status and maintenance checks on **System Monitor** console through an Internet browser at any time, from anywhere, using any connected device. The server-agent connection fit the MQTT communication protocol. This improves connection security and stability, and also decreases development time for **System Monitor** integration. The console-server-agent web-based structure not only lowers the difficulty of setting up **System Monitor** network environments when provisioning, but also provides a distributed connectivity structure that solves the challenges encountered with large-scale or multi-site device management. **System Monitor** is a real-time management platform that breaks geographical limitations. Administrators can manage all of their devices by simply using their PCs, smartphones, and tablets.

NOTE: MQTT (formerly message queue telemetry transport) is a publish-subscribe based messaging protocol for use on top of the TCP/IP protocol.

Power Management

Select the action from drop-down menu of each device/group list item to power off, reboot and hibernate device.

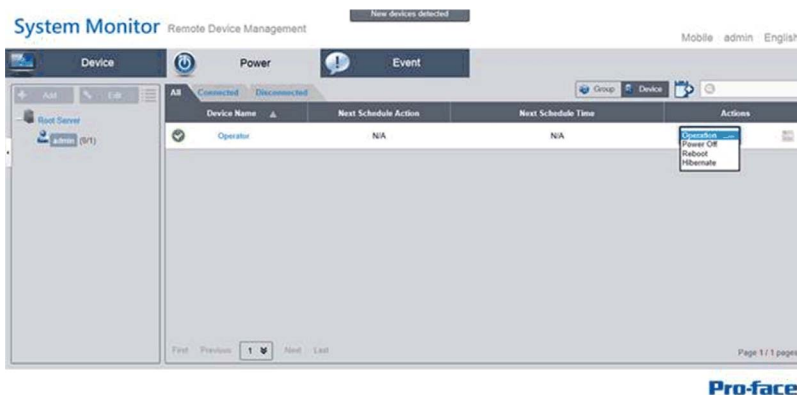

Seamless HW/SW Monitoring for Complete Protection

In order to ensure device stability, **System Monitor** actively monitors device temperatures, voltages, and the states of hard disks and other hardware. In addition to hardware monitoring functions, **System Monitor** has a software monitoring function to oversee program status. Active alerts are sent out if any abnormalities are observed, and **System Monitor** can execute related actions according to user settings, like stopping or restarting processes, which further ensure normal device operation. **System Monitor** provides a comprehensive, seamless, device monitor and control system that includes both hardware and software.

KVM Feature

The **System Monitor** features a remote KVM (keyboard, video, and mouse) and allow remote diagnosis and recovery in any situation. The time saving on trouble shooting with real-time remote monitoring and proactive alarm notifications ensure continued system health.



User-Friendly Map-View Interface

Taking advantage of web-based features, **System Monitor** provides map-view interface and leverages Google and Baidu maps to help administrators locate and manage their devices more easily. In addition to the maps, **System Monitor** also provides for building diagrams to help pinpoint device locations in offices, factories, or wherever. **System Monitor** provides a user-friendly interface in an overall easy-to-use environment.

NOTE: Baidu maps or Beidu maps is a Chinese online mapping service.

System Monitor Client (Desktop)

This procedure describes the User Login/Logout interface:

Step	Description
1	<p>The System Monitor supports mainstream browsers like Chrome, Firefox, Internet Explorer and Safari. The portal page supports multi-language and auto-detects the language currently used by browsers for default displaying. You can select the language from the menu at top-right corner to change manually:</p>  <p>User Log In</p> <ul style="list-style-type: none"> You can input valid user name, password, and click Login to verify and enter main management page (by default the user is <code>admin</code> and password <code>admin</code>). Check Auto Login to allow users to cache login information and auto login each time. <p>NOTE: For security concerns, do not check this option if you are using a public PC.</p> <p>If you forget your password, click Forgot Password. Put the registered user email in the prompt dialog after it has auto resent the password to your email.</p>
2	<p>Changing Password for First log in: For the first successful login, new user can change their password or bypass it:</p> 
3	<p>User Log Out Click User Log Out from the right corner menu to check out the system.</p>

Device Management - Monitoring Rules

Device Management

This procedure describes how to use the **Device Management** user interface:

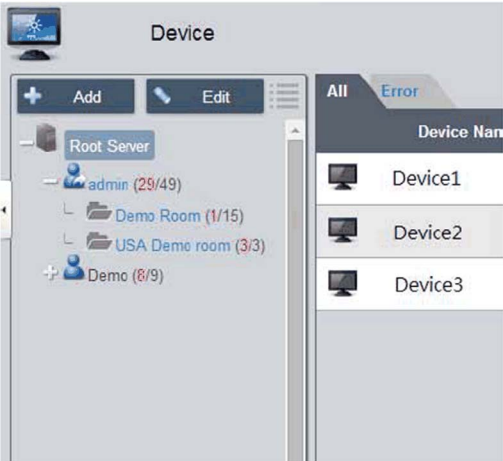
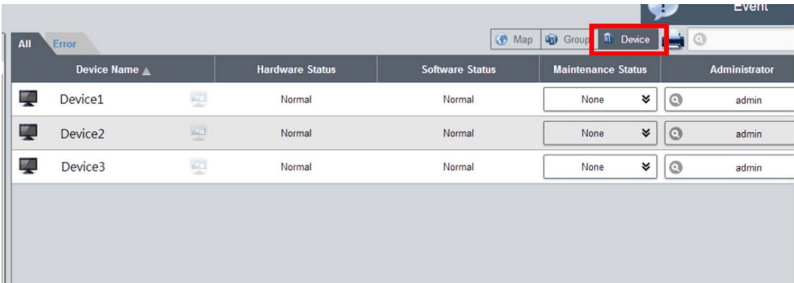
Step	Description																				
<p>1</p>	<p>Device management</p> <ul style="list-style-type: none"> • After user login, Device is the default page. • Device management page is composed of a system hierarchy tree (left-side) and device list (right-side). • Device management provides three levels of management view: Device List, Group List, and Map View. • System hierarchy tree includes server, account, and group node for device/group list mode as well as location, layout, and device node for map view mode. Each node supports corresponding operations (add/delete/edit) according to node attributes.  <p>The screenshot shows the 'Device' management page. On the left, there is a system hierarchy tree under 'Root Server' with nodes for 'admin (29/49)', 'Demo Room (1/15)', 'USA Demo room (3/3)', and 'Demo (8/9)'. On the right, there is a device list with columns for 'Device Name' and 'Device' (represented by icons). The list contains 'Device1', 'Device2', and 'Device3'. Above the list, there are tabs for 'All' and 'Error'.</p>																				
<p>2</p>	<p>View mode – Device status list:</p>  <p>The screenshot shows the 'Device' status list view. At the top, there are tabs for 'Map', 'Group', and 'Device' (which is highlighted with a red box). Below the tabs is a table with the following columns: 'Device Name', 'Hardware Status', 'Software Status', 'Maintenance Status', and 'Administrator'. The table contains three rows of data:</p> <table border="1"> <thead> <tr> <th>Device Name</th> <th>Hardware Status</th> <th>Software Status</th> <th>Maintenance Status</th> <th>Administrator</th> </tr> </thead> <tbody> <tr> <td>Device1</td> <td>Normal</td> <td>Normal</td> <td>None</td> <td>admin</td> </tr> <tr> <td>Device2</td> <td>Normal</td> <td>Normal</td> <td>None</td> <td>admin</td> </tr> <tr> <td>Device3</td> <td>Normal</td> <td>Normal</td> <td>None</td> <td>admin</td> </tr> </tbody> </table>	Device Name	Hardware Status	Software Status	Maintenance Status	Administrator	Device1	Normal	Normal	None	admin	Device2	Normal	Normal	None	admin	Device3	Normal	Normal	None	admin
Device Name	Hardware Status	Software Status	Maintenance Status	Administrator																	
Device1	Normal	Normal	None	admin																	
Device2	Normal	Normal	None	admin																	
Device3	Normal	Normal	None	admin																	

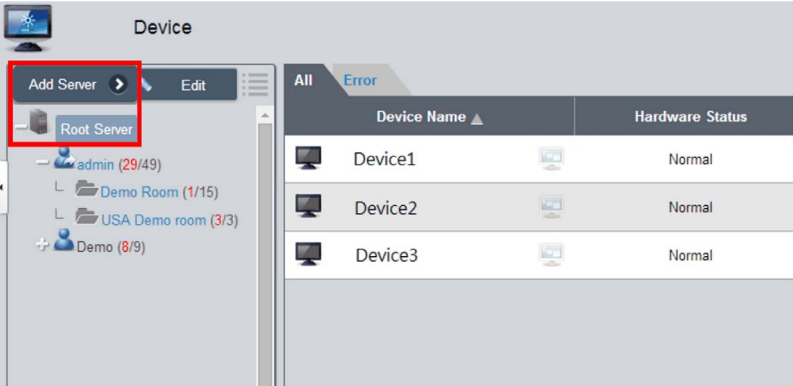
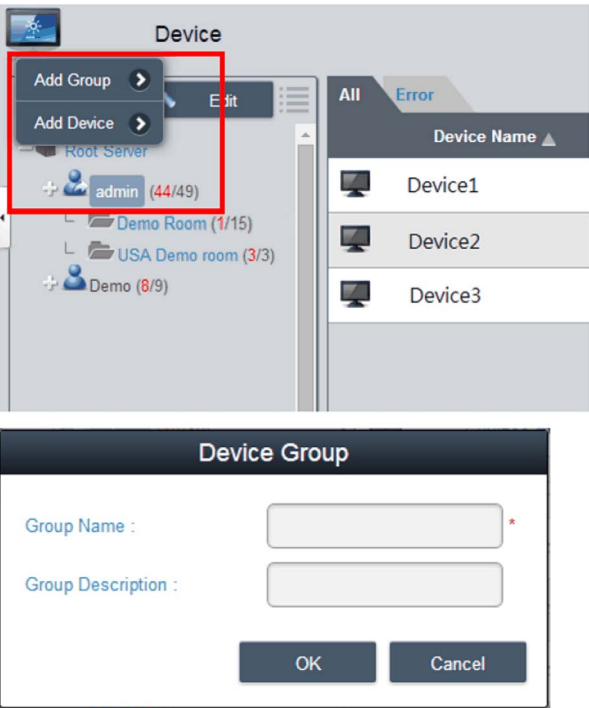
Step	Description
3	<p>Add/Delete/Edit device server Add device server: Select on one of server nodes and click Add to the pop up menu option:</p>  <p>Click Add Server to pop up the Device Server dialog for new subserver registering.</p> <p>Delete device server: Click Edit to switch to edit mode and click the icon X to delete this server node.</p> <p>Edit device server: Click Edit to switch to edit mode and select one of the server nodes. You can remove and edit this server node.</p>
4	<p>Add/Delete/Edit device group Add device group: Select one user account and click Add to the pop up menu option. Click Add Group to pop up Device Group dialog for new group addition:</p> 

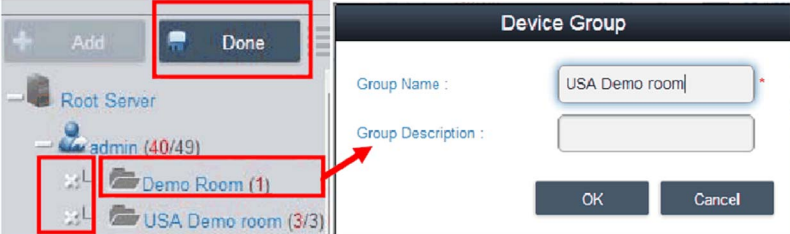
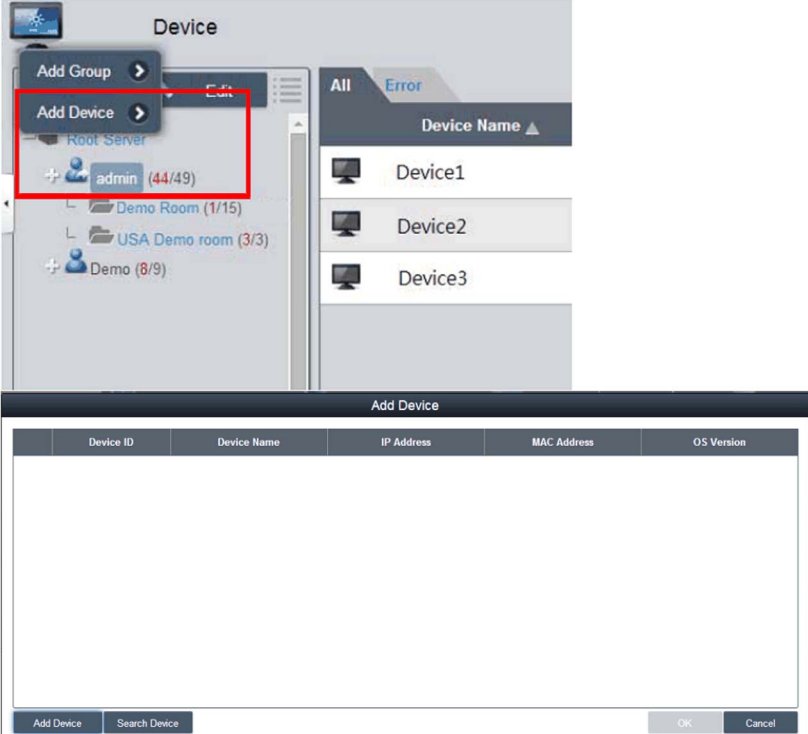
Step	Description
<p>5</p>	<p>Delete /Edit device group Delete /Edit device group: Click Edit to switch to edit mode and select one of the group nodes. You can remove and edit this group node:</p> 
<p>6</p>	<p>Add/Delete/Edit device Add device: Select one of the user accounts or groups and click Add to the pop up menu option. Click Add Device to the pop up dialog for new device addition:</p> 

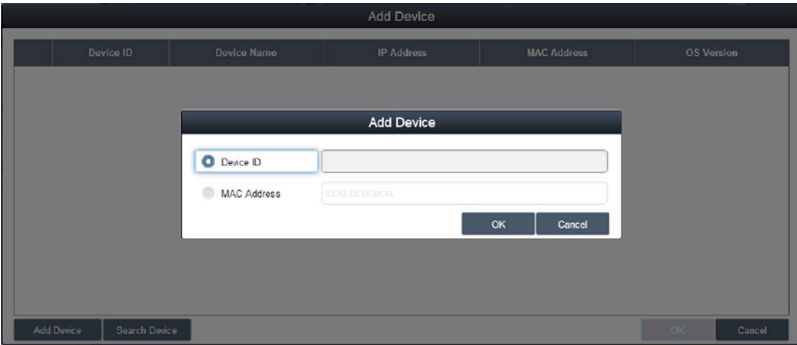
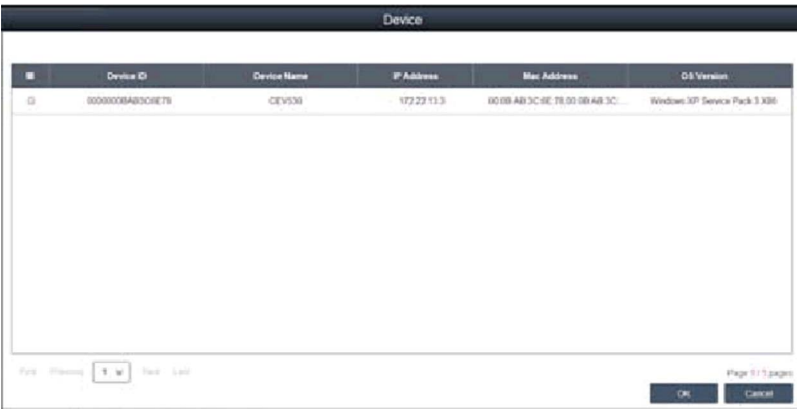
Step	Description
7	<p>Manual add</p> <p>Click Add Device to pop up the Add Device dialog to add a device manually. You can input known device ID or MAC addresses that have already registered to the server and assign a current account or group. If the device does not exist, you can also add a device directly:</p> 
8	<p>Search device</p> <p>Click Search Device to pop up the Device dialog for advanced device smart search. The system auto-discovers both connected and unassigned devices located at the same local area network as the client user:</p> 

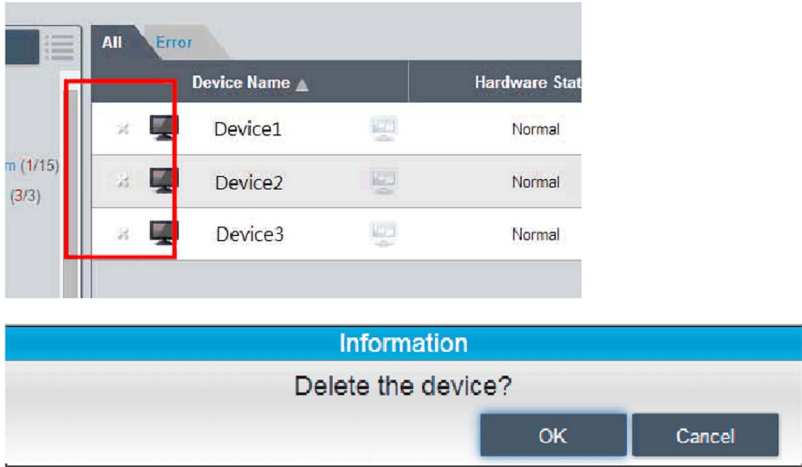
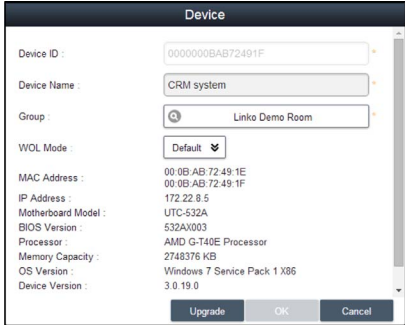
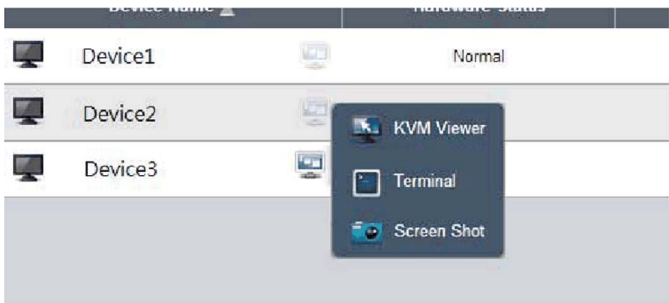
Step	Description
9	<p>Delete device</p> <p>Click Edit to switch to edit mode. You can remove and edit devices on the device list in this mode. Click the X icon for the selected device row and confirm the device warning removal:</p> 
10	<p>Edit device</p> <p>Click Edit to switch to edit mode. You can remove and edit devices of the device list in this mode. Click selected device name to pop up the Device dialog for editing:</p> 
11	<p>Remote control – KVM viewer</p> <p>When a device has been connected, the remote control icon shows on the right side of the device name. Click the icon for advanced controls including KVM (Keyboard Video Mouse) viewer, terminal, and screen shot:</p> 

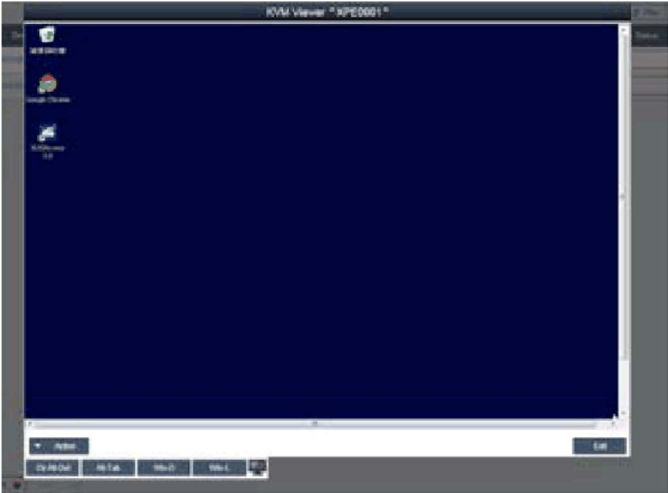
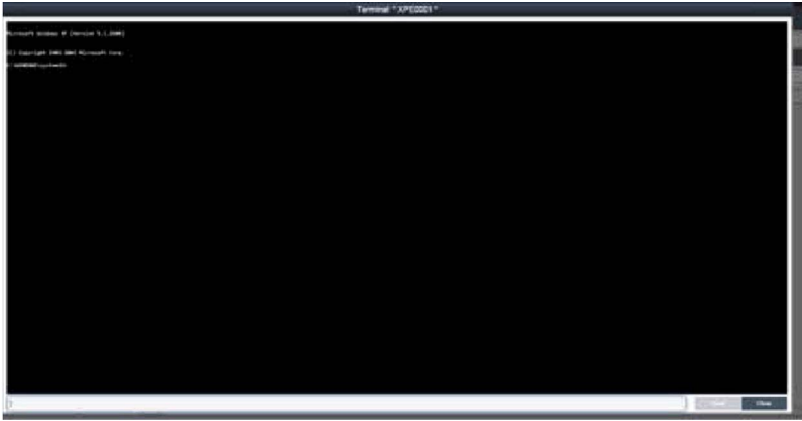
Step	Description
12	<p data-bbox="294 202 412 227">KVM viewer</p> <p data-bbox="294 229 1103 255">Click the icon from the remote control menu to connect to the device for KVM control:</p>  <p data-bbox="294 794 1204 871">NOTE: you can select KVM connection method on the device agent side. System default is System Monitoring KVM (Ultra VNC), you can select other already-installed VNC, or disable this function for security concerns.</p>
13	<p data-bbox="294 884 550 909">Remote control – Terminal</p> <p data-bbox="294 911 1199 964">Click the icon from the remote control menu to connect to the device for terminal command-line control:</p> 

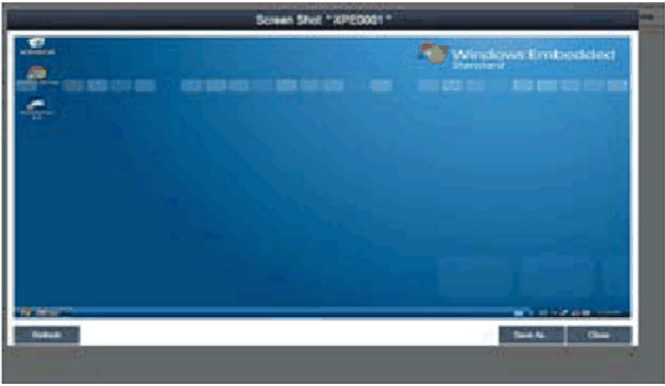
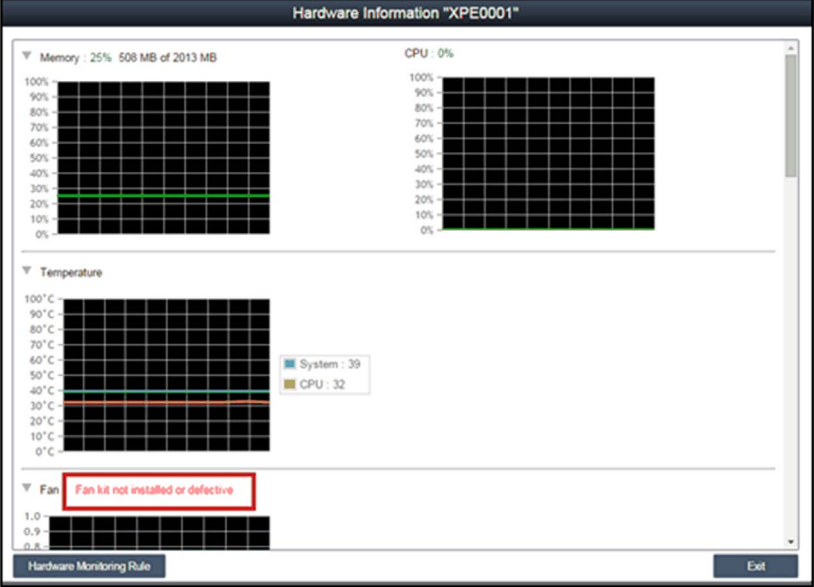
Step	Description
14	<p>Remote control – Screen shot</p> <p>Click the icon from the remote control menu to snapshot the desktop screen of the remote device and save it on the local client side:</p> 
15	<p>Hardware monitoring status</p> <p>Real-time monitoring chart: Click the field Hardware Status of the device list item to display graphically hardware real-time parameters (memory, CPU usage, temperature and HDD health status). Click the parameter name to disable/enable displaying of the parameter curve:</p> 

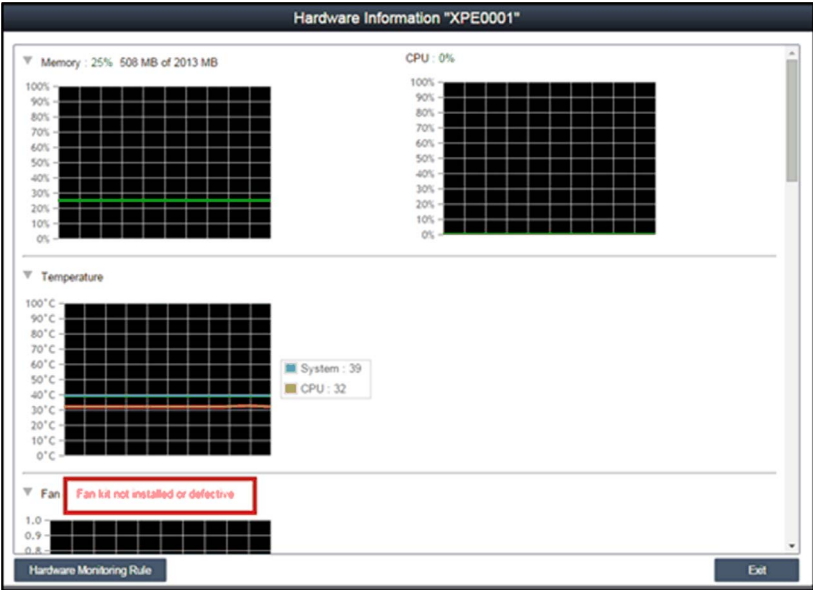
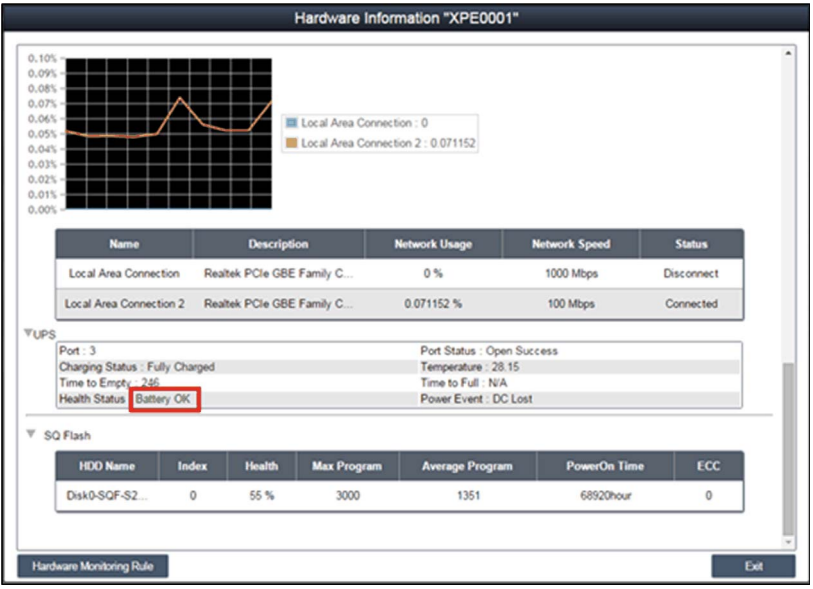
Step	Description
<p>16</p>	<p>Hardware monitoring fan status If the fan kit is not installed or the fan rpm is 0 a message will notify: fan kit not installed or defective. To get notification about status of the system fan you need to set the appropriate rules, see step Hardware monitoring rules:</p> 
<p>17</p>	<p>Hardware monitoring UPS health status If the UPS kit is installed a message will notify the health status of the battery: fHealth status of the battery : Battery OK : Green color. To get notification about status of the system fan you need to set the appropriate rules, see next step:</p> 

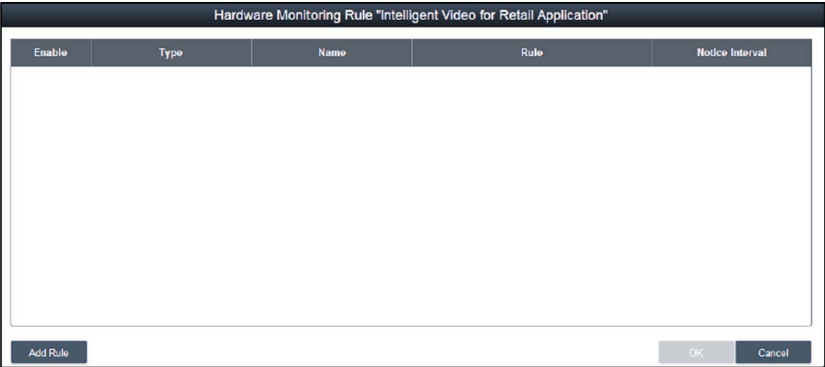
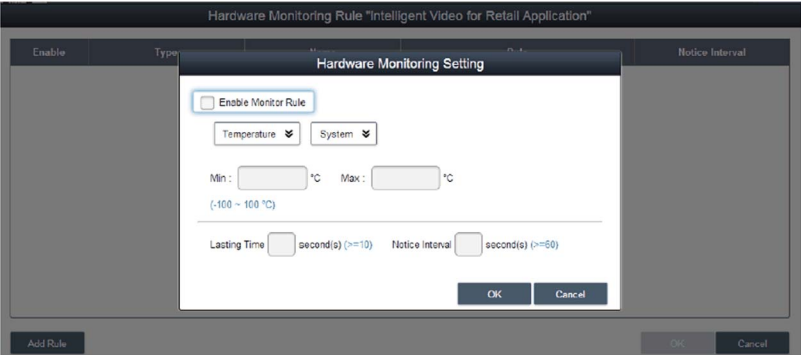
Step	Description
18	<p>Hardware monitoring rules</p> <p>Click the button Hardware Monitoring Rule to pop up the hardware monitoring dialog. The dialog lists current monitoring rules for hardware parameters includes CPU, voltage, HDD, and so on:</p> 
19	<p>Add rules</p> <p>Click the button Add Rules button to add a new rule for hardware monitoring. You can select the type of monitoring hardware from the menu, input threshold values for the corresponding parameter, the last time in seconds for reaching that threshold and a notice interval for 2 contiguous events. Before clicking OK, you can check the option Enable Monitor Rule to enable/disable this new rule:</p> 

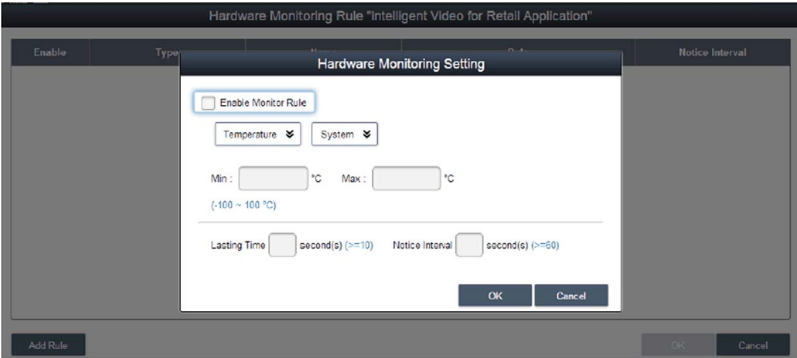
Step	Description
20	<p>Edit rules</p> <p>Click a row in the Hardware Monitoring Rule box to pop up the Hardware Monitoring Setting dialog box:</p>  <p>Delete rules: Click the X icon on the left side of the schedule item to delete the schedule.</p> <p>Enable/Disable schedule: Check the enable check box in the schedule row to enable/disable the schedule.</p>

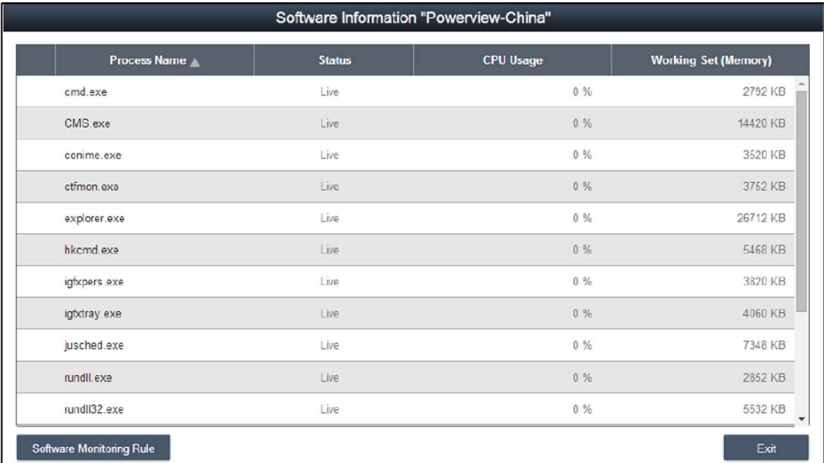
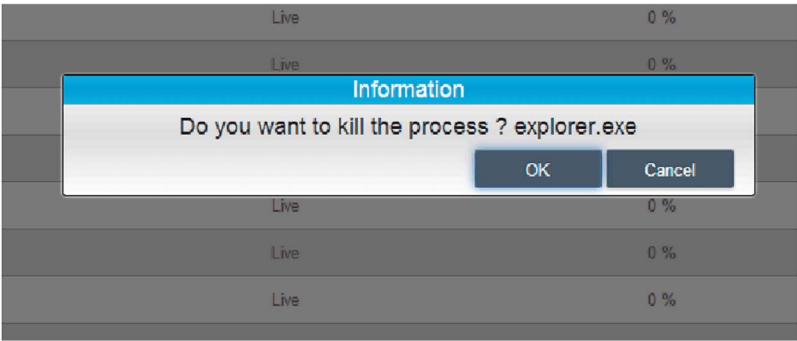
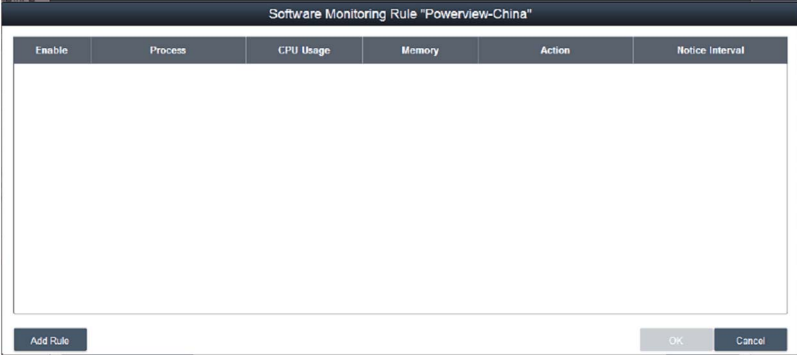
Step	Description
21	<p>Software monitoring status Real-time process list: Click the Software Status field in the device list to display the status list for active real-time software (name, status, CPU usage, and memory):</p>  <p>Click the process name to pop up the confirm dialog for killing a specified process, after confirming, you can kill and force the process to terminate:</p> 
22	<p>Software monitoring rules Click the button Software Monitoring Rules to pop up the dialog for set software monitoring rule. The dialog lists current monitoring rules for software processes:</p> 

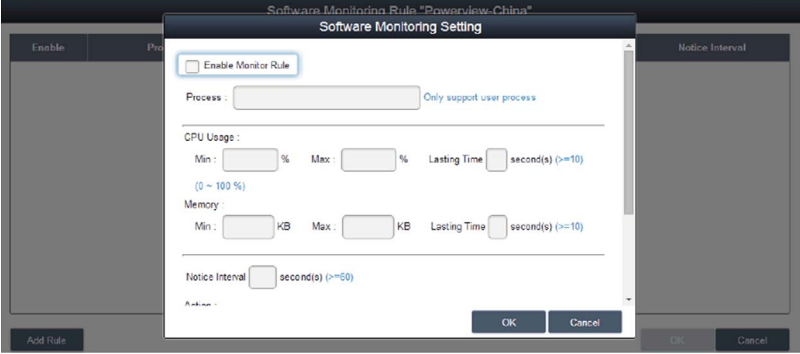
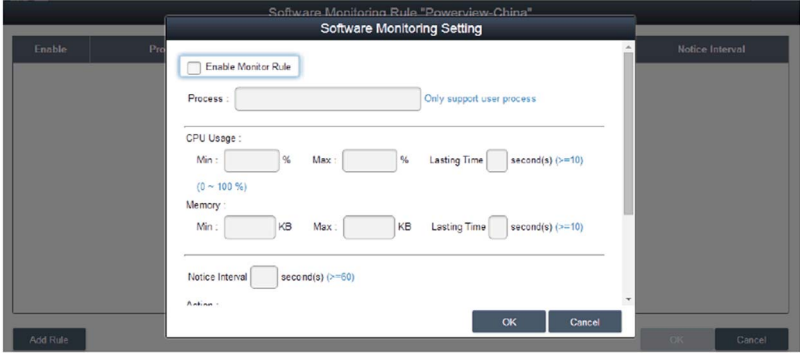
Step	Description
23	<p>Add rules</p> <p>Click the button Add Rules to add a new rule for software monitoring. You can input the process name that they want to monitor, the threshold values of the CPU and memory, the last time in seconds for reaching the threshold, and the notice interval for 2 contiguous events and corresponding action. Before clicking the OK button to add the rule, you can check the option Enable Monitor Rule to enable/disable this new added rule:</p>  <p>NOTE: The software monitoring can only monitor and execute actions for the user process.</p>
24	<p>Edit rules</p> <p>Click one of the fields to pop up the Software Monitoring Setting dialog for editing:</p>  <p>Delete rules: Click the icon X on the left side of the schedule item to delete the schedule.</p> <p>Enable/Disable schedule: Check the enable check box in the schedule row to enable/disable the schedule.</p>

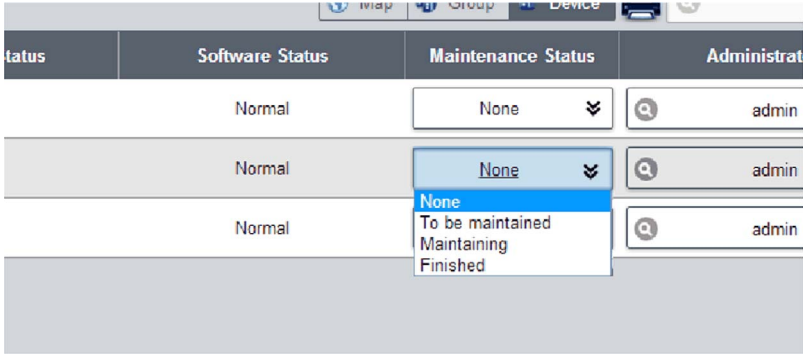
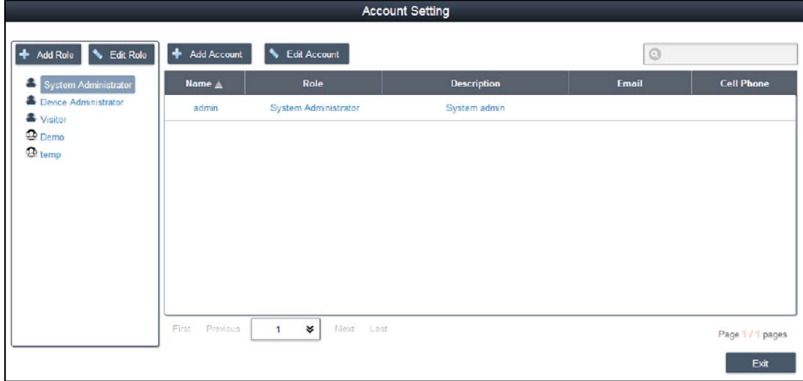
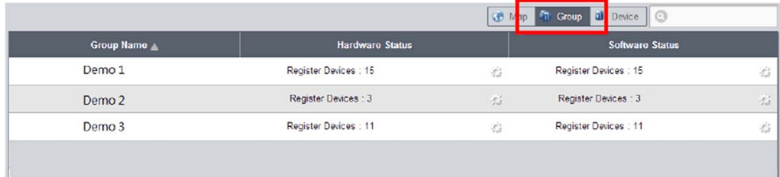

Step	Description
<p>25</p>	<p>Maintenance status You can change the maintenance status (none / to be maintained / maintaining / finished) from the menu for each device:</p> 
<p>26</p>	<p>Devices administrator Users with device management permissions can click the Admin field to pop up the selection dialog for administrator to reassign device administrator status to another account:</p> 
<p>27</p>	<p>View mode - Group status list Click the Group tab to list groups under the selected account or group node. The group list shows all group names, group hardware status, and group software status:</p>  <p>Group hardware status: This field shows the number of all registered devices and abnormal hardware devices under this group.</p> <p>Group software status: This field shows the number of all registered devices and abnormal software devices under this group.</p>

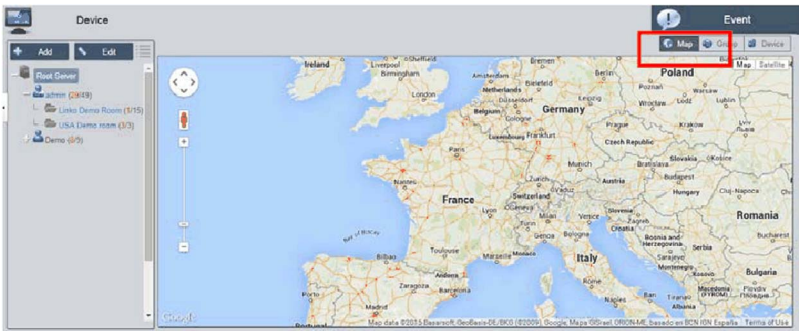

Group Hardware and Software Monitoring Rules

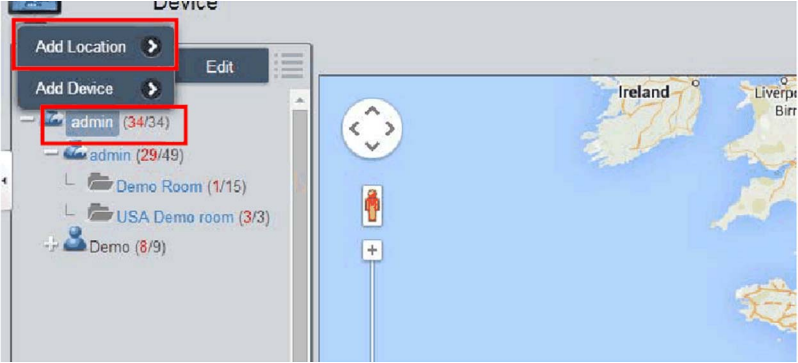
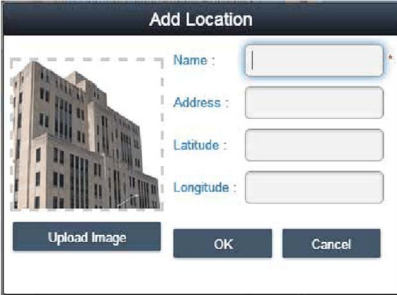
This procedure describes how to use the **Group Hardware and Software Monitoring Rules** user interface:

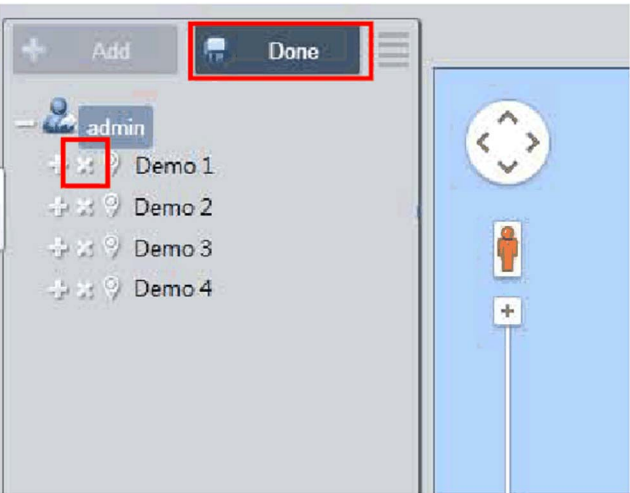
Step	Description
1	<p>Group hardware monitoring rules</p> <p>Click the icon on the right to pop up the dialog Set Hardware Monitoring Rule. The dialog lists current monitoring rules and parameters of each group's devices including CPU, voltage, HDD, and so on.</p> <p>Add group rules:</p> <p>Click the Add Rule button to add a new rule for hardware monitoring. You can select the type of monitoring hardware from the menu, input threshold values of corresponding parameter, last time in seconds of reaching the threshold, and notice interval for 2 contiguous events. Before clicking OK to add the rule, you can check the option Enable Monitor Rule to enable/disable this new rule.</p> <p>Edit group rules:</p> <p>Click the rule field to pop up the Hardware Monitoring Setting dialog for editing.</p> <p>Delete rules:</p> <p>Click the X icon on the left side of the scheduled item row to delete the schedule. Enable/Disable schedule.</p> <p>Click the enable check box in the row item to enable/disable the schedule.</p>
2	<p>Group software monitoring rules</p> <p>Click the icon in the field of group hardware status to pop up the Set Software Monitoring Rule dialog box. The dialog lists current monitoring rules for software processes of group devices.</p> <p>Add group rules:</p> <p>Click the button Add Rule to add a new rule for software monitoring. You can input the process name that wants to monitor, the threshold values of CPU and memory, the last time of reaching threshold, notice interval of 2 contiguous events and corresponding action when the monitoring rule is applied. Before clicking the button OK to add rule, you can check the option Enable Monitor Rule to enable/disable this new added rule.</p> <p>Edit group rules:</p> <p>Click the rule field to pop up the Software Monitoring Setting dialog for editing.</p> <p>Delete rules:</p> <p>Click the X icon on the left side of the scheduled item row to delete the schedule.</p> <p>Enable/Disable schedule:</p> <p>Click the enable check box in the row item to enable/disable the schedule</p>
3	<p>View mode - Device map view</p> <p>Device Map View visualizes each physical device's location, separate user interface as left-side map hierarchy tree includes account, location, layout, and device node and right-side geography view includes online map and static image map. Different tree node support corresponding add, delete, and edit operations and intuitive drag device nodes as well:</p> 

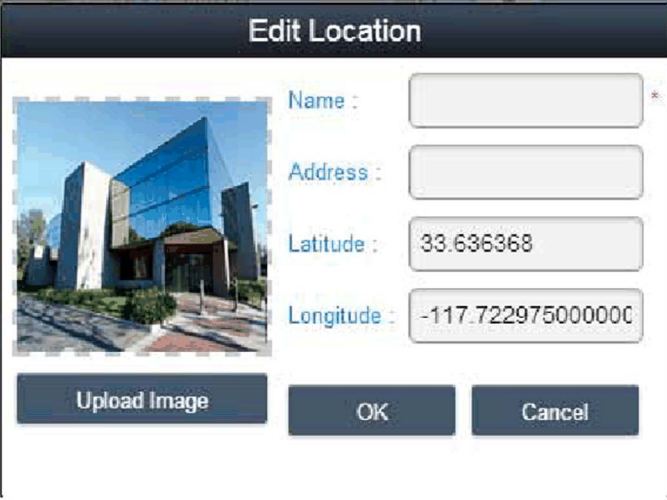
Step	Description
4	<p data-bbox="326 202 605 227">Add/Delete/Edit map location</p> <p data-bbox="326 229 1171 255">Add location: Select on one of account nodes and click Add button to add a new location:</p>  <p data-bbox="326 662 1232 714">Input location name, address, or coordination (latitude and longitude), upload image for location displaying and click OK to add the new location:</p>  <p data-bbox="326 1058 1236 1163">NOTE: Map view supports both Google and Baidu online map. These two maps adopt different coordination-system, you must input correct coordination according to online map selection (you can configure in the system settings). If you do not specify either address field or coordination, system will auto location this new added location at the center of current map view.</p>

Step	Description
5	<p>Delete location Click Edit button to switch to edit mode, click X icon ahead of selected location node to delete this location:</p>   <p>NOTE: If there are layouts or devices under selected location node, you must remove these nodes first before removing location node.</p>
6	<p>Edit location Click Edit button to switch to edit mode, click the location node/name to pop up the dialog of Edit Location to edit the content:</p>  <p>NOTE: Under this mode, drag the location icon on the right-side map view to relocate location.</p>

Step	Description
7	<p>Add layout Select on one of location nodes and click Add button to add a new layout. Input layout name and description, upload image for location displaying and click OK to add the new layout:</p>  <p>Delete layout: Click Edit button to switch to edit mode, click X icon ahead of selected layout node to delete this layout.</p> <p>NOTE: If there are devices under selected layout node, you must remove these nodes first before removing layout node.</p> <p>Edit layout: Click Edit button to switch to edit mode, click the location node/name to pop up the dialog of Edit Location to edit the content.</p>
8	<p>Add/Delete/Edit map device Add device: Select on one of accounts, location, or layout node and click Add button to add a new device. Newly added devices are by default located at the center of online or static image map:</p>  <p>Delete device: Click Edit to switch to edit mode and click X icon ahead of selected layout node to delete this device.</p> <p>Edit device: Click Edit button to switch to edit mode, drag the device icon on the right-side map view to relocate device. Under this mode, you can drag the device icon from the right-side map view to left-side account or location or layout node to change pop up its belonged level.</p>

Event Log

This procedure describes how to use the **Event Log** user interface:

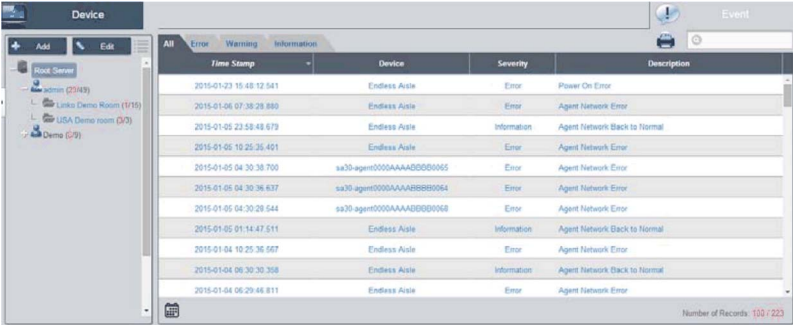
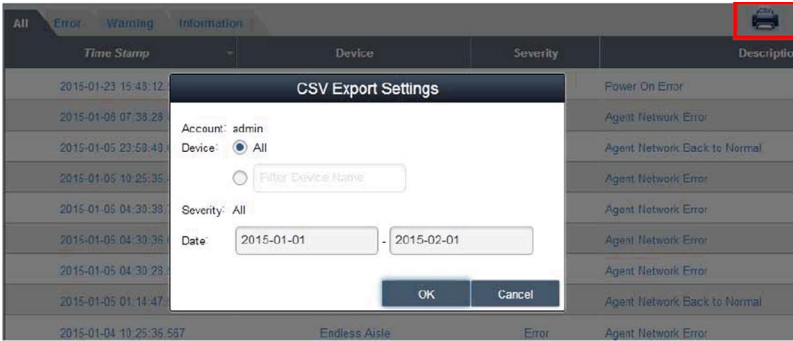
Step	Description
1	<p>Device event list Select user account or group to decide event range and select event log type (All/Error/Warning/Information) to browse related device events:</p> 
2	<p>Export CSV Select device and data/time range to export event log as CSV format to local side:</p> 

Account Setting - System Setting

Account Setting

This procedure describes how to use the **Account Setting** user interface:

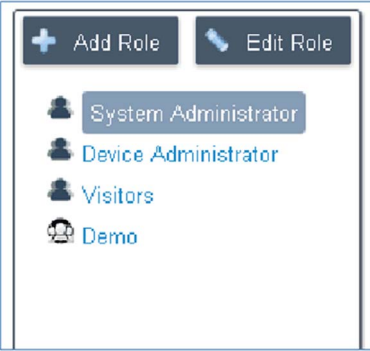
Step	Description										
1	<p>Click Account Setting from menu of up-right corner to pop up the dialog of account setting for configuring:</p>   <table border="1"> <thead> <tr> <th>Name</th> <th>Role</th> <th>Description</th> <th>Email</th> <th>Cell Phone</th> </tr> </thead> <tbody> <tr> <td>admin</td> <td>System Administrator</td> <td>System admin</td> <td></td> <td></td> </tr> </tbody> </table>	Name	Role	Description	Email	Cell Phone	admin	System Administrator	System admin		
Name	Role	Description	Email	Cell Phone							
admin	System Administrator	System admin									
2	<p>Default role System provides three default roles with pre-defined access rights: System Administrator, Device Administrator, and Visitors:</p>  <p>NOTE: The user rights of pre-defined role cannot be edited or deleted but only can be browsed.</p>										

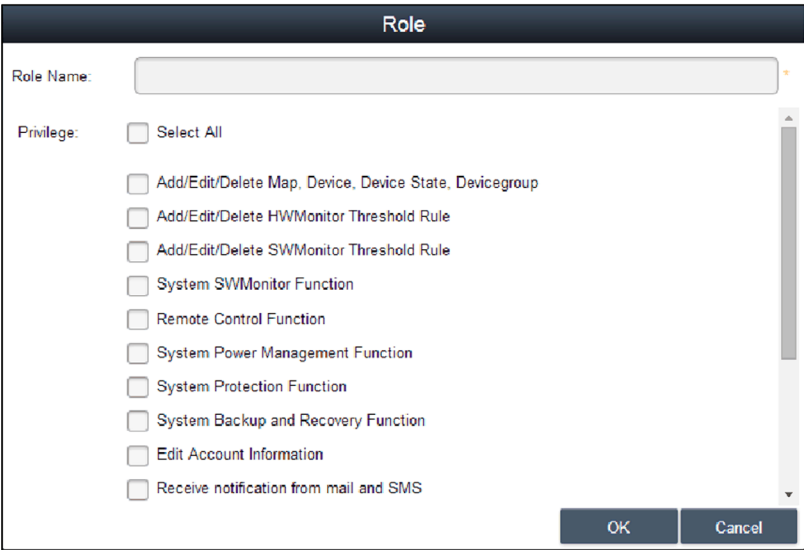
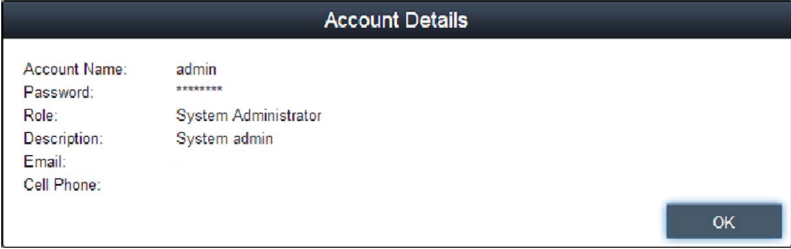
Step	Description
<p>3</p>	<p>View/Add/Delete/Edit custom role In addition to default role, you can add role with user-defined user rights. Add Role: Click Add Role to pop up the dialog of Role. Input role name and corresponding user rights to create a new role:</p>  <p>View/Edit custom role: Click Edit to switch to role edit mode. Click the icon to edit or view role user rights. Click the icon to delete custom role.</p>
<p>4</p>	<p>View/Add/Delete/Edit account View account: Select one of defaults or custom role and click arbitrary field in the account list to view the details of account:</p> 

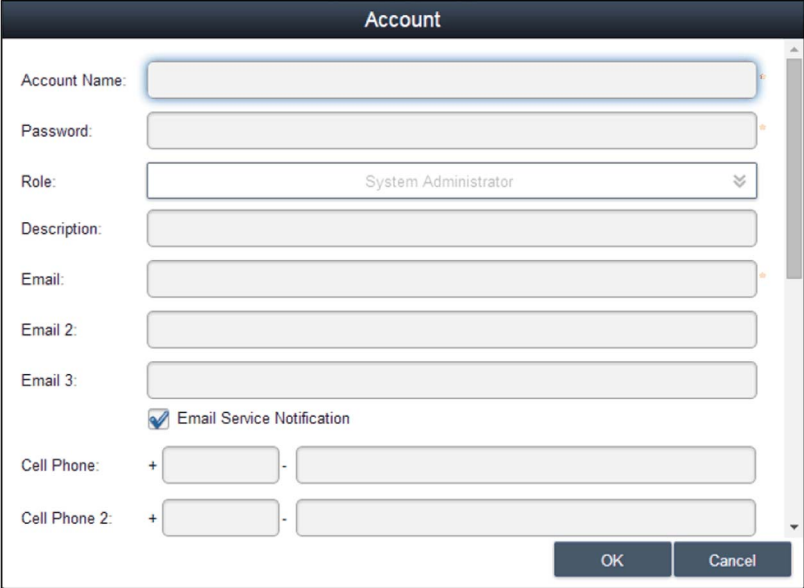

Step	Description
5	<p>Add account: Select one of defaults or custom role and click Add button to pop up the dialog for creating a new account:</p>  <p>Edit account: Click Edit button to switch to edit mode. Click arbitrary field in the account list to pop up the dialog for account editing.</p> <p>Delete account: Click Edit button to switch to edit mode. Click in the account list to delete account.</p> <p>NOTE: admin is a super system administrator that cannot be deleted.</p>

System Setting

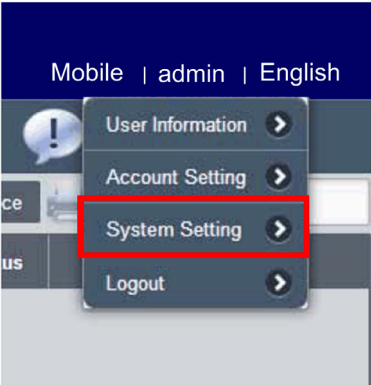
This procedure describes how to use the **System Setting** user interface:

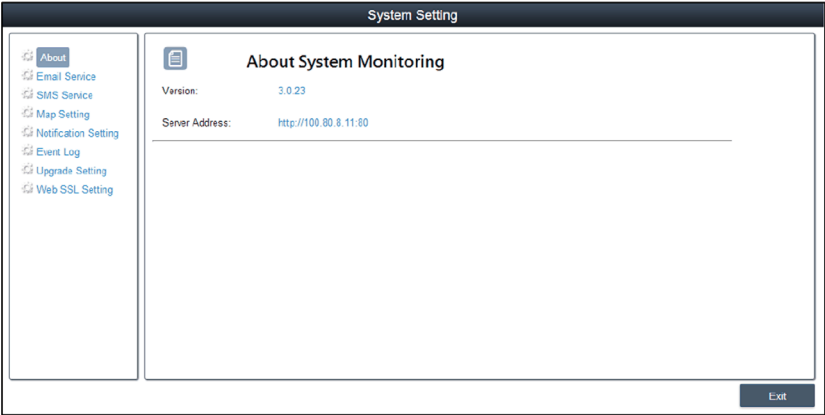
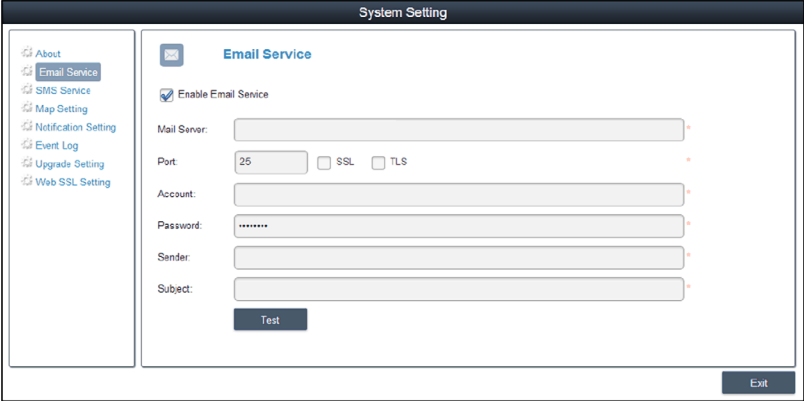
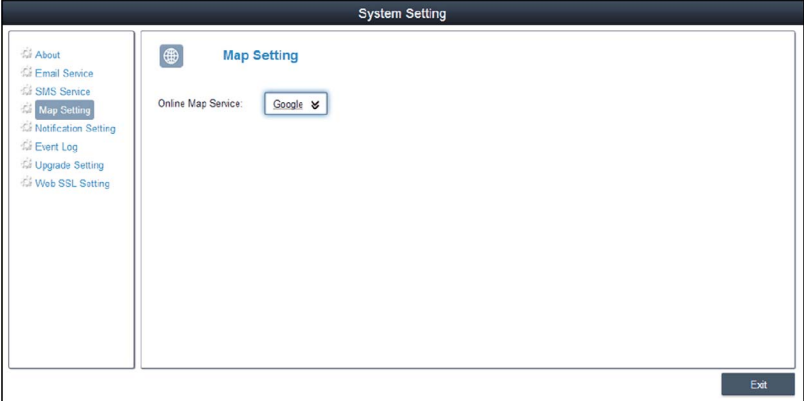
Step	Description
1	<p>Click System Setting from menu of up-right corner to pop up the dialog of system setting for configuring:</p> 

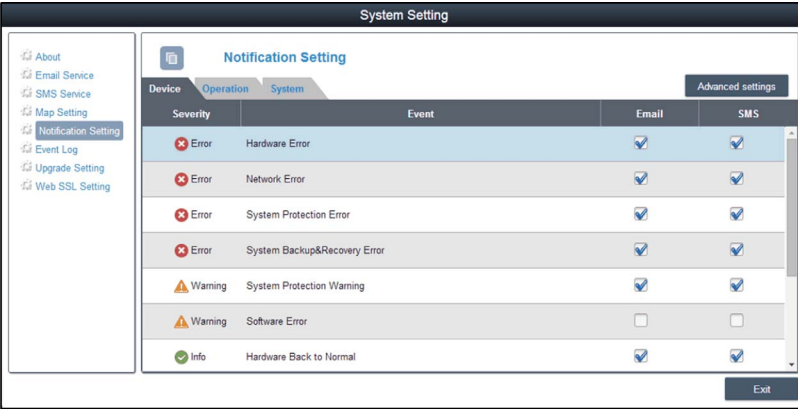
Step	Description
2	<p>About: Display server version and local address/port for Web portal:</p>  <p>The screenshot shows the 'System Setting' window with the 'About System Monitoring' tab selected. The left sidebar lists various settings: About, Email Service, SMS Service, Map Setting, Notification Setting, Event Log, Upgrade Setting, and Web SSL Setting. The main content area displays 'About System Monitoring' with the following information: Version: 3.0.23 and Server Address: http://100.80.8.11:80. An 'Exit' button is located at the bottom right of the window.</p>
3	<p>Email service: Use SMTP protocol to send notifications via Email Service. Before applying setting, click button to send a mail to check validity of settings:</p>  <p>The screenshot shows the 'System Setting' window with the 'Email Service' tab selected. The left sidebar is the same as in the previous step. The main content area displays 'Email Service' with the following settings: 'Enable Email Service' is checked. There are input fields for 'Mail Server', 'Port' (set to 25), 'Account', 'Password' (masked with dots), 'Sender', and 'Subject'. There are also checkboxes for 'SSL' and 'TLS'. A 'Test' button is located below the input fields. An 'Exit' button is at the bottom right.</p> <p>NOTE: You must enable this email service and check corresponding event notification setting and set up correct email address of device administrator to receive device email notifications while events occur.</p>
4	<p>Map setting On-line map supports Google, Baidu. Select map for client default map display:</p>  <p>The screenshot shows the 'System Setting' window with the 'Map Setting' tab selected. The left sidebar is the same as in the previous steps. The main content area displays 'Map Setting' with 'Online Map Service' set to 'Google' via a dropdown menu. An 'Exit' button is at the bottom right.</p>

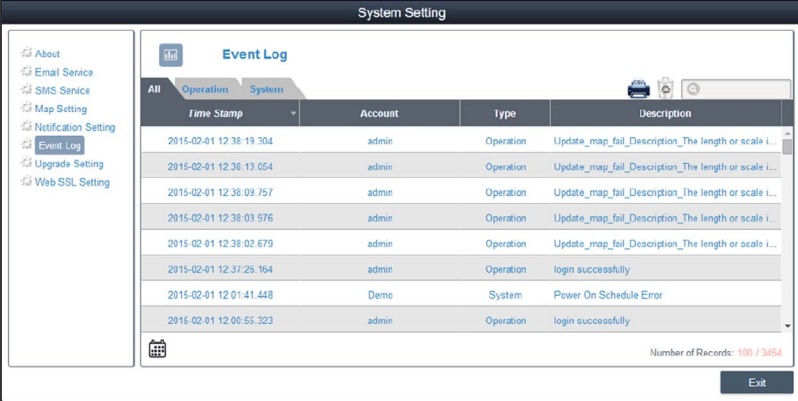
Step	Description																																				
<p>5</p>	<p>Notification setting Click tab Device/Operation/System to catalog related notification setting. Set event notify by Email on each item to enable receiving:</p>  <table border="1" data-bbox="473 388 1122 658"> <thead> <tr> <th>Severity</th> <th>Event</th> <th>Email</th> <th>SMS</th> </tr> </thead> <tbody> <tr> <td>Error</td> <td>Hardware Error</td> <td><input checked="" type="checkbox"/></td> <td><input checked="" type="checkbox"/></td> </tr> <tr> <td>Error</td> <td>Network Error</td> <td><input checked="" type="checkbox"/></td> <td><input checked="" type="checkbox"/></td> </tr> <tr> <td>Error</td> <td>System Protection Error</td> <td><input checked="" type="checkbox"/></td> <td><input checked="" type="checkbox"/></td> </tr> <tr> <td>Error</td> <td>System Backup&Recovery Error</td> <td><input checked="" type="checkbox"/></td> <td><input checked="" type="checkbox"/></td> </tr> <tr> <td>Warning</td> <td>System Protection Warning</td> <td><input checked="" type="checkbox"/></td> <td><input checked="" type="checkbox"/></td> </tr> <tr> <td>Warning</td> <td>Software Error</td> <td><input type="checkbox"/></td> <td><input type="checkbox"/></td> </tr> <tr> <td>Info</td> <td>Hardware Back to Normal</td> <td><input checked="" type="checkbox"/></td> <td><input checked="" type="checkbox"/></td> </tr> </tbody> </table>	Severity	Event	Email	SMS	Error	Hardware Error	<input checked="" type="checkbox"/>	<input checked="" type="checkbox"/>	Error	Network Error	<input checked="" type="checkbox"/>	<input checked="" type="checkbox"/>	Error	System Protection Error	<input checked="" type="checkbox"/>	<input checked="" type="checkbox"/>	Error	System Backup&Recovery Error	<input checked="" type="checkbox"/>	<input checked="" type="checkbox"/>	Warning	System Protection Warning	<input checked="" type="checkbox"/>	<input checked="" type="checkbox"/>	Warning	Software Error	<input type="checkbox"/>	<input type="checkbox"/>	Info	Hardware Back to Normal	<input checked="" type="checkbox"/>	<input checked="" type="checkbox"/>				
Severity	Event	Email	SMS																																		
Error	Hardware Error	<input checked="" type="checkbox"/>	<input checked="" type="checkbox"/>																																		
Error	Network Error	<input checked="" type="checkbox"/>	<input checked="" type="checkbox"/>																																		
Error	System Protection Error	<input checked="" type="checkbox"/>	<input checked="" type="checkbox"/>																																		
Error	System Backup&Recovery Error	<input checked="" type="checkbox"/>	<input checked="" type="checkbox"/>																																		
Warning	System Protection Warning	<input checked="" type="checkbox"/>	<input checked="" type="checkbox"/>																																		
Warning	Software Error	<input type="checkbox"/>	<input type="checkbox"/>																																		
Info	Hardware Back to Normal	<input checked="" type="checkbox"/>	<input checked="" type="checkbox"/>																																		
<p>6</p>	<p>Advanced settings Click Advanced Settings for message language of email and SMS, cycle days of system automatically sends inspection report, system warning of low hard disk space and external SYSLOG event server setting:</p> 																																				
<p>7</p>	<p>Event log Select event log type (all / operation / system) to browse related events:</p>  <table border="1" data-bbox="473 1315 1122 1547"> <thead> <tr> <th>Time Stamp</th> <th>Account</th> <th>Type</th> <th>Description</th> </tr> </thead> <tbody> <tr> <td>2015-02-01 12:38:19.304</td> <td>admin</td> <td>Operation</td> <td>Update_map_fail_Description_The length or scale l...</td> </tr> <tr> <td>2015-02-01 12:38:13.054</td> <td>admin</td> <td>Operation</td> <td>Update_map_fail_Description_The length or scale l...</td> </tr> <tr> <td>2015-02-01 12:38:09.757</td> <td>admin</td> <td>Operation</td> <td>Update_map_fail_Description_The length or scale l...</td> </tr> <tr> <td>2015-02-01 12:38:03.976</td> <td>admin</td> <td>Operation</td> <td>Update_map_fail_Description_The length or scale l...</td> </tr> <tr> <td>2015-02-01 12:38:02.679</td> <td>admin</td> <td>Operation</td> <td>Update_map_fail_Description_The length or scale l...</td> </tr> <tr> <td>2015-02-01 12:37:26.164</td> <td>admin</td> <td>Operation</td> <td>login successfully</td> </tr> <tr> <td>2015-02-01 12:01:41.448</td> <td>Demo</td> <td>System</td> <td>Power On Schedule Error</td> </tr> <tr> <td>2015-02-01 12:00:55.323</td> <td>admin</td> <td>Operation</td> <td>login successfully</td> </tr> </tbody> </table>	Time Stamp	Account	Type	Description	2015-02-01 12:38:19.304	admin	Operation	Update_map_fail_Description_The length or scale l...	2015-02-01 12:38:13.054	admin	Operation	Update_map_fail_Description_The length or scale l...	2015-02-01 12:38:09.757	admin	Operation	Update_map_fail_Description_The length or scale l...	2015-02-01 12:38:03.976	admin	Operation	Update_map_fail_Description_The length or scale l...	2015-02-01 12:38:02.679	admin	Operation	Update_map_fail_Description_The length or scale l...	2015-02-01 12:37:26.164	admin	Operation	login successfully	2015-02-01 12:01:41.448	Demo	System	Power On Schedule Error	2015-02-01 12:00:55.323	admin	Operation	login successfully
Time Stamp	Account	Type	Description																																		
2015-02-01 12:38:19.304	admin	Operation	Update_map_fail_Description_The length or scale l...																																		
2015-02-01 12:38:13.054	admin	Operation	Update_map_fail_Description_The length or scale l...																																		
2015-02-01 12:38:09.757	admin	Operation	Update_map_fail_Description_The length or scale l...																																		
2015-02-01 12:38:03.976	admin	Operation	Update_map_fail_Description_The length or scale l...																																		
2015-02-01 12:38:02.679	admin	Operation	Update_map_fail_Description_The length or scale l...																																		
2015-02-01 12:37:26.164	admin	Operation	login successfully																																		
2015-02-01 12:01:41.448	Demo	System	Power On Schedule Error																																		
2015-02-01 12:00:55.323	admin	Operation	login successfully																																		

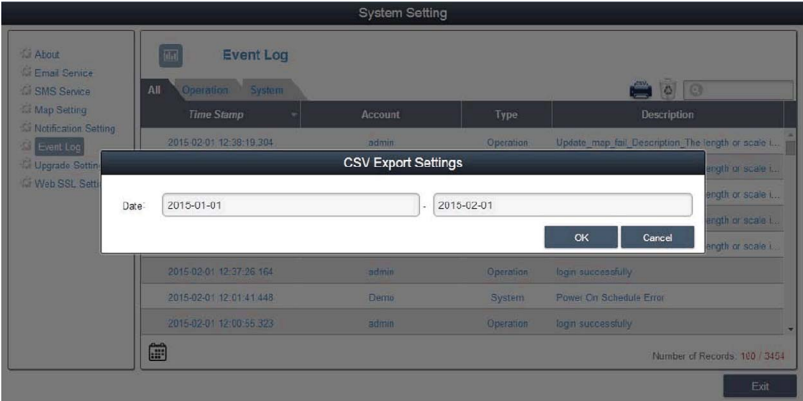
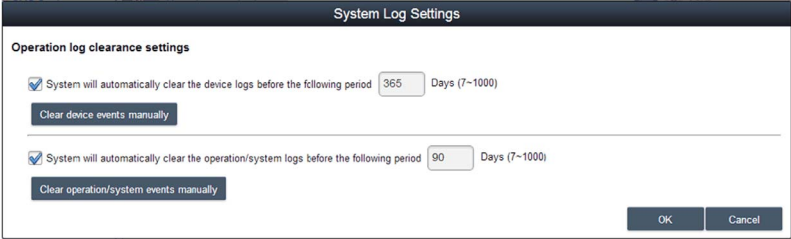
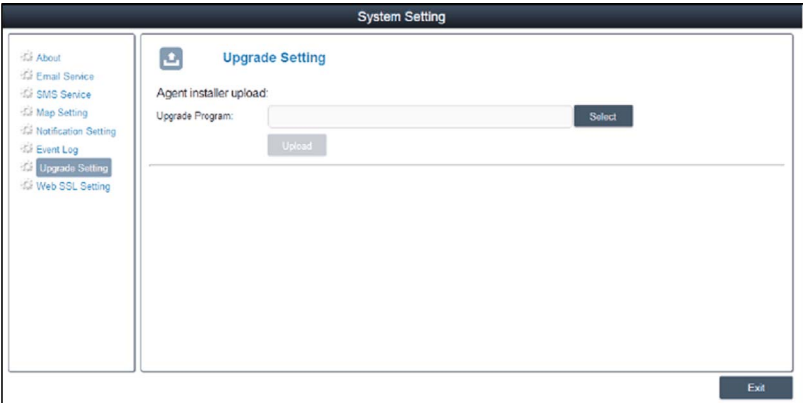
Step	Description
8	<p>Export CSV Select data/time range to export event log as CSV format to local side:</p>  <p>The screenshot shows the 'System Setting' window with the 'Event Log' tab selected. A 'CSV Export Settings' dialog box is open, allowing the user to specify a date range for exporting event logs. The 'Date' field is set to '2015-01-01' and the end date is '2015-02-01'. There are 'OK' and 'Cancel' buttons. In the background, an event log table is visible with columns for Time Stamp, Account, Type, and Description.</p>
9	<p>Clearance Manually or set up automatic period to clean event log:</p>  <p>The screenshot shows the 'System Log Settings' dialog box. Under 'Operation log clearance settings', there are two checked options: 'System will automatically clear the device logs before the following period' (set to 365 Days) and 'System will automatically clear the operation/system logs before the following period' (set to 90 Days). There are also buttons for 'Clear device events manually' and 'Clear operation/system events manually'. 'OK' and 'Cancel' buttons are at the bottom right.</p>
10	<p>Upgrade setting Use ValidationCode_Generator.exe tool to generate MD5 check code of uploading agent upgrade package. Input Check Code and select Upgrade Program to upload agent upgrade package to server. After uploading, system will auto check all connected agent devices and give hint tag of upgrading on corresponding device list when the user client logs in:</p>  <p>The screenshot shows the 'System Setting' window with the 'Upgrade Setting' tab selected. It features an 'Agent installer upload' section with a text input field and a 'Select' button. Below it is an 'Upgrade Program' section with a text input field and an 'Upload' button. An 'Exit' button is located at the bottom right.</p>

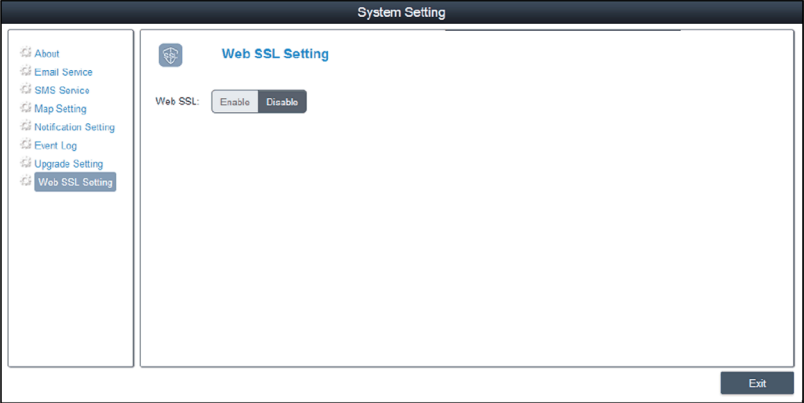
Step	Description
11	<p data-bbox="326 202 488 227">Web SSL setting</p> <p data-bbox="326 229 1218 255">User can switch SSL (Secure Sockets Layer) setting and select the port to open or close SSL:</p>  <p>The screenshot shows the 'System Setting' application window. On the left is a navigation menu with options: About, Email Service, SMS Service, Map Setting, Notification Setting, Event Log, Upgrade Setting, and Web SSL Setting (which is highlighted). The main content area is titled 'Web SSL Setting' and features a 'Web SSL:' label followed by two buttons: 'Enable' and 'Disable'. The 'Disable' button is currently selected. An 'Exit' button is located in the bottom right corner of the window.</p>

Chapter 11

Software API

Intelligent Management for Embedded Platform

Description

This **Software API** (Application Programming Interfaces) is a micro controller that provides embedded features for system integrators. Embedded features have been moved from the OS/BIOS level to the board level to increase reliability and to simplify integration. **Software API** runs whether the operating system is running or not; it can count the boot times and running hours of the device, monitor device health, and provide an advanced watchdog to handle errors found as they happen. **Software API** also comes with a secure and encrypted EEPROM for storing main security keys or other customer defined information. All the embedded functions are configured through an **API** (application programming interface) or by a **DEMO** tool. Pro-face provides this suite of **Software API** and the underlying drivers required. Also a set of user-friendly, intelligent, and integrated interfaces speed development, enhance security, and offer add-on value for Pro-face platforms.

NOTE: For details on Software API, refer to Pro-face website at <http://www.pro-face.com/trans/en/manual/1001.html>

Chapter 12

Maintenance

Subject of this Chapter

This chapter covers maintenance of the Box.

What Is in This Chapter?

This chapter contains the following topics:

Topic	Page
Reinstallation Procedure	200
Regular Cleaning and Maintenance	201

Reinstallation Procedure

Introduction

In certain cases, it may be necessary to reinstall the operating system.

Precautions to take:

- Keep static-producing materials (plastic, upholstery, carpeting) out of the immediate workspace.
- Do not remove ESD-sensitive components from their anti-static bags until you are ready to install them.
- When handling static-sensitive components, wear a properly grounded wrist strap (or equivalent).
- Avoid contact with exposed conductors and component leads.

Before Reinstallation

Hardware required:

- Recover media, refer to the leaflet of the recover media.

Setting up the hardware:

- Shut down Windows operating system in an orderly fashion and remove all power from the device.
- Disconnect all external peripherals.

NOTE: Save all main data onto a hard drive or a memory card. The reinstallation process returns the computer to its factory settings and erases all data.

Reinstallation

Refer to the procedure in the leaflet provided with the recovery media.

Regular Cleaning and Maintenance

Introduction

Inspect the Box periodically to determine its general condition. For example:

- Are all power cords and cables connected properly? Have any become loose?
- Are all installation fasteners holding the unit securely?
- Is the ambient temperature within the specified range?
- Are there any scratches or traces of dirt on the installation gasket?

NOTE: HDD health must be regularly checked with system monitor according to the usage. HDD is rotative media requiring to be changed regularly according to usage. Data on HDD must be saved regularly.

The following sections describe maintenance procedures for the Box, which can be carried out by a trained, qualified user.

DANGER

HAZARD OF ELECTRIC SHOCK, EXPLOSION OR ARC FLASH

- Remove all power from the device before removing any covers or elements of the system, and prior to installing or removing any accessories, hardware, or cables.
- Unplug the power cable from both the Box and the power supply.
- Always use a properly rated voltage sensing device to confirm power is off.
- Replace and secure all covers or elements of the system before applying power to the unit.
- Use only the specified voltage when operating the Box. The AC unit is designed to use 100...240 Vac input. The DC unit is designed to use 24 Vdc input. Always check whether your device is AC or DC powered before applying power.

Failure to follow these instructions will result in death or serious injury.

During operation, the surface temperature of the heat sink may exceed 70 °C (158 °F).

WARNING

RISK OF BURNS

Do not touch the surface of the heat sink during operation.

Failure to follow these instructions can result in death, serious injury, or equipment damage.

Cleaning Solutions

CAUTION

HARMFUL CLEANING SOLUTIONS

- Do not clean the unit or any component of the unit with paint thinner, organic solvents, or strong acids.
- Use only a mild soap or detergent that will not harm the poly carbonate material of the screen.

Failure to follow these instructions can result in injury or equipment damage.

Lithium Battery

The Box contains one battery, for backing up the real-time clock (RTC).

DANGER

EXPLOSION, FIRE, OR CHEMICAL HAZARD

- The battery must always be replaced with identical type.
- For battery replacement, contact the field services department.
- Do not recharge, disassemble, heat above 100 °C (212 °F), or incinerate.
- Recycle or properly dispose of used batteries.

Failure to follow these instructions will result in death or serious injury.

Appendices



Subject of this Part

This part provides the appendices for the Box products.

What Is in This Appendix?

The appendix contains the following chapters:

Chapter	Chapter Name	Page
A	Accessories	205
B	After-sales Service	207

Appendix A

Accessories

Accessories for the Box

Available Accessories

Accessories are available as options. The table shows the list of accessories available for the Box:

Reference	Description
Interfaces	
PFXZPBMPR42P2	Interface 2 x RS-422/485 isolated
PFXZPBMPR44P2	Interface 4 x RS-422/485
PFXZPBMPR24P2	Interface 4 x RS-232
PFXZPBMPR22P2	Interface 2 x RS-232 isolated
PFXZPBMPX16Y82	Interface 16 x DI / 8 x DO and 2 m cable and terminal
PFXZPBMPRE2	Interface 1 x Ethernet Gigabit IEEE 1588
PFXZPBMPPE2	Interface 2 x Ethernet Gigabit PoE
PFXZPBMPUS2P2	Interface 2 x USB 3.0
PFXZPBMPCANM2	Interface 2 x CANopen
PFXZPBMPBM2	Interface 1 x Profibus DP master with NVRAM
PFXZPBPHMC2	Cellular module: GPRS/GSM and antenna
PFXZPBPHAU2	Interface audio pin-header
PFXZPBMPX2	Interface - transmitter for PS5000
Drives	
PFXZPBHDD502	Hard disk drive 500 GB blank
PFXZPBHDD1002	Hard disk drive 1 TB blank
PFXZPESSD81	SSD 80 GB MLC
PFXZPESSD162	SSD 160 GB MLC
PFXZPBSSD242	SSD 240 GB MLC
PFXZPECFA162	CFast 16 GB MLC
PFXZPSCFA322	CFast 32 GB MLC
PFXZPBADHDD2	Adapter for HDD/SSD
Accessories	
PFXZPBPUAC2	AC power supply module 100 W
PFXZPSPUAC2	AC power supply module 60 W
PFXZPBEUUPB2	UPS module
PFXZPBCNDC2	DC power connectors (5 pieces)
PFXZPBCNAC2	AC power connectors (5 pieces)
PFXZPPAF12P2	Installation fastener (12 pieces)
PFXZPPDSP152	Protective sheet W15" (5 pieces)
CA3-DFS15-01	Protective sheet 15" (5 pieces)
PFXZPPDSP192	Protective sheet W19" (5 pieces)

Reference	Description
PFXZPPDSP222	Protective sheet W22" (5 pieces)
PFXZPPWG152	Gasket for W15" (1 piece)
PFXZPPWG153	Gasket for 15" (1 piece)
PFXZPPWG192	Gasket for W19" (1 piece)
PFXZPPWG222	Gasket for W22" (1 piece)
PFXZPBADCVDPDV2	DP-DVI converter
PFXZPBADVS02	VESA mounting kit for 0 slot
PFXZPBADVS22	VESA mounting kit for 2 slot
PFXZPBIUFAN2	FAN kit
PFXZPBFTFAN2	FAN filter (5 pieces)
PFXZPPDADDP2	Display Adapter (DP)
PFXZPPDMPRX2	Interface - receiver for display module
PFXZPPDMPTX2	Interface - transmitter for display module
Cables	
PFXZPBCBUP32	UPS 3 m cable (power and communication)
PFXZPBCBDPDV32	DP-DVI cable 3 m
PFXZPBCBDP52	DP-DP cable 5 m
FP-US00	USB cable 5 m

Appendix B

After-sales Service

After-sales Service

Information

For details on after-sales service, refer to Pro-face website at

<http://www.pro-face.com/trans/en/manual/1001.html>

