

Pro-face

by **Schneider** Electric

LT-4201TM/4301TM Installation Guide

The information provided in this documentation contains general descriptions and/or technical characteristics of the performance of the products contained herein. This documentation is not intended as a substitute for and is not to be used for determining suitability or reliability of these products for specific user applications. It is the duty of any such user or integrator to perform the appropriate and complete risk analysis, evaluation and testing of the products with respect to the relevant specific application or use thereof. Neither Schneider Electric nor any of its affiliates or subsidiaries (hereinafter, referred to as Schneider Electric) shall be responsible or liable for misuse of the information that is contained herein. If you have any suggestions for improvements or amendments or have found errors in this publication, please notify us.

You agree not to reproduce, other than for your own personal, noncommercial use, all or part of this document on any medium whatsoever without permission of Schneider Electric, given in writing. You also agree not to establish any hypertext links to this document or its content. Schneider Electric does not grant any right or license for the personal and noncommercial use of the document or its content, except for a non-exclusive license to consult it on an "as is" basis, at your own risk. All other rights are reserved.

All pertinent state, regional, and local safety regulations must be observed when installing and using this product. For reasons of safety and to help ensure compliance with documented system data, only the manufacturer should perform repairs to components.

When devices are used for applications with technical safety requirements, the relevant instructions must be followed.

Failure to use Schneider Electric software or approved software with our hardware products may result in injury, harm, or improper operating results.

Failure to observe this information can result in injury or equipment damage.

Copyright © 2018.03 Schneider Electric Japan Holdings Ltd. All Rights Reserved.

Safety Information



Important Information

NOTICE

Read these instructions carefully, and look at the equipment to become familiar with the device before trying to install, operate, service, or maintain it. The following special messages may appear throughout this documentation or on the equipment to warn of potential hazards or to call attention to information that clarifies or simplifies a procedure.



The addition of this symbol to a “Danger” or “Warning” safety label indicates that an electrical hazard exists which will result in personal injury if the instructions are not followed.



This is the safety alert symbol. It is used to alert you to potential personal injury hazards. Obey all safety messages that follow this symbol to avoid possible injury or death.

DANGER

DANGER indicates a hazardous situation which, if not avoided, **will result in** death or serious injury.

WARNING

WARNING indicates a hazardous situation which, if not avoided, **could result in** death or serious injury.

CAUTION

CAUTION indicates a hazardous situation which, if not avoided, **could result in** minor or moderate injury.

NOTICE

NOTICE is used to address practices not related to physical injury.

PLEASE NOTE

Electrical equipment should be installed, operated, serviced, and maintained only by qualified personnel. No responsibility is assumed by Schneider Electric for any consequences arising out of the use of this material.

A qualified person is one who has skills and knowledge related to the construction and operation of electrical equipment and its installation, and has received safety training to recognize and avoid the hazards involved.

About the Book



At a Glance

Document Scope

This guide describes how to install the LT-4201TM/4301TM. For more detailed information, refer to the manuals indicated below.

Global Code

A global code is assigned to every Pro-face product as a universal model number.

For more information on product models and their matching global codes, please refer to the following URL:

<http://www.pro-face.com/trans/en/manual/1003.html>

Validity Note

This documentation is valid for GP-Pro EX V4.0 or later.

The characteristics presented in the present manual should be the same as those that appear online. In line with our policy of constant improvement we may revise content over time to improve clarity and accuracy. In the event that you see a difference between the manual and online information, use the online information as your reference.

Related Documents

Title of Documentation	Reference Number
GP-Pro EX Reference Manual Maintenance/Troubleshooting Guide	<ul style="list-style-type: none"> • Troubleshooting Help for solving problems. • Maintenance Details on the LT unit's Offline Mode
GP-Pro EX Device/PLC Connection Manual	System configuration of connected devices (PLCs and other devices), communication settings examples, connection wiring diagram, and other details.
LT-4201TM/4301TM Hardware Manual	Specifications, dimensions, accessories, system design, standards, and other details.

You can download these technical publications and other technical information from our website at <http://www.pro-face.com/trans/en/manual/1001.html>.

Product Related Information

 **DANGER****HAZARD OF ELECTRIC SHOCK, EXPLOSION OR ARC FLASH**

- Disconnect all power from all equipment including connected devices prior to removing any covers or doors, or installing or removing any accessories, hardware, cables, or wires except under the specific conditions specified in the appropriate hardware guide for this equipment.
- Always use a properly rated voltage sensing device to confirm the power is off where and when indicated.
- Replace and secure all covers, accessories, hardware, cables, and wires and confirm that a proper ground connection exists before applying power to the unit.
- Use only the specified voltage when operating this equipment and any associated products.

Failure to follow these instructions will result in death or serious injury.

This equipment has been designed to operate outside of any hazardous location. Only install this equipment in zones known to be free of a hazardous atmosphere.

 **DANGER****POTENTIAL FOR EXPLOSION**

Install and use this equipment in non-hazardous locations only.

Failure to follow these instructions will result in death or serious injury.

WARNING

LOSS OF CONTROL

- Consider the potential failure modes of control paths in the machine control system design, such as:
 - The possibility of backlight failure,
 - Unanticipated link transmission delays or failures,
 - The operator being unable to control the machine,
 - The operator making errors in the control of the machine.
- Design outside the LT operations such as emergency stop, safety circuits, interlocks that operate with opposing actions such as clockwise/counterclockwise rotation, and circuits that prevent machine damage with positioning limits on top, bottom, and movement.
- For important operations handled by switches, design your system to use a separate hardware device. This is to reduce the occurrence of incorrect outputs or malfunctions.
- Observe all accident prevention regulations and local safety guidelines.¹
- Test individually and thoroughly each implementation of the equipment for correct operation before service.

Failure to follow these instructions can result in death, serious injury, or equipment damage.

¹ For additional information, refer to NEMA ICS 1.1 (latest edition), "Safety Guidelines for the Application, Installation, and Maintenance of Solid State Control" and to NEMA ICS 7.1 (latest edition), "Safety Standards for Construction and Guide for Selection, Installation and Operation of Adjustable-Speed Drive Systems" or their equivalent governing your particular location.

 部件名称 Part Name	有害物质 – Hazardous Substances					
	铅 (Pb)	汞 (Hg)	镉 (Cd)	六价铬 (Cr (VI))	多溴联苯 (PBB)	多溴二苯醚 (PBDE)
金属部件 Metal parts	X	O	O	O	O	O
塑料部件 Plastic parts	O	O	O	O	O	O
电子件 Electronic	X	O	O	O	O	O
触点 Contacts	O	O	O	O	O	O
线缆和线缆附件 Cables & cabling accessories	O	O	O	O	O	O
本表格依据 SJ/T11364 的规定编制。 O: 表示该有害物质在该部件所有均质材料中的含量均在 GB/T 26572 规定的限量要求以下。 X: 表示该有害物质至少在该部件的某一均质材料中的含量超出 GB/T 26572 规定的限量要求。 This table is made according to SJ/T 11364. O: indicates that the concentration of hazardous substance in all of the homogeneous materials for this part is below the limit as stipulated in GB/T 26572. X: indicates that concentration of hazardous substance in at least one of the homogeneous materials used for this part is above the limit as stipulated in GB/T 26572.						

LT-4201TM/4301TM of Panels

LT Range

Thank you for purchasing the LT4000 Series unit (hereafter referred to as the “LT”):

Series	Model Names	Models	Digital Input	Digital Output	Analog Input	Analog Output	Screen Size
LT4000 Series	LT-4201TM (Modular Type DIO)	PFXLM4201TADDC PFXLM4201TADDK	20 Points Standard Input (2 Points for Fast Input)	10 Points Standard Output and 2 Points Fast Output	None	None	3.5 in.
	LT-4301TM (Modular Type DIO)	PFXLM4301TADDC PFXLM4301TADDK					5.7 in.
	LT-4000M (Modular Type DIO)	PFXLM4B01DDC PFXLM4B01DDK					None
	LT-4201TM (Modular Type Analog)	PFXLM4201TADAC PFXLM4201TADAK	12 Points Standard Input (2 Points for Fast Input)	6 Points Standard Output and 2 Points Fast Output	2 ch analog inputs (13-bit) and 2 ch analog inputs (16-bit) for Thermocouple	2 ch analog outputs (12-bit)	3.5 in.
	LT-4301TM (Modular Type Analog)	PFXLM4301TADAC PFXLM4301TADAK					5.7 in.
	LT-4000M (Modular Type Analog)	PFXLM4B01DAC PFXLM4B01DAK					None
	3.5 inch display module	PFXXM4200TP	None				3.5 in.
	5.7 inch display module	PFXXM4300TP	None				5.7 in.

NOTE: Fast Input and Fast Output are generic terms for the following functions:
 Fast Input: High-speed Counter Input and Pulse Catch Input.
 Fast Output: Pulse Output, PWM Output and High-speed Counter Synchronize Output.

Display Module/Rear Module Separation Cable Range

Reference	Cable Length
PFXZXMADSM31	3 m (9.84 ft.)
PFXZXMADSM51	5 m (14.40 ft.)

NOTE: The outer diameter of the cable is 8 mm (0.13 in.). To assemble this product, you need 20 mm (0.78 in.) more space to bend the cable in the end of the rubber.

Agency Certifications for LT Unit

For information on Standards and Regulations, such as certified models and certificates, see the marking on the product or the following link:

<http://www.pro-face.com/trans/en/manual/1002.html>

LT unit is manufactured in accordance with UL 508 and CSA C22.2 n°142 for industrial control equipment.

For use on a flat surface of a Type 1, Type 4X (indoor use only) enclosure.

Hazardous Substances

This product is a device for use in factory systems. When using this product in a system, the system should comply with the following standards in regards to the installation environment and handling:

- WEEE, Directive 2012/19/EU
- RoHS, Directives 2011/65/EU
- RoHS China, Standard (GB/T 26572)
- REACH regulation EC 1907/2006

CE Markings

This product conforms to the necessary requirements of the following Directives for applying the CE label:

- 2006/95/EC Low Voltage Directive
- 2004/108/EC EMC Directive

This conformity is based on compliance with IEC61131-2.

CAUTION

ENVIRONMENTAL HAZARDS TO THE EQUIPMENT

- Allow the device to reach the surrounding air temperature, not exceeding 50 °C (122 °F), before turning the device on.
- Do not turn on the device if condensation has occurred inside the device. After it is completely dry again, the device may be turned on.
- Do not expose the device to direct sunlight.
- Do not obstruct the vents in the device casing.
- Remove any dust from the device before turning it on.
- Ensure that the cable installation fasteners are not damaged. Replace them, if necessary.
- Mount the device into an enclosure that meets the IP65 level of protection.

Failure to follow these instructions can result in injury or equipment damage.

WARNING

RISK OF EXPLOSION IN HAZARDOUS LOCATIONS

- Verify that the power, input, and output (I/O) wiring are in accordance with Class I, Division 2 wiring methods.
- Do not substitute components that may impair compliance to Class I, Division 2.
- Do not connect or disconnect equipment unless power has been switched off or the area is known to be non-hazardous.
- Securely lock externally connected units and each interface before turning on the power supply.
- Do not, connect, or disconnect USB cable unless area is known to be non-hazardous.
- Potential electrostatic charging hazard: wipe the front panel of the terminal with a damp cloth before turning ON.

Failure to follow these instructions can result in death, serious injury, or equipment damage.

Interfaces are: COM1, Ethernet, USB1 and USB2.

WARNING

RISK OF EXPLOSION IN HAZARDOUS LOCATIONS

- Do not disconnect while circuit is live.
- Potential electrostatic charging hazard: wipe the front panel of the terminal with a damp cloth before turning ON.

Failure to follow these instructions can result in death, serious injury, or equipment damage.

Package Contents

Verify that all items shown in the figure are present in your package:

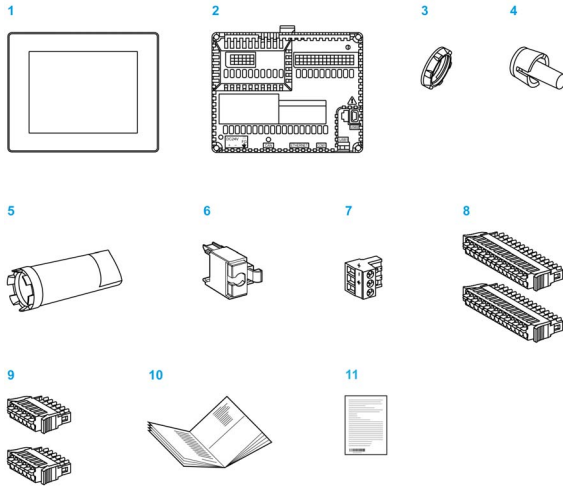

Legend	Description	Package Type		
		LT Unit	Display Module	Rear Module
1	Display module	Yes	Yes	No
2	Rear module	Yes	No	Yes
3	Display installation nut (attached to the display module)	Yes	Yes	No
4	Anti-rotation tee	Yes	Yes	No
5	Socket wrench	Yes	No	No
6	USB clamp type A	Yes	No	Yes
7	DC power supply connector	Yes	No	Yes
8	I/O connector 15-pin	2	No	2
9	I/O connector 6-pin	2	No	2
10	LT-4201TM/4301TM Installation Guide	Yes	No	Yes
11	Warning / Caution information	Yes		

Handling the LCD

⚠ CAUTION

SERIOUS EYE AND SKIN INJURY

The liquid present in the LCD contains an irritant:

- Avoid direct skin contact with the liquid.
- Wear gloves when you handle a broken or leaking unit.
- Do not use sharp objects or tools in the vicinity of the LCD touch panel.
- Handle the Panel carefully to prevent puncture, bursting, or cracking of the Panel material.

Failure to follow these instructions can result in injury or equipment damage.

If the Panel is damaged and any liquid comes in contact with your skin, immediately rinse the area with running water for at least 15 min.

If the liquid gets in your eyes, immediately rinse your eyes with running water for at least 15 minutes and consult a doctor.

Product Label Sticker

You can identify the product version (PV) and the revision level (RL) from the product label on the panel.

The following diagram is a representation of a typical label:

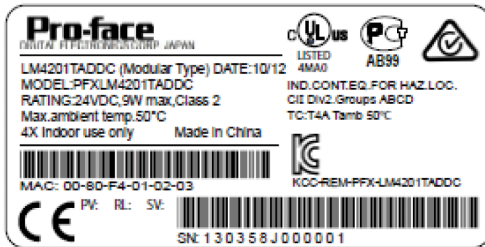

LT4200/4300 Series model which unit's version number (PV) is 02 or later can also be used as Rear Module.

LT-4201TM/4301TM and Rear Module Parts Identification:

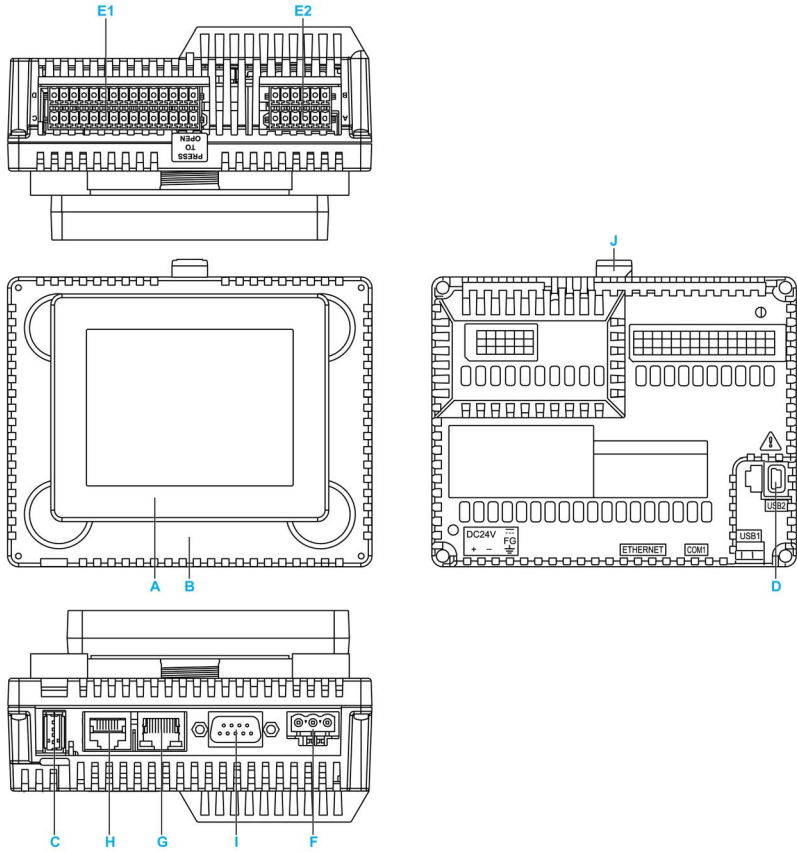

Part	Description
A	Display module
B	Rear module
C	USB (type A) interface connector (USB1)
D	USB (mini B) interface connector (USB2)
E1	I/O terminal block 1
E2	I/O terminal block 2
F	DC power supply connector
G	Ethernet interface
H	Serial link (RS-232C/485)
I	CANopen interface
J	Yellow button lock

Installation

Inserting the Display Module with an Anti-Rotation Tee

Create a panel cut-out and insert the display module into the panel from the front. The figure shows the panel cut-out:

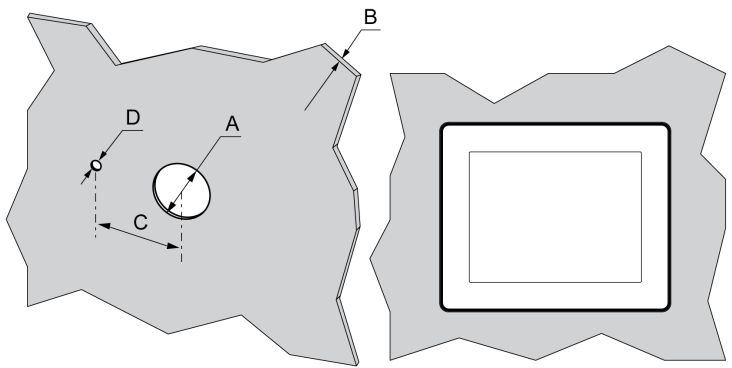

Dimensions

A	B (1)	B (2)	C	D
22.50 ^{0/-0.30} mm (0.88 ^{0/-0.01} in.)	1.5...6 mm (0.06...0.23 in.)	3...6 mm (0.11...0.23 in.)	30 ^{0/-0.20} mm (1.18 ^{0/-0.0007} in.)	4 ^{0/-0.20} mm (0.15 ^{0/-0.007} in.)
(1) Steel sheet				
(2) Glass fiber reinforced plastics (minimum GF30)				

NOTE: The display module supports a rotating torque of 6 N•m (53.10 lb-in). Without the tee option, the display module supports a rotating torque of 2.5 N•m (22.12 lb-in).

Installing the LT Display

The figure shows the assembly:

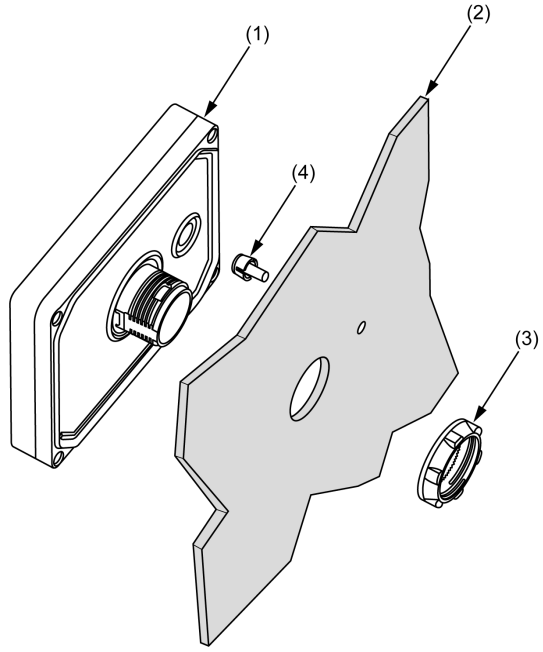

- (1) Display module
- (2) Panel
- (3) Display installation nut
- (4) Anti-rotation tee

Installing the LT Display Module with Spacer

The spacer supplied in the accessory kit PFXZGMAK1 (sold separately), allows mounting the product on a:

- steel sheet support with a thickness between 1 and 1.5 mm (0.039 in. and 0.059 in.)
- plastic support with a thickness between 1 and 3 mm (0.039 in. and 0.118 in.)
- glass fiber reinforced plastic with a thickness between 2 and 3 mm (0.078 in. and 0.118 in.)

The figure shows the assembly with the Panel spacer:

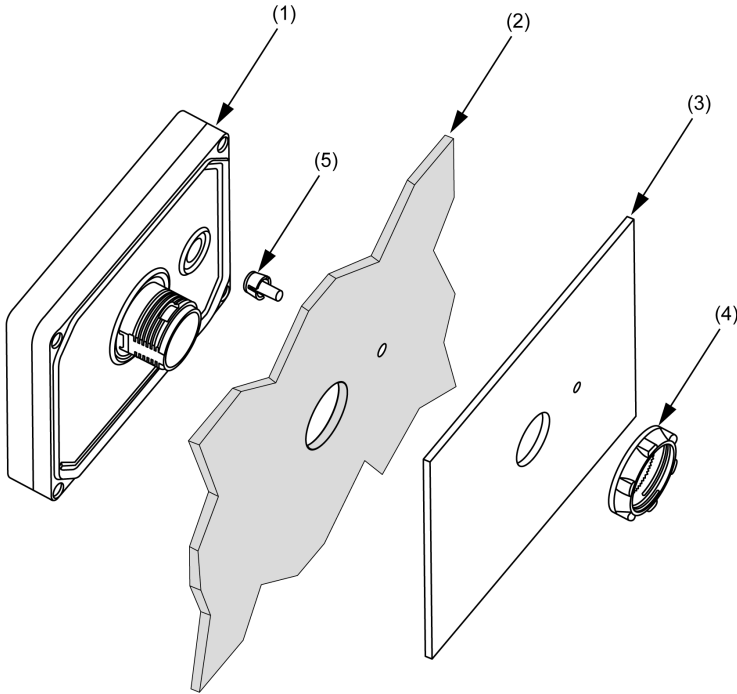

- (1) Display module
- (2) Panel
- (3) Spacer
- (4) Display installation nut
- (5) Anti-rotation tee

Installation of the LT Unit

In order to correctly run an application on the LT, both the display module and the rear module must be connected.

WARNING

EXPLOSION HAZARD

- Do not connect or disconnect while circuit is live.
- Potential electrostatic charging hazard: wipe the front panel of the terminal with a damp cloth before turning ON.
- Refer to Hardware Manual for instructions

Failure to follow these instructions can result in death, serious injury, or equipment damage.

If you power up the rear module without connecting the display module, the logic controller does not start and all outputs remain in the initial state. The power must be off when you connect the 2 modules.

There are 2 ways to install the LT.

Installing the LT on the panel:

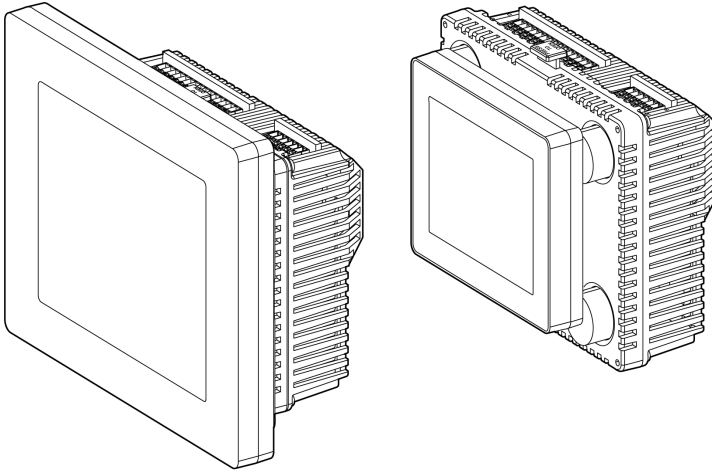

Installing the rear module on a DIN rail with a display module/rear module separation cable:

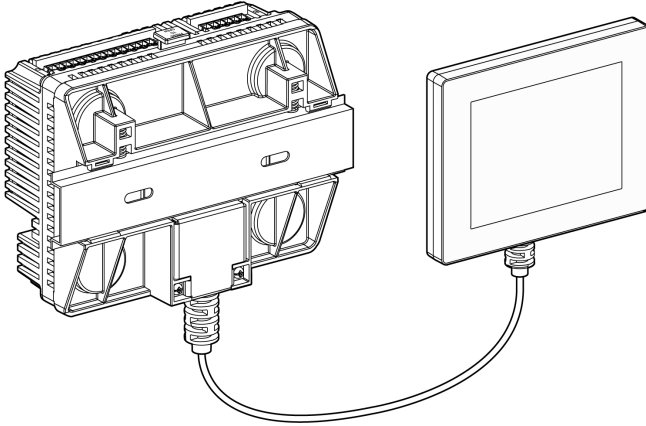

Setup Procedure

Mount the unit in an enclosure that provides a clean, dry, robust, and controlled environment (IP65 enclosure or UL508 4x if indoors).

Before installing the LT Unit verify that:

- The installation panel or cabinet surface is flat (planarity tolerance: 0.5 mm (0.019 in.)), in good condition and has no jagged edges. Metal reinforcing strips may be attached to the inside of the panel, near the panel cut-out, to increase the rigidity.
- The panel should be designed to avoid any induced vibration resonance on the rear module exceeding a punctual factor of 10 and to avoid any induced permanent vibration resonance.

To reduce the resonance use the panel adaptor accessory.

- The ambient operating temperature and the ambient humidity are within their specified ranges:

Horizontal installation: 0...50 °C (32...122 °F)

Vertical installation: 0...40 °C (32...104 °F)

Relative humidity: 5...85% w/o condensation (non-condensing, wet bulb Temperature 39 °C (102.2 °F) or less)

- The heat from surrounding equipment does not cause the unit to exceed its specified operating temperature.

- When installing the display in a vertical position (portrait view), the logo on the display face must be on the right side to keep the power connector at the top:

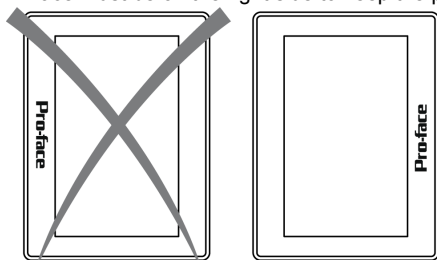

NOTE: For use in Pollution Degree 2 environments.

- The panel face is not inclined more than 30° when installing the unit in a slanted panel:

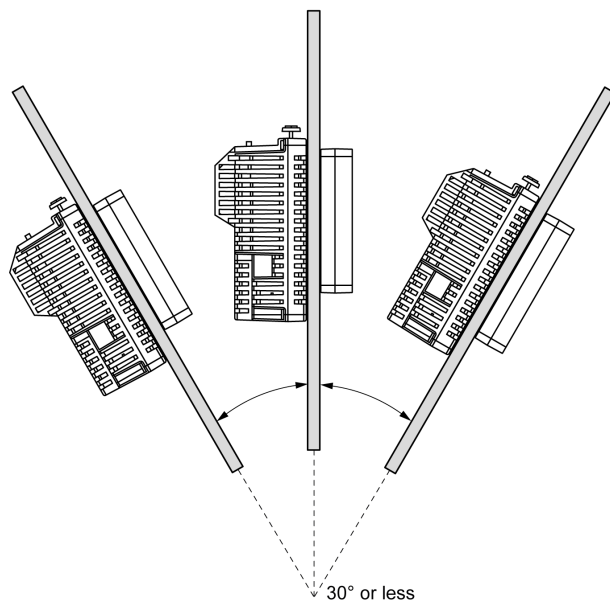

- The power plug is positioned vertically when the unit is vertically installed.

- The unit is at least 100 mm (3.94 in.) away from adjacent structures and other equipment for easier maintenance, operation, and improved ventilation:

mm
in.

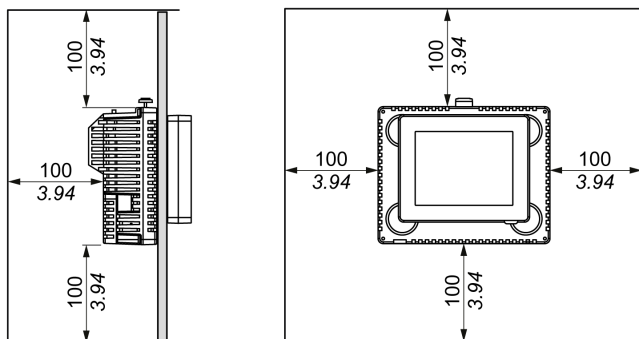

The figure shows how to install the panel with the rear module:

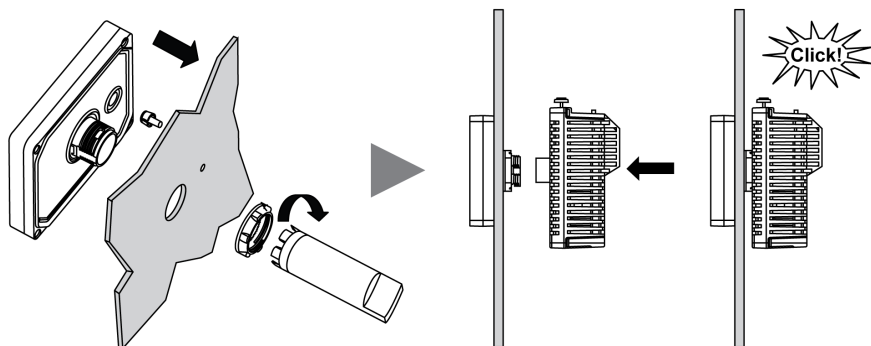

- 1 Create the correct sized holes required to install the unit, using the panel cut-out dimension.
- 2 Insert the display module (with the tee, if required) into the panel hole (use a torque between 1.2 and 2 N•m (10.62 lb-in and 17.70 lb-in) to screw the nut with the tightening wrench).
- 3 Insert and push the rear module until it locks into place.

To remove the rear module, push the yellow button to unlock it, and then pull out the rear module:

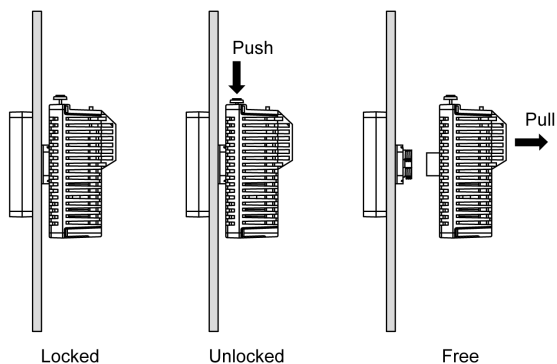

NOTICE

EQUIPMENT DAMAGE

Be sure to remove the rear module from the display module without twisting.

Failure to follow these instructions can result in equipment damage.

Correct Mounting Position

The rear module must be mounted with steel sheet horizontally or vertically plane as shown in the figure:

Horizontal Mounting

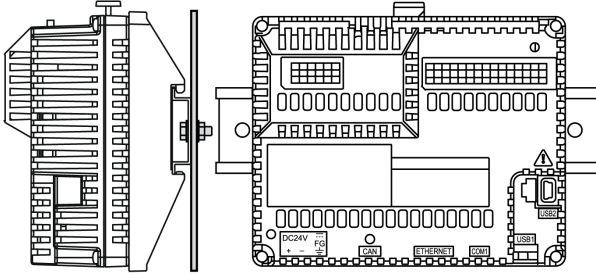

Vertical Mounting

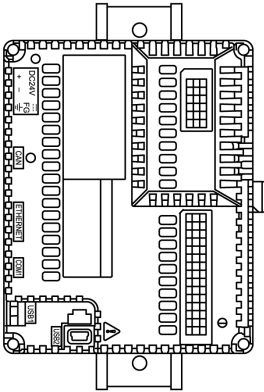

NOTE: Keep adequate spacing for proper ventilation to maintain an ambient temperature between 0...50 °C (32...122 °F) for horizontal installation and 0...40 °C (32...104 °F) for vertical installation.

Incorrect Mounting Position

The rear module should only be positioned in correct mounting position to help ensure an adequate air flow through the product.

The figures show the incorrect mounting positions:

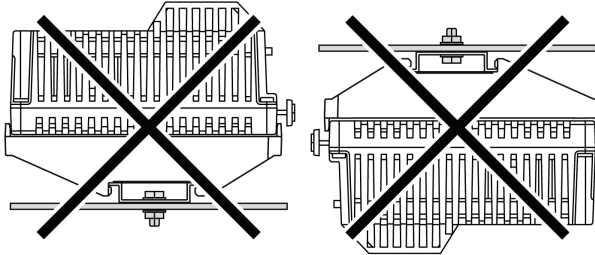

Minimum Clearance When Installing the Rear Module on a DIN Rail

⚠ WARNING

UNINTENDED EQUIPMENT OPERATION

- Place devices dissipating the most heat at the top of the cabinet and ensure adequate ventilation.
- Avoid placing this equipment next to or above devices that might cause overheating.
- Install the equipment in a location providing the minimum clearances from all adjacent structures and equipment as directed in this document.
- Install all equipment in accordance with the specifications in the related documentation.

Failure to follow these instructions can result in death, serious injury, or equipment damage.

The rear module has been designed as an IP20 product and must be installed in an enclosure. The clearances must be respected when installing the product:

- Distance and separation between the rear module and the front installation panel.
- Distance and separation between the rear module and wiring ducts.
- Distance and separation between the rear module and peripherals.

The figure shows the minimum clearance for the rear module:

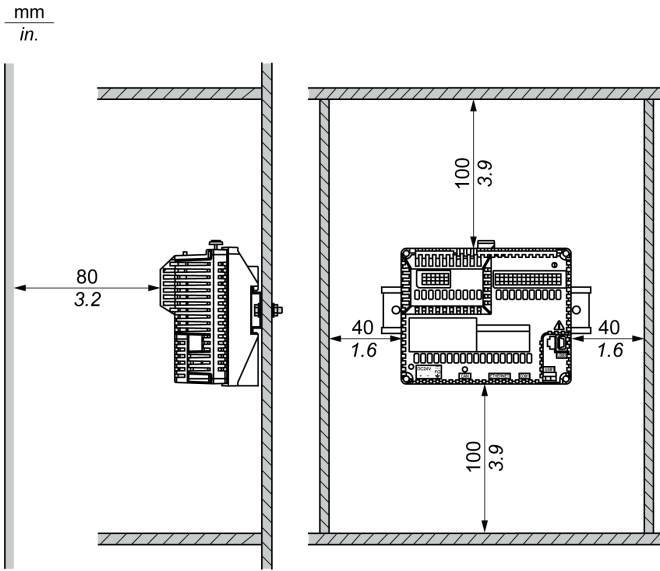

Installing the Rear Module on a DIN Rail

The following procedure describes how to install the rear module on a DIN rail:

- Fasten the DIN rail to a panel surface using screws.
- Affix the display module/rear module separation cable to the rear module.
- Position the top groove of the rear module on the top edge of the DIN rail and press the assembly against the DIN rail until you hear the DIN rail clip click into place.
- Install the display module onto the cabinet.
- Affix the display module/rear module separation cable to the display.

The figure shows how to install the rear module on a DIN rail:

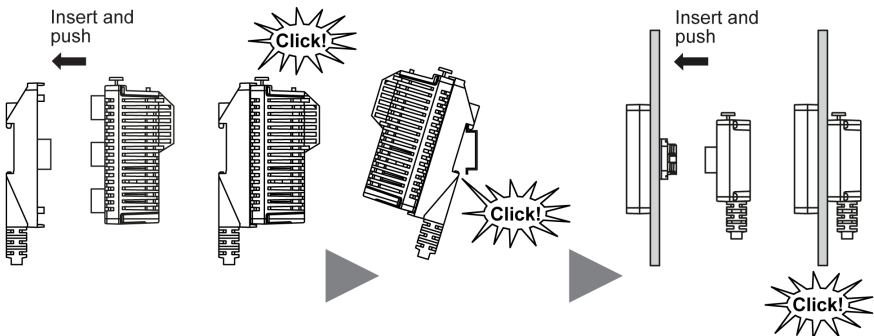

Removing the Rear Module from a DIN Rail

The following procedure describes how to remove the rear module from a DIN rail:

- Push down the yellow lock button of the rear module and remove it from the display module/rear module separation cable.
- Push down the display module/rear module separation cable from the DIN rail.

The figure shows how to remove the rear module from a DIN rail:

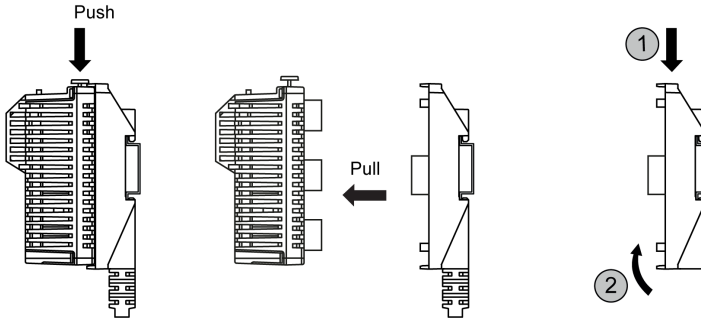

Wiring Principles

Wiring Rules and Recommendations

There are several rules that must be followed when wiring the LT system.

Wiring Guidelines

DANGER

HAZARD OF ELECTRIC SHOCK, EXPLOSION OR ARC FLASH

- Disconnect all power from all equipment including connected devices prior to removing any covers or doors, or installing or removing any accessories, hardware, cables, or wires except under the specific conditions specified in the appropriate hardware guide for this equipment.
- Always use a properly rated voltage sensing device to confirm the power is off where and when indicated.
- Replace and secure all covers, accessories, hardware, cables, and wires and confirm that a proper ground connection exists before applying power to the unit.
- Use only the specified voltage when operating this equipment and any associated products.

Failure to follow these instructions will result in death or serious injury.

The following rules must be applied when wiring a LT system:

- I/O and communication wiring must be kept separate from the power wiring. Route these 2 types of wiring in separate cable ducting.
- Verify that the operating conditions and environment are within specification.
- Use proper wire sizes to meet voltage and current requirements.
- Use copper conductors.
- Use twisted-pair, shielded cables for analog, and/or fast I/O.
- Use twisted-pair, shielded cables for networks, and fieldbus.
- For the power connector, refer to DC power supply wiring diagram.
- When terminals A2 and B2 (signal name: Q1, Q0) are wired to external I/O, use the same power source for external I/O and the LT. Refer to Power Supply Connections.
- If you use a temperature sensor with thermocouple inputs, make sure you use the compensation cable.
- Prevent temperature changes to the thermocouple connection terminal. Correct temperature measurement may not be possible if the thermocouple cold junction (LT's thermocouple compensation wiring to the connection terminal) experiences temperature changes.

WARNING

IMPROPER GROUNDING CAN CAUSE UNINTENDED EQUIPMENT OPERATION

- Use cables with insulated shielded jackets for analog I/O, fast I/O and communication signals.
- Ground shielded cables for analog I/O, fast I/O and communication signals at a single point ¹.
- Always comply with local wiring requirements regarding grounding of cable shields.

Failure to follow these instructions can result in death, serious injury, or equipment damage.

¹Multipoint grounding is permissible if connections are made to an equipotential ground plane dimensioned to help avoid shielded cable damage in the event of power system short circuit currents.

For more details, refer to Grounding Shielded Cables.

The wire sizes to use with the removable terminal blocks is 0.20 to 0.81 mm² (AWG 24 to 18).

DANGER

FIRE HAZARD

Use only the recommended wire sizes for I/O channels and power supplies.

Failure to follow these instructions will result in death or serious injury.

Terminal Block

Not plugging the terminal block into rear module correctly can cause an electric shock or unintended operation of the application and/or can damage the rear module.

DANGER

UNINTENDED EQUIPMENT OPERATION OR ELECTRIC SHOCK

Be sure to connect the terminal blocks to their designated location.

Failure to follow these instructions will result in death or serious injury.

NOTE: When installing the terminal blocks to the rear module, please keep the display module unmounted.

NOTE: To help prevent a terminal block from being inserted incorrectly, clearly and uniquely code and label each terminal block and rear module.

Avoid temperature changes on the thermocouple's connection terminal. Temperature measurements may not be accurate due to temperature changes in the cold junction (LT connection terminal for the thermocouple compensation cable).

The figure shows the labels on each terminal block:

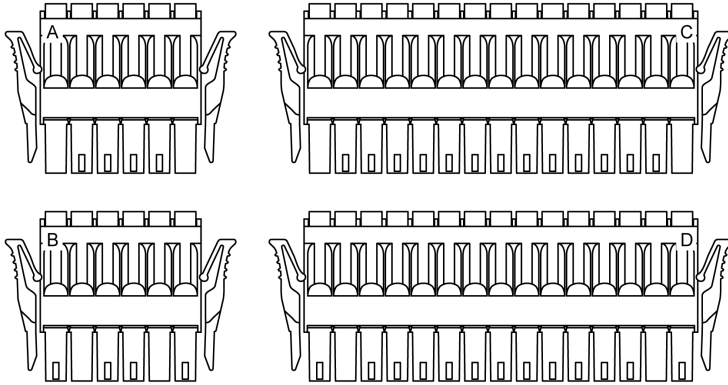

NOTE: Appearance of the connectors are the same but are different. Check the label and pin position of each connector before connecting.

Wiring to the DIO Terminal Block

CAUTION

EQUIPMENT DAMAGE

Be sure to remove the terminal blocks from the equipment prior to wiring.

Failure to follow these instructions can result in injury or equipment damage.

Screwdriver Required to Wire Terminal Blocks

Recommended type: 1891348-1 (Tyco electronics AMP)

If another manufacturer, be sure that the part has the following dimensions:

- point depth: 1.5 mm (0.06 in)
- point height: 2.4 mm (0.09 in)

Point shape must be DIN5264A and meet standard DN EN60900.

Also, the screwdriver tip must be flat, as indicated, to access the narrow hole of the terminal block:

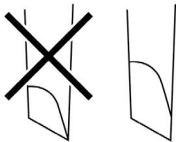

The terminal blocks are a spring clamp type.

Procedure

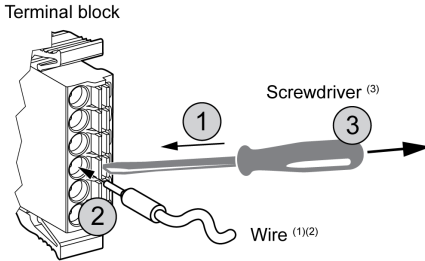

Use the following procedure to connect the wires to the terminal blocks:

Step	Action
1	Insert the screwdriver into the square-shaped hole. This will open the wire's round-shaped hole.
2	Hold the screwdriver and insert the wire into the wire's round-shaped hole.
3	Take out the screwdriver from the square-shaped hole. The round-shaped hole will then close, and the wire will be held securely in place.

NOTE: To remove the wire, reinsert the screwdriver into the square-shaped hole and when the wire's spring clamp releases, pull out the wire.

(1) Wire should be $0.20...0.81 \text{ mm}^2$ (AWG 24...18), with the end twisted. Applicable wire style are UL1015 and UL1007.

(2) Strip 7.0 mm (*0.28 in*) of jacket from the wire. Strip only the amount of jacket required. If too much jacket is removed, the ends may short against each other or against the terminals, which can create an electric short. If not enough jacket is removed, the wire may not make sufficient contact with the terminal.

Insert each wire completely into its opening. Improper insertion can lead to a loss of unit power or short circuit, either against the wire filaments or against the terminals, or to over heating of the wire and terminal.

(3) Do not rotate the point of the screwdriver inside the square-shaped opening. It may damage the equipment.

⚠ WARNING

IMPROPER WIRING PRACTICES CAN MAKE EQUIPMENT INOPERABLE

- Use only the specified wire sizes for I/O channels and power supplies.
- Prepare wires and make connections as specified in this documentation.
- Do not connect more than one wire per terminal block connector.

Failure to follow these instructions can result in death, serious injury, or equipment damage.

Terminal Blocks

The figure shows the terminal blocks:

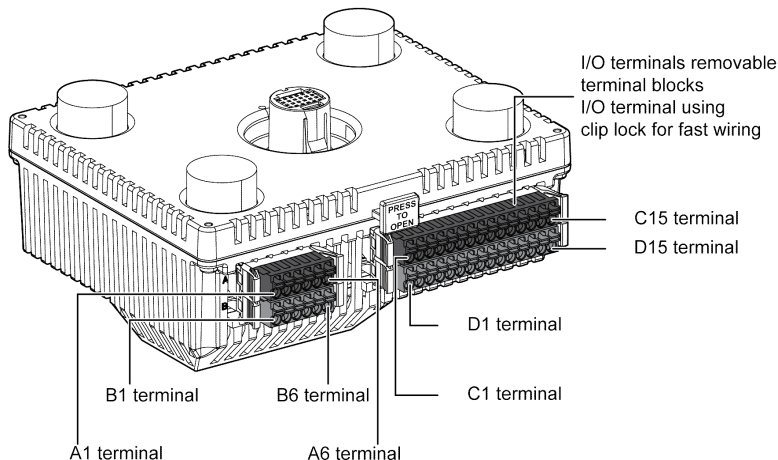

The figure shows the pin assignment of the LT-4201TM (Modular Type DIO), LT-4301TM (Modular Type DIO) and LT-4000M (Modular Type DIO) terminal blocks:

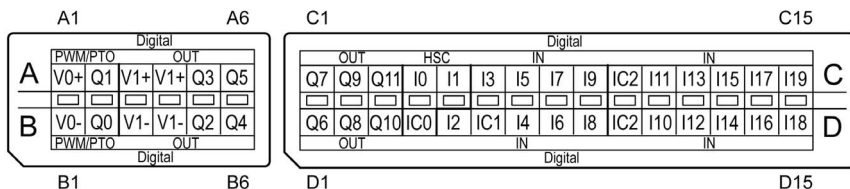

NOTE: Confirm the connector label ABCD and the stamp ABCD on the unit before wiring.

The figure shows the groups and the signal names of the terminal blocks:

Pin Arrangement	Group	Pin	Signal Name	Group	Pin	Signal Name
	Fast Output	A1	V0+	Fast Output	B1	V0-
		A2	Q1		B2	Q0
	Standard Output	A3	V1+	Standard Output	B3	V1-
		A4	V1+		B4	V1-
		A5	Q3		B5	Q2
		A6	Q5		B6	Q4

The figure shows the groups and the signal names of the terminal blocks:

Pin Arrangement	Group	Pin	Signal Name	Group	Pin	Signal Name
	Standard Output	C1	Q7	Standard Output	D1	Q6
		C2	Q9		D2	Q8
		C3	Q11		D3	Q10
	Fast Input/Standard Input	C4	I0	Fast Input/Standard Input	D4	IC0
		C5	I1		Standard Input	D5
	Standard Input	C6	I3	D6		IC1
		C7	I5	D7		I4
		C8	I7	D8		I6
		C9	I9	D9		I8
		C10	IC2	D10		IC2
		C11	I11	D11		I10
		C12	I13	D12		I12
		C13	I15	D13		I14
		C14	I17	D14		I16
		C15	I19	D15	I18	

The figure shows the pin assignment of the LT-4201TM (Modular Type Analog), LT-4301TM (Modular Type Analog) and LT-4000M (Modular Type Analog) terminal blocks:

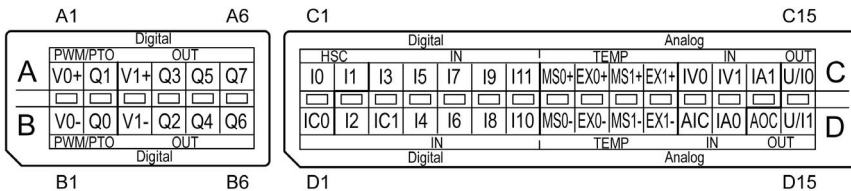

NOTE: Confirm the connector label ABCD and the stamp ABCD on the unit before wiring.

The figure shows the group and the signal names of the terminal blocks:

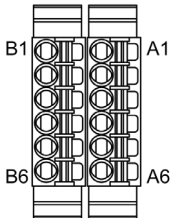
Pin Arrangement	Group	Pin	Signal Name	Group	Pin	Signal Name
	Fast Output	A1	V0+	Fast Output	B1	V0-
		A2	Q1		B2	Q0
	Standard Output	A3	V1+	Standard Output	B3	V1-
		A4	Q3		B4	Q2
		A5	Q5		B5	Q4
		A6	Q7		B6	Q6

The figure shows the group and the signal names of the terminal blocks:

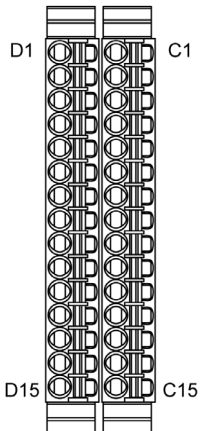
Pin Arrangement	Group	Pin	Signal Name	Group	Pin	Signal Name
	Fast Input/Standard Input	C1	I0	Fast Input/Standard Input	D1	IC0
		C2	I1		Standard Input	D2
	Standard Input	C3	I3	D3		IC1
		C4	I5	D4		I4
		C5	I7	D5		I6
		C6	I9	D6		I8
		C7	I11	D7	I10	
	Temperature Input	C8	MS0+	Temperature Input	D8	MS0-
		C9	EX0+		D9	EX0-
		C10	MS1+		D10	MS1-
		C11	EX1+		D11	EX1-
	Analog Input	C12	IV0	Analog Input	D12	AIC
		C13	IV1		D13	IA0
		C14	IA1	Analog Output	D14	AOC
	Analog Output	C15	U/I0		D15	U/I1

Connecting the Power Cord

Follow these instructions when supplying power to the unit:

- When the frame ground (FG) terminal is connected, verify the wire is grounded. Not grounding the unit can result in excessive Electromagnetic Interference (EMI). Grounding is required to meet EMC level immunity.
- The shield ground (SG) and FG terminals are connected internally in the unit.
- Remove power before wiring to the power terminals of the unit.
- The unit uses 24 Vdc power. Using any other level of power can damage both the power supply and the unit.
- Since the unit is not equipped with a power switch, connect a power switch to the unit's power supply.
- Use copper wire rated for 75°C (167°F) or higher.

Power Cord Preparation

Before using your power cord:

- Verify that the ground wire is the same gauge or heavier than the power wires.
- Do not use aluminum wires for the power supply's power cord.
- If the conductor end (individual) wires are not twisted correctly, the end wires may either short loop to each other or against an electrode. To avoid this, use D25CE/AZ5CE cable ends.
- Use wires that are 0.75 to 2.5 mm² (18 to 12 AWG) for the power cord, and twist the wire ends before attaching the terminals.
- The conductor type is solid or stranded wire.
- To reduce electromagnetic noise, make the power cord as short as possible.

Power Plug Illustration

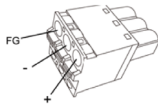

Connection	Wire
+	24 Vdc
-	0 Vdc
FG	Grounded terminal connected to the unit chassis

Connecting the Power Cord

The table explains how to connect the power plug:

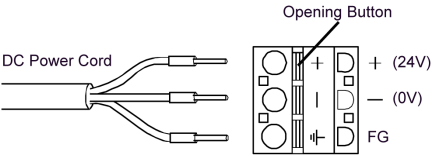
Step	Action
1	Confirm the power cord is not connected to the power supply.
2	Check the rated voltage and remove the "DC24V" sticker on the DC power supply connector.
3	Remove 10 mm (0.39 in.) of the vinyl membrane off the ends of the power code wires.
4	If using stranded wire, twist the ends. Tinning the ends with solder reduces risk of fraying and ensures good electrical transfer.
5	Push the Opening button with a small and flat screwdriver to open the desired pin hole.
6	<p>Insert each pin terminal into its corresponding hole. Release the Opening button to clamp the pin in place.</p> 
7	After inserting all three pins, insert the power plug into the power connector on the LT.

NOTE:

- Do not solder the wire directly to the power receptacle pin.
- The power supply cord must meet the specification shown above. Twist the power cords together, up to the power plug, for EMC compliance.

Precautions:

- Connect the power cord to the power connector on the rear module using the power plug.
- Use DC input with a Class 2 power supply.
- Do not bundle the power supply cord with, or keep close to, main circuit lines (high voltage, high current), or I/O signal lines.
- Connect a lightning surge absorber to handle power surges.

Excessive stress on the power connection or attempting to install the rear module with the power cables connected may disconnect, or cause damage, to the power connections. This can cause short circuits, fire, or unintended equipment operation.

⚠ WARNING

SHORT CIRCUITS, FIRE, OR UNINTENDED EQUIPMENT OPERATION

- Securely attach power cables to the panel or cabinet.
- Secure the power plug of the rear module.
- Install and fasten the rear module on the installation panel or cabinet prior to connecting power supply and communication lines.

Failure to follow these instructions can result in death, serious injury, or equipment damage.

Power Supply Connections

For maintenance purpose, use the following connection diagram to set up your power supply connections. However, when terminals A2 and B2 (signal name: Q1, Q0) are wired to external I/O, use the same power source for external I/O and the LT:

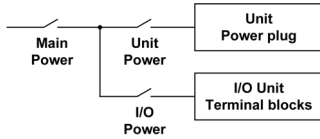

When wiring terminals A2 and B2 (signal name: Q1, Q0) to external I/O:

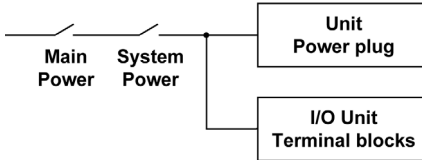

NOTE:

- When connector A2 and B2 (Signal Name: Q1, Q0) are wired to external I/O, turn on the LT before turning on the external device. Otherwise the wrong signal for Pulse Output, PWM Output and High-speed Counter (Synchronize Output) will be output. When transferring a program that turns off or resets the LT, first turn off the external device. When using a system with multiple power supplies, please note there is also a power supply in the external device.

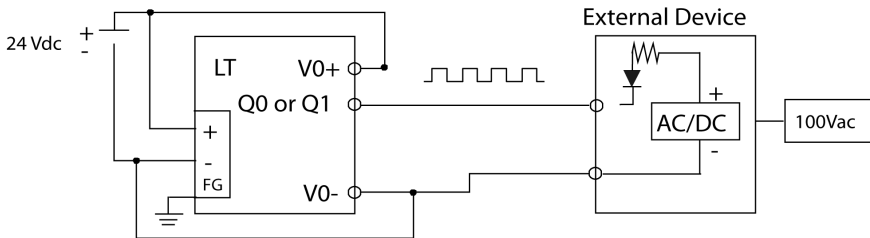

- Ground the surge absorber separately from the rear module.
- Select a surge absorber that has a maximum circuit voltage greater than the peak voltage of the power supply.

The diagram illustrates a lightning surge absorber connection:

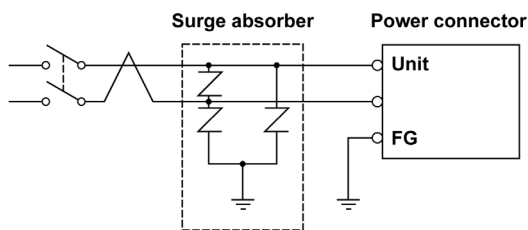

Grounding the System

To minimize the effects of electromagnetic interference, cables carrying the fast I/O, analog I/O, and Serial communication signals must be shielded.

⚠ WARNING

IMPROPER GROUNDING CAN CAUSE UNINTENDED EQUIPMENT OPERATION

- Use cables with insulated shielded jackets for analog I/O, fast I/O and communication signals.
- Ground shielded cables for analog I/O, fast I/O and communication signals at a single point ¹.
- Always comply with local wiring requirements regarding grounding of cable shields.

Failure to follow these instructions can result in death, serious injury, or equipment damage.

¹To avoid damage to the shielded cable when there is a short circuit in the power line, set up a multi-point frame ground (FG) each with the same electric potential.

The use of shielded cables requires compliance with the following wiring rules:

- When there is no protective earth ground, you can use metal conduit or cable duct shield as a part of the protective earth ground. The functional ground (FE) shield must attenuate electromagnetic interference and must be shielded the length of the cable. If the purpose is for both functional and protective grounding, as is often the case for communication cables, the cable must have continuous shielding.
- Wherever possible, keep cables carrying one type of signal separate from the cables carrying other types of signals or power.

Protective Earth Ground on the Backplane

For protective grounding, connect braided copper cable (that can withstand the maximum voltage/current allowed by the system) to the conductive backplane.

Functional Ground on the DIN Rail

The DIN rail for your LT system is common with the functional ground plane and must be mounted on a conductive backplane.

WARNING

UNINTENDED EQUIPMENT OPERATION

When connecting DIN rails, connect the DIN rails to functional ground (FE).

Failure to follow these instructions can result in death, serious injury, or equipment damage.

Shielded Cable Connections

Cables carrying the fast I/O, analog I/O, and Serial communication signals must be shielded. The shielding must be securely connected to ground. The fast I/O and analog I/O shields may be connected either to the functional ground (FE) or to the protective earth ground (PE) of your LT.

WARNING

ACCIDENTAL DISCONNECTION FROM PROTECTIVE GROUND (PE)

- Do not use the grounding bar to provide a protective earth ground (PE).
- Use the grounding bar only to provide a functional ground (FE).

Failure to follow these instructions can result in death, serious injury, or equipment damage.

DANGER

HAZARD OF ELECTRIC SHOCK

Make sure that CANopen and Modbus cables are securely connected to the protective earth ground (PE).

Failure to follow these instructions will result in death or serious injury.

NOTE: The functional ground of the Ethernet connection is internal.

Protective Earth Ground (PE) Cable Shielding

The following shows the steps when using shield cables for grounding the LT power supply, Standard I/O, High-speed I/O, Analog I/O, Temperature Input, Communication cable so on.

Step	Description	
1	Strip the shielding for a length of 15 mm (0.59 in.).	
2	Use the metal grounding clamp(2) to attach the cable to the backplane plate (1) as close as possible to the LT.	

NOTE: The shielding must be clamped securely to the conductive backplane to ensure good contact.

Exclusive Grounding

Connect the frame ground (FG) terminal on the power plug to an exclusive ground. When supplying power to the LT unit, be sure to separate the input, output and power lines, as shown:

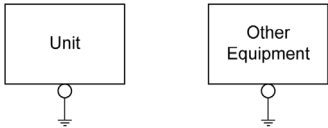

Common Grounding

If exclusive grounding is not possible, use a common grounding point. Use grounding resistance of $10\ \Omega$ or less, wire thickness of 2.6 mm or more, or your country's applicable standard for the grounding point.

Precautions:

- Do not use common grounding, since it can lead to accidents and machine breakdown.
- If the equipment does not function properly when grounded, disconnect the ground wire from the FG terminal.

If exclusive grounding is not possible, use a common connection point.

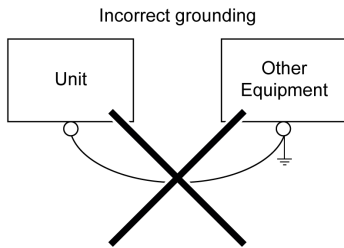
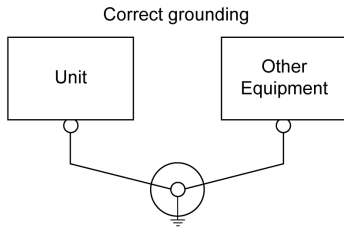

Grounding Procedure

Step	Action
1	Check that the grounding resistance is less than $100\ \Omega$. (Grounding resistance of $100\ \Omega$ or less, wire thickness of 1.6 mm or more, or your country's applicable standard.)
2	Create the connection point as close to the unit as possible, and make the wire as short as possible. When using a long grounding wire, replace the thin wire with a thicker wire, and place it in a duct.

NOTE: FG and SG terminals are internally connected in the LT. When connecting an external device to the LT using the SG terminal, be sure to check that no short-circuit loop is created when you setup the system.

Communication Interfaces

USB Device

When using a USB device, you can attach a USB holder to the USB interface on the side of the unit to prevent the USB cable from being disconnected.

Attaching the USB Type A Holder

Hook the upper pick of the USB holder to the attachment hole and insert the lower pick to fix the USB holder in place.

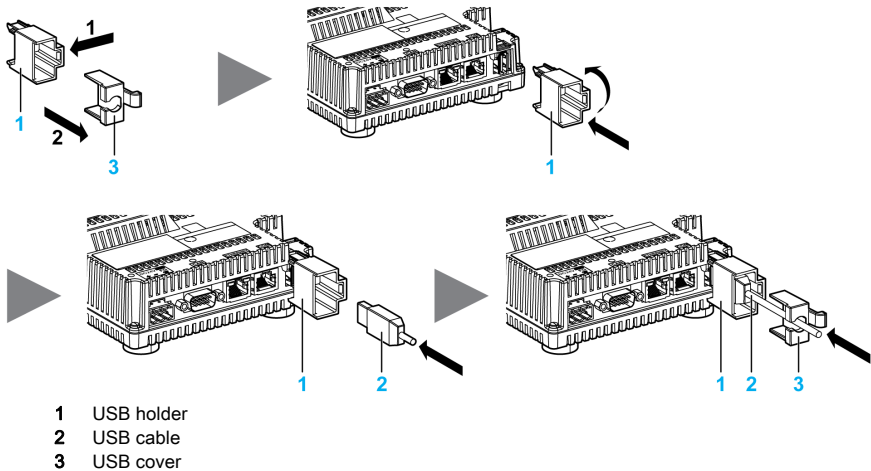

Removing the USB Type A Holder

Push down the tab of the USB holder and then remove the USB cover.

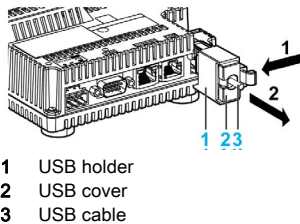

Attaching and Removing the USB Mini-B Holder

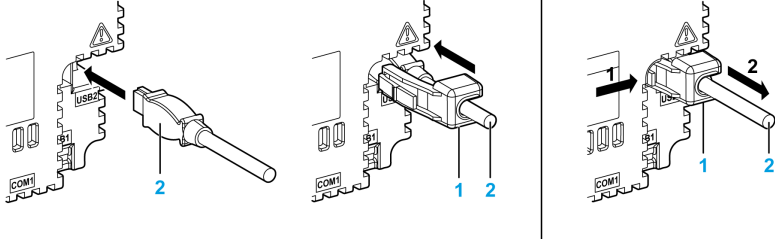

- 1 USB holder
- 2 USB cable

NOTE: The USB holder is supplied in the accessory kit PFXZGMAK1 (sold separately).

Ethernet Interface

Do not confuse the RJ45 Ethernet connector with the RJ45 interface.

NOTE: Ethernet networks should be installed by a trained and qualified person. When you use a 1:1 connection to connect to a device such as PC, you can use a cross cable, but we recommend using a hub.

Ethernet Interface Pin Assignment

The figure shows the RJ45 Ethernet connector pin assignment:

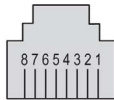

The table describes the RJ45 Ethernet connector pins:

Pin	Signal
1	TD+
2	TD-
3	RD+
4	–
5	–
6	RD-
7	–
8	–

NOTE: The LT supports the MDI/MDIX auto-crossover cable function. You do not have to use special Ethernet crossover cables to connect devices directly to this interface (connections without an Ethernet hub or switch).

Serial Interface Pin Assignment COM1

The figure shows the pins of the RJ45 connector when viewed from LT:



The table describes the pin assignment of the RJ45 connector:

Pin	RS-232C	RS-485	Description
1	RxD	N.C.	Received data (RS-232C)
2	TxD	N.C.	Transmitted data (RS-232C)
3	N.C.	N.C.	Not connected
4	N.C.	D1+	Differential data (RS-485)
5	N.C.	D0-	Differential data (RS-485)
6	N.C.	N.C.	Not connected
7	N.C.	N.C.	Not connected
8	GND	GND	Signal ground

WARNING

UNINTENDED EQUIPMENT OPERATION

Do not connect wires to unused terminals or terminals marked "Not Connected (N.C.)".

Failure to follow these instructions can result in death, serious injury, or equipment damage.

CANopen Capabilities

The LT CANopen master has the following features:

Maximum number of slaves on the bus	16 CANopen slave devices
Maximum length of CANopen fieldbus cables	According to the CAN specification (see cable length and transmission speed).
Maximum number of PDOs managed by the master	32 TPDOs + 32 RPDOs

For each additional CANopen slave:

- The application size increases by an average of 10 KB that can result in a memory size overload.
- The configuration initialization time at startup increases, which can lead to a watchdog condition.

Although LT does not restrict you from doing so, we recommend that you not exceed 16 CANopen slave modules (and/or 32 TPDOs and 32 RPDOs) for sufficient performance tolerance and to avoid performance degradation.

⚠ WARNING

UNINTENDED EQUIPMENT OPERATION

Do not connect more than 16 CANopen slave devices to the LT.

Failure to follow these instructions can result in death, serious injury, or equipment damage.

NOTICE

DEGRADATION OF PERFORMANCE

Do not exceed 32 TPDOs and 32 RPDOs for the LT.

Failure to follow these instructions can result in equipment damage.

CANopen Interface Pin Assignment

The graphic describes the pins of the CANopen interface:

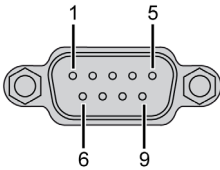

The table describes the pins of the CANopen interface:

Pin	Signal	Description
1	N.C.	Reserved
2	CAN_L	CAN_L bus line (Low)
3	CAN_GND	CAN 0 Vdc
4	N.C.	Reserved
5	CAN_SHLD	N.C.
6	GND	0 Vdc
7	CAN_H	CAN_H bus line (High)
8	N.C.	Reserved
9	N.C.	Reserved

The shield is connected to pin 6, the 0 Vdc pin.

NOTE: Pin 9 is not connected internally. The controller does not provide power on CAN_V+.

WARNING

UNINTENDED EQUIPMENT OPERATION

Do not connect wires to unused terminals or terminals marked “Not Connected (N.C.)”.

Failure to follow these instructions can result in death, serious injury, or equipment damage.

System LED Display

NOTE:

- Ethernet LEDs are mounted next to the I/O terminal block.
- CANopen LED is mounted alongside the cover.

System LED Description

The table describes the status LEDs operations:

Label	Description	LED		
		Color	Status	Description
CAN STS	CANopen status	OFF	No CANopen configured	CANopen is not active in the application.
		Single flash red / with green ON	Acceptable detected error limit threshold has been reached	The controller has detected that the maximum number of error frames has been reached or exceeded.
		Double flash red / with green ON	Node Guarding or Heartbeat event	The controller has detected either a Node Guarding or Heartbeat exception for the CANopen master or slave device.
		Red ON	Bus off	The CANopen bus is stopped.
		Green ON	The CANopen bus is operational.	
IND1	Ethernet status	Green	Off	No connection or subsequent transmission failure.
			On	Data transmission is available.
IND2	Ethernet activity	Green	Off	No data transmission.
			On	Data transmission is occurring.

