

27 | Recording and Playing Video

This chapter explains how to use GP-Pro EX to record and play videos, how to display video from video modules, DVI units, and image units, and how to work with other useful features. Please start by reading "27.1 Settings Menu" (page 27-2), and then turn to the corresponding page.

27.1	Settings Menu	27-2
27.2	Displaying Video Camera Output.....	27-8
27.3	Recording Video.....	27-13
27.4	Recording Video Before and After a Malfunction	27-21
27.5	Playing Movies	27-26
27.6	Displaying Multiple Video Camera Outputs Simultaneously	27-52
27.7	Displaying PC Screen	27-61
27.8	Saving Video Output as Still Images	27-67
27.9	Settings Guide.....	27-75
27.10	Restrictions	27-145

27.1 Settings Menu

A select few models support the features introduced in this chapter. Check whether your model supports the features before changing any settings.

☞ "1.3 Supported Features" (page 1-5)

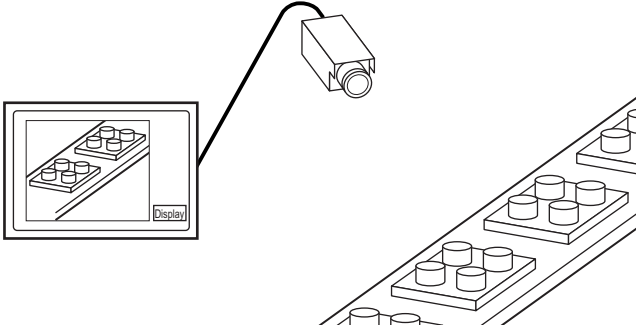
Displaying Video Camera Output	
<p>Displays real-time video from a camera connected to the GP.</p> 	<ul style="list-style-type: none"> ☞ Setup Procedure (page 27-9) ☞ Introduction (page 27-8)

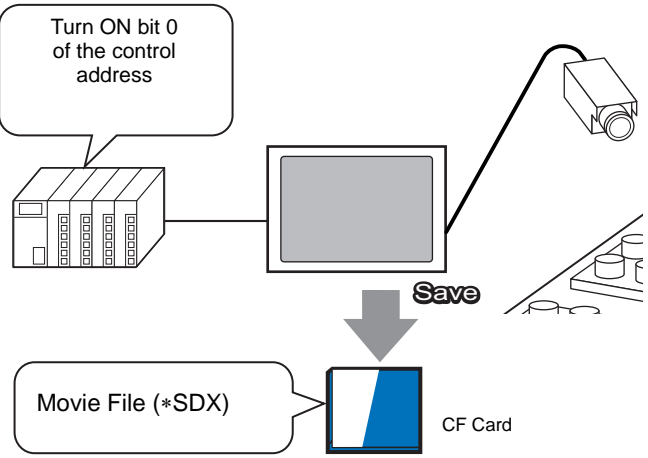
Recording Video	
<p>Saves the video signal to a CF Card or FTP server as movie files.</p>  <p>Turn ON bit 0 of the control address</p> <p>Movie File (*SDX)</p> <p>CF Card</p>	<ul style="list-style-type: none"> ☞ Setup Procedure (page 27-14) ☞ Introduction (page 27-13)

Recording Video Before and After a Malfunction

Automatically saves the video signal before and after a malfunction.

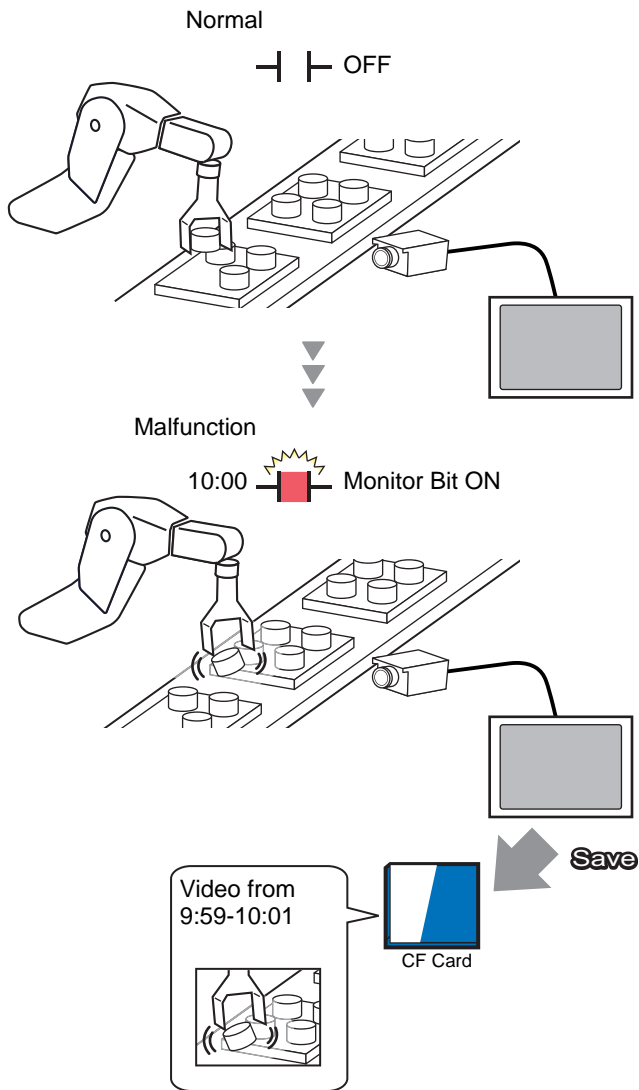

- Setup Procedure (page 27-22)
- Introduction (page 27-21)

Playing Movies

Plays the movies in the specified order.

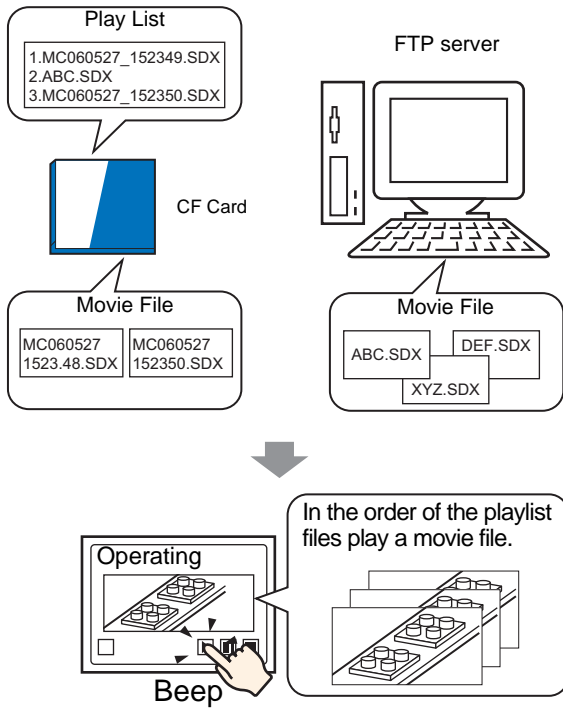

- ☞ Setup Procedure (page 27-27)
- ☞ Introduction (page 27-26)

Playing Movies

Plays the movie you want to see when you want to see it.

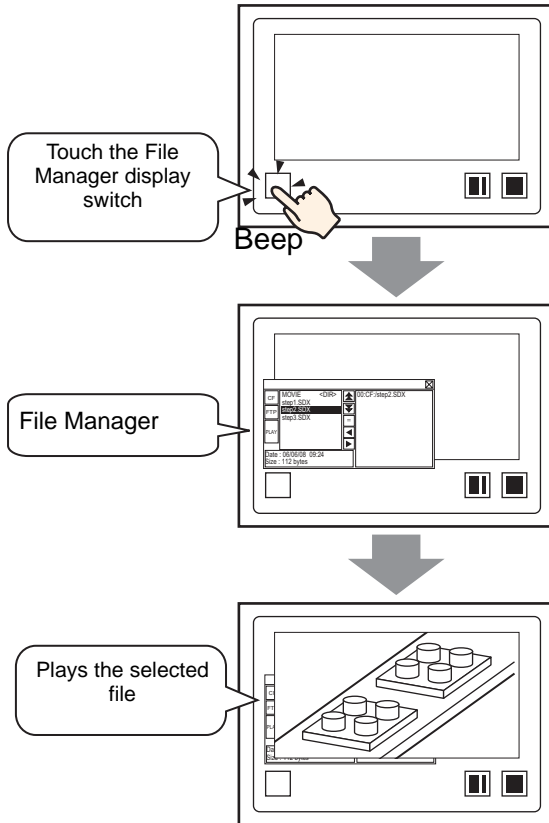

- 👉 Setup Procedure (page 27-27)
- 👉 Introduction (page 27-26)

Displaying Multiple Video Camera Outputs Simultaneously

Displays video from cameras connected to a VM unit in real time.

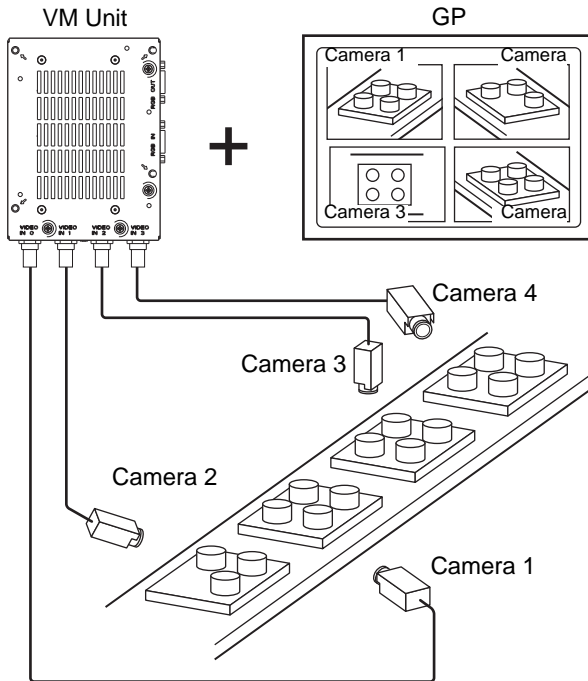

- ☞ Setup Procedure (page 27-53)
- ☞ Introduction (page 27-52)

Displaying PC Screen

GP can be used as a PC monitor.

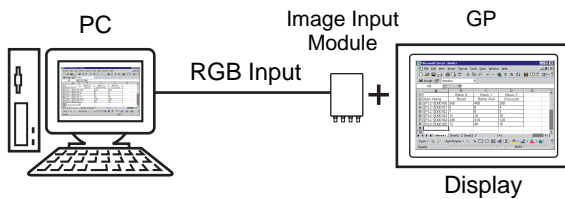

- ☞ Setup Procedure (page 27-62)
- ☞ Introduction (page 27-61)

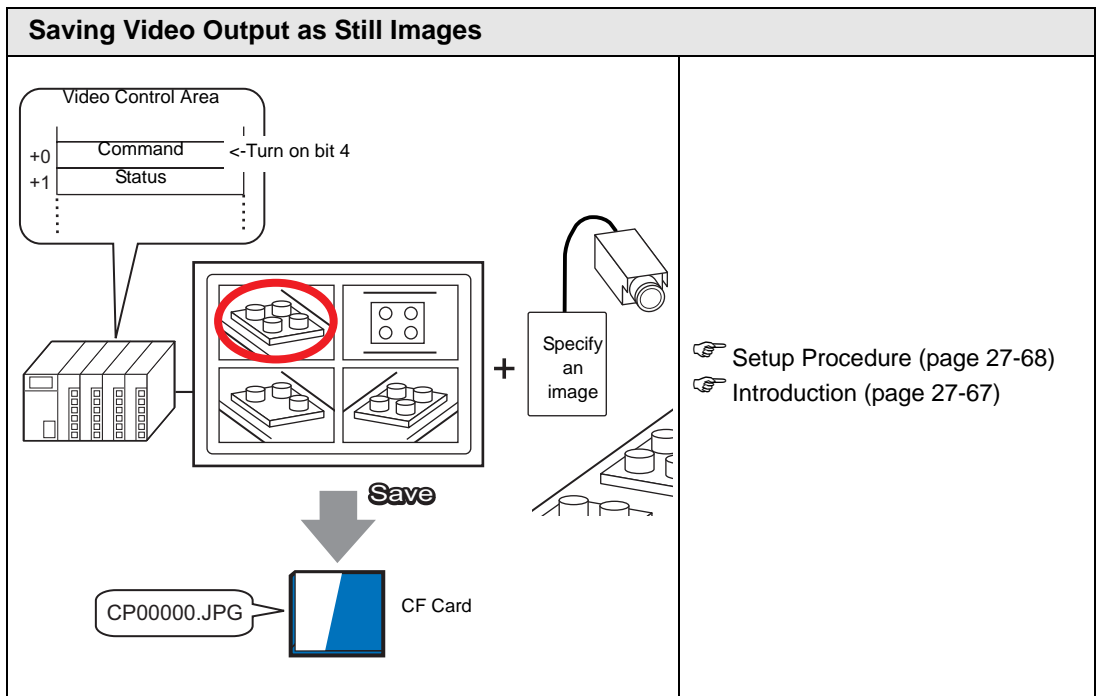

27.2 Displaying Video Camera Output

27.2.1 Introduction

With AGP-3450T/3550T/3560T/3650T/3750T models, you can display streaming video from a video camera connected to the GP. This feature is useful for monitoring the status of a factory line and ensuring safety.

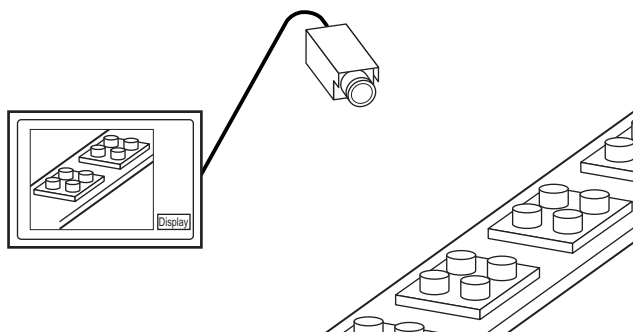

NOTE

- With AGP-3550T/3560T/3650T, you can also display video using the optional video module unit.
 ☞ "27.9.6 [Image Input Module] Settings Guide" (page 27-129)
- Only images are displayed. In order to display images with sound, you must first record a movie and then play it back.
 ☞ "27.3 Recording Video" (page 27-13)

27.2.2 Setup Procedure

NOTE

- Please refer to the Settings Guide for details.
 - ☞ "27.9.1 [Video/Movie] Settings Guide" (page 27-75)
 - ☞ "27.9.4 [Movie Player] Settings Guide" (page 27-99)
- For details of the part placement method and the address, shape, color, and label setting method, refer to the "Part Editing Procedure".
 - ☞ "8.6.1 Editing Parts" (page 8-44)

Displaying video from a video camera on the GP screen in real time.

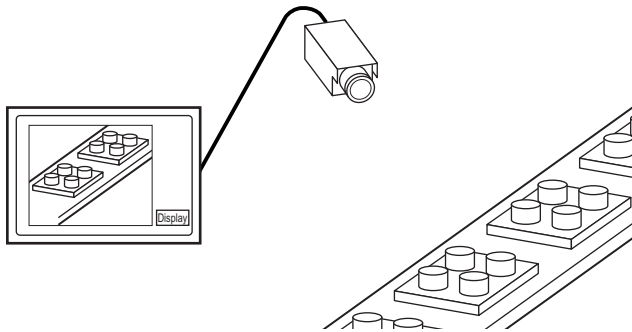

1 In [System Settings], click [Video/Movie].

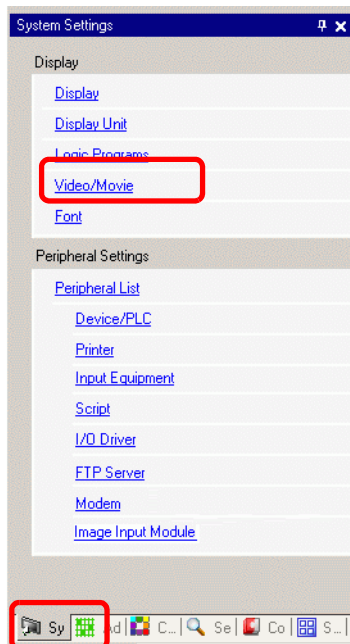

NOTE

- If the [System Settings] tab is not displayed in the workspace, on the [View (V)] menu, point to [Workspace (W)], and then click [System Settings (S)].

- 2 From [Signal], select [NTSC]. In [Signal] select the video signal supported in your region: [NTSC] or [PAL].

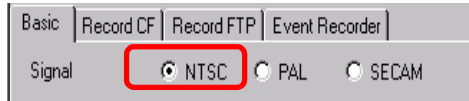

- 3 In the [Screen List] window, open the base screen where you want to display the video. On the [Parts (P)] menu, click [Movie Player (O)], or click  and place a movie player on the screen.

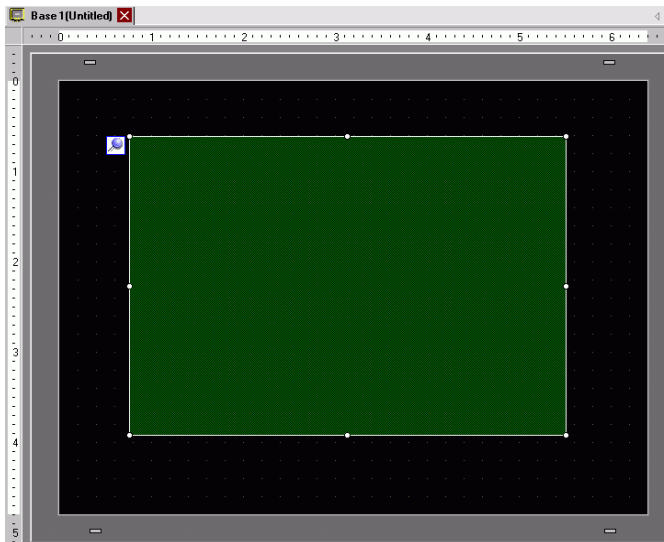

- 4 Double-click the movie player. The following dialog box appears.
In the [Display Size] area select [1/4].

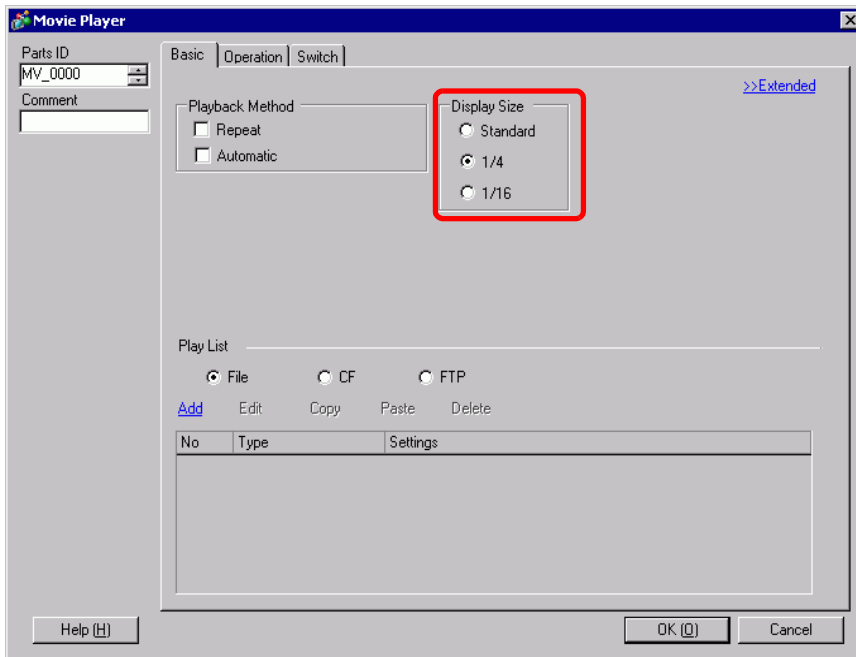

NOTE

- If the selected [Display Size] is larger than the size of the GP screen or the movie player, the entire image is not displayed. If you want to display the entire image, set the [Display Size] smaller than the size of the movie player.

- 5 Click the [Switch] tab. [Switch Layout] options, select the [Video] check box. In the [Details] list, select [Video ON/OFF].

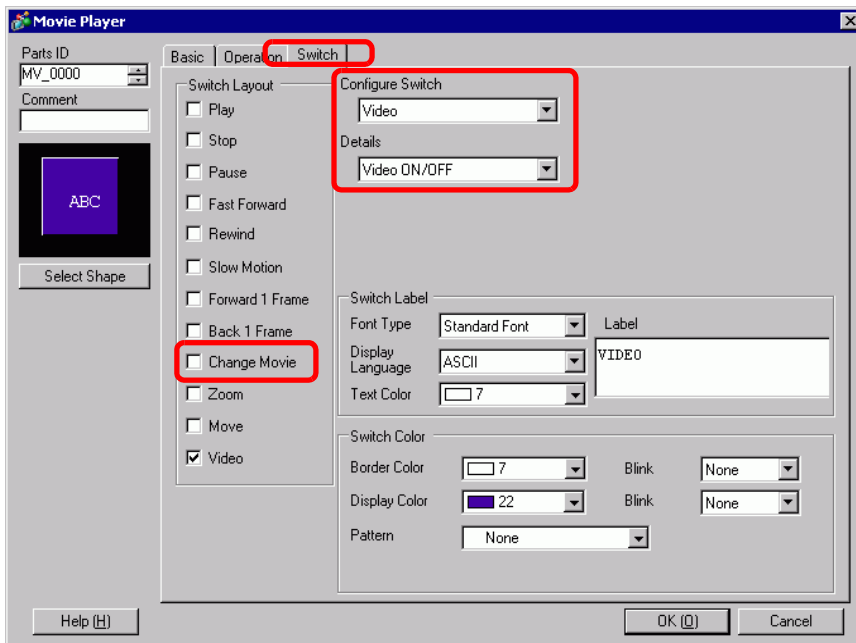

- 6 Click [Select Shape] to select the shape of the switch and specify the label and color as desired, and then click [OK].

NOTE

- Depending on the shape of the switch, you may not be able to change the color.
 - When you select a switch and press the [F2] key you can directly edit the label text.
-

27.3 Recording Video

27.3.1 Introduction

AGP-3450T/3550T/3560T/3560T/3750T models can save the video signal from the GP as movie files with audio.

Turn ON bit 0 of the specified control address to start recording the image on the CF Card (or FTP server). The video signal is saved in a movie file format (.sdx) unique to GP.

■ Saving on a CF Card

In the "Movie" folder on the CF Card, the movie file is saved under the specified folder name and file name (first 2 letters). Each file can save a movie of up to 512 MB. Each folder can save a maximum of 100 files.

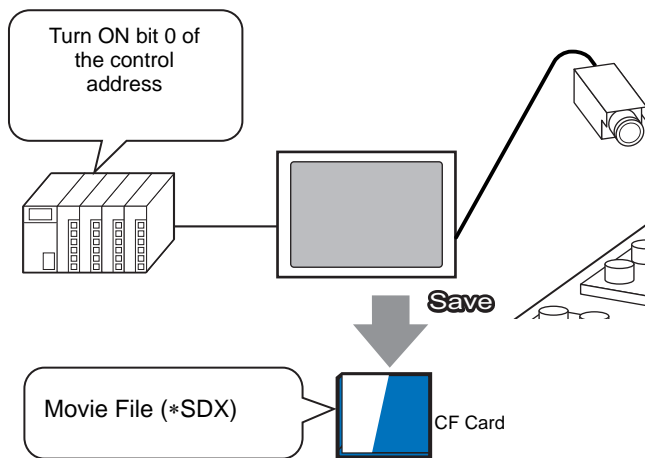

■ Saving on an FTP Server

On a registered FTP server, a movie file is saved under the specified folder name and file name (first 2 letters). Each file can save a movie up to 2048 MB.

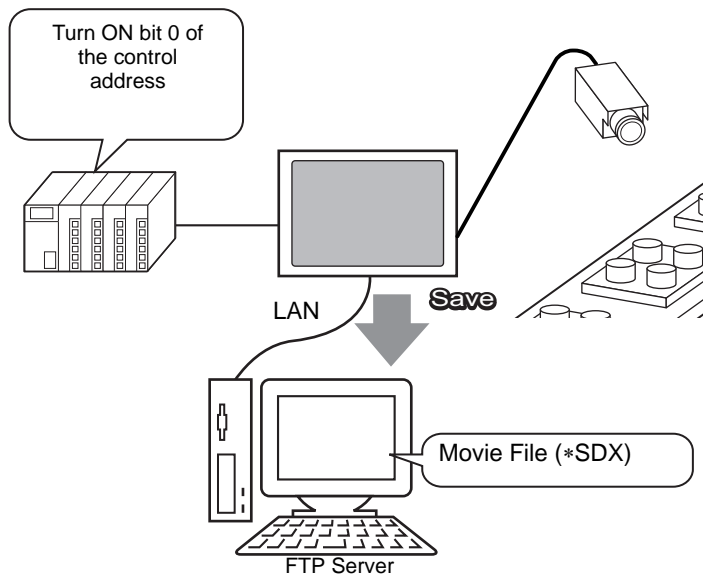

27.3.2 Setup Procedure

■ Saving a Movie File to the CF Card

NOTE

- Please refer to the Settings Guide for details.
 ☞ "27.9.1 [Video/Movie] Settings Guide" (page 27-75)

Turn ON bit 0 of the control address to begin saving the movie file to the CF card.

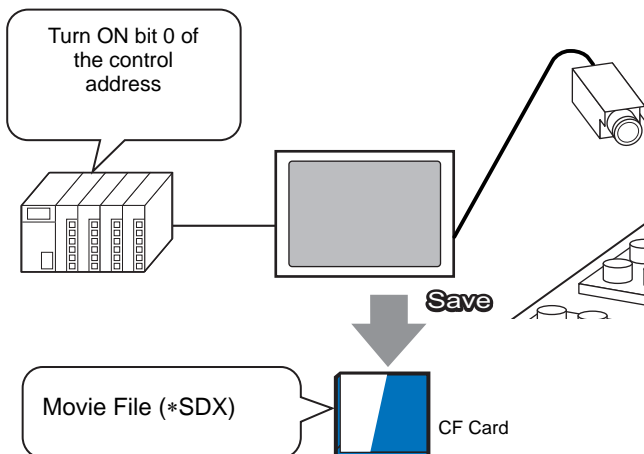

1 In [System Settings], click [Video/Movie].

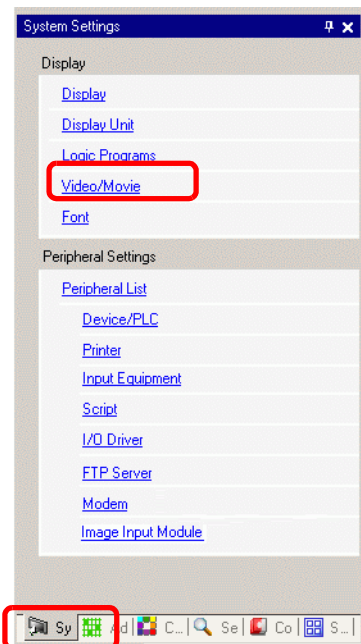
NOTE

- If the [System Settings] tab is not displayed in the workspace, on the [View (V)] menu, point to [Workspace (W)], and then click [System Settings (S)].

2 For the [Signal], select [NTSC]. Under [Record Size], select [QVGA(384kbps)].

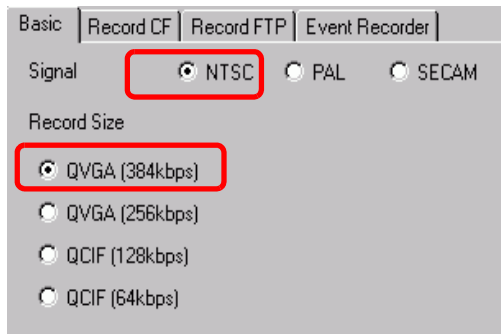

3 [Click the [Record CF] tab and select the [Record CF] check box.



4 Specify the [File Size] and [Number of Files] to be saved.

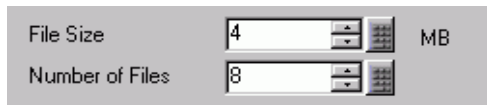

NOTE

- Any pictures that exceed the specified file size are automatically saved in the next file. The file name is created based on the time stamp when the save operation begins (year, month, date, hours, minutes, seconds).

5 In the [User Set String] area select [Direct] and enter two single-byte characters (for example, MC). This string is the folder name and the first two characters of the file name for the saved movie.

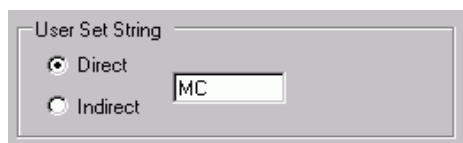

NOTE

- The movie is saved with the file name beginning with the user-defined string (maximum two characters) + timestamp (year, month, day, hours, minutes, seconds) + file extension .SDX.
For example, if a folder and file are saved at 15:23'26" on May 27, 2006, the file name will be "MC060527_152346.SDX".
- If [Indirect] is selected, you must store the user set string with PLC before saving to the CF card. To specify the number indirectly, use three Words from the specified address.
- If [User Set String] is not set, the folder will be named "NONAME".

6 In [Control Word Address], specify a Word address (for example, D100) to control saving.

Click the icon to display an address input keypad.

Select the device "D" and enter "100" in the address, then press the "Ent" key.

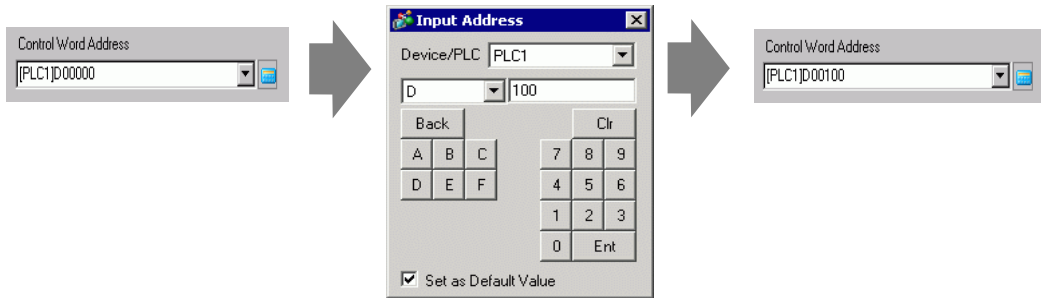

Settings for saving movies to a CF card have been successfully completed.

NOTE

- The video signal can be displayed while it is being recorded.
- Stored movie files cannot be played while a video signal is being recorded.

◆ Operating Procedure

Use three sequential Words from the specified address to control saving.

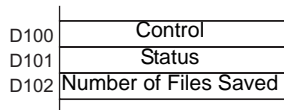

- 1 Turn ON bit 0 of D100 to start recording (saving to CF Card).
Bit 0 of status address (D101) turns ON while saving.
- 2 Turn OFF bit 0 of D100 to stop recording. "1" is added to D102.

NOTE

- You cannot save more movie files in the folder than the number specified in [Number of Files].

■ Saving a Movie File to the FTP Server

NOTE

- In order to save the files on an FTP server, you must have an FTP (File Transfer Protocol) server set up on the network in advance.
- Please refer to the Settings Guide for details.
 - ☞ "27.9.2 [FTP Server] Settings Guide" (page 27-95)
 - ☞ "27.9.1 [Video/Movie] Settings Guide" (page 27-75)

Turn ON bit 0 of the control address to start saving a movie file on the registered FTP server.

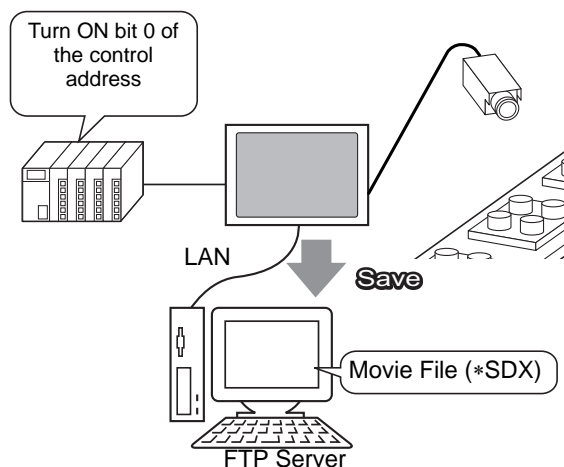

1 In the [System Settings], click [FTP Server].

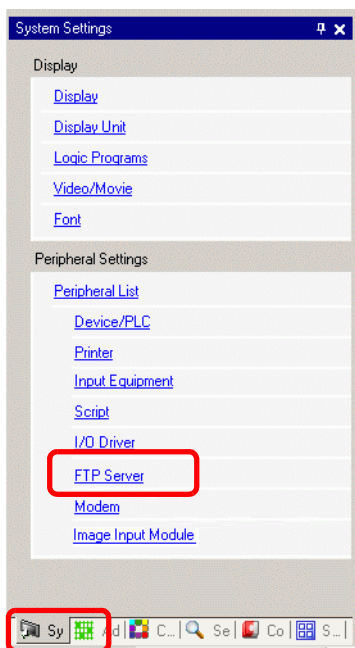

NOTE

- If the [System Settings] tab is not displayed in the workspace, on the [View (V)] menu, point to [Workspace (W)], and then click [System Settings (S)].

- Click [New] to open the [FTP Server] dialog box. Enter the FTP server information (registry number, IP address, password, etc.) to save the movie file. Click [OK] to exit the FTP server registration.

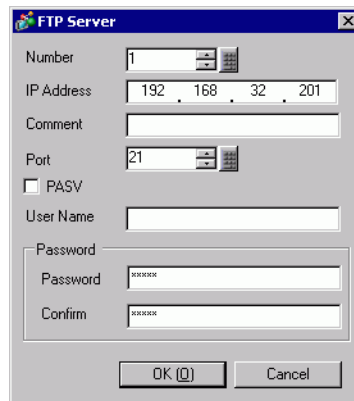
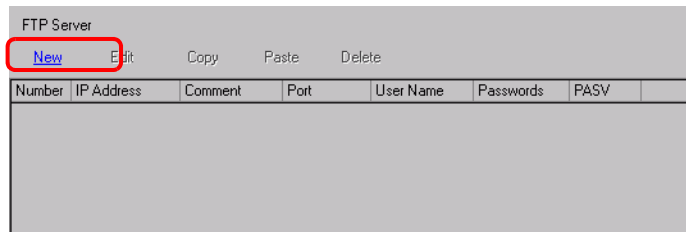

- In [System Settings], click [Video/Movie].



- Select [Video Input] and [Record Size].

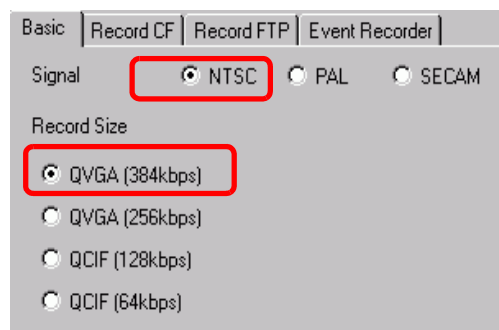

5 Click the [Record FTP] tab and select the [Record to FTP] check box.

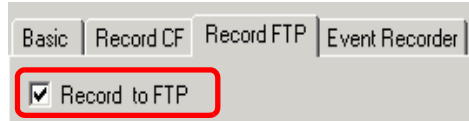

6 In [FTP Server], select [Direct] then select the registration number of the FTP server registered in step 2.

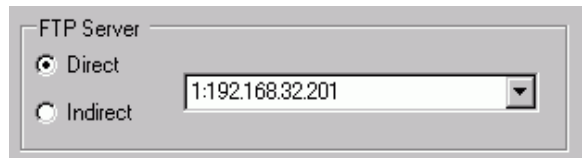

7 In [File Size], set the maximum file size for the video.



NOTE

- Any pictures that exceed the specified file size are automatically saved in the next file. The file name is created based on the time stamp when the save operation begins (year, month, date, hours, minutes, seconds).

8 In the [User Set String] area, select [Direct] and enter two single-byte characters (for example, MC). This string is the folder name and the first two characters of the file name under which the movie is saved.

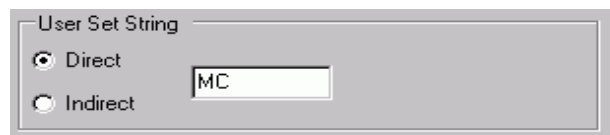

NOTE

- The movie is saved with the file name beginning with the user-defined string (maximum two characters) + time stamp + file extension .sdx. For example, if a folder and file are saved at 15:23'26" on May 27, 2006, the file name will be "MC060527_152346.SDX".
- If [Indirect] is selected, you must specify the server registry number with PLC before saving on the FTP server. To specify the number indirectly, use three Words from the specified address.
- If you do not specify a string in the [User Specified String] field, the folder is named "NONAME."

9 [Timeout] field, enter how much time is spent trying to connect to the FTP server (for example, 60 seconds).



10 In [Control Word Address], specify a Word address (for example, D100) to control saving.

Click the icon to display an address input keypad.

Select the device "D" and enter "100" in the address, then press the "Ent" key.

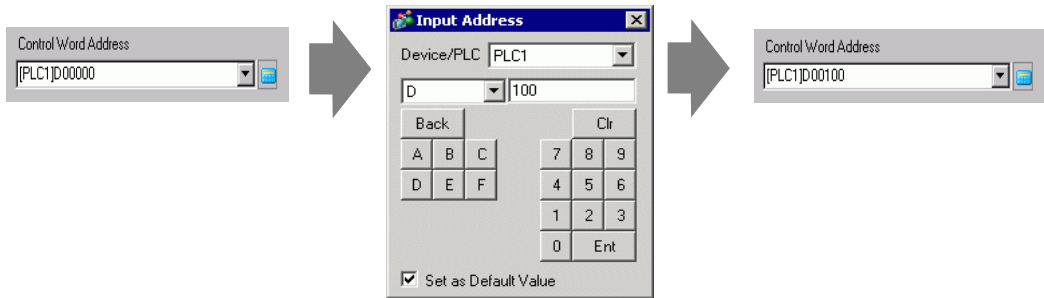

Movie save setting on the FTP server has been successfully completed

NOTE

- The video signal can be displayed while it is being recorded.
- Stored movie files cannot be played while a video signal is being recorded.

◆ Operating Procedure

Use two sequential Words from the specified address to control saving.

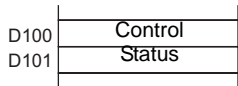

- 1 Turn ON bit 0 of D100 to start recording (saving on the FTP server).
Bit 0 of status address (D101) turns ON while saving.
- 2 Turn OFF bit 0 of D100 to stop recording.

27.4 Recording Video Before and After a Malfunction

27.4.1 Introduction

The AGP-3450T/3550T/3560T/3650T/3750T saves a movie file of the video signal before and after a malfunction has occurred when the defined Trigger Condition is true.

This feature captures the malfunction on the assembly line, which is useful in investigating the cause.

When the trigger bit address is turned ON during monitoring, up to 60 seconds of video before the event and 60 seconds of video after the event is saved as a movie file to a CF Card or FTP server.

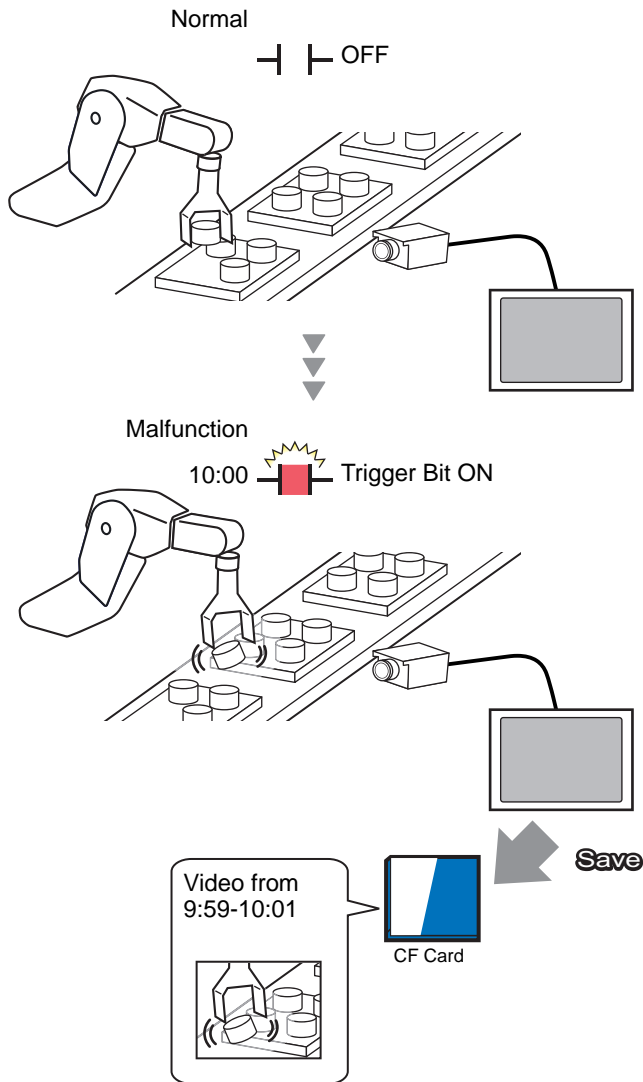

27.4.2 Setup Procedure

NOTE

- Please refer to the Settings Guide for details.
 ☞ "27.9.1 [Video/Movie] Settings Guide" (page 27-75)

Saving video as a movie file before and after an assembly line malfunction or other event. When the trigger bit address is turned ON (and the monitoring bit is also ON) video is saved to a CF Card.

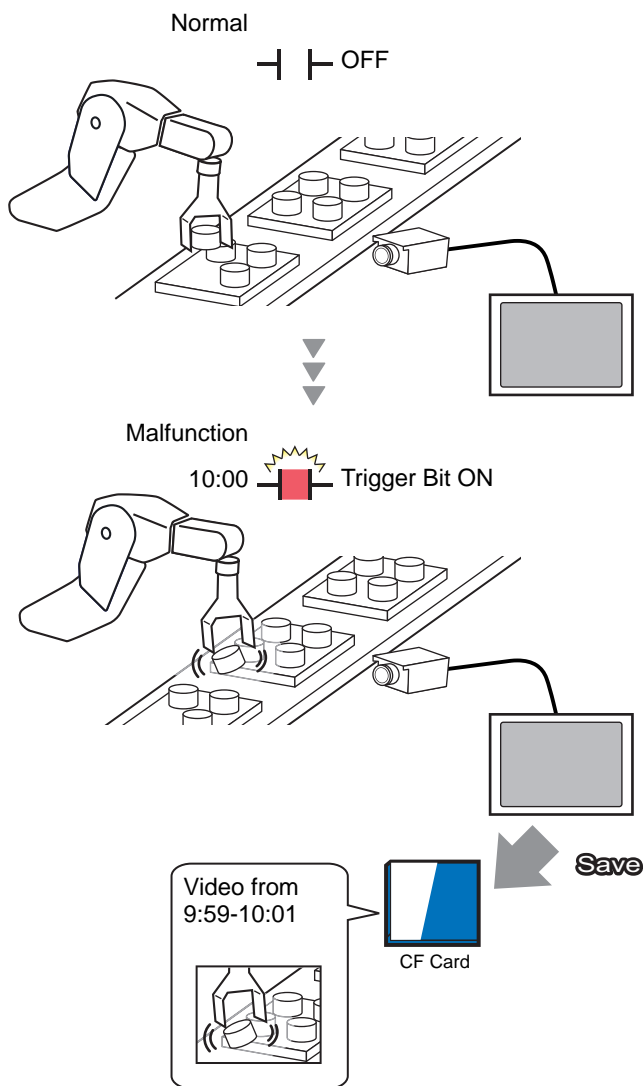

1 In [System Settings], click [Video/Movie].



NOTE

- If the [System Settings] tab is not displayed in the workspace, on the [View (V)] menu, point to [Workspace (W)], and then click [System Settings (S)].

2 Select [Video Input] and [Record Size].

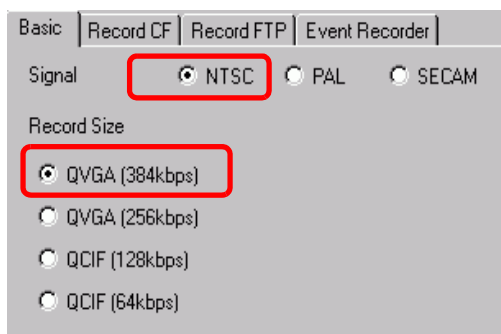

3 [Event Recorder] tab, select the [Record Events] check box.



NOTE

- Movies cannot be played while the [Record Events] function is enabled.

4 Under [Trigger Condition], select [Bit], and under [Condition], select [Bit ON].

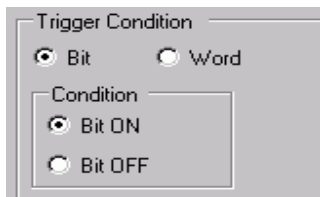

5 In the [Bit Address] box, specify the bit address to start saving. (For example, X100)

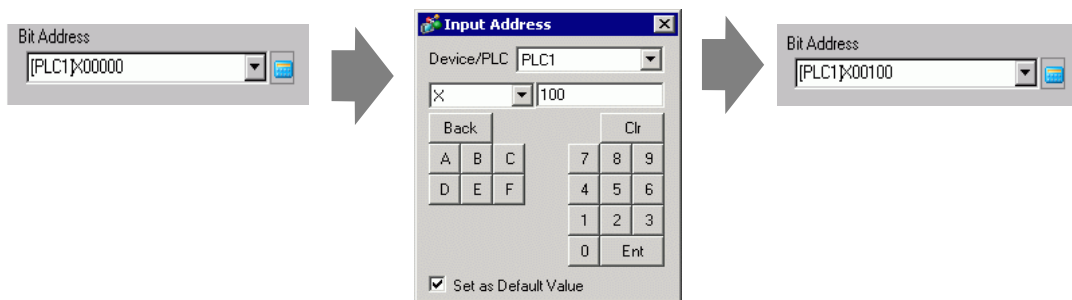

6 Select [Control Address] as a monitoring condition, and set an address to control monitoring. For example, set up D100. Two sequential words from the specified address are used for control.

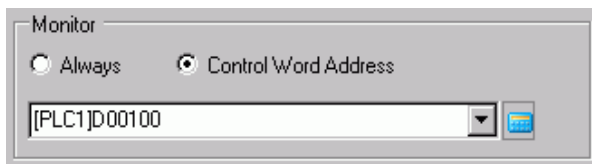

D100	Control
D101	Status

NOTE

- If bit 0 (monitoring bit) of the specified control address is not ON, movie files cannot be saved even with the trigger bit address ON.
- When [Always] is selected for the monitoring conditions, [Event Recorder] monitoring is always ON and movies cannot be played.

7 Under [Record Time], specify the seconds to record (for example, 60) before and after a trigger occurs.

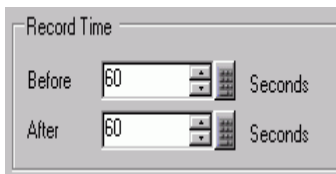

- 8 Under [Record], select [CF Card]. In the [User Set String] area select [Direct] and enter two single-byte characters (for example, MC). This string is the folder name and the first two characters of the file name for the saved movie.

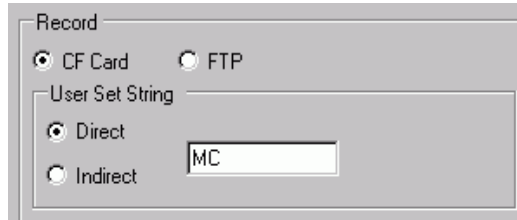

NOTE

- The movie can be saved to either a CF card or an FTP server. You cannot save the movie until the current recording process is completed.
 - The movie is saved under a file name consisting of the user set string (two characters) + time stamp (saves the starting year, month, day, hour, minute, second) and file extension .sdx.
For example, if a folder and file are saved at 15:23'26" on May 27, 2006, the file name will be "MC060527_152346.SDX".
 - If [Indirect] is selected, you must store the user set string with PLC before saving to the CF card. To specify the number indirectly, use three Words from the specified address.
 - If [User Set String] is not set, the folder will be named "NONAME".
-

The settings are complete.

NOTE

- The video signal can be displayed even when Event Recorder is enabled.
-

27.5 Playing Movies

27.5.1 Introduction

On AGP-3450T/3550T/3560T/3650T/3750T models, you can play back the recorded video (*.SDX). Touch the movie player buttons to pause and rewind, to help you find details in the video.

There are two methods for playing movie files saved on a CF Card or FTP server.

■ Using a Playlist

If you know the movie files you want to play, for example, to display a process recorded in movies, first register the movie files you want to play in a playlist. If several movie files are registered in the playlist, the files will be played sequentially in that order.

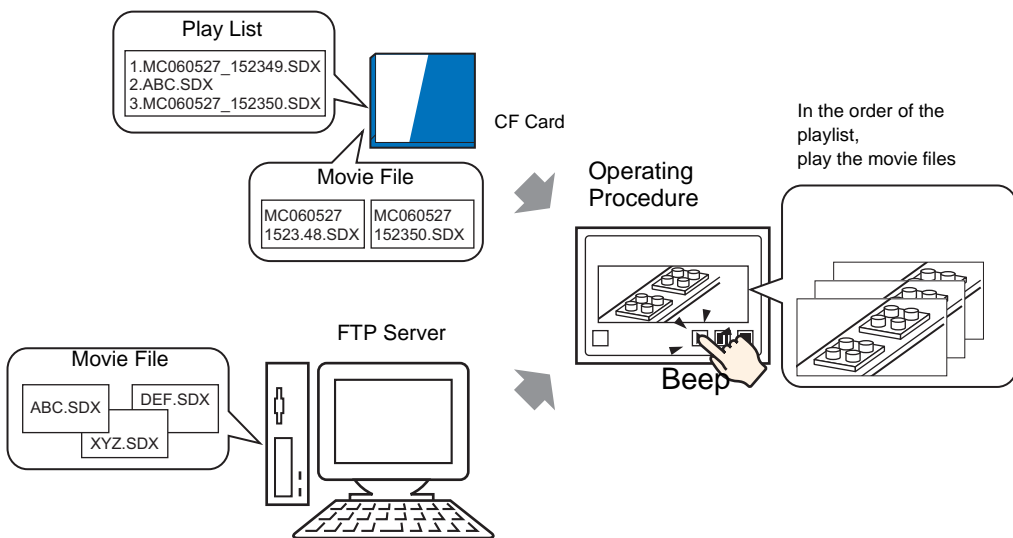

■ Selecting a Movie at Run Time

Using Special Data Display [File Manager], a user can play a particular movie file by touching the desired file.

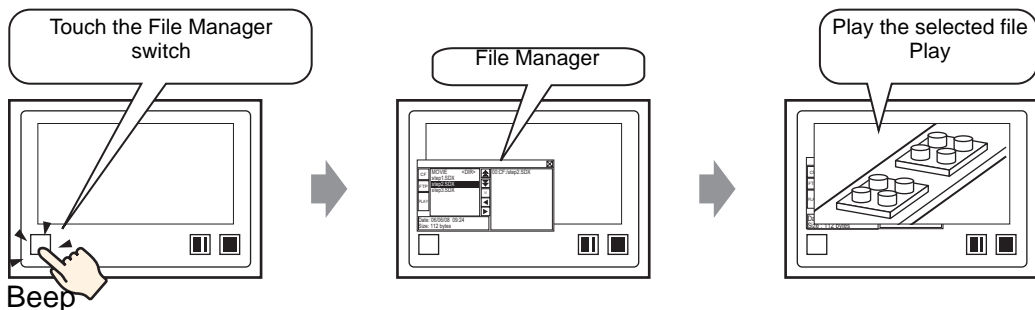

NOTE

- Using [Movie Converter], you can convert PC movie files to a format playable on GP.
 ☞ "27.5.3 Converting Movie Files" (page 27-43)

27.5.2 Setup Procedure

NOTE

- Please refer to the Settings Guide for details.
 - ☞ "27.9.3 Common [Movie] Settings Guide" (page 27-97)
 - ☞ "27.9.4 [Movie Player] Settings Guide" (page 27-99)
 - ☞ "25.10.2 [Special Data Display] Settings Guide ■ File Manager" (page 25-83)
- For details of the part placement method and the address, shape, color, and label setting method, refer to the "Part Editing Procedure".
 - ☞ "8.6.1 Editing Parts" (page 8-44)

■ Using a Playlist

Determine the order of the movie files in the playlist, and play the movies in that order.

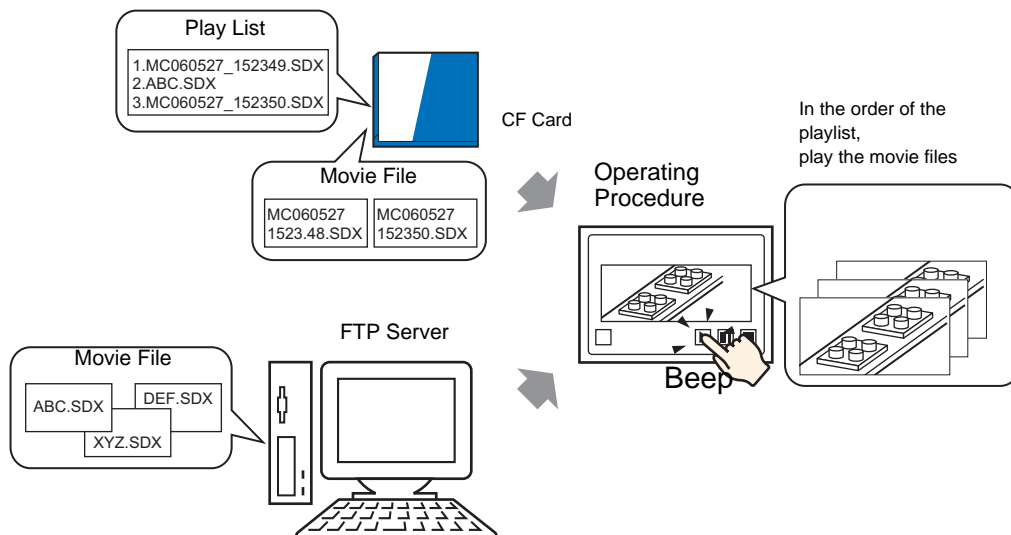

◆ Creating a Playlist File

NOTE

- To create a playlist file and save it on a CF Card, you must specify the CF Card folder.
- If you have specified the [Destination Folder] already, the following message is not displayed. Begin specifying settings from procedure 3.
 - ☞ " ■ Setting the Destination Folder" (page 5-53)

1 On the [Common (R)] menu, click [Movie (O)] or click . The following dialog box appears. [Yes (Y)] displays the [Project Information] dialog box.

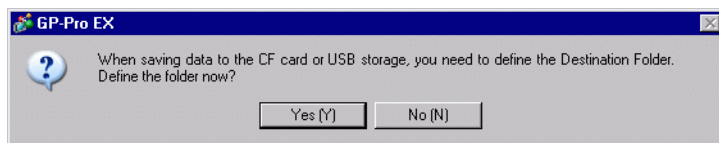

- 2 Select the [Enable CF Card] check box, specify the folder in which the movie files are stored, and click [OK].

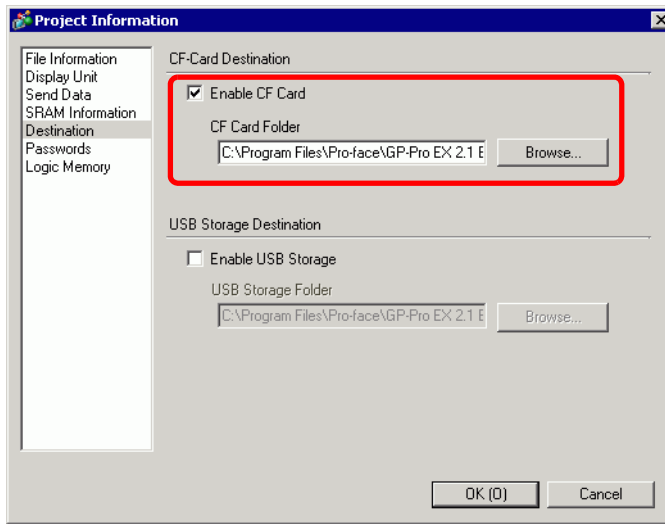

- 3 The [Movie] dialog box appears. [Select [Playlist] and click [New].

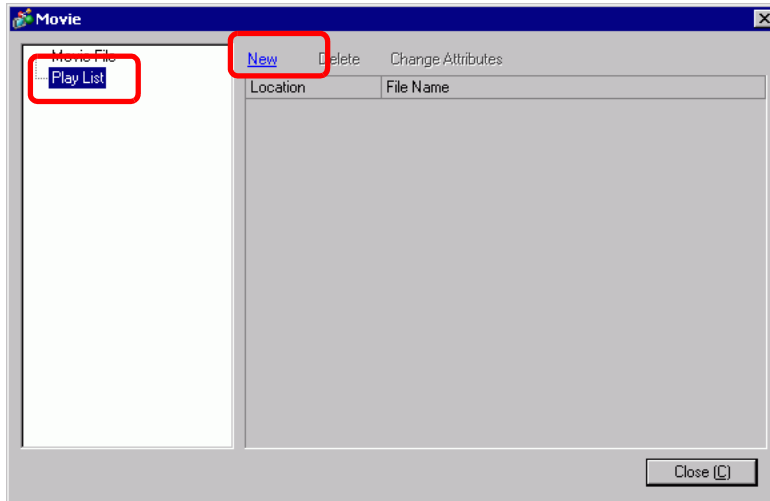

- 4 The [New Play List] dialog box appears. Enter the playlist file name (for example, Line-A) and click [OK].

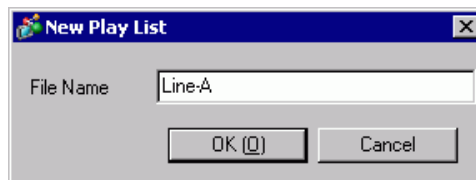

5 Select the created file and click [Add].

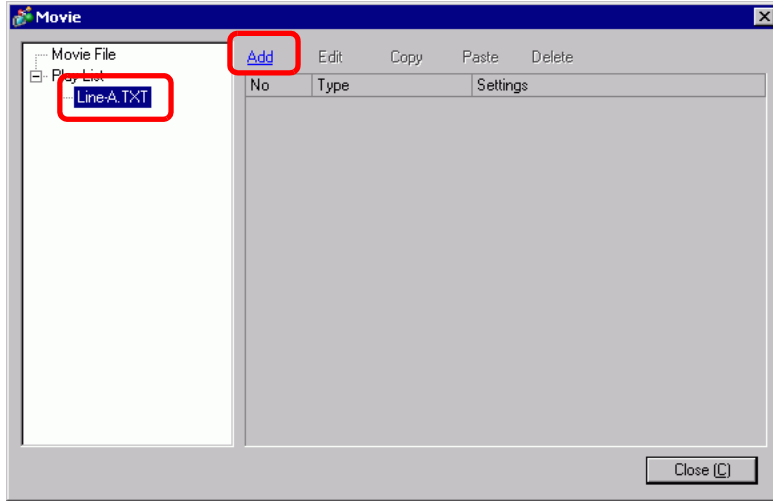

6 In the [Add] dialog box, select the [Play CF File] option. [Select the [Play CF File] option, in the [File Name] field type the file name of the movie (for example, MC060527_152346.SDX) to add to the playlist, and then click [OK]. If the file resides in the "MC" folder, type: MC\MC060527_152346.SDX.

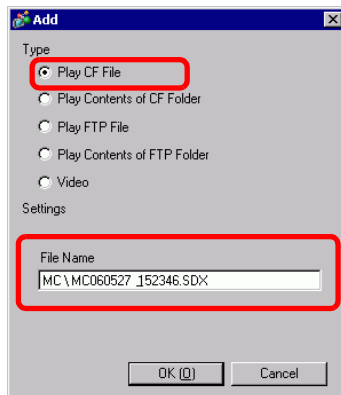

7 You can register movie files in the order you want to play them. After completing the registration, click [Close].

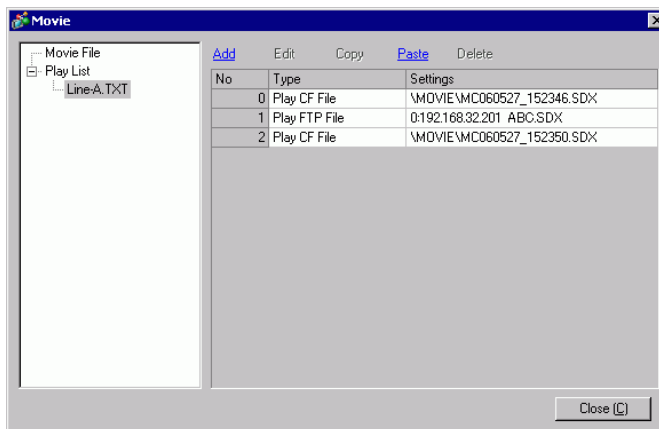

NOTE

- To create a play list on the FTP Server, use a text file (such as Notepad) to create a file in the following format.
You can specify the created file (TXT) by selecting [FTP] in the movie player - [Play List].

Format

- Specify a movie file on the CF Card
(serial Number),CF\MOVIE\(\folder name)\(file name.SDX)
 - Specify a folder on the CF Card.
(serial number),CF,\MOVIE\(\folder_name)\
 - Specify a movie file on the FTP server.
(serial number),FTP,FTP(FTP server registration number),(\folder name) \file_name.SDX
 - Specify a folder on the FTP server
(serial number),FTP,FTP(FTP server registration number),(\folder name)\
 - Display real-time video.
(serial Number),INVM
- The serial number is assigned to the first line starting from 0 and then assigned sequentially to the following lines. Lines can be created from 0 to 99.
 - If you want to add comments, type the pound symbol (#) at the beginning of the line then type the comments. Lines with comments or line breaks do not affect movie play.
 - The FTP server registration number is the number registered in [FTP Server].
 - Separate the folder name and file name using "\".
 - Use single-byte characters for the file name of the playlist file. The playlist file name must use the extension .TXT.
 - The maximum number of movie files that can be played is 100.

For example:

```
#Play list 1  
0,CF,\MOVIE\MC\MC060527_152346.SDX  
1,FTP,FTP0\MC\ABC.SDX  
2,CF,\MOVIE\MC\MC060527_152350.SDX
```

◆ **Creating the Movie Play Screen**

- 8 In the [Screen List] window open the base screen where you want to display the video.
On the [Parts (P)] menu, click [Movie Player (O)], or click  and place a movie player on the screen.

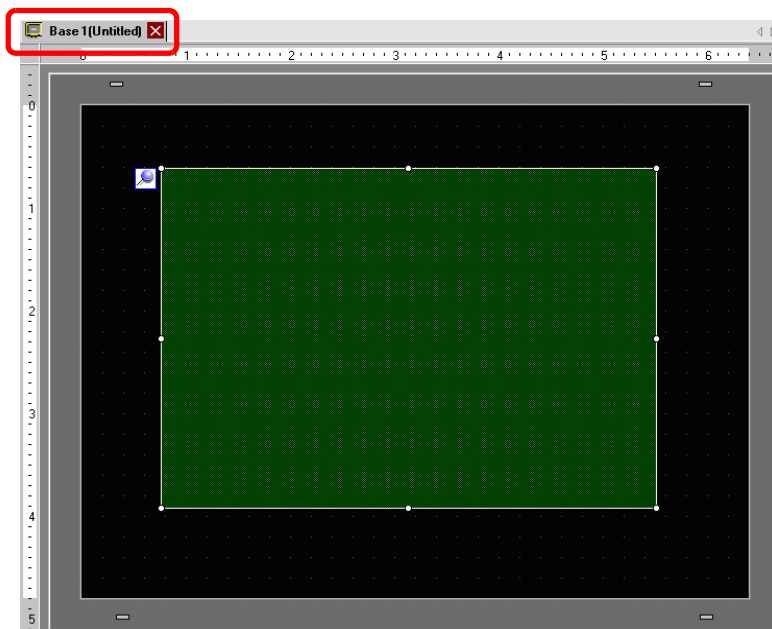

- 9 Double-click the movie player. The following dialog box appears.
 In the [Display Size] area select [1/4].

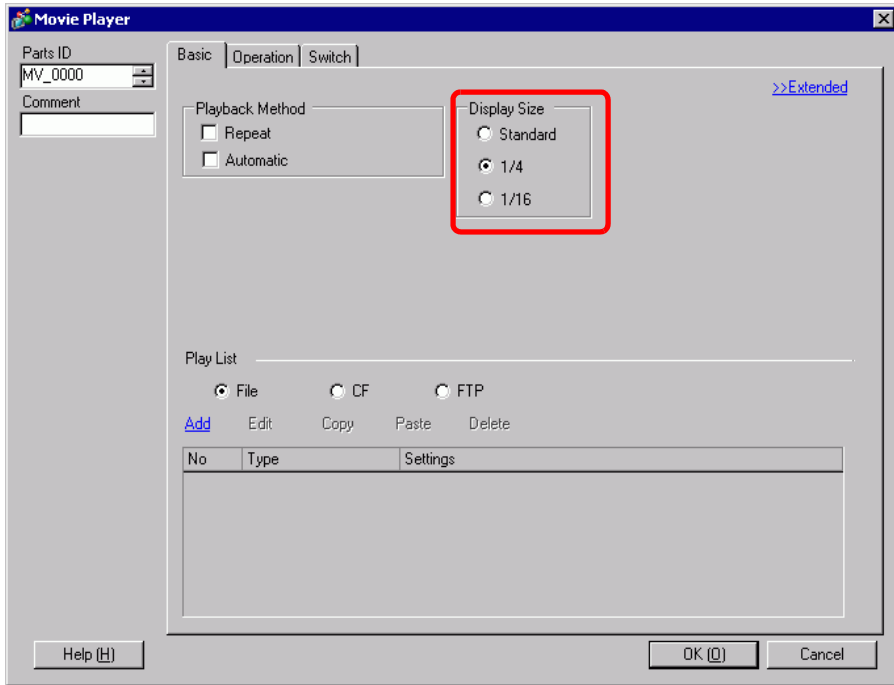

NOTE

- If the selected [Display Size] is larger than the size of the GP screen or the movie player, the entire image is not displayed. If you want to display the entire image, set the [Display Size] smaller than the size of the movie player.

- 10 In [Playlist], select [CF] and select the check box next to the file created in step 7. (For example, Line-A.TXT)

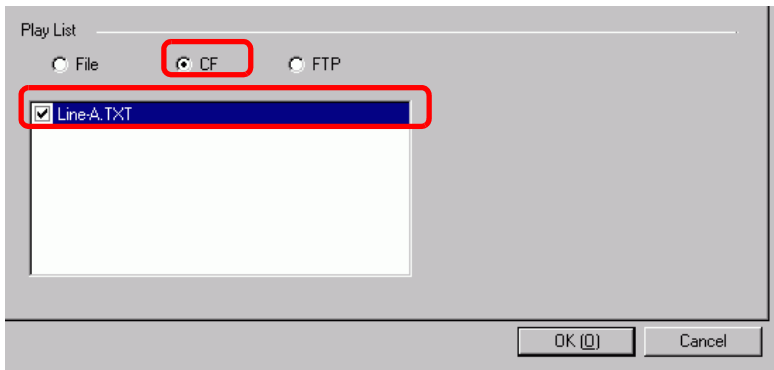

NOTE

- If you select [File], the playlist can be specified in the Movie Player. In this case, the playlist file is not required.

11 Click [Extended] and select the [Play List Order] check box.

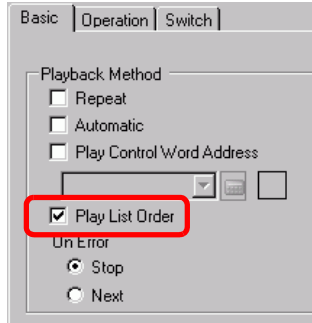

12 Configure a switch for operation. [Click the [Switch] tab, and in the [Switch Layout] area select the [Play], [Pause], and [Stop] check boxes.

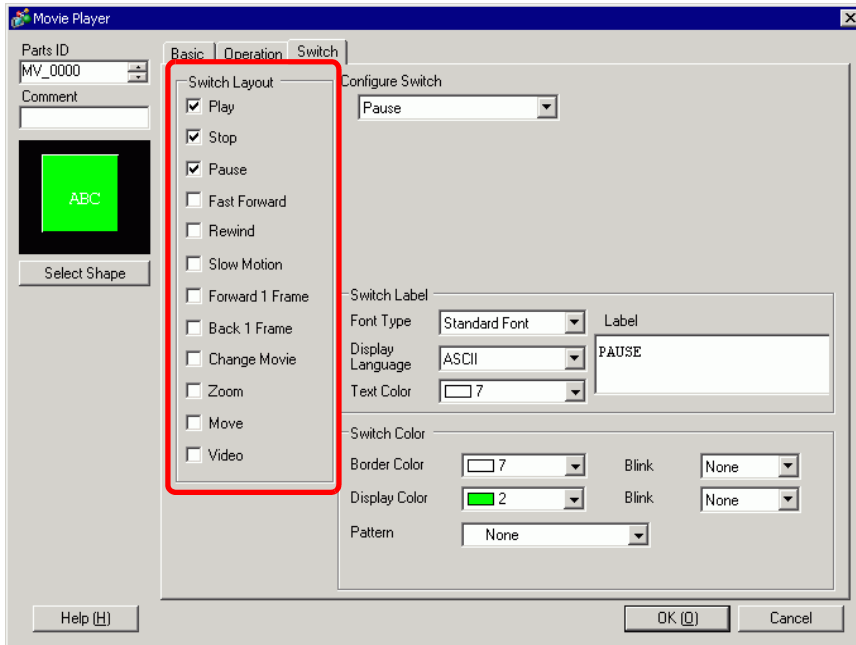

13 In [Select Shape], select the shape of the switch, and specify the label and color as necessary. Click [OK] to complete the settings.

NOTE

- You cannot specify individual shapes and colors for switches drawn using the [Switch] tab on the [Movie Player] part. You can only specify individual labels. If you want to define specific shapes and colors for each switch, do not use the [Switch] tab. Instead, use the Switch/Lamp part to create a [Movie Player Switch] from the [Special Switch] settings.
 ☞ "10.15.4 Special Switch" (page 10-70)
- Depending on the shape of the switch, you may not be able to change the color.
- When you select a switch and press the [F2] key you can directly edit the label text.

The switches can be individually selected and moved to a desired location.

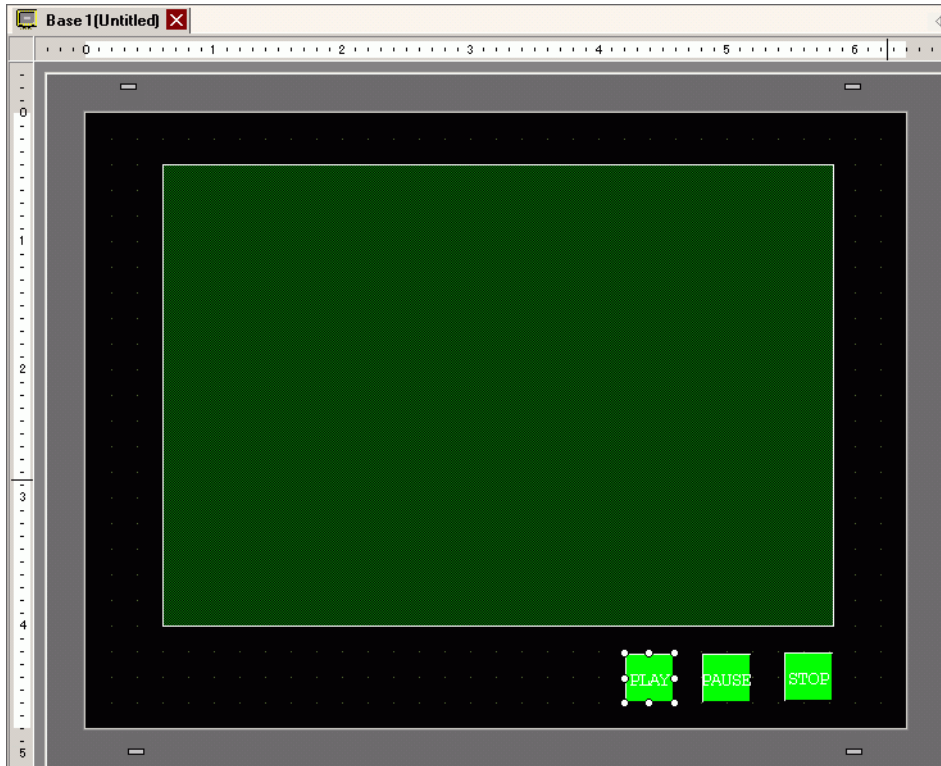

■ Selecting a Movie at Run Time

Selecting the movie file on the GP screen immediately causes the movie to play.

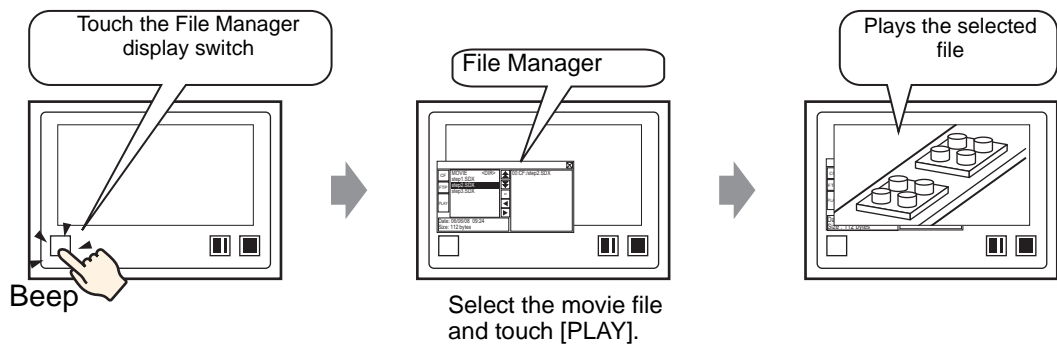

- 1 From the [Parts (P)] menu, point to [Special Data Display (P)] and select [File Manager (M)]. Place the File Manager on the screen.

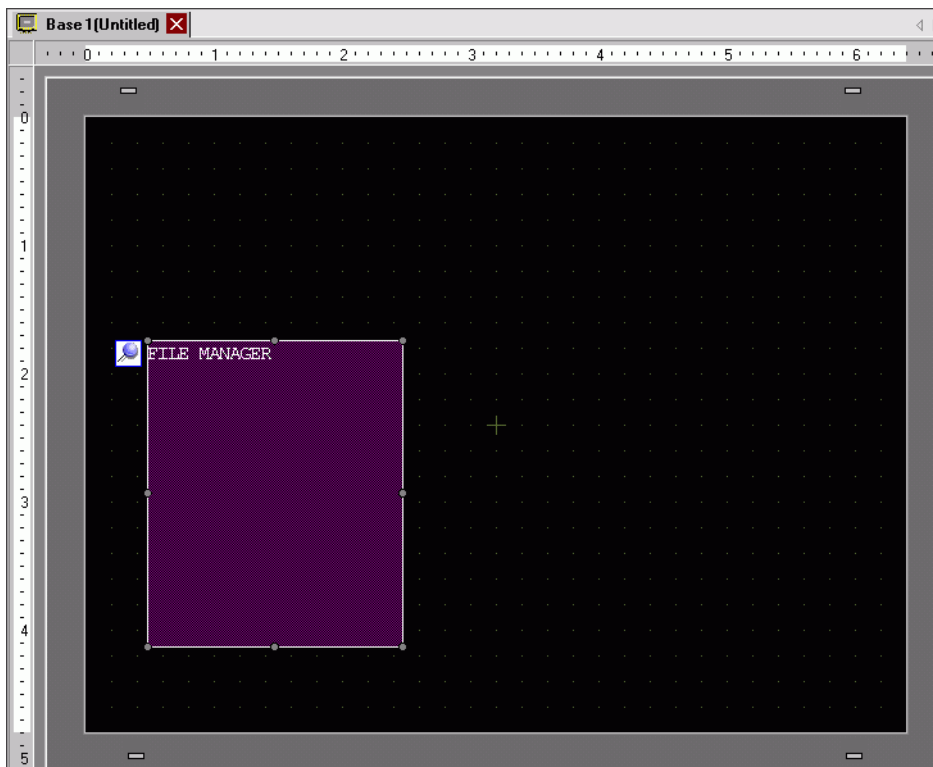

2 Double-click the Special Data Display [File Manager]. The following dialog box appears.

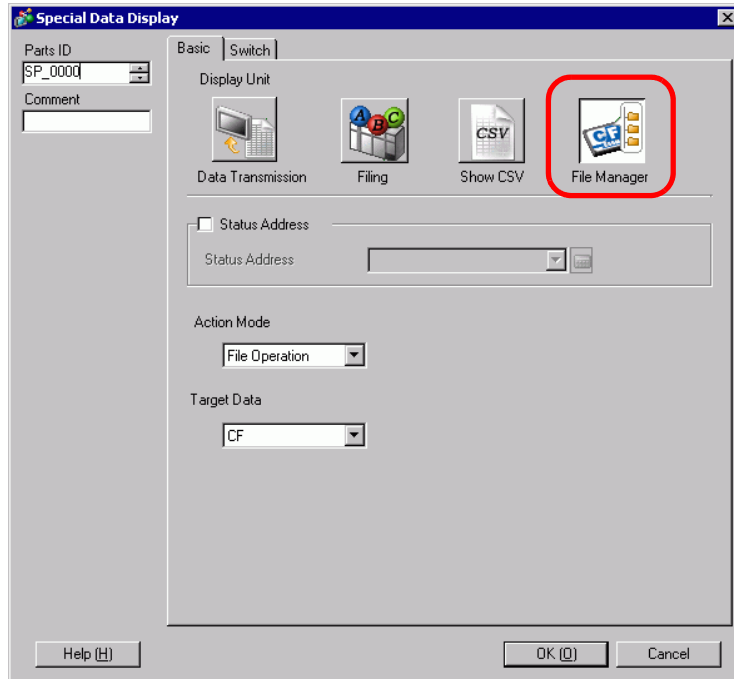

3 [Action Mode], select [Select Movie]. [Selection Mode], select [Multiple]. [Target Data], select [CF/FTP].

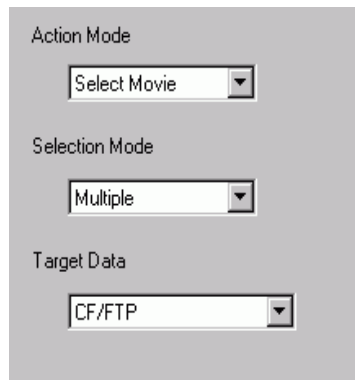

- 4 Click the [Switch] tab and under [Switch Layout] select the [Display] check box. Select the shape of the File Manager switch, specify the label and color, and click [OK].

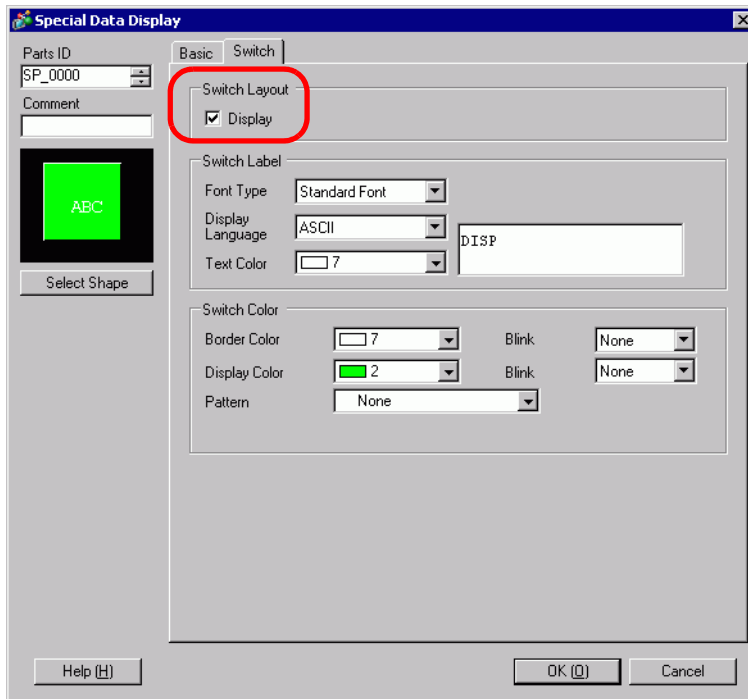

The Special Data Display [File Manager] has been specified. The switches placed with the [Switch] tab under [File Manager] can be individually selected and moved to a desired location.

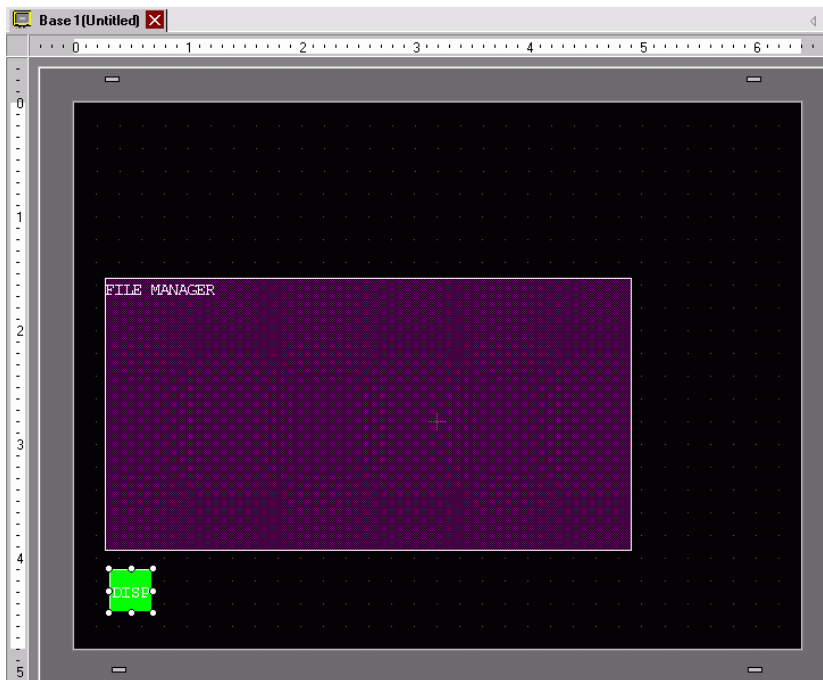

NOTE • Only one Special Data Display [File Manager] can be placed on one screen.

- On the [Parts (P)] menu, click [Movie Display] and place it in the same Base screen as [File Manager].

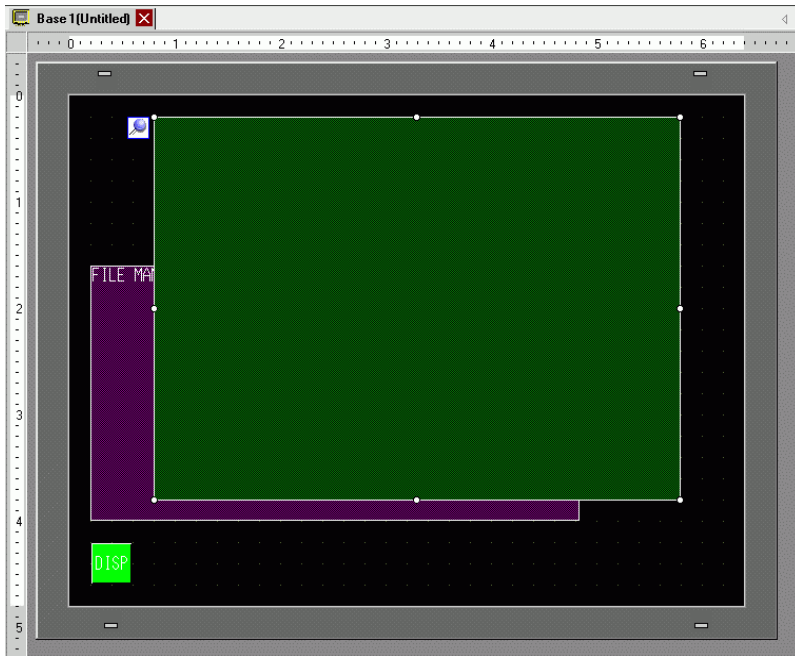

- Double-click the movie player. The following dialog box appears. In the [Display Size] area select [1/4].

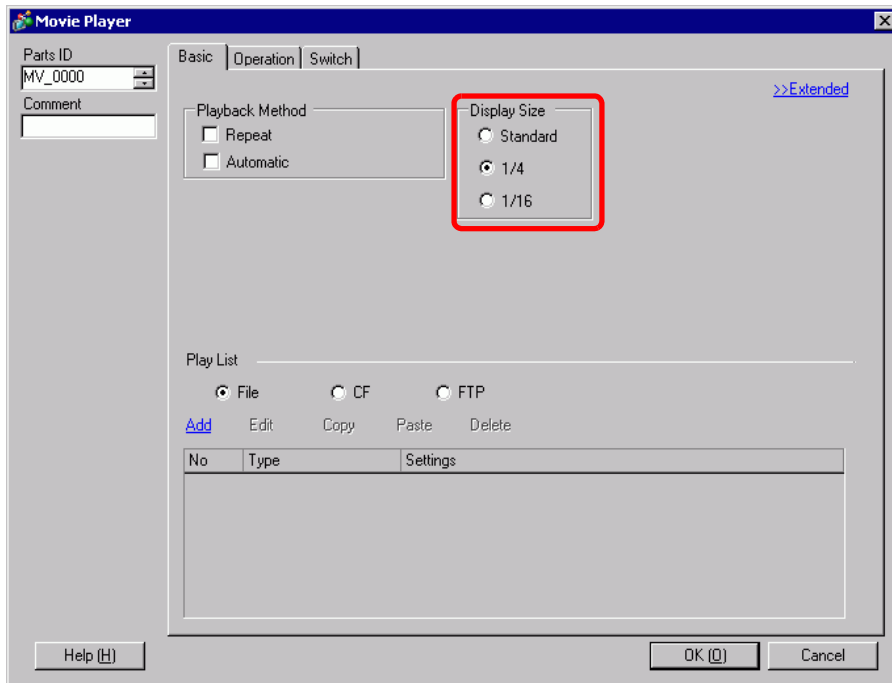

- NOTE**
- If the selected [Display Size] is larger than the size of the GP screen or the movie player, the entire image is not displayed. If you want to display the entire image, set the [Display Size] smaller than the size of the movie player.

7 Place the operation switch. Click the [Switch] tab and, under [Switch Layout], select [Stop] and [Pause].

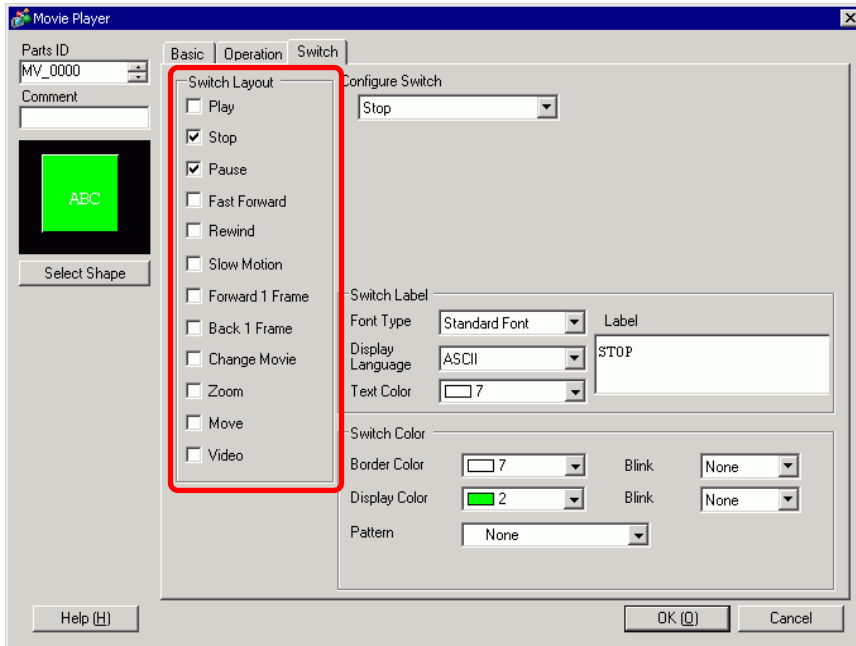

8 In [Select Shape], select the shape of the switch, specify the label and color, and click [OK].

NOTE

- You cannot specify individual shapes and colors for switches drawn using the [Switch] tab on the [Movie Player] part. You can only specify individual labels. If you want to define specific shapes and colors for each switch, do not use the [Switch] tab. Instead, use the Switch/Lamp part to create a [Movie Player Switch] from the [Special Switch] settings.
 ↳ "10.15.4 Special Switch" (page 10-70)
- Depending on the shape of the switch, you may not be able to change the color.
- When you select a switch and press the [F2] key you can directly edit the label text.

The switches placed with the [Switch] tab in [Movie Player] can be individually selected and moved to a desired location.

◆ **Using File Manager to Play Movies**

1 Touch the File Manager Display Switch to call up [File Manager] on the GP screen.

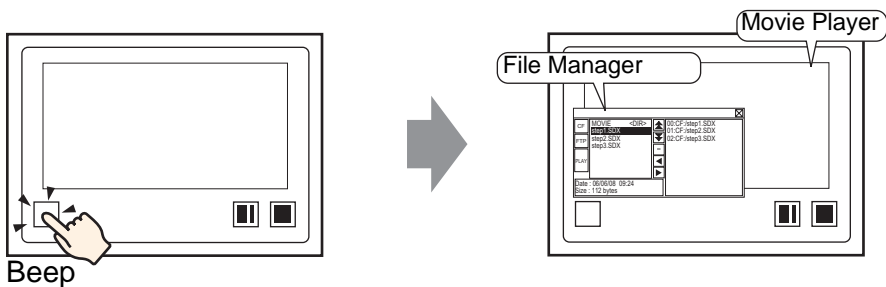

If you touch the display switch again, [File Manager] will close.

2 Setting [Selection Mode] on the Special Data Display [File Manager] to [Plural] and setting [Target Data] to [CF/FTP] displays the following contents.

<DIR> displays to the right of the folder name.

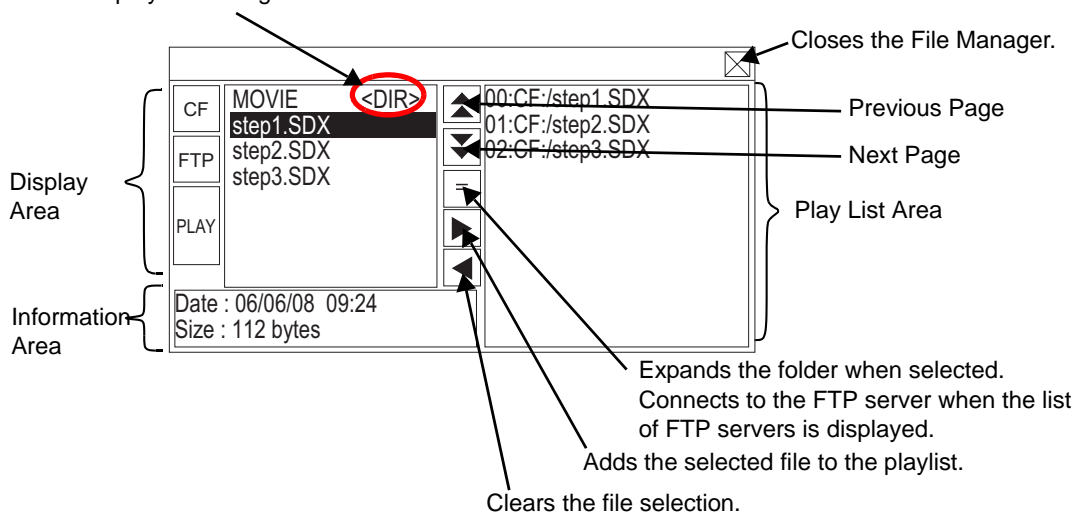

- **Display Area**
 Touch [CF] or [FTP] to select the file location.
 Selecting [CF] displays a list of the folder names or file names on the CF Card.
 Selecting [FTP] displays a list of host settings names on the FTP server list when not connected to the FTP server.
 The files display in the order in which they were created. It is not possible to sort the files by file numbers or time stamps.
 Touching [PLAY] starts playing the files with GP-Pro Ex.
- **Information Area**
 When you select a folder, the folder creation date displays. Selecting a file displays the creation date and size of the file.
 The FTP server list displays the IP addresses and user names of the selected hosts.
- **Play List Area**
 The names of the files to be played are displayed in the list. The files are played in the order of this list.

3 Selecting the folder and touching the [=] key displays a list of all the files in the folder.

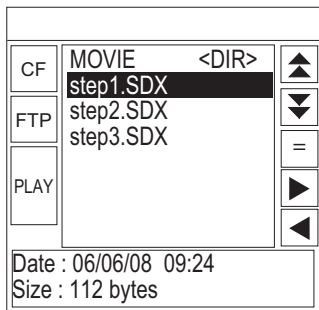

CF Card

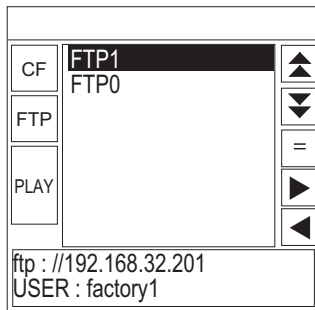

FTP Server

NOTE

- To return to the above tree (the list of folders) from the file list page, select ".. <DIR> " in the first line and touch the [=] key.
- After connecting to the FTP server selected with [=] key, selecting [FTP] displays the file list.

4 On the GP, select the movie file you want to play and touch the [▶] key to add the file to the playlist.

Touching [PLAY] starts playing the files in the order registered in the playlist.

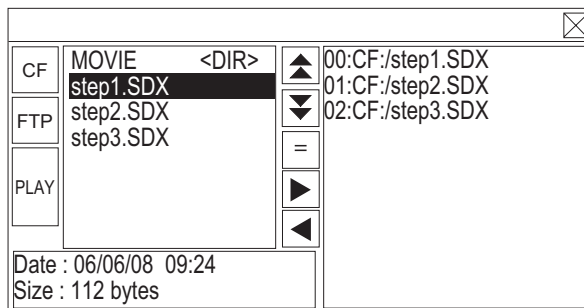

How to Move File Manager

The screen position of Special Data Display [File Manager] can be changed.

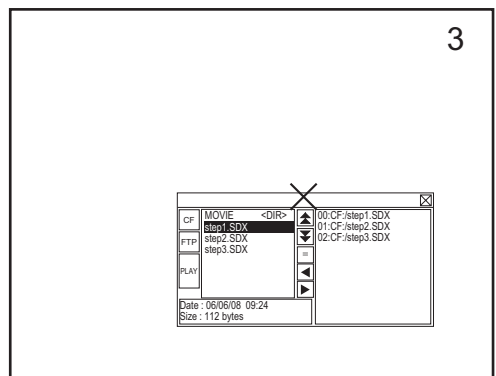
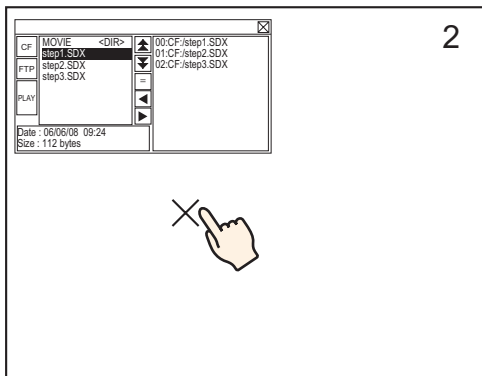
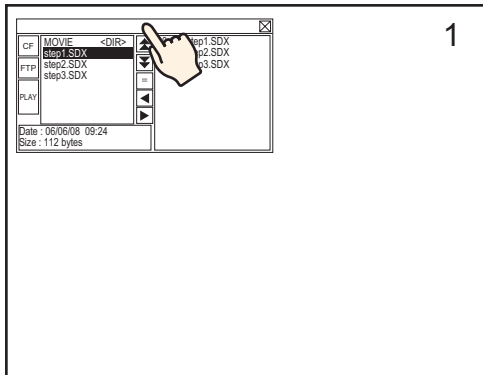

- 1 Touch the top of the [File Manager] Display.
- 2 Touch the desired position on the screen where you want the display to move.
- 3 The [File Manager] moves to the specified location.

NOTE

- If the [File Manager] Display runs off the screen at a specified position, the coordinates adjust so that the entire window displays.

27.5.3 Converting Movie Files

To display movie files from a PC on the GP, you need to convert the file into a GP proprietary file format (*.SDX). Convert movie files into SDX format using the [Movie Converter] software. This movie converter can also convert movie files in SDX format into other formats playable on PC.

IMPORTANT

- To install the movie converter, a license is required. Purchase the license separately.
- When using the Movie Converter on the PC, a codec that supports movie file compression needs to be installed. (A codec may be installed in video/audio players such as Windows Media Player[®] as a standard feature.)

Movie Converter Operating Environment

	Specifications	Remarks
PC	Windows [®] compatible machine	Pentium [®] III 1GHz or faster is recommended
Hard Disk Space	60 MB or more	This capacity is required to install Movie Converter.
Memory	256 MB or more	512 MB or more recommended
Operating System	Windows [®] 2000 Service Pack 4 Windows [®] XP Home Edition/ Professional Edition) Service Pack 2 or later	
Others	Windows Media [®] Player 9.0	For details on Windows Media [®] Player, see the Microsoft web site.
	Mouse	Make sure the mouse is compatible with the operating system above.
	CD-ROM drive	This is required only for installation. Make sure to use a drive that accepts the OS above.

■ Installation of the Movie Converter

- 1 Place the GP-Pro EX installation CD-ROM (Disk2) in the computer's CD drive. The SET UP MENU screen will appear.
- 2 [Movie Converter] should be clicked.
- 3 The install screen appears. Install according to the procedure. The keycode is included in the license.

■ Starting Movie Converter and Converting Movies

- 1 On the task bar, click [Start], point to [Programs (P)], [Pro-face], and then click [Movie Converter].

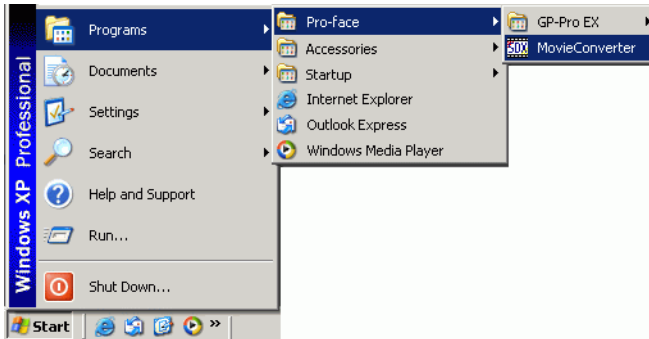

- 2 [Movie Converter] will start. [Add] button displays the [File Settings] dialog box.

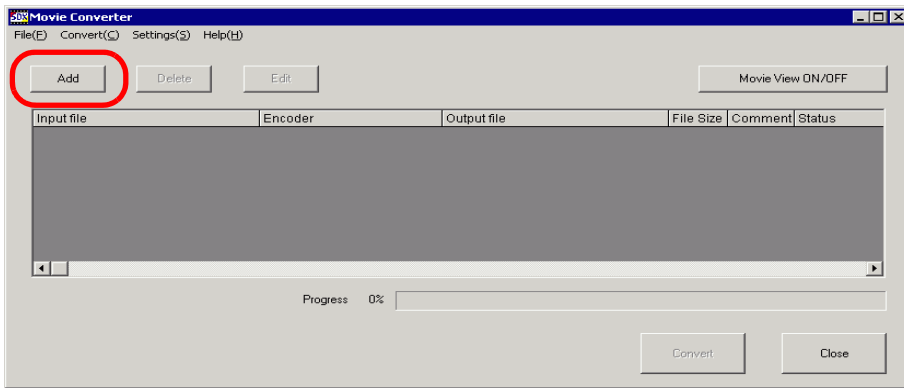

NOTE

- When the [Image Conversion In Progress] window is displayed, the name of the movie being converted is displayed in the window. [Image Conversion in Progress] window remains open until you click [Movie View ON/OFF].

- 3 Select [Other Format->SDX Format]. [Input File]'s ellipsis [...] displays the [Open File] dialog box.

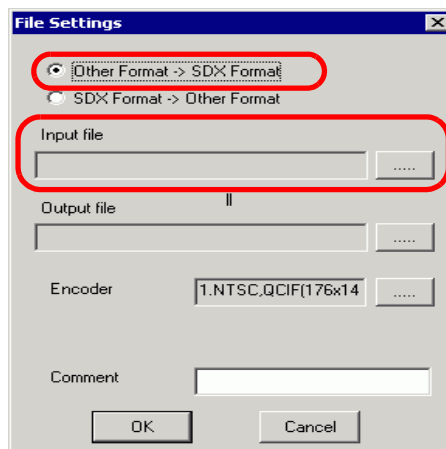

4 Select [Look in] and [File Name (N)] for the file to convert, and then click [Open].

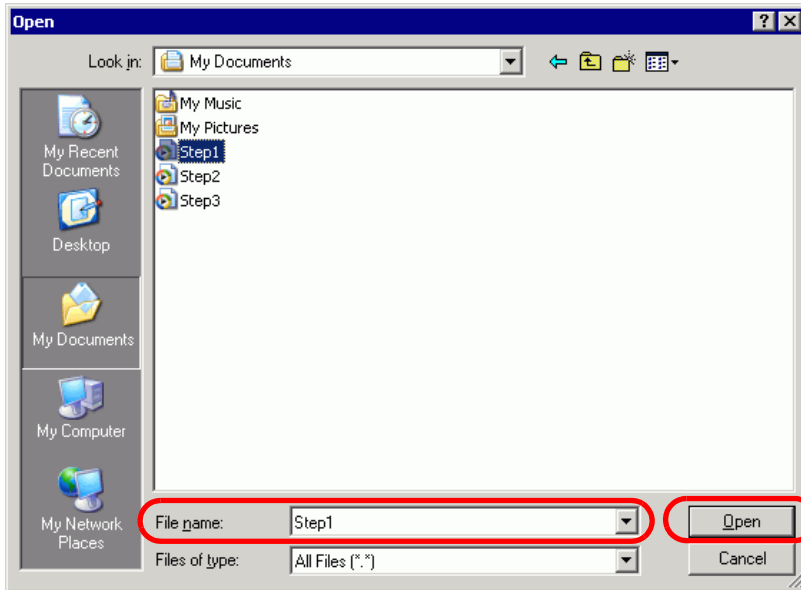

5 Return to the [File Settings] dialog box. [Output File]'s ellipsis [...] displays the [Save As] dialog box.

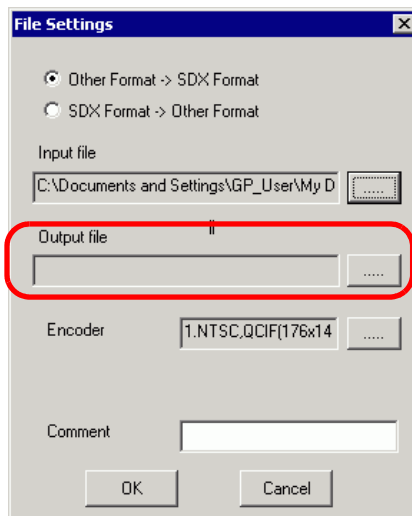

6 Specify [Save in] and [File Name (N)] for the file to be converted, and click [Save].

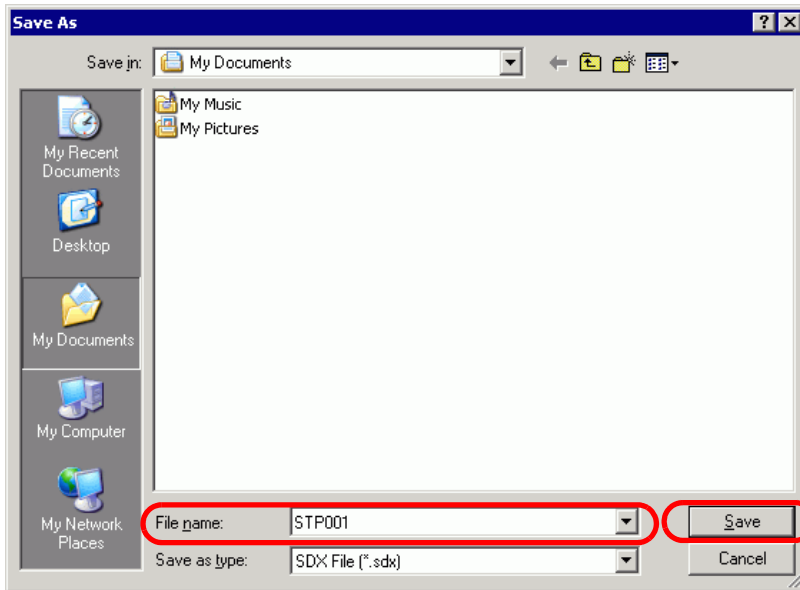

7 Select the conversion encoding in [...] in [Encoder], and click [OK].

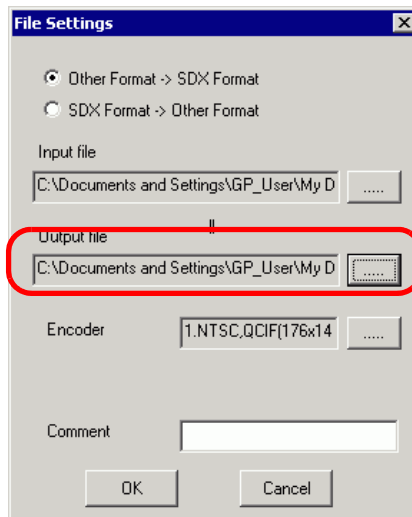

NOTE

- In the Movie Converter, using the [Settings (S)] menu's [Default Settings (S)] command, you can initialize the Encoder, Video, and Audio settings.

8 A list containing the specified files is displayed. The state of the current file can be checked in [Status]. Clicking [Convert] starts the conversion.

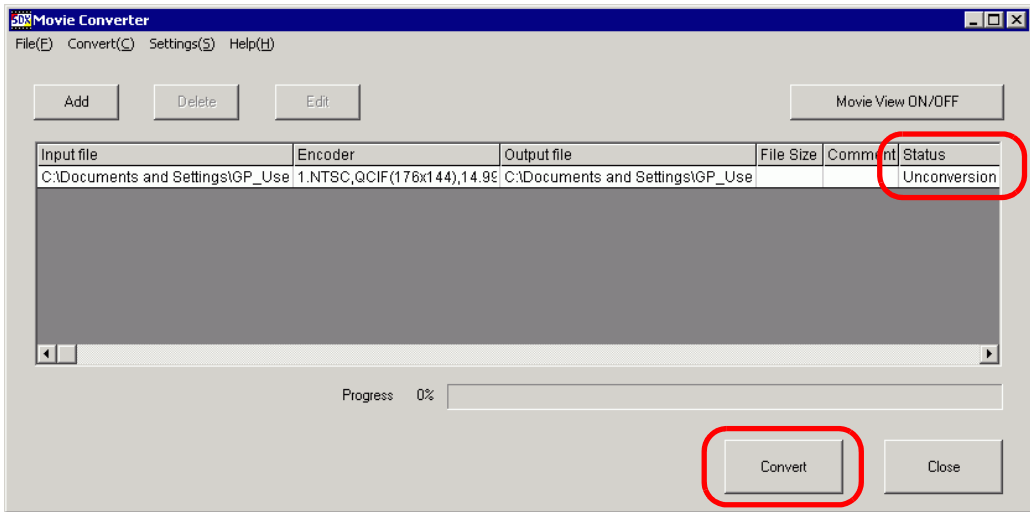

NOTE • If multiple conversion settings are specified, all the conversions displayed in the list are performed in sequential order.

9 During conversion, [Status] for the file list is displayed as [Conversion In Progress] and the state of the conversion is displayed in [Progress].

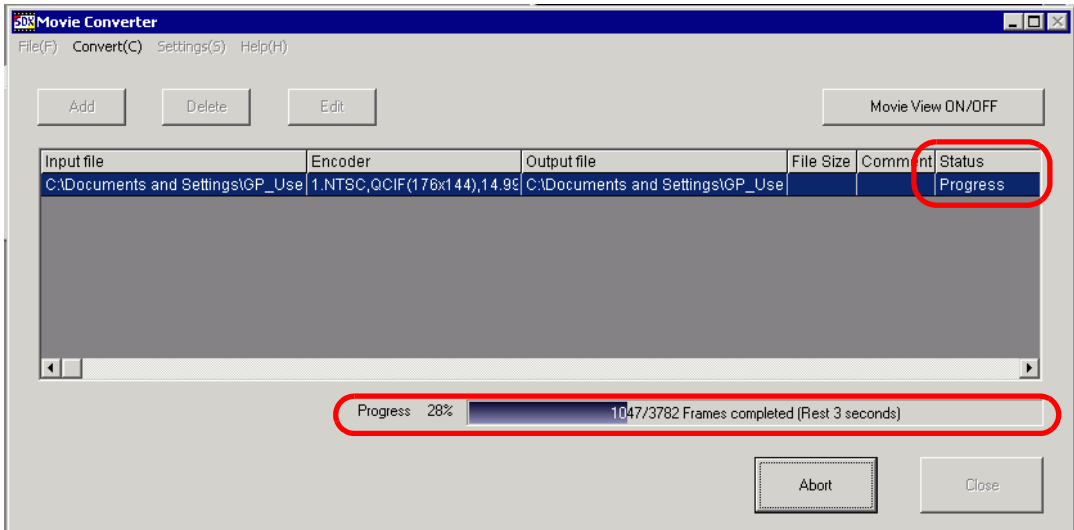

NOTE • Clicking [Stop] will stop the conversion.

10 After conversion is successful, the following message appears. Click [OK].

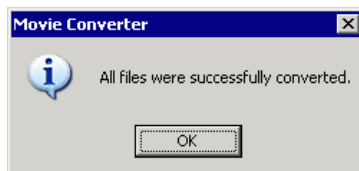

■ Movie Converter Setting Guide

"Movie Converter" is a tool for converting movie files on a PC to a GP-specific movie file format (*.SDX) and for converting a GP-specific movie file to a format playable on a PC. On the [Start] menu, select [Movie Converter] from [Pro-face] in [Program (P)] to start up the converter.

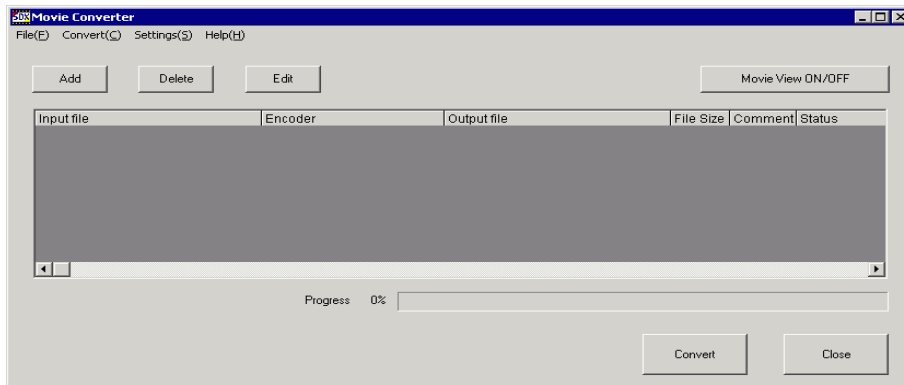

Setting	Description
Add	In the opened [File Settings] dialog box, you can register a list of movie files for conversion.
Delete	Deletes the selected file from the file conversion list.
Edit	Changes the settings for the file selected from the file conversion list.
Movie View ON/OFF	Shows/hides the Image Conversion In Progress window.

NOTE

- From the [Settings (S)] menu, select [View Log (V)] to check the movie converter operation log.

File Settings

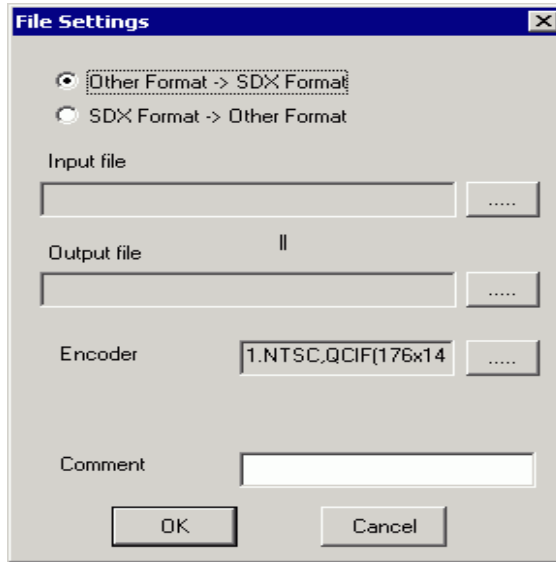

Setting	Description																																				
Other Format -> SDX Format Conversion	Converts other formats to SDX format. NOTE <ul style="list-style-type: none"> Any movie can be selected for conversion regardless of the movie format. After conversion, the original file extension will be changed to SDX as the default. 																																				
	Input File	Click [...] to select a movie file for conversion.																																			
	Output File	Click [...] to specify the location for saving the converted file and to specify the file name.																																			
Encoder	The following settings can be selected.																																				
	<table border="1"> <thead> <tr> <th>Input Image Signal</th> <th>Record Size</th> <th>Number of Frames</th> <th>Bit Rate</th> </tr> </thead> <tbody> <tr> <td>NTSC</td> <td>QCIF (176 x 144)</td> <td>14.99 fps</td> <td>64 kbps</td> </tr> <tr> <td>NTSC</td> <td>QCIF (176 x 144)</td> <td>14.99 fps</td> <td>128 kbps</td> </tr> <tr> <td>NTSC</td> <td>QVGA (320 x 240)</td> <td>14.99 fps</td> <td>256 kbps</td> </tr> <tr> <td>NTSC</td> <td>QVGA (320 x 240)</td> <td>14.99 fps</td> <td>384 kbps</td> </tr> <tr> <td>PAL</td> <td>QCIF (176 x 144)</td> <td>12.50 fps</td> <td>64 kbps</td> </tr> <tr> <td>PAL</td> <td>QCIF (176 x 144)</td> <td>12.50 fps</td> <td>128 kbps</td> </tr> <tr> <td>PAL</td> <td>QVGA (320 x 240)</td> <td>12.50 fps</td> <td>256 kbps</td> </tr> <tr> <td>PAL</td> <td>QVGA (320 x 240)</td> <td>12.50 fps</td> <td>384 kbps</td> </tr> </tbody> </table>	Input Image Signal	Record Size	Number of Frames	Bit Rate	NTSC	QCIF (176 x 144)	14.99 fps	64 kbps	NTSC	QCIF (176 x 144)	14.99 fps	128 kbps	NTSC	QVGA (320 x 240)	14.99 fps	256 kbps	NTSC	QVGA (320 x 240)	14.99 fps	384 kbps	PAL	QCIF (176 x 144)	12.50 fps	64 kbps	PAL	QCIF (176 x 144)	12.50 fps	128 kbps	PAL	QVGA (320 x 240)	12.50 fps	256 kbps	PAL	QVGA (320 x 240)	12.50 fps	384 kbps
	Input Image Signal	Record Size	Number of Frames	Bit Rate																																	
	NTSC	QCIF (176 x 144)	14.99 fps	64 kbps																																	
	NTSC	QCIF (176 x 144)	14.99 fps	128 kbps																																	
	NTSC	QVGA (320 x 240)	14.99 fps	256 kbps																																	
	NTSC	QVGA (320 x 240)	14.99 fps	384 kbps																																	
	PAL	QCIF (176 x 144)	12.50 fps	64 kbps																																	
	PAL	QCIF (176 x 144)	12.50 fps	128 kbps																																	
PAL	QVGA (320 x 240)	12.50 fps	256 kbps																																		
PAL	QVGA (320 x 240)	12.50 fps	384 kbps																																		

Continued

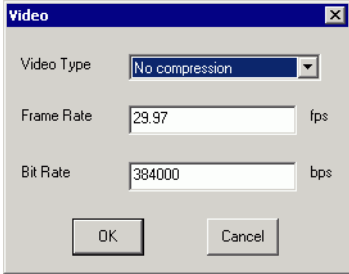
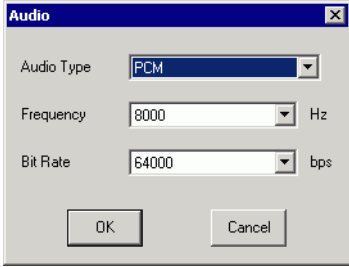
Setting	Description
SDX Format -> Other Format	Converts the SDX format to a format other than SDX.
Input File	Click [...] to select a movie file for conversion.
Output File	Click [...] to specify the location for saving the converted file and to specify the file name.
Video	<p>Click to display the [Video] dialog box.</p>  <ul style="list-style-type: none"> • Video Type The selections vary depending on the codec installed on the PC running Movie Converter. • Frame Rate, Bit Rate The settings will vary depending on the codec installed on the PC running Movie Converter.
Audio	<p>Click to display the [Audio] dialog box.</p>  <ul style="list-style-type: none"> • Audio Type The selections vary depending on the codec installed on the PC running Movie Converter. • Frequency, Bit Rate The settings will vary depending on the codec installed on the PC running Movie Converter.
Comment	Input arbitrary comments. The comments are used to distinguish between movie files on GP-Pro EX

■ **Error Messages**

◆ **List of errors that might occur after conversion (Other Formats -> SDX Format)**

Error	Actions to Take
Memory acquisition failed.	Secure free memory.
DirectX initialization failed.	Confirm that the input file is correct. Confirm that the requirements for the operating environment are satisfied.
Resize initialization failed.	An error occurred in the codec. Check whether the codec is installed. Or, use a different codec.
MPEG4 encoder initialization failed.	
SDX file initialization failed.	
DirectX data acquisition failed.	
Resize failed.	
MPEG4 encoding failed.	
MPEG4 encoder deletion failed.	
SDX file frame data writing failed.	
SDX file close processing (writing) failed.	
Downsampling failed.	

◆ **List of errors that might occur after conversion (SDX Format ->Other Format)**

Error	Actions to Take
Memory acquisition failed.	Secure free memory.
SDX file initialization failed.	Confirm that the input file is correct. Confirm that the requirements for the operating environment are satisfied.
MPEG4 decoder initialization failed.	An error occurred in the codec. Check whether the codec parameters have been specified correctly. Or, use a different codec.
DirectX initialization failed.	
MPEG4 decoding failed.	
DirectX image data writing failed.	
DirectX audio data writing failed.	
DirectX close processing failed.	
Downsampling failed.	

27.6 Displaying Multiple Video Camera Outputs Simultaneously

27.6.1 Introduction

If you install the Video Module Unit on AGP-3500T/3510T/3550T/3560T/3600T/3650T/3750T models, you can display images from up to four video cameras on one screen. It is useful for viewing images from various angles.

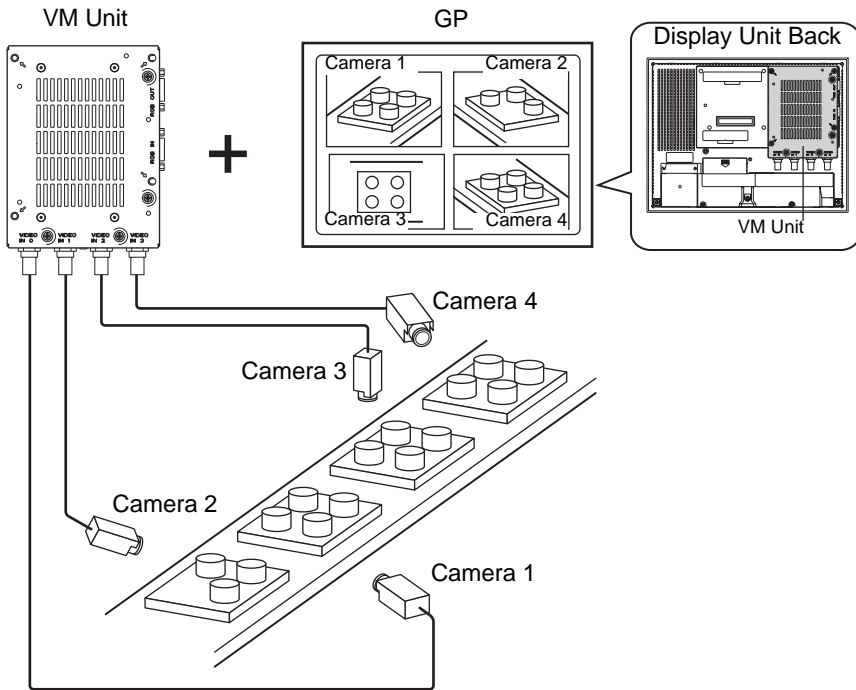

NOTE

- You can install the video module for GP3000 series on the AGP-3750T. For other models, you can install video modules for GP2000 or GP3000 series.
- For information about video module specifications and installation, please see "GP2000 Series VM Unit Users Manual" or "GP3000 Series VM Unit Users Manual".
- You can display the PC screen on one of the four split screens.
 ☞ "27.7 Displaying PC Screen" (page 27-61)
- You can capture video as still images and save the images in JPEG format.
 ☞ "27.8 Saving Video Output as Still Images" (page 27-67)

27.6.2 Setup Procedure

NOTE

- Please refer to the Settings Guide for details.
 - ☞ "27.9.5 Common [Image Input Module Window Settings] Settings Guide" (page 27-119)
 - ☞ "27.9.6 [Image Input Module] Settings Guide" (page 27-129)
 - ☞ "27.9.7 Image Input Module Display Settings Guide" (page 27-143)
- For details of the part placement method and the address, shape, color, and label setting method, refer to the "Part Editing Procedure".
 - ☞ "8.6.1 Editing Parts" (page 8-44)

With the Video Module installed, pictures taken from four angles are displayed on the GP screen in real time.

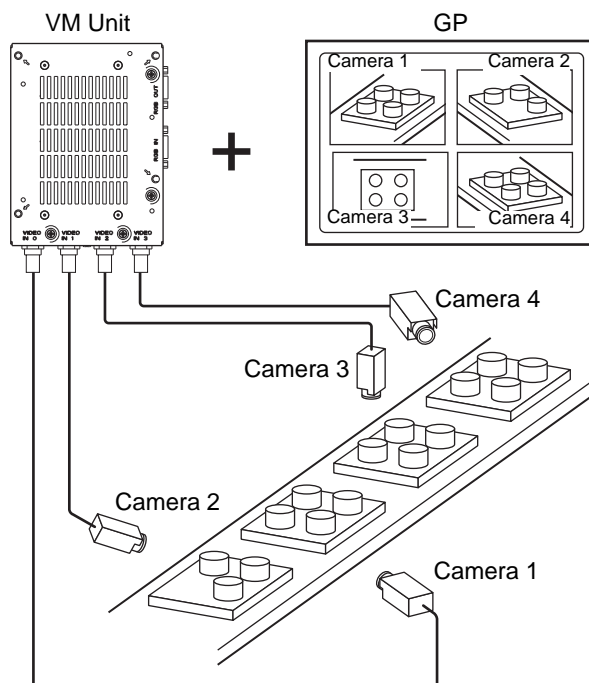

1 In [System Settings], select [Image Input Module].

NOTE

- If the [System Settings] tab is not displayed in the workspace, on the [View (V)] menu, point to [Workspace (W)], and then click [System Settings (S)].

2 Confirm whether [VM Unit (2000)] or [VM Unit (3000)] is selected in [Image Input Module Settings].

For [Video Control Start Address] select [Disable]. In [Signal] select the video signal supported in your region: [NTSC] or [PAL].

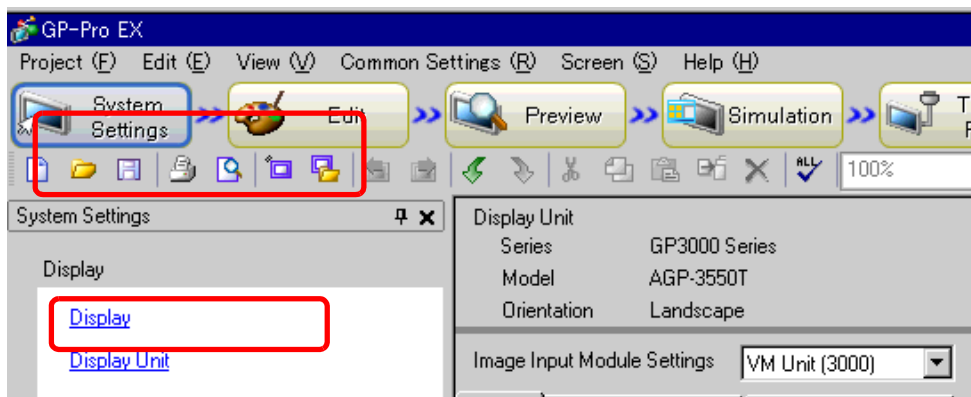

NOTE

- If the [Video Control Start Address] is set to [Enable], 42 Words from the setup control address are automatically used to control the video display. For the items in the video control, see the following.
☞ " ◆ Video Control Area" (page 27-130)

3 On the [Common Settings (R)] menu, select [Image Input Module Window Settings (U)] or click  to open the following dialog box. Select [New] and then specify [Number] and [Comment]. (For example, Number "1", Comment "Video")

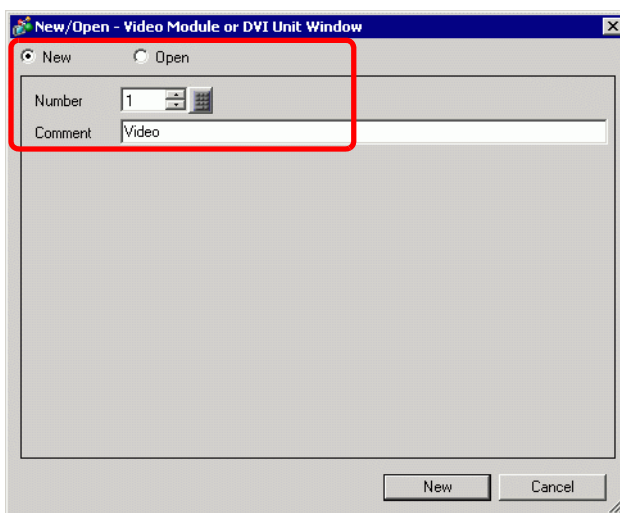

4 The video window [VM1] appears.

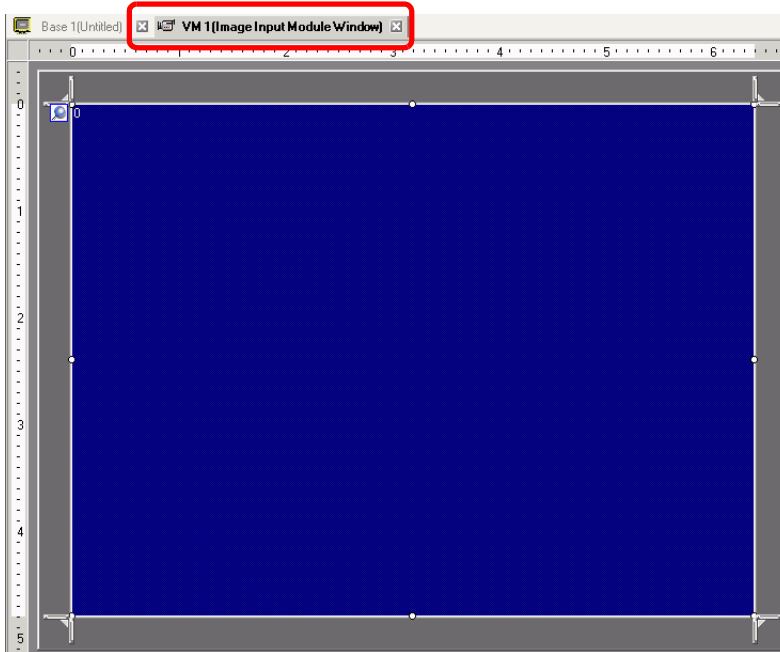

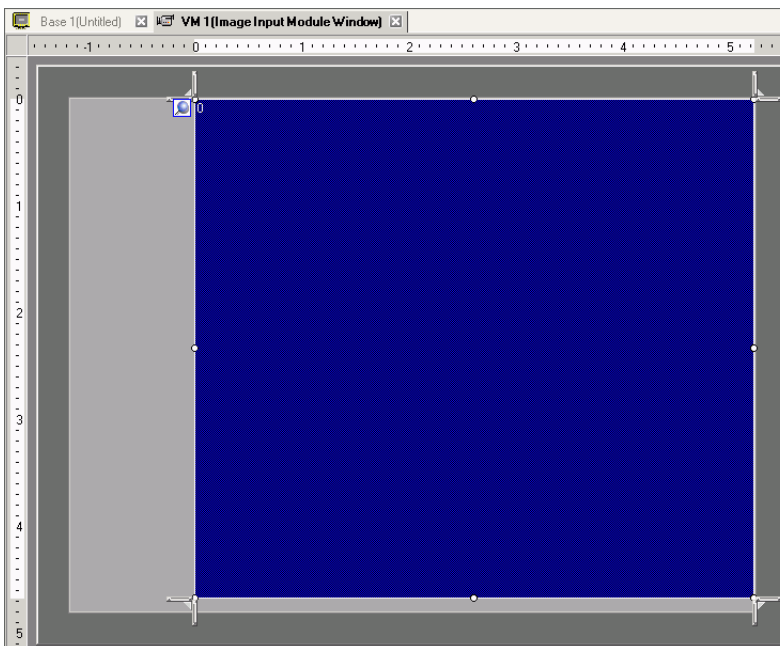

5 Adjust the [Image Input Module Window] size.

To reduce the Window Screens, first reduce the display area (blue parts), then drag the  mark on the four corners to adjust the size. To enlarge, expand the window size and adjust the display area to fit the window size.

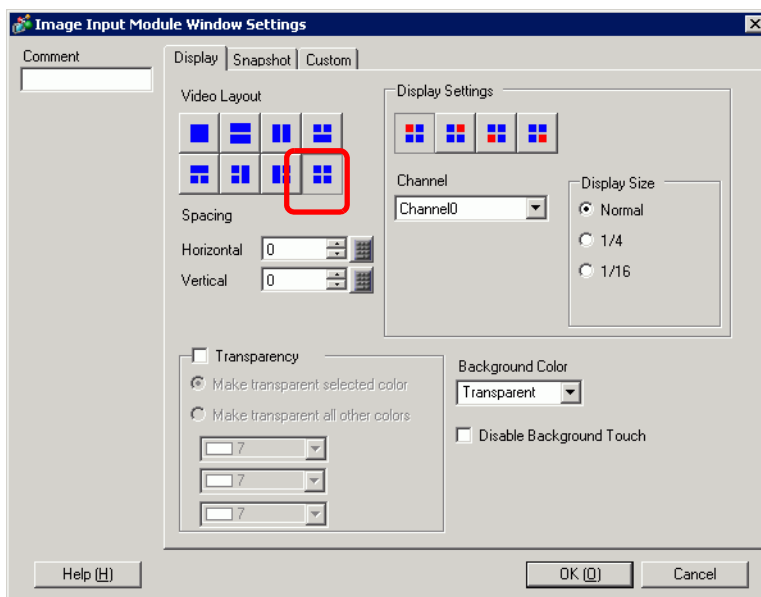

6 Double-click the blue display area. The following dialog box appears. [Video Layout], click the following icon .



7 In the [Display] area, click , and under the [Channel], select the camera image to be displayed in this upper left area (for example, Channel 0). Also select the size of the image (for example, 1/4).

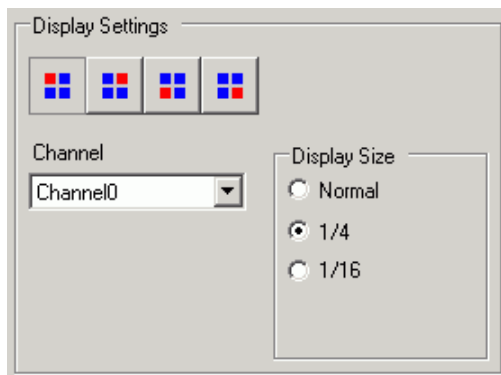

Similarly, select the channels and display sizes for the images displayed in the upper right, lower left, and lower right areas.

NOTE

- If the selected [Display Size] is larger than the display unit or the blue display area, the entire image will not display. You can use [Video Display position] on the [Custom Settings] tab to specify which part of the input image to be displayed. If you want to display the entire image, set the [Display Size] smaller than the size of the blue display area.

- 8 Specify the values for the space between the screens. (For example, horizontal 10, vertical 10) Click [OK] to finish and exit the [Image Input Module Window] settings.

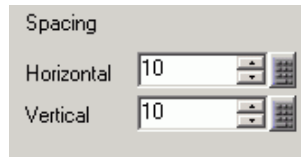

NOTE

- You can drag the dots between each screen to adjust the space between screens.

- 9 Click the [Base 1] tab to display the base screen.

On the [Parts (P)] menu, select [Image Input Module Display (V)] or click  to place an Image Input Module Display on the screen.

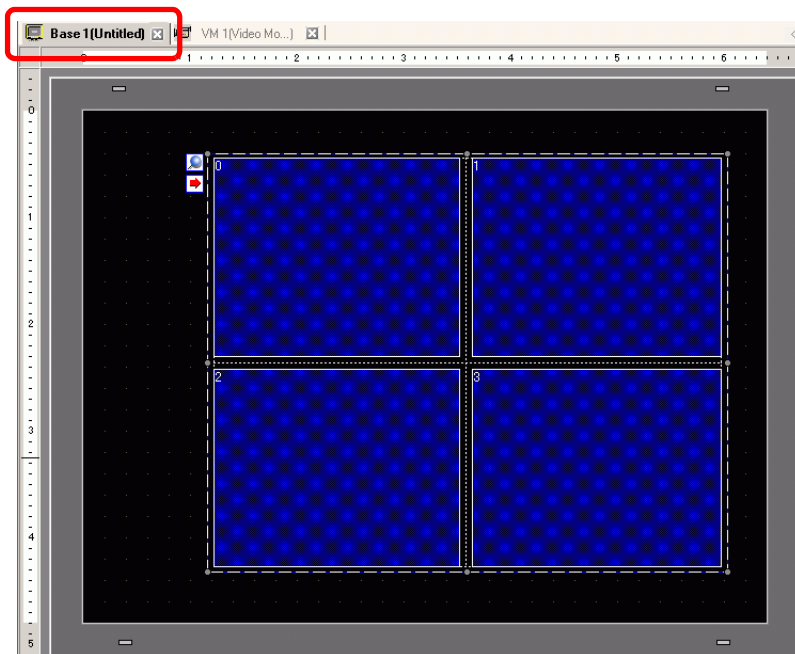

10 Double-click the [Image Input Module Display]. The following dialog box appears.

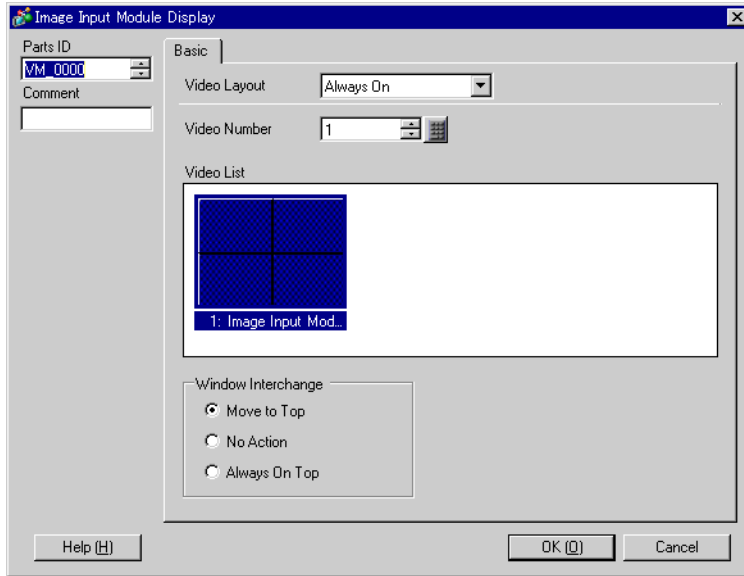

11 In the [Video Layout] list, click [ON/OFF Display] and select the video screen number (for example, 1) in the [Video Number] box.

NOTE

- After you set up the Video Screen, the  icon appears on the [Image Input Module Display]. Click the icon to display the corresponding video screen. This feature is useful for checking or changing the video settings.

12 Under [Window Interchange], select [Move to Top].

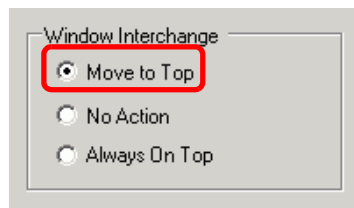

13 In the [Window Display Bit Address] list, select the bit address (for example, M100) for controlling the window display and click [OK].

Click the icon to display an address input keypad.

Select device "M", input "100" as the address, and press the "Ent" key.

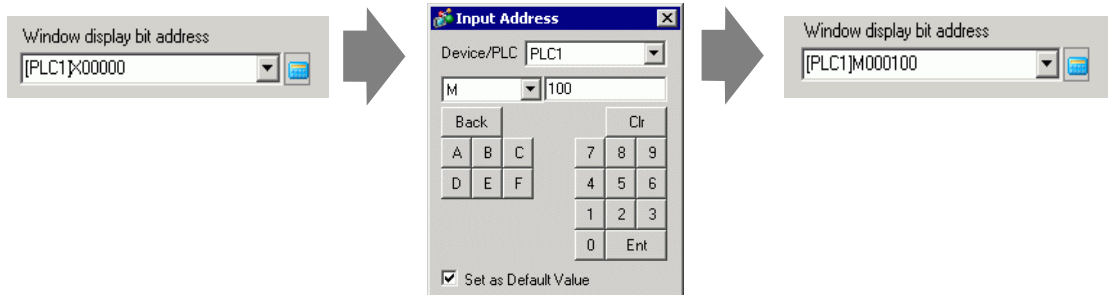

14 Place a switch on the screen to show or hide the [Image Input Module Window].

On the [Parts (P)] menu, point to [Switch/Lamp (C)] and click [Bit Switch (B)], or click  to place the switch on the screen.

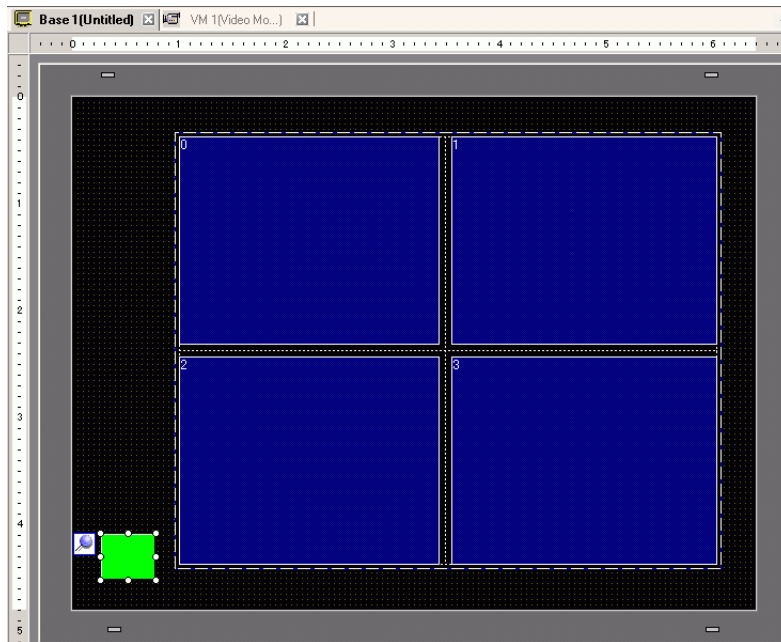

15 Double-click the switch. The following dialog box appears.

In the [Bit Address] list, select the (M100) address for controlling the screen and select [Bit Invert] in the [Bit Action] list.

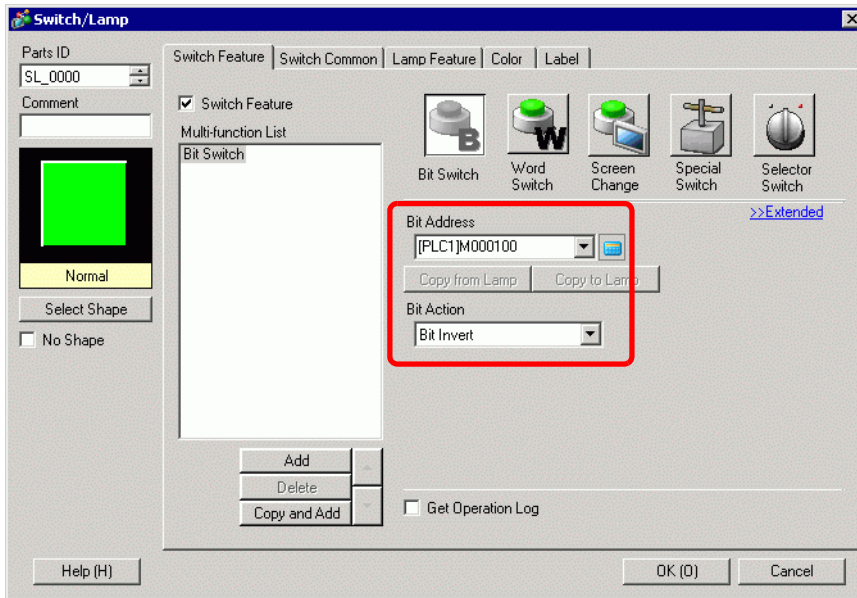

27.7 Displaying PC Screen

27.7.1 Introduction

When an optional "Video Module Unit" or "DVI Unit" is inserted to AGP-3500T/3510T/3550T/3560T/3600T/3650T/3750T, the computer screen can be displayed on GP through an RGB connection to the computer. Using this feature, you can use the GP as a PC monitor.

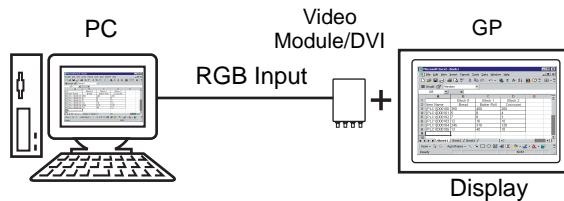

NOTE

- You can install the video module for GP3000 series on the AGP-3750T. For other models, you can install video modules for GP2000 or GP3000 series.
- For information about video module specifications and installation, please see "GP2000 Series VM Unit Users Manual" or "GP3000 Series VM Unit Users Manual".
- Install a touch-panel driver on your PC to output GP touch coordinates through serial communication. You can control the PC's pointer on the GP.

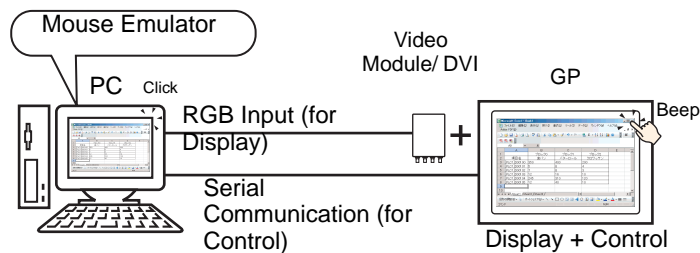

- Please refer to the following for details on restrictions for when the DVI unit is in use.
 ☞ "27.10.3 Restrictions on DVI Unit Features" (page 27-150)

27.7.2 Setup Procedure

NOTE

- Please refer to the Settings Guide for details.
 - ☞ "27.9.5 Common [Image Input Module Window Settings] Settings Guide" (page 27-119)
 - ☞ "27.9.6 [Image Input Module] Settings Guide" (page 27-129)
 - ☞ "27.9.7 Image Input Module Display Settings Guide" (page 27-143)
- Refer to Editing Parts for details about placing parts or setting addresses, shapes, colors, and labels.
 - ☞ "8.6.1 Editing Parts" (page 8-44)

The PC screen is displayed on the screen of the GP with the installed image input module.

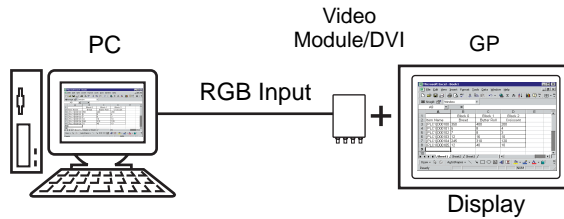

1 In [System Settings], select [Image Input Module].

NOTE

- If the [System Settings] tab is not displayed in the workspace, on the [View (V)] menu, point to [Workspace (W)], and then click [System Settings (S)].

2 Select the unit installed in [Image Input Module Setting] and select [Disable] in the [Video Control Start Address].

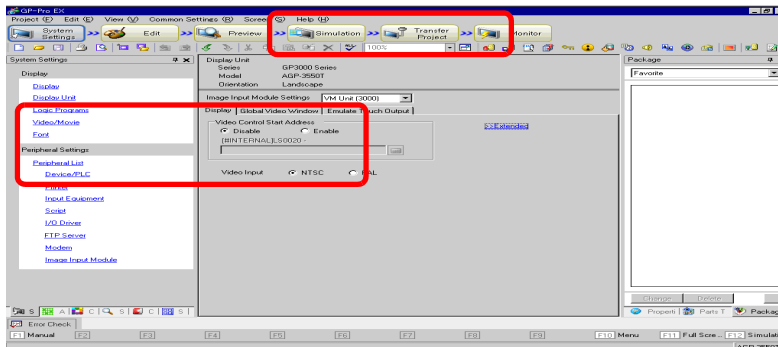

NOTE

- If the [Video Control Start Address] is set to [Enable], 42 Words from the setup control address are automatically used to control the video display. For the items in the video control, see the following.
 - ☞ "◆ Video Control Area" (page 27-130)
- When displaying only the PC screen on the GP using RGB input, you can select either [NTSC] or [PAL] as the video [Signal] without affecting the display. When selecting [DVI Unit], the [Video Input] item will not be displayed.

- 3 On the [Common Settings (R)] menu, select [Image Input Module Window (V)] or click  to open the following dialog box. Select [New], and then specify [Number] and [Comment]. (For example, Number "1", Comment "Video")

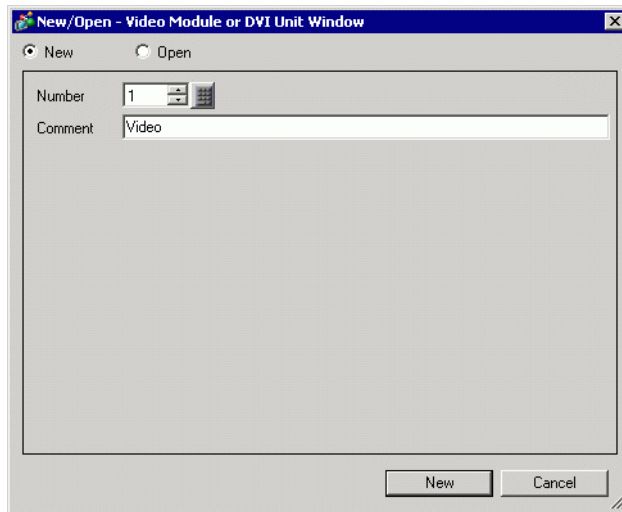

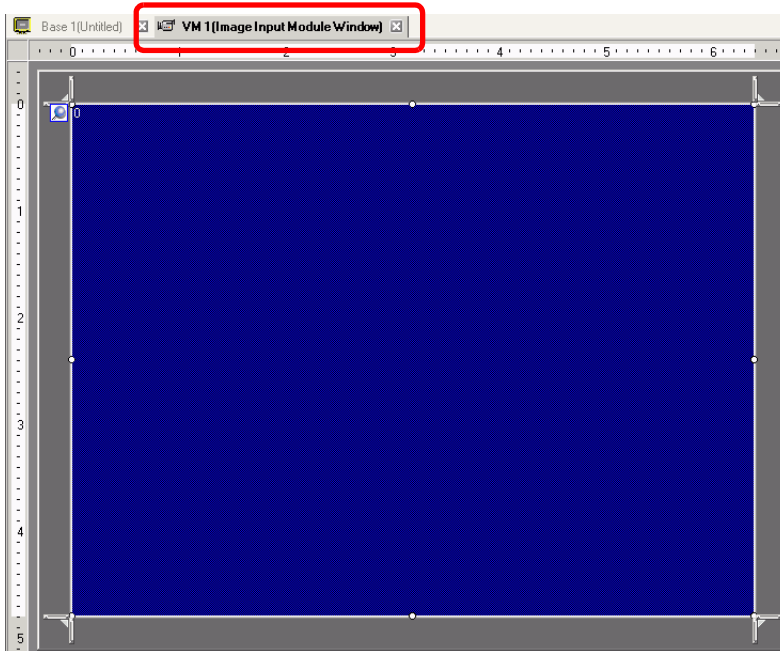

- 4 The video window [VM1] appears.

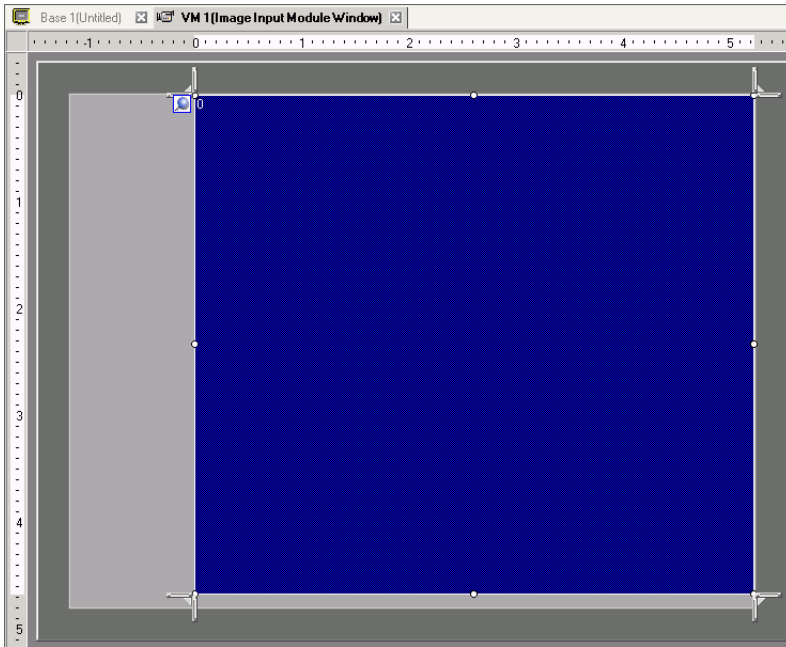

5 Adjust the [Image Input Module Window] size.

To reduce the Window Screens, first reduce the display area (blue parts), then drag the  mark on the four corners to adjust the size. To enlarge, expand the window size and adjust the display area to fit the window size.



6 Double-clicking the display area (the blue part) opens the following dialog box. [Video Layout], click the following icon .

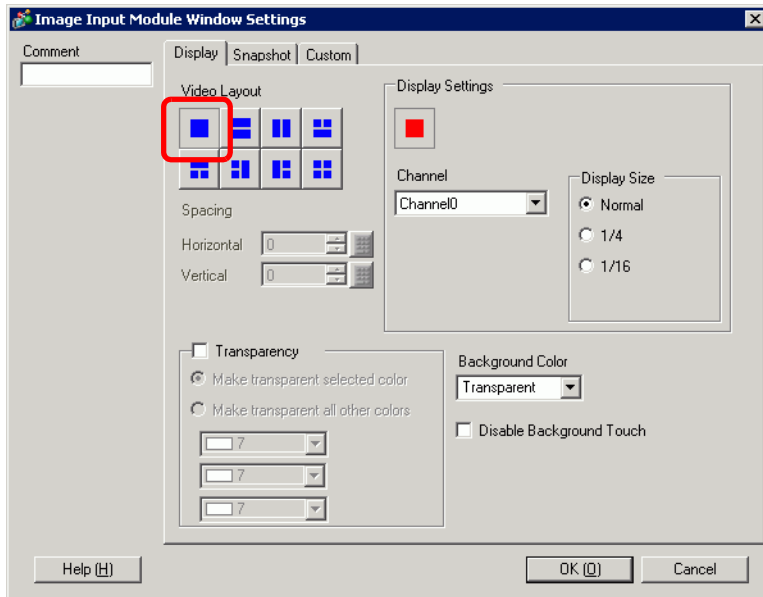

NOTE

- When selecting [DVI Unit], a portion of the items cannot be set. For more details, please refer to the following.
 "27.10.3 Restrictions on DVI Unit Features" (page 27-150)

7 In the [Channel] list, select [RGB(IN)] and set the [Display Size] to [Normal].

NOTE

- If the selected [Display Size] is larger than the display unit or the blue display area, the entire image will not display. You can use [Video Display position] on the [Custom Settings] tab to specify which part of the input image to be displayed. If you want to display the entire image, set the [Display Size] smaller than the size of the blue display area.
- When selecting [DVI Unit], the [Channel] is fixed to [DVI/RGB Input Image].

8 Click [OK] to finish and exit the [Image Input Module Window] settings.

9 Click [Base 1] to switch to the base screen.

On the [Parts (P)] menu, select [Image Input Module Display (V)], or click  to draw the image input module display on the screen.

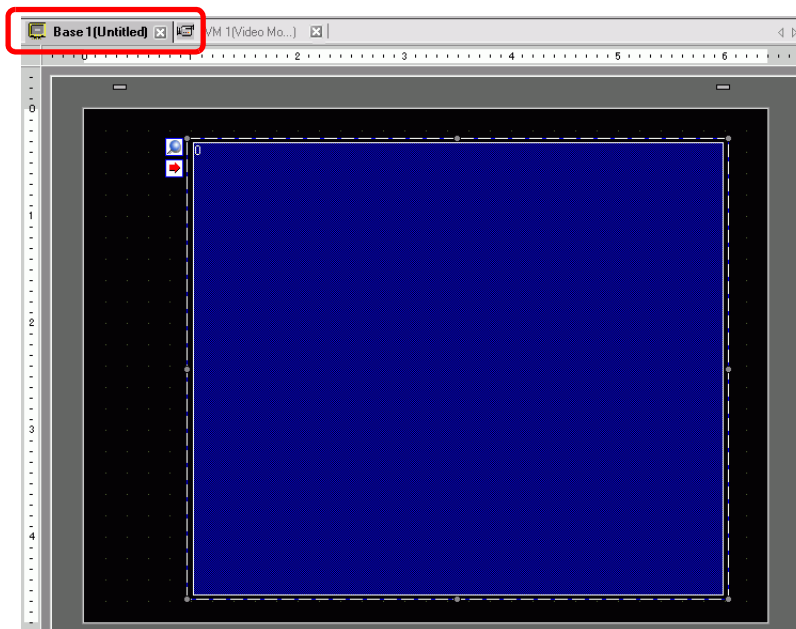

- 10 Double-click the Image Input Module Display. The following dialog box appears.
In the [Video Layout] list, select [Always ON]. In the [Video Number] list, specify the video display number (for example, 1).

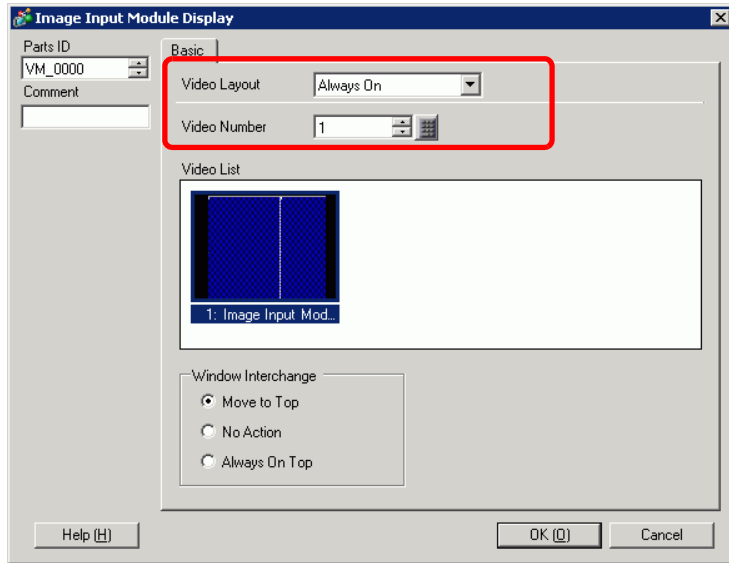

Click [OK] to complete setup.

NOTE

- After you set up the Video Screen, the  icon appears on the [Image Input Module Display]. Click the icon to display the corresponding video screen. This feature is useful for checking or changing the video settings.

27.8 Saving Video Output as Still Images

27.8.1 Introduction

Install the "Video Module Unit" on the AGP-3500T/3510T/3550T/3560T/3600T/3650T/3750T to capture an image from the channel 1 video and save it on the CF Card in JPEG format. In addition to the CF Card, it can be saved in a USB storage device or an FTP server.

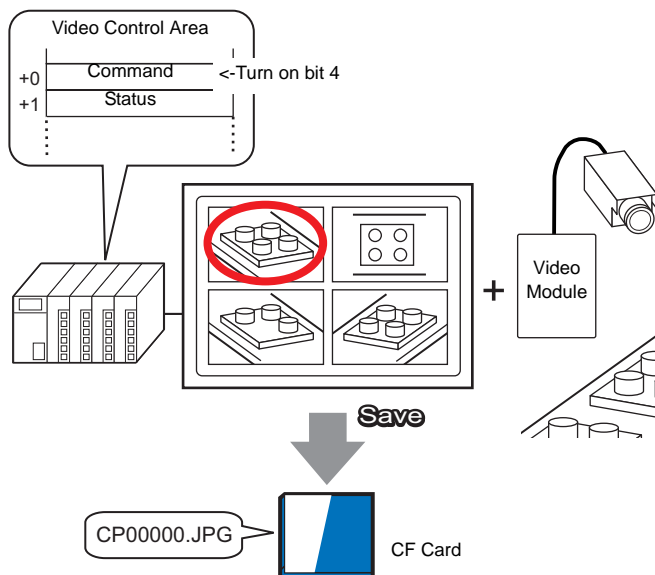
**NOTE**

- You can install the video module for GP3000 series on the AGP-3750T. For other models, you can install video modules for GP2000 or GP3000 series.
- For information about video module specifications and installation, please see "GP2000 Series VM Unit Users Manual" or "GP3000 Series VM Unit Users Manual".

27.8.2 Setup Procedure

NOTE

- Please refer to the Settings Guide for details.
 - ☞ "27.9.6 [Image Input Module] Settings Guide" (page 27-129)
 - ☞ "27.9.5 Common [Image Input Module Window Settings] Settings Guide" (page 27-119)
 - ☞ "27.9.7 Image Input Module Display Settings Guide" (page 27-143)
- Refer to Editing Parts for details about placing parts or setting addresses, shapes, colors, and labels.
 - ☞ "8.6.1 Editing Parts" (page 8-44)

Turn ON the screen capture address on the PLC side to save the specified image from channel 1 as a still image on a CF card in JPEG format. In addition to the CF card, it can be saved in a USB storage device or an FTP server.

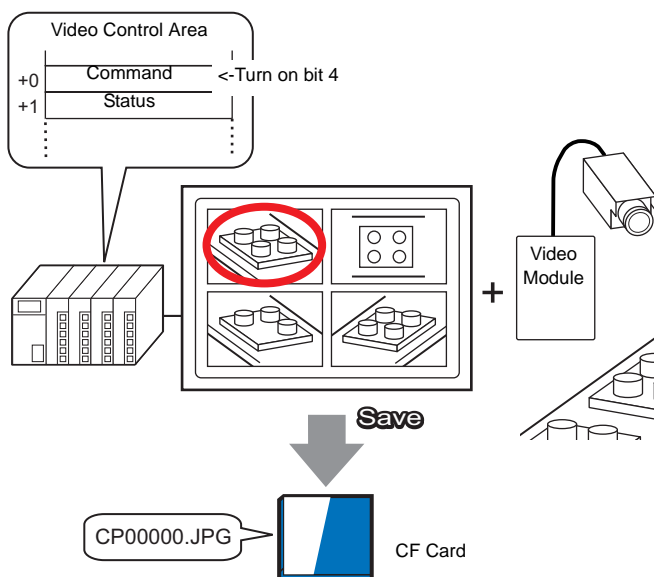

1 In [System Settings], select [Image Input Module].

NOTE

- If the [System Settings] tab is not displayed in the workspace, on the [View (V)] menu, point to [Workspace (W)], and then click [System Settings (S)].

2 Confirm [Image Input Module Settings] is set to [VM Unit (2000)] or [VM Unit (3000)].

Under [Video Control Start Address], select [Enable]. 42 Words from the setup address control the video display.

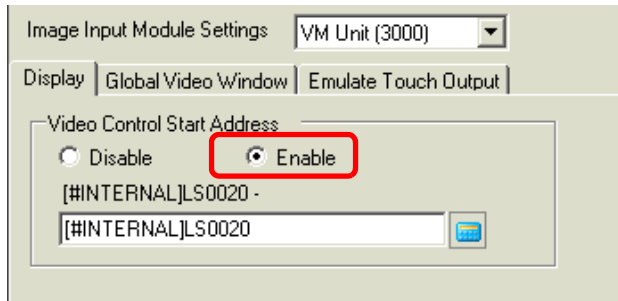

3 Specify the video control start address (for example, LS20).

Click the icon to display an address input keypad.

Select Device "LS", input "20" in the address, and press the "Ent" key.

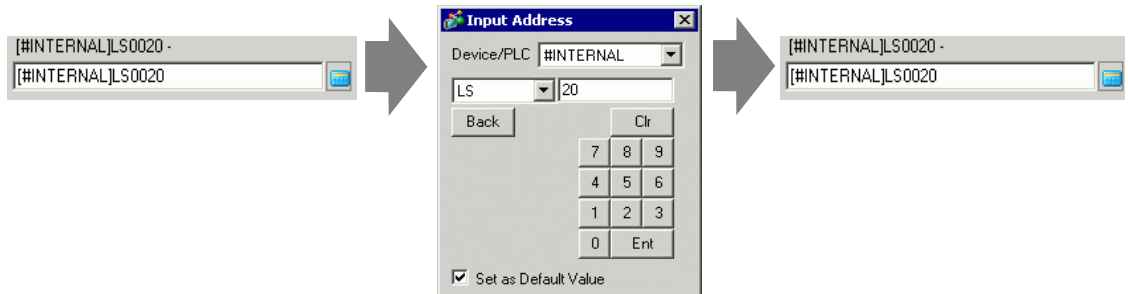

NOTE

- The settings for the [Video Control Start Address] range from LS20 - LS1989 and LS2096 - LS8957. If values outside this range are specified, none of the VM functions will operate.

4 From [Signal], select [NTSC]. In [Signal] select the video signal supported in your region: [NTSC] or [PAL].



- 5 On the [Common Settings (R)] menu, select [Image Input Module Window Settings (U)] or click  to open the following dialog box. Select [New] and then specify [Number] and [Comment]. (For example, Number "1", Comment "Video")

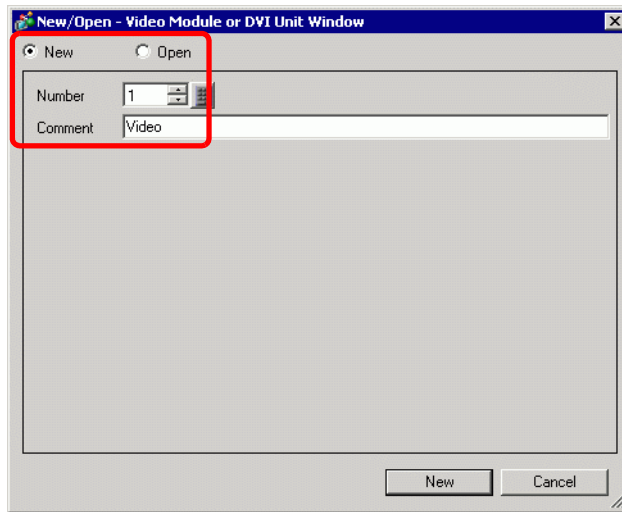

- 6 The video window [VM1] appears.

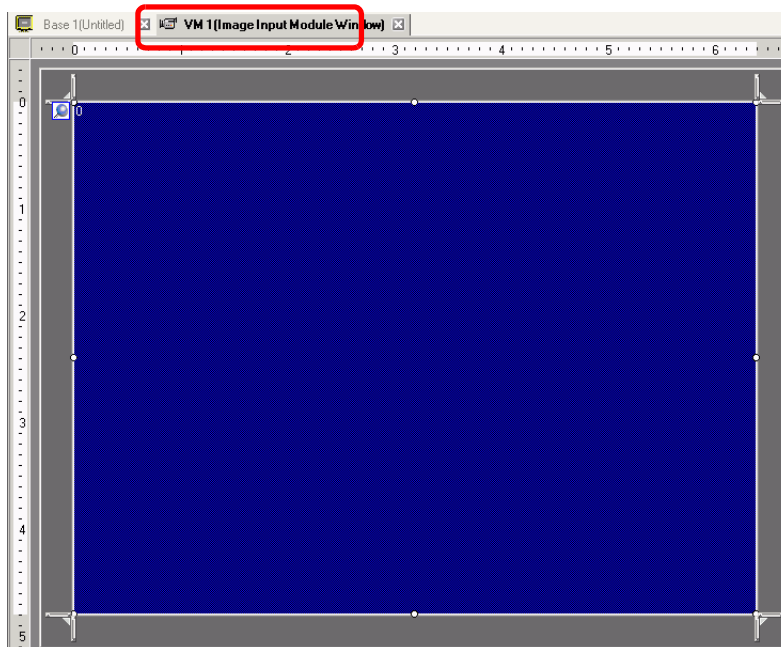

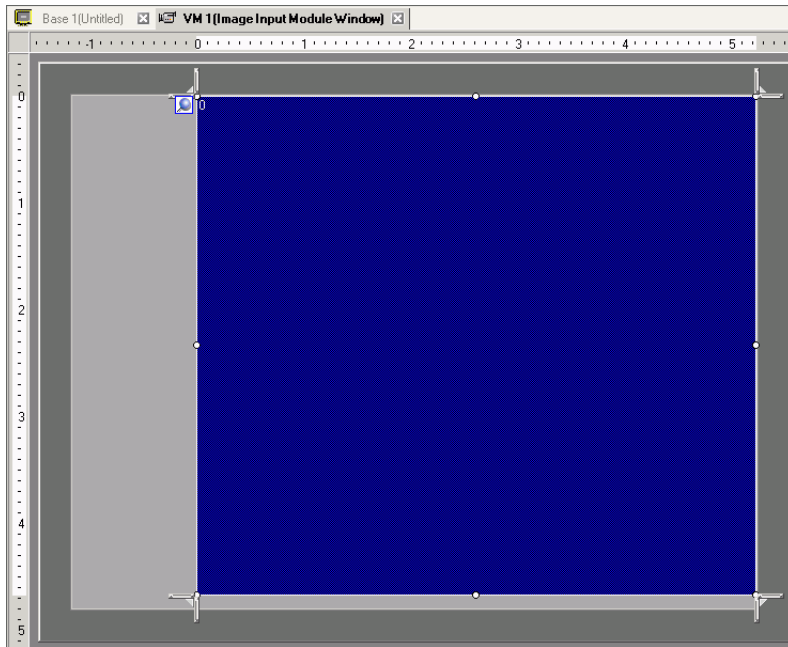

7 Adjust the [Image Input Module Window] size.

To reduce the Window Screens, first reduce the display area (blue parts), then drag the  mark on the four corners to adjust the size. To enlarge, expand the window size and adjust the display area to fit the window size.

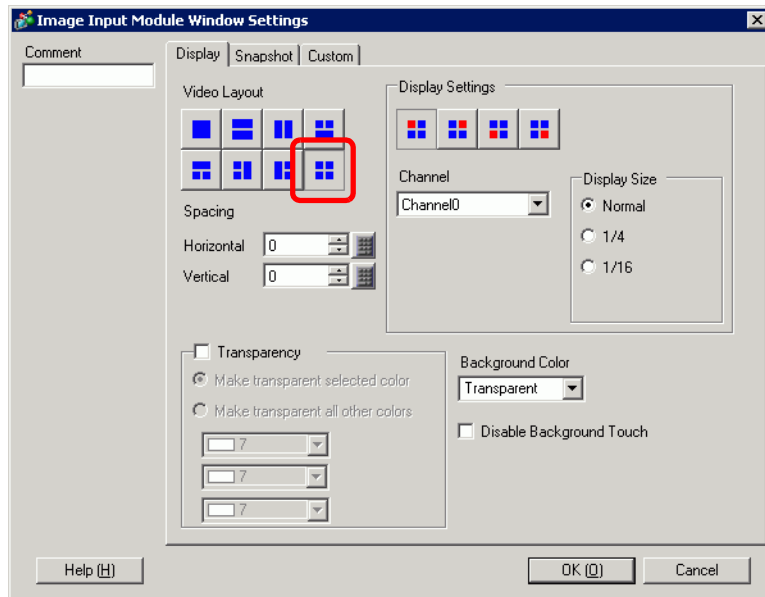

8 Double-click the blue display area. The following dialog box appears. [Video Layout], click the following icon .



- 9 In the [Display] area, click , and under the [Channel], select the camera image to be displayed in this upper left area (for example, Channel 0). Also select the size of the image (for example, 1/4) to be displayed in this area.

Similarly, select the channels and display sizes for the images displayed in the upper right, lower left, and lower right areas.

NOTE

- If the selected [Display Size] is larger than the display unit or the blue display area, the entire image will not display. You can use [Video Display position] on the [Custom Settings] tab to specify which part of the input image to be displayed. If you want to display the entire image, set the [Display Size] smaller than the size of the blue display area.

- 10 Specify the values for the space between the screens. (For example, horizontal 10, vertical 10.) Click [OK] to finish and exit the [Video Module /DVI Unit Window] settings.

NOTE

- You can drag the dots between each screen to adjust the space between screens.

- 11 Open the [Capture] tab, and select the [Video capture] check box.

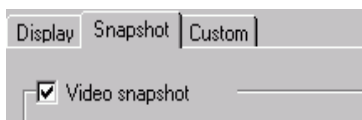

- 12 In the [Channel] list, select [Channel 0].

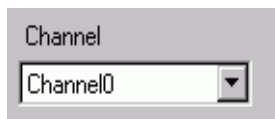
**NOTE**

- You can capture screens for one channel only. You can capture screens only for video images.

- 13 Under [JPG File Number], select [Direct], and specify the JPEG file number for the file you are creating.

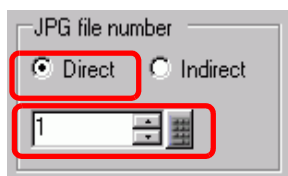
**NOTE**

- Other than the CF card, you can also save to a USB storage device or an FTP server. In the system settings, select [Display Unit] and click the [Mode] tab. In [Screen Capture Settings], select the [Capture Action] check box to select the location to save the file in.

- 14 Click [OK] to exit [Image Input Module Window Settings].
- 15 Open the base screen and on the [Parts (P)] menu select [Image Input Module Display (V)], or click  to place a Image Input Module Display on the screen.

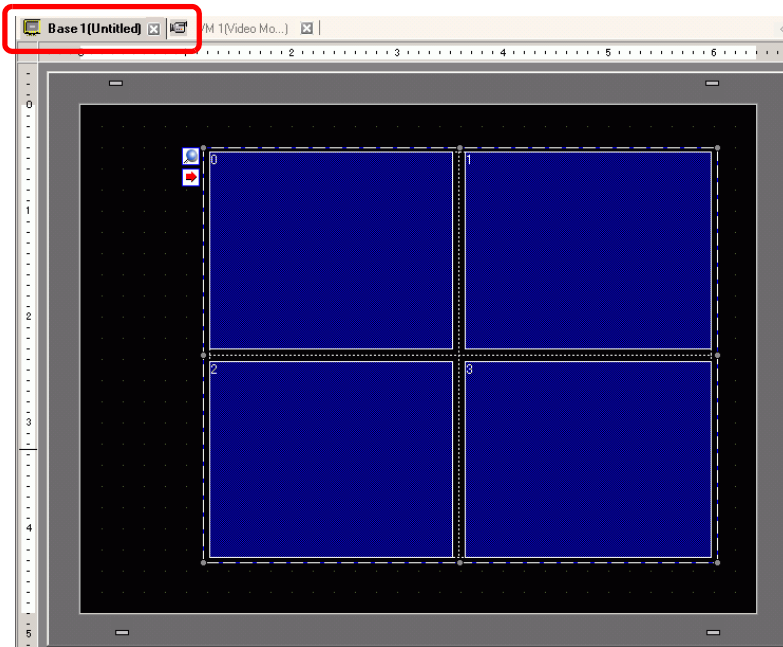

- 16 Double-click the Image Input Module Display. The following dialog box appears. In the [Video Layout] list, select [Always ON], and in the [Video Number] list, specify the video display number (for example, 1) and click [OK].

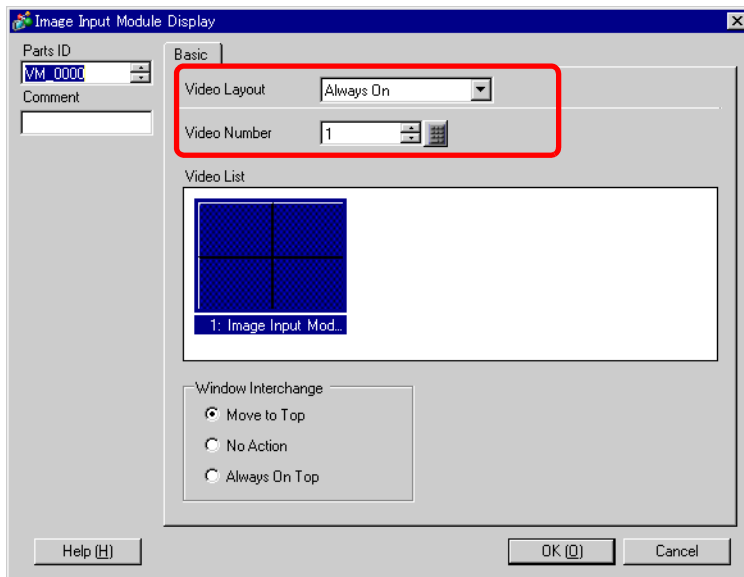

NOTE

- Click the  icon on the [Image Input Module Display] to display the corresponding video screen. This feature is useful for checking the video settings because it makes screen changes easy.

◆ Operating Procedure

- 1 Turn on bit 4 of the [Video Control Start Address] (LS20) specified in step 3.
- 2 The image in channel 0 is captured and saved in the "CAPTURE" folder on the CF card using the file name "CP00001.JPG."

27.9 Settings Guide

27.9.1 [Video/Movie] Settings Guide

Configures the settings for video image display and movie recording.

NOTE

- To check whether this function is available for your model, please refer to the list of supported functions.
 ☞ "1.3 Supported Features" (page 1-5)

■ Basic Settings/Basic

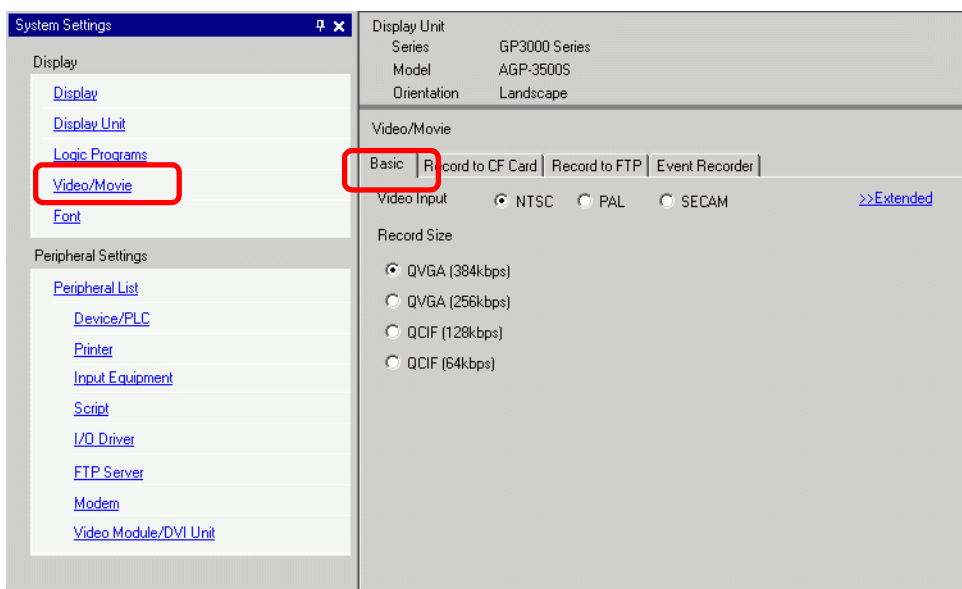

Setting	Description
Video Signal	Select the image input signal. <ul style="list-style-type: none"> • NTSC: 640 x 480 pixels • PAL: 768 x 576 pixels • SECAM: 768 x 576 pixels
Record Size	Select the record size. <ul style="list-style-type: none"> • QVGA (384kbps): 320 x 240 pixels • QVGA (256kbps): 320 x 240 pixels • QCIF (128kbps): 176 x 144 pixels • QCIF (64kbps): 176 x 144 pixels

■ Basic Settings/Details

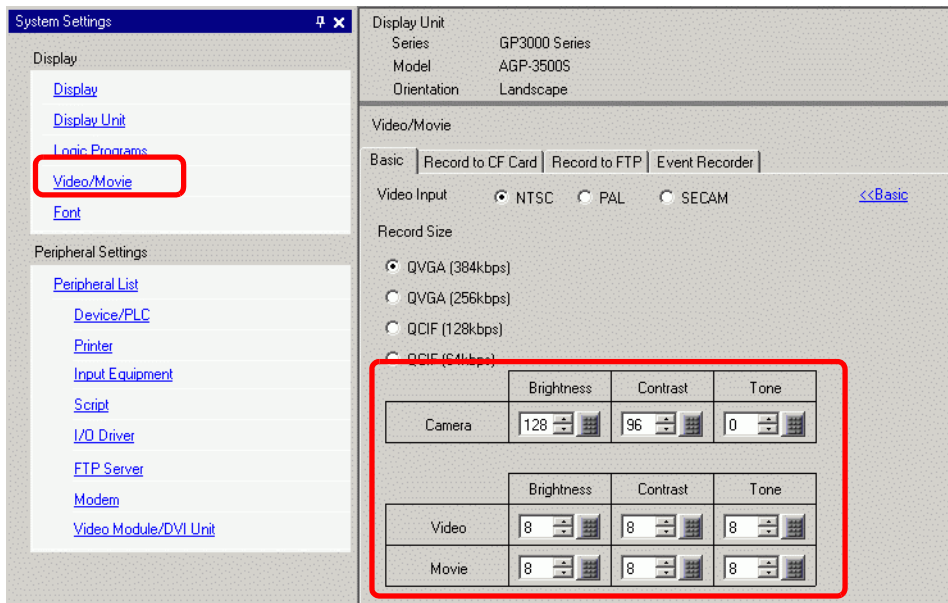

Setting	Description
Camera	Image quality for a video camera connected to GP.
Brightness	Set the brightness. The setting range is 0 to 255 (Low - High).
Contrast	Set the contrast. The setting range is 0 to 255 (Low - High).
Tone	Set the colors. The setting range is 0 to 255 (Green - Red).
Video	Image quality for the real-time display on the GP.
Brightness	Set the brightness. The setting range is 0 to 15 (Low - High).
Contrast	Set the contrast. The setting range is 0 to 15 (Low - High).
Tone	Set the colors. The setting range is 0 to 15 (Green - Red).
Movie	Video quality for playing a movie on the GP.
Brightness	Set the brightness. The setting range is 0 to 15 (Low - High).
Contrast	Set the contrast. The setting range is 0 to 15 (Low - High).
Tone	Set the colors. The setting range is 0 to 15 (Green - Red).

■ Record CF

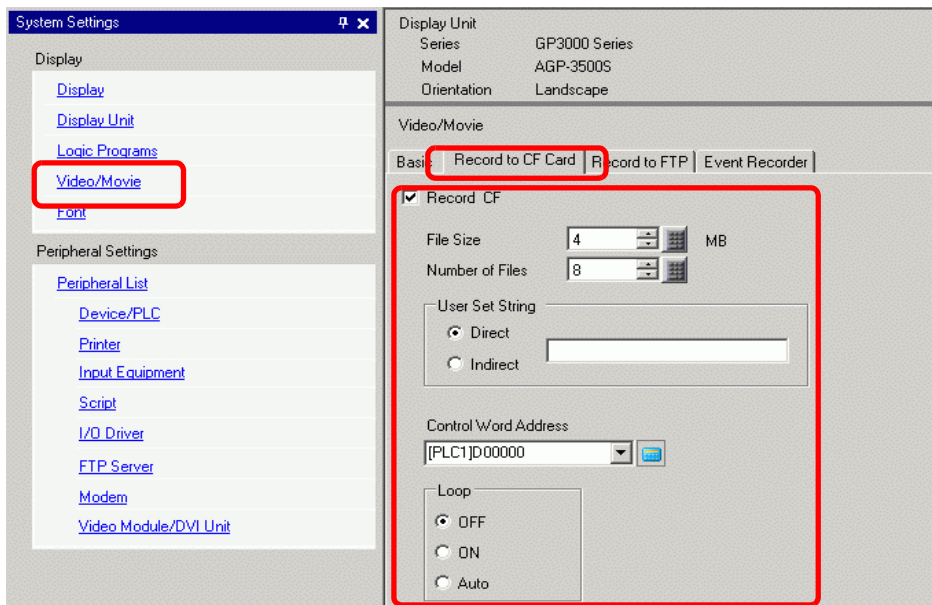

Setting	Description
Record CF	Select whether to record from a video camera and save on a CF Card.
File Size	Specify the size of each movie file to be saved. The settings range is from 1 to 512 MB. Any pictures that exceed the specified file size are automatically saved in the next file. The file name is created based on the time stamp when the save operation begins (year, month, date, hours, minutes, seconds).
Number of Files	Specify the number of video files to save in a folder. The settings range from 1 to 100.
User set string	Specify the character string to be included in the folder and file names for the saved video files. You can specify up to two single-byte alphanumeric characters. <div style="border: 1px solid black; padding: 2px; display: inline-block;">NOTE</div> <ul style="list-style-type: none"> The file name is the user-defined string (maximum two characters) + time stamp. For example, if the user-defined string is "MC", the date is 2006/05/27, and the time is 15:23:46, then the file name is: MC060527_152346.SDX If the user does not specify a string, the folder name will be "NO-NAME" and only the time stamp (year, month, day, hour, minute, second when the file was saved) will appear in the file name.
Direct	Specify the string by entering it here.

Continued

Setting	Description						
Indirect	<p>Specify the address used for saving the file and for specifying the strings as user set strings. You can change any file name on the connection device. Use a sequence of 3 Words from the specified address.</p> <div style="text-align: center;"> <table border="1" style="margin-left: auto; margin-right: auto;"> <tr> <td style="padding: 2px;">+0</td> <td style="padding: 2px;">Control</td> </tr> <tr> <td style="padding: 2px;">+1</td> <td style="padding: 2px;">User set string</td> </tr> <tr> <td style="padding: 2px;">+2</td> <td style="padding: 2px;">Status</td> </tr> </table> </div>	+0	Control	+1	User set string	+2	Status
+0	Control						
+1	User set string						
+2	Status						
User Set String	<ul style="list-style-type: none"> • Control Turn ON bit 0 to save the codes in the following address as "user set string". <div style="text-align: center; margin-bottom: 20px;"> </div> <ul style="list-style-type: none"> • User Set String Save the string codes. The procedure for saving text codes differs depending on the connection devices. • Status Turning ON bit 0 in the [Control] address also turns ON bit 0 in the [Status] address. Specifying user set strings while saving to the CF Card is in progress will result in an error and bit 15 will turn ON. <div style="text-align: center;"> </div> <div style="margin-top: 20px;"> <p>NOTE</p> <ul style="list-style-type: none"> • Bit 0 and bit 15 of the [Status] address are turned OFF when bit 0 of the [Control] address is turned OFF. • If a 32-bit device is specified, only the bottom 16 bits are used. </div>						

Continued

Setting	Description						
<p>Control Word Address</p>	<p>Specify the address for controlling save operations. Use a sequence of 3 Words from the specified address.</p> <div style="text-align: center;"> <table border="1" style="margin-left: auto; margin-right: auto;"> <tr> <td style="padding: 2px;">+0</td> <td style="padding: 2px;">Control</td> </tr> <tr> <td style="padding: 2px;">+1</td> <td style="padding: 2px;">Status</td> </tr> <tr> <td style="padding: 2px;">+2</td> <td style="padding: 2px;">Number of Files Saved</td> </tr> </table> </div> <ul style="list-style-type: none"> <p>Control Turn ON bit 0 to start recording (and saving on CF Card). Turn OFF the bit to stop recording.</p> <p>☞ " ◆ Timing Chart for Saving on CF" (page 27-81)</p> <div style="display: flex; align-items: center; justify-content: center;"> <div style="text-align: center; margin-right: 20px;"> <p>15</p> <div style="border: 1px solid black; width: 150px; height: 15px; margin: 0 auto;"></div> <p>Resume Bit 0 ->1 Resume Request</p> </div> <div style="text-align: center; margin-right: 20px;"> <p>0</p> <div style="border: 1px solid black; width: 15px; height: 15px; margin: 0 auto;"></div> <p>Save Trigger Bit 0 -> 1 Start 1 ->0 Stop</p> </div> </div> 	+0	Control	+1	Status	+2	Number of Files Saved
+0	Control						
+1	Status						
+2	Number of Files Saved						

Continued

Setting	Description																														
<p>Control Word Address</p>	<ul style="list-style-type: none"> Status The CF save status and error status are saved. <div style="text-align: center; margin: 10px 0;"> </div> <p>Save authorization bits are turned ON when the GP power is turned on. The error status indicates the following conditions.</p> <p>(Error Code)</p> <table border="1" style="width: 100%; border-collapse: collapse;"> <thead> <tr> <th>Bit</th> <th>Code</th> <th>Description</th> </tr> </thead> <tbody> <tr> <td>0</td> <td>Completed Successfully</td> <td>—</td> </tr> <tr> <td>1 to 3</td> <td>Reserved</td> <td>—</td> </tr> <tr> <td>4</td> <td>No CF Card</td> <td>The CF Card is not inserted in the GP, or the CF Card cover is not closed.</td> </tr> <tr> <td>5</td> <td>CF Write Error</td> <td>Writing to the CF Card failed or there is not enough free space.</td> </tr> <tr> <td>6</td> <td>Reserved</td> <td>—</td> </tr> <tr> <td>7</td> <td>CF Card Error</td> <td>CF Card is invalid or unformatted, or the media inserted is not a CF Card.</td> </tr> <tr> <td>8 to 13</td> <td>Reserved</td> <td>—</td> </tr> <tr> <td>14</td> <td>Playing</td> <td>Saving to CF was initiated while movie play was in progress.</td> </tr> <tr> <td>15</td> <td>Reserved</td> <td>—</td> </tr> </tbody> </table> <ul style="list-style-type: none"> Number of Files Saved If a file is successfully saved, the address is increased by one. You can see how many files have been saved up to that point. Files currently being saved are not counted. The number of files are updated when; <ul style="list-style-type: none"> - The power is turned on - A CF Card is inserted - [Indirect] is selected when setting the [User Set String], or the folder name is changed. Only movie files (.SDX) are counted. <p>IMPORTANT</p> <ul style="list-style-type: none"> Do not save files in a folder that does not have the same [User Set String] or file name word count, as doing so will cause the files to be included in the file count number. <p>NOTE</p> <ul style="list-style-type: none"> If a 32-bit device is specified, only the bottom 16 bits are used. 	Bit	Code	Description	0	Completed Successfully	—	1 to 3	Reserved	—	4	No CF Card	The CF Card is not inserted in the GP, or the CF Card cover is not closed.	5	CF Write Error	Writing to the CF Card failed or there is not enough free space.	6	Reserved	—	7	CF Card Error	CF Card is invalid or unformatted, or the media inserted is not a CF Card.	8 to 13	Reserved	—	14	Playing	Saving to CF was initiated while movie play was in progress.	15	Reserved	—
Bit	Code	Description																													
0	Completed Successfully	—																													
1 to 3	Reserved	—																													
4	No CF Card	The CF Card is not inserted in the GP, or the CF Card cover is not closed.																													
5	CF Write Error	Writing to the CF Card failed or there is not enough free space.																													
6	Reserved	—																													
7	CF Card Error	CF Card is invalid or unformatted, or the media inserted is not a CF Card.																													
8 to 13	Reserved	—																													
14	Playing	Saving to CF was initiated while movie play was in progress.																													
15	Reserved	—																													

Continued

Setting	Description
Loop	Set the operation to be initiated after the movie files have been saved as specified in [Number of Files].
Disable	After all the specified files have been saved (the MAX bit is turned ON), no more files can be saved. To resume saving, delete movie files or specify files saved in another folder and turn ON the resume bit. The MAX bit turns OFF.
Enable	After all the specified files have been saved (the MAX bit is turned ON), no more files can be saved. When the resume bit is turned ON, the oldest file is deleted and a new file is saved.
Auto	Once all the specified files have been saved (the MAX bit is turned ON), the files are deleted starting with the oldest file, and new files are saved.

◆ Timing Chart for Saving on CF

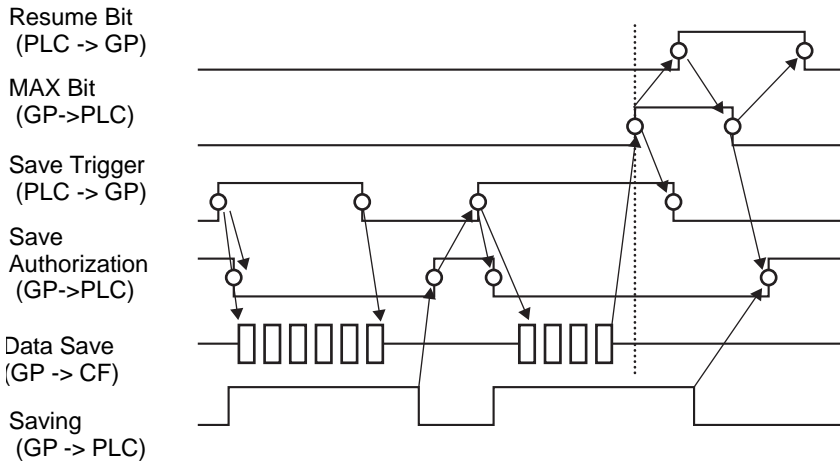

NOTE

- Bit 1 (resume bit) of the [Control] address does not automatically turn OFF. Confirm that bit 2 (MAX bit) of the [Status] address is turned OFF and then turn OFF the resume bit.

■ FTP Save

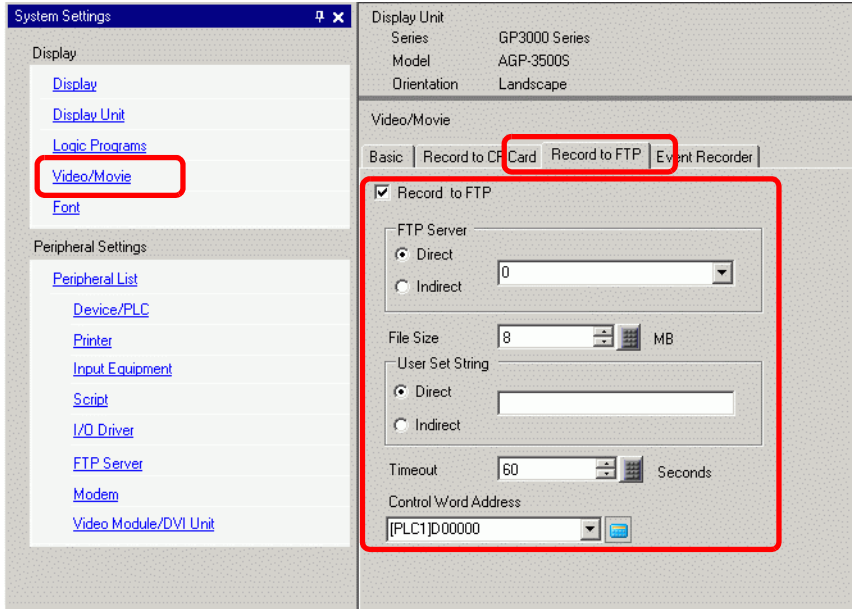

Setting	Description									
Record to FTP	Set whether to record from a video camera and save on an FTP server.									
FTP server	Specify the FTP server for saving the movie files. Use the FTP server number registered in [FTP Server] in the system setting window.									
Direct	Select the FTP server number from 0-31.									
Indirect	<p>Specify the address for saving, and specify the connection number for the server on which the files will be saved. You can change the FTP server for saving files on the connection device. Use a sequence of 3 Words from the specified address.</p> <div style="text-align: center;"> <table border="1" style="margin-left: auto; margin-right: auto;"> <tr> <td style="padding: 2px;">+0</td> <td style="padding: 2px;">Control</td> </tr> <tr> <td style="padding: 2px;">+1</td> <td style="padding: 2px;">Server Connection Number</td> </tr> <tr> <td style="padding: 2px;">+2</td> <td style="padding: 2px;">Status</td> </tr> </table> </div> <ul style="list-style-type: none"> • Control Turn ON bit 0 to specify the numbers saved in the following address as the FTP server connection. <div style="text-align: center;"> <table border="1" style="margin-left: auto; margin-right: auto;"> <tr> <td style="padding: 2px;">15</td> <td style="width: 100px; height: 20px;"></td> <td style="padding: 2px;">0</td> </tr> </table> <p style="text-align: right; margin-right: 50px;">↑ Server Connection Number Set Bit 0->1 Start</p> </div> <ul style="list-style-type: none"> • Server Connection Number Store the server connection number. Store it before turning ON bit 0 of the [Control] address. 	+0	Control	+1	Server Connection Number	+2	Status	15		0
+0	Control									
+1	Server Connection Number									
+2	Status									
15		0								

Continued

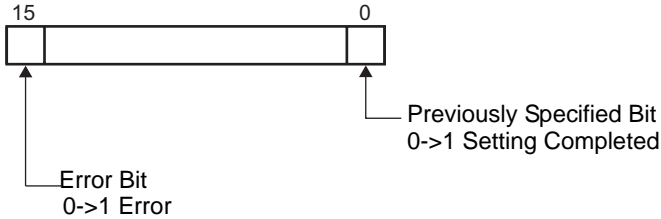
Setting		Description
FTP Server	Indirect	<ul style="list-style-type: none"> • Status Turning ON bit 0 in the [Control] address also turns ON bit 0 in the [Status] address. Specifying the server connection number while saving is in progress results in an error and bit 15 turns ON.  <p>The diagram shows a horizontal bar representing a 16-bit register. The leftmost bit is labeled '15' and has an arrow pointing to it from the text 'Error Bit 0->1 Error'. The rightmost bit is labeled '0' and has an arrow pointing to it from the text 'Previously Specified Bit 0->1 Setting Completed'.</p> <p>NOTE</p> <ul style="list-style-type: none"> • Bit 0 and bit 15 of the [Status] address are turned OFF when bit 0 of the [Control] address is turned OFF. • If a 32-bit device is specified, only the bottom 16 bits are used.
	File Size	Specify the size of each movie file to be saved. The settings range is from 1 to 2048 MB. Any pictures that exceed the specified file size are automatically saved in the next file. The file name is created based on the time stamp when the save operation begins (year, month, date, hours, minutes, seconds).
User set string		Specify the character string to be included in the folder and file names for the saved video files. You can specify up to two single-byte alphanumeric characters. <p>NOTE</p> <ul style="list-style-type: none"> • The file name is the user-defined string (maximum two characters) + time stamp. For example, if the user-defined string is "MC", the date is 2006/05/27, and the time is 15:23:46, then the file name is: "MC060527_152346.SDX"
	Direct	Directly input the settings.

Continued

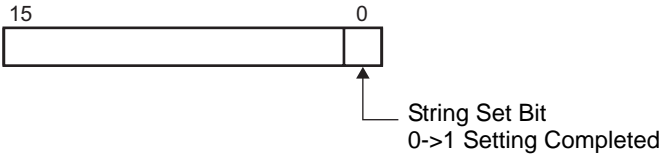
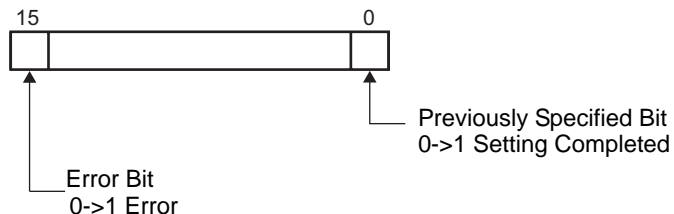
Setting	Description						
<p style="writing-mode: vertical-rl; transform: rotate(180deg);">User Set String</p> <p style="text-align: center;">Indirect</p>	<p>Specify the address used for saving the file and for specifying the strings as user set strings. You can change any file name on the connection device. Use a sequence of three Words from the specified address.</p> <div style="text-align: center;"> <table border="1" style="margin-left: auto; margin-right: auto;"> <tr><td>+0</td><td>Control</td></tr> <tr><td>+1</td><td>User set string</td></tr> <tr><td>+2</td><td>Status</td></tr> </table> </div> <ul style="list-style-type: none"> Control Turn ON bit 0 to save the codes in the following address as "user set string". <div style="text-align: center; margin-top: 10px;">  </div> User Set String Save the string codes. The procedure for saving text codes differs depending on the connection devices. Status Turning ON bit 0 in the [Control] address also turns ON bit 0 in the [Status] address. Specifying user set strings while saving is in progress results in an error and bit 15 turns ON. <div style="text-align: center; margin-top: 10px;">  </div> <div style="margin-top: 20px;"> <p>NOTE</p> <ul style="list-style-type: none"> Bit 0 and bit 15 of the [Status] address are turned OFF when bit 0 of the [Control] address is turned OFF. If a 32-bit device is specified, only the bottom 16 bits are used. </div>	+0	Control	+1	User set string	+2	Status
+0	Control						
+1	User set string						
+2	Status						
<p>Time out</p>	<p>Specify the queuing time for when the FTP server does not respond to an access request. The value can be from 10 to 120 seconds.</p>						

Continued

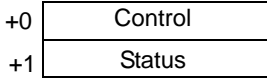
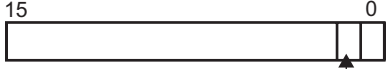
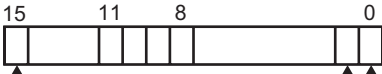
Setting	Description																								
Control Word Address	<p>Specify the address for controlling save operations. Use a sequence of two words from the specified address.</p> <div style="text-align: center;">  </div> <ul style="list-style-type: none"> • Control Turn ON bit 0 to start recording (start saving to FTP). Turn OFF the bit to stop recording. ☞ "Timing Chart for Saving to ♦ FTP" (page 27-86) <div style="text-align: center;">  </div> <div style="display: flex; justify-content: space-around;"> <div style="text-align: center;"> <p>Resume Bit 0 ->1 Resume Request</p> </div> <div style="text-align: center;"> <p>Save Trigger Bit 0 -> 1 Start 1 ->0 Stop</p> </div> </div>																								
Control Word Address	<ul style="list-style-type: none"> • Status The FTP save and error status are saved. <div style="text-align: center;">  </div> <div style="display: flex; justify-content: space-around;"> <div style="text-align: center;"> <p>Error Bit 0->1 Error</p> </div> <div style="text-align: center;"> <p>Saving Bit 0 Stopped 1 Saving</p> </div> <div style="text-align: center;"> <p>Save authorization bit 0 Save Not Permitted 1 Save Permitted</p> </div> </div> <p>Save authorization bits are turned ON when the GP power is turned on. The error status indicates the following conditions.</p> <p>(Error Code)</p> <table border="1" style="width: 100%; border-collapse: collapse;"> <tbody> <tr> <td style="text-align: center;">0</td> <td>Completed Successfully</td> <td style="text-align: center;">-</td> </tr> <tr> <td style="text-align: center;">1 to 8</td> <td>Reserved</td> <td style="text-align: center;">-</td> </tr> <tr> <td style="text-align: center;">9</td> <td>FTP Connection Error</td> <td>The FTP server is not operating normally, or the FTP server does not exist.</td> </tr> <tr> <td style="text-align: center;">10</td> <td>FTP Login Error</td> <td>The FTP user name or password is incorrect.</td> </tr> <tr> <td style="text-align: center;">11</td> <td>Write Error</td> <td>The logged in user does not have writing privileges, or writing to the FTP server has failed, or there is not enough free space.</td> </tr> <tr> <td style="text-align: center;">12 to13</td> <td>Reserved</td> <td style="text-align: center;">-</td> </tr> <tr> <td style="text-align: center;">14</td> <td>Client functions are operating</td> <td>Saving to FTP server was initiated while movie play was in progress.</td> </tr> <tr> <td style="text-align: center;">15</td> <td>Reserved</td> <td style="text-align: center;">-</td> </tr> </tbody> </table> <div style="border: 1px solid black; padding: 2px; margin-top: 10px;">NOTE</div> <ul style="list-style-type: none"> • If a 32-bit device is specified, only the bottom 16 bits are used. 	0	Completed Successfully	-	1 to 8	Reserved	-	9	FTP Connection Error	The FTP server is not operating normally, or the FTP server does not exist.	10	FTP Login Error	The FTP user name or password is incorrect.	11	Write Error	The logged in user does not have writing privileges, or writing to the FTP server has failed, or there is not enough free space.	12 to13	Reserved	-	14	Client functions are operating	Saving to FTP server was initiated while movie play was in progress.	15	Reserved	-
0	Completed Successfully	-																							
1 to 8	Reserved	-																							
9	FTP Connection Error	The FTP server is not operating normally, or the FTP server does not exist.																							
10	FTP Login Error	The FTP user name or password is incorrect.																							
11	Write Error	The logged in user does not have writing privileges, or writing to the FTP server has failed, or there is not enough free space.																							
12 to13	Reserved	-																							
14	Client functions are operating	Saving to FTP server was initiated while movie play was in progress.																							
15	Reserved	-																							

Continued

Timing Chart for Saving to ◆FTP

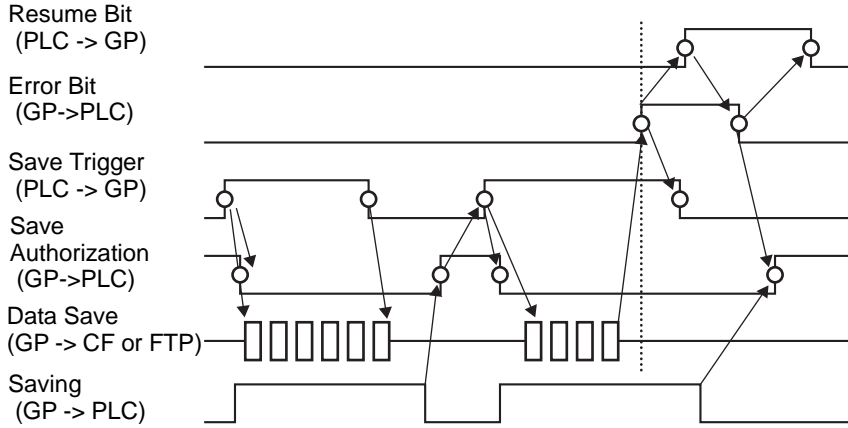

- NOTE**
- If saving a file to the FTP server fails, the GP turns ON bit 15 of the [Status] address (save error bit) and no files can be saved. Once the FTP server resumes file saving, the GP turns ON bit 1 (resume bit) of the [Control] address. The GP turns OFF the error bit and begins saving files.

■ Event Recorder

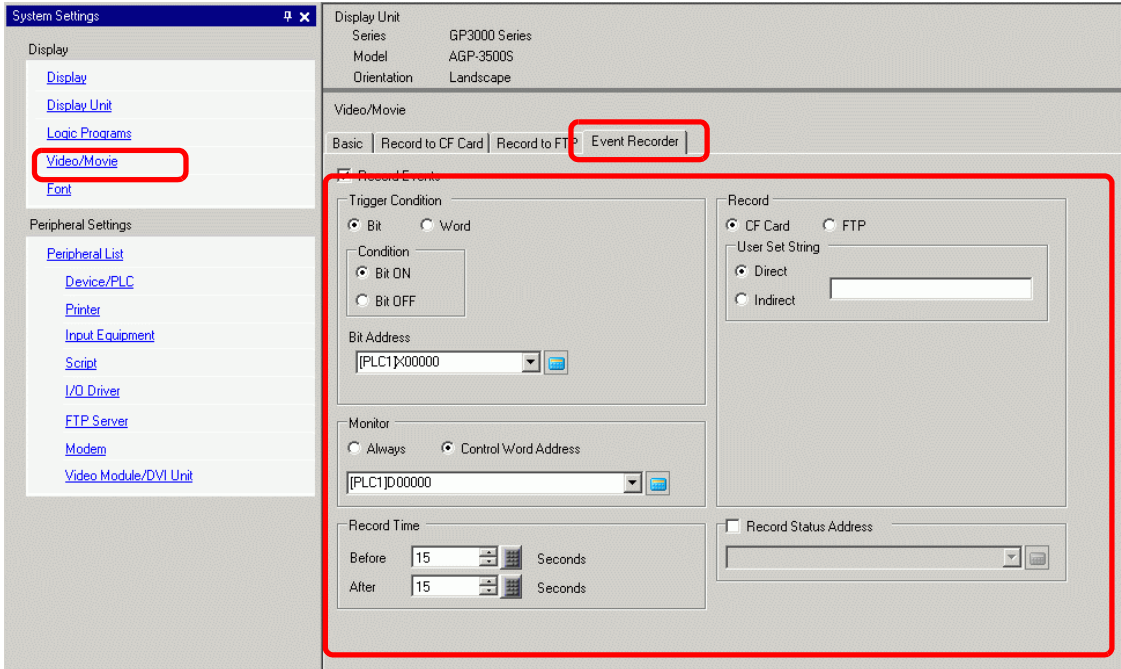

Setting	Description
Record Events	Specify whether to use the "event recorder" function for recording pictures before and after a specific event if the specified conditions are met.
Trigger	Specify the operational conditions for the event recorder function.
Bit	Control saving with the specified bit address.
Condition	
Bit ON	Start saving with the bit ON.
Bit OFF	Start saving with the bit OFF.
Bit Address	Specify the control bit address for saving.
Word	Control the saving operation with a value from the specified word address.
	<div style="border: 1px solid black; padding: 2px; display: inline-block;">NOTE</div> <ul style="list-style-type: none"> • 16 bits, Unsigned, and BIN is the only format supported.

Continued

Setting		Description		
Trigger	Word	Condition	Match	Saving starts when the value in the settings matches the value on the PLC. <ul style="list-style-type: none"> Number: Specify the value in the settings.
			Different	Saving starts when the value in the settings differs from the value on the PLC. <ul style="list-style-type: none"> Number: Specify the value in the settings.
			Inside Range	Saving starts when the value in the settings falls in the range of values on the PLC. The setup values are included. <ul style="list-style-type: none"> Minimum: Set the minimum value from 0 to 65534. Maximum: Set the maximum value from 1 to 65535.
			Out of range	Saving starts when the setting value is out of the PLC value range. The setup values are included. <ul style="list-style-type: none"> Minimum: Set the minimum value from 0 to 65534. Maximum: Set the maximum value from 1 to 65535.
	Word Address	Specify the Word address for controlling saving operations.		
Monitor		Set the monitoring conditions.		
Always On		The monitoring event recorder is always ON, and the movie player is unavailable.		
Control Word Address		<p>Specify the control address for monitoring operations. Use a sequence of two Words from the specified address. Trigger save is available only when monitoring.</p> <div style="text-align: center;"> </div> <ul style="list-style-type: none"> Control Turn ON bit 0 to start monitoring. Turn OFF the bit to stop monitoring. " ◆ Event Recorder Timing Chart" (page 27-94) <div style="text-align: center;"> <p>Resume Bit 0 ->1 Resume Request</p> <p>Monitor Start Trigger Bit 0 -> 1 Start 1 -> 0 Stop</p> </div> <ul style="list-style-type: none"> Monitor Status The CF save status and error status are saved. <div style="text-align: center;"> <p>Monitoring Bit 0 Stopped 1 Monitoring</p> <p>Monitor Start Error Bit 0 ->1 Start Error</p> </div>		

Continued

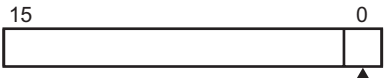
Setting	Description						
Record Time	<p>Specify the time for the record. The value can be from 1 to 60 seconds.</p> <ul style="list-style-type: none"> • Before: Specify the recording time before the trigger. • After: Specify the recording time after the trigger. <p>NOTE</p> <ul style="list-style-type: none"> • The recording time is a total of the time set above. 						
Save in	Set where to save a movie file.						
CF	Save the file on CF Card.						
User set string	<p>Specify the character string to be included in the folder and file names for the saved video files. You can specify up to two single-byte alphanumeric characters.</p> <p>NOTE</p> <ul style="list-style-type: none"> • In "\MOVIE," a folder named with the specified string is created for the saved files. • The file name is saved using the user-defined string (two characters) + time stamp. For example, if the user-defined string is "MC", the date is 2006/05/27, and the time is 15:23:46, then the file name is: MC060527_152346.SDX • When there is no string set, the folder name is "\MOVIE\NONAME" and only the time stamp (year, month, day, hour, minute, and second when the file is saved on) is used for the file name. 						
Direct	Specify the string by entering it here.						
Indirect	<p>Specify the address used for saving the file and for specifying the strings as user set strings. You can change any file name on the connection device. Use a sequence of 3 Words from the specified address.</p> <div style="text-align: center;"> <table border="1" style="margin-left: auto; margin-right: auto;"> <tr> <td style="padding: 2px;">+0</td> <td style="padding: 2px;">Control</td> </tr> <tr> <td style="padding: 2px;">+1</td> <td style="padding: 2px;">User set string</td> </tr> <tr> <td style="padding: 2px;">+2</td> <td style="padding: 2px;">Status</td> </tr> </table> </div> <ul style="list-style-type: none"> • Control Turn ON bit 0 to save the codes in the following address as "user set string". <div style="text-align: center;">  <p style="margin-left: 100px;">15 0</p> <p style="margin-left: 100px;">↑ String Set Bit 0->1 Setting Completed</p> </div> <ul style="list-style-type: none"> • User Set String Save the string codes. The procedure for saving text codes differs depending on the connection devices. 	+0	Control	+1	User set string	+2	Status
+0	Control						
+1	User set string						
+2	Status						

Continued

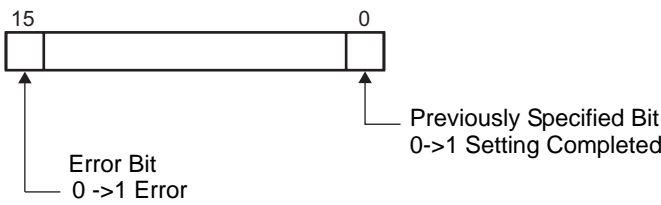
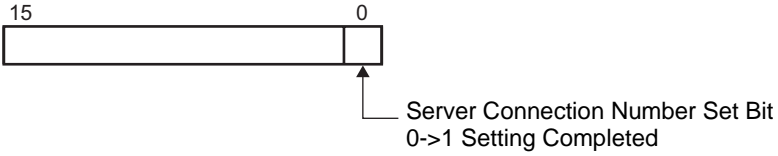
Setting			Description				
Save in	CF	User Set String	<ul style="list-style-type: none"> • Status Turning ON bit 0 in the [Control] address also turns ON bit 0 in the [Status] address. Specifying user set strings while saving to the CF Card is in progress will result in an error and bit 15 will turn ON.  <p>NOTE</p> <ul style="list-style-type: none"> • Bit 0 and bit 15 of the [Status] address are turned OFF when bit 0 of the [Control] address is turned OFF. • If a 32-bit device is specified, only the bottom 16 bits are used. 				
		Indirect	<p>Save to the FTP server.</p>				
	FTP Server	<p>Direct</p> <p>Select the FTP server number from 0-31.</p> <p>Specify the address for saving, and specify the connection number for the server on which the files will be saved. You can change the FTP server for saving files on the connection device. Use a sequence of 3 Words from the specified address.</p> <table border="1" data-bbox="596 966 960 1081"> <tr> <td>+0</td> <td>Control</td> </tr> <tr> <td>+1</td> <td>Server Connection Number</td> </tr> <tr> <td>+2</td> <td>Status</td> </tr> </table> <ul style="list-style-type: none"> • Control Turn ON bit 0 to specify the numbers saved in the following address as the FTP server connection.  <ul style="list-style-type: none"> • Server Connection Number Store the server connection number. Store it before turning ON bit 0 of the [Control] address. 	+0	Control	+1	Server Connection Number	+2
+0	Control						
+1	Server Connection Number						
+2	Status						
Indirect							

Continued

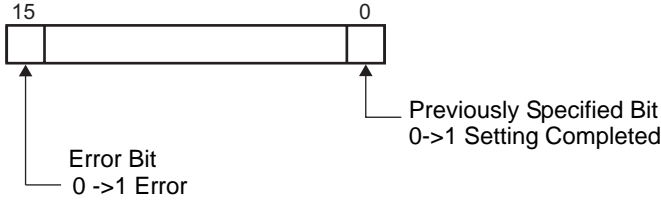
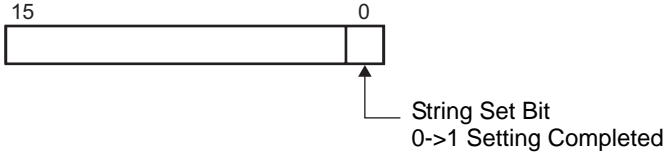
Setting		Description					
Save in	FTP Server	<ul style="list-style-type: none"> • Status Turning ON bit 0 in the [Control] address also turns ON bit 0 in the [Status] address. Specifying the server connection number while saving is in progress results in an error and bit 15 turns ON.  <p>NOTE</p> <ul style="list-style-type: none"> • Bit 0 and bit 15 of the [Status] address are turned OFF when bit 0 of the [Control] address is turned OFF. • If a 32-bit device is specified, only the bottom 16 bits are used. 					
	FTP	<p>User set string</p> <p>Specify the character string to be included in the folder and file names for the saved video files. You can specify up to two single-byte alphanumeric characters.</p> <p>NOTE</p> <ul style="list-style-type: none"> • The file name is the user-defined string (maximum two characters) + time stamp. For example, if the user-defined string is "MC", the date is 2006/05/27, and the time is 15:23:46, then the file name is: "MC060527_152346.SDX" 					
	Indirect	<p>Directly input the settings.</p> <p>Specify the address used for saving the file and for specifying the strings as user set strings. You can change any file name on the connection device. Use a sequence of three Words from the specified address.</p> <table border="1" style="margin-left: auto; margin-right: auto;"> <tr> <td>+0</td> <td>Control</td> </tr> <tr> <td>+1</td> <td>User set string</td> </tr> <tr> <td>+2</td> <td>Status</td> </tr> </table> <ul style="list-style-type: none"> • Control Turn ON bit 0 to save the codes in the following address as "user set string".  <ul style="list-style-type: none"> • User Set String Save the string codes. The procedure for saving text codes differs depending on the connection devices. 	+0	Control	+1	User set string	+2
+0	Control						
+1	User set string						
+2	Status						

Continued

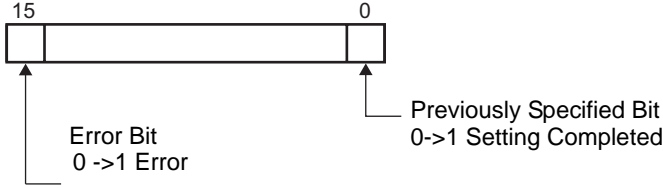
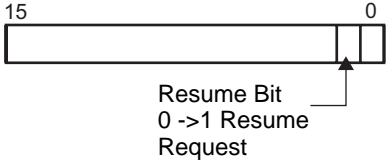
Setting				Description			
Save in	FTP	User Set String	Indirect	<ul style="list-style-type: none"> • Status Turning ON bit 0 in the [Control] address also turns ON bit 0 in the [Status] address. Specifying user set strings while saving is in progress results in an error and bit 15 turns ON.  <p>NOTE</p> <ul style="list-style-type: none"> • Bit 0 and bit 15 of the [Status] address are turned OFF when bit 0 of the [Control] address is turned OFF. • If a 32-bit device is specified, only the bottom 16 bits are used. 			
		Time out		Specify the queuing time for when the FTP server does not respond to an access request. The value can be from 10 to 120 seconds.			
Record Status Address			<p>Specify the address for the event recorder function. Use a sequence of two Words from the specified address.</p> <table border="1" style="margin-left: auto; margin-right: auto;"> <tr> <td>+0</td> <td>Control</td> </tr> <tr> <td>+1</td> <td>Save Monitor Status</td> </tr> </table> <ul style="list-style-type: none"> • Control After a save error occurs, turn ON bit 1 to restore the error and enable the save operation. 	+0	Control	+1	Save Monitor Status
+0	Control						
+1	Save Monitor Status						

Continued

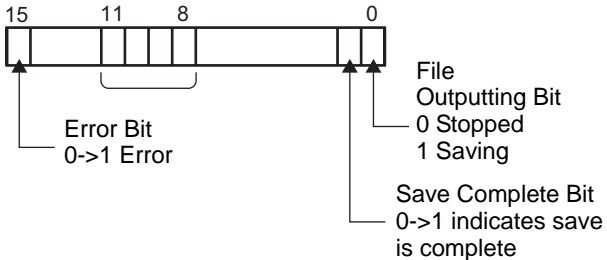
Setting	Description																																				
Record Status Address	<ul style="list-style-type: none"> Save Monitor Status The event recorder save status and error status are saved.  <p>The error status indicates the following conditions. (Error Code)</p> <table border="1" data-bbox="417 672 1174 1387"> <thead> <tr> <th>Error Code</th> <th>Condition</th> <th>Description</th> </tr> </thead> <tbody> <tr> <td>0</td> <td>Completed Successfully</td> <td>–</td> </tr> <tr> <td>1 to 3</td> <td>Reserved</td> <td>–</td> </tr> <tr> <td>4</td> <td>No CF Card</td> <td>The CF Card is not inserted in the GP, or the CF Card cover is not closed.</td> </tr> <tr> <td>5</td> <td>CF Write Error</td> <td>Writing to the CF Card failed or there is not enough free space.</td> </tr> <tr> <td>6</td> <td>Reserved</td> <td>–</td> </tr> <tr> <td>7</td> <td>CF Card Error</td> <td>CF Card is invalid or unformatted, or the media inserted is not a CF Card.</td> </tr> <tr> <td>8</td> <td>Reserved</td> <td>–</td> </tr> <tr> <td>9</td> <td>FTP Connection Error</td> <td>The FTP server is not operating normally, or the FTP server does not exist.</td> </tr> <tr> <td>10</td> <td>FTP Login Error</td> <td>The FTP user name or password is incorrect.</td> </tr> <tr> <td>11</td> <td>Write Error</td> <td>The logged in user does not have writing privileges, or writing to the FTP server has failed, or there is not enough free space.</td> </tr> <tr> <td>12 to 15</td> <td>Reserved</td> <td>–</td> </tr> </tbody> </table> <p>NOTE</p> <ul style="list-style-type: none"> If a 32-bit device is specified, only the bottom 16 bits are used. 	Error Code	Condition	Description	0	Completed Successfully	–	1 to 3	Reserved	–	4	No CF Card	The CF Card is not inserted in the GP, or the CF Card cover is not closed.	5	CF Write Error	Writing to the CF Card failed or there is not enough free space.	6	Reserved	–	7	CF Card Error	CF Card is invalid or unformatted, or the media inserted is not a CF Card.	8	Reserved	–	9	FTP Connection Error	The FTP server is not operating normally, or the FTP server does not exist.	10	FTP Login Error	The FTP user name or password is incorrect.	11	Write Error	The logged in user does not have writing privileges, or writing to the FTP server has failed, or there is not enough free space.	12 to 15	Reserved	–
	Error Code	Condition	Description																																		
0	Completed Successfully	–																																			
1 to 3	Reserved	–																																			
4	No CF Card	The CF Card is not inserted in the GP, or the CF Card cover is not closed.																																			
5	CF Write Error	Writing to the CF Card failed or there is not enough free space.																																			
6	Reserved	–																																			
7	CF Card Error	CF Card is invalid or unformatted, or the media inserted is not a CF Card.																																			
8	Reserved	–																																			
9	FTP Connection Error	The FTP server is not operating normally, or the FTP server does not exist.																																			
10	FTP Login Error	The FTP user name or password is incorrect.																																			
11	Write Error	The logged in user does not have writing privileges, or writing to the FTP server has failed, or there is not enough free space.																																			
12 to 15	Reserved	–																																			

◆ Event Recorder Timing Chart

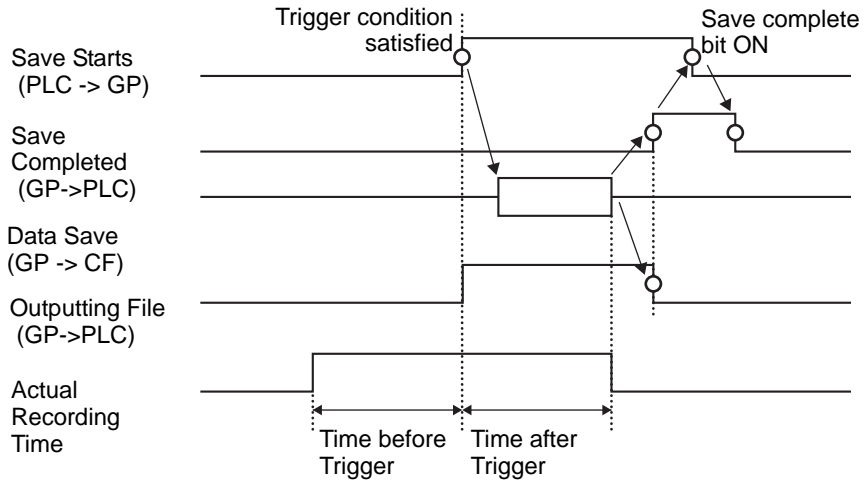

27.9.2 [FTP Server] Settings Guide

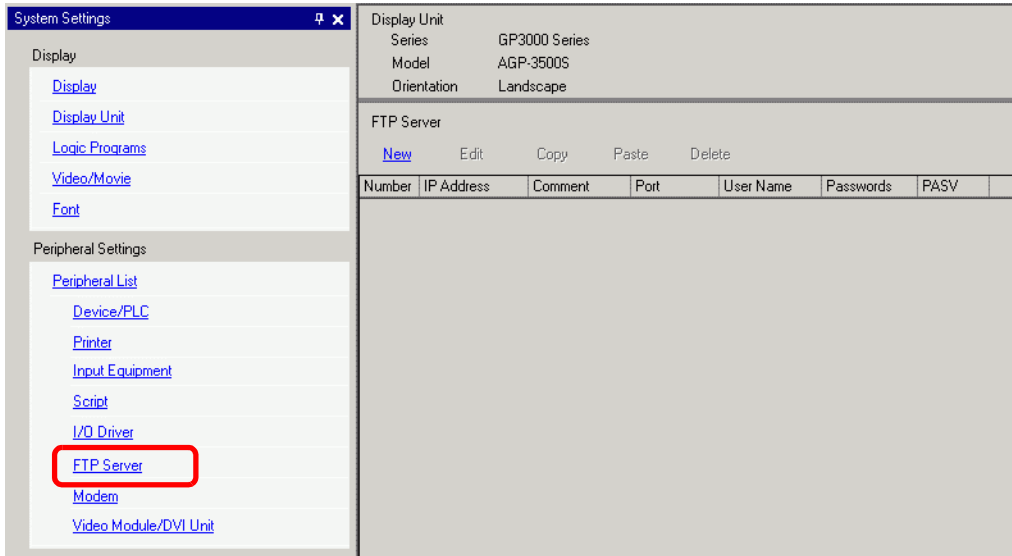

Setting	Description
Create	Display the [FTP Server] dialog box.
Edit	Edit the registered contents.
Copy	Copy the registered contents from the selected row.
Paste	Paste the copied registered contents to the selected row in the list.
Delete	Delete the selected row.

◆ FTP Server Registration

Setting		Description
Number		Specify the registry Number
IP Address		Specify the IP address to register for the FTP server.
Comment		Type any comments. You can use up to 12 single-byte alphanumeric characters for the password.
Port		Specify the FTP server port Number
PASV		Specify whether to use PASV mode. This option is typically used when the connection is blocked by network security.
User Name		Defines the login user name for the FTP server. You can use up to 16 single-byte alphanumeric characters for the password.
Password	Password	Defines the password for the FTP server. You can use up to 16 single-byte alphanumeric characters for the password.
	Confirm	Re-enter the password for confirmation.

27.9.3 Common [Movie] Settings Guide

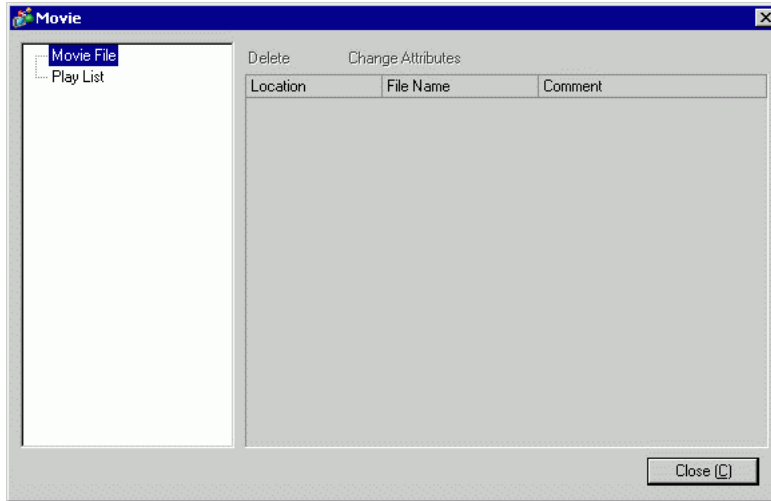

Setting	Description
Movie File	Display a list of movie files saved in the MOVIE folder in the specified "Destination Folder".
Delete	Delete the selected file from the list.
Change Attribute	Change the file name or file comment selected from the list.
Play List	Display the existing playlist files.
Create	Create a new playlist file.
Delete	Delete the selected playlist file from the list.
Change Attribute	Change the file name of a playlist file selected from the list.

Continued

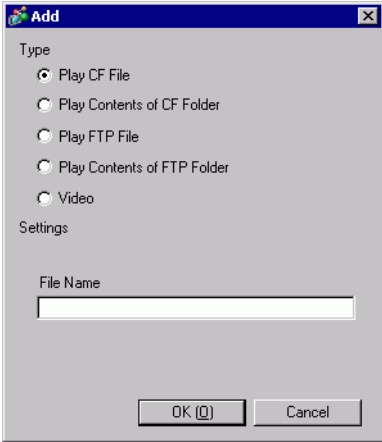
Setting		Description	
(File Name)		Display the contents of the created playlist file.	
Add		<p>Specify a movie file or folder to add to the playlist. When the folder is specified, movie files within the folder are played in the order in which the files were created on the CF card or the FTP server.</p> 	
	Type	Play CF File	Add the file saved in the MOVIE folder in CF to the playlist. When entering "\\MC" into "File Name", "\\MOVIE" and "\\" are combined and become "\\MOVIE\MC\".
		Play Contents of CF Folder	When "\\MC" is entered at [Folder Name], "\\MOVIE" is added to display "\\MOVIE\MC". When entering "\\MC" in the "File Name", "\\MOVIE" is combined and it becomes "\\MOVIE\MC\".
		Play FTP File	Adds a file on the FTP server to the playlist. Select the registry Number of FTP server where the file is saved, and input the file name.
		Play Contents of FTP Folder	Adds a folder on the FTP server to the playlist. Select the registry Number of the FTP server where the folder is saved, and input the folder name.
		Video	Add real-time images to the playlist.
	Settings	File Name/ Folder Name	Input a file name or folder name.
	Edit		Edit the settings for a file or folder selected on the list.
	Copy		Copy a file or folder selected from the list.
	Paste		Paste the copied file or folder to the list.
Delete		Delete the selected row from the list.	

27.9.4 [Movie Player] Settings Guide

This is a component used for playing movies. Use it for displaying images from video cameras and for playing movie files. You can place only one player on a screen.

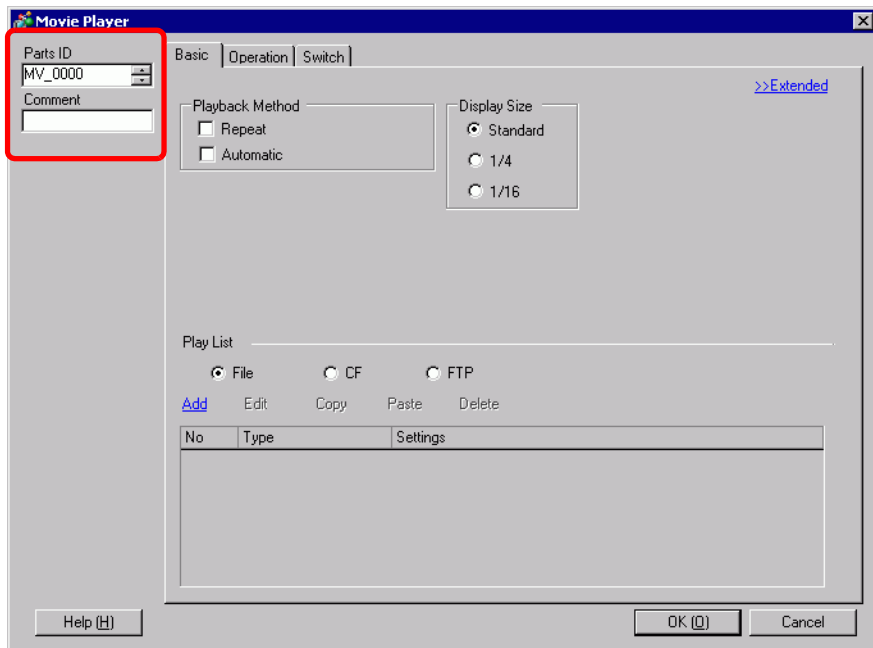

Setting	Description
Part ID	Placed parts are assigned an ID number. Part ID of Movie Player: MV_**** (four digit number) The letter portion is fixed. You can change the number portion within the range of 0000-9999.
Comment	The comment for each Part can be up to 20 characters.

■ Basic Settings/Basic

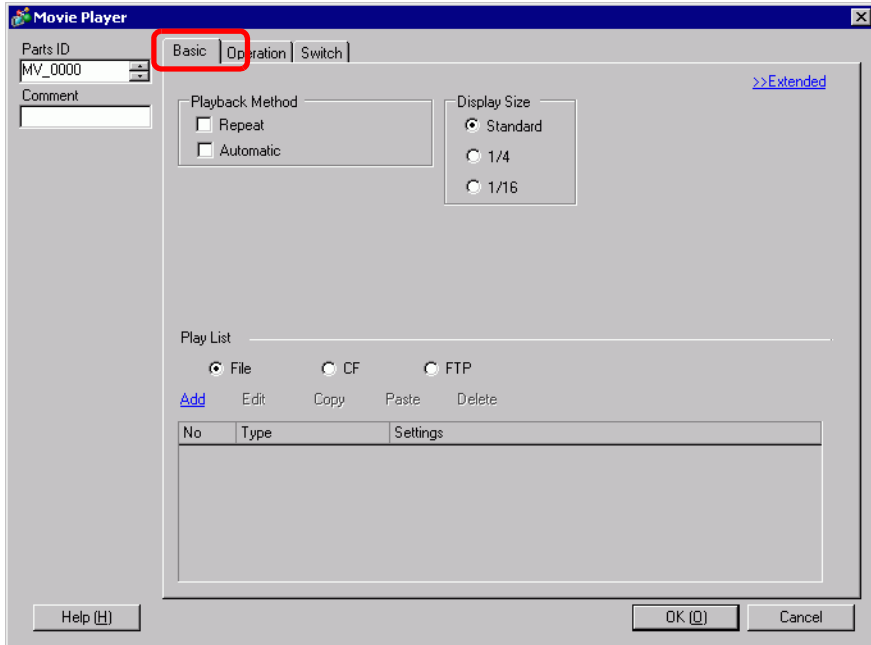

Setting	Description
Playback Method	Select the play method.
Loop	Repeat the movie. Repeatedly plays movies in the order in the playlist until stopped.
Automatic	Play a movie immediately after the screen is switched to a screen with a movie player.
Display size	Select the image display size. Once selected, the actual display size depends on the type of image input signal.
Standard	<ul style="list-style-type: none"> • For NTSC: 640 x 480 pixels • For PAL: 768 x 576 pixels • For SECAM: 768 x 576 pixels
1/4	<ul style="list-style-type: none"> • For NTSC: 320 x 240 pixels • For PAL: 384 x 288 pixels • For SECAM: 384 x 288 pixels
1/16	<ul style="list-style-type: none"> • For NTSC: 160 x 120 pixels • For PAL: 192 x 144 pixels • For SECAM: 192 x 144 pixels

Continued

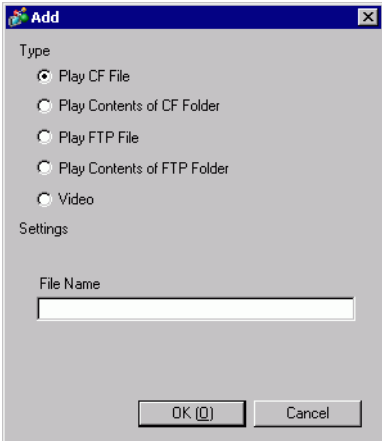
Setting		Description
Play List		Specify the movie file to be played.
File		Specify a file and folder to play directly from the movie player.
Add		<p>Specify a movie file (or folder) to add to the list. When the folder is specified, movie files within the folder are played in the order in which the files were created on the CF card or the FTP server.</p> 
Type	Play CF File	Add the files saved in the MOVIE folder in the CF card to the playlist. When entering "\MC" into "File Name", "\MOVIE" and "\" are combined and become "\MOVIE\MC\".
	Play Contents of CF Folder	When "\MC" is entered at [Folder Name], "\MOVIE" is added to display "\MOVIE\MC". When entering "\MC" in the "File Name", "\MOVIE" is combined and it becomes "\MOVIE\MC\".
	Play FTP File	Add a file saved on FTP server. Select the registry Number of FTP server where the file is saved, and input the file name.
	Play Contents of FTP Folder	Add a folder saved on the FTP server. Select the registry Number of the FTP server where the folder is saved, and input the folder name.
	Video	Add real-time images to the playlist.
Settings	File Name/ Folder Name	Input a file name or folder name.
CF		Specify the playlist file (.txt) created in [Movie] in the common settings. The file is saved in the MOVIE folder on the CF Card.
FTP		Specify the playlist file on the FTP server.
FTP Server		Select the FTP server registry Number
List File Name		Input the file name of the playlist on the specified FTP server. Use the FTP server route for input. (For example, "*/*/*.txt")
Time out		Set the wait time for when the FTP server does not respond to an access request.

■ Basic Settings/Details

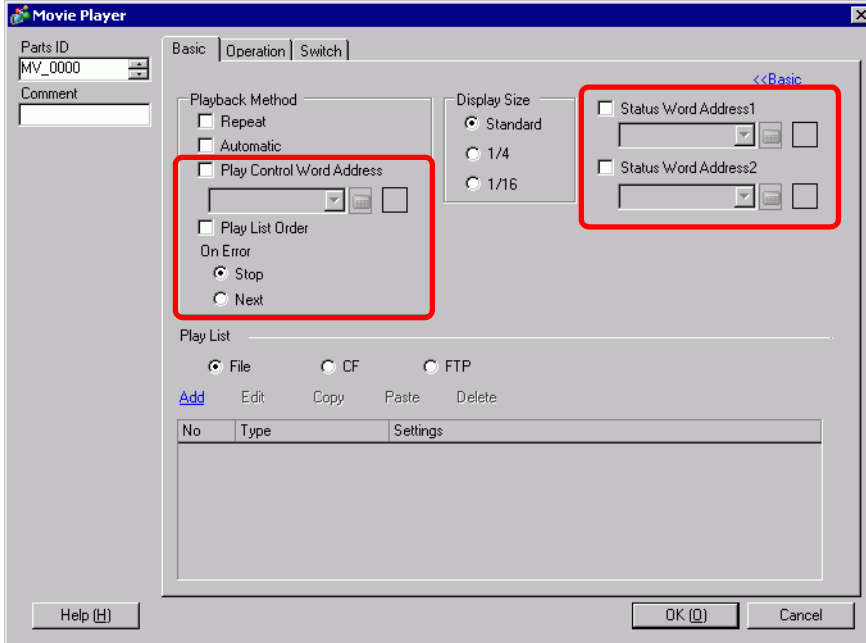

Setting	Description										
<p>Play Control Word Address</p>	<p>Control the player from the connection device. Use a sequence of 5 Words from the specified address.</p> <p style="text-align: center;">Play Control Word Address</p> <table border="1" style="margin-left: auto; margin-right: auto;"> <tr> <td>+0</td> <td>Control</td> </tr> <tr> <td>+1</td> <td>Play Mode</td> </tr> <tr> <td>+2</td> <td>Index Number</td> </tr> <tr> <td>+3</td> <td>Option</td> </tr> <tr> <td>+4</td> <td>Status</td> </tr> </table> <p>Refer to the following for how to operate.</p> <ul style="list-style-type: none"> ☞ " ◆ Operation Procedure for Play Control Address" (page 27-107) ☞ " ◆ Timing Chart for Play Control" (page 27-107) 	+0	Control	+1	Play Mode	+2	Index Number	+3	Option	+4	Status
+0	Control										
+1	Play Mode										
+2	Index Number										
+3	Option										
+4	Status										

Continued

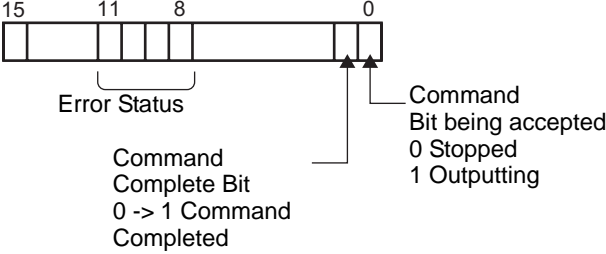
Setting	Description										
Playback Method Play Control Word Address	<ul style="list-style-type: none"> Status  <p>(Error Code)</p> <table border="1" data-bbox="482 537 1090 736"> <tr> <td>0</td> <td>Completed Successfully</td> </tr> <tr> <td>1</td> <td>The specified value for the play method is not within the setting range</td> </tr> <tr> <td>2</td> <td>Executing an instruction from the switch</td> </tr> <tr> <td>3</td> <td>Saving a movie</td> </tr> <tr> <td>4 to 15</td> <td>Reserved</td> </tr> </table>	0	Completed Successfully	1	The specified value for the play method is not within the setting range	2	Executing an instruction from the switch	3	Saving a movie	4 to 15	Reserved
0	Completed Successfully										
1	The specified value for the play method is not within the setting range										
2	Executing an instruction from the switch										
3	Saving a movie										
4 to 15	Reserved										
Reserved	Play List Order Specifies whether or not to play movies in a specified order. When the player reaches the end of the playlist, files will play as follows, depending on whether [Loop] is selected. [Repeat] selected: Plays movies from the top of the list. [Repeat] not selected: Stops playing movies.										
On Error	Specifies how to handle the following types of errors when a movie file cannot play. <ul style="list-style-type: none"> The CF Card is not inserted when CF play is selected Unable to connect to FTP server when FTP play is selected No file is found for CF play and FTP play Cannot open the file for CF play and FTP play The specified file is not in a format compatible for CF play or FTP play <table border="1" data-bbox="196 1174 1090 1290"> <tr> <td>Stop</td> <td>Stops the operation if the movie cannot be played.</td> </tr> <tr> <td>Next</td> <td>If a movie cannot be played, plays the next movie file. In this case, no error status is stored in [Status Word Address 1].</td> </tr> </table>	Stop	Stops the operation if the movie cannot be played.	Next	If a movie cannot be played, plays the next movie file. In this case, no error status is stored in [Status Word Address 1].						
Stop	Stops the operation if the movie cannot be played.										
Next	If a movie cannot be played, plays the next movie file. In this case, no error status is stored in [Status Word Address 1].										
Status Word Address 1	If you want to check the error information, play size, or information on the play position, specify a Word Address for storing the information. Use four Words from the specified address. For a 32-bit device, use the lower 16 bits only. <p style="text-align: center;">Status Word Address 1</p> <table border="1" data-bbox="596 1491 858 1640"> <tr> <td>+0</td> <td>Error Status</td> </tr> <tr> <td>+1</td> <td>Play Size</td> </tr> <tr> <td>+2</td> <td>Play Position X</td> </tr> <tr> <td>+3</td> <td>Play Position Y</td> </tr> </table>	+0	Error Status	+1	Play Size	+2	Play Position X	+3	Play Position Y		
+0	Error Status										
+1	Play Size										
+2	Play Position X										
+3	Play Position Y										

Continued

Setting	Description																																												
Status Word Address 1	<ul style="list-style-type: none"> Error Status <div style="text-align: center;"> </div> <p> Error Bit 0 No error 1 Error </p> <p>The error bit is ON when an attempt to play a movie failed (for example, because a file does not exist or a connection cannot be established to the FTP server), or when a status error occurs in Movie Player (for example, a because file is corrupted during play).</p> <table border="1" style="width: 100%; border-collapse: collapse;"> <thead> <tr> <th style="text-align: center;">State of the error detail bit</th> <th style="text-align: center;">Error Name</th> <th style="text-align: center;">Description</th> </tr> </thead> <tbody> <tr> <td style="text-align: center;">0</td> <td>Completed Successfully</td> <td>Operating normally.</td> </tr> <tr> <td style="text-align: center;">1 to 3, 6, 8, 12 to 15, 17 to 127</td> <td>Reserved</td> <td>These are reserved numbers and are not specified.</td> </tr> <tr> <td style="text-align: center;">4</td> <td>No CF Card</td> <td>The CF Card is not inserted. The hatch is open.</td> </tr> <tr> <td style="text-align: center;">5</td> <td>CF Read Error</td> <td>An attempt to read from the CF Card failed.</td> </tr> <tr> <td style="text-align: center;">7</td> <td>CF Card Error</td> <td>The CF Card is defective. This is not a CF Card.</td> </tr> <tr> <td style="text-align: center;">9</td> <td>FTP server connection error</td> <td>The FTP server cannot be accessed.</td> </tr> <tr> <td style="text-align: center;">10</td> <td>FTP Login Error</td> <td>An attempt to log in to the FTP server has failed.</td> </tr> <tr> <td style="text-align: center;">11</td> <td>Write error</td> <td>An attempt to write data to the FTP server failed.</td> </tr> <tr> <td style="text-align: center;">16</td> <td>The file is corrupt.</td> <td>The specified file is not in SDX format.</td> </tr> </tbody> </table> Display size The current display size is stored. <ul style="list-style-type: none"> 0 Normal mode 1 1/4 mode 2 1/16 mode 3 Reserved for this and above (normal type) Play X/Y Coordinates The following table lists the coordinate ranges in which the movie plays according to the display size and the image input signal settings. <table border="1" style="width: 100%; border-collapse: collapse; margin-top: 10px;"> <thead> <tr> <th rowspan="2" style="text-align: center;">Display size</th> <th colspan="2" style="text-align: center;">Image Input Signal Settings</th> </tr> <tr> <th style="text-align: center;">NTSC</th> <th style="text-align: center;">PAL/SECAM</th> </tr> </thead> <tbody> <tr> <td style="text-align: center;">Standard</td> <td style="text-align: center;">(0,0) to (639,479)</td> <td style="text-align: center;">(0,0) to (767,575)</td> </tr> <tr> <td style="text-align: center;">1/4</td> <td style="text-align: center;">(0,0) to (319,239)</td> <td style="text-align: center;">(0,0) to (383,287)</td> </tr> <tr> <td style="text-align: center;">1/16</td> <td style="text-align: center;">(0,0) to (159,119)</td> <td style="text-align: center;">(0,0) to (191,143)</td> </tr> </tbody> </table> 	State of the error detail bit	Error Name	Description	0	Completed Successfully	Operating normally.	1 to 3, 6, 8, 12 to 15, 17 to 127	Reserved	These are reserved numbers and are not specified.	4	No CF Card	The CF Card is not inserted. The hatch is open.	5	CF Read Error	An attempt to read from the CF Card failed.	7	CF Card Error	The CF Card is defective. This is not a CF Card.	9	FTP server connection error	The FTP server cannot be accessed.	10	FTP Login Error	An attempt to log in to the FTP server has failed.	11	Write error	An attempt to write data to the FTP server failed.	16	The file is corrupt.	The specified file is not in SDX format.	Display size	Image Input Signal Settings		NTSC	PAL/SECAM	Standard	(0,0) to (639,479)	(0,0) to (767,575)	1/4	(0,0) to (319,239)	(0,0) to (383,287)	1/16	(0,0) to (159,119)	(0,0) to (191,143)
State of the error detail bit	Error Name	Description																																											
0	Completed Successfully	Operating normally.																																											
1 to 3, 6, 8, 12 to 15, 17 to 127	Reserved	These are reserved numbers and are not specified.																																											
4	No CF Card	The CF Card is not inserted. The hatch is open.																																											
5	CF Read Error	An attempt to read from the CF Card failed.																																											
7	CF Card Error	The CF Card is defective. This is not a CF Card.																																											
9	FTP server connection error	The FTP server cannot be accessed.																																											
10	FTP Login Error	An attempt to log in to the FTP server has failed.																																											
11	Write error	An attempt to write data to the FTP server failed.																																											
16	The file is corrupt.	The specified file is not in SDX format.																																											
Display size	Image Input Signal Settings																																												
	NTSC	PAL/SECAM																																											
Standard	(0,0) to (639,479)	(0,0) to (767,575)																																											
1/4	(0,0) to (319,239)	(0,0) to (383,287)																																											
1/16	(0,0) to (159,119)	(0,0) to (191,143)																																											

Continued

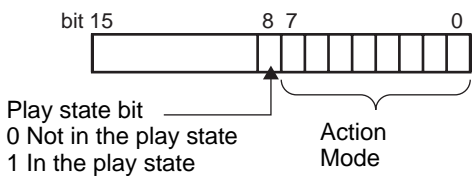
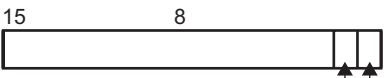
Setting	Description				
<p>Status Word Address 2</p>	<p>Set to use the address for watching the movie playback state. Use 2 sequential words from the specified address. For a 32-bit device, use the lower 16 bits only.</p> <p style="text-align: center;">Status Word Address 2</p> <table border="1" style="margin-left: auto; margin-right: auto;"> <tr> <td style="padding: 2px;">+0</td> <td style="padding: 2px;">Play Monitor</td> </tr> <tr> <td style="padding: 2px;">+1</td> <td style="padding: 2px;">Slow Update Rate</td> </tr> </table> <ul style="list-style-type: none"> • Play Monitor <div style="margin-left: 20px;">  <p style="margin-left: 40px;">bit 15 8 7 0</p> <p style="margin-left: 40px;">Play state bit Action Mode</p> <p style="margin-left: 40px;">0 Not in the play state 1 In the play state (excluding stop state).</p> </div> • The operation mode for the Play Monitor is stored in the bottom eight bits. • The play state bit indicates that the Play Monitor is actually in the play state. There are no repeat specifications, and even when the play switch is ON, if play is completed to the end, the state changes to state other than play state. • The following lists the numbers to be specified for the Play Monitor operation mode. <ul style="list-style-type: none"> 0 Stop 1 Play 2 Pause 3 Fast Forward 4 Rewind 5 Slow Motion 00xFF Video Display <p style="margin-left: 40px;">Numbers other than those above are reserved.</p> • Slow Update Rate <p style="margin-left: 20px;">When running in slow motion, stores the play speed.</p> <div style="margin-left: 40px;">  <p style="margin-left: 40px;">15 8</p> <p style="margin-left: 40px;">Slow motion status bit</p> <p style="margin-left: 40px;">00 1/2 01 1/4 10 1/8</p> </div> 	+0	Play Monitor	+1	Slow Update Rate
+0	Play Monitor				
+1	Slow Update Rate				

◆ **Operation Procedure for Play Control Address**

Normal Play

- 1 In the [Index Number] address, store the index number of the movie file you want to play.
- 2 In the [Play Mode] address store the value 8, and in the [Control] address turn on the command send bit (bit 0). The index number is set. (The movie being played will be stopped)
- 3 Turns back the command send bit to off.
- 4 In the [Play Mode] address store the value 1, and turn on the command send bit. This will play the movie with the defined index number.

Play in Forced Play Mode

Regardless of the current movie play status, forcibly plays the movie with the specified index number.

- 1 In the [Index Number] address, store the index number of the movie file you want to play.
- 2 In the [Control] address, turn ON the forced play bit (bit 8). Play will begin.

NOTE

- While the forced play bit is on, the command send bit will not turn on.
- If the play notification bit (bit 9) is toggled while the forced play bit is on, plays the movie with the current index number.
- In forced play mode, to stop the movie from playing you need to turn off the forced play bit. If neither [Loop] nor [Play List Order] is selected, movie playback stops at the end of the movie. If [Loop] is cleared and [Play List Order] is selected, movie playback stops at the end of the movie playlist.

◆ **Timing Chart for Play Control**

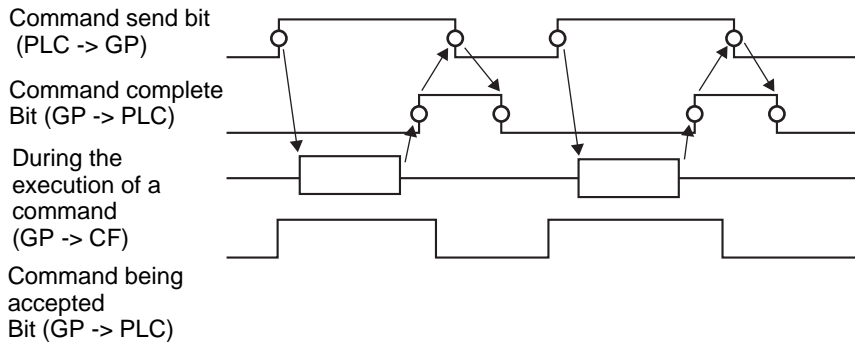

■ Operation

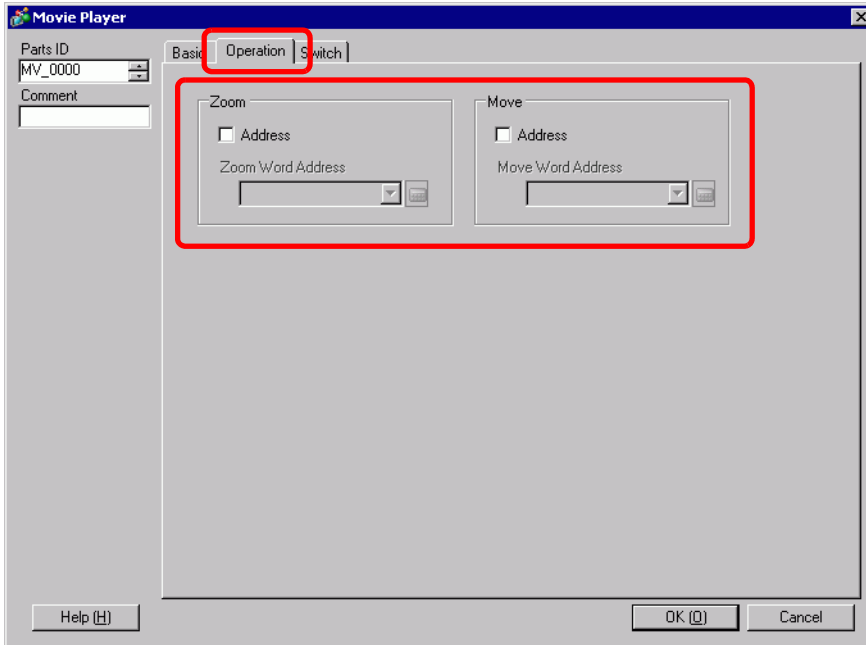

Setting	Description									
Zoom	Zoom display settings									
Address	Specify whether to use zoom display or not.									
Zoom Word Address	<p>Specify an address for zoom operations. Use a sequence of 3 Words from the specified address. For a 32-bit device, use only the bottom 16 bits.</p> <table border="1"> <tr> <td>+0</td> <td>Control</td> <td>Control the zoom function.</td> </tr> <tr> <td>+1</td> <td>Zoom specifications</td> <td>Specify the zoom size.</td> </tr> <tr> <td>+2</td> <td>Status</td> <td>Display the error state, etc.</td> </tr> </table> <p>☞ " ◆ Timing Chart for Zoom Operation of the Movie Player" (page 27-111)</p> <ul style="list-style-type: none"> Control <p>Zoom set bit 0 Normal 1 Zoom</p>	+0	Control	Control the zoom function.	+1	Zoom specifications	Specify the zoom size.	+2	Status	Display the error state, etc.
+0	Control	Control the zoom function.								
+1	Zoom specifications	Specify the zoom size.								
+2	Status	Display the error state, etc.								

Continued

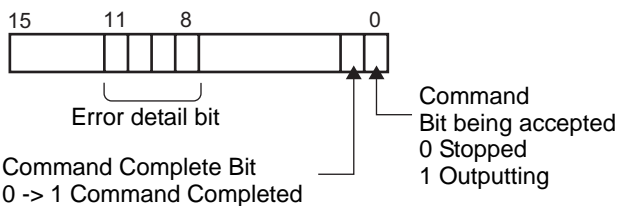
Setting	Description															
Zoom Zoom Word Address	<ul style="list-style-type: none"> • Zoom specifications Specify the zoom by storing one of the following values: <ul style="list-style-type: none"> 0 Normal 1 1/4 2 1/16 3 0xFFFE Reserved (does not change) 0xFFFF Normal (return to settings on the main screen) • Status <div style="text-align: center;">  <p>Command Complete Bit 0 -> 1 Command Completed</p> <p>Command Bit being accepted 0 Stopped 1 Outputting</p> </div> <table border="1" style="width: 100%; border-collapse: collapse;"> <thead> <tr> <th style="width: 15%;">State of the error detail bit</th> <th style="width: 35%;">Error Name</th> <th style="width: 50%;">Description</th> </tr> </thead> <tbody> <tr> <td style="text-align: center;">0</td> <td>Completed Successfully</td> <td>Operating normally.</td> </tr> <tr> <td style="text-align: center;">1</td> <td>The zoom specification is invalid.</td> <td>The specified value is out of the acceptable range.</td> </tr> <tr> <td style="text-align: center;">2</td> <td>Executing an instruction from the switch</td> <td>Processing a switch instruction set up on the screen. The request cannot be processed.</td> </tr> <tr> <td style="text-align: center;">3 to 15</td> <td>Reserved</td> <td>These are reserved numbers and are not specified.</td> </tr> </tbody> </table> <p>☞ " ◆ Screen Display When Zoom is Specified" (page 27-111)</p>	State of the error detail bit	Error Name	Description	0	Completed Successfully	Operating normally.	1	The zoom specification is invalid.	The specified value is out of the acceptable range.	2	Executing an instruction from the switch	Processing a switch instruction set up on the screen. The request cannot be processed.	3 to 15	Reserved	These are reserved numbers and are not specified.
State of the error detail bit	Error Name	Description														
0	Completed Successfully	Operating normally.														
1	The zoom specification is invalid.	The specified value is out of the acceptable range.														
2	Executing an instruction from the switch	Processing a switch instruction set up on the screen. The request cannot be processed.														
3 to 15	Reserved	These are reserved numbers and are not specified.														
Move	Settings for moving the screen position.															
Address	If a movie to be played does not fit completely on the screen, specify whether to move the movie play coordinates.															
Move Word Address	Specify an address for moving the play position. Use a sequence of 2 Words from the specified address. For a 32-bit device, use only the bottom 16 bits.															

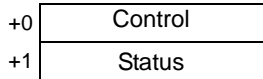

☞ " ◆ Timing Chart for Move Operation of Movie Player" (page 27-113)

Continued

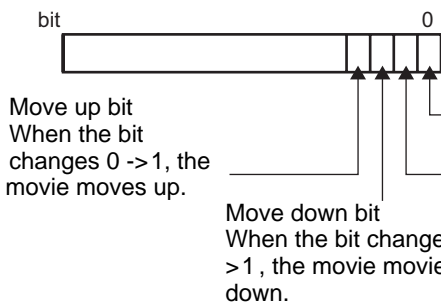
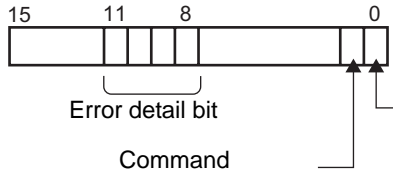
Setting	Description														
Move	Move Word Address	<ul style="list-style-type: none"> Control <div style="display: flex; align-items: center; margin-top: 10px;">  <div style="margin-left: 20px;"> <p>Move up bit When the bit changes 0 -> 1, the movie moves up.</p> <p>Move down bit When the bit changes 0 -> 1, the movie moves down.</p> <p>Move right bit When the bit changes 0 -> 1, the movie moves to the right.</p> <p>Move left bit When the bit changes 0 -> 1, the movie moves to the left.</p> </div> </div> <p>The bit priority is higher for the upper bits and lower for the lower bits. When each allocated bit is turned ON, the movie moves according to the following dots.</p> <p>If a movie cannot be moved, an error is returned to the status address.</p> 													
		<table border="1" style="width: 100%; border-collapse: collapse;"> <thead> <tr> <th style="width: 20%;">Direction</th> <th style="width: 40%;">When playing a movie</th> <th style="width: 40%;">When playing a video</th> </tr> </thead> <tbody> <tr> <td>Landscape direction</td> <td>2 dot unit</td> <td>2 dot unit</td> </tr> <tr> <td>Portrait direction</td> <td>Normal size 2 dot unit 1/4 and 1/16 sizes 1 dot unit</td> <td>1 dot unit</td> </tr> </tbody> </table>	Direction	When playing a movie	When playing a video	Landscape direction	2 dot unit	2 dot unit	Portrait direction	Normal size 2 dot unit 1/4 and 1/16 sizes 1 dot unit	1 dot unit				
Direction	When playing a movie	When playing a video													
Landscape direction	2 dot unit	2 dot unit													
Portrait direction	Normal size 2 dot unit 1/4 and 1/16 sizes 1 dot unit	1 dot unit													
Move	Move Word Address	<ul style="list-style-type: none"> Status <div style="display: flex; align-items: center; margin-top: 10px;">  <div style="margin-left: 20px;"> <p>Command Complete Bit 0 -> 1 Command</p> <p>Command Bit being accepted 0 Stopped 1 Outputting</p> </div> </div> 													
		<table border="1" style="width: 100%; border-collapse: collapse;"> <thead> <tr> <th style="width: 15%;">State of the error detail bit</th> <th style="width: 35%;">Error Name</th> <th style="width: 50%;">Description</th> </tr> </thead> <tbody> <tr> <td style="text-align: center;">0</td> <td>Completed Successfully</td> <td>Operating normally.</td> </tr> <tr> <td style="text-align: center;">1</td> <td>The movie is at the screen edge.</td> <td>The movie cannot be moved because it is at the edge of the screen.</td> </tr> <tr> <td style="text-align: center;">2</td> <td>Executing an instruction from the switch</td> <td>Processing a switch instruction set up on the screen. The request cannot be processed.</td> </tr> <tr> <td style="text-align: center;">3 to 15</td> <td>Reserved</td> <td>These are reserved numbers and are not specified.</td> </tr> </tbody> </table>	State of the error detail bit	Error Name	Description	0	Completed Successfully	Operating normally.	1	The movie is at the screen edge.	The movie cannot be moved because it is at the edge of the screen.	2	Executing an instruction from the switch	Processing a switch instruction set up on the screen. The request cannot be processed.	3 to 15
State of the error detail bit	Error Name	Description													
0	Completed Successfully	Operating normally.													
1	The movie is at the screen edge.	The movie cannot be moved because it is at the edge of the screen.													
2	Executing an instruction from the switch	Processing a switch instruction set up on the screen. The request cannot be processed.													
3 to 15	Reserved	These are reserved numbers and are not specified.													

◆ **Timing Chart for Zoom Operation of the Movie Player**

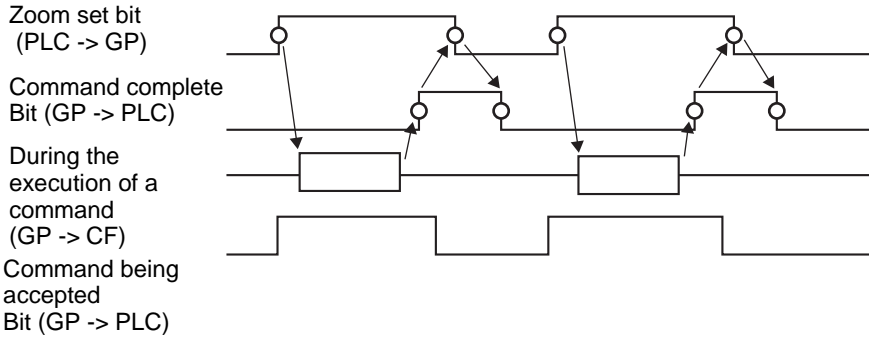

◆ **Screen Display When Zoom is Specified**

- When the Display Size is [1/4] and Screen Size is 1/4 of the movie image

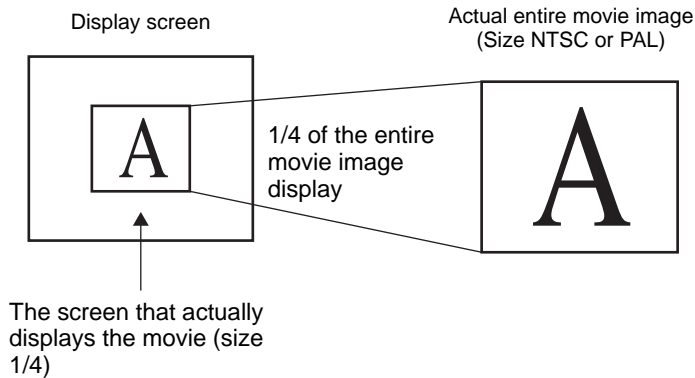

- When the display size is [Normal] and the screen size is 1/4 of the movie image

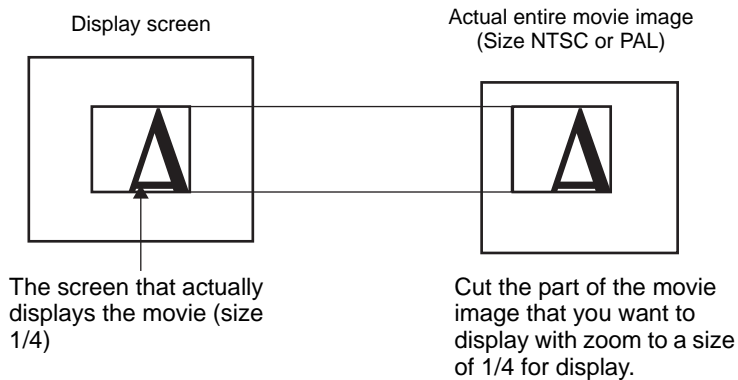

- When the display size is [1/16] and the screen size is 1/16 of the movie image

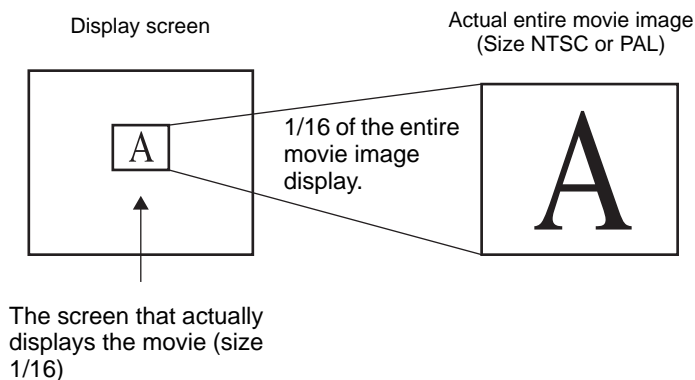

- When the display size is [1/4] and the screen size is 1/16 of the movie image

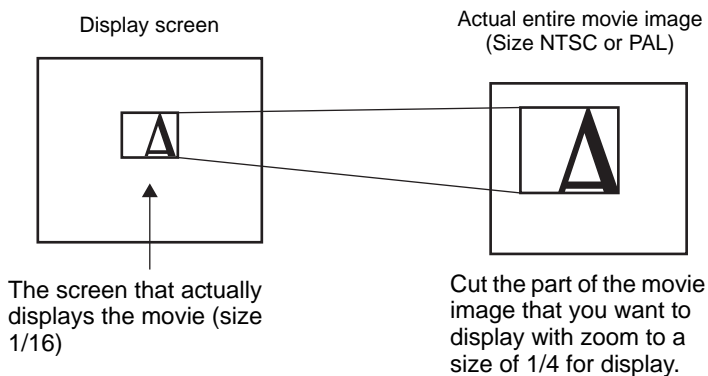

- When the display size is [Normal] and the screen size is 1/16 of the movie image

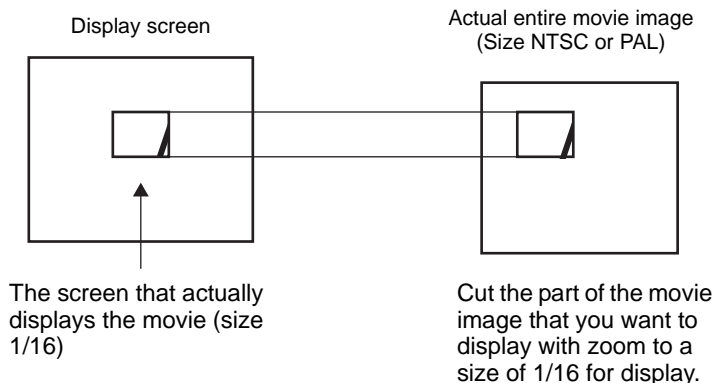

- If a movie image is zoomed and the size is smaller than the display size, the display size automatically changes to the movie image size.

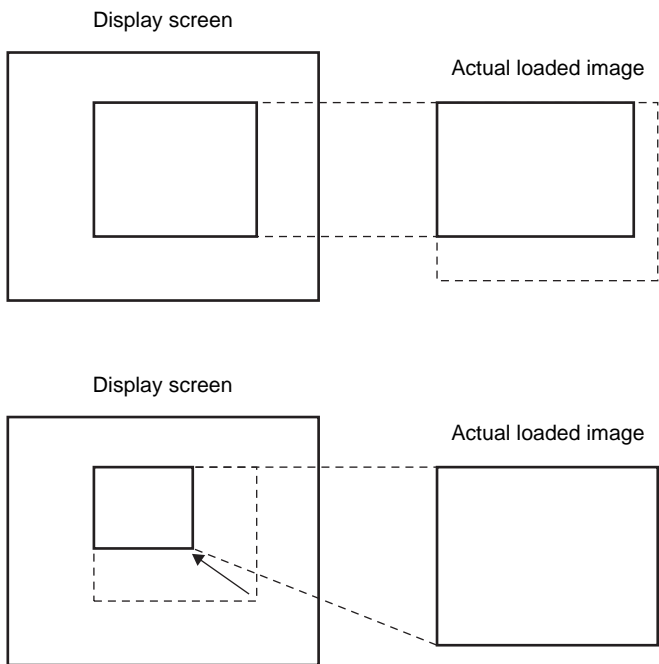

◆ **Timing Chart for Move Operation of Movie Player**

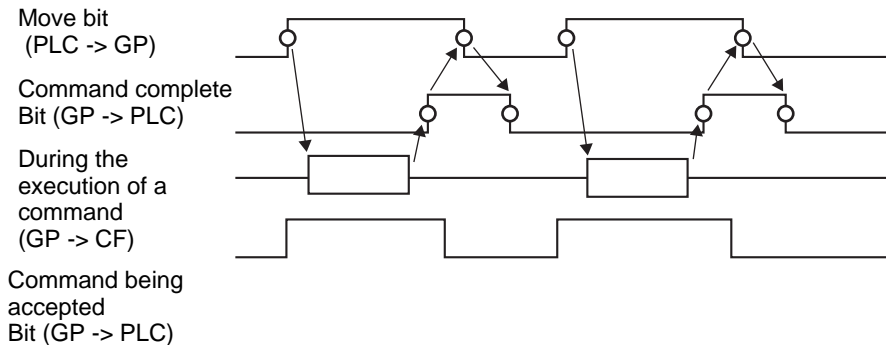

■ Switch

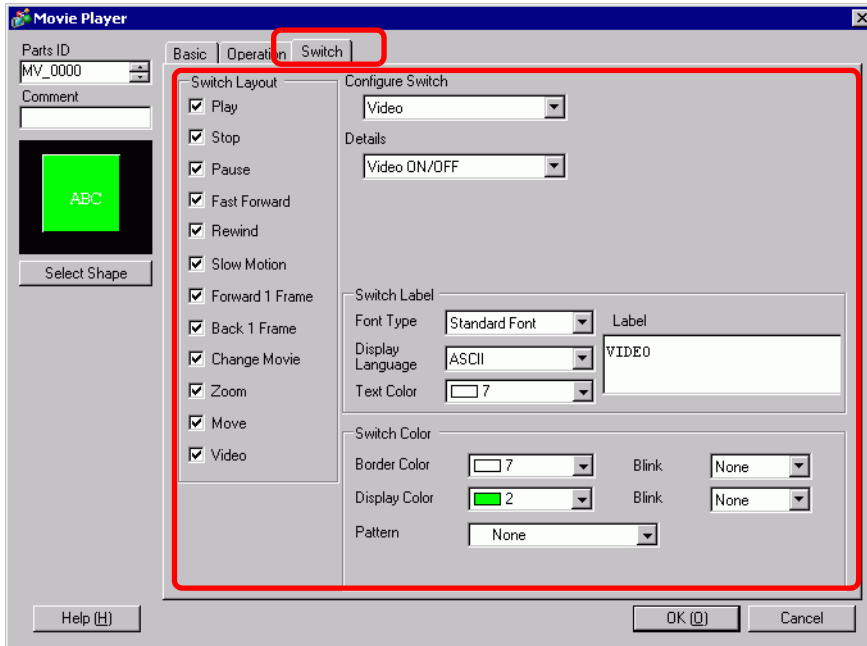

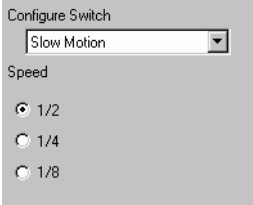

Setting	Description
Select Shape	Open the Select Shape dialog box to choose the Part shape. NOTE • Depending on the shape, you may not be able to change the color.

Continued

Setting	Description
Switch Layout	<p>Select the operation switch to be attached to Movie Player.</p> <ul style="list-style-type: none"> • Play Starts play. • Stop Stops playback. The movie file will play from the beginning when played again. It cannot be played from the point where it was stopped. • Pause Pauses play. • Fast Forward Plays a movie in fast forward. This switch operates even in the stop state. • Rewind Plays a movie while rewinding. This switch does not operate in the stopped state. • Slow Motion Plays a movie in slow motion. This switch operates even in the stop state. • Forward 1 Frame Forwards a movie frame by frame. This switch can be used only in the pause state. • Back 1 Frame Reverses a movie frame by frame. This switch can be used only in the pause state. • Change Movie Stop the movie being played and play another movie. To specify a movie to be played, select "Next", "Previous" or "Specify number". • Zoom Enlarges/reduces the movie display. • Move Moves the movie display position. • Video Switch the video camera picture being displayed.
Select Switch	From among the switches on the screen, select a switch for specifying the details and labels.
Speed	<p>This item is displayed only when [Slow Motion] is selected in [Configure Switch]. Select the speed for slow motion from [1/2], [1/4] or [1/8].</p> 

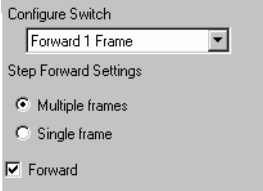
Continued

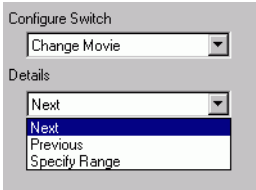
Setting	Description
Step Forward Settings	<p>This item is displayed only when [Forward 1 Frame] is selected in [Configure Switch]. Select the frame width.</p> <p>Multiple Frames Forward a movie by "I" frames. Single Frame: Forward a movie by one frame.</p> 
Forward	<p>This item is displayed only when [Forward 1 Frame] is selected in [Configure Switch]. While pressing the switch, specify whether to continuously forward a movie frame by frame.</p>
Backward	<p>This item is displayed only when [Back 1 Frame] is selected in [Configure Switch]. While pressing the switch, specify whether to continuously reverse a movie frame by frame.</p> 
Detail Action	<p>This item is displayed only when [Change Movie] is selected in [Configure Switch]. Select the operation for switching movies.</p> <p>Next Previous Play List</p> 
Loop	<p>This item is displayed only when [Change Movie] is selected in [Configure Switch], and [Next] or [Previous] is selected in [Details]. Specify whether to perform a loop operation.</p>
Index Number	<p>This item is displayed only when [Change Movie] is selected in [Configure Switch], and [Play List] is specified in [Details]. Specify the Index Number of the movie file to be played. The setting range is from 0 to 99.</p>
Action Mode	<p>This item is displayed only when [Zoom] is selected in [Configure Switch]. Select how to specify the display size from either [Direct] or [Indirect].</p>

Continued

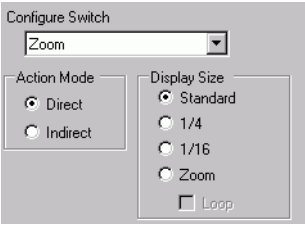
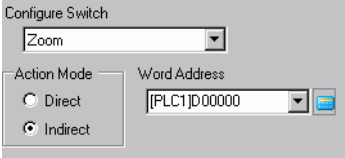
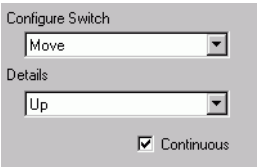
Setting		Description
Mode	Direct	<p>Select the display size from [Standard], [1/4], [1/16], or [Zoom]. For [Zoom], every time the switch is pressed, the movie is zoomed in the following steps. Standard-> 1/4 -> 1/16 -> 1/4 ->Standard</p>  <p>NOTE</p> <ul style="list-style-type: none"> When [Loop] is specified, the order is Standard-> 1/4 -> 1/16 ->Standard-> 1/4.
	Indirect	<p>Specify the address for storing the display size to indirectly zoom the movie. The following lists the values to be stored.</p> <p>0 Standard 11/4 21/16 3 - 0xFFFFE Reserved (does not change) 00xFFFFReturns to the original screen size.</p> <p>If a value other than the above is stored, the movie will not zoom.</p>  <p>NOTE</p> <ul style="list-style-type: none"> For a 32-bit device, only the bottom 16 bits are used.
	Detail Action	<p>This item is displayed only when [Move] is selected in [Configure Switch].</p> 

Continued

Setting		Description									
Detail Action	Direction	<p>Select the direction to move the movie from [Up], [Down], [Left], or [Right]. The following describes the range in which a movie can be moved at one time.</p> <table border="1"> <thead> <tr> <th></th> <th>When playing a movie</th> <th>When displaying video</th> </tr> </thead> <tbody> <tr> <td>Landscape direction</td> <td>2 dot unit</td> <td>2 dot unit</td> </tr> <tr> <td>Portrait direction</td> <td>Normal size : 2 dot units 1/4, 1/16 size : 1 dot unit</td> <td>1 dot unit</td> </tr> </tbody> </table>		When playing a movie	When displaying video	Landscape direction	2 dot unit	2 dot unit	Portrait direction	Normal size : 2 dot units 1/4, 1/16 size : 1 dot unit	1 dot unit
		When playing a movie	When displaying video								
Landscape direction	2 dot unit	2 dot unit									
Portrait direction	Normal size : 2 dot units 1/4, 1/16 size : 1 dot unit	1 dot unit									
	Continuous	While pressing the switch, specify whether to continuously move a movie.									
Switch Label	Font Type	<p>Select the font type for the label that displays on the switch.</p> <ul style="list-style-type: none"> • Standard Font The vertical and horizontal dimensions of a character can be specified in bitmap font. When a character is enlarged or reduced, the outline of the character may appear grainy or smudged. • Stroke Font This is an outline font where the ratio of the character height/width is fixed. Even when a character is enlarged or reduced, the outline clearly displays. However, due to the large required capacity, this font may put a burden on the GP. 									
	Display Language	Select the display language for the label displayed on the switch from among [ASCII], [Japanese], [Chinese (Traditional)], [Chinese (Simplified)], [Korean], [Cyrillic Alphabet], or [Thai].									
	Text Color	Select a color for the label text.									
	Label	Enter the text to display on the switch.									
Switch color	Border Color	If it exists, select a color for the Part Shape border.									
	Display Color	Select the Switch color.									
	Pattern	Select from the 8 patterns or choose [No Pattern].									
	Blink	<p>Select the Part blink and blink speed. You can set blink settings for the [Border Color] and [Display Color].</p> <p>NOTE</p> <ul style="list-style-type: none"> • There are cases where you can and cannot set Blink depending on the Display Unit and System Settings' [Color Settings]. <p> "8.5.1 Setting Colors ■ List of Compatible Colors" (page 8-36)</p>									

NOTE

- Depending on the shape, you may not be able to change the color.
- When you select a switch and press the [F2] key you can directly edit the Label text.

27.9.5 Common [Image Input Module Window Settings] Settings Guide

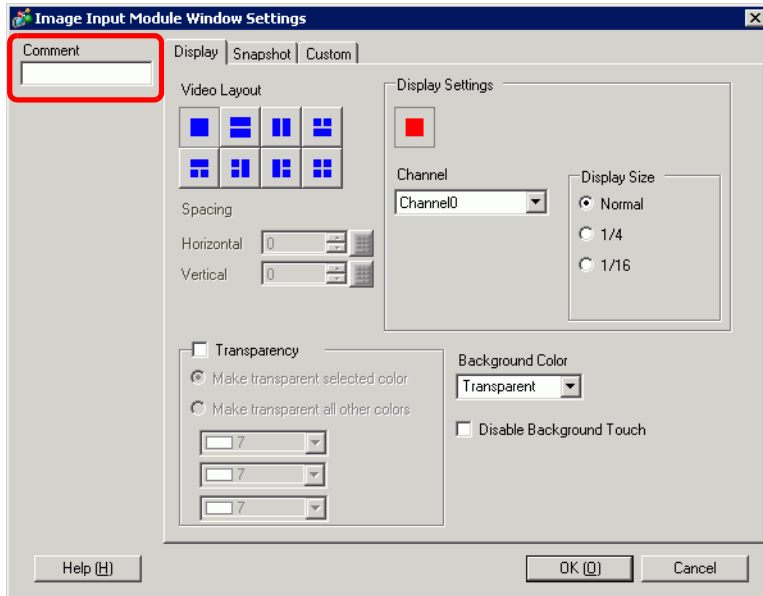

Setting	Description
Comment	The comment for each Part can be up to 20 characters.

NOTE

- When selecting [DVI Unit] in the [Image Input Module Settings] from the [System Settings] window, a portion of items in the [Image Input Module Window Settings] cannot be set. For more details, please refer to the following.
 ☞ "27.10.3 Restrictions on DVI Unit Features" (page 27-150)

■ Display

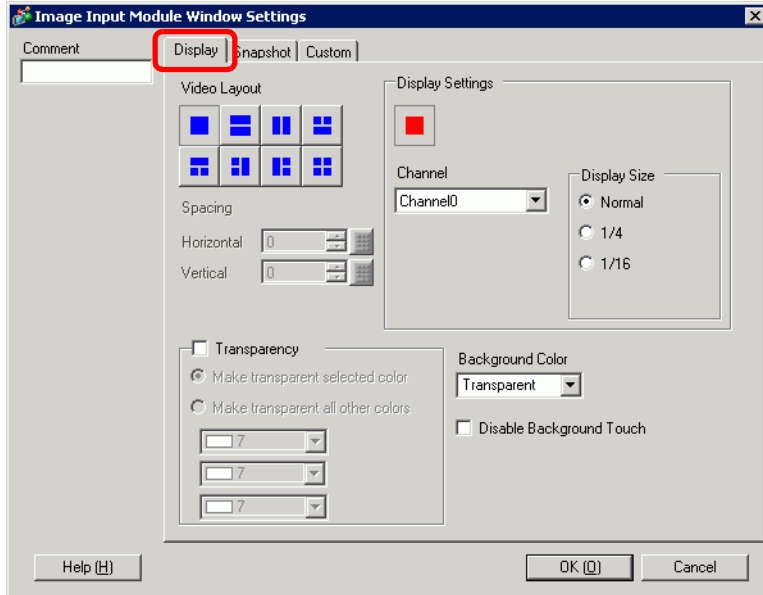

Setting	Description																
Video Layout	<p>Select the window display type.</p> <table border="0" style="width: 100%; text-align: center;"> <tr> <td data-bbox="410 913 605 1006"><Single screen></td> <td data-bbox="628 913 814 1006"><Two screens placed horizontally></td> <td data-bbox="834 913 1034 1006"><Two screens placed vertically></td> <td data-bbox="1055 913 1249 1006"><Three screens (One screen on the bottom)></td> </tr> <tr> <td data-bbox="429 1025 583 1180"></td> <td data-bbox="643 1025 797 1180"></td> <td data-bbox="858 1025 1012 1180"></td> <td data-bbox="1072 1025 1226 1180"></td> </tr> <tr> <td data-bbox="410 1193 605 1286"><Three screens (One screen on the top)></td> <td data-bbox="628 1193 814 1286"><Three screens (One screen on the right)></td> <td data-bbox="834 1193 1034 1286"><Three screens (One screen on the left)></td> <td data-bbox="1055 1193 1249 1286"><Four screens></td> </tr> <tr> <td data-bbox="429 1306 583 1460"></td> <td data-bbox="643 1306 797 1460"></td> <td data-bbox="858 1306 1012 1460"></td> <td data-bbox="1072 1306 1226 1460"></td> </tr> </table>	<Single screen>	<Two screens placed horizontally>	<Two screens placed vertically>	<Three screens (One screen on the bottom)>					<Three screens (One screen on the top)>	<Three screens (One screen on the right)>	<Three screens (One screen on the left)>	<Four screens>				
<Single screen>	<Two screens placed horizontally>	<Two screens placed vertically>	<Three screens (One screen on the bottom)>														
<Three screens (One screen on the top)>	<Three screens (One screen on the right)>	<Three screens (One screen on the left)>	<Four screens>														
Spacing	<p>Specify this setting when two or more screens are displayed simultaneously.</p> <ul style="list-style-type: none"> • Horizontal: Specify the number of pixels between windows side by side. • Vertical: Specify the number of pixels between windows on top of each other. <p>Each window size has different setup ranges.</p>																

Continued

Setting	Description																																		
Display	Specify the display settings for each screen according to the selected window type.																																		
Channel	Select a Channel Number on which the display settings are to be specified.																																		
Channel 0 to 3	Displays the video camera image input to the specified channel.																																		
Display size	<table border="1" data-bbox="408 367 1245 768"> <thead> <tr> <th rowspan="2">Display Size</th> <th colspan="3">NTSC</th> <th colspan="3">PAL</th> </tr> <tr> <th>AGP- 35*0T</th> <th>AGP- 36*0T</th> <th>AGP- 37*0T</th> <th>AGP- 35*0T</th> <th>AGP- 36*0T</th> <th>AGP- 37*0T</th> </tr> </thead> <tbody> <tr> <td>Normal</td> <td>640 x 480 pixels</td> <td>640 x 480 pixels</td> <td>640 x 480 pixels</td> <td>640 x 480 pixels*¹</td> <td>768 x 576 pixels</td> <td>768 x 576 pixels</td> </tr> <tr> <td>1/4</td> <td>320 x 240 pixels</td> <td>320 x 240 pixels</td> <td>320 x 240 pixels</td> <td>384 x 288 pixels</td> <td>384 x 288 pixels</td> <td>384 x 288 pixels</td> </tr> <tr> <td>1/16</td> <td>160 x 120 pixels</td> <td>160 x 120 pixels</td> <td>160 x 120 pixels</td> <td>192 x 144 pixels</td> <td>192 x 144 pixels</td> <td>192 x 144 pixels</td> </tr> </tbody> </table> <p data-bbox="408 776 1190 842">*1 When selecting [PAL] and [Normal] in the AGP-35*0T, some parts of the picture will appear.</p> <p data-bbox="408 880 491 919">NOTE</p> <ul data-bbox="408 927 1190 958" style="list-style-type: none"> • AGP-3510 and AGP-3560 work in the same way as AGP-36*0T. 	Display Size	NTSC			PAL			AGP- 35*0T	AGP- 36*0T	AGP- 37*0T	AGP- 35*0T	AGP- 36*0T	AGP- 37*0T	Normal	640 x 480 pixels	640 x 480 pixels	640 x 480 pixels	640 x 480 pixels* ¹	768 x 576 pixels	768 x 576 pixels	1/4	320 x 240 pixels	320 x 240 pixels	320 x 240 pixels	384 x 288 pixels	384 x 288 pixels	384 x 288 pixels	1/16	160 x 120 pixels	160 x 120 pixels	160 x 120 pixels	192 x 144 pixels	192 x 144 pixels	192 x 144 pixels
Display Size	NTSC			PAL																															
	AGP- 35*0T	AGP- 36*0T	AGP- 37*0T	AGP- 35*0T	AGP- 36*0T	AGP- 37*0T																													
Normal	640 x 480 pixels	640 x 480 pixels	640 x 480 pixels	640 x 480 pixels* ¹	768 x 576 pixels	768 x 576 pixels																													
1/4	320 x 240 pixels	320 x 240 pixels	320 x 240 pixels	384 x 288 pixels	384 x 288 pixels	384 x 288 pixels																													
1/16	160 x 120 pixels	160 x 120 pixels	160 x 120 pixels	192 x 144 pixels	192 x 144 pixels	192 x 144 pixels																													
RGB (IN)	Displays an image from a device connected via an RGB interface.																																		
Emulate Touch	<p data-bbox="400 1012 1237 1070">Sends the screen touch information to an external device connected via serial communication.</p> <p data-bbox="400 1078 1237 1143">The following lists the maximum effective area of the X/Y coordinates for the entire screen display.</p> <p data-bbox="422 1151 1133 1178">For AGP-35*0T, X coordinate: 0 - 639, Y coordinate: 0-479</p> <p data-bbox="422 1186 1146 1213">For AGP-36*0T, X coordinate: 0 - 799, Y coordinate: 0 - 599</p> <p data-bbox="422 1221 1146 1248">For ACP-3750T, X coordinate: 0 - 1023, Y coordinate: 0-767</p>																																		

Continued

Setting		Description																																																	
Display Channel	RGB (IN) Display size	<p>The following table lists the display sizes according to the models and display mode settings.</p> <table border="1"> <thead> <tr> <th rowspan="2">Display Size</th> <th colspan="3">AGP-35*0T</th> <th colspan="3">AGP-36*0T</th> <th colspan="3">AGP-37*0T</th> </tr> <tr> <th>VGA</th> <th>SVGA</th> <th>XGA</th> <th>VGA</th> <th>SVGA</th> <th>XGA</th> <th>VGA</th> <th>SVGA</th> <th>XGA</th> </tr> </thead> <tbody> <tr> <td>Normal</td> <td>640 x 480 pixels</td> <td>640 x 480 pixels *1</td> <td>640 x 480 pixels</td> <td>640 x 480 pixels</td> <td>800 x 600 pixels</td> <td>800 x 600 pixels *2</td> <td>640 x 480 pixels</td> <td>800 x 600 pixels</td> <td>1024 x 768 pixels</td> </tr> <tr> <td>1/4</td> <td>320 x 240 pixels</td> <td>400 x 300 pixels</td> <td>400 x 300 pixels</td> <td>320 x 240 pixels</td> <td>400 x 300 pixels</td> <td>512 x 384 pixels</td> <td>320 x 240 pixels</td> <td>400 x 300 pixels</td> <td>512 x 384 pixels</td> </tr> <tr> <td>1/16</td> <td>160 x 120 pixels</td> <td>200 x 150 pixels</td> <td>200 x 150 pixels</td> <td>160 x 120 pixels</td> <td>200 x 150 pixels</td> <td>256 x 192 pixels</td> <td>160 x 120 pixels</td> <td>200 x 150 pixels</td> <td>256 x 192 pixels</td> </tr> </tbody> </table> <p>*1 If the display mode is SVGA, [Normal] size on AGP35*0T will cause cropping of part of the image.</p> <p>*2 If the display mode is set to XGA, [Normal] size on AGP-35*0T or AGP-36*0T will cause cropping of part of the image.</p> <p>NOTE</p> <ul style="list-style-type: none"> AGP-3510 and AGP-3560 work in the same way as AGP-36*0T. 	Display Size	AGP-35*0T			AGP-36*0T			AGP-37*0T			VGA	SVGA	XGA	VGA	SVGA	XGA	VGA	SVGA	XGA	Normal	640 x 480 pixels	640 x 480 pixels *1	640 x 480 pixels	640 x 480 pixels	800 x 600 pixels	800 x 600 pixels *2	640 x 480 pixels	800 x 600 pixels	1024 x 768 pixels	1/4	320 x 240 pixels	400 x 300 pixels	400 x 300 pixels	320 x 240 pixels	400 x 300 pixels	512 x 384 pixels	320 x 240 pixels	400 x 300 pixels	512 x 384 pixels	1/16	160 x 120 pixels	200 x 150 pixels	200 x 150 pixels	160 x 120 pixels	200 x 150 pixels	256 x 192 pixels	160 x 120 pixels	200 x 150 pixels	256 x 192 pixels
		Display Size		AGP-35*0T			AGP-36*0T			AGP-37*0T																																									
			VGA	SVGA	XGA	VGA	SVGA	XGA	VGA	SVGA	XGA																																								
		Normal	640 x 480 pixels	640 x 480 pixels *1	640 x 480 pixels	640 x 480 pixels	800 x 600 pixels	800 x 600 pixels *2	640 x 480 pixels	800 x 600 pixels	1024 x 768 pixels																																								
1/4	320 x 240 pixels	400 x 300 pixels	400 x 300 pixels	320 x 240 pixels	400 x 300 pixels	512 x 384 pixels	320 x 240 pixels	400 x 300 pixels	512 x 384 pixels																																										
1/16	160 x 120 pixels	200 x 150 pixels	200 x 150 pixels	160 x 120 pixels	200 x 150 pixels	256 x 192 pixels	160 x 120 pixels	200 x 150 pixels	256 x 192 pixels																																										
JPG		<p>Display JPEG files on the CF card. You can specify multiple settings for displaying JPEG images on the same screen and select [JPG File Number] redundantly.</p> <p>NOTE</p> <ul style="list-style-type: none"> Even if an attempt is made to turn OFF the video screen while a JPEG image is displayed, the screen will not turn OFF until the display processing has completed. In addition to a CF card, you can display the files in a USB storage device. In the System Settings, select [Display Unit] and click the [Mode] tab. In the [Screen Capture Settings], select the [Capture Action] check box. When you select the files to be saved in a USB storage device, the files in the USB storage device will be displayed. When selecting FTP Server, the CF Card will be selected. 																																																	
	JPG file number	Specify the JPEG file number for the file you want to display from 0 to 65535.																																																	
	Display size	Select the screen display size from [Normal], [1/4], [1/16] and [1/64]. The percentage of reduction is based on the display screen size, not the display mode.																																																	

Continued

Setting	Description
Transparency	From the color pallet, select the color that will be seen through the window from the display on the GP screen. It is not possible to set the colors for each image to be displayed. <ul style="list-style-type: none">• Make transparent selected color: Up to three colors can be selected.• Make transparent all other colors: Only one color can be selected.
Background Color	Select the background color for the Image Input Module Window.
Disable Background Touch	Specify whether to enable the touch switch on the GP screen displayed behind the Image Input Module window.

■ Capture

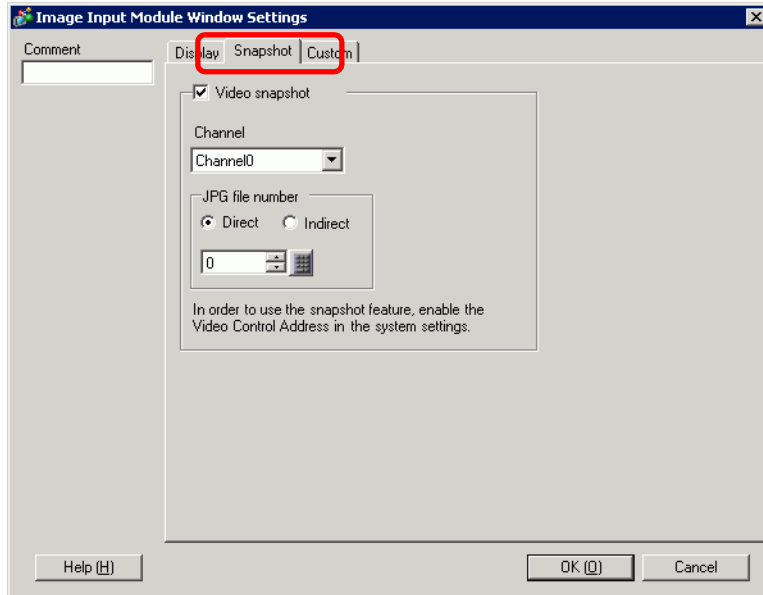

Setting		Description
Video capture		<p>Captures a shot of the video from a single channel and specifies whether to save it to the CF card as a JPG file.</p> <p>Using Capture Output, the picture from the channel specified in the [Image Input Module Window Settings] is output in JPEG format. The size of the output image is 640x480 pixels for NTSC and 768x576 for PAL signals.</p> <p>IMPORTANT</p> <ul style="list-style-type: none"> To use the video capture feature, in the System Settings window's [Image Input Module Settings] page, [enable] the [Video Control Start Address]. In the defined video address, turn ON bit 4 to initiate the video capture.
	Capture Channel	Select the channel to capture.
JPG file number	Direct	<p>Set a number to be the JPEG file name. The setting range is from 0 to 65535.</p> <p>The saved file name is "CPXXXXX.JPG" (XXXXXX is the specified value). The file will be stored in the "CAPTURE" folder the CF card.</p> <p>NOTE</p> <ul style="list-style-type: none"> The file is always saved using the file name defined here. If a file with the same name already exists in the CF card, that file will be overwritten. In the system settings window, select [Display Unit] and click the [Mode] tab. From [Screen Capture Settings], select the [Capture Action] check box. When you select the files saved in the FTP server, this setting is disabled. In this case, the file number will be time stamp (year, month, day, hours, minutes, seconds).

Continued

Setting		Description																																
Video capture JPG file number	Indirect	<p>Stores the file number to: [Video Control Address] + +2 specified in the system settings [Image Input Module Settings].</p> <p>NOTE</p> <ul style="list-style-type: none"> When the files are saved in the CF card or USB storage, you can automatically add and delete file numbers in the System Settings. In the System settings, select [Display Unit] and click the [Mode] tab. From [Screen Capture Settings], go to [Screen/Video Capture Settings] to set up your options. In the system settings window, select [Display Unit] and click the [Mode] tab. From [Screen Capture Settings], select the [Capture Action] check box. When you select the files saved in the FTP server, this setting is disabled. In this case, the file number will be time stamp (year, month, day, hours, minutes, seconds). 																																
	Indirect	<p>JPEG error code</p> <table border="1"> <thead> <tr> <th>Number</th> <th>Description</th> <th>Introduction</th> </tr> </thead> <tbody> <tr> <td>0</td> <td>Completed Successfully</td> <td>Processing successfully completed.</td> </tr> <tr> <td>1</td> <td>The JPEG image size exceeds 1024 x 768 pixels.</td> <td>An attempt was made to display a JPEG image with an image size of 1024 x 768 pixels or more. *1</td> </tr> <tr> <td>2</td> <td>Unsupported sample ratio</td> <td>An attempt was made to display a JPEG image created with an unsupported sample ratio.</td> </tr> <tr> <td>3</td> <td>Other compression/ decompression error</td> <td>An internal error occurred due to an unknown reason while taking a capture (compressing) or while displaying (expanding) a JPEG image.</td> </tr> <tr> <td>4</td> <td>No CF Card</td> <td>A CF Card was not inserted at the time of displaying or taking a capture, or the CF Card hatch is open.</td> </tr> <tr> <td>5</td> <td>CF Write Error</td> <td>The CF Card capacity was not sufficient at the time of taking the capture, or the CF Card was ejected while it was being written.</td> </tr> <tr> <td>6</td> <td>CF Read Error</td> <td>The display file did not exist at the time of displaying the JPEG image, or the CF Card was ejected while it was being read.</td> </tr> <tr> <td>7</td> <td>CF Card Error</td> <td>The CF Card is not formatted.</td> </tr> <tr> <td>8</td> <td>The video image cannot be saved.</td> <td>When saving a video image in PAL, only the actual image size can be specified. If the size is specified as 1/4 or 1/16, the video image cannot be saved. If the revision Number of the Video Module/DVI Unit is Rev.A-2 or higher, an error will not occur and the video image can be saved.</td> </tr> <tr> <td>9</td> <td>Automatic Increment File Count Error</td> <td>When the [File Automatic Increment Function] is enabled in the system settings, and the JPEG file Number of the video capture was indirectly designated, an error will occur if the file Number exceeds 65535.</td> </tr> </tbody> </table> <p>*1 An error occurs when the size of the expanded JPEG file exceeds 1024 x 768 pixels. It does not depend on the original JPEG image file. An error does not occur for JPEG files with 1024 x 768 pixels or more if the size is below 1024 x 768 pixels in the 1/4, 1/16, or 1/64 setting.</p>	Number	Description	Introduction	0	Completed Successfully	Processing successfully completed.	1	The JPEG image size exceeds 1024 x 768 pixels.	An attempt was made to display a JPEG image with an image size of 1024 x 768 pixels or more. *1	2	Unsupported sample ratio	An attempt was made to display a JPEG image created with an unsupported sample ratio.	3	Other compression/ decompression error	An internal error occurred due to an unknown reason while taking a capture (compressing) or while displaying (expanding) a JPEG image.	4	No CF Card	A CF Card was not inserted at the time of displaying or taking a capture, or the CF Card hatch is open.	5	CF Write Error	The CF Card capacity was not sufficient at the time of taking the capture, or the CF Card was ejected while it was being written.	6	CF Read Error	The display file did not exist at the time of displaying the JPEG image, or the CF Card was ejected while it was being read.	7	CF Card Error	The CF Card is not formatted.	8	The video image cannot be saved.	When saving a video image in PAL, only the actual image size can be specified. If the size is specified as 1/4 or 1/16, the video image cannot be saved. If the revision Number of the Video Module/DVI Unit is Rev.A-2 or higher, an error will not occur and the video image can be saved.	9	Automatic Increment File Count Error
Number	Description	Introduction																																
0	Completed Successfully	Processing successfully completed.																																
1	The JPEG image size exceeds 1024 x 768 pixels.	An attempt was made to display a JPEG image with an image size of 1024 x 768 pixels or more. *1																																
2	Unsupported sample ratio	An attempt was made to display a JPEG image created with an unsupported sample ratio.																																
3	Other compression/ decompression error	An internal error occurred due to an unknown reason while taking a capture (compressing) or while displaying (expanding) a JPEG image.																																
4	No CF Card	A CF Card was not inserted at the time of displaying or taking a capture, or the CF Card hatch is open.																																
5	CF Write Error	The CF Card capacity was not sufficient at the time of taking the capture, or the CF Card was ejected while it was being written.																																
6	CF Read Error	The display file did not exist at the time of displaying the JPEG image, or the CF Card was ejected while it was being read.																																
7	CF Card Error	The CF Card is not formatted.																																
8	The video image cannot be saved.	When saving a video image in PAL, only the actual image size can be specified. If the size is specified as 1/4 or 1/16, the video image cannot be saved. If the revision Number of the Video Module/DVI Unit is Rev.A-2 or higher, an error will not occur and the video image can be saved.																																
9	Automatic Increment File Count Error	When the [File Automatic Increment Function] is enabled in the system settings, and the JPEG file Number of the video capture was indirectly designated, an error will occur if the file Number exceeds 65535.																																

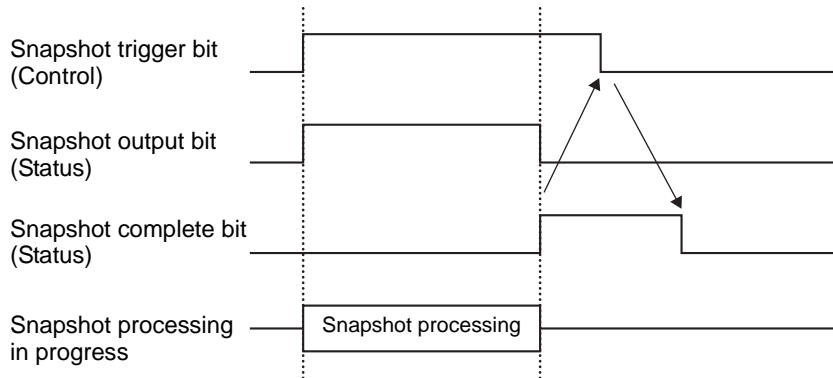
◆ Video Capture Timing Chart





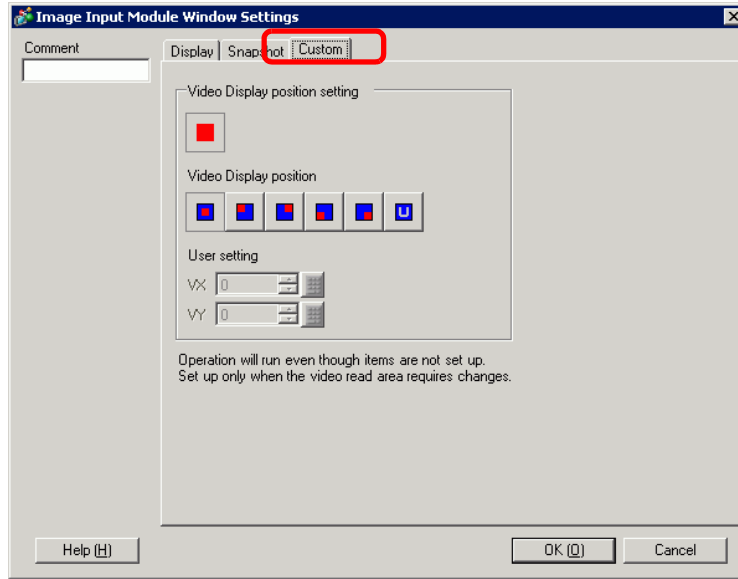

Even if the trigger bit turns OFF before the snapshot complete bit turns ON, the snapshot complete bit automatically turns OFF.

■ Custom Settings

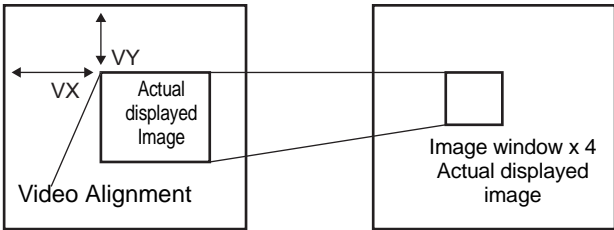

Setting	Description
<p>Video Alignment</p>	<p>Specify which part of the actual image should be displayed.</p> <ul style="list-style-type: none"> To display normally Creates a movie window for the movie size starting from (0,0) To display part of the movie Specifies the necessary position and creates a video window. <p>Base Screen Relationship Between the Video Screen and Video Settings</p> <p>The video screen is displayed on the base screen. The part called video settings is placed on the video screen, and the image is displayed only in the video settings.</p> <p>Video settings (1 channel display, normal) When the display size is normal, the size of the actual displayed image is equal to the size of the image window in the video settings.</p>

Continued

Setting	Description
<p>Video Alignment</p>	 <p>Video image /RGB image</p> <p>Video settings channel display, 1/4 (reduced display)</p> <p>When the display size is reduced (1/4), the size of the actual displayed image is four times as large as the size of the image window in the video settings (for 1/16, the size is 16 times larger).</p>
<p>Video Display position</p>	<p>For each display screen, select the video display position from ,</p> <p>, , , and .</p> <p>If  is selected, the X/Y coordinates can be specified.</p> <ul style="list-style-type: none"> • VX: Specify from 0 to 1023. • VY: Specify from 0 to 767.

27.9.6 [Image Input Module] Settings Guide

This section describes the basic settings of the optional Video Module or DVI unit.

■ Display Settings/Basic

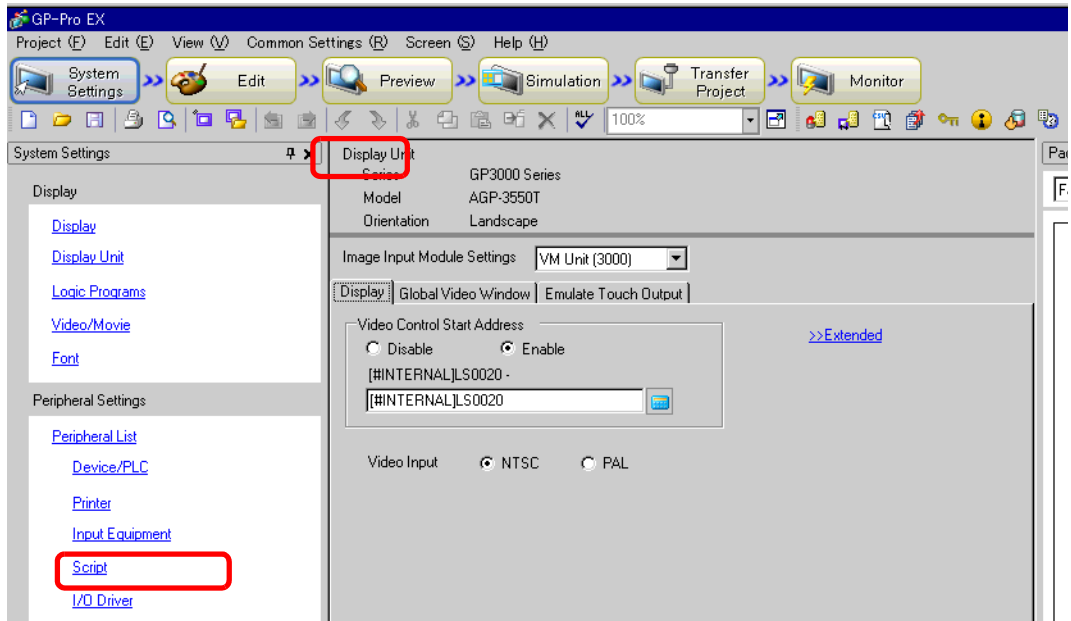

Setting	Description
Image Input Module Settings	<p>Select whether to use [VM Unit (2000)], [VM Unit (3000)], or [DVI Unit].</p> <p>NOTE</p> <ul style="list-style-type: none"> When [DVI Unit] is selected, some features may be disabled. <p>☞ "27.10.3 Restrictions on DVI Unit Features" (page 27-150)</p>
Video Control Start Address	<p>Specifies whether or not to use the control address.</p>
Disable	<p>Does not use the control address.</p>
Enable	<p>Set the GP internal device address for controlling the display of the Image Input Module Window. Use a sequence of 42 Words from the specified address.</p> <p>The settings range for the video module unit is between LS20 - 1989 and 2096 - 8957, and for the DVI unit is between LS20 - 2026 and 2096 - 8894.</p> <p>☞ " ◆ Video Control Area" (page 27-130)</p> <p>NOTE</p> <ul style="list-style-type: none"> If an address is specified outside of the settings range, the VM function will not run.
Video Signal	<p>Select the image input signal.</p> <ul style="list-style-type: none"> NTSC: 640 x 480 pixels PAL: 768 x 576 pixels

◆ Video Control Area

The sequence of 42 Words from the specified [Video Control Start Address] is called the "video control area". The following tables lists what each address controls.

NOTE

- The video control area processes data in 16 bits.
- The settings specified in [Image Input Module Window Settings] in the Common Settings are written in the video control area.

Word Address	Description	Bit	Introduction
+0	Video Common Control Command	0	(0:OFF, 1: ON)
		1	Transparent execution mode (0: Transparently displays colors other than those specified, 1: Transparently displays the specified color.)
		2	Touch input is prohibited in the window. (0: Enables input, 1: Prohibits input.)
		3	Unused (Reserved)
		4	Capture output (0: None, 1: Start)
		5 to 15	Unused (Reserved)
+1	Video Common Control Status	0 to 1	Capture status (0: None, 1: Capture in progress, 2: Capture complete.)
		2 to 11	Unused (Reserved)
		12 to 15	JPEG error codes
+2	JPEG file Number	0 to 65535	
+3	Transparent color 1	0 to 2550 - 255, 0x8001 - 0x800C (E1 - E12)	
+4	Transparent color 2	0 to 255, 0 - 255, 0x8001 - 0x800C (E1 - E12)	
+5	Transparent color 3	0 to 255, 0 - 255, 0x8001 - 0x800C (E1 - E12)	
+6	Image window display control	0 to 3	Image window 0 0: External input device, 1: JPEG normal, 2: JPEG 1/4 expanded, 3: JPEG 1/16 expanded, 4: JPEG1 1/64 expanded, 5 - F: Reserved
		4 to 7	Image window 1 0: External input device, 1: JPEG normal, 2: JPEG 1/4 expanded, 3: JPEG 1/16 expanded, 4: JPEG1 1/64 expanded, 5 - F: Reserved

Continued

Word Address	Description	Bit	Introduction
+6	Image window display control	8 to 11	Image window 2 0: External input device, 1: JPEG normal, 2: JPEG 1/4 expanded, 3: JPEG 1/16 expanded, 4: JPEG1 1/64 expanded, 5 - F: Reserved
		12 to 15	Image window 3 0: External input device, 1: JPEG normal, 2: JPEG 1/4 expanded, 3: JPEG 1/16 expanded, 4: JPEG1 1/64 expanded, 5 - F: Reserved
+7	Image window 0	JPEG file Number	
+8	Image window 1	JPEG file Number	
+9	Image window 2	JPEG file Number	
+10	Image window 3	JPEG file Number	
+11	Internal image window control flag (When the bit is ON, the operation described on the right is performed.)	0	Updates the coordinate position.
		1	Unused (Reserved)
		2	UP
		3	DOWN
		4	RIGHT
		5	LEFT
		6	Unused (Reserved)
		7	Unused (Reserved)
		8	Updates the color value.
		9	Unused (Reserved)
		10	Increases the color value by increments.
		11	Decreases the color value by increments.
		12	Brightness adjustment mode
		13	Contrast adjustment mode
14	Color tone adjustment mode		
15	Unused (Reserved)		

Continued

Word Address	Description	Bit	Introduction			
+12	Internal video control channel Number		Channel 0 Channel 1 Channel 2 Channel 3 RGB display			
+13	Video window Control Command*1	Video channel 0 information	0	Video display mode (0: Normal mode, 1: 1/4 mode, 2: 1/16 mode, 3: Reserved)		
			1			
			2	Still (video still image) (0: Movie, 1: Still image)		
			3 to 15	Unused (Reserved)		
			+14	Video alignment (VX)	NTSC: 0 - 639, PAL: 0 - 767	
			+15	Video alignment (VY)	NTSC: 0 - 479, PAL: 0 - 575	
			+16	Brightness	(Low<->High: 0 to 15)	
			+17	Contrast	(Low<->High: 0 to 15)	
+18	Tone	(Green<->Red: 0 to 15)				
+19	Video window Control Command*1	Video channel 1 information	0	Video display mode (0: Normal mode, 1: 1/4 mode, 2: 1/16 mode, 3: Reserved)		
			1			
			2	Still (video still image) (0: Movie, 1: Still image)		
			3 to 15	Unused (Reserved)		
			+20	Video alignment (VX)	NTSC: 0 - 639, PAL: 0 - 767	
			+21	Video alignment (VY)	NTSC: 0 - 479, PAL: 0 - 575	
			+22	Brightness	(Low High: 0 to 15)	
			+23	Contrast	(Low High: 0 to 15)	
+24	Tone	(Green <-> Red: 0 to 15)				
+25	Video window Control Command*1	Video channel 2 information	0	Video display mode (0: Normal mode, 1: 1/4 mode, 2: 1/16 mode, 3: Reserved)		
			1			
			2	Still (video still image) (0: Movie, 1: Still image)		
			3 to 15	Unused (Reserved)		

Continued

Word Address	Description	Bit	Introduction	
+26	Video alignment (VX)		NTSC: 0 - 639, PAL: 0 - 767	
+27	Video alignment (VY)		NTSC: 0 - 479, PAL: 0 - 575	
+28	Brightness		(Low<->High: 0 to 15)	
+29	Contrast		(Low<->High: 0 to 15)	
+30	Tone		(Green <-> Red: 0 to 15)	
+31	Video window Control Command*1	Video channel information	0	Video display mode (0: Normal mode, 1: 1/4 mode, 2: 1/16 mode, 3: Reserved)
			1	
			2	Still (video still image) (0: Movie, 1: Still image)
			3 to 15	Unused (Reserved)
+32	Video alignment (VX)		NTSC: 0 - 639, PAL: 0 - 767	
+33	Video alignment (VY)		NTSC: 0 - 479, PAL: 0 - 575	
+34	Brightness		(Low<->High: 0 to 15)	
+35	Contrast		(Low<->High: 0 to 15)	
+36	Tone		(Green<->Red: 0 to 15)	
+37	Video window Control Command*1	RGB display information	0	Video display mode (0: Normal mode, 1: 1/4 mode, 2: 1/16 mode, 3: Reserved)
			1	
			2	Still (video still image) (0: Movie, 1: Still image)
			3 to 15	Unused (Reserved)
+38	RGB alignment (VX)		VGA: 0 - 639, SVGA: 0 to 799, XGA: 0 to 1023	
+39	RGB alignment (VY)		VGA: 0 - 479, SVGA: 0 to 599, XGA: 0 to 767	
+40	Reserved		Unused (Reserved)	
+41	Reserved		Unused (Reserved)	
+42	Reserved		Unused (Reserved)	

*1 When using a video window control command, note the following points:

IMPORTANT

- The size of the video display cannot be changed while the video is paused and a still image is displayed.
- If an attempt is made to output a capture while the video is paused and a still image is displayed, a capture of the still screen will be taken.
- While the video is paused to display a still image after switching the image window display settings from video picture to JPEG display, in order to switch the settings back to video picture, first cancel the still image and then switch the settings.

Video common control command (Word Address + 0)

The video common control command (address + 0) is used to control the operations in the Image Input Module window. The following describes the control operations

- When the window is displayed, this address area is initialized to the specified value by the Image Input Module window.
- The following describes the settings when Transparency is enabled.
 - The color specified for transparency uses the data from the Word Addresses +3 to +5. If the color does not use the data, FFFF(h) is stored in the Word Addresses +3 to +5. Also, in modes for Transparency displaying a color other than the specified color, only the transparent color 1 (Word Address +3) is valid.
 - The range for a color specified for transparency is from 0 to 255 and from E1 to E12. When specifying from E1 to E12, set 0x8000 + number. (For example, for E5 set 0x8005.)
 - The transparent color is acquired from the most significant bit and lower eight bits. Other bits are disabled. Also, when specifying E0 and from E13 to E255, the transparent color is disabled.
- While taking a capture, processing of parts and video display are stopped.
- If the same file exists on the CF Card, the existing file will be overwritten.
- It takes approximately three to five seconds to take a capture (when the image quality is 80).

Video common control status (Word Address +1)

The video common control status (address + 1) writes the results of the operation in the Image Input Module window.

- The capture status is ON when taking a capture of a JPEG file.
- When an error occurs during a capture or JPEG image display, the error code is stored. This error code is stored until the next capture.
For details on JPEG error codes, refer to " ■ Capture" (page 27-124)

Image window display control (Word Address +6)

Defines the image to display in the Image Input Module window.

- You can select either video image or JPEG image. If you select a video picture, it is displayed on the specified channel by the Video Modules/DVI Unit window. For JPEG images, specify the JPEG file number for each channel. You can select to zoom out from the JPEG image.

- In addition to the CF card, JPEG images can also be displayed using the files in a USB storage device. In the System Settings, select [Display Unit] and click the [Mode] tab. In the [Screen Capture Settings], select the [Capture Action] check box. When you select the files to be saved in a USB storage device, the files in the USB storage device will be displayed. When you select a CF card, the folder will be the CF card even when you select an FTP server.
- The Video Module can display a JPEG image up to 1024 x 768. If the JPEG image is larger than this, then the image is reduced to 1024 x 768 or to the display size specified of either 1/4, 1/6, or 1/64. For an SVGA model, a display size of up to 800 x 600 can be accommodated, and for a VGA model, a display size of up to 640 x 480 can be accommodated, and for an XGA model, a display size of up to 1024 x 768 can be accommodated.. If the image size exceeds the screen size, only part of the image that fits on the screen can be displayed.
- When JPEG is set as the initial display, it is not possible to switch between video image and JPEG image using the window display image control flag.
- When a JPEG image is being saved, it is not possible to zoom out (reduce).

Internal Image Window Screens Control Flag (Word Address+11) / Internal Video Control Channel Number (Word Address+12)

This is the address area for changing the display state of a video picture.

After storing in the internal video channel number in Word Address+12, the control flag is changed to Word Address+11.

- Once the coordinate position update bit is ON, the display changes to real time at the coordinate value until the bit turns OFF. When the show window is ON, the area is 0 and cleared.
- The video picture display is changed to the settings specified in the bits for UP, DOWN, RIGHT, LEFT, and the plus/minus color value.
- When the Color Value Update Bit is ON, it changes the specified values for brightness, contrast and color of the display that are written in the video channel information (Word Address +13 to +36) until the bit turns OFF.
- The bit for the plus/minus color value changes the settings for the parameters that are turned ON among the bits for brightness, contrast, and color tone. (These three parameters can be changed simultaneously.)
- After prohibiting touch-panel input in the Image Input Module window, if the Image Input Module display is OFF, touch-panel input is enabled.

Video Channel Information (Word Address +13 to +36) /RGB Display Information (Word Address +37 to +42)

Set the display origin, brightness, contrast and color of each video channel 0 - 3 and RGB display.

- Specify which part of the screen to display with the origin point's VX,VY coordinates. Base these coordinates on the video mode and window size.

When Video Input = NTSC, Display Size = Normal

Specify the Width of Video Image + Display Origin (VX) and Height of Video Image + Display Origin (VY) so as to not exceed the window size.

(Width of Video Image + VX ≤ 640, Width of Video Image + VY ≤ 480)

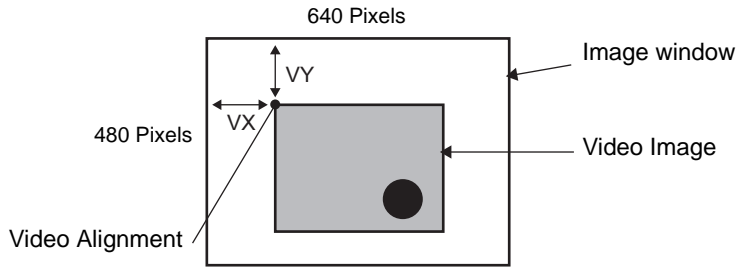

In case of Video Input "NTSC", Display Size "1/4".

Specify the Double Width of Video Image + Display Origin (VX) and Double Height of Video Image + Display Origin (VY) so as to not exceed the window size.

Width of Video Image x 2 + VX ≤ 640, Width of Video Image x 2 + VY ≤ 480

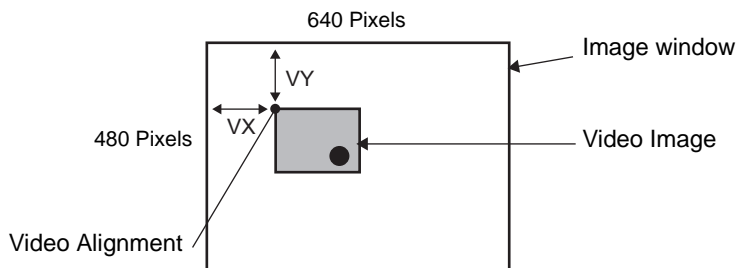

In case of Video Input "NTSC", Display Size "1/16".

Specify the Quadruple Width of Video Image + Display Origin (VX) and Quadruple Width of Video Image + Display Origin (VY) so as to not exceed the window size.

Width of Video Image x 4 + VX ≤ 640, Width of Video Image x 4 + VY ≤ 480
(For example, Video Input "NTSC")

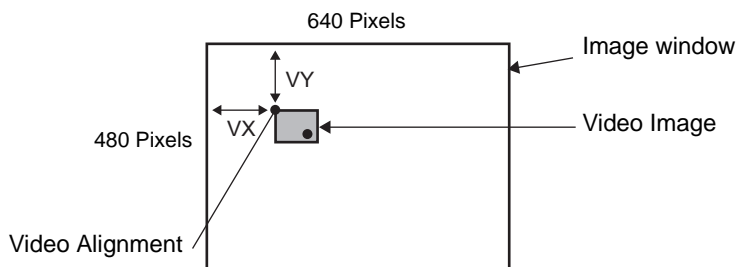

◆ Example use of the Video Control Area

This section gives an example of an operation using the video control area.

Displaying the JPEG file on the CF Card

Display the video capture image "CP00005" saved on the CF Card on Channel 2.

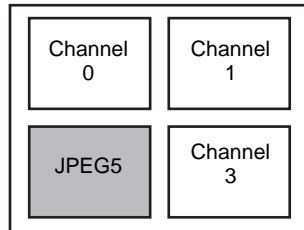

Write the JPEG file number "5" in [Video Control Start Address]+9 (Image Window2).
Write the display size "2" (JPEG 1/4 extension) in the bit 8 -11 of [Video Control Start Address]+6 (Image Window Display Control).

Changing the display size of the Image Window Screen

Change the display size of Channel 2 from Standard to 1/4.

Write "1" (Display Size:1/4 mode) the bit 0 - 1 of [Video Control Start Address]+25 (Video Window Control Command).

Creating a still image

Create a still image from an image on Channel 2.

Turn ON bit 2 of [Video Control Start Address]+25 (Video Window Control Command of Channel2).

Changing the Video Display position settings

Change the Channel 2 display origin from (0,0) to (100,100).

Turn ON bit 0 (Coordinate Position Update) of [Video Control Start Address]+11 (Internal Image Window Screens Control Flag).

Write "100" in 2.[Video Control Start Address]+26 (Video Display position settings VX of Channel 2) and +27 (Video Display position settings VY of Channel 2).

Changing the Transparent Color

Turn ON bit 0 (Transparency) of [Video Control Start Address]+0 (Video Common Control Command).

Turn ON bit 1 (Specified Color in Transparency) [Video Control Start Address]+0.

Write the color code in [Video Control Start Address]+3 - 5.

■ Display Settings/Details

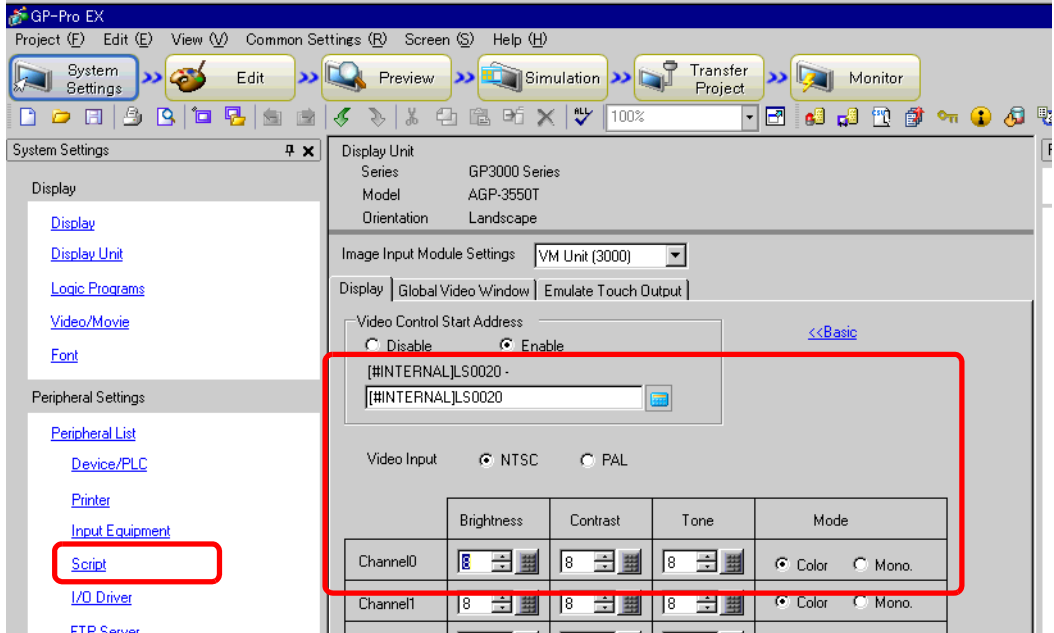

Setting	Description
Channels 0 - 3	Set the screen display state for each channel set up in the [Common Settings] menu's [Image Input Module Window Settings].
Brightness	Set the brightness. The setting range is from 0 to 15.
Contrast	Set the contrast. The setting range is from 0 to 15.
Tone	Set the tone. The setting range is from 0 to 15.
Mode	Video input mode from either [Color] or [Mono].

■ Global Video Window

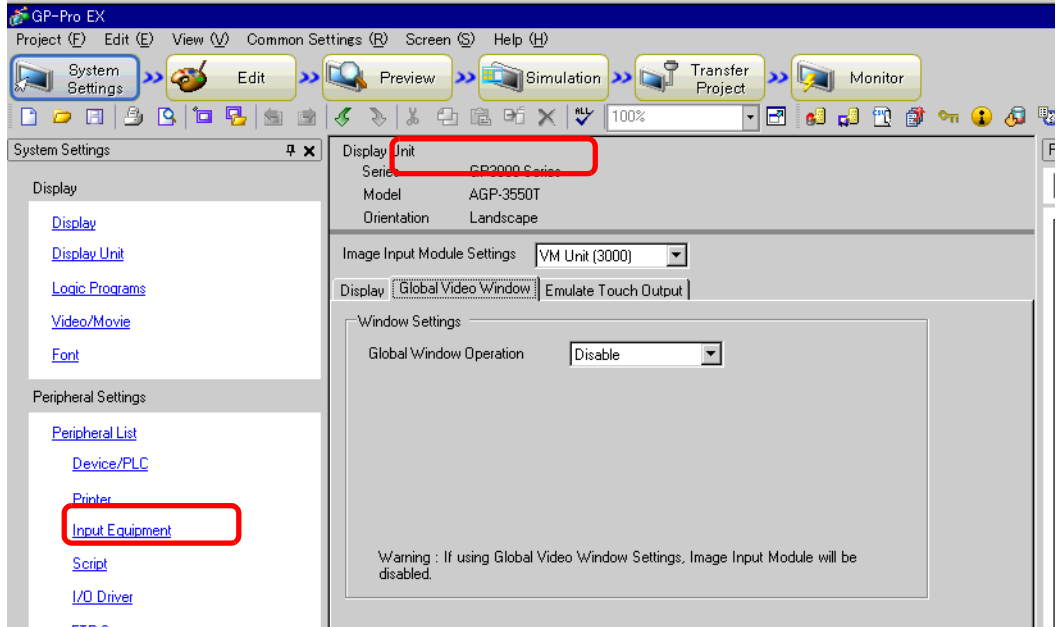

Setting		Description
Global Window Operation	Disable	Does not use Global Video Window.
	Direct	Specify a fixed Video Module /DVI Unit window number and display position.
	Control Bit Address	Specify the address for displaying/hiding a window.
	Window Number	Specify the Video Module/DVI window number. The setting range is from 1 to 512.
	Display Position X-Coordinate	Specify the window display position's X coordinate. The setting range is from 0 to 1,020. The range differs depending on the model of your display unit.
	Display Position Y-Coordinate	Specify the window display position's Y coordinate. The setting range is from 0 to 767. The range differs depending on the model of your display unit.
	Window Interchange	Specifies whether to switch from the foreground to the background by touching the windows when the windows overlap. By selecting [Always On Top], the Image Input Module window is always displayed on top regardless of the order in which the windows are displayed.

Continued

Setting		Description												
Global Window Operation	Indirect	By specifying the stored address for the Video Module /DVI Unit Window numbers and Display Position, you can change the display position and window number on the device/PLC.												
	Control Word Address	<p>Specifies a window to be displayed or shows/hides the window using the sequence of four Words from the specified address. After storing the display position and the Video Module /DVI Unit Window number you want to view, turn ON bit 0 in the control address to enable the display.</p> <table border="1" style="margin-left: auto; margin-right: auto;"> <tr> <td>+0</td> <td>Control</td> </tr> <tr> <td>+1</td> <td>Window Number</td> </tr> <tr> <td>+2</td> <td>Display Position (X</td> </tr> <tr> <td>+3</td> <td>Coordinate)</td> </tr> <tr> <td></td> <td>Display Position (Y</td> </tr> <tr> <td></td> <td>Coordinate)</td> </tr> </table>	+0	Control	+1	Window Number	+2	Display Position (X	+3	Coordinate)		Display Position (Y		Coordinate)
	+0	Control												
+1	Window Number													
+2	Display Position (X													
+3	Coordinate)													
	Display Position (Y													
	Coordinate)													
Data Type	Select the data format for value, [Bin] or [BCD].													

■ Emulate Touch Output

This allows you to output touch coordinates to a PC using serial communication. To use the PC mouse cursor to emulate touches on the GP, install on the PC mouse emulation software so the PC can receive touch information sent from the GP.

IMPORTANT

- For the touch output, have the following ready.
 - Mouse emulation software manufactured by Digital Electronics Corporation of Japan.
You can download the software from the support site "Otasuke Pro!" (<http://www.pro-face.com/otasuke/>).
 - RGB cable (commercially available)
 - Serial cable, cross (commercially available)

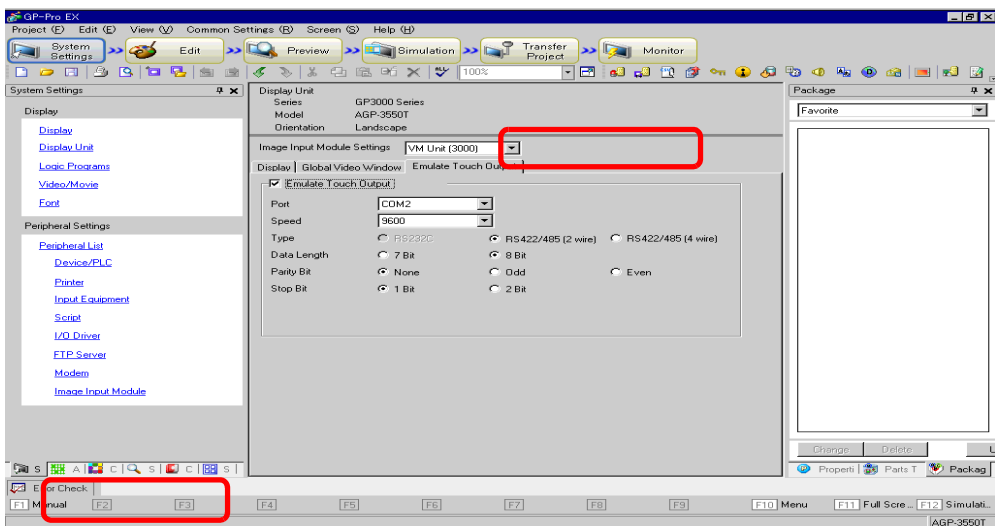

Setting	Description
RGB Emulate Touch Output	Using RGB inputs, select whether or not to output touch coordinates to external devices over serial communication lines.
Port	Select a port for the touch output from either [COM1] or [COM2]. NOTE • When specifying the port Number to be used,  mark ("Duplicate Port") is displayed.
Communication Speed	Select a communication speed from [2400], [4800], [9600], [19200], [38400], [57600] or [115200].
Communication Settings	Select the communication method from [RS232C], [RS422/485 (2 wire)], or [RS422/485 (4 wire)]
Data Length	Select the data length from either [7] or [8].
Parity	Select the parity bit from [None], [Odd], or [Even].
Stop Bit	Select the stop bit from either [1] or [2].

Continued

Setting	Description
Flow Control	Select the flow control from [None], [RTS/CTS], or [ER (DTR/CTS)]. <div style="border: 1px solid black; padding: 2px; display: inline-block; margin: 5px 0;">NOTE</div> <ul style="list-style-type: none"> • When [Port] = [USB-SIO], [Flow Control] is set to [None].

Setup Procedure

- 1 In the system settings window, select the [Emulate Touch Output] check box in the [Image Input Module Setting] to configure the communication settings. Configure the mouse emulation settings on the PC.
- 2 From the [Common Settings] menu select [Image Input Module Window Settings] and create a new screen. Double-click the displayed screen and open the Settings dialog box. Select [Emulate Touch Output] in the [Channel] and select the [Allow Input] check box.
- 3 Draw the Video Module /DVI Unit display on the base screen and set up the window display settings.

Operation Method

Write "1" in the GP internal device address LS9230 to enable touch output. The touch information to be output will be written in LS9231 - LS9233.

LS9230	Allowed/Not allowed	Not allowed, 1: Allowed
LS9231	Touch State	Touch ON 1: Touch OFF
LS9232	X:	0 to 1023
LS9233	Y:	0 to 1023

27.9.7 Image Input Module Display Settings Guide

The Video Module /DVI Unit Display is the part for displaying the Video Window on the screen.

The "Video Module /DVI Unit Window Settings] operates the video with the position and operation settings specified in the [Common Settings] window's [Image Input Module Display].

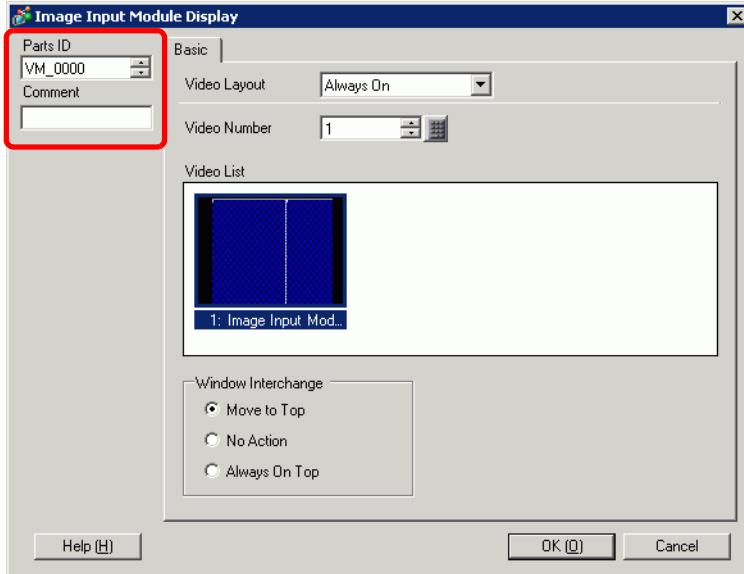

Setting	Description
Part ID	An ID Number is assigned to the parts placed on the screen. Movie Player Part ID: VM_**** (4 digit number) The letter portion is fixed. You can change the number portion within the range of 0000-9999.
Comment	The comment for each Part can be up to 20 characters.

NOTE

- When selecting [DVI Unit] for the [Video Module/ DVI Unit Settings] in the [System Settings] window, a portion of the [Video Module/ DVI Unit Display] items cannot be set. For more details, please refer to the following.
☞ "27.10.3 Restrictions on DVI Unit Features" (page 27-150)

■ Basic

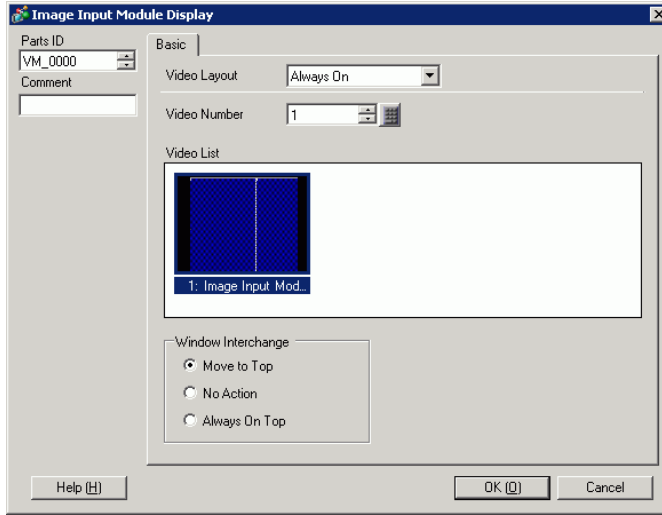

Setting	Description								
Video Layout	Select the display operation for the Image Input Module window.								
Always On	Always displays the Image Input Module window.								
Window On/Off	Displays/hides the window in [Window Display Bit Address].								
Indirect	Use the four consecutive words from the defined [Window Display Word Address] to control which Video Module /DVI to display and to show or hide the display. Use the addresses to define the Video Module /DVI Unit window number and the display coordinates and display the window (by turning ON bit 0 in the control address.) <table border="1" style="margin-left: 40px;"> <tr> <td>+0</td> <td>Control</td> </tr> <tr> <td>+1</td> <td>Window Number</td> </tr> <tr> <td>+2</td> <td>Display coordinate (X)</td> </tr> <tr> <td>+3</td> <td>Display coordinate (Y)</td> </tr> </table>	+0	Control	+1	Window Number	+2	Display coordinate (X)	+3	Display coordinate (Y)
+0	Control								
+1	Window Number								
+2	Display coordinate (X)								
+3	Display coordinate (Y)								
Video Number	Specifies the number of the Video Module /DVI Unit window to display when the [Window Type] is set to [Always On] or [ON/OFF Display]. The setting range is from 0 to 512.								
Window Display Bit Address	When the [Window Type] is set to [Always ON] or [ON/OFF Display], you can specify the video module using thumbnails, or specify the video window from a list.								
Video List	When the [Window Type] is set to [Always ON] or [ON/OFF Display], you can specify the Video Module /DVI using thumbnails. Or you can specify the video window from a list.								
Window Interchange	[Move to Top], [No Action], or [Always On Top]. Available when [Window Type] is set to [Always On] or [ON/OFF Display].								
Window display word address	When you select [Indirect] under [Video Layout], you can specify the displayed Image Input Module window number and display position and control the display/erase of the address.								
Data Type	When you select [Indirect] under [Video Layout], you can specify the data type of value stored in [Window display word address] from [Bin] or [BCD].								

27.10 Restrictions

■ Differences Between Movie and Video Module Features

Items	Movie play feature	Video Module DVI Unit Features
Camera for displaying objects	1-ch camera input with AGP-3*50T Movie file on the CF/FTP server	4-ch camera input on VM Unit RGB input on the image input module
Setup part	Movie Player	Image Input Module Display
Number of simultaneous camera displays	Displays only one image.	The display area can be divided into four areas and the number of images to be displayed can be selected.
Movie recording function	Enable	None
Movie JPEG Capture Feature	None	Enable
Camera input signal format	NTSC/PAL/SECAM	NTSC/PAL

27.10.1 Restrictions on Movie Features

■ Movie Player

- Only one Movie Player can be placed on one Base Screen or Window Screen.
- The width (X coordinate) of the Movie Player can be specified in multiples of four pixels.
- If the size of the Movie Player is smaller than the video input image, part of the area that does not fit the screen will not be displayed. To view the entire image, move the image using the move switch.

For example, AGP-3550T (640 x 480)

The video signal is [NTSC] (640 x 480)

[Size] of Movie Player is [Normal]

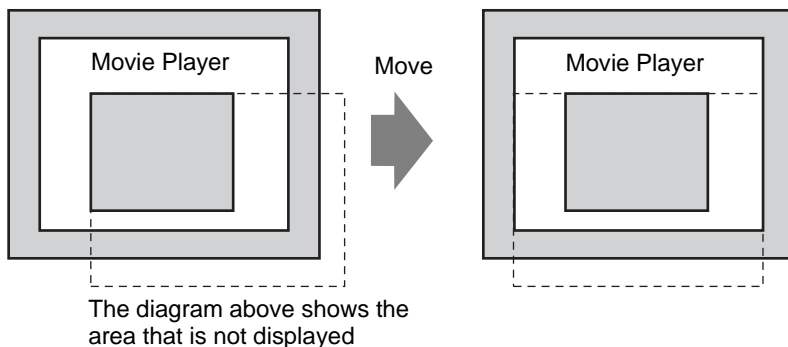

- The following table lists the video signal settings, operable cameras, and movie files.

Video Signal Setting	Video Signal	Movie Player File	Movie Record File
NTSC	NTSC	NTSC	NTSC
PAL	PAL	PAL	PAL
SECAM	SECAM	PAL	PAL

- When returning online after moving to offline mode or transfer mode while a video is being displayed or played, all functions stop. The picture will not be displayed. Touch the video display switch or the play switch to display the video.
- If you record objects moving at high speed, during playback of the video, it may look as if the image stops periodically.

■ Video Display

- There is no sound when displaying real-time video. Video that has been recorded in a movie file will play with sound.
- The video display function can be used simultaneously with the movie recording function for recording on a CF Card or FTP server, but the video display function cannot be used simultaneously with the play function.

■ Recording

- You cannot save another file until one file is saved successfully. You can save the file onto a CF card and FTP server simultaneously.
- It is not possible to play a movie while it is being recorded.
- When the operation of the event recorder function is specified as [Always], the play function cannot be used.
- Record to CF and Record to FTP can be operated simultaneously while using the event recorder function. However, the writing speed slows and saving will take longer to complete.
- The folder or file name in which a movie is recorded cannot be changed during recording.
- If an error occurs during recording, turn ON bit 1 (resume bit) of the specified [Control Address]. The error will be corrected, and bit 1 (save enable bit) of the status address will turn ON. Directly turning ON the save enable bit will not correct the error.
- When starting to save a movie on the CF Card, the number of files in the Save To folder is confirmed. If the predefined number of files have already been saved, it cannot be saved. However, if [Loop] is set to [Auto], an error does not occur. The oldest file is deleted and a new file is saved.
- If the destination folder contains files with any of the following characteristics, you cannot save to the CF card.
 - A file with a name in which the number of characters do not match the specified number.
 - A file with a name in which the first two characters (the user specifiable string) do not match the specified characters.
 - A file with an extension other than ".SDX"
- Do not place a file that was arbitrarily created under the "MOVIE" folder on the CF Card. An error may occur during saving to the CF Card, or the file may be deleted.
- Do not operate a screen configured with a CF Card if the CF Card is not inserted in the GP. It may not work properly.
- The number of times that data can be written on a CF Card is limited. (Approximately 100,000 times for rewriting 500 KB.)
- Up to 32 FTP servers can be registered.
- The number of movie files to be saved on a FTP server differs depending on the specifications of the FTP server.
- If an error is returned from a FTP server, the saving operation will stop.
- The server connection number cannot be changed while a movie is being saved on the FTP server.
- When switching to offline mode or transfer mode during recording, the save function stops and the pictures that have been recorded at that time are saved.

■ Playing a Movie

- You cannot record video while playing a movie.
- When [Play List] is specified as [CF] or [FTP] in Movie Player, Movie Player will not operate if the movie playlist file does not exist. If the playlist file was deleted, use Special Data Display [File Manager] to play the movie.
- Only SDX format movie files can be played.
- While you are playing a video file saved on the FTP server, functions such as pause, fast forward, rewind, slow motion play, or frame-by-frame forward/reverse play cannot be used to change the playback speed. If these operational switches are placed, it will not work.
- You can change file names but that will not affect the play order. Movie files are played in the order in which they were created on the CF card or FTP server.
- While a logic program is running, the video recording or movie may stop. When using video recording or movie playing together with logic, input logic wait (LWA) instructions in the logic program.

■ CF Card Cautions for Use

- When ejecting a CF Card, make sure that the CF Card access LED lamp turns OFF. Otherwise, the data on the CF Card may be damaged.
- When accessing a CF Card, be sure not to power OFF or reset the GP, or eject the CF Card. Create an application screen on which the CF Card cannot be accessed, and on that application screen, you may power OFF or reset the GP, open and close the CF Card cover, and eject the CF Card.
- When inserting a CF Card, check the front and back sides and the connector position of the card. If the CF Card is inserted the wrong way, the data, the CF Card, or the GP may be damaged.
- Use a CF Card manufactured by Digital Electronics Corporation. If a CF Card manufactured by another company is used, the contents of the CF Card may be damaged.
- Please make sure to back up all CF Card data.
- Please refrain from doing the following, as it can result in damage to data and equipment:
 - Bending the CF Card
 - Dropping the CF Card
 - Spilling water on the card
 - Touching the CF Card's connectors directly
 - Disassembling or modifying the CF Card

27.10.2 Restrictions on Video Module Features

- On the AGP-3500T, AGP-3510T, AGP-3550T, and AGP-3560T, you can install either the SGMU Extended Unit or VM Unit, but not both.
- When the Video Module is installed, the GP display colors are reduced to 32K colors.
- The Video Module display cannot be placed on a window.
- Multiple Video Module displays can be placed on a Base Screen.
- However, only one Video Module display can be displayed on the GP screen.
The Video Module can display a JPEG image up to 1024 x 768. If the JPEG image is larger than this, then the image is reduced to 1024 x 768 or to the display size specified of either 1/4, 1/6, or 1/64. For an SVGA model, a display size up to 800 x 600 can be accommodated, for a VGA model, a display size up to 640 x 480 can be accommodated, and for an XGA model, a display size up to 1024 x 768 can be accommodated. If the image size exceeds the screen size, only part of the image that fits on the screen can be displayed.
- Even when calling the Video Module Unit Window set with transparency settings on the Picture Display in which clearing actions are set, the transparency may not work. When the color code is set at 00 - 07, this phenomenon will not occur.
- When the VM/DVI unit display is set to [Always on Top], do not work with the Show CSV display at the same time on the editor. The Show CSV display's editor screen may display below the VM/DVI unit window, hiding the cancel button.

■ Saving JPEGs

- Only one video signal channel can be used for saving JPEG.
- It is not possible to take a capture of the RGB input screen.
- While taking a capture, processing of parts and video display are stopped.
- It takes approximately three to five seconds to take a capture.
<When acquiring display data>
After the data acquisition processing is complete, the screen is turned OFF. A file will not be created on the CF Card.
<When saving to a CF Card>
After saving is complete, the screen is turned OFF. A file is created on the CF Card.
Capturing a screen during DVI window display is not possible. To capture the screen, first hide the DVI window.

27.10.3 Restrictions on DVI Unit Features

- You cannot save in JPG format or display the data in JPG format.
- You cannot capture the video screen.
- When selecting [DVI Unit] in the [Image Input Module Setting] even when the Video Module Unit is installed, video input is invalid. The settings items are not displayed. Also detailed settings for the video signal settings are not displayed.
- If the input screen has a higher resolution than the GP, it will display only a portion of the image. Please adjust the resolution of the PC to match the GP.
- When the video display is set to [Always on Top], do not work with the Show CSV display at the same time on the editor. The Show CSV display's editor screen may display below the VM/DVI unit window, hiding the cancel button.

■ Image Input Module Window Settings

- Because the DVI input screen is always displayed, the spacing is disabled and the window type is fixed to one screen display. Also, in the channel settings, it will be fixed to RGB Input Image.
- The display size will be operated only under normal settings.
- In the DVI Input display, the area to be the background does not exist and so the background color settings are disabled.
- Video capture action is invalid. Also, processes related to JPEGs are disabled.