



Uni-Telway Driver

1	System Configuration.....	3
2	Selection of External Device	9
3	Example of Communication Setting.....	10
4	Setup Items.....	25
5	Cable Diagram	31
6	Supported Device.....	51
7	Device Code and Address Code.....	55
8	Error Messages.....	56

Introduction

This manual describes how to connect the Display and the External Device (target PLC).

In this manual, the connection procedure will be described by following the below sections:

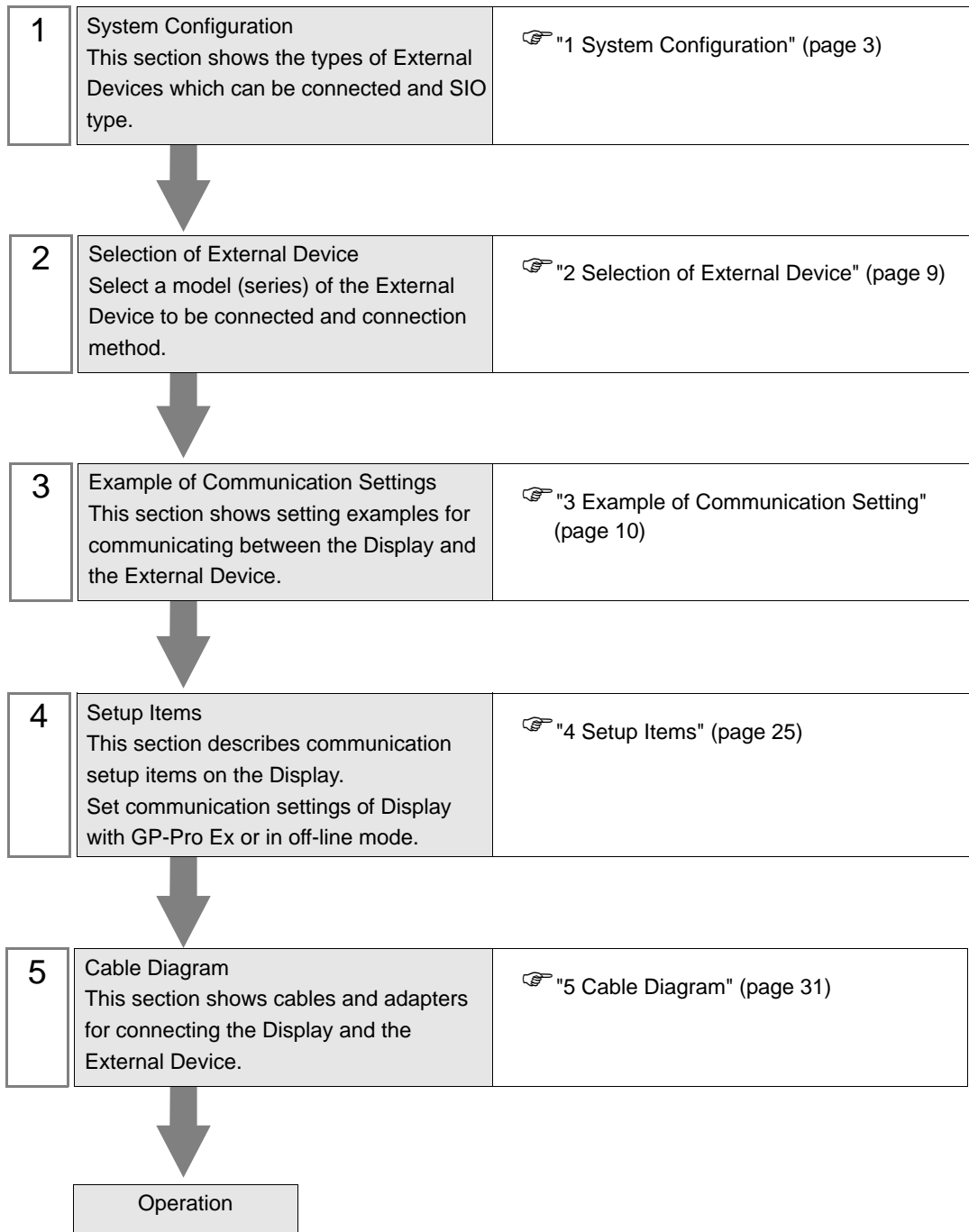

1 System Configuration

The system configuration in the case when the External Device of Schneider Electric Industries and the Display are connected is shown.

Series	CPU	Link I/F	SIO Type	Setting Example	Cable Diagram
Nano	TSX 07 3L □ □ 28 TSX 07 30 10 □ □ TSX 07 31 16 □ □ TSX 07 31 24 □ □ TSX 07 32 □ □ 28 TSX 07 33 □ □ 28	Programming port on CPU	RS232C	Setting Example 1 (page 10)	Cable Diagram 1 (page 31)
			RS422/485 (2wire)	Setting Example 2 (page 13)	Cable Diagram 2 (page 32)
		Accessory box AUX or TER port on TSX P ACC 01	RS422/485 (2wire)	Setting Example 2 (page 13)	Cable Diagram 2 (page 32)
		Accessory box TSX SCA 62	RS422/485 (2wire)	Setting Example 2 (page 13)	Cable Diagram 3 (page 36)
Micro	TSX 37 05 028DR1 TSX 37 08 056DR1 TSX 37 10 128DT1 TSX 37 10 128DR1 TSX 37 10 128DTK1 TSX 37 10 164DTK1 TSX 37 10 028AR1 TSX 37 10 028DR1 TSX 37 21 101 TSX 37 22 101 TSX 37 21 001 TSX 37 22 001	TER port on CPU	RS232C	Setting Example 3 (page 16)	Cable Diagram 1 (page 31)
			RS422/485 (2wire)	Setting Example 4 (page 19)	Cable Diagram 2 (page 32)
		AUX port on CPU	RS422/485 (2wire)	Setting Example 4 (page 19)	Cable Diagram 2 (page 32)
		Accessory box AUX or TER port on TSX P ACC 01	RS422/485 (2wire)	Setting Example 4 (page 19)	Cable Diagram 2 (page 32)
	Accessory box TSX SCA 62	RS422/485 (2wire)	Setting Example 4 (page 19)	Cable Diagram 3 (page 36)	
	TSX 37 21 101 TSX 37 22 101 TSX 37 21 001 TSX 37 22 001	PCMCIA card TSX SCP 114 for RS485	RS422/485 (2wire)	Setting Example 5 (page 22)	Cable Diagram 4 (page 40)
	Premium	TSX P57 103M TSX P57 153M TSX P57 203M TSX P57 253M TSX P57 303M TSX P57 353M TSX P57 453M	TER port on CPU	RS232C	Setting Example 3 (page 16)
RS422/485 (2wire)				Setting Example 4 (page 19)	Cable Diagram 2 (page 32)
AUX port on CPU			RS422/485 (2wire)	Setting Example 4 (page 19)	Cable Diagram 2 (page 32)
Accessory box AUX or TER port on TSX P ACC 01			RS422/485 (2wire)	Setting Example 4 (page 19)	Cable Diagram 2 (page 32)
Accessory box TSX SCA 62			RS422/485 (2wire)	Setting Example 4 (page 19)	Cable Diagram 3 (page 36)
PCMCIA card TSX SCP 114 for RS485			RS422/485 (2wire)	Setting Example 5 (page 22)	Cable Diagram 4 (page 40)
Communication Module TSX SCY 21601 for RS485			RS422/485 (2wire)	Setting Example 4 (page 19)	Cable Diagram 5 (page 47)

■ Connection Configuration

◆ Nano Series

- 1:1 Connection

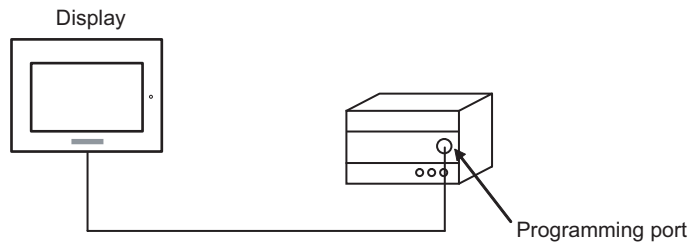

- n:1 Connection

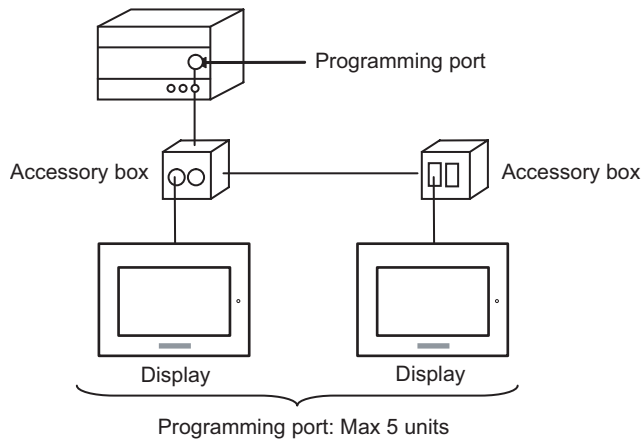

◆ Micro Series

- 1:1 Connection

You can connect the display to TER port, AUX port or PCMCIA card. Simultaneous connection is also available.

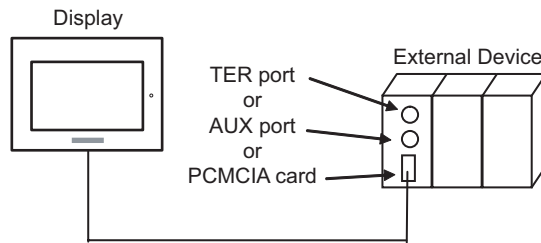

- n:1 Connection (when using accessory box)

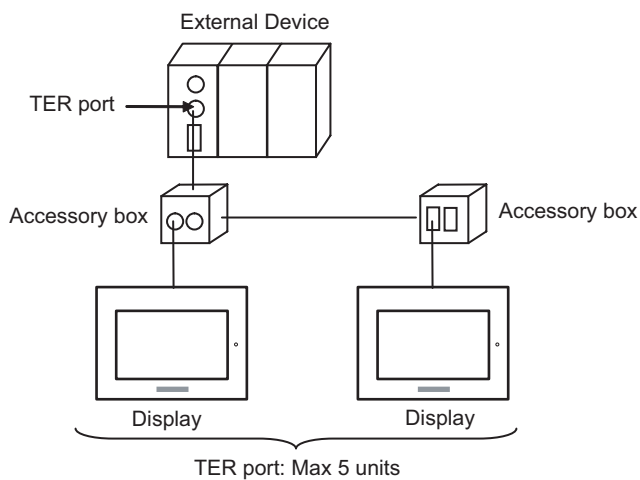

- n:1 Connection (when using PCMCIA card for RS485)

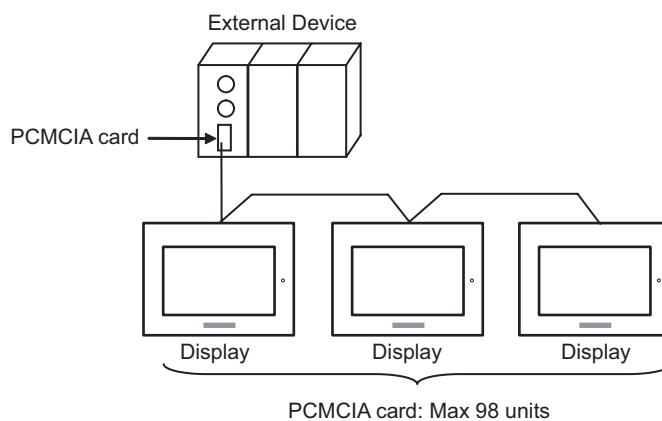

◆ Premium Series

- 1:1 Connection

You can connect the display to TER port, AUX port, PCMCIA card or communication module. Simultaneous connection is also available.

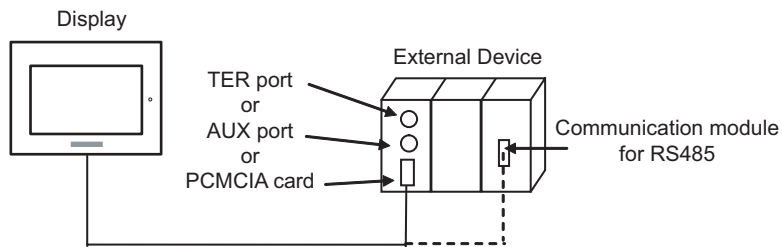

- n:1 Connection (when using accessory box)

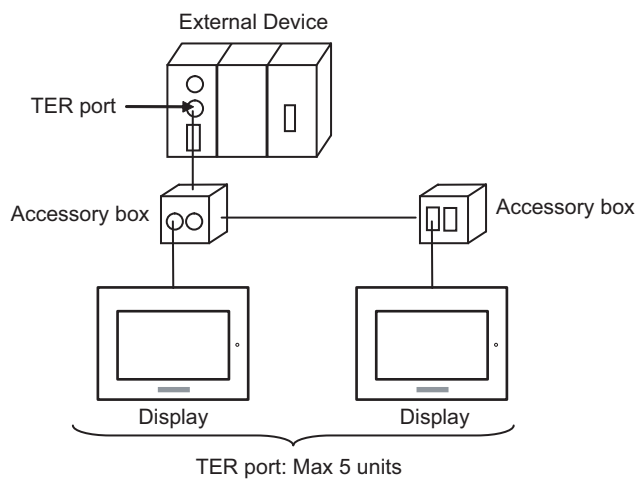

- n:1 Connection (when using PCMCIA card for RS485)

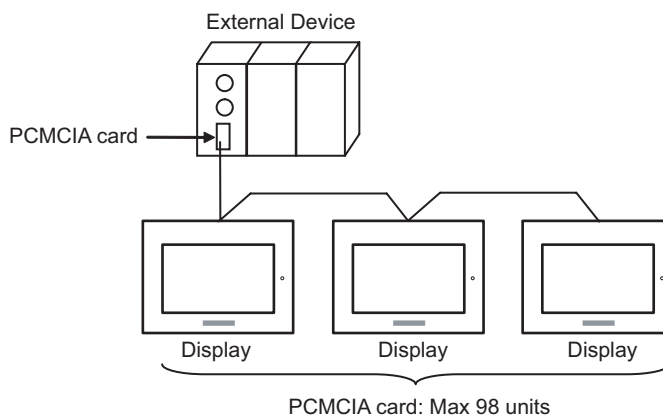

■ COM Port of IPC

When connecting IPC with External Device, the COM port which can be used changes with series and SIO type. Please refer to the manual of IPC for details.

Usable port

Series	Usable port		
	RS-232C	RS-422/485(4 wire)	RS-422/485(2 wire)
PS-2000B	COM1 ^{*1} , COM2, COM3 ^{*1} , COM4	-	-
PS-3450A, PS-3451A	COM1, COM2 ^{*1*2}	COM2 ^{*1*2}	COM2 ^{*1*2}
PS-3650A, PS-3651A	COM1 ^{*1}	-	-
PS-3700A (Pentium®4-M) PS-3710A	COM1 ^{*1} , COM2 ^{*1} , COM3 ^{*2} , COM4	COM3 ^{*2}	COM3 ^{*2}
PS-3711A	COM1 ^{*1} , COM2 ^{*2}	COM2 ^{*2}	COM2 ^{*2}
PL-3000B	COM1 ^{*1*2} , COM2 ^{*1} , COM3, COM4	COM1 ^{*1*2}	COM1 ^{*1*2}

*1 The RI/5V can be switched. Please switch with the change switch of IPC.

*2 It is necessary to set up the SIO type with the Dip switch. Please set up as follows according to SIO type to be used.

Dip switch setting: RS-232C

Dip switch	Setting	Description
1	OFF ^{*1}	Reserve (always OFF)
2	OFF	SIO type: RS-232C
3	OFF	
4	OFF	Output mode of SD (TXD) data: Always output
5	OFF	Terminal resistance (220Ω) insertion to SD (TXD): None
6	OFF	Terminal resistance (220Ω) insertion to RD (RXD): None
7	OFF	Short-circuit of SDA (TXA) and RDA (RXA): Does not Exist
8	OFF	Short-circuit of SDB (TXB) and RDB (RXB): Does not Exist
9	OFF	RS (RTS) Auto control mode: Disable
10	OFF	

*1 It is necessary to turn ON the set value, only when using PS-3450A and PS-3451A.

Dip switch setting: RS-422/485 (4 wire)

Dip switch	Setting	Description
1	OFF	Reserve (always OFF)
2	ON	SIO type: RS-422/485
3	ON	
4	OFF	Output mode of SD (TXD) data: Always output
5	OFF	Terminal resistance (220Ω) insertion to SD (TXD): None
6	OFF	Terminal resistance (220Ω) insertion to RD (RXD): None
7	OFF	Short-circuit of SDA (TXA) and RDA (RXA): Does not Exist
8	OFF	Short-circuit of SDB (TXB) and RDB (RXB): Does not Exist
9	OFF	RS (RTS) Auto control mode: Disable
10	OFF	

Dip switch setting: RS-422/485 (2 wire)

Dip switch	Setting	Description
1	OFF	Reserve (always OFF)
2	ON	SIO type: RS-422/485
3	ON	
4	OFF	Output mode of SD (TXD) data: Always output
5	OFF	Terminal resistance (220Ω) insertion to SD (TXD): None
6	OFF	Terminal resistance (220Ω) insertion to RD (RXD): None
7	ON	Short-circuit of SDA (TXA) and RDA (RXA): Exist
8	ON	Short-circuit of SDB (TXB) and RDB (RXB): Exist
9	ON	RS (RTS) Auto control mode: Enable
10	ON	

2 Selection of External Device

Select the External Device to be connected to the Display.

Setup Items	Setup Description
Maker	Select the maker of the External Device to be connected. Select "Schneider Electric Industries".
Driver	Select a model (series) of the External Device to be connected and connection method. Select "Uni-Telway". Check the External Device which can be connected in "Uni-Telway" in system configuration. ☞ "1 System Configuration" (page 3)
Use System Area	Check this option when you synchronize the system data area of Display and the device (memory) of External Device. When synchronized, you can use the ladder program of External Device to switch the display or display the window on the display. Cf. GP-Pro EX Reference Manual "Appendix 1.4 LS Area (Direct Access Method)" This can be also set with GP-Pro EX or in off-line mode of Display. Cf. GP-Pro EX Reference Manual " 5.17.6 Setting Guide of [System Setting Window]■[Main Unit Settings] Settings Guide◆System Area Setting" Cf. Maintenance/Troubleshooting "2.15.1 Settings common to all Display models◆System Area Settings"
Port	Select the Display port to be connected to the External Device.

3 Example of Communication Setting

Examples of communication settings of the Display and the External Device, recommended by Pro-face, are shown.

3.1 Setting Example 1

■ Setting of GP-Pro EX

◆ Communication Settings

To display the setting screen, select [Device/PLC Settings] from [System setting window] in workspace.

Device/PLC 1

Summary [Change Device/PLC](#)

Maker Series Port

Text Data Mode [Change](#)

Communication Settings

RS232C
 RS422/485(2wire)
 RS422/485(4wire)

Speed

Data Length 7 8

Parity NONE EVEN ODD

Stop Bit 1 2

Flow Control NONE ER(DTR/CTS) XON/XOFF

Timeout (sec)

Client Address

No. of Consecutive Address

RI / VCC
 VCC

In the case of RS232C, you can select the 9th pin to RI (Input) or VCC (5V Power Supply). If you use the Digital's RS232C Isolation Unit, please select it to VCC.

Device-Specific Settings

Allowable No. of Device/PLCs: 16 Unit(s)

No.	Device Name	Settings
1	PLC1	Network=0,Station=254,Gate=0,Selector=0,Connection Pt. / Module=254,Re

◆ Device Setting

To display the setting screen, click  ([Setting]) of External Device you want to set from [Device-Specific Settings] of [Device/PLC Settings].

When [Allowable No. of Device/PLCs] is multiple, you can click  from [Device-Specific Settings] of [Device/PLC Settings] to add External Device which is available to set.

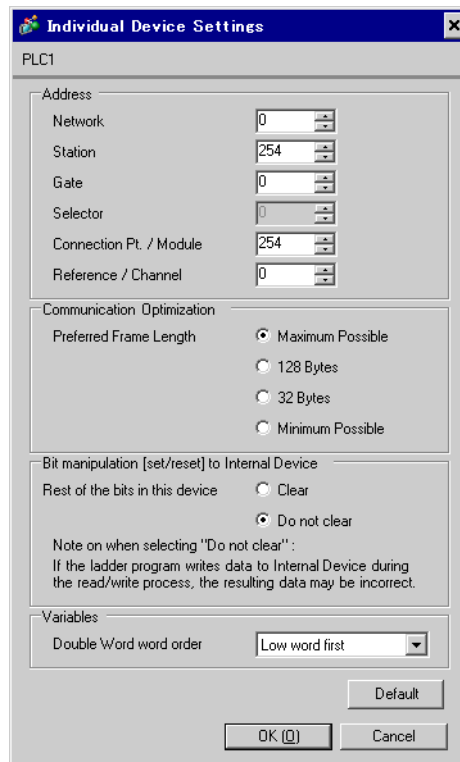

Individual Device Settings

PLC1

Address

Network: 0

Station: 254

Gate: 0

Selector: 0

Connection Pt. / Module: 254

Reference / Channel: 0

Communication Optimization

Preferred Frame Length: Maximum Possible
 128 Bytes
 32 Bytes
 Minimum Possible

Bit manipulation [set/reset] to Internal Device

Rest of the bits in this device: Clear
 Do not clear

Note on when selecting "Do not clear":
 If the ladder program writes data to Internal Device during the read/write process, the resulting data may be incorrect.

Variables

Double Word word order: Low word first

Default

OK (O) Cancel

■ Setting of External Device

Use the ladder software "PL7-07" for communication settings on External Device.

Select [Programming Port] from [Configuration] in PL7-07 and perform the communication settings as below.

Setup Items	Setup Description
Type	UNI-TELWAY Master
Bit/sec	19200
DateBits	8 bits
ParityOdd	Odd
Stop Bits	1 bit
Number of Slaves	8

◆ Notes

- Do not set the address which exceeds "Number of Slaves" on External Device in Server Address and Clients Address. If you set the address which exceeds "Number of Slaves" in Server Address and Clients Address, timeout error will occur, which disables the communication with the External Device. In addition, when you connect many client devices (Display/External Device) on the same serial network, set the longer timeout on the Display.

3.2 Setting Example 2

■ Setting of GP-Pro EX

◆ Communication Settings

To display the setting screen, select [Device/PLC Settings] from [System setting window] in workspace.

Device/PLC 1

Summary [Change Device/PLC](#)

Maker Series Port

Text Data Mode [Change](#)

Communication Settings

SIO Type RS232C RS422/485(2wire) RS422/485(4wire)

Speed

Data Length 7 8

Parity NONE EVEN ODD

Stop Bit 1 2

Flow Control NONE ER(DTR/CTS) XON/XOFF

Timeout (sec)

Client Address

No. of Consecutive Address

RI / VCC RI VCC

In the case of RS232C, you can select the 9th pin to RI (Input) or VCC (5V Power Supply). If you use the Digital's RS232C Isolation Unit, please select it to VCC.

Device-Specific Settings

Allowable No. of Device/PLCs 16 Unit(s)

No.	Device Name	Settings
1	PLC1	Network=0,Station=254,Gate=0,Selector=0,Connection Pt. / Module=254,Re

◆ Device Setting

To display the setting screen, click  ([Setting]) of External Device you want to set from [Device-Specific Settings] of [Device/PLC Settings].

When [Allowable No. of Device/PLCs] is multiple, you can click  from [Device-Specific Settings] of [Device/PLC Settings] to add External Device which is available to set.

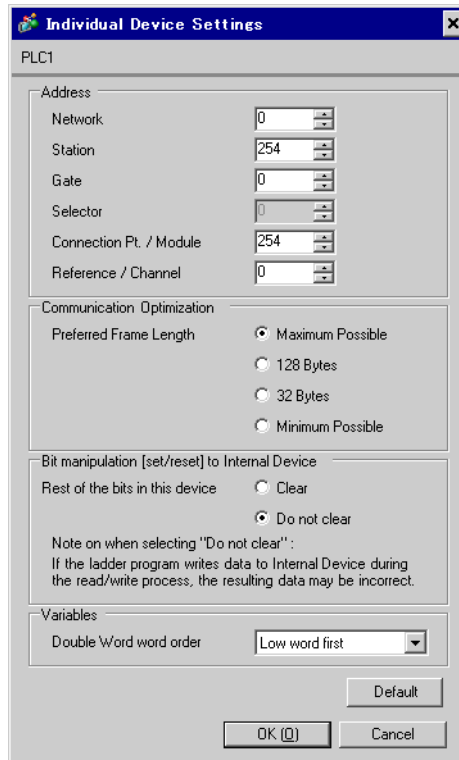

Individual Device Settings

PLC1

Address

Network: 0

Station: 254

Gate: 0

Selector: 0

Connection Pt. / Module: 254

Reference / Channel: 0

Communication Optimization

Preferred Frame Length: Maximum Possible
 128 Bytes
 32 Bytes
 Minimum Possible

Bit manipulation [set/reset] to Internal Device

Rest of the bits in this device: Clear
 Do not clear

Note on when selecting "Do not clear":
 If the ladder program writes data to Internal Device during the read/write process, the resulting data may be incorrect.

Variables

Double Word word order: Low word first

Default

OK (O) Cancel

■ Setting of External Device

Use the ladder software "PL7-07" for communication settings on External Device.

Select [Programming Port] from [Configuration] in PL7-07 and perform the communication settings as below.

Setup Items	Setup Description
Type	UNI-TELWAY Master
Bit/sec	19200
DateBits	8 bits
ParityOdd	Odd
Stop Bits	1 bit
Number of Slaves	8

◆ Notes

- Do not set the address which exceeds "Number of Slaves" on External Device in Server Address and Clients Address. If you set the address which exceeds "Number of Slaves" in Server Address and Clients Address, timeout error will occur, which disables the communication with the External Device. In addition, when you connect many client devices (Display/External Device) on the same serial network, set the longer timeout on the Display.

3.3 Setting Example 3

■ Setting of GP-Pro EX

◆ Communication Settings

To display the setting screen, select [Device/PLC Settings] from [System setting window] in workspace.

Device/PLC 1

Summary [Change Device/PLC](#)

Maker Series Port

Text Data Mode [Change](#)

Communication Settings

SID Type RS232C RS422/485(2wire) RS422/485(4wire)

Speed

Data Length 7 8

Parity NONE EVEN ODD

Stop Bit 1 2

Flow Control NONE ER(DTR/CTS) XON/XOFF

Timeout (sec)

Client Address

No. of Consecutive Address

RI / VCC RI VCC

In the case of RS232C, you can select the 9th pin to RI (Input) or VCC (5V Power Supply). If you use the Digital's RS232C Isolation Unit, please select it to VCC.

Device-Specific Settings

Allowable No. of Device/PLCs: 16 Unit(s)

No.	Device Name	Settings
1	PLC1	Network=0,Station=254,Gate=0,Selector=0,Connection Pt. / Module=254,Re

◆ Device Setting

To display the setting screen, click  ([Setting]) of External Device you want to set from [Device-Specific Settings] of [Device/PLC Settings].

When [Allowable No. of Device/PLCs] is multiple, you can click  from [Device-Specific Settings] of [Device/PLC Settings] to add External Device which is available to set.

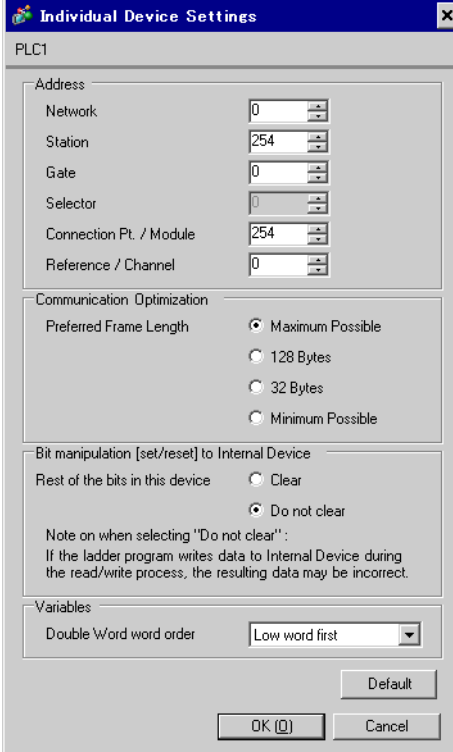

Individual Device Settings

PLC1

Address

Network: 0

Station: 254

Gate: 0

Selector: 0

Connection Pt. / Module: 254

Reference / Channel: 0

Communication Optimization

Preferred Frame Length

Maximum Possible

128 Bytes

32 Bytes

Minimum Possible

Bit manipulation [set/reset] to Internal Device

Rest of the bits in this device

Clear

Do not clear

Note on when selecting "Do not clear":
If the ladder program writes data to Internal Device during the read/write process, the resulting data may be incorrect.

Variables

Double Word word order: Low word first

Default

OK (O) Cancel

■ Setting of External Device

Use the ladder software "PL7-07" for communication settings on External Device.

Go to [Configuration] in [Application Browser], [Hardware Configuration] and [Comm] in this order in "PL7-07", and perform the communication settings as below.

Setup Items	Setup Description
CHANNEL	CHANNEL 0
	UNI-TELWAY LINK
Type	Master
Trasmission Speed	19200
Data	8 bits
Parity	Odd
Stop	1 bit
Number of Slaves	8

◆ Notes

- Do not set the address which exceeds "Number of Slaves" on External Device in Server Address and Clients Address. If you set the address which exceeds "Number of Slaves" in Server Address and Clients Address, timeout error will occur, which disables the communication with the External Device. In addition, when you connect many client devices (Display/External Device) on the same serial network, set the longer timeout on the Display.

3.4 Setting Example 4

■ Setting of GP-Pro EX

◆ Communication Settings

To display the setting screen, select [Device/PLC Settings] from [System setting window] in workspace.

Device/PLC 1

Summary [Change Device/PLC](#)

Maker Series Port

Text Data Mode [Change](#)

Communication Settings

RS232C
 RS422/485(2wire)
 RS422/485(4wire)

Speed

Data Length 7 8

Parity NONE EVEN ODD

Stop Bit 1 2

Flow Control NONE ER(DTR/CTS) XON/XOFF

Timeout (sec)

Client Address

No. of Consecutive Address

RI VDC

In the case of RS232C, you can select the 9th pin to RI (Input) or VDC (5V Power Supply). If you use the Digital's RS232C Isolation Unit, please select it to VDC.

[Default](#)

Device-Specific Settings

Allowable No. of Device/PLCs 16 Unit(s)

No.	Device Name	Settings
1	PLC1	Network=0,Station=254,Gate=0,Selector=0,Connection Pt. / Module=254,Re

◆ Device Setting

To display the setting screen, click  ([Setting]) of External Device you want to set from [Device-Specific Settings] of [Device/PLC Settings].

When [Allowable No. of Device/PLCs] is multiple, you can click  from [Device-Specific Settings] of [Device/PLC Settings] to add External Device which is available to set.

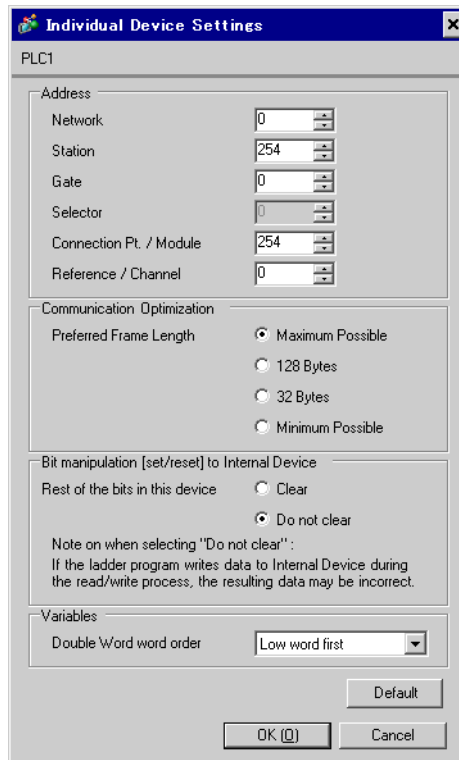

Individual Device Settings [X]

PLC1

Address

Network: 0

Station: 254

Gate: 0

Selector: 0

Connection Pt. / Module: 254

Reference / Channel: 0

Communication Optimization

Preferred Frame Length: Maximum Possible
 128 Bytes
 32 Bytes
 Minimum Possible

Bit manipulation [set/reset] to Internal Device

Rest of the bits in this device: Clear
 Do not clear

Note on when selecting "Do not clear":
 If the ladder program writes data to Internal Device during the read/write process, the resulting data may be incorrect.

Variables

Double Word word order: Low word first

Default

OK (O) Cancel

■ Setting of External Device

Use the ladder software "PL7-07" for communication settings on External Device.

Go to [Configuration] in [Application Browser], [Hardware Configuration] and [Comm] in this order in "PL7-07", and perform the communication settings as below.

Setup Items	Setup Description
CHANNEL	CHANNEL 0
	UNI-TELWAY LINK
Type	Master
Trasmission Speed	19200
Data	8 bits
Parity	Odd
Stop	1 bit
Number of Slaves	8

◆ Notes

- Do not set the address which exceeds "Number of Slaves" on External Device in Server Address and Clients Address. If you set the address which exceeds "Number of Slaves" in Server Address and Clients Address, timeout error will occur, which disables the communication with the External Device. In addition, when you connect many client devices (Display/External Device) on the same serial network, set the longer timeout on the Display.

3.5 Setting Example 5

■ Setting of GP-Pro EX

◆ Communication Settings

To display the setting screen, select [Device/PLC Settings] from [System setting window] in workspace.

Device/PLC 1

Summary [Change Device/PLC](#)

Maker Series Port

Text Data Mode [Change](#)

Communication Settings

SIQ Type RS232C RS422/485(2wire) RS422/485(4wire)

Speed

Data Length 7 8

Parity NONE EVEN ODD

Stop Bit 1 2

Flow Control NONE ER(DTR/CTS) XON/XOFF

Timeout (sec)

Client Address

No. of Consecutive Address

RI / VCC RI VCC

In the case of RS232C, you can select the 9th pin to RI (Input) or VCC (5V Power Supply). If you use the Digital's RS232C Isolation Unit, please select it to VCC.

Device-Specific Settings

Allowable No. of Device/PLCs: 16 Unit(s)

No.	Device Name	Settings
1	PLC1	Network=0,Station=254,Gate=0,Selector=0,Connection Pt. / Module=254,Re

◆ Device Setting

To display the setting screen, click  ([Setting]) of External Device you want to set from [Device-Specific Settings] of [Device/PLC Settings].

When [Allowable No. of Device/PLCs] is multiple, you can click  from [Device-Specific Settings] of [Device/PLC Settings] to add External Device which is available to set.

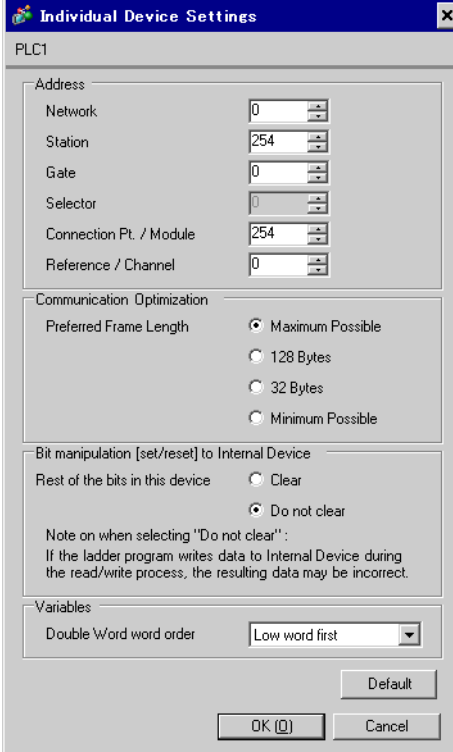

Individual Device Settings

PLC1

Address

Network: 0

Station: 254

Gate: 0

Selector: 0

Connection Pt. / Module: 254

Reference / Channel: 0

Communication Optimization

Preferred Frame Length

Maximum Possible

128 Bytes

32 Bytes

Minimum Possible

Bit manipulation [set/reset] to Internal Device

Rest of the bits in this device

Clear

Do not clear

Note on when selecting "Do not clear":

If the ladder program writes data to Internal Device during the read/write process, the resulting data may be incorrect.

Variables

Double Word word order: Low word first

Default

OK (O) Cancel

■ Setting of External Device

Use the ladder software "PL7-07" for communication settings on External Device.

Go to [Configuration] in [Application Browser], [Hardware Configuration] and [Comm] in this order in "PL7-07", and perform the communication settings as below.

Setup Items	Setup Description
CHANNEL	CHANNEL 1
	TSX SCP 114 RS485 MP PCMCIA CARD
	UNI-TELWAY LINK
Type	Master
Trasmission Speed	19200
Data	8 bits
Parity	Odd
Stop	1 bit
Number of Slaves	8

◆ Notes

- Do not set the address which exceeds "Number of Slaves" on External Device in Server Address and Clients Address. If you set the address which exceeds "Number of Slaves" in Server Address and Clients Address, timeout error will occur, which disables the communication with the External Device. In addition, when you connect many client devices (Display/External Device) on the same serial network, set the longer timeout on the Display.

4 Setup Items

Set communication settings of Display with GP-Pro EX or in off-line mode of Display.

The setting of each parameter must be identical to that of External Device.

 "3 Example of Communication Setting" (page 10)

4.1 Setup Items in GP-Pro EX

■ Communication Settings

To display the setting screen, select [Device/PLC Settings] from [System setting window] in workspace.

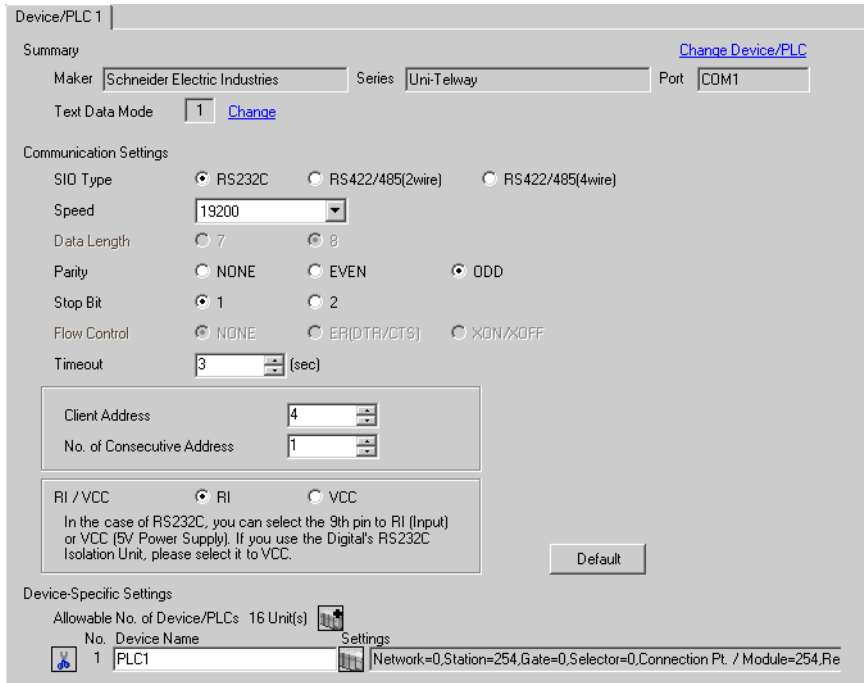

Setup Items	Setup Description
SIO Type	Select the SIO type to communicate with the External Device.
Speed	Select speed between the External Device and the Display.
Data Length	Display data length.
Parity	Select how to check parity.
Stop Bit	Select stop bit length.
Flow Control	Display the communication control method to prevent overflow of transmission and reception data.
Timeout	Use an integer from 1 to 127 to enter the time (s) for which the Display waits for the response from the External Device.
Client Address	Use an integer from 1 to 98 to enter the client address (source address).
No. of Consecutive Address ^{*1}	Use an integer 1 to 5 to enter the No. of consecutive address.
RI/VCC	You can switch RI/VCC of the 9th pin when you select RS232C for SIO type. It is necessary to change RI/5V by changeover switch of IPC when connect with IPC. Please refer to the manual of the IPC for more detail.

- *1 Set the value of "Client address + Consecutive address number - 1" to 98 or less. Address which exceeds 98 is not used because it is not polled from the master.

■ Device Setting

To display the setting screen, click  ([Setting]) of External Device you want to set from [Device-Specific Settings] of [Device/PLC Settings].

When [Allowable No. of Device/PLCs] is multiple, you can click  from [Device-Specific Settings] of [Device/PLC Settings] to add External Device which is available to set.

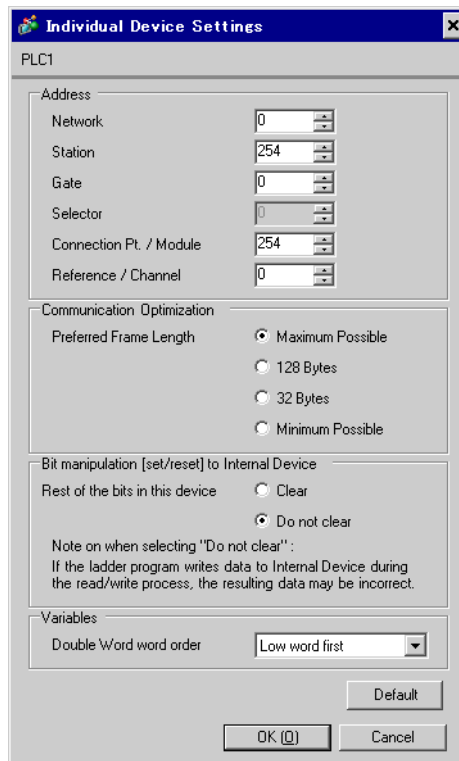

Setup Items	Setup Description
Network	Enter the Network No. of the destination External Device.
Station	Enter the station No. in the network.
Gate	Enter the gate No. in the network.
Selector	Enter the connected communication channel. This item becomes available only when the gate value is "8."
Connection Pt./Module	Enter the connection point in case of Level 6 Addressing, and enter the module number in case of Level 5 Addressing.
Reference/Channel	Enter the reference in case of Level 6 Addressing, and enter the channel in case of Level 5 Addressing.
Preferred Frame Length	Specify the frame length.
Rest of the bits in this device	From "Clear" or "Do not clear", select treatment of the rest of the bits in the same word when the bit manipulation to Internal Device is performed.
Double Word word order ^{*1}	Specify the word order when displaying the 16-bit device in 32-bit.

- *1 When you change the word order, set all devices in the screen data again.

4.2 Setup Items in Off-Line Mode

- NOTE** • Refer to the Maintenance/Troubleshooting manual for information on how to enter off-line mode or about the operation.

Cf. Maintenance/Troubleshooting Manual "2.2 Off-line Mode"

■ Communication Settings

To display the setting screen, touch [Device/PLC Settings] from [Peripheral Settings] in off-line mode. Touch the External Device you want to set from the displayed list.

Comm.	Device	Option		
Uni-Telway			[COM1]	Page 1/1
SIO Type		RS232C		
Speed		19200		
Data Length		8		
Parity		<input type="radio"/> NONE <input type="radio"/> EVEN <input checked="" type="radio"/> ODD		
Stop Bit		<input checked="" type="radio"/> 1 <input type="radio"/> 2		
Flow Control		NONE		
Timeout(s)		3		
Client Address		4		
No. of Consecutive		1		
	Exit		Back	2006/04/12 14:53:43

Setup Items	Setup Description
SIO Type	Select the SIO type to communicate with the External Device. IMPORTANT To make the communication settings correctly, confirm the serial interface specifications of Display unit for [SIO Type]. We cannot guarantee the operation if a communication type that the serial interface does not support is specified. For details concerning the serial interface specifications, refer to the manual for Display unit.
Speed	Select speed between the External Device and the Display.
Data Length	Display data length.
Parity	Select how to check parity.
Stop Bit	Select stop bit length.
Flow Control	Display the communication control method to prevent overflow of transmission and reception data.
Timeout	Use an integer from 1 to 127 to enter the time (s) for which the Display waits for the response from the External Device.
Client Address	Use an integer from 1 to 98 to enter the client address (source address).
No. of Consecutive*1	Use an integer 1 to 5 to enter the No. of consecutive address.

- *1 Set the value of "Client address + Consecutive address number - 1" to 98 or less. Address which exceeds 98 is not used because it is not polled from the master.

■ Device Setting

To display the setting screen, touch [Device/PLC Settings] from [Peripheral Settings]. Touch the External Device you want to set from the displayed list, and touch [Device].

Comm.	Device	Option		
Uni-Telway			[COM1]	Page 1/1
Device/PLC Name [PLC1] ▼				
Network			0 ▼ ▲	
Station			254 ▼ ▲	
Gate			0 ▼ ▲	
Selector			0 ▼ ▲	
Connection Pt./Module			254 ▼ ▲	
Reference/Channel			0 ▼ ▲	
Frame Length			Maximum Possible ▼	
Bit manipulation to Internal Device				
Rest of bits in word are not cleared				
Double Word word order Low word first				
Exit		Back		2006/04/12 14:53:45

Setup Items	Setup Description
Device/PLC Name	Select the External Device for device setting. Device name is a title of External Device set with GP-Pro EX.(Initial value [PLC1])
Network	Enter the Network No. of the destination External Device.
Station	Enter the station No. in the network.
Gate	Enter the gate No. in the network.
Selector	Enter the connected communication channel. This item becomes available only when the gate value is "8."
Connection Pt./Module	Enter the connection point in case of Level 6 Addressing, and enter the module number in case of Level 5 Addressing.
Reference/Channel	Enter the reference in case of Level 6 Addressing, and enter the channel in case of Level 5 Addressing.
Frame Length	Specify the frame length.
Bit manipulation to Internal Device	From "Rest of bits in word are cleared" or "Rest of bits in word are not cleared", display treatment of the rest of the bits in the same word when the bit manipulation to Internal Device is performed. (Not available to set in off-line mode.)
Double Word word order	The word order when displaying the 16-bit device in 32-bit is displayed. You cannot change the word order in [Device Setting] in off-line mode.

■ Option

To display the setting screen, touch [Device/PLC Settings] from [Peripheral Settings]. Touch the External Device you want to set from the displayed list, and touch [Option].

Comm.	Device	Option		
Uni-Telway			[COM1]	Page 1/1
RI / VCC ● RI ● VCC In the case of RS232C, you can select the 9th pin to RI(Input) or VCC(5V Power Supply). If you use the Digital's RS232C Isolation Unit, please select it to VCC.				
	Exit		Back	2006/04/12 14:53:48

Setup Items	Setup Description
RI/VCC	You can switch RI/VCC of the 9th pin when you select RS232C for SIO type. It is necessary to change RI/5V by changeover switch of IPC when connect with IPC. Please refer to the manual of the IPC for more detail.

5 Cable Diagram

The cable diagram shown below may be different from the cable diagram recommended by Schneider Electric Industries. Please be assured there is no operational problem in applying the cable diagram shown in this manual.

- The FG pin of the main body of External Device must be D-class grounded. Please refer to the manual of External Device for more details.
- SG and FG are connected inside Display. When connecting SG to External Device, design the system not to form short-circuit loop.
- Connect the isolation unit, when communication is not stabilized under the influence of a noise etc..

Cable Diagram 1

Display (Connection Port)	Cable	Notes
GP (COM1) ST (COM1) IPC* ¹ PC/AT	Cable by Schneider Electric Industries TSX PCX 1031 (2.5m)	

*1 Only the COM port which can communicate by RS-232C can be used.

 ■ COM Port of IPC (page 7)

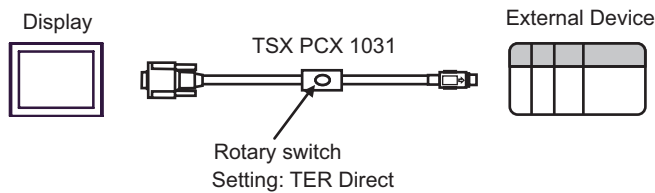

Cable Diagram 2

Display (Connection Port)	Cable		Notes
GP* ¹ (COM1) AGP-3302B (COM2) ST* ² (COM2)	A	COM port conversion adapter by Pro-face CA3-ADPCOM-01 + Terminal block conversion adapter by Pro-face CA3-ADPTRM-01 + Your own cable	The cable length must be 10m or less.
	B	Your own cable	
GP* ³ (COM2)	C	Online adapter by Pro-face CA4-ADPONL-01 + Terminal block conversion adapter by Pro-face CA3-ADPTRM-01 + Your own cable	
	D	Online adapter by Pro-face CA4-ADPONL-01 + Your own cable	
IPC* ⁴	E	COM port conversion adapter by Pro-face CA3-ADPCOM-01 + Terminal block conversion adapter by Pro-face CA3-ADPTRM-01 + Your own cable	
	F	Your own cable	

*1 All GP models except AGP-3302B

*2 All ST models except AST-3211A

*3 All GP models except GP-3200 series and AGP-3302B

*4 Only the COM port which can communicate by RS-422/485 (2 wire) can be used.

 ■ COM Port of IPC (page 7)

A) When using the COM port conversion adapter (CA3-ADPCOM-01), the connector terminal block conversion adapter (CA3-ADPTRM-01) by Pro-face and your own cable

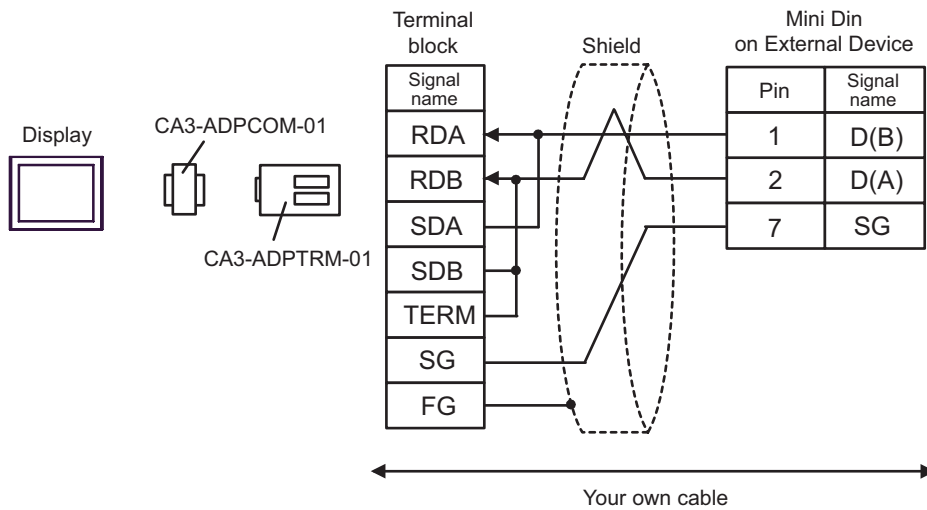

B) When using your own cable

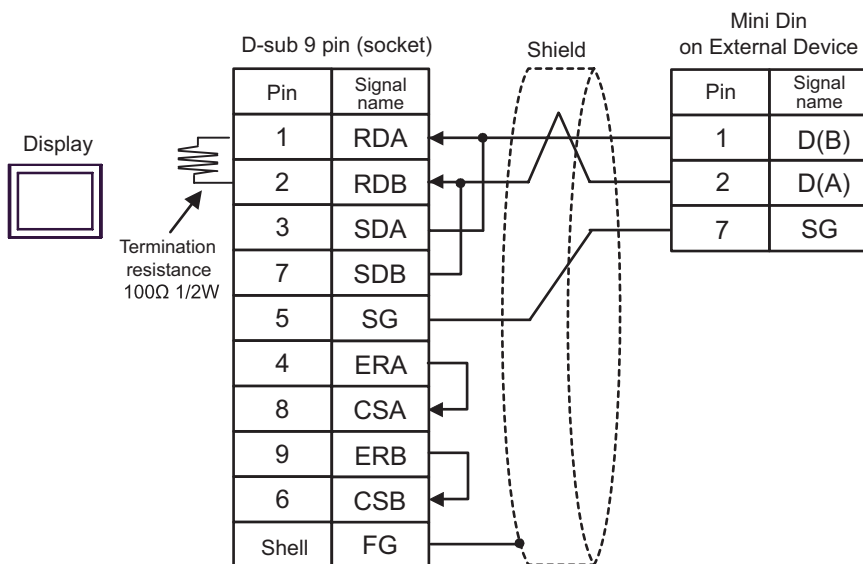

C) When using the online adapter (CA4-ADPONL-01), the connector terminal block conversion adapter (CA3-ADPTRM-01) by Pro-face and your own cable

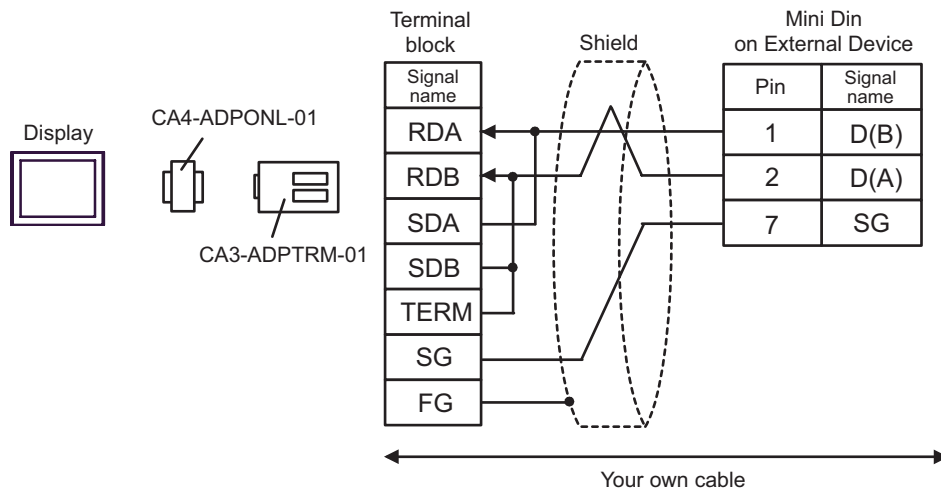

D) When using the online adapter (CA4-ADPONL-01) by Pro-face and your own cable

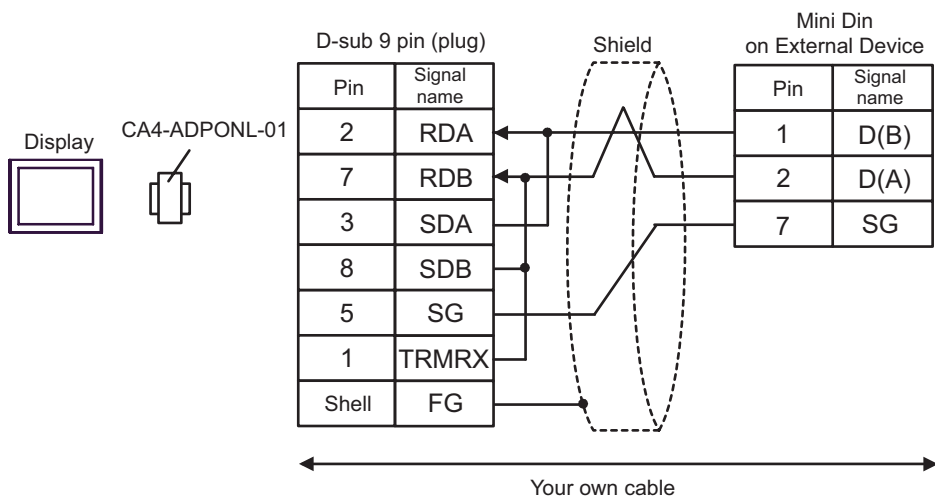

E) When using the COM port conversion adapter (CA3-ADPCOM-01), the connector terminal block conversion adapter (CA3-ADPTRM-01) by Pro-face and your own cable

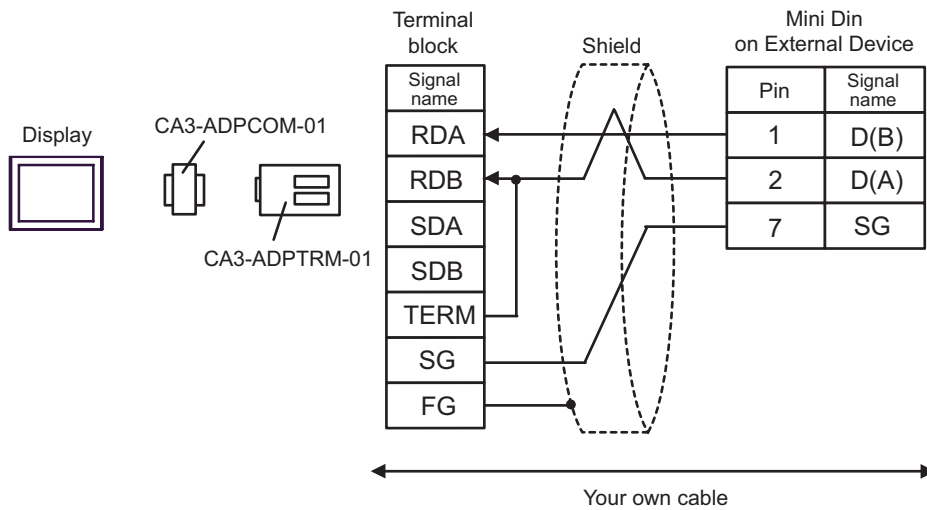

F) When using your own cable

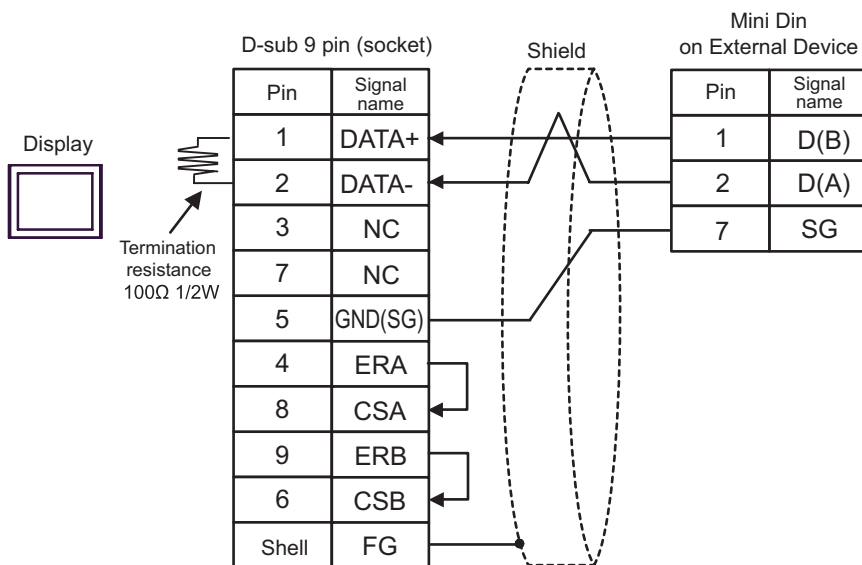

Cable Diagram 3

Display (Connection Port)	Cable		Notes
GP* ¹ (COM1) AGP-3302B (COM2) ST* ² (COM2)	A	COM port conversion adapter by Pro-face CA3-ADPCOM-01 + Terminal block conversion adapter by Pro-face CA3-ADPTRM-01 + Your own cable	The cable length must be 10m or less.
	B	Your own cable	
GP* ³ (COM2)	C	Online adapter by Pro-face CA4-ADPONL-01 + Terminal block conversion adapter by Pro-face CA3-ADPTRM-01 + Your own cable	
	D	Online adapter by Pro-face CA4-ADPONL-01 + Your own cable	
IPC* ⁴	E	COM port conversion adapter by Pro-face CA3-ADPCOM-01 + Terminal block conversion adapter by Pro-face CA3-ADPTRM-01 + Your own cable	
	F	Your own cable	

*1 All GP models except AGP-3302B

*2 All ST models except AST-3211A

*3 All GP models except GP-3200 series and AGP-3302B

*4 Only the COM port which can communicate by RS-422/485 (2 wire) can be used.

 ■ COM Port of IPC (page 7)

A) When using the COM port conversion adapter (CA3-ADPCOM-01), the connector terminal block conversion adapter (CA3-ADPTRM-01) by Pro-face and your own cable

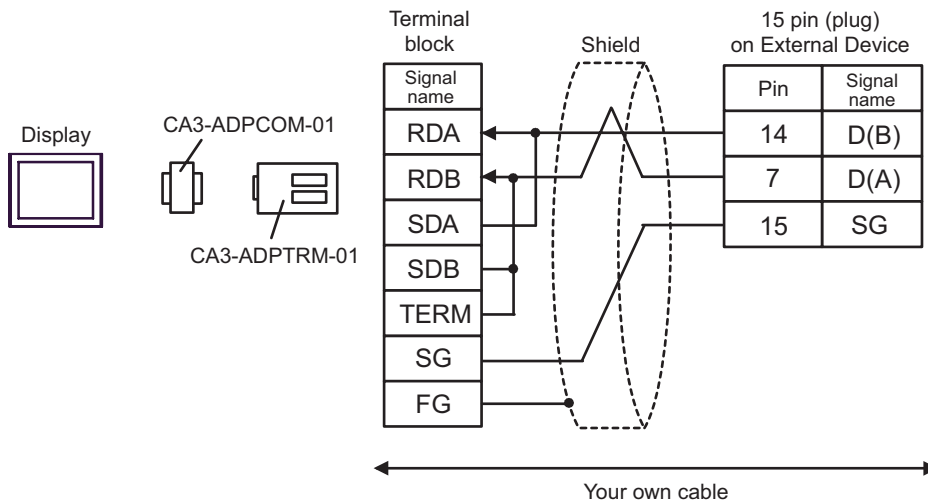

B) When using your own cable

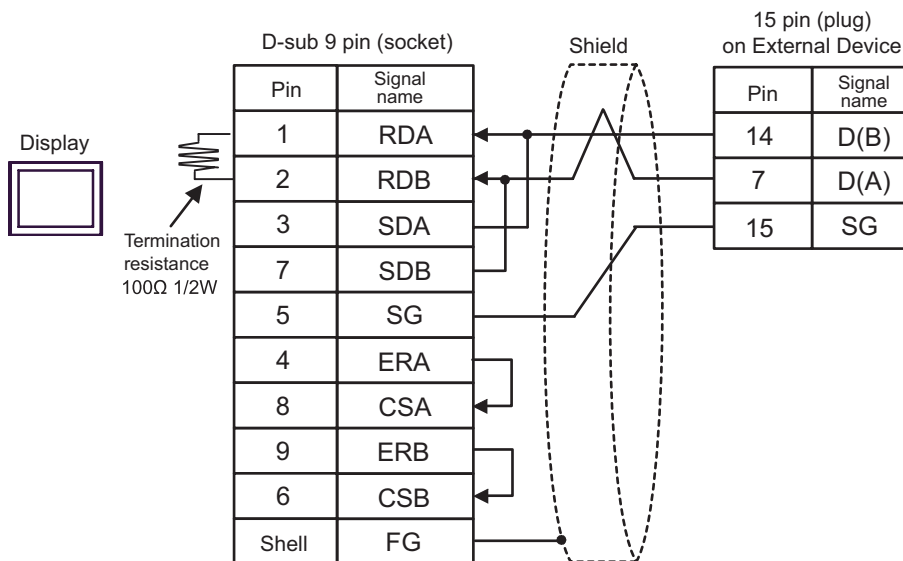

C) When using the online adapter (CA4-ADPONL-01), the connector terminal block conversion adapter (CA3-ADPTRM-01) by Pro-face and your own cable

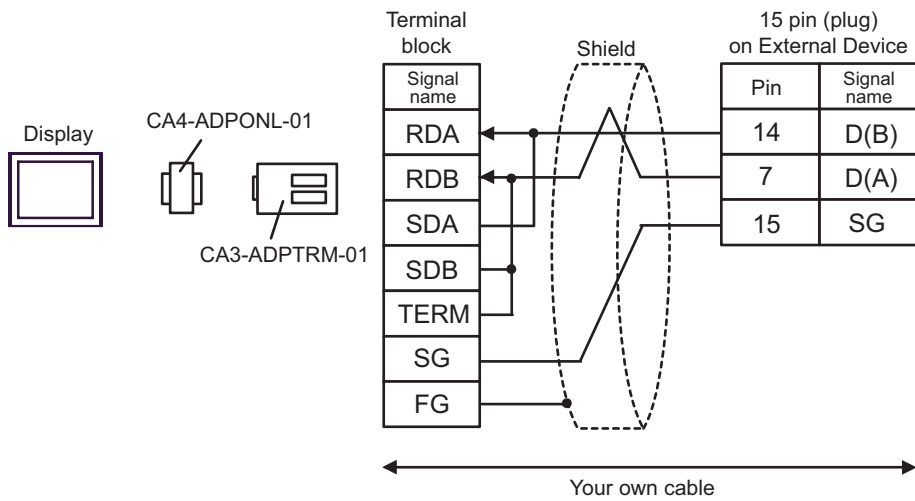

D) When using the online adapter (CA4-ADPONL-01) by Pro-face and your own cable

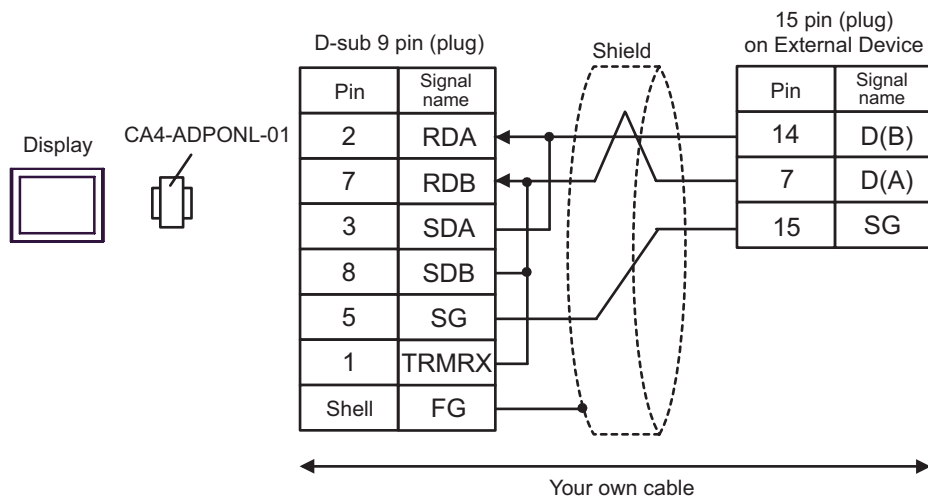

E) When using the COM port conversion adapter (CA3-ADPCOM-01), the connector terminal block conversion adapter (CA3-ADPTRM-01) by Pro-face and your own cable

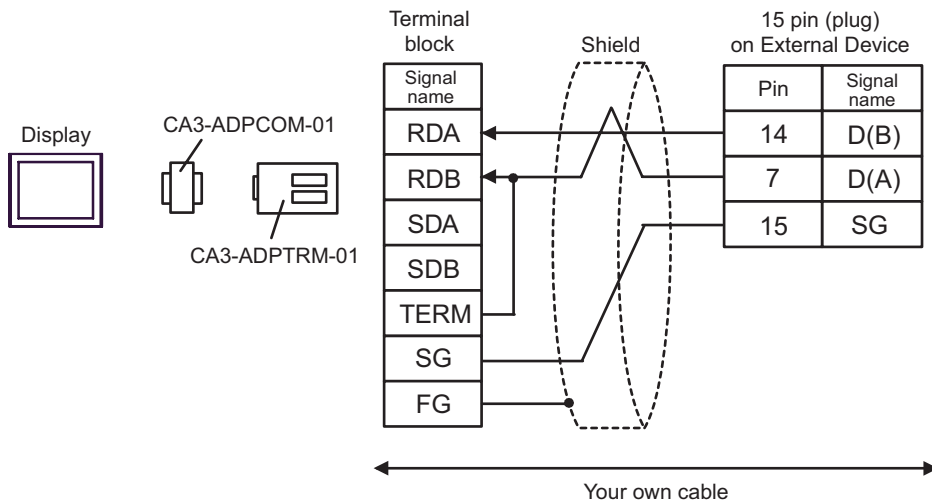

F) When using your own cable

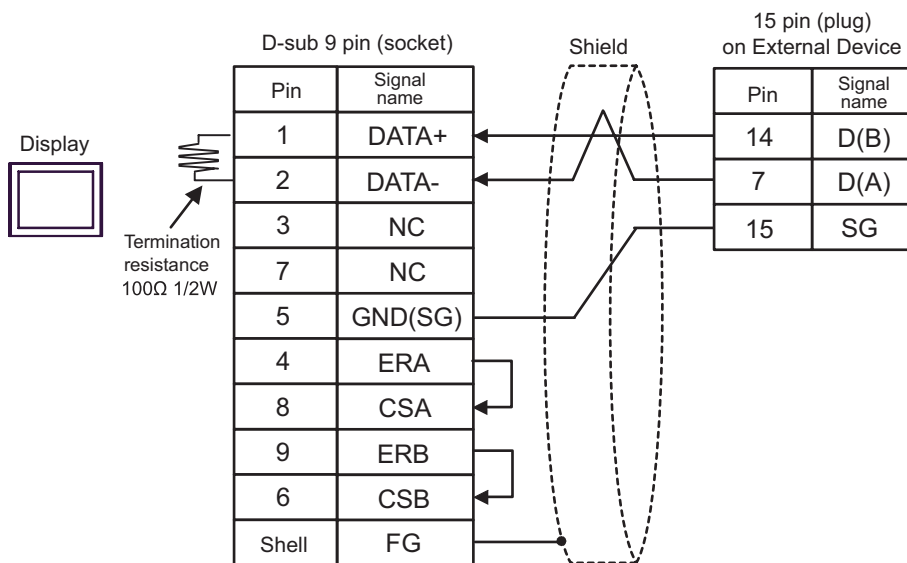

Cable Diagram 4

Display (Connection Port)	Cable		Notes
GP* ¹ (COM1) AGP-3302B (COM2) ST* ² (COM2)	A	COM port conversion adapter by Pro-face CA3-ADPCOM-01 + Terminal block conversion adapter by Pro-face CA3-ADPTRM-01 + Uni-Telway connection cable TSX SCP CU 4030 (3m) by Schneider Electric Industries	The cable length must be 10m or less. For n:1 connection, you need your own cable for connection between the Displays.
	B	Your own cable + Uni-Telway cable by Schneider Electric Industries TSX SCP CU 4030 (3m)	
GP* ³ (COM2)	C	Online adapter by Pro-face CA4-ADPONL-01 + Terminal block conversion adapter by Pro-face CA3-ADPTRM-01 + Uni-Telway cable by Schneider Electric Industries TSX SCP CU 4030 (3m)	
	D	Online adapter by Pro-face CA4-ADPONL-01 + Your own cable + Uni-Telway cable by Schneider Electric Industries TSX SCP CU 4030 (3m)	
IPC* ⁴	E	COM port conversion adapter by Pro-face CA3-ADPCOM-01 + Terminal block conversion adapter by Pro-face CA3-ADPTRM-01 + Uni-Telway connection cable TSX SCP CU 4030 (3m) by Schneider Electric Industries	
	F	Your own cable + Uni-Telway cable by Schneider Electric Industries TSX SCP CU 4030 (3m)	

*1 All GP models except AGP-3302B

*2 All ST models except AST-3211A

*3 All GP models except GP-3200 series and AGP-3302B

*4 Only the COM port which can communicate by RS-422/485 (2 wire) can be used.

 ■ COM Port of IPC (page 7)

- NOTE** • Line color for both D (A) and SG is white. As SG (red) and SG (white) are twisted pair, as well as D (A) and D (B), you can judge which line is SG or D (A).

A) When using the COM port conversion adapter (CA3-ADPCOM-01), the connector terminal block conversion adapter (CA3-ADPTRM-01) by Pro-face and Uni-Telway connection cable (TSX SCP CU 4030)

- 1:1 Connection

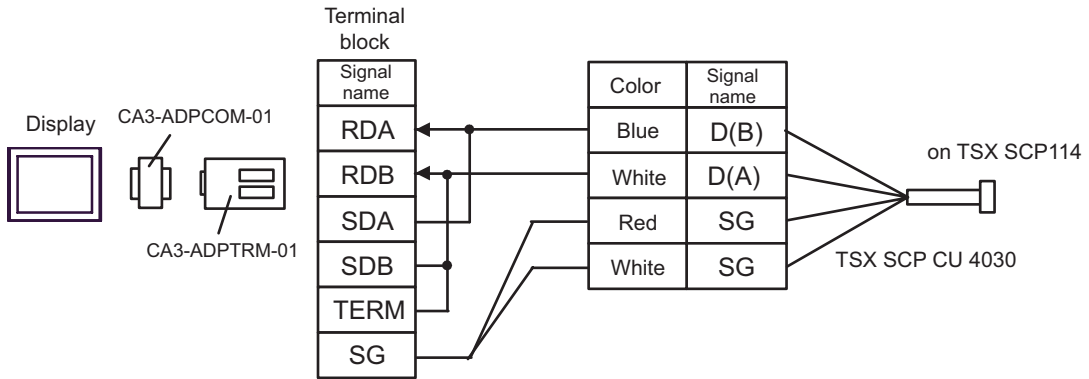

- n:1 Connection

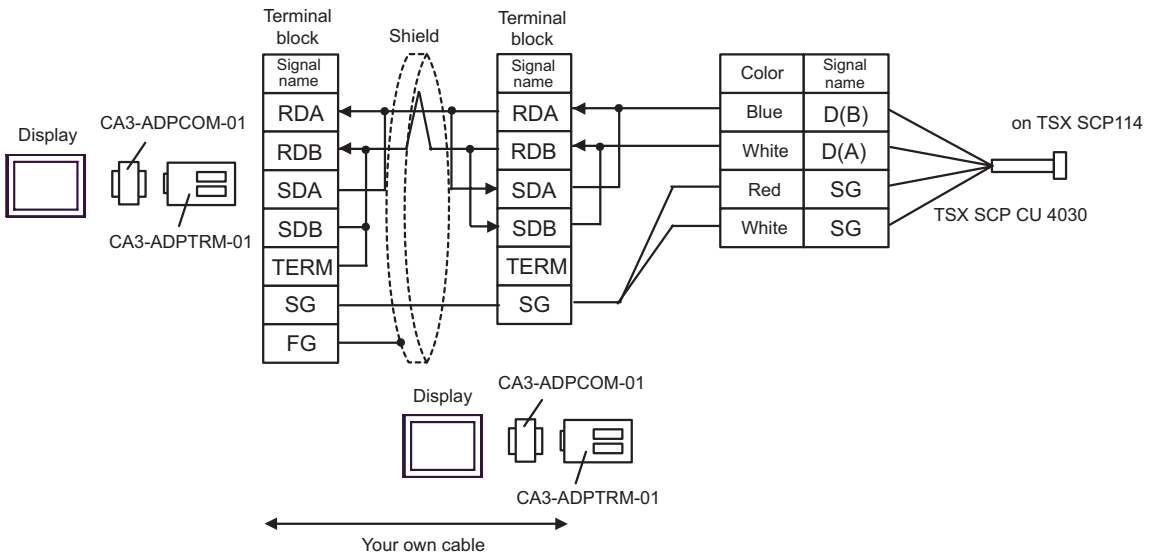

B) When using your own cable and Uni-Telway connection cable (TSX SCP CU 4030) by Schneider Electric Industries

- 1:1 Connection

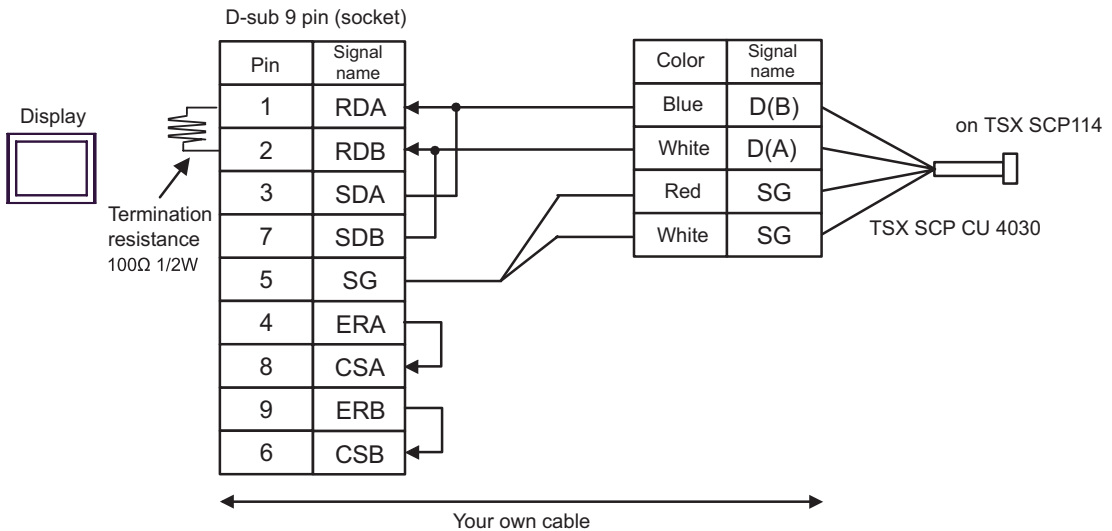

- n:1 Connection

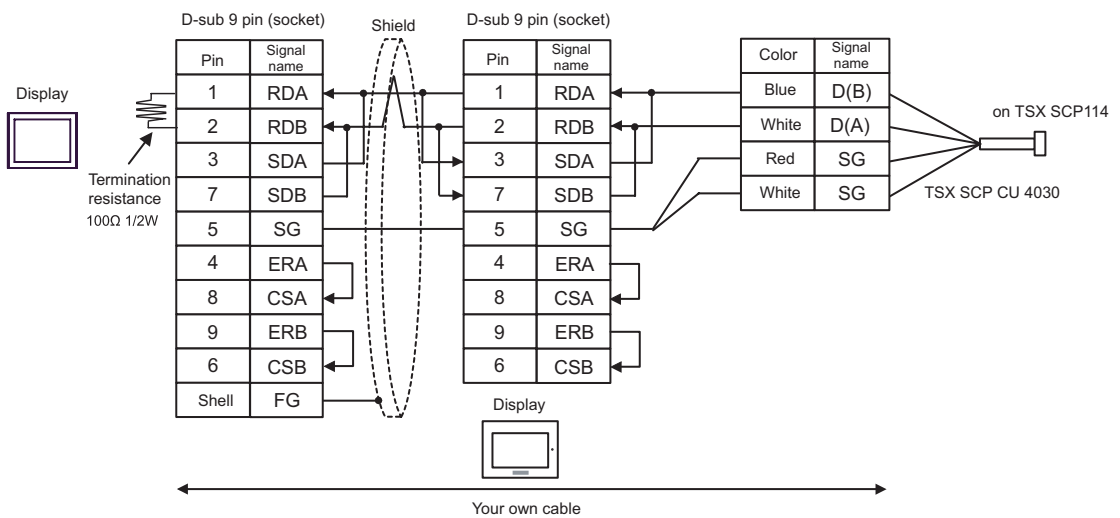

C) When using the online adapter (CA4-ADPONL-01), the connector terminal block conversion adapter (CA3-ADPTRM-01) by Pro-face and Uni-Telway connection cable (TSX SCP CU 4030) by Schneider Electric Industries

- 1:1 Connection

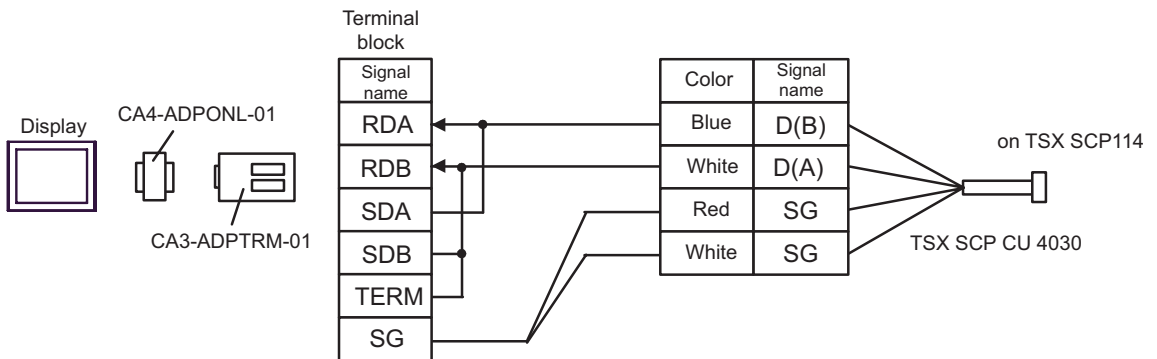

- n:1 Connection

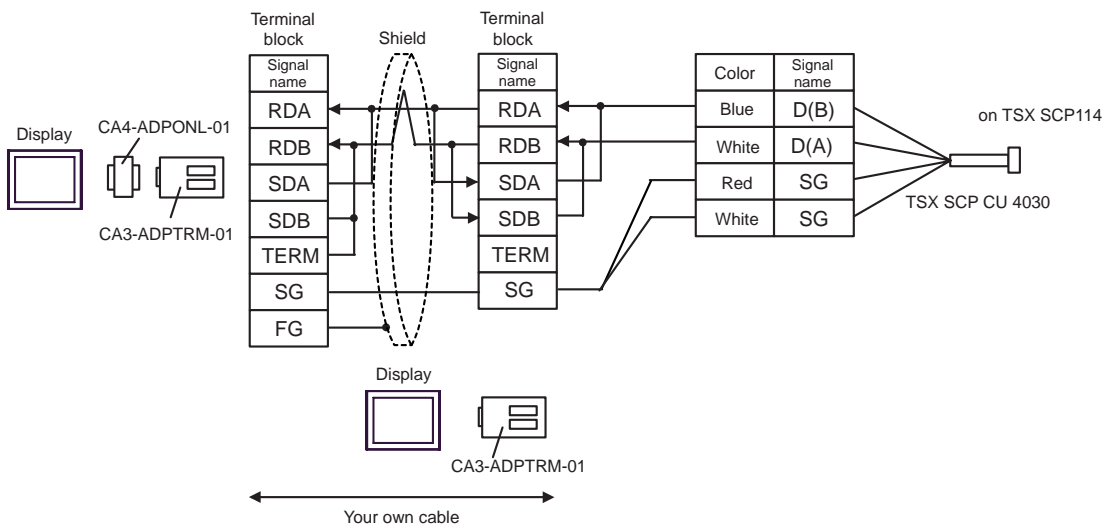

D) When using the online adapter (CA4-ADPONL-01) by Pro-face, your own cable and Uni-Telway connection cable (TSX SCP CU 4030) by Schneider Electric Industries

- 1:1 Connection

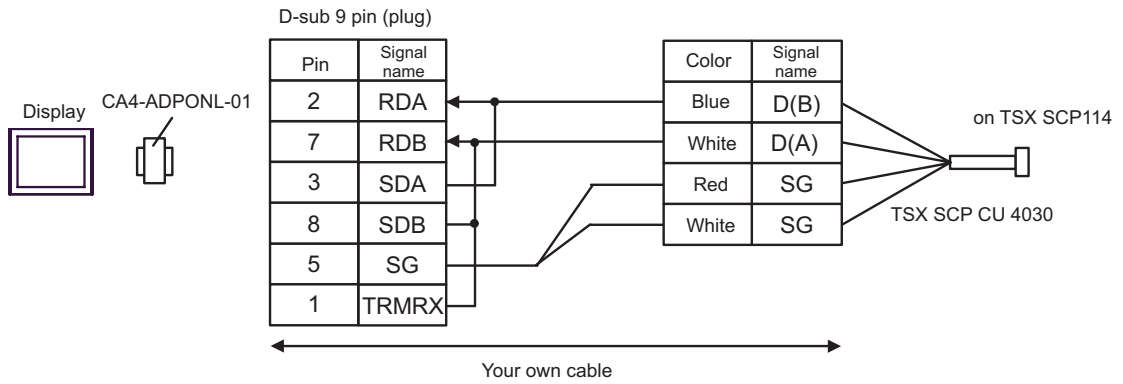

- n:1 Connection

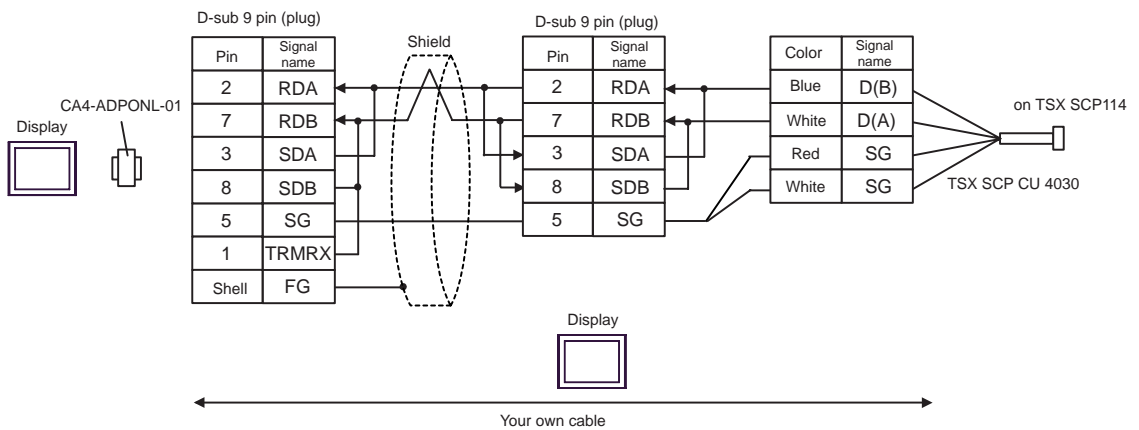

E) When using the COM port conversion adapter (CA3-ADPCOM-01), the connector terminal block conversion adapter (CA3-ADPTRM-01) by Pro-face and Uni-Telway connection cable (TSX SCP CU 4030)

- 1:1 Connection

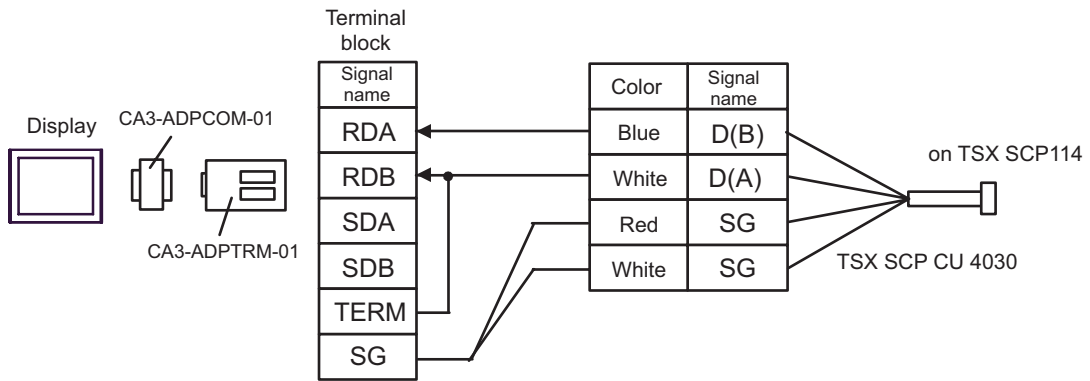

- n:1 Connection

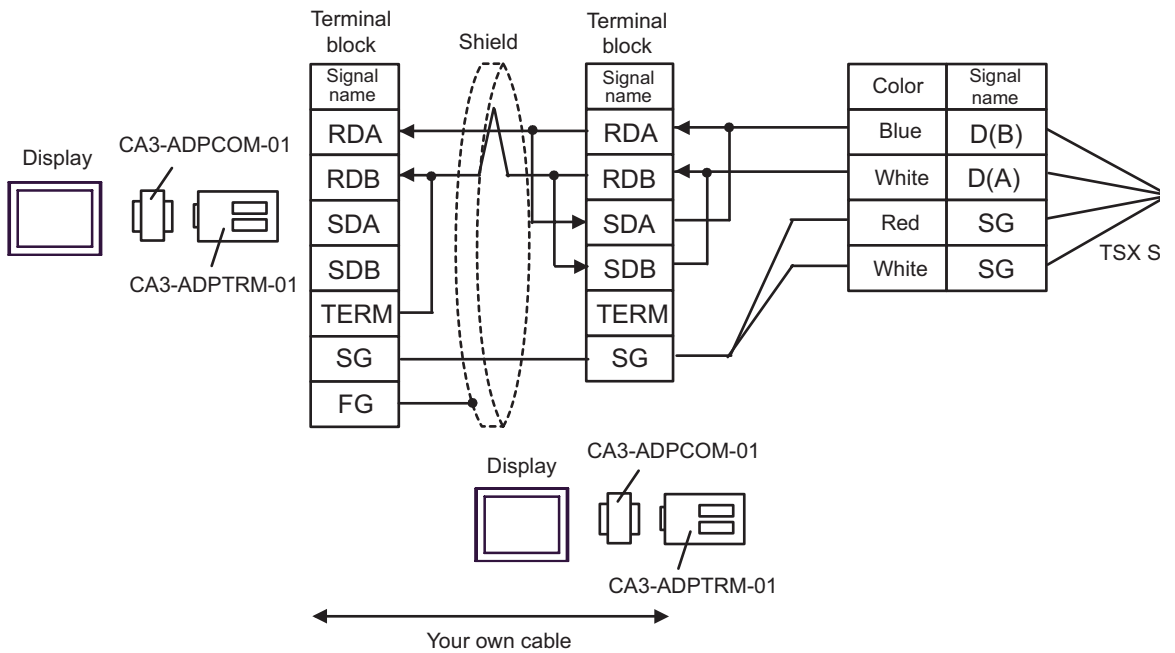

F) When using your own cable and Uni-Telway connection cable (TSX SCP CU 4030) by Schneider Electric Industries

- 1:1 Connection

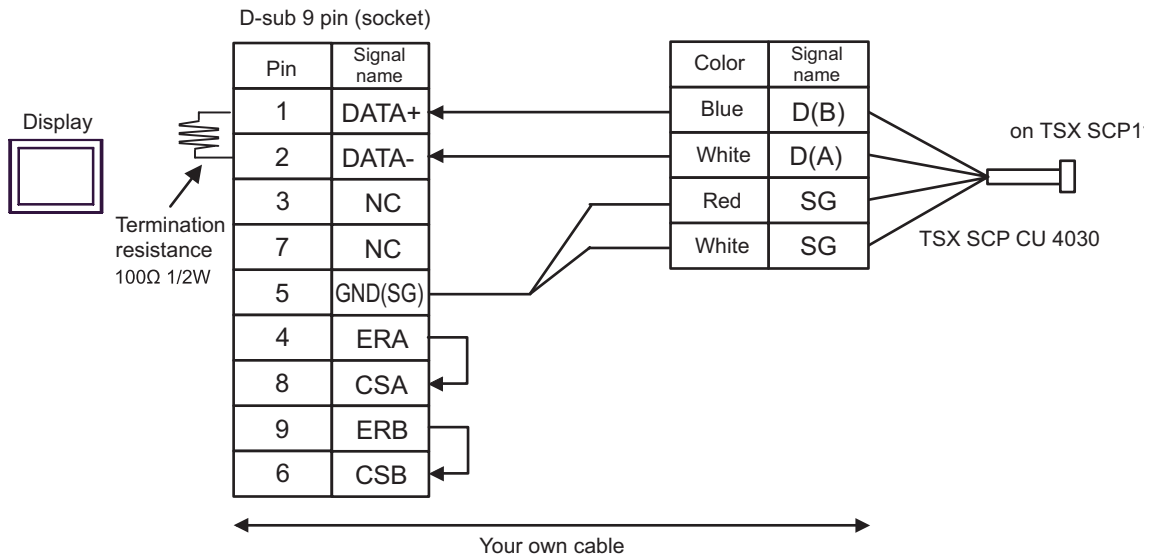

- n:1 Connection

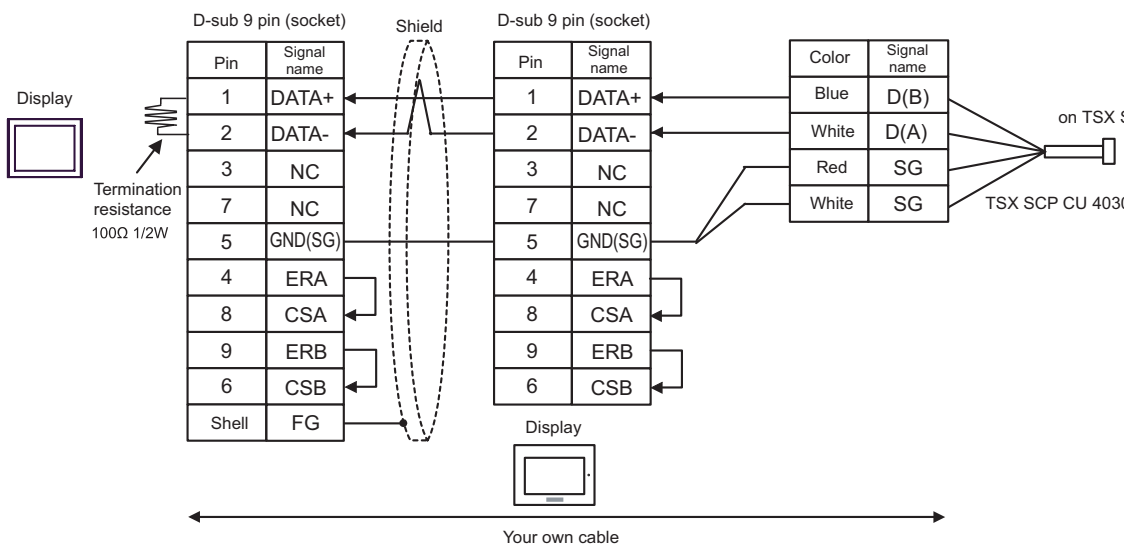

Cable Diagram 5

Display (Connection Port)	Cable		Notes
GP* ¹ (COM1) AGP-3302B (COM2) ST* ² (COM2)	A	COM port conversion adapter by Pro-face CA3-ADPCOM-01 + Terminal block conversion adapter by Pro-face CA3-ADPTRM-01 + Your own cable	The cable length must be 10m or less.
	B	Your own cable	
GP* ³ (COM2)	C	Online adapter by Pro-face CA4-ADPONL-01 + Terminal block conversion adapter by Pro-face CA3-ADPTRM-01 + Your own cable	
	D	Online adapter by Pro-face CA4-ADPONL-01 + Your own cable	
IPC* ⁴	E	COM port conversion adapter by Pro-face CA3-ADPCOM-01 + Terminal block conversion adapter by Pro-face CA3-ADPTRM-01 + Your own cable	
	F	Your own cable	

*1 All GP models except AGP-3302B

*2 All ST models except AST-3211A

*3 All GP models except GP-3200 series and AGP-3302B

*4 Only the COM port which can communicate by RS-422/485 (2 wire) can be used.

 ■ COM Port of IPC (page 7)

A) When using the COM port conversion adapter (CA3-ADPCOM-01), the connector terminal block conversion adapter (CA3-ADPTRM-01) by Pro-face and your own cable

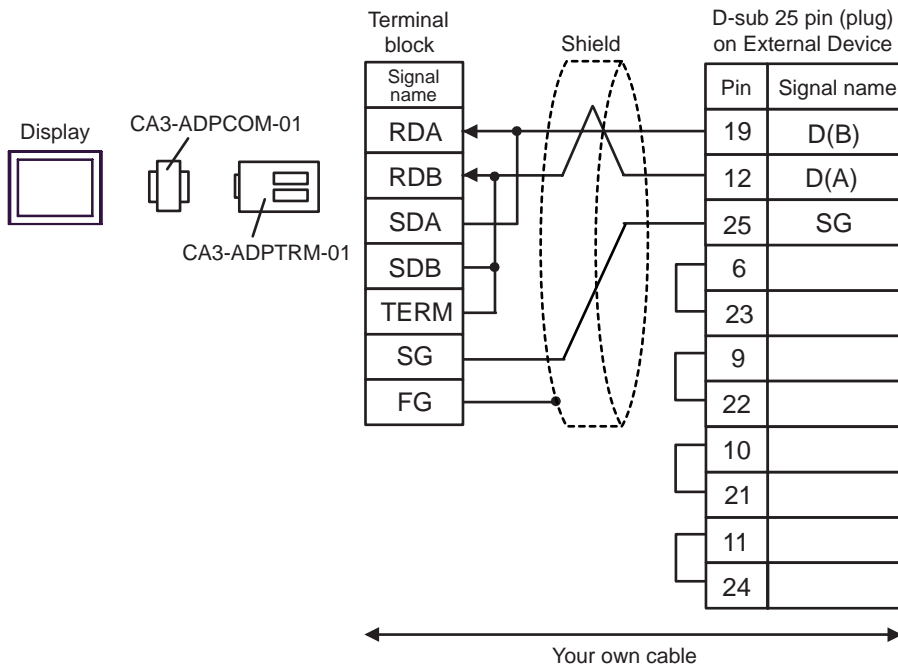

B) When using your own cable

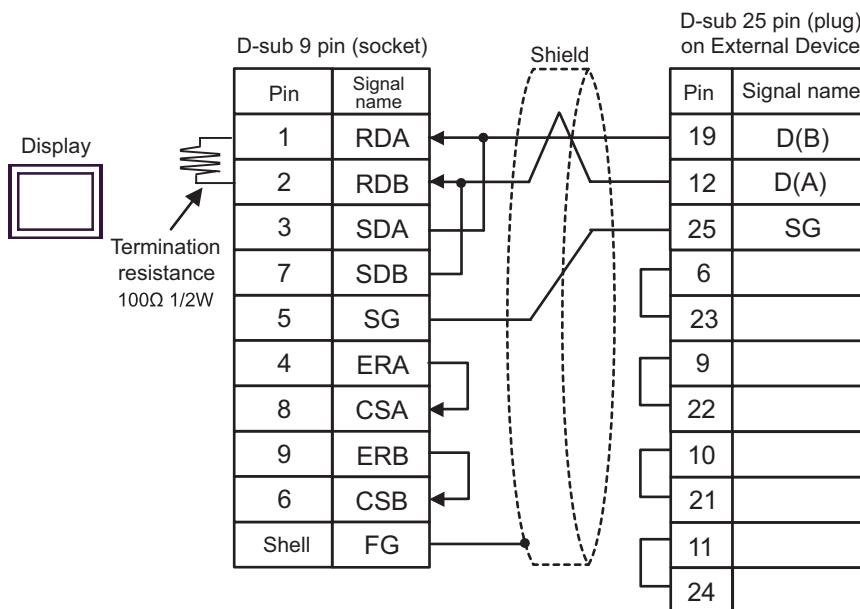

C) When using the online adapter (CA4-ADPONL-01), the connector terminal block conversion adapter (CA3-ADPTRM-01) by Pro-face and your own cable

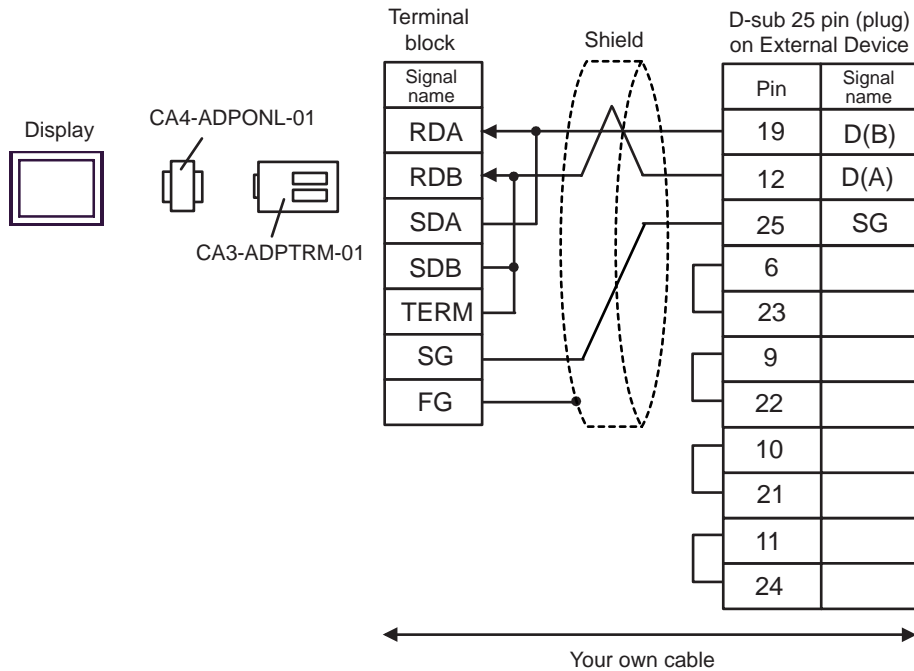

D) When using the online adapter (CA4-ADPONL-01) by Pro-face and your own cable

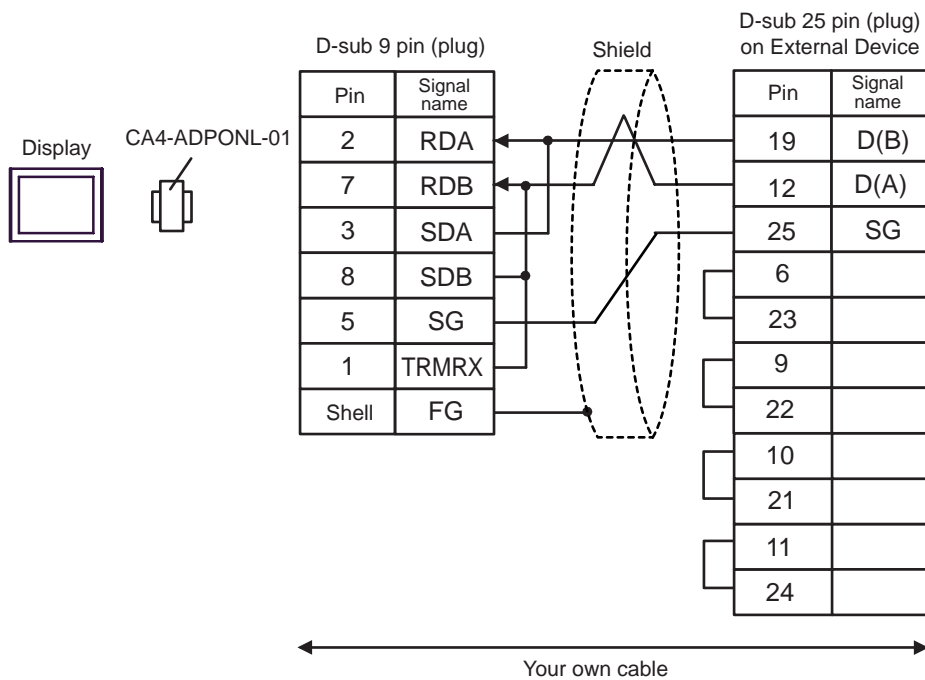

E) When using the COM port conversion adapter (CA3-ADPCOM-01), the connector terminal block conversion adapter (CA3-ADPTRM-01) by Pro-face and your own cable

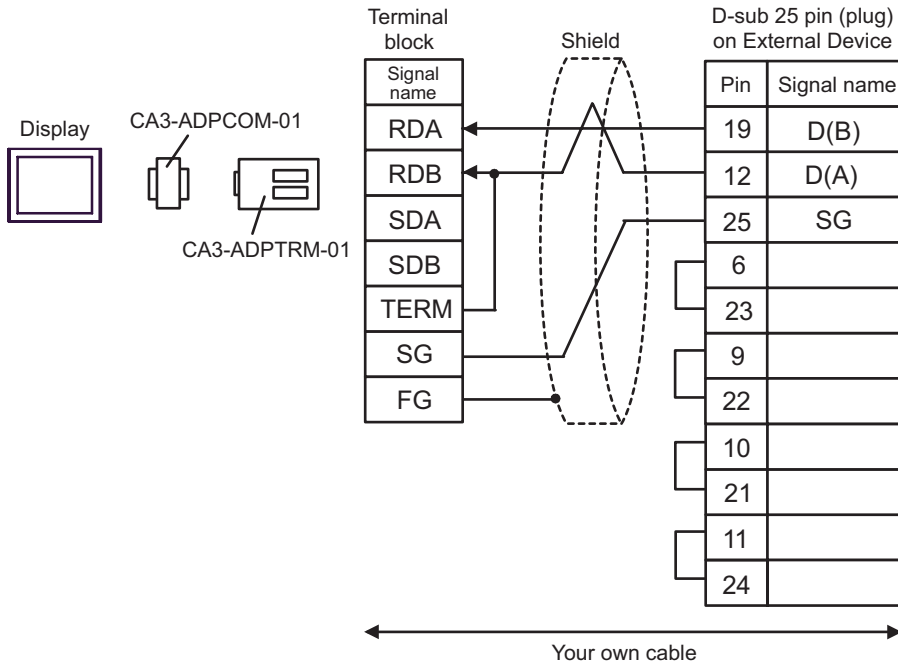

F) When using your own cable

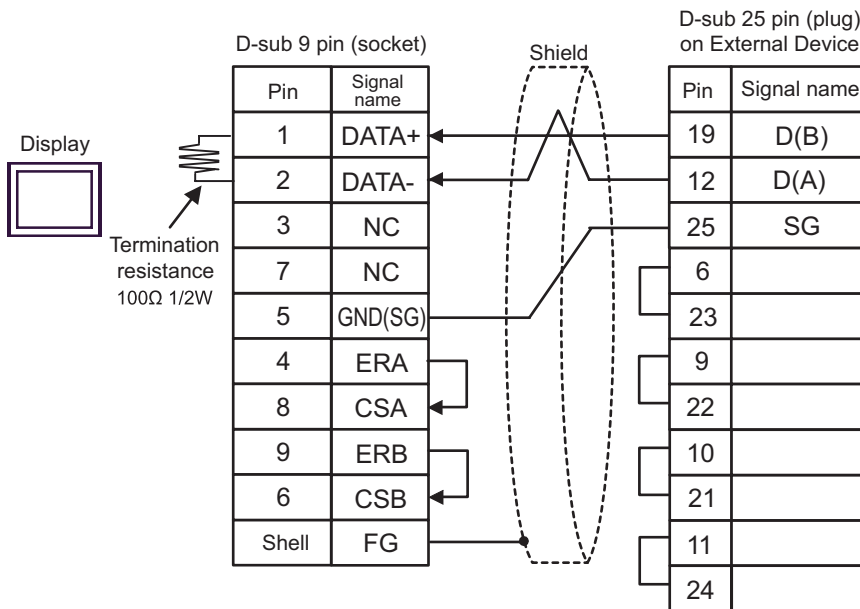

6 Supported Device

Range of supported device address is shown in the table below. Please note that the actually supported range of the devices varies depending on the External Device to be used. Please check the actual range in the manual of your External Device.

As it also varies depending on the "Software Configuration" setting of the ladder software, please check accordingly.

6.1 Nano Series

 This address can be specified as system data area.

Device	Bit Address	Word Address	32bits	Notes
Internal Word	%MW00000:X00 - %MW00255:X15	%MW00000 - %MW00255	[L/H] or [H/L] *1	*2 <div style="border: 1px solid black; padding: 2px; display: inline-block;">Bit 15</div>
Internal Double Word	%MD00000:X00 - %MD00254:X31	%MD00000 - %MD00254		*3 *4 <div style="border: 1px solid black; padding: 2px; display: inline-block;">+ 2</div> <div style="border: 1px solid black; padding: 2px; display: inline-block;">Bit 31</div>
Constant Word	---	%KW00000 - %KW00063		*5 <div style="border: 1px solid black; padding: 2px; display: inline-block;">Bit 15</div>
System Word	---	%SW00000 - %SW00127		<div style="border: 1px solid black; padding: 2px; display: inline-block;">Bit 15</div>
Internal Bit	%M00000 - %M00127	---		
System Bit	%S00000 - %S00127	---		

*1 High and low relationship of the stored data is specified by the [Double Word word order] setting of [Device Setting].

"4.1 Setup Items in GP-Pro EX ■ Device Setting" (page 26), "4.2 Setup Items in Off-Line Mode ■ Device Setting" (page 29)

*2 An access method at the time of Bit Set varies depending on the [Rest of the bits in this word] setting of [Device Setting].

- Clear

Bit 15

- Do not clear..... When you write the bit address, the Display reads the word address corresponding to that of the External Device first. Then, it changes the target bit address among the word data once read and returns the word data to the External Device. Note that the correct data may not be written if you change the word address value in the ladder program while the Display reads the data of the External Device and returns it to the External Device.

*3 An access method at the time of Bit Set varies depending on the [Rest of the bits in this word] setting of [Device Setting].

- Clear

Bit 31

- Do not clear..... When you write the bit address, the Display reads the word address corresponding to that of the External Device first. Then, it changes the target bit address among the word data once read and returns the word data to the External Device. Note that the correct data may not be written if you change the word address value in the ladder program while the Display reads the data of the External Device and returns it to the External Device.

*4 Use in 32-bit specification. When you perform 16-bit or bit specification, use %MW device. They use the same area inside the External Device.





*5 Write disable.



NOTE

- Please refer to the GP-Pro EX Reference Manual for system data area.
Cf. GP-Pro EX Reference Manual "Appendix 1.4 LS Area (Direct Access Method)"
- Please refer to the precautions on manual notation for icons in the table.
 "Manual Symbols and Terminology"

6.2 Micro Series

 This address can be specified as system data area.

Device	Bit Address	Word Address	32bits	Notes
Internal Word	%MW00000:X00 - %MW17543:X15	%MW00000 - %MW17543	[L/H] or [H/L] *1	*2 
Internal Double Word	%MD00000:X00 - %MD17542:X31	%MD00000 - %MD17542		*3 *4  
Constant Word	---	%KW00000 - %KW13879		*5 
System Word	---	%SW00000 - %SW00127		
Internal Bit	%M00000 - %M00255	---		
System Bit	%S00000 - %S00127	---		





- *1 High and low relationship of the stored data is specified by the [Double Word word order] setting of [Device Setting].
"4.1 Setup Items in GP-Pro EX ■ Device Setting" (page 26), "4.2 Setup Items in Off-Line Mode ■ Device Setting" (page 29)
- *2 An access method at the time of Bit Set varies depending on the [Rest of the bits in this word] setting of [Device Setting].
- Clear..... 
- Do not clear..... When you write the bit address, the Display reads the word address corresponding to that of the External Device first. Then, it changes the target bit address among the word data once read and returns the word data to the External Device. Note that the correct data may not be written if you change the word address value in the ladder program while the Display reads the data of the External Device and returns it to the External Device.
- *3 An access method at the time of Bit Set varies depending on the [Rest of the bits in this word] setting of [Device Setting].
- Clear..... 
- Do not clear..... When you write the bit address, the Display reads the word address corresponding to that of the External Device first. Then, it changes the target bit address among the word data once read and returns the word data to the External Device. Note that the correct data may not be written if you change the word address value in the ladder program while the Display reads the data of the External Device and returns it to the External Device.
- *4 Use in 32-bit specification. When you perform 16-bit or bit specification, use %MW device. They use the same area inside the External Device.
- *5 Write disable.

NOTE

- Please refer to the GP-Pro EX Reference Manual for system data area.
Cf. GP-Pro EX Reference Manual "Appendix 1.4 LS Area (Direct Access Method)"
- Please refer to the precautions on manual notation for icons in the table.
 "Manual Symbols and Terminology"

6.3 Premium Series

 This address can be specified as system data area.

Device	Bit Address	Word Address	32bits	Notes
Internal Word	%MW00000:X00 - %MW32463:X15	%MW00000 - %MW32463	[L/H] or [H/L] *1	*2 
Internal Double Word	%MD00000:X00 - %MD32462:X31	%MD00000 - %MD32462		*3 *4  
Constant Word	---	%KW00000 - %KW32759		*5 
System Word	---	%SW00000 - %SW00255		
Internal Bit	%M00000 - %M32633	---		
System Bit	%S00000 - %S00127	---		

*1 High and low relationship of the stored data is specified by the [Double Word word order] setting of [Device Setting].

"4.1 Setup Items in GP-Pro EX ■ Device Setting" (page 26), "4.2 Setup Items in Off-Line Mode ■ Device Setting" (page 29)

*2 An access method at the time of Bit Set varies depending on the [Rest of the bits in this word] setting of [Device Setting].

- Clear 

- Do not clear..... When you write the bit address, the Display reads the word address corresponding to that of the External Device first. Then, it changes the target bit address among the word data once read and returns the word data to the External Device. Note that the correct data may not be written if you change the word address value in the ladder program while the Display reads the data of the External Device and returns it to the External Device.

*3 An access method at the time of Bit Set varies depending on the [Rest of the bits in this word] setting of [Device Setting].

- Clear 

- Do not clear..... When you write the bit address, the Display reads the word address corresponding to that of the External Device first. Then, it changes the target bit address among the word data once read and returns the word data to the External Device. Note that the correct data may not be written if you change the word address value in the ladder program while the Display reads the data of the External Device and returns it to the External Device.

*4 Use in 32-bit specification. When you perform 16-bit or bit specification, use %MW device. They use the same area inside the External Device.

*5 Write disable.

NOTE

- Please refer to the GP-Pro EX Reference Manual for system data area.
Cf. GP-Pro EX Reference Manual "Appendix 1.4 LS Area (Direct Access Method)"
- Please refer to the precautions on manual notation for icons in the table.
 "Manual Symbols and Terminology"

7 Device Code and Address Code

Use device code and address code when you select "Device Type & Address" for the address type in data displays.

Device	Device Name	Device Code (HEX)	Address Code
Internal word	%MW	0000	Word Address
Internal Double Word	%MD	0002	Value of word address divided by 2
Constant Word	%KW	0003	Word Address
System Word	%SW	0004	Word Address

8 Error Messages

Error messages are displayed on the screen of Display as follows: "No. : Device Name: Error Message (Error Occurrence Area)". Each description is shown below.

Item	Description
No.	Error No.
Device Name	Name of External Device where error occurs. Name of External Device is a title of External Device set with GP-Pro EX. (Initial value [PLC1])
Error Message	Displays messages related to the error which occurs.
Error Occurrence Area	<p>Displays IP address or device address of External Device where error occurs, or error codes received from External Device.</p> <p>NOTE</p> <ul style="list-style-type: none"> • IP address is displayed such as "IP address(Decimal): MAC address(Hex)". • Device address is displayed such as "Address: Device address". • Received error codes are displayed such as "Decimal[Hex]".

Display Examples of Error Messages

"RHAA035: PLC1: Error has been responded for device write command (Error Code: 2 [02H])"

-
- NOTE**
- Refer to your External Device manual for details on received error codes.
 - Refer to "When an error is displayed (Error Code List)" in "Maintenance/Troubleshooting Manual" for details on the error messages common to the driver.
-