

# 22 | Enhancing Security

This chapter provides a basic explanation for "Enhancing security", and how to change settings in GP-Pro EX.

Please start by reading "22.1 Settings Menu" (page 22-2), and then turn to the corresponding page.

22.1	Settings Menu .....	22-2
22.2	Creating Limited Access Screens .....	22-5
22.3	Limiting Screen Access by Authority .....	22-8
22.4	Disable All Touch Operations for the Timing .....	22-11
22.5	Creating a Screen where Limited Access Parts are Placed.....	22-13
22.6	Show/Hide Parts/Drawings for a Specific Person to Use.....	22-23
22.7	Save Operation History .....	22-26
22.8	Password/User ID Input Window .....	22-31
22.9	Editing Password Online .....	22-34
22.10	Settings Guide.....	22-40
22.11	Restrictions .....	22-79

## 22.1 Settings Menu

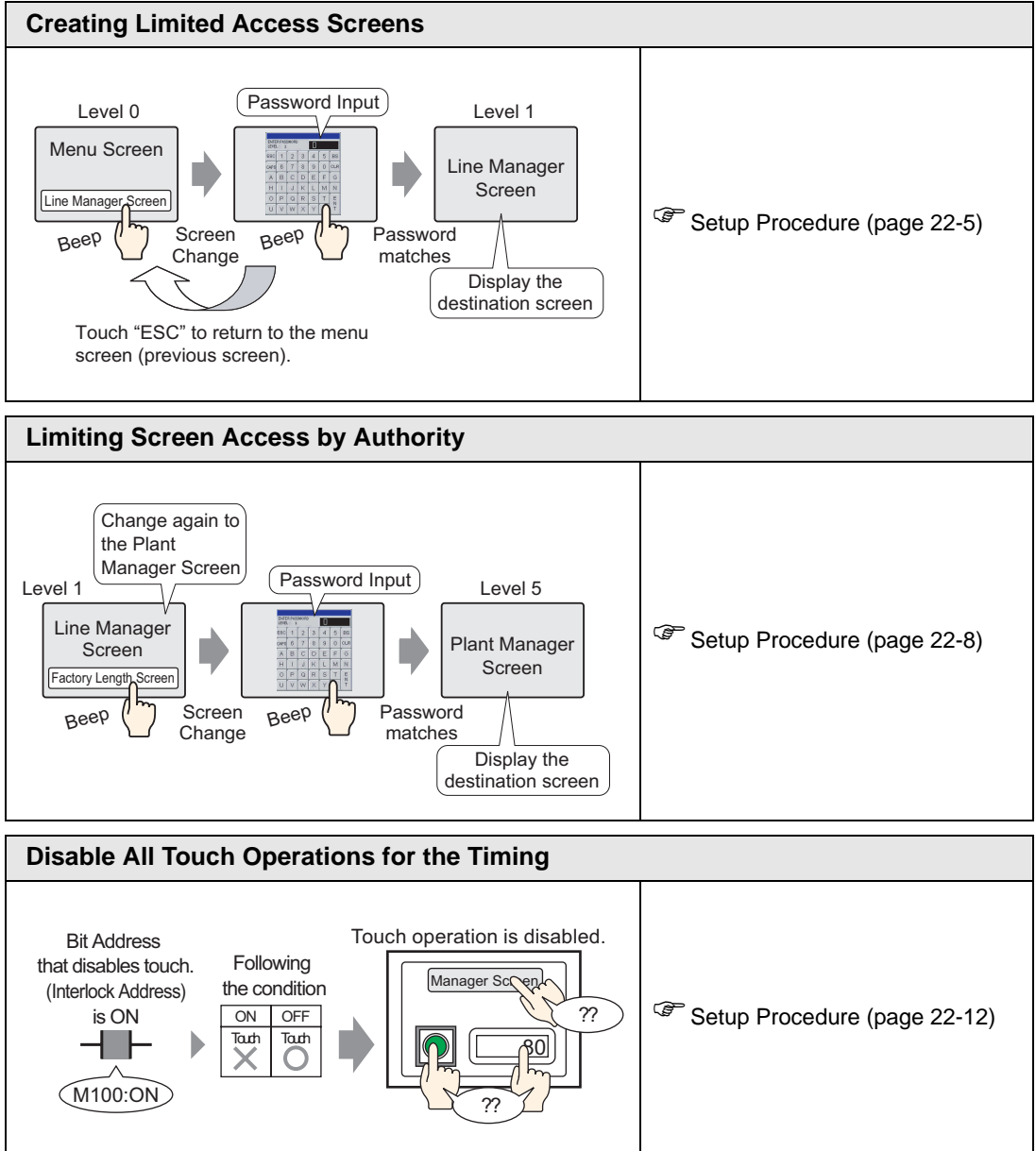

**Creating a Screen where Limited Access Parts are Placed**

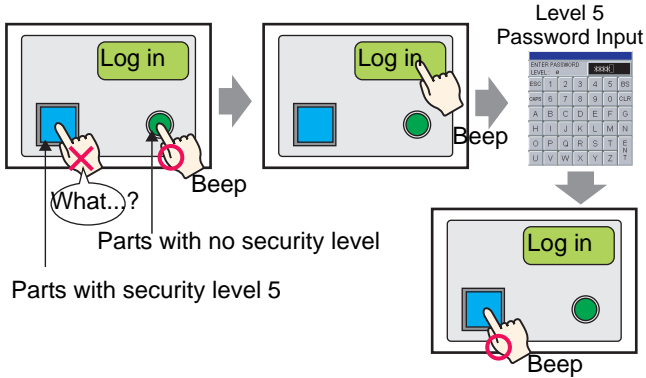

Setup Procedure (page 22-13)

**Show/Hide Parts/Drawings for a Specific Person to Use.**

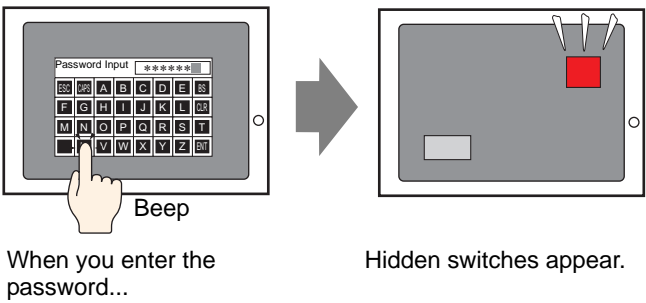

Setup Procedure (page 22-23)

**Save Operation History**

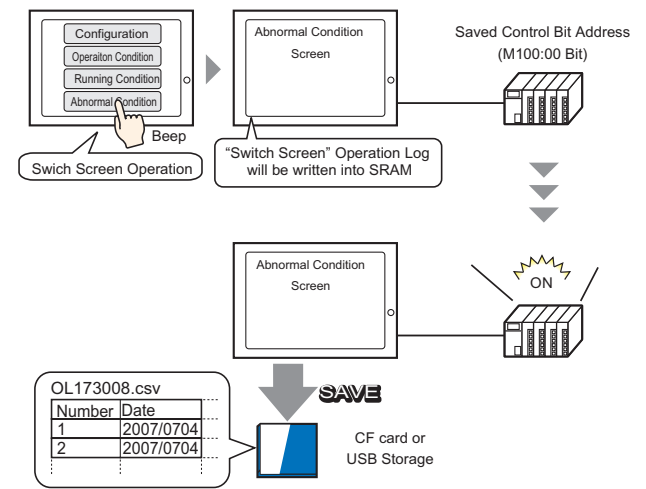

Setup Procedure (page 22-27)

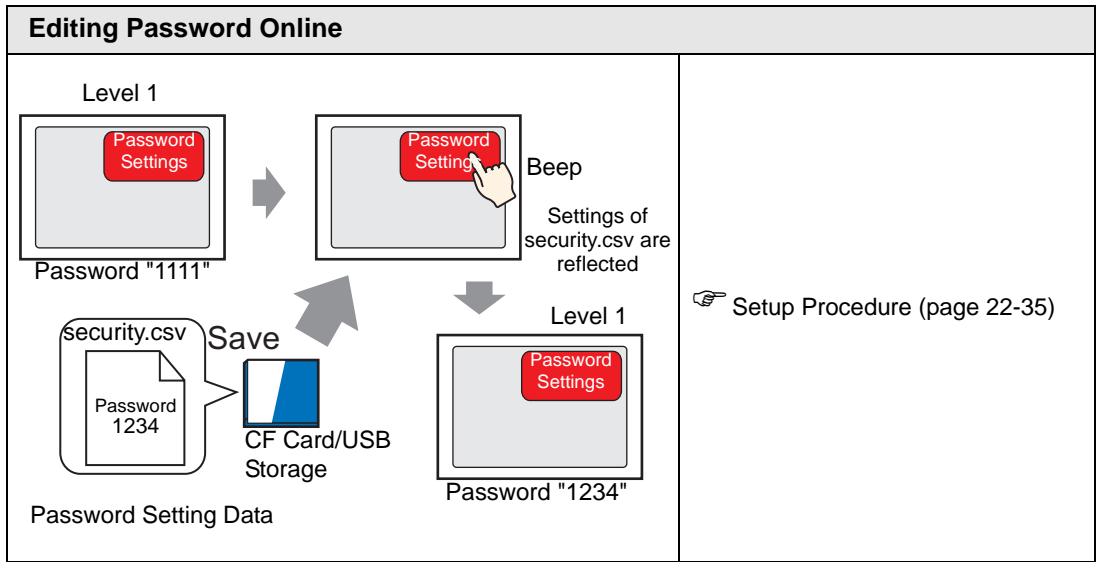

## 22.2 Creating Limited Access Screens

### 22.2.1 Setup Procedure

**NOTE**

- Please refer to the Settings Guide for details.  
 ☞ "22.10.1 Common (Security Settings) Settings Guide" (page 22-40)

Sets a Line Manager screen with a security level and password. This example uses Sampled Data B2, security level 1 and password 1111.

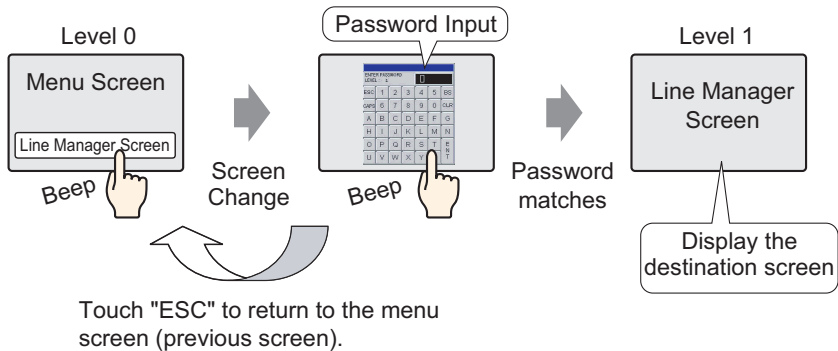

**NOTE**

- Security level 0 means no security is set.

1 From the [Common Settings (R)] menu, point to [Security (Q)] and select [Security Password (P)] or click  on the toolbar.

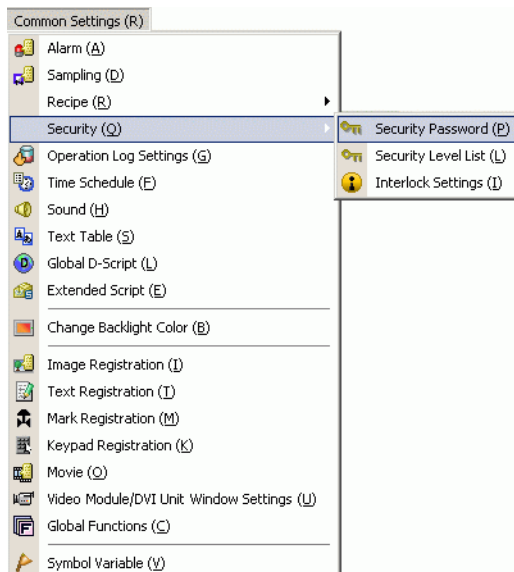

2 Password setting screen will open. Select the [Enable Security Function] check box, and type the password "1111" in [Level 1].

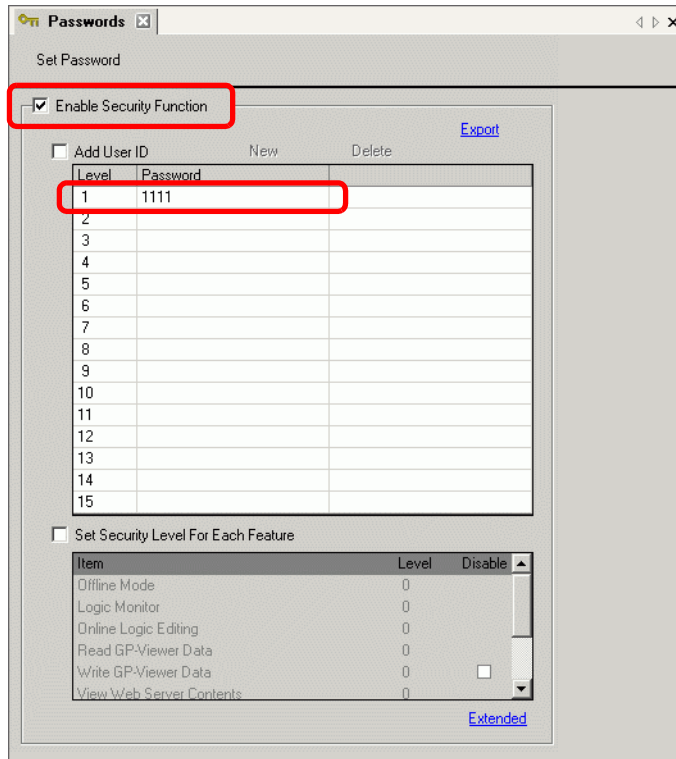

**NOTE**

- Set a password up to eight single-byte characters long.
- Select the [Add User ID] check box to add the User ID to the Password. As with the password, User IDs can be up to eight single-byte characters long.

3 From the [Common Settings (R)] menu, point to [Security (Q)] and select [Security Level List (L)].

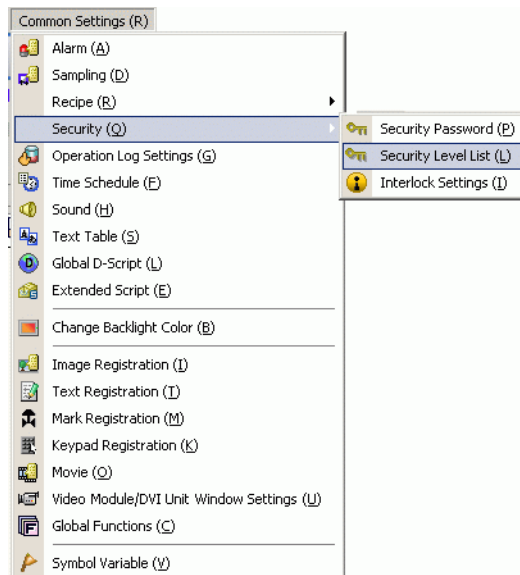

4 For [Sampled Data] B2, set the [Security Level] to 1. The security settings are complete.

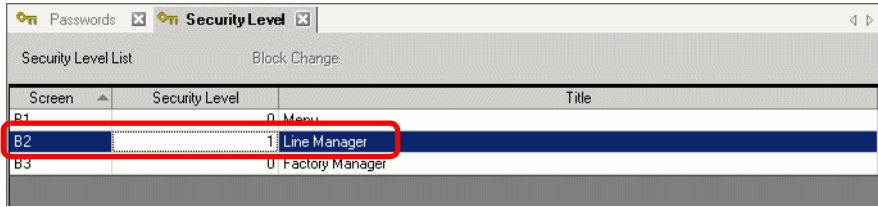

Screen	Security Level	Title
B1	0	Menu
B2	1	Line Manager
B3	0	Factory Manager

---

**NOTE**

- Once you log in, the security level you logged in at is enabled until you turn off the power.

If you logged in with high security, and you leave your desk, we recommend clearing the security level first to enhance security.

☞ "22.10.1 Common (Security Settings) Settings Guide ◆ Extended" (page 22-43)

---

## 22.3 Limiting Screen Access by Authority

### 22.3.1 Setup Procedure

**NOTE**

- Please refer to the Settings Guide for details.  
 ☞ "22.10.1 Common (Security Settings) Settings Guide" (page 22-40)

Sets a Plant Manager Screen with a security level and a password. This example uses Sampled Data B3, security level 5 and password 5555.

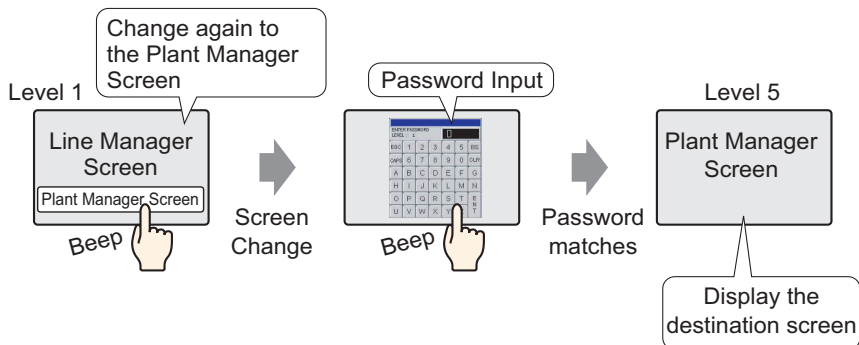

- 1 From the [Common Settings (R)] menu, point to [Security (Q)] and select [Security Password (P)] or click  on the toolbar.

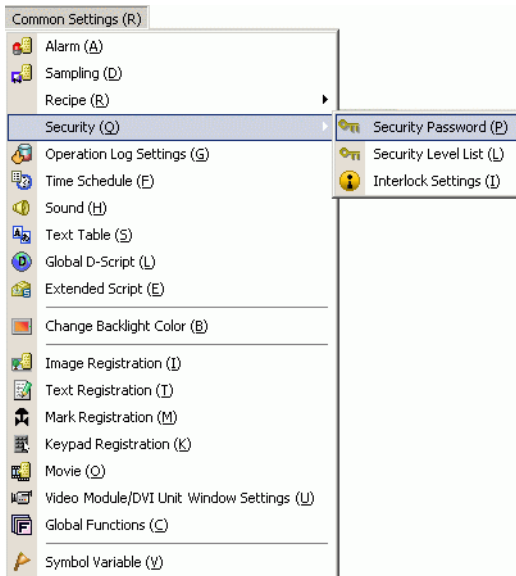

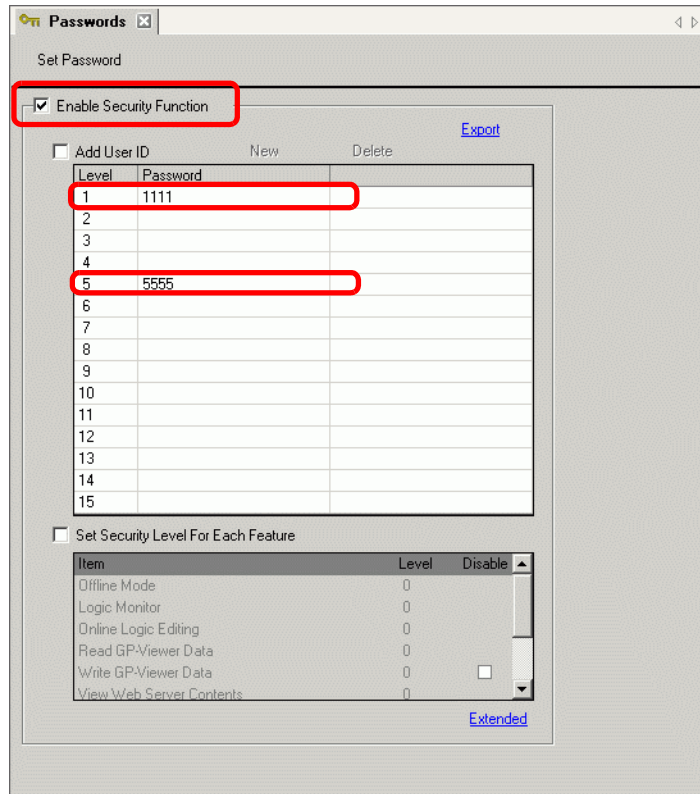

2 Password setting screen will open. Check [Enable Security Function] and input password "1111" in [Level 1] and password "5555" in [Level 5].

**NOTE**

- Set a password up to eight single-byte characters long.
- Select the [Add User ID] check box to add the User ID to the Password. As with the password, User IDs can be up to eight single-byte characters long.

3 From the [Common Settings (R)] menu, point to [Security (Q)] and select [Security Level List (L)].

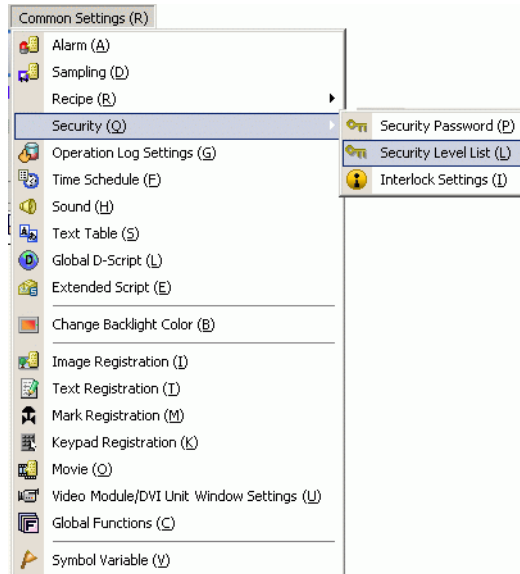

4 For [Sampled Data] B2, set the [Security Level] to 1. For [Sampled Data] B3, set the [Security Level] to 5. The security settings are complete.

The screenshot shows a window titled 'Security Level List' with a 'Block Change' button. It contains a table with the following data:

Screen	Security Level	Title
B1	0	Menu
B2	1	Line Manager
B3	5	Factory Manager

**NOTE**

- Once you log in, the security level you logged in at is enabled until you turn off the power.  
If you logged in with high security, and you leave your desk, we recommend clearing the security level first to enhance security.
- ☞ "22.10.1 Common (Security Settings) Settings Guide ◆ Extended" (page 22-43)

## 22.4 Disable All Touch Operations for the Timing

### 22.4.1 Introduction

You can restrict screen touch operations by using the Global Interlock Address. Touch operation is enabled only when the bit address that is set for the Interlock Address meets the Touch Enable Condition.

- When the Touch Enable Condition is "Bit ON".  
The touch action will only work when the set Interlock Address is ON.

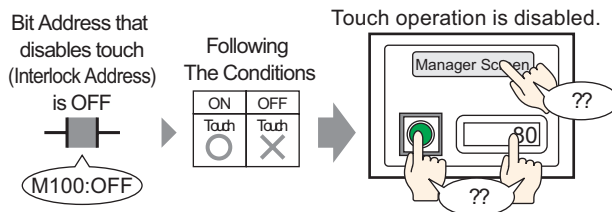

- When the Touch Enable Condition is "Bit OFF".  
The touch action will only work when the set Interlock Address is OFF.

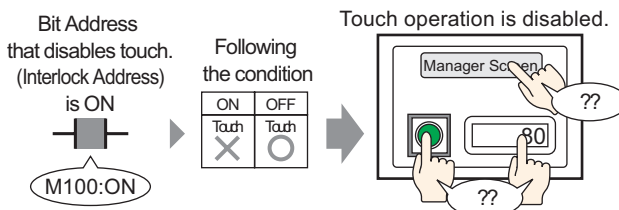

## 22.4.2 Setup Procedure

**NOTE**

- Please refer to the Settings Guide for details.  
 ☞ "22.10.1 Common (Security Settings) Settings Guide ■ Interlock Settings" (page 22-47)

In the Touch Enable Condition, select Enable when Bit is OFF to set the touch operation to be disabled when Bit (M100) designated by the Interlock Address is ON.

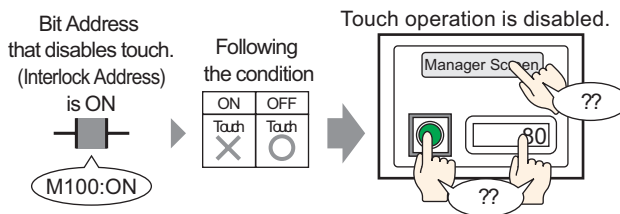

- 1 From the [Common Settings (R)] menu, point to [Security (Q)] and select [Interlock Settings (I)] or click ⓘ on the tool bar.
- 2 Opens the Interlock Settings screen. Select the [Use Global Interlock] check box.

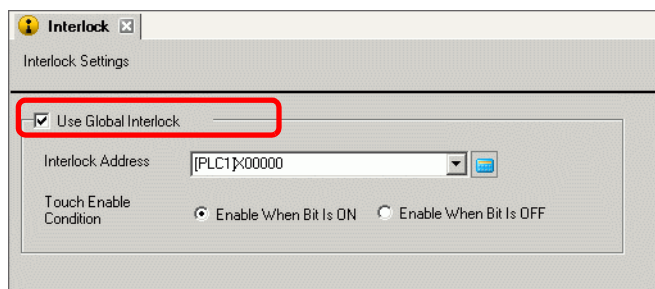

- 3 Set the Bit Address (for example, M100) that sets the Touch Enable Condition in [Interlock Address].

Click ⓘ to display an address input keypad.

Select device "M", input "100" as the address, and press the "Ent" key.

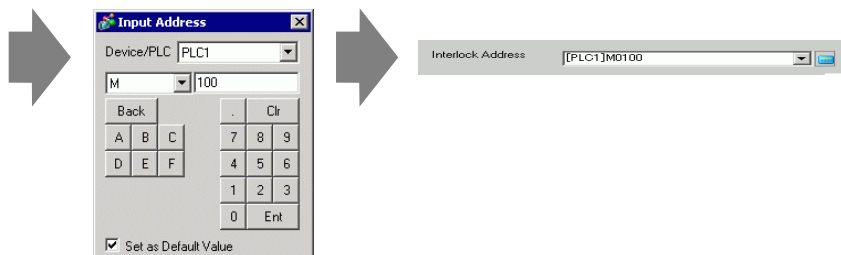

- 4 Use the [Touch Enable Condition] field to set up a condition that enables touch operations. (For example, select "Enable When Bit is Off" to enable touch operations when the bit is off.)

## 22.5 Creating a Screen where Limited Access Parts are Placed

### 22.5.1 Introduction

Touch operation can be restricted by setting a security level for touch-operating parts. Touch operation of the parts will be enabled only when you log in with a level higher than the security level set for the parts.

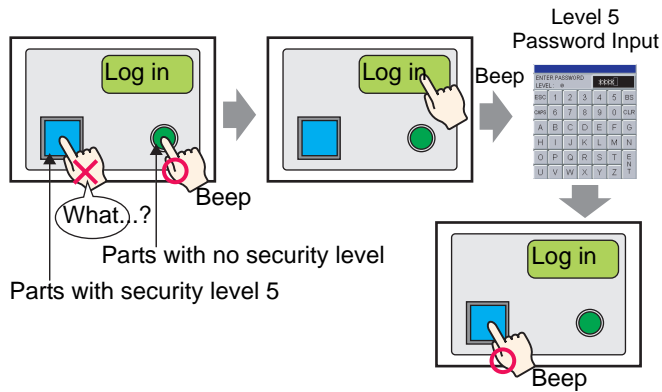

## 22.5.2 Setup Procedure

**NOTE**

- For how to set security level to the screen, refer to the following.
  - ☞ "22.3 Limiting Screen Access by Authority" (page 22-8)
- Please refer to the Settings Guide for details on special switches.
  - ☞ "10.15.4 Special Switch ◆ Security" (page 10-77)
- For details on the parts that you can set security level, refer to the following.
  - ☞ "22.5.3 Security Setting for Each Part ■ Each part for which a security level can be set." (page 22-17)

Set security level 5 to the switch to enable switch operation only when logged in with level 5. Also, place a special switch to log in when you have only security level lower than level 5.

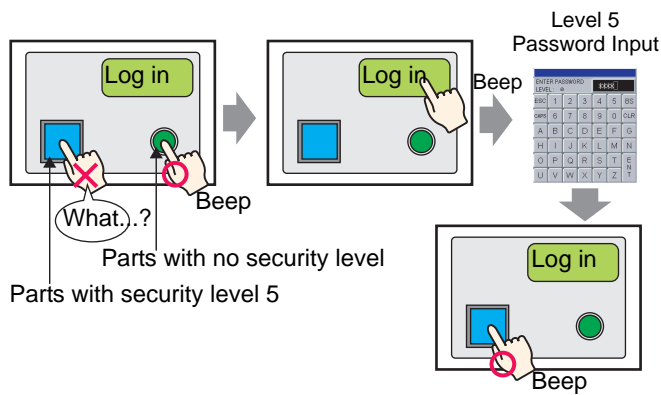

- 1 Select a switch for which you want to change the security level, and then click [Change Attributes (M)] from the [Edit (E)] menu, or right-click on the switch and select [Change Attributes (M)] from the menu.

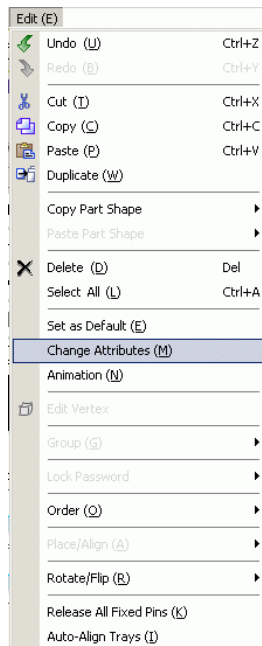

**NOTE**

- Settings dialog box will be displayed also by double-clicking the switch.

2 When the settings dialog box appears, click the [Switch Common] tab.

3 Select the [Enable Security Levels] check box in [Interlock Feature] and set "5" for the level.

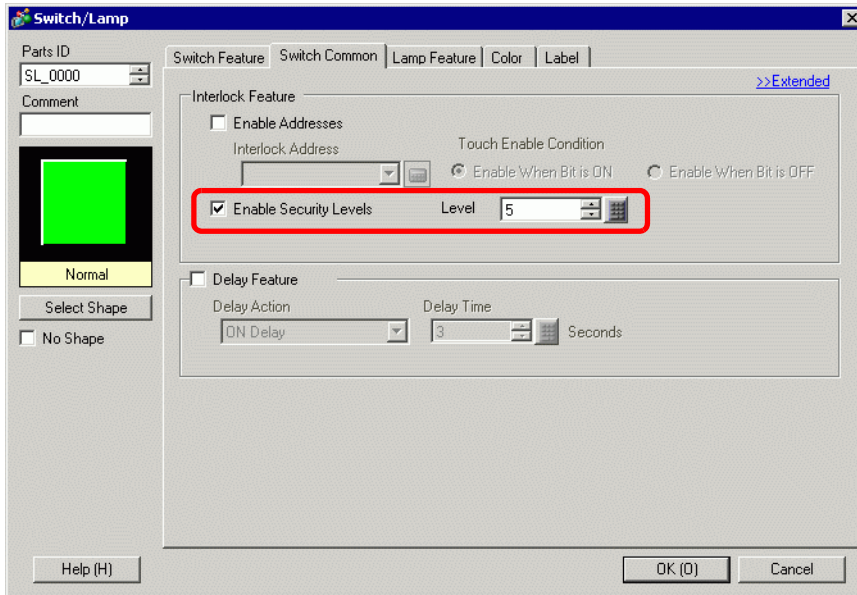
**NOTE**

- You can also set the interlock feature for each part by selecting the [Enable Addresses] check box and setting the interlock address.

4 Click [OK] and the settings dialog box is closed.

5 From the [Parts (P)] menu, point to [Switch/Lamp (C)] and select [Special Switch (P)] or click , and place the Switch on the screen.

6 Double-click the placed Switch part. The following dialog box appears.

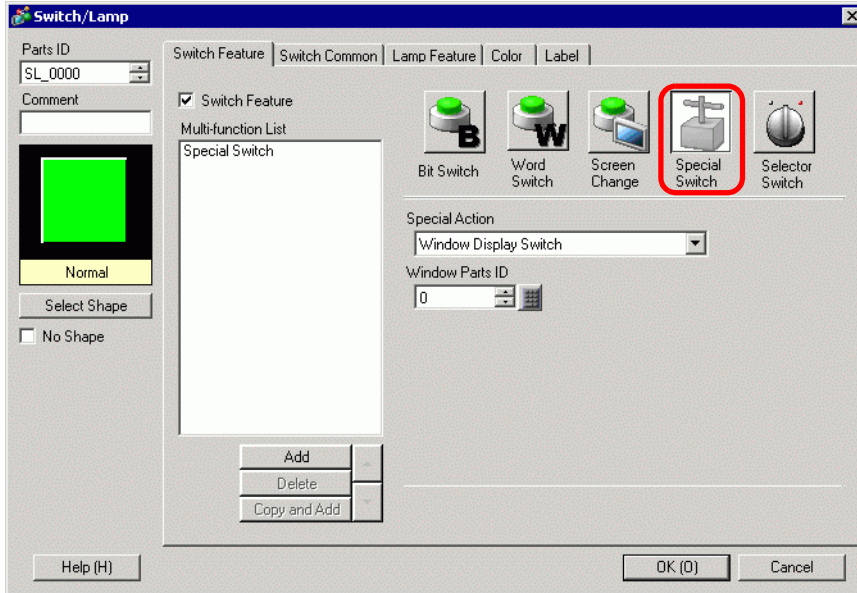

7 In [Select Shape], select the Switch shape.

8 Select [Security] in [Special Action].



9 Select [Log in] in [Action].

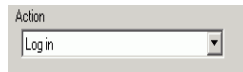

10 As required, set the color and display text on the [Color] tab and [Label] tab, and click [OK].

**NOTE**

- Depending on the shape, you may not be able to change the color.
- When you select a switch and press the [F2] key, you can directly edit the Label text. When [Text Table] is selected, you can change the Text Table to be displayed.
- You can set [Log off] in [Action] of the special switch to create a switch for clearing the security level.



### 22.5.3 Security Setting for Each Part

■ **Each part for which a security level can be set.**

From among the touch operating parts, you can set each security level for parts with the following features.

Parts	Feature Details
<b>Switch Lamp</b>	Bit Switch
	Word Switch
	Screen Change
	Special Switch (All features)
	Selector Switch
<b>Data Display</b>	Numeric Display (When Allow Input is set)
	Text Display (When Allow Input is set)
<b>Sampling Display</b>	When Edit Data is set
<b>Show CSV</b>	When Edit Data is set

■ **Action of the parts for which a security level is set**

◆ **When a security level is set for the part.**

You can set interlock with security level if you set a security level for each part.

Current security level < Security level for the part

Interlock is on (the part is not operated)

Current security level >= Security level for the part

Interlock is disabled (the part is operated)

◆ **Multiple parts with security level are placed**

Only the parts with a security level not higher than the current security level can operate.

◆ **Displaying interlocked condition with the security level of switch parts**

For switch parts, if you select the [Show Interlocked Condition] check box in [Extended] on the [Switch Common] tab, you can set part shapes and labels for the interlocked condition with security levels.

However, this is common to the interlock feature with [Enable Addresses] enabled.

Therefore, you cannot set the shape of the interlock switch separately between addresses and security levels.

◆ **When input order is set for the data display**

A part with a level higher than the current security level cannot be edited even when it is the time to edit the part according to the input order.

◆ **When using with the interlock setting of [Security] in the [Common Settings] menu**

Security setting for each part can be set together with the interlock setting of [Security] in the [Common Settings] menu.

If both are set, when either of them meets the interlock condition, the operation cannot be performed.

◆ **When operating from GP-Viewer**

As for the operation from GP-Viewer, interlock is determined according to the current security level on the GP-Viewer side regardless of Synchronous/Asynchronous Mode. It is not dependent on the security level on the server (display unit) side.

---

**NOTE**

- For details, refer to the GP-Viewer EX Operation Manual.
-

■ Log in/Log off

◆ Log in

If you set [Log in] in [Action] of the special switch, you can create a log-in switch for changing the current security level.

When you touch the log-in switch, the Security Password screen appears.

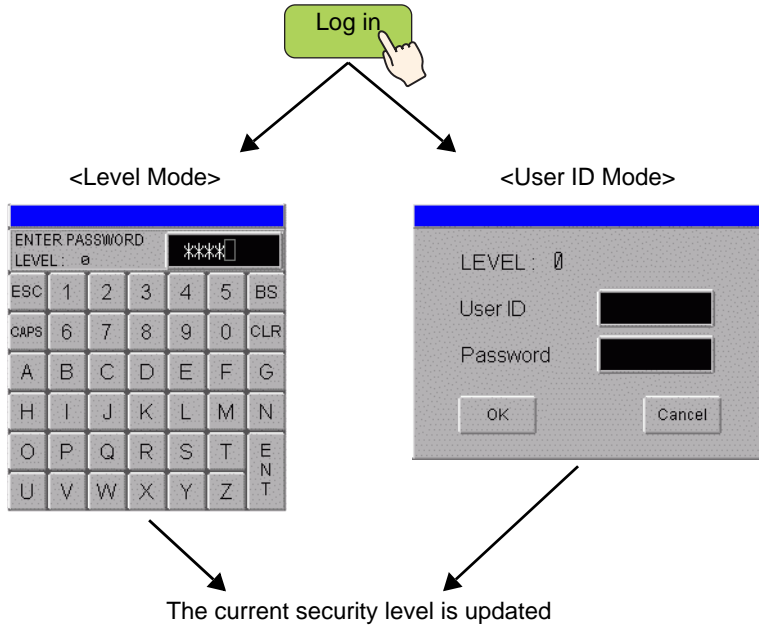

- For Level Mode, any password of any level is accepted if a password is set for the level in the security setting. When a proper password is entered, the "current security level" is changed to the level for which the password is set.

Example: Password Settings

Level	Password
1	aaa
2	
3	ccc

- Enter the password "aaa" and press [ENT] -> Current security level = 1
- Enter the password "ccc" and press [ENT] -> Current security level = 3

- For User ID Mode, any ID is accepted if the ID exists for the security setting. When a proper password is entered, the "current security level" is changed to the level for which the ID is set, and the system variable "H\_LoginUserID" is also updated.

Example: Password Settings

Level	ID	Password
1	AAA	aaa
2	BBB	bbb
2	CCC	ccc

- Enter the ID "AAA" and press [OK] -> Current security level = 1
  - Enter the ID "BBB" and press [OK] -> Current security level = 2
  - Enter the ID "CCC" and press [OK] -> Current security level = 2
- You can log in to the same level as or lower level than the current security level.
  - Regardless of the security level of the screen on which a log-in switch is placed, you can log in any level.
  - On the password input screen for the log in, "0" is displayed in the "LEVEL" field.

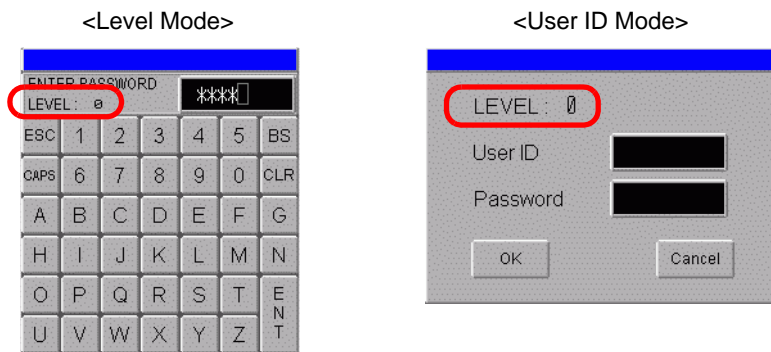

- On the password input screen, when [ESC] (for Level Mode) or [Cancel] (for User ID Mode) is pressed, the password input screen disappears and the screen before login is displayed.
- If the security level clear time has passed while password input screen is displayed, the password input screen disappears and the screen before log in is displayed
- On the password input screen, if a password that does not exist is entered and [ENT] is pressed (in Level Mode), or if different password is entered and [OK] is pressed (in User ID Mode), an error message is displayed.

- If other action with the other security setting occurs while the password input screen is displayed for log in, the following behavior will take place.  
Interrupting action during the password input screen display.

Interrupting Action	Relationship between Interrupt Request Level and Current Level	Condition after Interruption	Log in
Screen Change	Current level < Request level	New password screen is displayed	Cancel
	Current level >= Request level	Screen is changed	Cancel
Window Display	Current level < Request level	The password screen remains displayed. If password input is cancelled, the password window screen is displayed immediately.	Password input process continues
	Current level >= Request level	The password screen remains displayed. The window is display in the background.	Password input process continues

- The log-in switch will not function if there is no password setting for the project data.

◆ **Log off**

If you set [Log off] in [Action] of the special switch, you can create a log-off switch for clearing the current security level.

- The current security level can be cleared (= 0) using a log-off switch.  
When the log-off switch is pressed, the screen is changed according to the setting and the current security level and the system variable "H\_LoginUserID" are cleared.
- If a security level is set on the screen after log off, the following behavior will take place.
  - The level of the screen after log off is the same as or lower than the current level  
The screen will be changed and the level will be cleared.
  - The level of the screen after log off is higher than the current level  
Password input screen will be displayed. You cannot log off unless authentication is successful.
- If the base screen of the log off screen number does not exist, only the current security level is cleared. The screen will not be changed.
- Clearing of the system variable "H\_LoginUserID" is the same as the usual level clearing.
- The log-off switch will not function if there is no password setting for the project data.

◆ **Current security level**

The current security level is stored in LS9301 (Security function status). However, you cannot change the values in LS9301 (Read-only).

### ◆ **When operating from GP-Viewer**

As for operation from GP-Viewer, the log-in/log-off switch does not function regardless of Synchronous/Asynchronous Mode. If the log-in/log-off switch is pressed on the GP-Viewer side, an error message is displayed.

---

**NOTE**

- For details, refer to Password Dialog Box Settings Guide in the GP-Viewer EX Operation Manual.
-

## 22.6 Show/Hide Parts/Drawings for a Specific Person to Use.

### 22.6.1 Setup Procedure

Set the security level 5 for the switch and display the hidden switch by entering a password.

**NOTE**

- For more information on Animation feature, please refer to the following.  
☞ Chapter 20 "Animating Screen Objects", page 20-1
  - For details on setting, refer to Animation Settings Guide.  
☞ "20.7 Settings Guide" (page 20-22)
  - For more information on security level setting, refer to the following.  
☞ "22.5 Creating a Screen where Limited Access Parts are Placed" (page 22-13)
- 

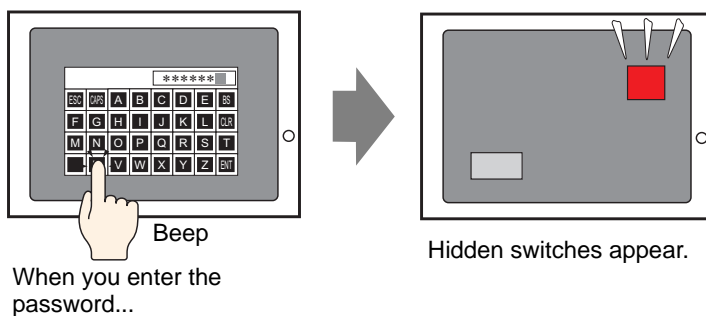

- 1 Select a switch you want to display or hide, and then click [Animation (N)] from the [Edit (E)] menu, or right-click and select [Animation (N)] from the menu displayed.

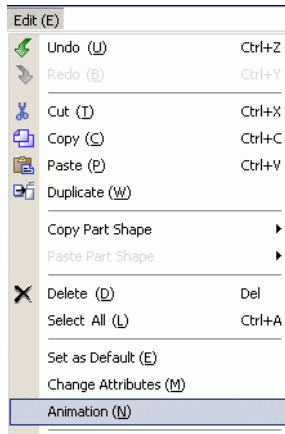

**NOTE**

- Setting screen for animation can also be displayed by clicking [...] of [Animation] in [Properties].

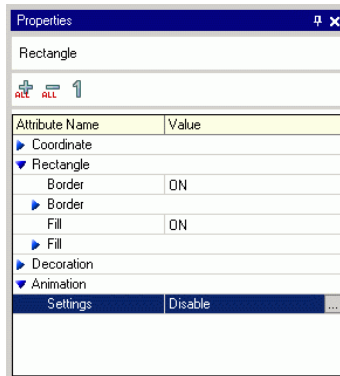

- 2 Setting screen for animation is displayed. Select [Visibility] from the list on the left side of the screen.

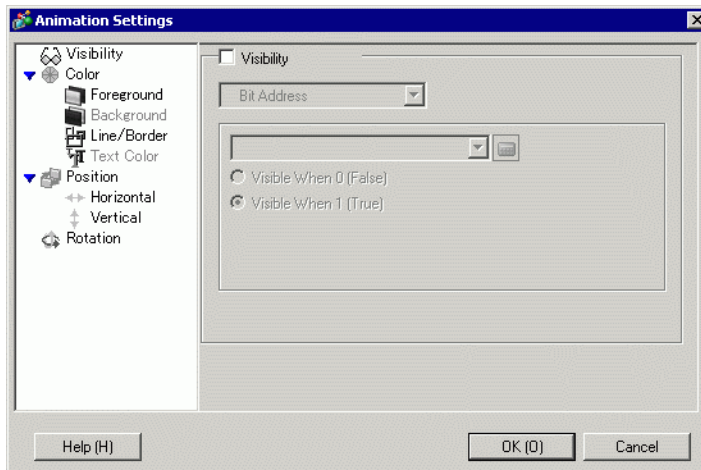



3 Select the [Visibility Animation] check box.

4 Select [Security Level] and set [5] to [Visible when level is greater than or equal to:]. Click [OK].

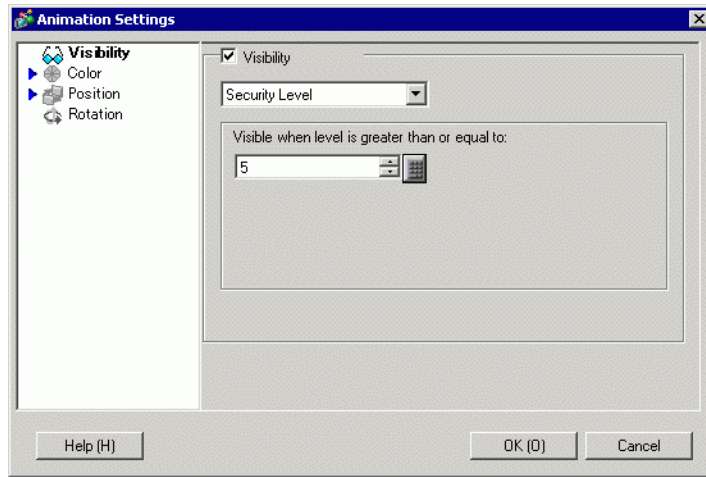

## 22.7 Save Operation History

### 22.7.1 Introduction

Maintaining a history (log) of operations on the GP screen is useful in analyzing causes of problems, such as what operations were run before the error occurred. Also, by setting [User ID] in the Password Settings, you can identify the person operating the system. Normally, the Operation Log, which is stored in SRAM on the GP, is automatically saved for a designated number of entries. You can also save to a designated CF Card or USB Storage by setting the 0 Bit in the control address to ON. When saving, the log is converted to CSV format, so you can view it by using [Show CSV] on the GP screen or on a PC.

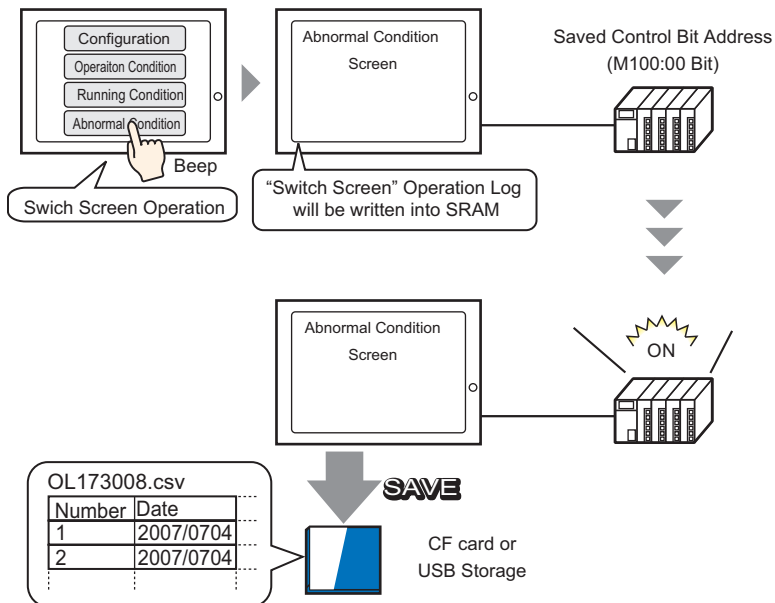

#### NOTE

- To set the User ID, enable [Add User ID] in the [Password Settings] and you will be able to register a User ID.
  - ☞ "22.10.1 Common (Security Settings) Settings Guide ■ Password Settings" (page 22-40)
- Operation Logs that are saved on the CF Card or USB Storage can be displayed on the GP screen by using Special Data Display [File Manager] and [CSV Display].
  - ☞ "25.6 Displaying/Editing CSV data on the Screen" (page 25-29)

## 22.7.2 Setup Procedure

**NOTE**

- Please refer to the Settings Guide for details.  
 ☞ "22.10.2 Common Settings (Operation Log Settings) Guide" (page 22-52)

If Retain Control Bit Address is set to ON, the accumulated Operation Log in the SRAM on the GP is converted to the CSV format, and saved to a CF Card (or USB Storage).

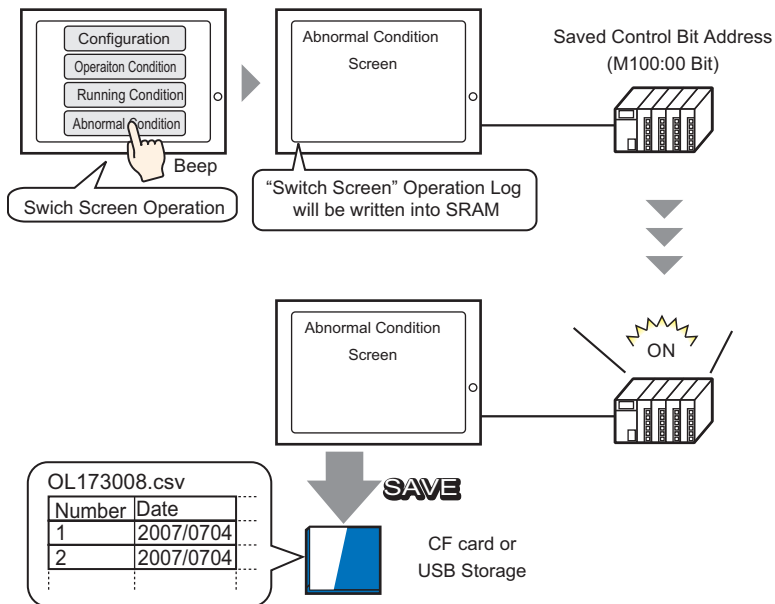

- 1 Select [Operation Log Settings (G)] in the [Common Settings (R)] menu or click the  on the Toolbar.

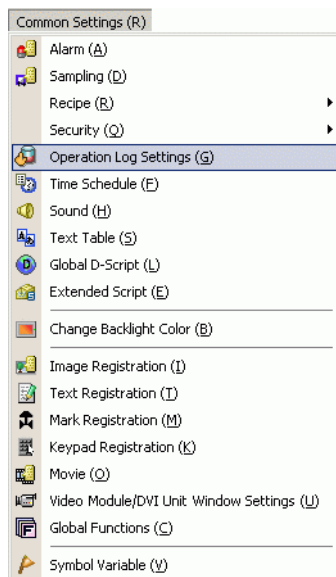

- 2 The Operation Log setting screen opens. Check [Enable Operation Log Function] and select the number of [SRAM Records] to save.

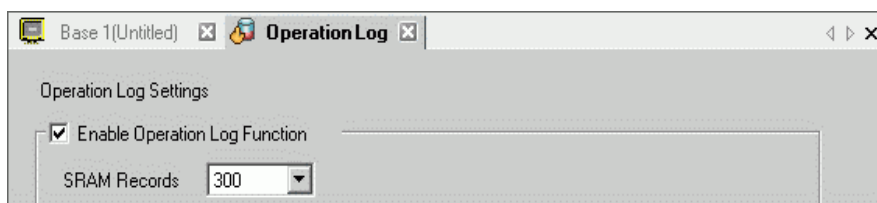
**NOTE**

- The size of SRAM is determined by the selected [SRAM Records]. If the selected number of SRAM records is exceeded, it will be saved to the CF Card (or USB Storage) automatically.

- 3 In [Operations to Log], check the functions that you wish to record in the Operation Log.

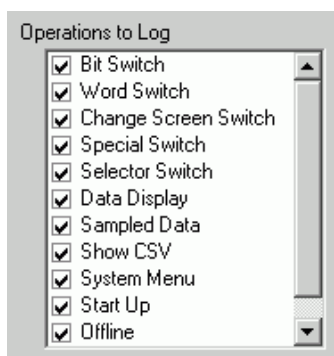
**NOTE**

- Operation log can be recorded for each part. On the setting screen for the part that you want to record the operation log, select the [Include in Operation Log] check box. When setting for each part, on the operation log screen, select the [Enable Operation Log Function] check box. For applicable parts, please refer to the following:  
☞ "22.7.3 Operation Log Settings for Each Part" (page 22-30)

- 4 Select [CF Card] in [Save in].

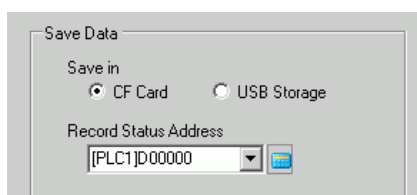

5 Set an address that allows writing to the CF Card (for example, D10) in [Record Status Address].

Click  to display an address input keypad.

Select the device "D" and enter "10" in the address, then press the "Ent" key.

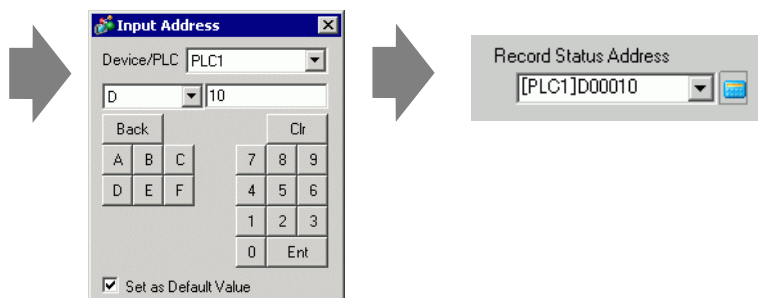

6 [Check [Operation Trigger].

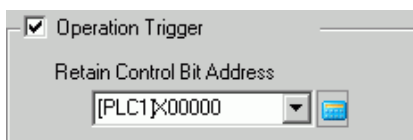

7 In the [Retain Control Bit Address] box, specify the bit address to start saving from (for example, M100).

**NOTE**

- If Bit 1 (Transfer Complete Flag) in the designated Status Address is not set to ON, the Operation Log cannot be saved even if Retain Control Address is ON.

8 Select [Operation when there is insufficient space].

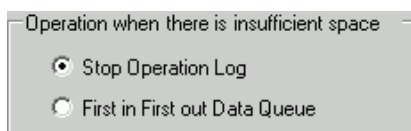

9 In [CSV Format], set [Date], [Time], and Display Style when converting to the CSV Format in [Language].

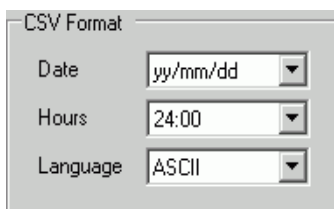

**NOTE**

- "Item Name" in the saved CSV File is displayed in English no matter which language is selected in [Language].

### 22.7.3 Operation Log Settings for Each Part

You can set operation log recording for each part.

Select the [Enable Operation Log Function] check box on the operation log screen, and then select the [Include in Operation Log] check box on the setting screen for the applicable part.

#### ■ Applicable parts

Parts	Action		
Switch/Lamp	Bit Switch		
	Word Switch		
	Screen Change		
	Special Switch	Alarm History Switch	Acknowledge
			Clear
		File Item Switch	Transfer SRAM -> Device/PLC
			Transfer SRAM -> Internal Address
			Transfer Device/PLC -> SRAM
			Transfer Device/PLC -> Internal Address
			Transfer Internal Address -> SRAM
			Transfer Internal Address -> Device/PLC
		Data Transfer Switch	Transfer CF/USB -> Device/PLC
			Transfer Device/PLC -> CF/USB
	Start monitor switch		
	Start application		
	WinGP, exiting		
	Reset		
	Offline		
	Operation Lock		
	Switch for Security		
Switch for Selector List Parts	Confirmed		
Ladder Transfer			
Selector Switch			
Data Display	Numeric Value		
	Text		
Sampled Data			
Special Data Display	Show CSV *2		

## 22.8 Password/User ID Input Window

### 22.8.1 Introduction to "Level Mode" and "User ID Mode"

The password input window/user ID and password input window appears when you access a screen with a security level higher than the one that is currently displayed.

According to the "Password Settings", either "Level Mode" (set password) or "User ID Mode" (set user ID and password) is displayed.

The entered password is displayed as \* symbols.

☞ "22.10.1 Common (Security Settings) Settings Guide ■ Password Settings" (page 22-40)

#### ■ Password/User ID Input Windows

For "Level Mode", only the password input window is displayed.

For "User ID Mode", each window is displayed by touching the input area in the user ID and password input window.

**Password input window**

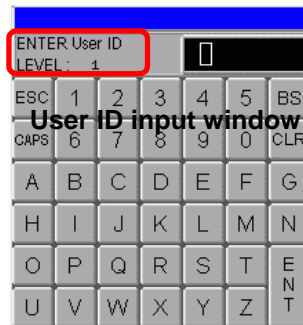
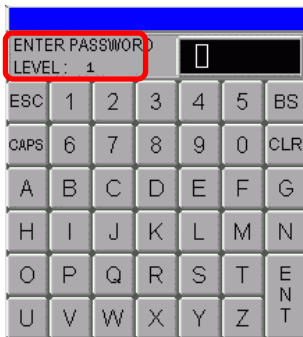

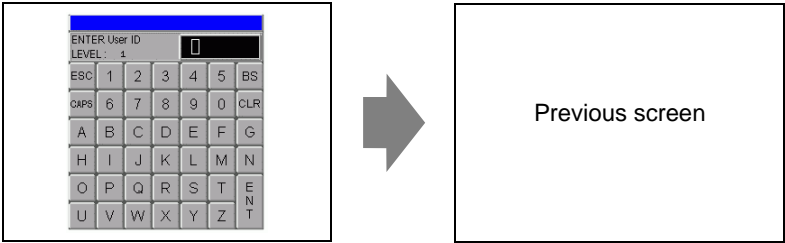
Display	Description
ESC	<p>Cancel the password/user ID input, and close the input window.</p> <div style="text-align: center;">  </div> <p><b>NOTE</b></p> <ul style="list-style-type: none"> <li>When you use both Change Screens by Touch and Change Screens from the device/PLC, confirm that the [Reflect in Device/PLC] option is selected from the System Settings window [Display Unit]-[Display]. If not selected, you cannot cancel even by pressing the [ESC] key when Change Screens from the device/PLC is performed.</li> </ul> <p>☞ 5.17.6 [System Settings] Setting Guide ■ [Display Unit] Settings Guide ◆                      Display Settings •Screen Settings page 5-147</p>

Continued

Display	Description						
CAPS	<p>Changes between uppercase and lowercase letters. When the [CAPS] key is displayed in the reverse color (black), it will input lowercase letters.</p> <p><b>NOTE</b></p> <ul style="list-style-type: none"> <li>• Even if you change between uppercase and lowercase letters, the keypad will only display in uppercase letters.</li> </ul>						
ENT	Secure the input password/user ID.						
LEVEL (Request Level Display)	<p>Shows the security level of the screen you are accessing.</p>  <p><b>NOTE</b></p> <ul style="list-style-type: none"> <li>• The current level and the request level can be seen from the internal device addresses. The values are stored in the following internal device addresses.</li> </ul> <table border="0" data-bbox="436 815 965 877"> <tr> <td>LS9301</td> <td><input type="text"/></td> <td>Current Level</td> </tr> <tr> <td>LS9302</td> <td><input type="text"/></td> <td>Request Level</td> </tr> </table> <p>LS9301 and LS9302 are read-only. When there is a password request in LS9302, the security level is stored and the value returns to 0 when the password input is complete.</p>	LS9301	<input type="text"/>	Current Level	LS9302	<input type="text"/>	Request Level
LS9301	<input type="text"/>	Current Level					
LS9302	<input type="text"/>	Request Level					



■ User ID & Password input window

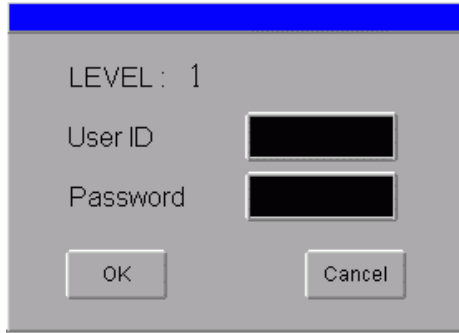

Display	Description						
<p>LEVEL (Request Level Display)</p>	<p>Shows the security level of the screen you are accessing.</p> <p><b>NOTE</b></p> <ul style="list-style-type: none"> <li>The current level and the request level can be seen from the internal device addresses. The values are stored in the following internal device addresses.</li> </ul> <table border="0" style="margin-left: 40px;"> <tr> <td style="padding-right: 10px;">LS9301</td> <td style="border: 1px solid black; width: 150px; height: 15px;"></td> <td style="padding-left: 10px;">Current Level</td> </tr> <tr> <td>LS9302</td> <td style="border: 1px solid black; width: 150px; height: 15px;"></td> <td>Request Level</td> </tr> </table> <p>LS9301 and LS9302 are read-only. In LS9302, if there is a request for the user ID and password, the security level is saved and it will return to 0 when the user ID and password input is completed.</p>	LS9301		Current Level	LS9302		Request Level
LS9301		Current Level					
LS9302		Request Level					
<p>User ID (User ID Input)</p>	<p>Display the User ID Input window by touching the input area. Also, display the User ID input in the User ID Input window.</p>						
<p>Password (Password Input)</p>	<p>Display the password input window by touching the input area. Also, the password entered in the password input window is displayed as * symbols.</p>						
<p>OK</p>	<p>The input User ID and Password are compared with internal records, and if the security level (required level) is satisfied, the screen is displayed.</p> <p><b>NOTE</b></p> <p>Error messages will be displayed in the following situation.</p> <ul style="list-style-type: none"> <li>- Inputting User ID that is not registered</li> <li>- Inputting User ID that does not satisfy the required level</li> <li>- Inputting password that does not match the User ID.</li> </ul>						
<p>Cancel</p>	<p>Close the User ID &amp; Password input window to return to the original screen.</p>						

## 22.9 Editing Password Online

### 22.9.1 Introduction

Prepare a password setting data in CSV format and save it in the CF card or USB storage. Using a special switch for which [Set Password] is set, you can reflect the data by loading the password setting data on the display unit online.

It is possible to edit the password or user ID without putting GP offline.

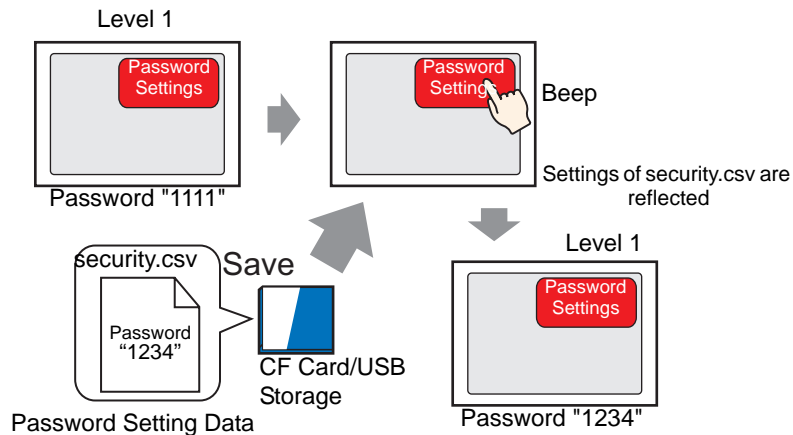
**IMPORTANT**

- As for GP-3300 series, only Rev.4 or later models support this function.

**NOTE**

- Password setting data in CSV format saved on the CF Card or USB Storage can be edited on the GP screen by using Special Data Display [File Manager] and [CSV Display].
  - ☞ "25.6 Displaying/Editing CSV data on the Screen" (page 25-29)
- Password setting data can be handled using system variables instead of special switches.
  - ☞ "A.6.2 HMI system variables (#H system variables) Writing Security Data" (page A-111)
- Password setting data in CSV format can be created by exporting the password setting of GP-Pro EX.
  - ☞ "22.9.3 Creating Password Setting Data" (page 22-38)

## 22.9.2 Setup Procedure

**NOTE**

- For how to set security level to the screen, refer to the following.
  - ☞ "22.3 Limiting Screen Access by Authority" (page 22-8)
- Please refer to the Settings Guide for details on special switches.
  - ☞ "10.15.4 Special Switch ◆ Security" (page 10-77)

A special switch for reflecting the password setting data in CSV format saved on the CF card or USB storage on the display unit.

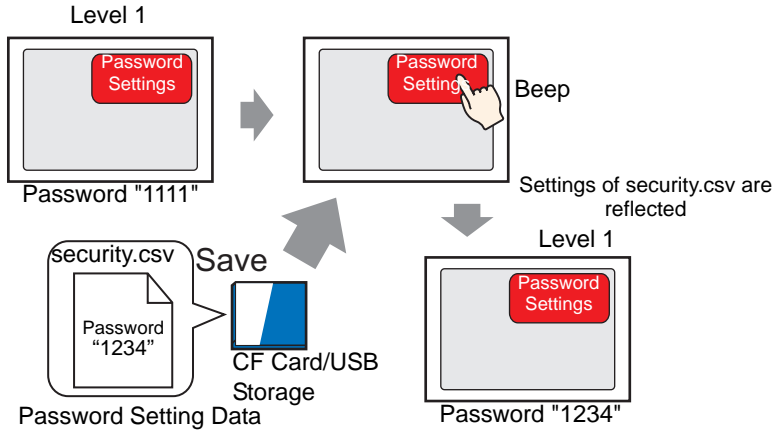

- 1 From the [Parts (P)] menu, point to [Switch/Lamp (C)] and select [Special Switch (P)] or click , and place the Switch on the screen.
- 2 Double-click the placed Switch part. The following dialog box appears.

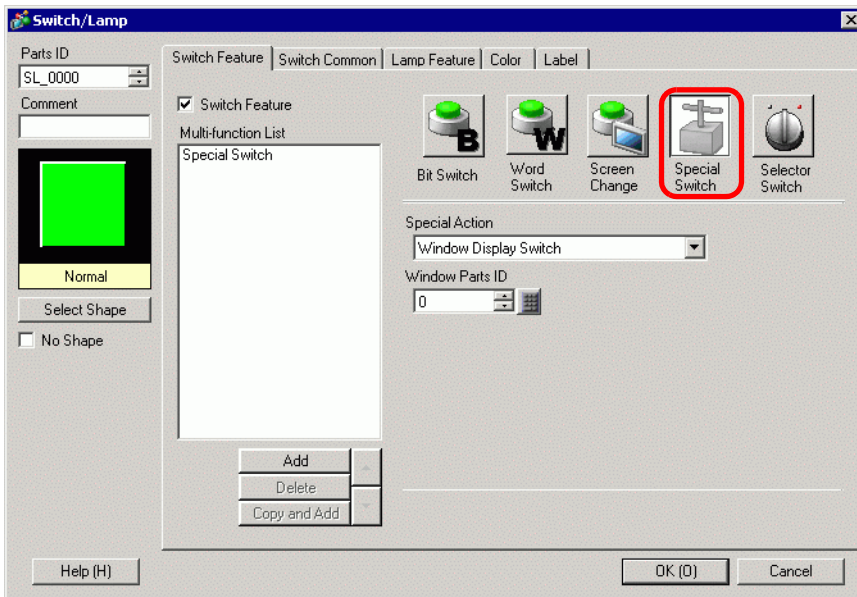

- 3 In [Select Shape], select the Switch shape.

4 Select [Security] in [Special Action].

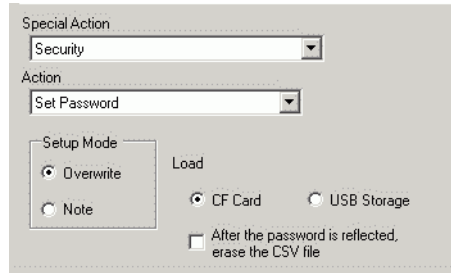

5 In [Action], select [Set Password].

6 From [Setup Mode], select [Overwrite].

**NOTE**

- If you select [Overwrite], only the password of the password setting data can be used after reflecting the password on the display unit. If you select [Append], the existing password and the password of the password setting data can be used after reflecting the password on the display unit.
- If you select the [After the password is reflected, erase the CSV file] check box, the password setting data saved on the external storage will be deleted after reflecting the password on the display unit.  
In order to edit the password again, you need to prepare a password setting data in CSV format.  
Note that the password setting data is not deleted if you failed to reflect the password.

7 Select [CF Card] in [Load].

8 As required, set the color and display text on the [Color] tab and [Label] tab, and click [OK].

**NOTE**

- Depending on the shape, you may not be able to change the color.
- When you select a switch and press the [F2] key, you can directly edit the Label text. When [Text Table] is selected, you can change the Text Table to be displayed.

**■ Action of reflecting (writing) the password setting data to the display unit**

- Using the HMI system variable #H\_SecurityWriteStatus, you can check whether the reflecting action to the display unit is completed successfully.
- If the CF card or USB storage is not inserted, the data cannot be reflected on the display unit, and 0100 (No CF card/USB storage) is stored in the HMI system variable #H\_SecurityWriteStatus.

**NOTE**

- For details on HMI system variables, see "A.6.2 HMI system variables (#H system variables)" (page A-107)

- If the power goes off while writing the password setting data to the display unit, the file may get corrupted.  
In this case, the password setting data cannot be read when starting up the display unit. An error message appears after the startup. In such a scenario, transfer the project again.

## 22.9.3 Creating Password Setting Data

Password setting data in CSV format can be created by exporting the password setting of GP-Pro EX in CSV format.

**NOTE**

- For how to set security level to the screen, refer to the following.
  - ☞ "22.3 Limiting Screen Access by Authority" (page 22-8)
- For details on the password settings, refer to the following.
  - ☞ "22.10.1 Common (Security Settings) Settings Guide" (page 22-40)

1 Create [Password] and [ID] on the password setting screen, and then click [Export].

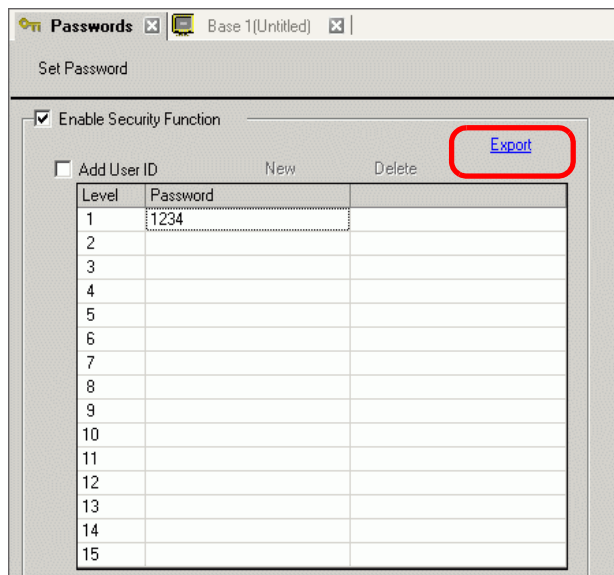

2 The [Export Passwords] dialog box appears. Specify [Destination Folder], and click [Run].

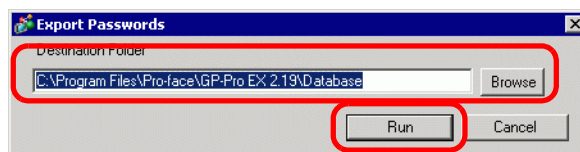
**NOTE**

- Click [Browse] to specify the destination folder on the displayed screen.

3 The [SECURITY] folder is created in the specified location, and the password setting data with the file name "security.csv" is exported in CSV format.

**NOTE**

- Output data differs depending on the "Level Mode" or "User ID Mode" due to the [Add User ID] settings.
- You can also change [Password] and [User ID] on the output "security.csv."

<Level Mode>

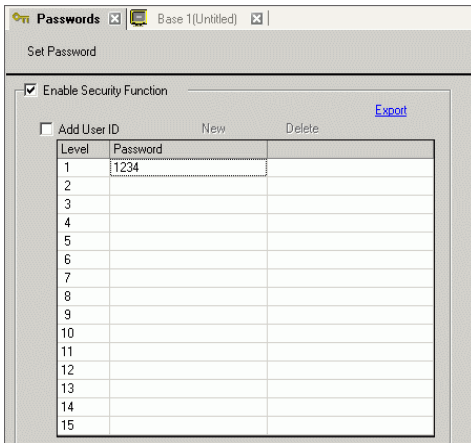

User ID Mode<>

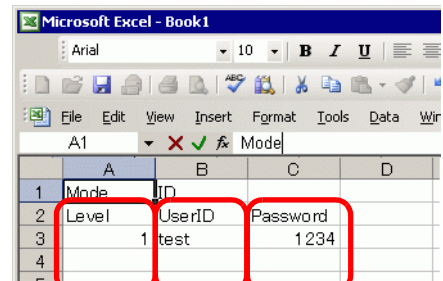
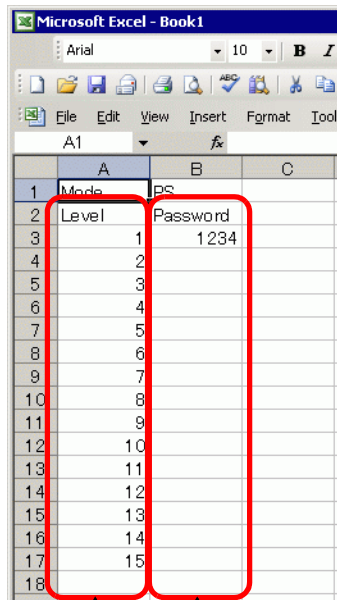
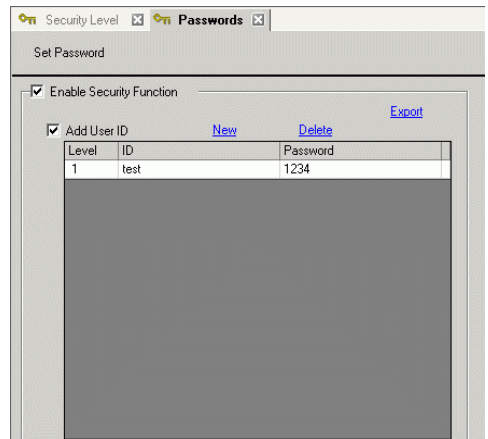

Level ID Password

Level Password

## 22.10 Settings Guide

### 22.10.1 Common (Security Settings) Settings Guide

#### ■ Password Settings

Sets the password and user ID for the 15 security levels.

Depending on the [Add User ID] Settings, either "Level Mode" or "User ID Mode" is displayed.

<Level Mode>

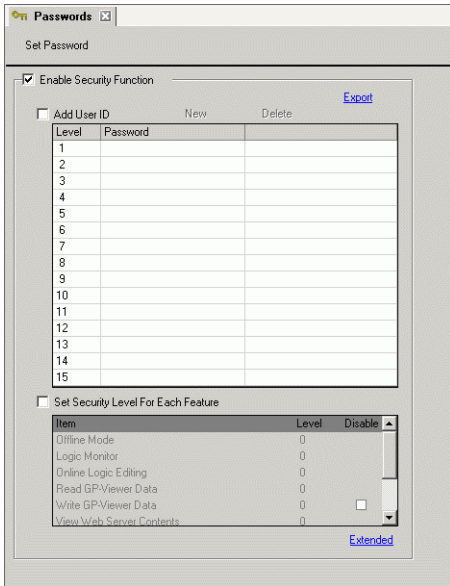

User ID Mode

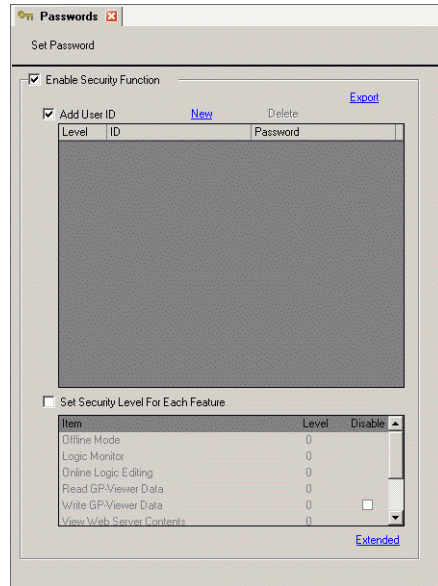



Setting	Description
Enable Security Function	Select to use the security function.
Add User ID	Specifies whether the User ID is added to the level settings.
Level/ Password	<p><b>&lt;For Level Mode&gt;</b></p> <p>Sets password for level 1 to 15. A password can be inputted by using up to eight single-byte characters. Passwords and User ID are case-sensitive. Set passwords only for the security levels you want to use. It is not required to set passwords for all security levels.</p> <p><b>NOTE</b></p> <ul style="list-style-type: none"> <li>When Level Mode is selected, you cannot set the same password for multiple security levels.</li> <li>By setting a password in security level 15, you can change all security level passwords on the GP (offline mode).</li> </ul>

Continued



Setting		Description																						
Add User ID	Level/ Password/ User ID	<p><b>For User ID Mode</b></p> <p>Up to 64 passwords can be registered. You can set the level between 1 to 15 optionally. Up to eight single-byte characters can be used for Password and User ID input. Passwords and User ID are case-sensitive.</p> <p><b>NOTE</b></p> <ul style="list-style-type: none"> <li>• For User ID Mode, you can set the same password for multiple security levels, but you cannot set the same User ID for multiple security levels.</li> <li>• When Level Mode is changed to User ID Mode, only lines that already have passwords can be registered with User ID Mode.</li> </ul> <p><b>IMPORTANT</b></p> <ul style="list-style-type: none"> <li>• If you disable [Add User ID] when it has already been enabled, a message box appears warning that all registered content in the password settings will be deleted if you continue. Selecting "Yes" deletes all the registered content.</li> </ul>																						
	Create New/ Delete	Once [Add User ID] is checked, display of [Create New] and [Delete] is enabled. Select [Create New] to add one line to the registration lines of Password and User ID. [Select [Delete] to delete the line you have selected.																						
Set up function at each security level	Sets whether or not to set functional security settings. Functions that can be set are as follows.																							
	<table border="1"> <thead> <tr> <th>Items</th> <th>Feature</th> </tr> </thead> <tbody> <tr> <td>Changing to Offline Mode</td> <td>Offline Feature</td> </tr> <tr> <td>Logic monitor</td> <td>Logic Feature</td> </tr> <tr> <td>Online Logic Editing</td> <td>Logic Feature</td> </tr> <tr> <td>Read in GP-Viewer Data Values</td> <td>GP-Viewer Function</td> </tr> <tr> <td>Write GP-Viewer Data Values</td> <td>GP-Viewer Function</td> </tr> <tr> <td>Browsing Web Server Contents</td> <td>Web Server Features</td> </tr> <tr> <td>Read in Web Server Data Values</td> <td>Web Server Features</td> </tr> <tr> <td>Write Web Server Data</td> <td>Web Server Features</td> </tr> <tr> <td>Browsing files in the FTP folder</td> <td>FTP Function Set up function at each security level</td> </tr> <tr> <td>Registering and deleting files in the FTP folder</td> <td>FTP Function Set up function at each security level</td> </tr> </tbody> </table>		Items	Feature	Changing to Offline Mode	Offline Feature	Logic monitor	Logic Feature	Online Logic Editing	Logic Feature	Read in GP-Viewer Data Values	GP-Viewer Function	Write GP-Viewer Data Values	GP-Viewer Function	Browsing Web Server Contents	Web Server Features	Read in Web Server Data Values	Web Server Features	Write Web Server Data	Web Server Features	Browsing files in the FTP folder	FTP Function Set up function at each security level	Registering and deleting files in the FTP folder	FTP Function Set up function at each security level
	Items	Feature																						
	Changing to Offline Mode	Offline Feature																						
	Logic monitor	Logic Feature																						
	Online Logic Editing	Logic Feature																						
	Read in GP-Viewer Data Values	GP-Viewer Function																						
	Write GP-Viewer Data Values	GP-Viewer Function																						
	Browsing Web Server Contents	Web Server Features																						
	Read in Web Server Data Values	Web Server Features																						
	Write Web Server Data	Web Server Features																						
	Browsing files in the FTP folder	FTP Function Set up function at each security level																						
Registering and deleting files in the FTP folder	FTP Function Set up function at each security level																							

Continued

Setting	Description
Set up function at each security level  Level	Sets the level for the security settings function. <b>NOTE</b> <ul style="list-style-type: none"> <li>• Security level 0 means no security is set.</li> </ul> <Level 0 or Level 15> Select either Level 0 or Level 15 for "Export error". Level 15 in the password settings is required to set Level 15. Level 15 in the password settings is required to set Level 15. 
	<Level 0 to Level 15> For Logic Function, GP-Viewer Function, Web Server Function, and FTP Function, you can set the security level between 0 to 15. However, the following standards for the level settings apply depending on each function. <ul style="list-style-type: none"> <li>•Logic Monitor and Online Logic Editing                              Only a constant level, or a high Online Logic Editing level, can be set.</li> <li>•Read in GP-Viewer Data Values and Write out GP-Viewer Data Values                              Only a constant level, or a higher level for Write out GP-Viewer Data Values, can be set.</li> <li>•Browsing Web Server Contents, Read in Web Server Data Value and Write out Web Server Data Value                              Only a constant level, or a high level of Write out Web Server Data Values, can be set.</li> <li>•Browsing files in the FTP folder and Register and Delete files in the FTP folder                              Only a constant level, or a higher level for Register and Delete files in the FTP folder, can be set.</li> </ul> When checked, the operation of that function will be disabled regardless of the security level. [Write GP-Viewer EX Data], [Write Web Server Data] or [Save or delete files in FTP folder] can be set.
Extended	Displays the [Extended] dialog box.  " ◆ Extended" (page 22-43)

◆ Extended

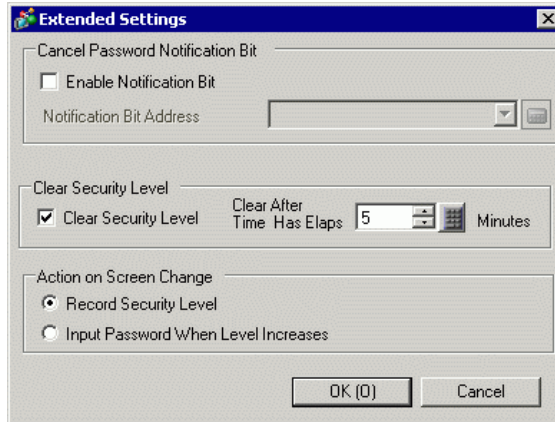

Setting	Description
Enable Notification Bit	Select this check box to send a notification when the ESC key is used to exit the password input window after a change screen operation initiated by the device/PLC. This will not work when changing screens by touch.
Notification Bit Address	When you cancel a password input window displayed via the Device/PLC control with the [ESC] key, the designated Notification Bit Address turns ON. In the System Settings workspace, [Display Unit] screen's [Display] tab, if the [Reflect in Device/PLC] check box is not selected, monitor the notification bit and when it turns ON, on the device/PLC reset the [Change-To Screen No.]*1 to the same number as the [Current Sampled No.].When screen numbers match, the password input window closes.

Continued

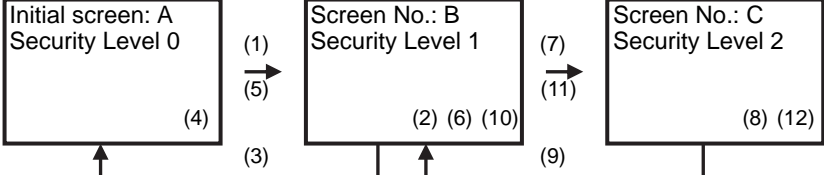
Setting	Description																																																																	
<p>Clear Security Level</p>	<p>This feature specifies whether to return the security level status to "0", assuming no GP unit operations/screen changes are performed within the time specified in [Clear After Time Has Elapsed]. When checked, select either of the following.</p> <ul style="list-style-type: none"> <li>• Record Security Level Once the security level becomes higher, the current level will not be lowered unless it is automatically cleared or cleared with the security control address (LS9300). Therefore, you can change the screen as required.</li> <li>• Input Password When Level Increases When switching the screen to the base screen with a security level lower than the current security level, the level is lowered to the security level of the screen to switch to. Therefore, next time you switch the screen with lower security level to the screen with higher security level, you will require password authentication.</li> </ul> <p>For example:</p>  <table border="1" data-bbox="463 919 1236 1503"> <thead> <tr> <th></th> <th>Record Security Level</th> <th>Current Level</th> <th>Input Password When Level Increases</th> <th>Current Level</th> </tr> </thead> <tbody> <tr> <td>(1)</td> <td>Level 1 Password Screen</td> <td>0</td> <td>Level 1 Password Screen</td> <td>0</td> </tr> <tr> <td>(2)</td> <td>Screen B is displayed</td> <td>1</td> <td>Screen B is displayed</td> <td>1</td> </tr> <tr> <td>(3)</td> <td>No password required</td> <td>1</td> <td>No password required</td> <td>1</td> </tr> <tr> <td>(4)</td> <td>Screen A is displayed</td> <td>1</td> <td>Screen A is displayed</td> <td>0</td> </tr> <tr> <td>(5)</td> <td>No password required</td> <td>1</td> <td>Level 1 Password Screen</td> <td>0</td> </tr> <tr> <td>(6)</td> <td>Screen B is displayed</td> <td>1</td> <td>Screen B is displayed</td> <td>1</td> </tr> <tr> <td>(7)</td> <td>Level 2 Password Screen</td> <td>1</td> <td>Level 2 Password Screen</td> <td>1</td> </tr> <tr> <td>(8)</td> <td>Screen C is displayed</td> <td>2</td> <td>Screen C is displayed</td> <td>2</td> </tr> <tr> <td>(9)</td> <td>No password required</td> <td>2</td> <td>No password required</td> <td>2</td> </tr> <tr> <td>(10)</td> <td>Screen B is displayed</td> <td>2</td> <td>Screen B is displayed</td> <td>1</td> </tr> <tr> <td>(11)</td> <td>No password required</td> <td>2</td> <td>Level 2 Password Screen</td> <td>1</td> </tr> <tr> <td>(12)</td> <td>Screen C is displayed</td> <td>2</td> <td>Screen C is displayed</td> <td>2</td> </tr> </tbody> </table>		Record Security Level	Current Level	Input Password When Level Increases	Current Level	(1)	Level 1 Password Screen	0	Level 1 Password Screen	0	(2)	Screen B is displayed	1	Screen B is displayed	1	(3)	No password required	1	No password required	1	(4)	Screen A is displayed	1	Screen A is displayed	0	(5)	No password required	1	Level 1 Password Screen	0	(6)	Screen B is displayed	1	Screen B is displayed	1	(7)	Level 2 Password Screen	1	Level 2 Password Screen	1	(8)	Screen C is displayed	2	Screen C is displayed	2	(9)	No password required	2	No password required	2	(10)	Screen B is displayed	2	Screen B is displayed	1	(11)	No password required	2	Level 2 Password Screen	1	(12)	Screen C is displayed	2	Screen C is displayed	2
		Record Security Level	Current Level	Input Password When Level Increases	Current Level																																																													
(1)	Level 1 Password Screen	0	Level 1 Password Screen	0																																																														
(2)	Screen B is displayed	1	Screen B is displayed	1																																																														
(3)	No password required	1	No password required	1																																																														
(4)	Screen A is displayed	1	Screen A is displayed	0																																																														
(5)	No password required	1	Level 1 Password Screen	0																																																														
(6)	Screen B is displayed	1	Screen B is displayed	1																																																														
(7)	Level 2 Password Screen	1	Level 2 Password Screen	1																																																														
(8)	Screen C is displayed	2	Screen C is displayed	2																																																														
(9)	No password required	2	No password required	2																																																														
(10)	Screen B is displayed	2	Screen B is displayed	1																																																														
(11)	No password required	2	Level 2 Password Screen	1																																																														
(12)	Screen C is displayed	2	Screen C is displayed	2																																																														

Continued

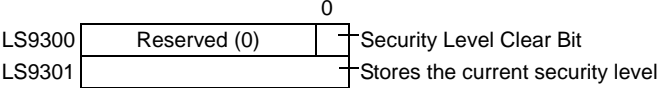
Setting	Description
Clear Security Level	<p><b>NOTE</b></p> <ul style="list-style-type: none"> <li>• This applies only when changing base screens (including sub display screens)</li> <li>• If [Input Password When Level Increases] is selected in User ID Mode, the system variable "#H_LoginUserID" will not be updated when the level is lowered for changing screens.</li> </ul> <p>When using GP-Viewer feature, even if [Input Password When Level Increases] is selected on GP-Viewer side, this will not function. This always operates with [Record Security Level].</p>
Security Level Auto Clear Time	<p>Specify the auto clear time from 1 to 60 minutes.</p> <p><b>NOTE</b></p> <ul style="list-style-type: none"> <li>• Clear by performing the internal device address's bit action When the LS9300's 0 bit goes from OFF -&gt; ON, the security level is cleared and the current security level stored in LS9301 changes to 0. After the Security Level Clear occurs, return LS9300's 0 bit to OFF. (LS9301 is read-only.)</li> </ul> <div style="text-align: center; margin-top: 10px;">  <p style="margin-left: 100px;">0</p> <p>LS9300 <span style="border: 1px solid black; padding: 2px;">Reserved (0)</span>   Security Level Clear Bit</p> <p>LS9301 <span style="border: 1px solid black; padding: 2px;"> </span>   Stores the current security level</p> </div>

\*1 To operate [Change-To Screen Number] via a Device/PLC, please configure the System Data Area.

"5.17.6 [System Settings] Setting Guide ◆ System Area Settings" (page 5-174)

## ■ Security Level List

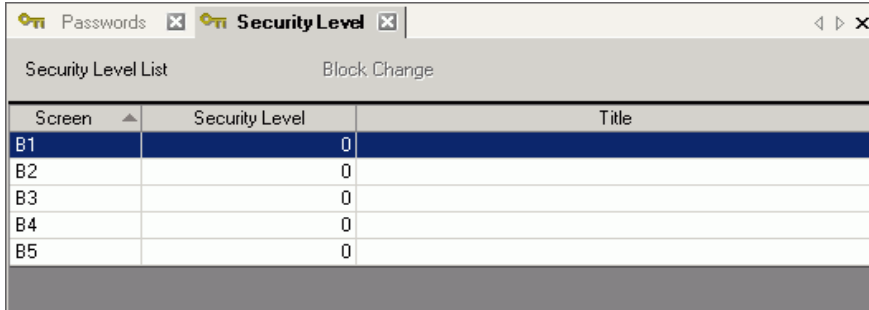

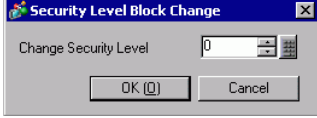
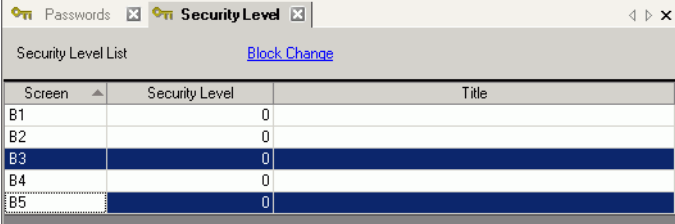
Setting	Description
Screen	Displays the screen number.
Security Level	<p>Set each screen's security level.</p> <p><b>NOTE</b></p> <ul style="list-style-type: none"> <li>When setting multiple screens to the same security level, please use [Block Change].</li> </ul>
Title	Displays each screen's title.
Block Change	<p>Updates the selected security levels for multiple screens at one time. Select the screens to change and click [Block Change]. The Security Level Block Change dialog box appears and allows you to change the level.</p>  <p><b>NOTE</b></p> <ul style="list-style-type: none"> <li>To select multiple screens, drag the cursor or select rows while holding down the [CTRL] key.</li> </ul> 

## ■ Interlock Settings

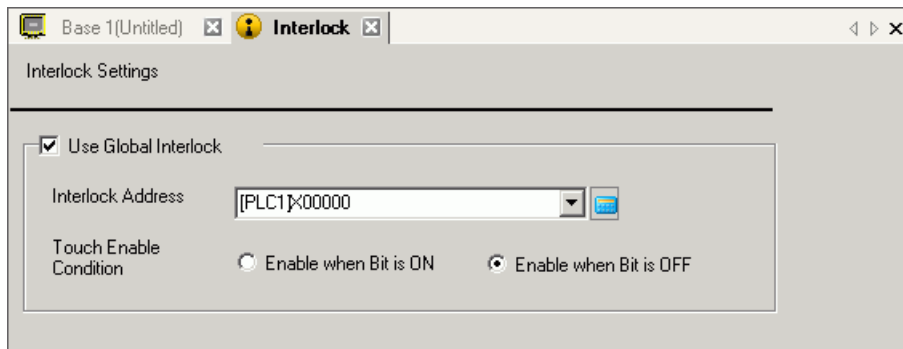

Setting	Description													
Use Global Interlock	<p>Sets whether to use Global Interlock or not</p> <p><b>NOTE</b></p> <ul style="list-style-type: none"> <li>This function only allows touch operation when a bit designated via [Interlock Address] is in a state that has been specified by [Touch Enable Condition].</li> </ul>													
Interlock Address	<p>Specifies the bit address (all bit addresses can be set) that represents an Enable condition for allowing touch input. Touch is enabled (disabled) depending on the state of this address.</p>													
Touch Enable Condition	<p>Select the condition that will enable the part to be touched, to allow input to be entered.</p> <table border="1"> <thead> <tr> <th>Touch Enable Condition</th> <th>Interlock Address Status</th> <th>Touch Enabled/ Disabled</th> </tr> </thead> <tbody> <tr> <td rowspan="2">Enable when Bit is ON</td> <td>ON</td> <td>Touch enabled</td> </tr> <tr> <td>OFF</td> <td>Touch disabled</td> </tr> <tr> <td rowspan="2">Enable when Bit is OFF</td> <td>ON</td> <td>Touch disabled</td> </tr> <tr> <td>OFF</td> <td>Touch enabled</td> </tr> </tbody> </table>	Touch Enable Condition	Interlock Address Status	Touch Enabled/ Disabled	Enable when Bit is ON	ON	Touch enabled	OFF	Touch disabled	Enable when Bit is OFF	ON	Touch disabled	OFF	Touch enabled
Touch Enable Condition	Interlock Address Status	Touch Enabled/ Disabled												
Enable when Bit is ON	ON	Touch enabled												
	OFF	Touch disabled												
Enable when Bit is OFF	ON	Touch disabled												
	OFF	Touch enabled												

■ **Global Interlock's Touch Enable Condition**

Enable / Disable of touch varies depending on the state of the settings of parts used in the same project or the state of the connection with the external Device/PLC. This section explains Enable / Disable of touch for each setting.

◆ **Simultaneous use of parts with interlock**

The Interlock installed on individual parts and global interlock can be used simultaneously, but when simultaneously used, the global interlock will take priority.

For example, even if the interlock for the individual parts is released, touch is disabled for that part if it is in a state of global interlock.

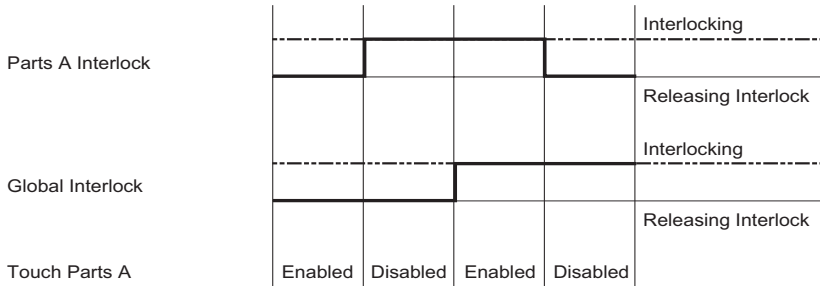

◆ **Specifies the address of the external Device/PLC**

When the address of the external Device/PLC is designated as the global interlock address, Touch Enable Condition cannot be determined until the connection with that Device/PLC is established. Therefore, regardless of [Enable when Bit is ON]/[Enable when Bit is OFF], the global interlock will be enabled.



However, if disconnected once a connection is established, the status will be the same as prior to disconnection.

- Touch Enable Condition: Enable when Bit is ON

Communication Status of Devices/PLC	Not Connected	Connected	Not Connected	Connected	Connected	Not Connected	Connected	Bit ON
Interlock Address								
Touch propriety	Disabled	Enabled	Enabled	Enabled	Disabled	Disabled	Disabled	Bit OFF

Communication Status of Devices/PLC	Not Connected	Connected	Not Connected	Connected	Connected	Not Connected	Connected	Bit ON
Interlock Address								
Touch propriety	Disabled	Disabled	Disabled	Disabled	Enabled	Enabled	Enabled	Bit OFF

- Touch Enable Condition: Enable when Bit is OFF

Communication Status of Devices/PLC	Not Connected	Connected	Not Connected	Connected	Connected	Not Connected	Connected	Bit ON
Interlock Address								
Touch propriety	Disabled	Disabled	Disabled	Disabled	Enabled	Enabled	Enabled	Bit OFF

Communication Status of Devices/PLC	Not Connected	Connected	Not Connected	Connected	Connected	Not Connected	Connected	Bit ON
Interlock Address								
Touch propriety	Disabled	Enabled	Enabled	Enabled	Disabled	Disabled	Disabled	Bit OFF

**NOTE**

- Even in the case of multiple PLC Connections, as long as a connection is established with a PLC where an address is allocated in the global interlock, the global interlock operates regardless of whether the connection with other PLCs has been established or not.
- Display settings for each part that indicates the state of the Interlock can be applied to the interlock condition for that part. It cannot be applied to the state of global interlock.

◆ **Parts settings that allow group function with Delay or Auto OFF**

When entering a state of global interlock (touch is disabled) during the operation of the parts, touch can be enabled until the operation of the parts is completed or touch can be disabled throughout operation.

- Group function with OFF Delay and Auto OFF

When the parts that allow the group function with OFF Delay and Auto OFF is changed to a Global Interlock Condition (touch is disabled) during a momentary operation, the momentary operation takes priority during Delay or Auto OFF. It will not enter the state of global interlock (touch is disabled) until the Delay is completed or the auto OFF setting period has elapsed.

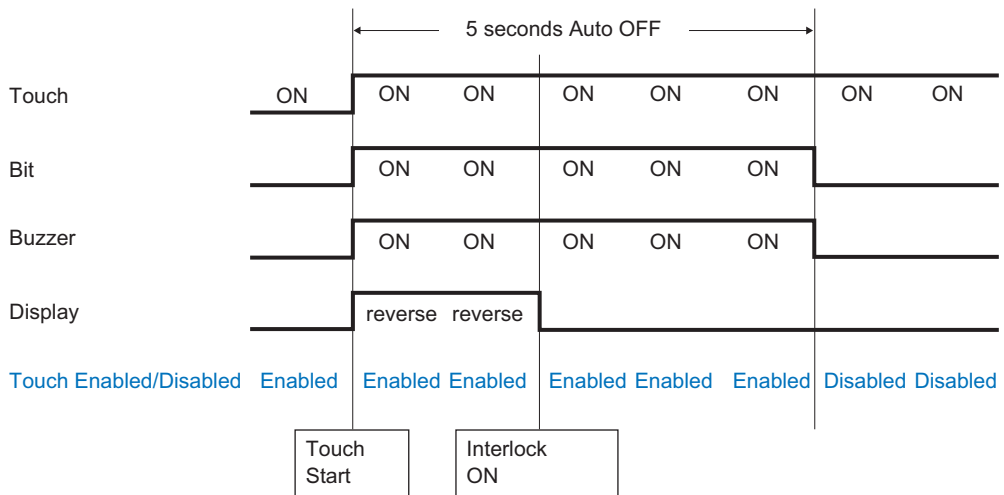
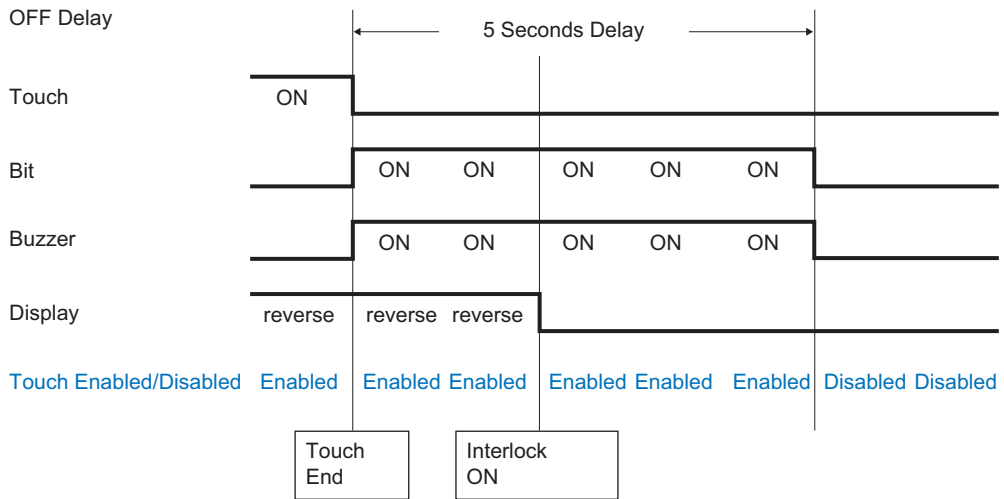

Before Auto-Off elapses, and you release the touch, touch becomes Disabled from that point.

- ON Delay, 2 Points Pressing Delay Function

For ON Delay and 2 Points Pressing Delay Function, if the condition is changed to the Global Interlock Condition (touch is disabled) during the Delay, the delay is canceled, and the Global Interlock Condition (touch is disabled) is activated.

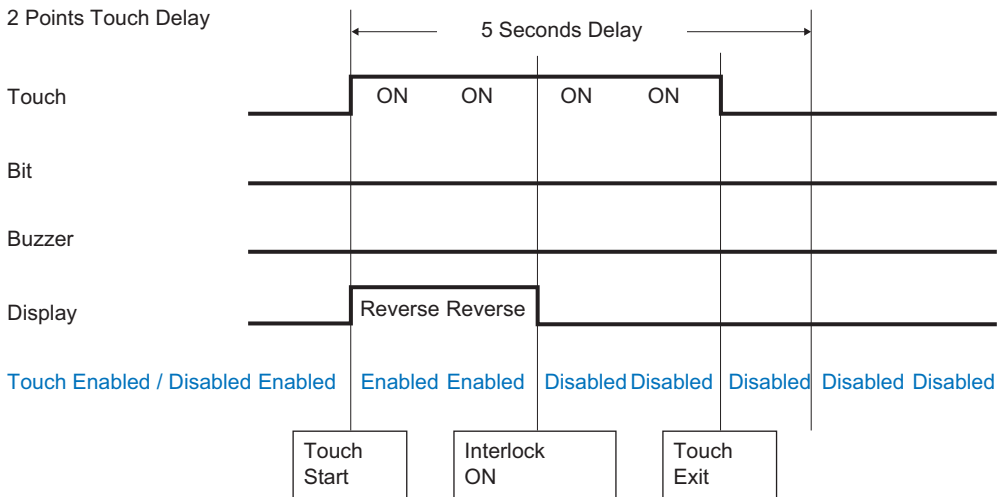
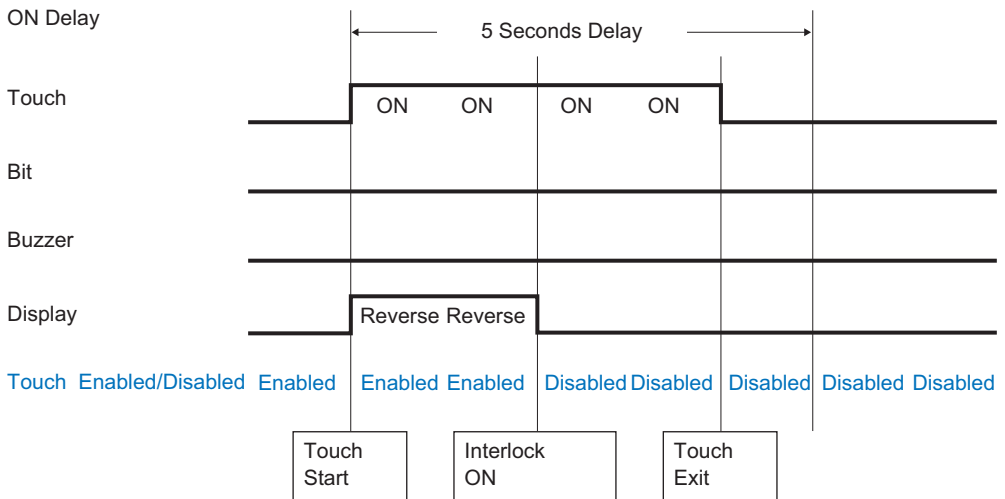

## 22.10.2 Common Settings (Operation Log Settings) Guide

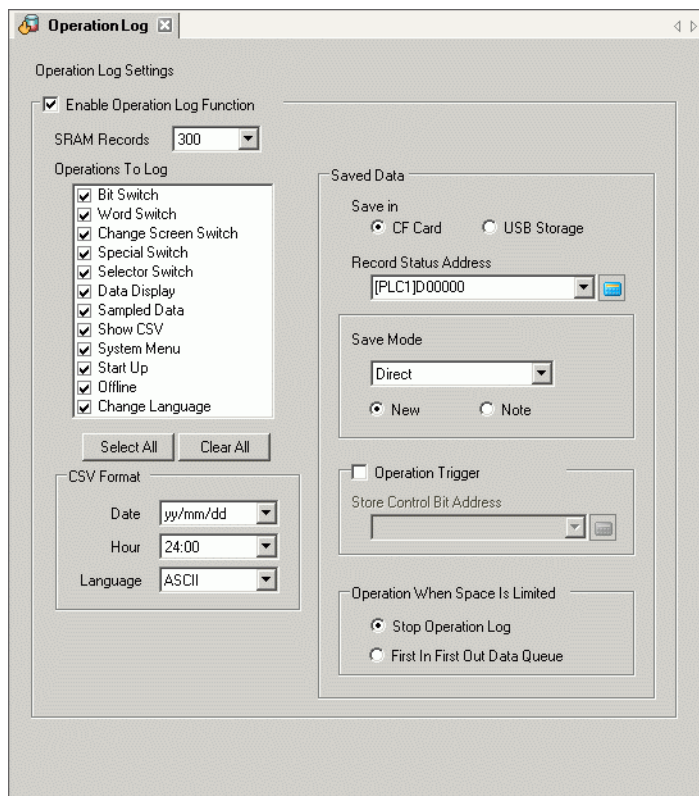

Setting		Description
Enable Operation Log Function		Specifies whether to use the Operation Log feature or not
SRAM Records		Select a number to save to SRAM from 100, 200, 300, 400 and 500. <b>NOTE</b> <ul style="list-style-type: none"> <li>The capacity of the SRAM in GP is determined by the number of entries selected.</li> </ul>
Operations to Log		Select the functions for Operations to Log from [Bit Switch], [Word Switch], [Change Screen Switch], [Special Switch], [Selector Switch], [Data Display], [Sampling Data Display], [Show CSV], [System Menu], [Start], [Offline], and [Change Language]. <b>NOTE</b> <ul style="list-style-type: none"> <li>In Initialization Settings, all of the functions are targeted as Operations to Log.</li> </ul>
Saved Data	Save in	Select [CF Card] or [USB Storage] as the "Save in" location when outputting the Operation Log by converting to CSV format, or when exceeding the number of entries to save in the SRAM

Continued

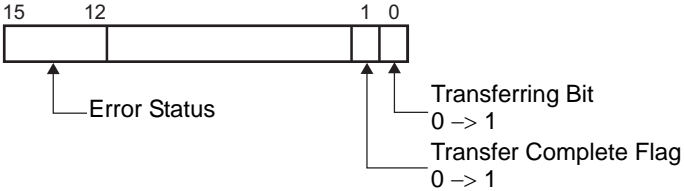
Setting	Description															
Saved Data	<p>Specifies the address for confirming the condition of writing in to CF Card or USB Storage.</p> <ul style="list-style-type: none"> <li>• Status Once Bit 0 in the [Control] Address is set to ON, Bit 0 in the [Status] Address is turned ON. After confirming the condition of the [Control] address, Bit should be turned ON in the [Status] address to write in.</li> </ul> <div style="text-align: center;">  <p style="margin-left: 100px;">Error Status</p> <p style="margin-left: 200px;">Transferring Bit 0 → 1</p> <p style="margin-left: 200px;">Transfer Complete Flag 0 → 1</p> </div> <p>The error status indicates the following conditions. (Error Code)</p> <table border="1" data-bbox="399 668 1249 1045"> <thead> <tr> <th>Bit 12 to 15</th> <th>Description</th> <th>Introduction</th> </tr> </thead> <tbody> <tr> <td>0000</td> <td>Completed Successfully</td> <td>When the backup process is completed successfully.</td> </tr> <tr> <td>0100</td> <td>CF Card/No USB storage</td> <td>Occurs during backup if the CF Card/USB storage is not inserted or if the CF Card hatch is open.</td> </tr> <tr> <td>0101</td> <td>CF Card/USB storage write error</td> <td>There is not enough storage capacity in the CF Card/USB storage during backup, or CF Card/USB storage is removed during writing.</td> </tr> <tr> <td>0111</td> <td>CF Card/USB storage error</td> <td>CF Card/USB storage is not formatted or some other error</td> </tr> </tbody> </table>	Bit 12 to 15	Description	Introduction	0000	Completed Successfully	When the backup process is completed successfully.	0100	CF Card/No USB storage	Occurs during backup if the CF Card/USB storage is not inserted or if the CF Card hatch is open.	0101	CF Card/USB storage write error	There is not enough storage capacity in the CF Card/USB storage during backup, or CF Card/USB storage is removed during writing.	0111	CF Card/USB storage error	CF Card/USB storage is not formatted or some other error
	Bit 12 to 15	Description	Introduction													
	0000	Completed Successfully	When the backup process is completed successfully.													
	0100	CF Card/No USB storage	Occurs during backup if the CF Card/USB storage is not inserted or if the CF Card hatch is open.													
0101	CF Card/USB storage write error	There is not enough storage capacity in the CF Card/USB storage during backup, or CF Card/USB storage is removed during writing.														
0111	CF Card/USB storage error	CF Card/USB storage is not formatted or some other error														
Save Mode	<p>Sets actions when saving operation logs.</p> <ul style="list-style-type: none"> <li>• Direct When [New] is selected, a new CSV file will be created. When [Append] is selected, data is added to the existing CSV file.</li> <li>• Address Specifies an address to change the action for saving data. When the bit 0 of the specified address turns ON, [New] is selected, and when the bit 1 turns ON, [Append] is selected.</li> </ul> <p><b>NOTE</b></p> <ul style="list-style-type: none"> <li>• The number of data that can be added is up to 10000 for one CSV file.</li> </ul>															
Operation Trigger	Specifies whether or not to save at a specified timing when you want to save the operation log at a given timing.															
Retain Control Bit Address	Turn ON the designated Bit to start writing in the CF Card or USB storage.															

Continued

Setting		Description
Saved Data	Operation when space is limited	<p>Specifies the operation when there is not enough space in the CF Card or USB storage.</p> <ul style="list-style-type: none"> <li>• Stop Operation Log Stop outputting to the file of the operation log at the "Save in" location. When the next operation is conducted, recording of the operation log completely stops, and nothing is recorded.</li> <li>• First in First out Data Queue Delete the oldest file that is saved in the CF Card or USB storage, and save the data in the SRAM.</li> </ul>
	CSV Format	Set the Display Format when saving in CSV format.
	Date	Select the display format for dates, from mm/dd/yy (month/day/year), mm/dd (month/day), yy/mm/dd (year/month/day/), dd/mm/yy (day/month/year).
	Time	Select the display format for time, from 12:00 or 24:00.
	Language	Select the language format from Japanese, languages that support ASCII, Chinese (Traditional), Chinese (Simplified), Korean, Cyrillic, and Thai.

## ■ Operation Log

### ◆ Type and content of obtained data

The functions that are recorded in the log as information about touch operation are as follows.

Feature	Action	Action
Bit Switch	Bit Set	Bit Set
	Bit Reset	Bit Rst
	Bit Momentary	Bit Mom
	Bit Invert	Bit Rvs
	Comparison	Bit Comp
Word Switch	Word Write in	Word Write
	Word Add	Word Add
	Word Continuous Add	Word Add++
	Word Sub	Word Sub
	Word Continuous Sub	Word Sub--
	Digit Addition	Digit Add
	Digit Continuous Add	Digit Add++
	Digit Subtraction	Digit Sub
	Digit Continuous Sub	Digit Sub--
	Scripts	Word Ope
Change Screen Switch	Previous Screen	Scrn Prev
	Screen Change	Scrn Chg

Continued

Feature	Action		Action
Special Switch	Alarm History Switch	Acknowledge	Alm Ack
		Clear	Alm Clr
	File Item Switch	Transfer SRAM -> Device/PLC	SRAM->PLC
		Transfer SRAM-> Internal Address	SRAM->ADDR
		Transfer Device/PLC -> SRAM	PLC->SRAM
		Transfer Device/PLC -> Internal Address	PLC->ADDR
		Transfer Internal Address->SRAM	ADDR->SRAM
		Transfer Internal Address -> Device/PLC	ADDR->PLC
	Data Transfer Switch	Transfer External storage -> Device/PLC	Ex Mem -> PLC
		Transfer Device/PLC -> External storage	PLC -> Ex Mem
Special Switch	Start monitor switch	Ladder Monitor	Bit Set
		Ladder Monitor (Cache)	
		Device Monitor	Bit Set
	Start application		App ON
	WinGP, exiting		Win End
	Reset		Reset
	Offline		Offline
	Operation Lock	Lock and Unlock	Ope LockRel
		Lock	Ope Lock
		Remove forces	Ope Release
Selector Switch			Bit Slet
Data Display	Touch, Input Barcode (Edit Data)		Data Input
Sampled Data	Sampling Data Display (Edit Data)		Samp Input

Continued



<b>Feature</b>	<b>Action</b>	<b>Action</b>
Show CSV	Show CSV (Edit Data)	CSV Input
System Menu	Offline	Offline
	Reset	Reset
	Address Monitor	Addr Mon
	Logic monitor	Logi Mon
	Ladder Monitor	Lad Mon
	Device Monitor	Dev Mon
	CF Start	CF Start
	USB Start	USB Start
Startup	Main body Start	Power ON
	Trans Ret	Trans Ret
Offline	Off Chg	OFF Chg
	Off Ret	OFF Ret
Change Language	Language Change	Lang Chg

## Example of CSV File Output

Number	Date	Time	User ID	LEVEL	Screen	Parts ID	Comment	Action	Address
1	07/12/22	13:54		0	b1	SL_0001		Bit Set	[PLC1]M0000
2	07/12/22	13:54		0	b1	SL_0002		Bit Rst	[PLC1]M0001
3	07/12/22	13:55	YAMADA	3	b1	SL_0003	Level 3 Switch	Bit Mom	

## &lt;Item and Summary&gt;

Items	Description
Number	Log number
Date	Operation data is displayed in the format that is set in [Operation Log Settings].
Time	Operation time is displayed in the format that is set in [Operation Log Settings].
User ID	User ID that is registered in "User ID Mode" (Add User ID) is displayed. For "Level Mode" (Do not add User ID), this will be blank.
Level	Display the level between 0 to 15 at the time of operation.
Screen	Displays the Screen Number in B** for the Base Screen, and in W** for the Window Screen at the time of operation.
Parts ID	Displays Parts ID.
Comment	Displays comments in Parts. If nothing is registered, this will be blank.
Action	Displays Action ☞ " ◆ Type and content of obtained data" (page 22-55)
Address	Displays a target address
Sub Info	This will be displayed when supplemental remarks are needed regarding Address or Action.
Prev Value	Displays the previous value.
Chg Value	Displays the changed value. Bit Address displays ON or OFF and Word Address displays a numeric value. The display format of the numeric value differs depends on the display attributes of the parts being used.

**NOTE**

- "Number" is addressed sequentially in the file.
- The item names are fixed in English.

◆ Contents of the functional operation log

<Bit Switch>

Target: Bit Set, Bit Reset, Bit Momentary, Bit Invert, Comparison

**NOTE**

- Please refer to the Settings Guide for details.  
 "10.15.1 Bit Switch" (page 10-51)

Items	Description
Number	Common items  " <Item and Summary>" (page 22-58)
Date	
Time	
User ID	
Level	
Screen	
Parts ID	
Comment	
Action	
Address	
Sub Info	Bit Set : Hidden Bit Reset : Hidden Bit Momentary : Hidden Bit Invert : Hidden Comparison : Displays a Comparison Word Address and a Constant of Comparison Condition <Example> [PLC1]D0001 (space) < (space) 10 Comparison Word Address     Comparison Condition   Constant
Prev Value	Hidden
Chg Value	Bit Set : ON Bit Reset : OFF Bit Momentary : (When pressing) ON (When releasing) OFF As for Bit Momentary, the log is obtained separately for ON and for OFF. Bit Invert : Hidden Comparison : ON or OFF

<Word Switch>

Target: Word Write, Word Add, Word Continuous Add, Word Subtract, Word Continuous Subtract, Digit Addition, Digit Continuous Add, Digit Subtraction, Digit Continuous Subtraction, Operation

**NOTE**

- Please refer to the Settings Guide for details.  
 "10.15.2 Word Switch" (page 10-65)

Items	Description
Number	Common items  " <Item and Summary>" (page 22-58)
Date	
Time	
User ID	
Level	
Screen	
Parts ID	
Comment	
Action	
Address	Displays a target address External device address:[PLC1]*****, [# MEMLINK]***** Symbol : Operation Start Variable : Run Start System Variable : #H*****, #L*****

Continued

Items	Description
Sub Info	<p>Word Write in : Hidden</p> <p>Word Add Constant : Displays the base Word Address for Add + Constant</p> <p>Word Sub Constant : Displays the base Word Address for Sub - Constant</p> <p>Digit Addition : Displays the Digit Position</p> <p>Digit Subtraction : Displays the Digit Position</p> <p>Operation : Displays the base Word Address for Operation and the Constant For example: [PLC1]D0001 (space) AND (space) 10 (Operation Base Word Address Operator Constant)</p> <p>Word Continuous Add : Displays the base Word Address for Add, the Constant, and ON/OFF.</p> <p>Word Continuous Sub : Displays the base Word Address for Sub, the Constant, and ON/OFF.</p> <p>Digit Continuous Add : When pressed Digit Position ON When released Digit Position OFF</p> <p>Digit Continuous Sub : When pressed Digit Position ON When released Digit Position OFF</p> <p> "10.15.2 Word Switch ◆ Scripts" (page 10-68)</p>
Prev Value	Hidden
Chg Value	<p>Word Write in, Digit Addition, Digit Continuous Add, Digit Subtraction, Digit Continuous Sub: Displays Write in value</p> <p>Word Add, Word Continuous Add, Word Sub, Word Continuous Sub, Operation: Hidden</p>

<Change Screen Switch>

Target: Previous Screen, Screen Change

**NOTE**

- Please refer to the Settings Guide for details.  
 "10.15.3 Change Screen Switch" (page 10-69)

Items	Description
Number	Common items  " <Item and Summary>" (page 22-58)
Date	
Time	
User ID	
Level	
Screen	
Parts ID	
Comment	
Action	
Address	
Sub Info	Hidden
Prev Value	Previous Screen: Displays the screen number before changing Screen Change: Displays the screen number before changing
Chg Value	Previous Screen: Displays the changed screen number (if there is no previous screen, 0 will be displayed) Screen Change: Displays the changed screen number

<Special Switch (Alarm)>

Target: Acknowledged, Clear

**NOTE**

- Please refer to the Settings Guide for details.  
 "10.15.4 Special Switch ◆ Alarm History Switch" (page 10-73)

Items	Description
Number	Common items  " <Item and Summary>" (page 22-58)
Date	
Time	
User ID	
Level	
Screen	
Parts ID	
Comment	
Action	
Address	
Sub Info	Displayed depending on the Action. Alarm History Acknowledged (Acknowledged) : Ack Alarm History Acknowledged (Ack All) : Ack All Alarm History Clear (Clear) : Clr Alarm History Clear (Clear All) : Clr All Alarm History Clear (Clear Recovery Alarm) : Clr Rcv Alarm History Clear (Clear Acknowledged Alarm): Clr Ack Alarm History Clear (Clear All Recovery Alarm): Clr All Rcv Alarm History Clear (Clear All Acknowledged Alarm): Clr All Ack Alarm History Clear (Clear All Count) : Clr All Cnt Alarm History Clear (Clear One Count) : Clr One Cnt Alarm History Clear (Clear All Time) : Clr All Time Alarm History Clear (Clear One Time) : Clr One Time
Prev Value	Hidden
Chg Value	Hidden

<Special Switch (File Item Switch)>

Target: Transfer SRAM -> Device/PLC, Transfer SRAM -> Internal Address, Transfer Device/PLC -> SRAM, Transfer Device/PLC -> Internal Address, Transfer Internal Address -> SRAM, Transfer Internal Address -> Device/PLC

**NOTE**

- Please refer to the Settings Guide for details.  
 "10.15.4 Special Switch ◆ File Item Switch" (page 10-78)

Items	Description
Number	Common items  " <Item and Summary>" (page 22-58)
Date	
Time	
User ID	
Level	
Screen	
Parts ID	
Comment	
Action	
Address	
Sub Info	Transfer SRAM -> Device/PLC: Example File Number (space) Item Name (space) Storage Start Address Transfer SRAM -> Internal Address: Example File Number (space) Item Name (space) Storage Start Address Transfer Device/PLC -> SRAM: <Example> File Number (space) Item Name (space) Storage Start Address Transfer Device/PLC -> Internal Address: <Example> File Number (space) Item Name (space) Storage Start Address Transfer Internal Address -> SRAM: <Example> File Number (space) Item Name (space) Storage Start Address Transfer Internal Address -> Device/PLC: <Example> File Number (space) Item Name (space) Storage Start Address
Prev Value	Hidden
Chg Value	Hidden



<Special Switch (Data Transfer Switch)>

Target: Transfer CF -> Device/PLC, Transfer Device/PLC -> CF, Transfer USB -> Device/PLC, Transfer Device/PLC -> USB

**NOTE**

- Please refer to the Settings Guide for details.  
 "10.15.4 Special Switch ◆ Data Transfer Switch" (page 10-79)

Items	Description
Number	Common items  " <Item and Summary>" (page 22-58)
Date	
Time	
User ID	
Level	
Screen	
Parts ID	
Comment	
Action	
Address	
Sub Info	CF Card->CF USB Storage -> USB
Prev Value	Hidden
Chg Value	Hidden

<Special Switch (Start monitor switch)>

Target: Ladder Monitor, Ladder Monitor (cache), Device Monitor

**NOTE**

- Please refer to the Settings Guide for details.  
 "10.15.4 Special Switch ◆ Start Monitor Switch" (page 10-83)

Items	Description
Number	Common items  " <Item and Summary>" (page 22-58)
Date	
Time	
User ID	
Level	
Screen	
Parts ID	
Comment	
Action	

Continued

Items	Description
Address	Displays a target address
Sub Info	Hidden
Prev Value	Hidden
Chg Value	ON

<Special Switch (Security)>

Target: Password Setting, Log in, Log off

**NOTE**

- Please refer to the Settings Guide for details.  
 "10.15.4 Special Switch ◆ Security" (page 10-77)

Items	Description
Number	Common items  " <Item and Summary>" (page 22-58)
Date	
Time	
User ID	
Level	
Screen	
Parts ID	
Comment	
Action	Password Settings: Pass Chg Log in : Logon Log off : Logoff
Address	Hidden
Sub Info	Password Settings : Overwrite All Add       Add Log in : Hidden Log off : Hidden
Prev Value	Hidden
Chg Value	Password Settings: Hidden Log in : Hidden Log off : Change To Screen Number (Hidden when screen change is not applicable)

## &lt;Special Switch (Operation Lock)&gt;

Target: Password Setting, Log in, Log off

Items	Description
Number	Common items ☞ " <Item and Summary>" (page 22-58)
Date	
Time	
User ID	
Level	
Screen	
Parts ID	
Comment	
Action	Lock and Unlock: Ope LockRel Lock : Ope Lock Unlock : Ope Release
Address	Hidden
Sub Info	Automatic Unlock: Auto Release No Automatic Unlock: Hidden *Always hidden when Action is Unlock
Prev Value	Hidden
Chg Value	Hidden

## &lt;Special Switch (Switch for Selector List)&gt;

Target: Switch for determining sub-parts

Items	Description
Number	Common items ☞ " <Item and Summary>" (page 22-58)
Date	
Time	
User ID	
Level	
Screen	
Parts ID	
Comment	
Action	SlctList On - Action of functioned switch Example: Bit Set SlctList On - Bit Set
Address	Address of functioned switch
Sub Info	Sub Info of functioned switch
Prev Value	Prev Value of functioned switch
Chg Value	Chg Value of functioned switch

<Special Switch (Transfer Device/PLC Data)>

Target: Password Setting, Log in, Log off

Items	Description
Number	Common items ☞ " <Item and Summary>" (page 22-58)
Date	
Time	
User ID	
Level	
Screen	
Parts ID	
Comment	
Action	
Address	Lad Trans
Sub Info	Hidden
Prev Value	Hidden
Chg Value	Hidden

<Special Switch (Others)>

Target: Start Application, Exit WinGP, Reset, Offline

**NOTE**

- Please refer to the Settings Guide for details.  
 "10.15.4 Special Switch ■ Switch Feature" (page 10-70)

Items	Description
Number	Common items  " <Item and Summary>" (page 22-58)
Date	
Time	
User ID	
Level	
Screen	
Parts ID	
Comment	
Action	
Address	
Sub Info	Start Application : Displays the name of the EXE executed. End of the EXE path, the following text is displayed.
	Exit WinGP : Hidden
	Reset : Hidden
	Offline : Hidden
Prev Value	Hidden
Chg Value	Hidden

<Selector Switch>

**NOTE**

- Please refer to the Settings Guide for details.  
 "10.15.5 Selector Switch" (page 10-86)

Items	Description
Number	Common items  " <Item and Summary>" (page 22-58)
Date	
Time	
User ID	
Level	
Screen	
Parts ID	
Comment	
Action	

Continued

Items	Description
Address	Displays a target address External device address:[PLC1]*****, [# MEMLINK]***** Symbol : Operation Start Variable : Run Start System Variable : #H*****, #L*****
Sub Info	Hidden
Prev Value	Hidden
Chg Value	ON

<Data Display>

Target: Input of numeric values or characters, and Barcode Input, when using the Data Display with a Touch Input or Barcode Input function

Items	Description
Number	Common items  " <Item and Summary>" (page 22-58)
Date	
Time	
User ID	
Level	
Screen	
Parts ID	
Comment	
Action	
Address	
Sub Info	Hidden
Prev Value	Touch Input : Displays the numeric value or text before input is confirmed, using up to 100 characters. Barcode Input : Displays the previous bar code value, using up to 100 characters. <div style="border: 1px solid black; padding: 2px; width: fit-content; margin: 5px 0;"><b>NOTE</b></div> <ul style="list-style-type: none"> <li>The Operation Log for the previous value only is not obtained when input confirmation has not been carried out.</li> </ul>
Chg Value	Touch Input : Displays the numeric value or text after input is confirmed, using up to 100 characters. Input Barcode : Displays the value from bar code input, using up to 100 characters.

\*1 When the Address Type is [Address], the displayed address is the actual display target address ([Base address] + [Offset address]).

<Sampling Data Display (Edit Data)>

Target: When data is edited with the Sampling Data Display

Items	Description
Number	Common items ☞ " <Item and Summary>" (page 22-58)
Date	
Time	
User ID	
Level	
Screen	
Parts ID	
Comment	
Action	
Address	
Sub Info	Hidden
Prev Value	Hidden
Chg Value	Hidden

CSV Display (Edit Data)

Target: When data is edited with the CSV Display

Items	Description
Number	Common items ☞ " <Item and Summary>" (page 22-58)
Date	
Time	
User ID	
Level	
Screen	
Parts ID	
Comment	
Action	
Address	
Sub Info	Hidden
Prev Value	Hidden
Chg Value	Hidden



<System Menu>

Target: Offline, Reset, Address Monitor, Logic Monitor, Ladder Monitor, Device Monitor, CF Start, USB Start

Items	Description
Number	Common items ☞ " <Item and Summary>" (page 22-58)
Date	
Time	
User ID	
Level	
Screen	Hidden
Parts ID	Hidden
Comment	Hidden
Action	Common items ☞ " <Item and Summary>" (page 22-58)
Address	Hidden
Sub Info	Hidden
Prev Value	Hidden
Chg Value	Hidden

## &lt;Startup&gt;

Target: Startup display unit, startup via transfer

Items	Description
Number	Common items ☞ " <Item and Summary>" (page 22-58)
Date	
Time	
User ID	Hidden
Level	Hidden
Screen	Hidden
Parts ID	Hidden
Comment	Hidden
Action	Common items ☞ " <Item and Summary>" (page 22-58)
Address	Hidden
Sub Info	Hidden
Prev Value	Hidden
Chg Value	Hidden

**NOTE**

- Not recorded in the Operation Log when data is transmitted from the transmission screen of the Project File on the offline menu.

## &lt;Offline&gt;

Target: offline transition (the right-click menu in the WinGP is included), recovery from offline

Items	Description
Number	Common items ☞ " <Item and Summary>" (page 22-58)
Date	
Time	
User ID	
Level	Offline transition : Displays the level during operation Recovery from offline : Displays the 0
Screen	Hidden
Parts ID	Hidden
Comment	Hidden
Action	Common items ☞ " <Item and Summary>" (page 22-58)
Address	Hidden

Continued

Items	Description
Sub Info	Table name
Prev Value	Hidden
Chg Value	Hidden

## &lt;Change Language&gt;

Target: Change Language

Items	Description
Number	Common items ☞ " <Item and Summary>" (page 22-58)
Date	
Time	
User ID	
Level	
Screen	Hidden
Parts ID	Hidden
Comment	Hidden
Action	Common items ☞ " <Item and Summary>" (page 22-58)
Address	Hidden
Sub Info	Displays the table name with 30 characters or less.
Prev Value	Hidden
Chg Value	Hidden

## ◆ Recording Timing of the Operation Log

Recording timing of the operation log differs depending on the target features to be recorded.

**NOTE**

- Regarding offline operation, the operation log recording starts from the time of the move to online mode. The log is not recorded when offline.

### <Basic Switch Action>

The previous value is not recorded.

- **Bit Switch**  
The operation log is recorded only for the state after the change.  
Example: When "ON" is changed to "OFF", only the log for "OFF" is saved.
- **Word Switch**  
The operation log is recorded only for the state after the change.  
Example: When "100" is changed to "200", only the data of "200" is saved.

### When [Touch Panel Detection] is [ON Detection]

**NOTE**

- See the settings guide for the settings details of [Touch Panel Detection].  
☞ "5.17.6 [System Settings] Setting Guide ◆ Operation" (page 5-151)

- When the switch action is normal (common for all switches)  
The log recording is performed by turning the switch to ON. For Momentary, data value recording is performed when the state is either ON or OFF.

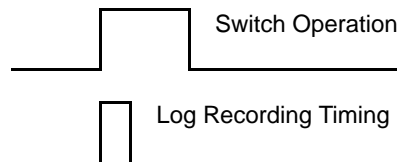

- When ON Delay or OFF Delay is set  
The operation log recording starts after the delay time has passed.
- When Double Touch is set  
The operation log recording starts when the double touch is enabled.

When [Touch Panel Detection] is [OFF Detection]

- When the switch action is normal (common for all switches)  
Log recording is performed by turning the switch OFF. Only values after the change are saved are logged.

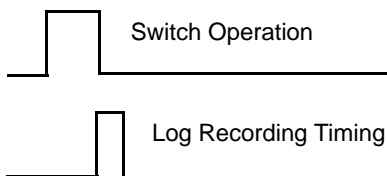

- When Double Touch is set  
The operation log recording is performed when the switch is pressed for the second time.

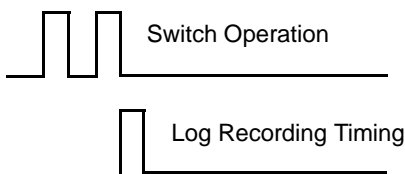

<Data Display>

The previous value is recorded at the time when Allow Data Input is triggered, and the data for the changed value is recorded at the time when Input is fixed.

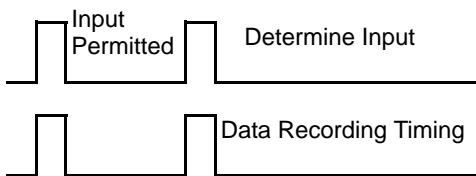

The previous value is recorded when Input Permitted is triggered. If a cancel is performed after that, the data of the previous value is discarded without performing the operation log recording.

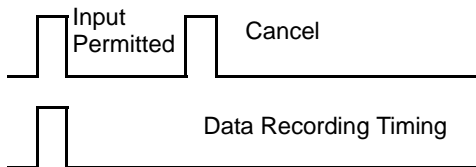



## 22.11 Restrictions

### 22.11.1 Restrictions on Passwords and IDs

- The User ID and Password Input Window, the Password Input Window, and the User ID Input Window cannot be edited.
- A Password or a User ID cannot be entered from the Device/PLC.
- A Password or a User ID cannot be entered from the Bar Code Reader.
- When the Password Input Window (the User ID Input Window) or the User ID and Password Input Window is displayed, if the Trigger Bit of the Local Window or the Global Window is turned ON, close the Password Input Window (the User ID Input Window) or the User ID and Password Input Window and then display.
- Do not set [Continuous Read] for Window Parts to call the Window Screens setting Security Level. The Password Input Window or the User ID and Password Input Window is not displayed on the GP even if you set it, and the security feature does not run.
- When the security level registering no Password is set for the screen, the screen can not be displayed unless you input a Password or a User ID and Password with the greater security level than the screen.

When a Password or a User ID and Password with a greater security level than the screen you want to display have/has not been registered, you can not change screens.

Example 1: When the passwords are set as follows and the screen changes to a level 4 screen

Level 1	AAAA
Level 2	BBBB
Level 3	CCCC
Level 4 to 14	None
Level 15	ZZZZ

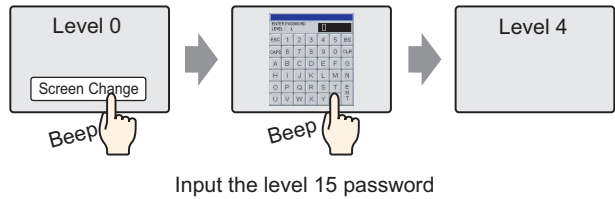

There is a password higher than level 4, so the screen change is permitted.

Example 2: When the passwords are set as follows and the screen changes to a level 4 screen

Level 1	AAAA
Level 2	BBBB
Level 3	CCCC
Level 4 to 15	None

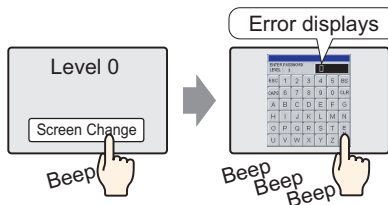

Even if you have inputted something, pressing the [ESC] key will return to the previous screen.

There is no password higher than level 4, so the screen change is not permitted.

- In the "Level Mode" (Do Not Add a User ID), an error does not occur even though a Password has not determined. However, an error occurs when you set the same Password. In the "User ID Mode" (Add a User ID), a Password has to be set. The same Password can be set. However, when no User ID is determined or a User ID is duplicated, an error occurs and settings are not completed.
- When the security level is set for the screen displayed at the beginning after turning on the GP Power (the initial screen), the initial screen is displayed and followed by the Password Input Window or the user ID and Password Input Window. Therefore, the initial screen is running while the Password Input Window or the user ID and Password Input Window is displayed. In addition, the Password Input Window displayed here cannot be canceled by the [ESC] key, and the user ID and Password Input Window cannot be canceled by the [Cancel] key. It is necessary to input the correct Password or the user ID and Password.

---

### 22.11.2 Restrictions on the global interlock

---

- During the global interlock, Touch Operations on the screen are disabled. However, it is possible to perform Touch Operations for the following features, in the same way as normal.
  - Displaying and operating the System Menu
  - Displaying and operating the Brightness/Contrast adjustment bar
  - Changing the Error Window (single-line <=> details) and deleting it
  - Returning from standby mode (Screen OFF)
  - Operating Offline
- If the features or parts are touched when touching them has been disabled by the global interlock, the touch buzzer sound does not sound, and AUX is not output.
- During the global interlock, do not activate the Ladder Monitor, the Device Monitor, the Logic Monitor, or the Address Monitor. If you activate them, you cannot exit any monitor feature because touch operation is disabled.

---

### 22.11.3 Restrictions on the operation log

---

- Do not turn off the power or remove the CF Card or USB memory during the save operation to the CF Card or USB Storage. Data may not be saved normally.
- If the file size is greater than the remaining capacity in the CF Card or USB Storage, the file can not be saved.
- An operation log which has been recorded on SRAM during Project Transfer is saved in the CF Card or USB Storage.  
However, if the CF Card or USB Storage can not be found on the GP or the remaining capacity is not enough, the data of the operation log is deleted. When the project is transferred from the transfer screen for project files on the offline menu, the operation log is not saved in the CF Card or USB Storage.
- When you add data to the existing CSV file, up to instances of 10,000 data can be added to the newest operation log file. When the total number of the data of the existing file and the added file exceeds 10,000 instances, create a new CSV file instead of adding data.
- The operation log does not record the action of simulation.



- The operation log does not record data when the project is transferred from the transfer screen for project files on the offline menu.
- Even if the execution condition of the operation log is set to "When Bit is ON", when the capacity of SRAM is filled up, data is automatically output to the CF Card or USB Storage as a CSV file.
- A log operated remotely using the GP-Viewer can not be saved.
- The IPC Series do not have Backup SRAM. Therefore, the History Data is backed up periodically. Backup is performed in the designated frequency or trigger, so the operation log after the last backup is not saved if the power is turned off before backup. Recording of the operation log will be restarted after recovery.

Refer to the following for the settings of the destination to save the History Data in the IPC Series.

☞ "38.10.1 System Settings [Display Unit Settings] [IPC Settings] Settings Guide ■ Historical Data Retentive Settings" (page 38-166)

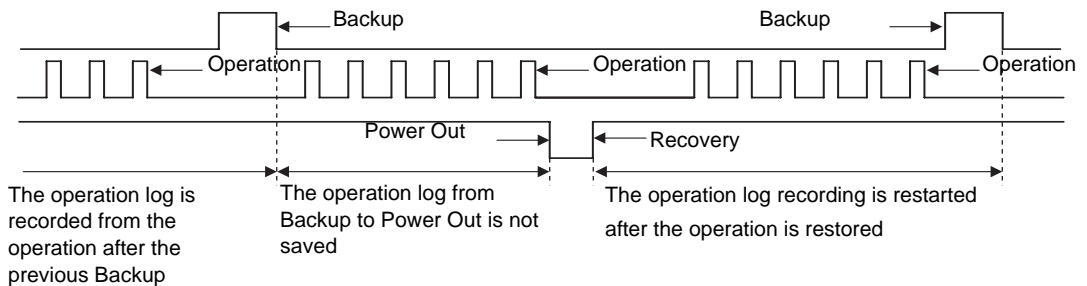

### 22.11.4 Restrictions when setting a security level for each part

- If the log-in switch and log-off switch are overlapped with each other, only one of the two can function when touched. This also applies in the case where the log-in switch and Change Screen switch are overlapped. Do not overlap the two switches.

## 22.11.5 Restrictions when Editing Password Online

- Password will be required if the security setting is enabled for the following features.

Features That Support Security	Conditions for Security
Changing to Offline Mode	When changing to offline
Logic monitor	When starting the logic monitor on GP
Online Logic Editing	When starting the monitor from GP-Pro EX
Read GP-Viewer Data	When connecting GP-Viewer to GP
Write GP-Viewer Data	When writing data from GP-Viewer (Touching switch parts, etc.)
View Web Server Contents	When connecting Web Server to GP
Read Web Server Data	When a Web Server device view is selected When a Web Server alarm is selected
Write Web Server Data	When writing values in the specified address in Web Server device view
Review files in an FTP folder	When Web Server file transfer is selected
Save or delete files in a FTP folder	When trying to register/delete files through Web via file transfer

After the changed password is reflected, the new password can be used.

Once you enter the password (log in), you do not need to enter a password afterwards, except as follows:

- For View Web Server Contents, Read Web Server Data and Write Web Server Data, once you enter the password on the Server, you are recognized as having logged in. Therefore, you do not have to enter the password.  
However, even when you have logged in, authentication is required for security every time you view an HTML page and it is confirmed that the current Web Server log-in data exists in the display unit. Therefore, if the log-in data has been changed or deleted with the password change feature, authentication error occurs when viewing an HTML page and password will be required.  
In this case, enter new password to log in again.  
(This occurs in both ID mode and PS mode.)
- Logic monitor  
A password will be required every time, independently of GP-Pro EX settings.
- If the user ID data of the current user has been changed or deleted, the internally held user ID is deleted and the current security level is changed to 0.
- If the password required for screen change and the like has been deleted, it becomes impossible to function without the security. However, if the set password has a level equal to or higher than the required level, that password can be used.