

Appendix

In this appendix,

"A.1 Communication" introduces the SIO type for connecting the GP and the device/PLC and the structure of the internal device.

"A.2 Monitoring the Value of Device Addresses (Device Monitor)" explains the feature for monitoring the communication device on the GP.

"A.3 Executing Multiple Actions (Programs) with a Switch Operation" explains Trigger Action Parts.

"A.4 Drawing in Other Languages" explains the process from preparing to input a foreign language to inputting the switch label, using (Simplified) Chinese as an example.

"A.5 Transferring Data Between a CF Card and a USB Memory Device" explains how to transfer data between a CF Card and a USB memory device using File Manager.

"A.6 System Variables" provides a detailed explanation of the system variables available in GP-Pro EX.

A.1	Communication	A-2
A.2	Monitoring the Value of Device Addresses (Device Monitor)	A-46
A.3	Executing Multiple Actions (Programs) with a Switch Operation	A-59
A.4	Drawing in Other Languages	A-74
A.5	Transferring Data Between a CF Card and a USB Memory Device	A-82
A.6	System Variables	A-88

A.1 Communication

NOTE

- For information on the connection methods for the GP and device/PLC, refer to the GP-Pro EX Device/PLC Connection Manual.

A.1.1 Settings Menu

Communicating with a Device/PLC Using the Direct Access Method

This is useful when connecting to a device/PLC that is supported by the GP.

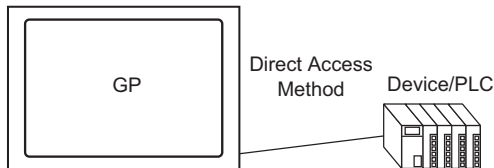

- ☞ Setup Procedure (page A-4)
- ☞ Introduction (page A-4)

Using the Memory Link Method with Unsupported Devices/PLCs

Create an extended script to output data read from a barcode connected to the USB to a serial printer connected to COM1.

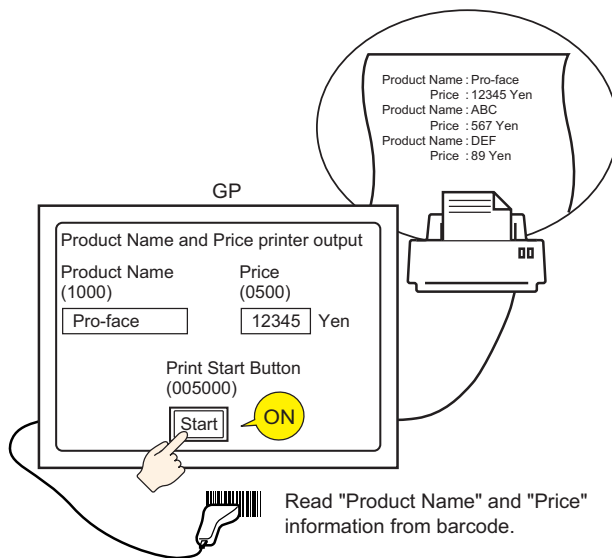

- ☞ Setup Procedure (page 21-34)
- ☞ Introduction (page 21-21)

Using the Memory Link Method with Unsupported Devices/PLCs

Create and execute all programs needed to communicate on the device/PLC side (computer, microprocessor board) with the Memory Link Method.

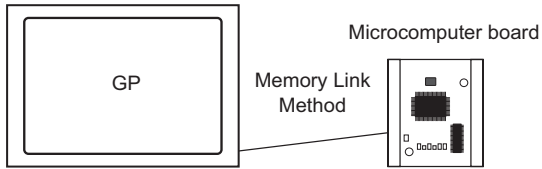

- ☞ Setup Procedure (page A-6)
- ☞ Introduction (page A-6)

A.1.2 Communicating with a Device/PLC Using the Direct Access Method

A.1.2.1 Introduction

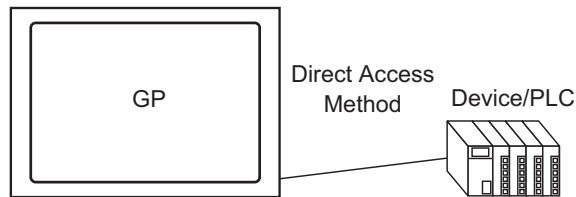

To communicate with a device/PLC, use the Direct Access communication method to reduce the burden on the device/PLC.

■ Direct Access Method

In the Direct Access Method, the GP makes a request to the device/PLC. The device/PLC then responds to the request from the GP.

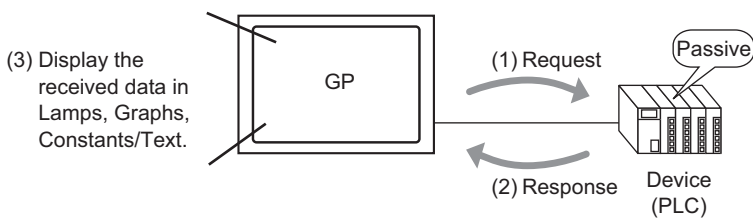

◆ Usable Addresses

For the GP to get the necessary display data from the device/PLC, set an address that can reference data used for Parts and script features. There are two types of addresses which can be set as reference destinations.

- Device/PLC Addresses

The GP can reference the device/PLC data.

Select the device/PLC name (for example, "PLC1") that will communicate with the GP, and input that address (for example, "D00000").

For example, an Input Address screen on a Word Switch.

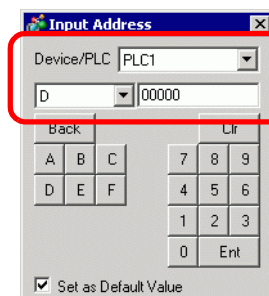

- GP Internal Device Address

This can be used for data storage. For example, this can be used when temporarily storing calculated values inside the GP, or when temporarily controlling data in the GP. When referencing that data, select [#INTERNAL] as the [Device/PLC], and input that address. [#INTERNAL] refers to the GP internal device.

For example, an Input Address screen on a Word Switch.

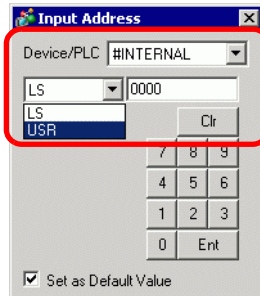

The GP's internal device [#INTERNAL], has two structured areas: the [LS] area and the [USR] are (shown below).

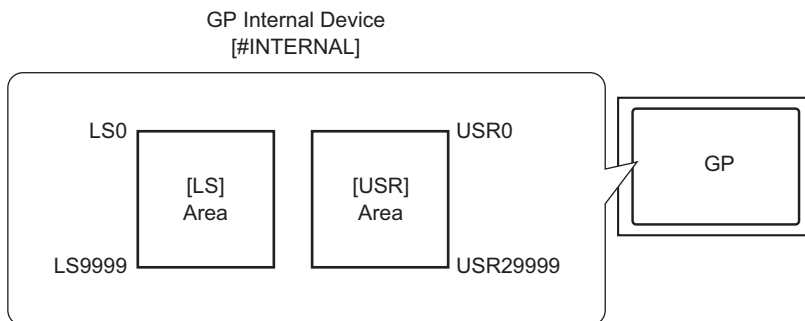

- [LS] Area

This contains free user areas and an area for operating the GP.

☞ "A.1.4 LS Area (Direct Access Method)" (page A-8)

You can change the data storage order in the System Settings window's [Device/PLC] page, with the [Text Data Mode] property.

☞ " ■ [Device/PLC] Settings Guide" (page 5-181)

You can also change the data storage order by defining the text data mode using address LS9310.

☞ " ◆ Data Storage Mode" (page 21-118)

- [USR] Area

You may use all areas as you like, up to 30,000 Words.

The data storage order is fixed to L/H, no matter what the [Text Data Mode] property is set to in the System Settings window's [Device/PLC] page.

☞ "A.1.6.4 Restrictions when Using the USR Area" (page A-45)

◆ **Device Codes of GP Internal Devices (LS/USR)**

Device	Device Code	Address Range
LS	0x0000	0 - 9999
USR	0x0001	0 - 29999

A.1.3 Using the Memory Link Method with Unsupported Devices/PLCs

A.1.3.1 Introduction

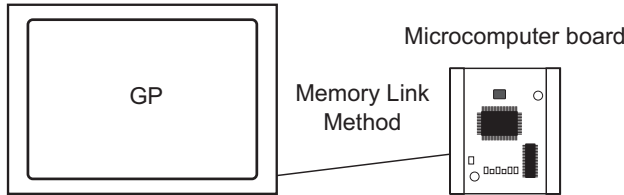

The Memory Link Method is used to connect with devices, or hosts, that do not contain a communication protocol, such as a computer or a microprocessor board.

■ Memory Link Method

In the Memory Link Method, a data read/write request occurs from the host to the GP, as in the following image. The GP displays data that was sent in response to the host's write request. In response to a read request, the GP sends stored data to the host.

- NOTE**
- Communication based on the Memory Link Method is accomplished by executing a program on the host.

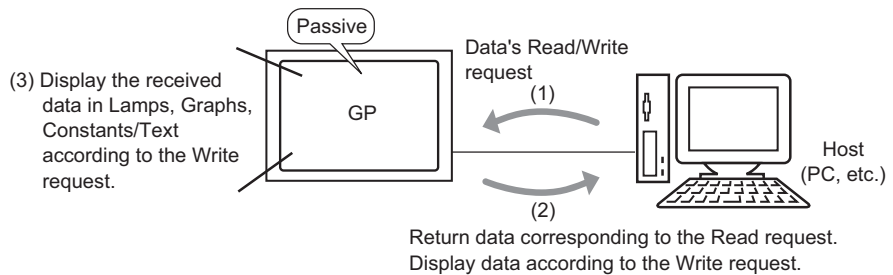

◆ Usable Addresses

For the GP to get the necessary display data from the host, set an address that can reference data and set the Parts or script features. There are two types of address inside the GP that can be set as a reference destination.

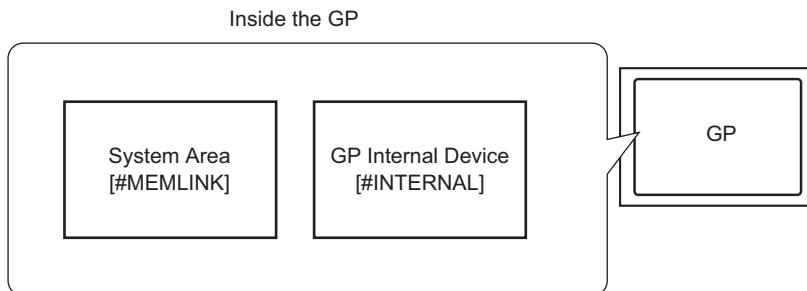

- **Memory Link System Area Addresses**
The System Area is used to request the host's read/write. It is the Memory Link Method's communication area.

For details regarding the System Area, please refer to "A.1.5 System Area (Memory Link Area)" (page A-29).

For example, to set a Word Switch address settings, select [#MEMLINK] from [Device/PLC] and enter the address (for example, "0100").

For example, an Input Address screen on a Word Switch.

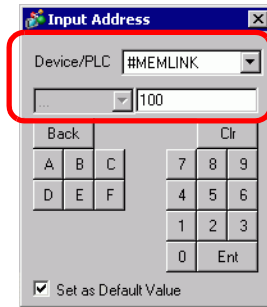

- GP Internal Device Address

For example, you can use the internal device as a temporary storage area when you need to refer to calculated values. You cannot use the internal device with Memory Link communication.

For the [Device/PLC] select [#INTERNAL], which refers to the GP internal device, and enter that address (for example, "USR00100").

For example, an Input Address screen on a Word Switch.



NOTE

- When using Memory Link communication with the GP internal device [#INTERNAL], you can only use the [USR] area. When using Direct Access communication or other device/PLC drivers, you can also use the [#INTERNAL] [LS] area.
-

A.1.4 LS Area (Direct Access Method)

When communicating inside the GP using the Direct Access Method, the LS area is secured. This area is useful for temporarily storing control handling within a GP that does not have a device/PLC address (for example, a switch's Interlock Settings), or for temporarily storing values calculated within the GP.

A.1.4.1 LS Area List

Direct Access Method's LS Area

LS0000	System Data Area
LS0020	Read Area
(LS0276 *1)	User Area
LS2032	Special Relay Area
LS2048	Reserved
LS2096	User Area
LS9000	LS9000 Area
LS9999	

IMPORTANT

- Do not set addresses for Parts which span the System Data Area and Read Area, or the Read Area and User Area.
- When setting addresses for Parts in the System Data Area, set the data length as 16 bit.

*1 The System Data Area can exclusively use a maximum of 20 words. The Read Area can exclusively use a maximum of 256 words. The User Area's top address is the Read Area's top address (20) + Read Area's size.

Area Name	Description
System Data Area	<p>This area stores data required for system operations, such as the GP screen control data and error information.</p> <p>☞ "A.1.4.2 System Data Area" (page A-10)</p> <p>When referencing a screen number that displays on the GP from a device/PLC or changing screens, you can establish an area in the device/PLC to link with this area to reference and control the GP data.</p> <p>☞ "A.1.4.4 Device/PLC System Data Area Allocation Procedure" (page A-26)</p>
Read Area	<p>This area stores data used commonly by all screens.</p> <p>The area size is variable and can be set up to 256 words.</p> <p>When referencing a screen number that displays on the GP from a device/PLC or changing screens, you can establish an area in the device/PLC to link with this area to reference and control the GP data.</p> <p>☞ "A.1.4.4 Device/PLC System Data Area Allocation Procedure" (page A-26)</p>

Continued

Area Name	Description
User Area	This device can only be allocated inside the GP; not to the device/PLC. Use it for addresses that can only be processed with the GP. You cannot control it from the device/PLC.
Special Relay Area	This area stores each type of status information that occurs when the GP communicates. ☞ "A.1.4.3 Special Relay" (page A-23)
Reserved	Used inside the GP. Do not use this area. It will not operate normally.
LS9000 Area	Stores the GP's internal operating information such as a Trend Graph's historical data and the communication scan time. There is also an adjustable portion. ☞ "7.3.2 Setup Procedure ■ Stop Communications" (page 7-13)

NOTE

- The following describes how to specify the LS Area.

◆ Specifying Word Addresses

For example, "LS0000"

_____ Set from 0000 to 9999

◆ Specifying Bit Addresses

For example, "LS0000 00"

_____ Designate from 00 to 15 (Bit Number)

_____ Designate from 0000 to 9999

A.1.4.2 System Data Area

This shows the contents of write data in each address of the System Data Area.

■ One Address Communicating with a 16 bit Device/PLC

NOTE

- The following table's "Word Address" column shows the Word addresses added from the System Data Area's top address in the device/PLC. (When all items are selected from the GP's LS0000 to LS0019)
- LS0000 to 0007 is the GP PLC write-only area, and LS0008 to 0019 is read-only area.

GP Internal Address	Word Address	Description	Bit	Details	H System Variable
LS0000	+0	Current Screen Number	-	1 to 9999 (BIN) 1 to 7999 (BCD)	#H_CurrentScreenNo
LS0001	+1	Error Status	0 to 2	Unused	-
			3	Screen Memory Checksum	
			4	SIO Framing	
			5	SIO Parity	
			6	SIO Overrun	
			7 to 9	Unused	
			10	Backup Battery Low Voltage	
			11	PLC Communication Error	
12 to 15	Unused				
LS0002	+2	Clock's current "Year" value	-	Last 2 digits of year (2 BCD digits)	#H_CurrentYear
LS0003	+3	Clock's current "Month" value	-	01 to 12 (2 BCD digits)	#H_CurrentMonth
LS0004	+4	Clock's current "Day" value	-	01 to 31 (2 BCD digits)	#H_CurrentDay
LS0005	+5	Clock's current "Time" value	-	Hours: 00 to 23; Minutes: 00 to 59 (4 BCD digits)	Hours: #H_CurrentHour Minutes: #H_CurrentMinute

Continued

GP Internal Address	Word Address	Description	Bit	Details	H System Variable
LS0006	+6	Status	0 to 1	Reserved	-
			2	Printing	#H_Status_Print
			3	Data Display Part Write Setting Value	-
			4 to 7	Reserved	-
			8	Data Display Part Input Error	-
			9	Display ON/OFF ON, 1: OFF	#H_Status_DispOnOff
			10	Detect Backlight Burnout	-
			11 to 15	Reserved	-
LS0007	+7	Reserved	-	Reserved	-
LS0008	+8	Change-To Screen	-	1 to 9999 (BIN) 1 to 7999 (BCD)*1	#H_ChangeScreenNo
LS0009	+9	Screen Display ON/OFF	-	Turn Screen Display OFF with FFFFh Display screen with 0h	-
LS0010	+10	Clock's "Year" setting value	-	Last 2 digits of year (2 BCD digits) (Bit 15 is the clock data's rewrite flag)	#H_SetYear
LS0011	+11	Clock's "Month" setting value	-	01 to 12 (2 BCD digits)	#H_SetMonth
LS0012	+12	Clock's "Day" setting	-	01 to 31 (2 BCD digits)	#H_SetDay
LS0013	+13	Clock's "Time" setting	-	Hours: 00 to 23; Minutes: 00 to 59 (4 BCD digits)	#H_SetHour #H_SetMinute

Continued

GP Internal Address	Word Address	Description	Bit	Details	H System Variable
LS0014	+14	Control	0	Backlight OFF	-
			1	Buzzer ON	#H_Control_Buzzer
			2	Print Started	#H_Control_HardcopyPrint
			3	Reserved	-
			4	Buzzer	#H_Control_BuzzerEnable
			5	AUX Output	-
			6 to 10	Reserved	-
			11	Print Canceled	#H_Control_PrintCancel
			12 to 15	Reserved	-
LS0015	+15	Reserved	-	Reserved	-
LS0016	+16	Window Screen Control	0	Window Display 0: OFF, 1: ON	#H_GlobalWindowControl
			1	Window overlap order Change 0: Permitted, 1: Not permitted	
			2 to 15	Reserved	
LS0017	+17	Window Number	-	Global Window's registration number selected indirectly: 1 to 2000 (BIN/BCD).	#H_GlobalWindowNo
LS0018	+18	Window Display Position (X Coordinate)	-	Indirectly specified Global Window's top-left display position (Bin/BCD)	#H_GlobalWindowPosX
LS0019	+19	Window Display Position (Y Coordinate)	-		#H_GlobalWindowPosY

IMPORTANT

- Normally, when turning OFF the Screen Display, do not use +14 (Control)'s "Backlight OFF" bit. Use +9 [Screen Display ON/OFF].

- *1 When you do not specify [Reflect in Device/PLC] from the [System Settings] window, [Display Unit] link's [Display] tab, you cannot return to the screen number from which you switched by touch from the device/PLC. To force the screen to switch, turn ON bit 15 of the address, specify the screen number to which you want to switch from bits 0 -14. (Input the 8000h + the value of screen number to which you want to switch in the address.)

For example, to enable forced screen switching:

8000(h)+1999(h)=9999(h) write "9999" to the address.

Caution)

While forced screen switching is enabled (Bit 15 is ON), screen switching by touch is not enabled.

When the data format is BCD, you cannot change to screens numbered 2000 or higher.

■ One Address Communicating with an 8-bit Device/PLC

NOTE

- The following table's "Word Address" column shows the Word addresses added from the System Data Area's top address in the device/PLC. (When all items are selected from the GP's LS0000 to LS0019)
- LS0000 to 0007 is the GP PLC write-only area, and LS0008 to 0019 is read-only area.
- The PLC determines the byte order (Low or High) and how data displays

GP Internal Address	Byte		Description	Order	Bit	Details	H System Variable
	Decimal	Octal					
LS0000	+0	+0	Current Screen Number		-	1 to 9999 (BIN) 1 to 7999 (BCD)	#H_CurrentScreenNo
	+1	+1					
LS0001	+2	+2	Error Status	Low	0 to 2	Unused	-
					3	Screen Memory Checksum	
					4	SIO Framing	
					5	SIO Parity	
					6	SIO Overrun	
	7	Unused					
	+3	+3		High	0 to 1	Unused	
					2	Backup Battery Low Voltage	
					3	PLC Communication Error	
					4 to 7	Unused	
LS0002	+4	+4	Clock's current "Year" value		-	2 Digit Year (BCD 2 digits)	#H_CurrentYear
	+5	+5					
LS0003	+6	+6	Clock's current "Month" value		-	01 to 12 (2 BCD digits)	#H_CurrentMonth
	+7	+7					
LS0004	+8	+10	Clock's current "Day" value		-	01 to 31 (2 BCD digits)	#H_CurrentDay
	+9	+11					
LS0005	+10	+12	Clock's current "Time" value		-	Hours: 00 to 23, Minutes: 00 to 59 (4 BCD digits)	Hours: #H_CurrentHour Minutes: #H_CurrentMinute
	+11	+13					

Continued

GP Internal Address	Byte		Description	Order	Bit	Details	H System Variable
	Decimal	Octal					
LS0006	+12	+14	Status	Low	0 to 1	Reserved	-
					2	Printing	#H_Status_Print
					3	Data Display Part Write Value	-
					4 to 7	Reserved	-
	+13	+15		High	0	Data Display Part Input Error	-
					1	Display ON/OFF 0: ON; 1:OFF	#H_Status_DispOnOff
					2	Detect Backlight Burnout	-
					3 to 7	Reserved	-
LS0007	+14	+16	Reserved		-	Reserved	-
	+15	+17					
LS0008	+16	+20	Change-To Screen		-	1 to 9999 (BIN) 1 to 7999 (BCD)*1	#H_ChangeScreenNo
	+17	+21					
LS0009	+18	+22	Screen Display ON/OFF		-	Turn Screen Display OFF with FFFFh Turn Screen Display ON with 0h	-
	+19	+23					
LS0010	+20	+24	Clock's "Year" setting value		-	2 Digit Year (BCD 2 digits) (Bit 15 is the clock data's rewrite flag)	#H_SetYear
	+21	+25					
LS0011	+22	+26	Clock's "Month" setting value		-	01 to 12 (2 BCD digits)	#H_SetMonth
	+23	+27					
LS0012	+24	+30	Clock's "Day" setting		-	01 to 31 (2 BCD digits)	#H_SetDay
	+25	+31					
LS0013	+26	+32	Clock's "Time" setting		-	Hours: 00 to 23; Minutes: 00 to 59 (4 BCD digits)	#H_SetHour #H_SetMinute
	+27	+33					

Continued

GP Internal Address	Byte		Description	Order	Bit	Details	H System Variable
	Decimal	Octal					
LS0014	+28	+34	Control	Low	0	Backlight OFF	-
					1	Buzzer ON	#H_Control_Buzzer
					2	Print Started	#H_Control_Hardcopy Print
					3	Reserved	-
					4	Buzzer	#H_Control_Buzzer Enable
					5	AUX Output	-
	6 to 7	Reserved		-			
	+29	+35		High	0 to 2	Reserved	-
					3	Print Canceled	#H_Control_PrintCancel
4 to 7			Reserved		-		
LS0015	+30	+36	Reserved		-	Reserved	-
	+31	+37					
LS0016	+32	+40	Window Control	Low	0	Window Display 0: OFF; 1: ON	#H_GlobalWindow Control
					1	Change Window overlap order 0: Enable; 1: Disable	
					2 to 7	Reserved	
	+33	+41		High	0 to 7	Reserved	
LS0017	+34	+42	Window Number		-	Global Window's registration number selected indirectly: 1 to 2000 (BIN/BCD)	#H_GlobalWindowNo
	+35	+43					
LS0018	+36	+44	Window Display Position (X Coordinate)		-	Indirectly specified Global Window's top- left display coordinate (Bin/ BCD)	#H_GlobalWindowPosX
	+37	+45					
LS0019	+38	+46	Window Display Position (Y Coordinate)		-		#H_GlobalWindowPosY
	+39	+47					

- *1 When you do not specify [Reflect in Device/PLC] from the [System Settings] [Display Unit] [Display] tab, you cannot return to the screen number from which you switched by touch from the device/PLC. To force the screen to switch, turn ON bit 15 of the address, specify the screen number to which you want to switch from bits 0 -14. (Input the 8000h + the value of screen number to which you want to switch in the address.)

For example, to enable forced screen switching:

8000(h)+1999(h)=9999(h) write "9999" to the address.

Caution:

While forced screen switching is enabled (Bit 15 is ON), screen switching by touch is not enabled.

When the data format is BCD, you cannot change to screens numbered 2000 or higher.

IMPORTANT

- Normally, when turning the Screen Display OFF, do not use the Backlight OFF control bit (Byte Address +28 in decimal format or Byte Address +34 in the octal format.) Instead, use the Screen Display ON/OFF address (Byte Address +18 in decimal format or Byte Address +22 in octal format.)
-

■ Details About Each Address

Description	Details																																												
Current Screen Number	Stores the screen number that currently displays on the GP.																																												
Error Status	<p>When an error occurs in the GP, the corresponding bit turns ON. After the bit turns ON and the power turns OFF, the status is maintained until the GP changes from offline mode back to active mode.</p> <table border="1"> <thead> <tr> <th>Bit 16 Bits)</th> <th>Bit (8 Bits)</th> <th>Description</th> <th>Details</th> </tr> </thead> <tbody> <tr> <td>0 to 2</td> <td>0 to 2</td> <td>Unused</td> <td></td> </tr> <tr> <td>3</td> <td>3</td> <td>Screen Memory Checksum</td> <td>There is an error in the project file. Transfer it again.</td> </tr> <tr> <td>4</td> <td>4</td> <td>SIO Framing</td> <td></td> </tr> <tr> <td>5</td> <td>5</td> <td>SIO Parity</td> <td></td> </tr> <tr> <td>6</td> <td>6</td> <td>SIO Overrun</td> <td></td> </tr> <tr> <td>7</td> <td>7</td> <td>Unused</td> <td></td> </tr> <tr> <td>8 to 9</td> <td>0 to 1</td> <td>Unused</td> <td></td> </tr> <tr> <td>10</td> <td>2</td> <td>Backup Battery Low Voltage</td> <td>This turns ON when the voltage of the backup lithium battery is low. The backup battery is used by the clock and SRAM.</td> </tr> <tr> <td>11</td> <td>3</td> <td>PLC Communication Error</td> <td>Error in communication with device/PLC, caused by bits 4 to 6, or other cause.</td> </tr> <tr> <td>12 to 15</td> <td>4 to 7</td> <td>Unused</td> <td></td> </tr> </tbody> </table>	Bit 16 Bits)	Bit (8 Bits)	Description	Details	0 to 2	0 to 2	Unused		3	3	Screen Memory Checksum	There is an error in the project file. Transfer it again.	4	4	SIO Framing		5	5	SIO Parity		6	6	SIO Overrun		7	7	Unused		8 to 9	0 to 1	Unused		10	2	Backup Battery Low Voltage	This turns ON when the voltage of the backup lithium battery is low. The backup battery is used by the clock and SRAM.	11	3	PLC Communication Error	Error in communication with device/PLC, caused by bits 4 to 6, or other cause.	12 to 15	4 to 7	Unused	
Bit 16 Bits)	Bit (8 Bits)	Description	Details																																										
0 to 2	0 to 2	Unused																																											
3	3	Screen Memory Checksum	There is an error in the project file. Transfer it again.																																										
4	4	SIO Framing																																											
5	5	SIO Parity																																											
6	6	SIO Overrun																																											
7	7	Unused																																											
8 to 9	0 to 1	Unused																																											
10	2	Backup Battery Low Voltage	This turns ON when the voltage of the backup lithium battery is low. The backup battery is used by the clock and SRAM.																																										
11	3	PLC Communication Error	Error in communication with device/PLC, caused by bits 4 to 6, or other cause.																																										
12 to 15	4 to 7	Unused																																											
Clock Data (Current)	<p>Stored as BCD. [Year] is the 2 digits of the year, [Month] is 2 digits from 01 to 12, [Day] is 2 digits from 01 to 31, [Time] is 2 digits for the hours from 00 to 23, and 2 digits for the minutes from 00 to 59 for a total of 4 digits.</p> <p>NOTE</p> <ul style="list-style-type: none"> The current value for the day is stored in LS9310. The day is calculated from the Year, Month, and Day of the GP's onboard IC (RTC) clock. <p>The value is stored in LS9310 as follows.</p> <table border="1"> <thead> <tr> <th>Value</th> <th>Description</th> </tr> </thead> <tbody> <tr> <td>0</td> <td>Sunday</td> </tr> <tr> <td>1</td> <td>Monday</td> </tr> <tr> <td>2</td> <td>Tuesday</td> </tr> <tr> <td>3</td> <td>Wednesday</td> </tr> <tr> <td>4</td> <td>Thursday</td> </tr> <tr> <td>5</td> <td>Friday</td> </tr> <tr> <td>6</td> <td>Saturday</td> </tr> <tr> <td>After 7</td> <td>Unused</td> </tr> </tbody> </table> <p>Updates are performed when the IC clock date is changed. Because the writes do not occur regularly, when parts change in this area, this area is not updated until the IC clock date changes.</p>	Value	Description	0	Sunday	1	Monday	2	Tuesday	3	Wednesday	4	Thursday	5	Friday	6	Saturday	After 7	Unused																										
Value	Description																																												
0	Sunday																																												
1	Monday																																												
2	Tuesday																																												
3	Wednesday																																												
4	Thursday																																												
5	Friday																																												
6	Saturday																																												
After 7	Unused																																												

Continued

Description	Details			
Status	Monitor only the necessary bits. Do not turn reserved bits ON/OFF because they are sometimes used for GP system maintenance.			
	Bit 16 Bits)	Bit (8 Bits)	Description	Details
	0, 1	0, 1	Reserved	-
	2	2	Printing	Turns ON during printing. While this bit is ON, there are cases when the offline screen appears or when output is disturbed.
	3	3	Write Setting Value	This bit is reversed each time a write occurs from a Data Display (Setting Value Input).
	4 to 7	4 to 7	Reserved	-
	8	0	Data Display Part Input Error	When Alarms are set for the Data Display where you enter a value outside of the alarm range, this bit turns ON. When you input a value inside the alarm range or change screens, this bit turns OFF.
	9	1	Display ON/OFF (0: ON, 1: OFF)	This can detect whether to turn the GP's screen display ON/OFF from the device/PLC. This bit changes in the following cases. (1) When FFFFh is written to the System Data Area's Display ON/OFF, the display turns OFF. (2) When the standby time passes, the display turns OFF (3) If the screen changes or is touched after the display turns OFF, the display turns back ON. NOTE • This bit cannot change LS0014 "Control"'s 0 bit (Backlight OFF).
	10	2	Detect Backlight Burnout	When an expired backlight is detected, this bit turns ON.
11 to 15	3 to 7	Reserved	-	

Continued

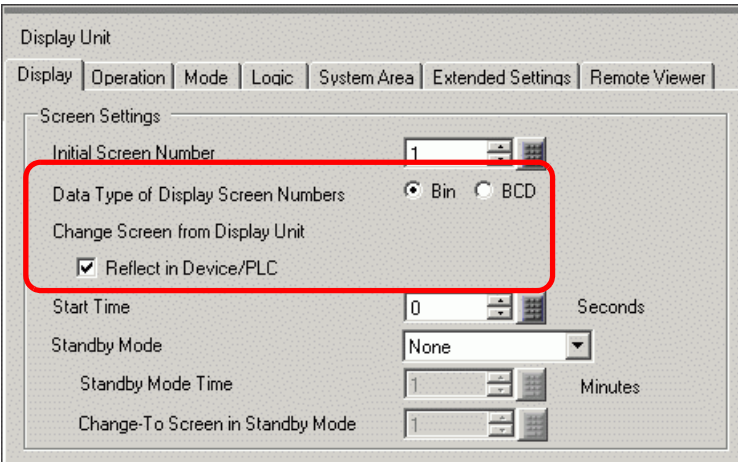
Description	Details																		
<p>Change-To Screen</p>	<p>Set the Change-to Screen Number. The setting range differs depending on whether or not [Data Type of Display Screen Numbers] and [Change Screen from Display Unit - Reflect in Device/PLC] are set on the [System Settings] window, [Display Unit] link's [Display] tab.</p>  <p>When [Data Type of Display Screen Numbers] is [Bin]:</p> <table border="1" data-bbox="400 846 1173 981"> <thead> <tr> <th>Reflect in Device/PLC</th> <th>Screen Change from Device/PLC</th> <th>Screen Change from Display Unit</th> </tr> </thead> <tbody> <tr> <td>Enable</td> <td>1 to 9999</td> <td>1 to 9999</td> </tr> <tr> <td>Disable</td> <td>1 to 9999</td> <td>1 to 9999</td> </tr> </tbody> </table> <p>When [Data Type of Display Screen Numbers] is [BCD]:</p> <table border="1" data-bbox="400 1047 1173 1182"> <thead> <tr> <th>Reflect in Device/PLC</th> <th>Screen Change from Device/PLC</th> <th>Screen Change from Display Unit</th> </tr> </thead> <tbody> <tr> <td>Enable</td> <td>1 to 7999</td> <td>1 to 7999</td> </tr> <tr> <td>Disable</td> <td>1 to 1999</td> <td>1 to 7999</td> </tr> </tbody> </table>	Reflect in Device/PLC	Screen Change from Device/PLC	Screen Change from Display Unit	Enable	1 to 9999	1 to 9999	Disable	1 to 9999	1 to 9999	Reflect in Device/PLC	Screen Change from Device/PLC	Screen Change from Display Unit	Enable	1 to 7999	1 to 7999	Disable	1 to 1999	1 to 7999
Reflect in Device/PLC	Screen Change from Device/PLC	Screen Change from Display Unit																	
Enable	1 to 9999	1 to 9999																	
Disable	1 to 9999	1 to 9999																	
Reflect in Device/PLC	Screen Change from Device/PLC	Screen Change from Display Unit																	
Enable	1 to 7999	1 to 7999																	
Disable	1 to 1999	1 to 7999																	
<p>Screen Display ON/OFF</p>	<p>Shows the screen when the value is "0h" and hides the screen when the value is "FFFFh". Values other than "0h" and "FFFFh" are reserved. When the screen display is hidden, the next touch on the screen will turn the display back ON.</p>																		
<p>Clock Data (Current Value)</p>	<p>Set as BCD. [Year] is the 2 digits of the year, [Month] is 2 digits from 01 to 12, [Day] is 2 digits from 01 to 31, [Time] is 2 digits for the hours from 00 to 23, and 2 digits for the minutes from 00 to 59 for a total of 4 digits.</p> <p>■For example,< October 19, 2005, 21:57></p> <p>(1) When the current Word Address "+10" data is "0000",</p> <ul style="list-style-type: none"> - "Month" - Write "0010" Word Address "+11" - "Day" - Write "0019" Word Address "+12" - "Time" - Write "2157" Word Address "+13" <p>(2) When you write "8005" to Word Address "+10," bit 15 of "+10" turns ON, and clock data is rewritten. For "8005," bit 15 is turned ON by the "8000" portion, while the "Year" is set with "05".</p>																		

Continued

Description	Details		
Control	<p>NOTE</p> <ul style="list-style-type: none"> • Please make sure to write this address in bit units. In some cases, writing with word data can change the value. • "Reserved" bits are sometimes used for maintenance of the GP's system. Turn them OFF. 		
	Bit 16 Bits)	Bit (8 Bits)	Description Details
	0	0	Backlight OFF When ON, the backlight turns OFF. When OFF, the backlight turns ON. (The parts placed on the screen function while the LCD is lit.) <p>NOTE</p> <ul style="list-style-type: none"> • Normally, when turning OFF the screen display, use Word Address "+9" (Screen Display ON/OFF).
	1	1	Buzzer ON 0:Do not sound, 1: Sound
	2	2	Print Started 0:Do not sound, 1: Sound When the bit turns ON, the printing screen data starts. <p>NOTE</p> <ul style="list-style-type: none"> • When Status "Bit 2" (Printing) turns ON, turn it OFF manually.
	3	3	Reserved 0 Fixed
	4	4	Buzzer The following action occurs only when Control "Bit 1" (Buzzer ON) is ON. 0:Sound, 1: Do not sound To stop the buzzer sound, turn this bit ON.
	5	5	AUX Output The following action occurs only when Control "Bit 1" (Buzzer ON) is ON. 0:Sound, 1: Do not sound To stop the AUX output, turn this bit ON.
	6 to 7	6 to 7	Reserved 0 Fixed
	8 to 10	0 to 2	Reserved 0 Fixed
11	3	Print Canceled 0:Sound, 1: Do not sound When the bit turns ON, all current printing is canceled. <p>NOTE</p> <ul style="list-style-type: none"> • After printing stops and Status "Bit 2" (Printing) turns OFF, turn it OFF manually. • Even when the Print Canceled bit turns ON, data previously sent to the printer is printed. 	
12 to 15	4 to 7	Reserved 0 Fixed	

Continued

Description	Details
Window Number	Stores the Global Window's registration number selected indirectly: 1 to 2000 (BIN/BCD).
Window Display Position	Stores the Global Window's top-left display position, selected indirectly. "+18" shows the X coordinate, "+19" shows the Y coordinate. The data type is BIN or BCD.



A.1.4.3 Special Relay

- ⊘ The Special Relay is not write-protected. Do not turn it ON/OFF with Parts or write Words.

The Special Relay has the following structure.

Direct Access Method

Address	Description	H System Variable
LS2032	Common Relay Information	
LS2033	Base Screen Information	
LS2034	Reserved	
LS2035	1-Second Binary Counter	
LS2036	Display Scan Time	#H_DispScanTime
LS2037	Communication Cycle Time	
LS2038	Display scan counter	#H_DispScanCounter
LS2039	Communication Error Code	
LS2040	Reserved	
LS2041		
LS2042		
LS2043		
LS2044		
LS2045		
LS2046		
LS2047		

Description	Details																																		
<p>Common Relay Information (LS2032)</p>	<div style="text-align: center; margin-bottom: 10px;"> <p>15 14 13 12 11 10 9 8 7 6 5 4 3 2 1 0 Bit</p>  </div> <table border="1" style="width: 100%; border-collapse: collapse;"> <thead> <tr> <th style="width: 10%;">Bit</th> <th>Description</th> </tr> </thead> <tbody> <tr> <td>0</td> <td>Toggles ON/OFF every communication cycle.</td> </tr> <tr> <td>1</td> <td>After a Base screen or Window changes, turns ON until communication with all the device addresses set in the screen has succeeded and the Part operation or process has completed.</td> </tr> <tr> <td>2</td> <td>Turns ON only when a communication error occurs.</td> </tr> <tr> <td>3</td> <td>Turns ON while the initial screen displays at power ON.</td> </tr> <tr> <td>4</td> <td>Normally ON.</td> </tr> <tr> <td>5</td> <td>Normally OFF.</td> </tr> <tr> <td>6</td> <td>Turns ON when backup SRAM data is erased. (Only onboard backup SRAM)</td> </tr> <tr> <td>7</td> <td>When using D-Scripts, turns ON when a BCD error occurs.</td> </tr> <tr> <td>8</td> <td>When using D-Scripts, turns ON when a zero error occurs.</td> </tr> <tr> <td>9</td> <td>Turns ON when a recipe could not be transferred to backup SRAM.</td> </tr> <tr> <td>10</td> <td>Turns ON when a recipe transferred according to the Control Word Address could not be transferred from PLC SRAM. Also, if transferring between the PLC by means of a Special Data Display (filing), when there is a Transfer Complete Bit Address, turns ON when data could not be transferred from PLC Area, or PLC SRAM.</td> </tr> <tr> <td>11</td> <td>Turns ON while transferring filing data between SRAM LS Area by means of a Special Data Display (Filing).</td> </tr> <tr> <td>12</td> <td>When using D-Scripts, turns ON when a communication error occurs from a memcopy () or address offset designation read. Turns OFF when data finishes reading normally.</td> </tr> <tr> <td>13</td> <td>In the [System Settings] [Script I/O] page, when no [D-Script/Global D-Script] is set in the project, turns ON when the readout of the Send function, Receive function, Control, Status variable, and Received Data Size is executed in [SIO Port Operation]'s Label Settings.</td> </tr> <tr> <td>14</td> <td>In the [System Settings] [Script I/O] page, when [D-Script/Global D-Script] is set in the project, turns ON when an extended script's [Text Operation] function is executed. Also, in the [System Settings] [Script I/O] page, when [Extended Script] is set in the project, turns ON even when a D-Script/Global D-Script [SIO Port Operation]'s I/O function (IO_WRITE, IO_READ) is executed.</td> </tr> <tr> <td>15</td> <td>Reserved</td> </tr> </tbody> </table>	Bit	Description	0	Toggles ON/OFF every communication cycle.	1	After a Base screen or Window changes, turns ON until communication with all the device addresses set in the screen has succeeded and the Part operation or process has completed.	2	Turns ON only when a communication error occurs.	3	Turns ON while the initial screen displays at power ON.	4	Normally ON.	5	Normally OFF.	6	Turns ON when backup SRAM data is erased. (Only onboard backup SRAM)	7	When using D-Scripts, turns ON when a BCD error occurs.	8	When using D-Scripts, turns ON when a zero error occurs.	9	Turns ON when a recipe could not be transferred to backup SRAM.	10	Turns ON when a recipe transferred according to the Control Word Address could not be transferred from PLC SRAM. Also, if transferring between the PLC by means of a Special Data Display (filing), when there is a Transfer Complete Bit Address, turns ON when data could not be transferred from PLC Area, or PLC SRAM.	11	Turns ON while transferring filing data between SRAM LS Area by means of a Special Data Display (Filing).	12	When using D-Scripts, turns ON when a communication error occurs from a memcopy () or address offset designation read. Turns OFF when data finishes reading normally.	13	In the [System Settings] [Script I/O] page, when no [D-Script/Global D-Script] is set in the project, turns ON when the readout of the Send function, Receive function, Control, Status variable, and Received Data Size is executed in [SIO Port Operation]'s Label Settings.	14	In the [System Settings] [Script I/O] page, when [D-Script/Global D-Script] is set in the project, turns ON when an extended script's [Text Operation] function is executed. Also, in the [System Settings] [Script I/O] page, when [Extended Script] is set in the project, turns ON even when a D-Script/Global D-Script [SIO Port Operation]'s I/O function (IO_WRITE, IO_READ) is executed.	15	Reserved
Bit	Description																																		
0	Toggles ON/OFF every communication cycle.																																		
1	After a Base screen or Window changes, turns ON until communication with all the device addresses set in the screen has succeeded and the Part operation or process has completed.																																		
2	Turns ON only when a communication error occurs.																																		
3	Turns ON while the initial screen displays at power ON.																																		
4	Normally ON.																																		
5	Normally OFF.																																		
6	Turns ON when backup SRAM data is erased. (Only onboard backup SRAM)																																		
7	When using D-Scripts, turns ON when a BCD error occurs.																																		
8	When using D-Scripts, turns ON when a zero error occurs.																																		
9	Turns ON when a recipe could not be transferred to backup SRAM.																																		
10	Turns ON when a recipe transferred according to the Control Word Address could not be transferred from PLC SRAM. Also, if transferring between the PLC by means of a Special Data Display (filing), when there is a Transfer Complete Bit Address, turns ON when data could not be transferred from PLC Area, or PLC SRAM.																																		
11	Turns ON while transferring filing data between SRAM LS Area by means of a Special Data Display (Filing).																																		
12	When using D-Scripts, turns ON when a communication error occurs from a memcopy () or address offset designation read. Turns OFF when data finishes reading normally.																																		
13	In the [System Settings] [Script I/O] page, when no [D-Script/Global D-Script] is set in the project, turns ON when the readout of the Send function, Receive function, Control, Status variable, and Received Data Size is executed in [SIO Port Operation]'s Label Settings.																																		
14	In the [System Settings] [Script I/O] page, when [D-Script/Global D-Script] is set in the project, turns ON when an extended script's [Text Operation] function is executed. Also, in the [System Settings] [Script I/O] page, when [Extended Script] is set in the project, turns ON even when a D-Script/Global D-Script [SIO Port Operation]'s I/O function (IO_WRITE, IO_READ) is executed.																																		
15	Reserved																																		
<p>Base Screen Information (LS2033)</p>	<div style="text-align: center; margin-bottom: 10px;"> <p>15 1 0 Bit</p>  </div> <p style="text-align: center;">This bit stays ON from the time the base screen changes until handling of all parts is complete.</p> <p style="text-align: right; margin-right: 100px;">Reserved</p>																																		

Continued

Description	Details
Reserved (LS2034, LS2040 to LS2047)	Values are undefined in reserved addresses. Do not use.
1-Second Binary Counter (LS2035)	Increments once every second immediately after the power is turned ON. The data is binary.
Display Scan Time (LS2036)	<p>The display time starts from the first Part set on the display screen to the end of the last Part. Data is stored in binary format, with units in milliseconds. The data is updated when all processing for the target Parts has finished. The data's initial value is "0".</p> <p>There is an error of ± 10 milliseconds.</p>
Communication Cycle Time (LS2037)	<p>One cycle's time is from the start to the end of the management of the System Data Area allotted inside the device/PLC, and each type of device. Data is stored in binary format, in units of 10 milliseconds. The data is updated when all processing for the System Data Area and target device has finished. The data's initial value is "0". There is an error of ± 10 milliseconds.</p> <p>NOTE</p> <ul style="list-style-type: none"> When multiple devices/PLCs are connected to a single GP, the System Data Area can only be allotted to one device/PLC.
Display Scan Counter (LS2038)	The counter increments each time the Part set on the display screen processes. The data is binary.
Communication Error Code (LS2039)	When a communication error occurs, this stores the last displayed communication error code in binary.

A.1.1.4.4 Device/PLC System Data Area Allocation Procedure

When referencing a screen number that displays on the GP from a device/PLC or changing screens, to reference/control the GP's data, share the GP's internal System Data Area's allocated data with the device/PLC.

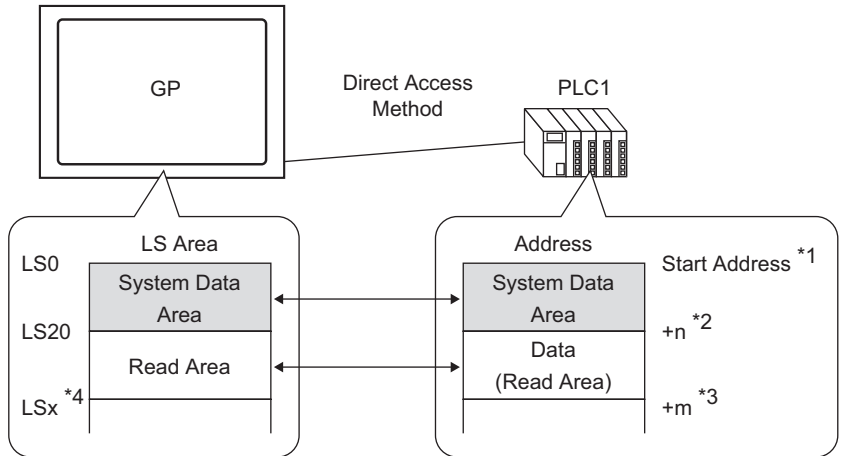

- *1 Set up the start address with the process on the next page.
- *2 $n = 0$ to 20. This depends on the number of selected items in the GP's set System Data Area.
- *3 This is the Read Area Size.
- *4 $*$ = Read Area Start Address (20) + Read Area Size (m)

IMPORTANT

- When multiple devices/PLCs are connected to a single GP, the System Data Area can only be allotted to one device/PLC.
- Do not set addresses for Parts which span the System Data Area and Read Area, or the Read Area and User Area.
- When setting addresses for Parts in the System Data Area, set the data length as 16 bit.

NOTE

- The number of addresses that can be set in the System Data Area differs depending on the device/PLC. For details, please refer to the GP-Pro EX Device/PLC Connection Manual.

- 1 From the [Project (F)] menu, select [System Settings (C)] or click . In [System Settings], select [Display Unit]. In [Display Unit], select the [System Area] tab. The following dialog box appears.

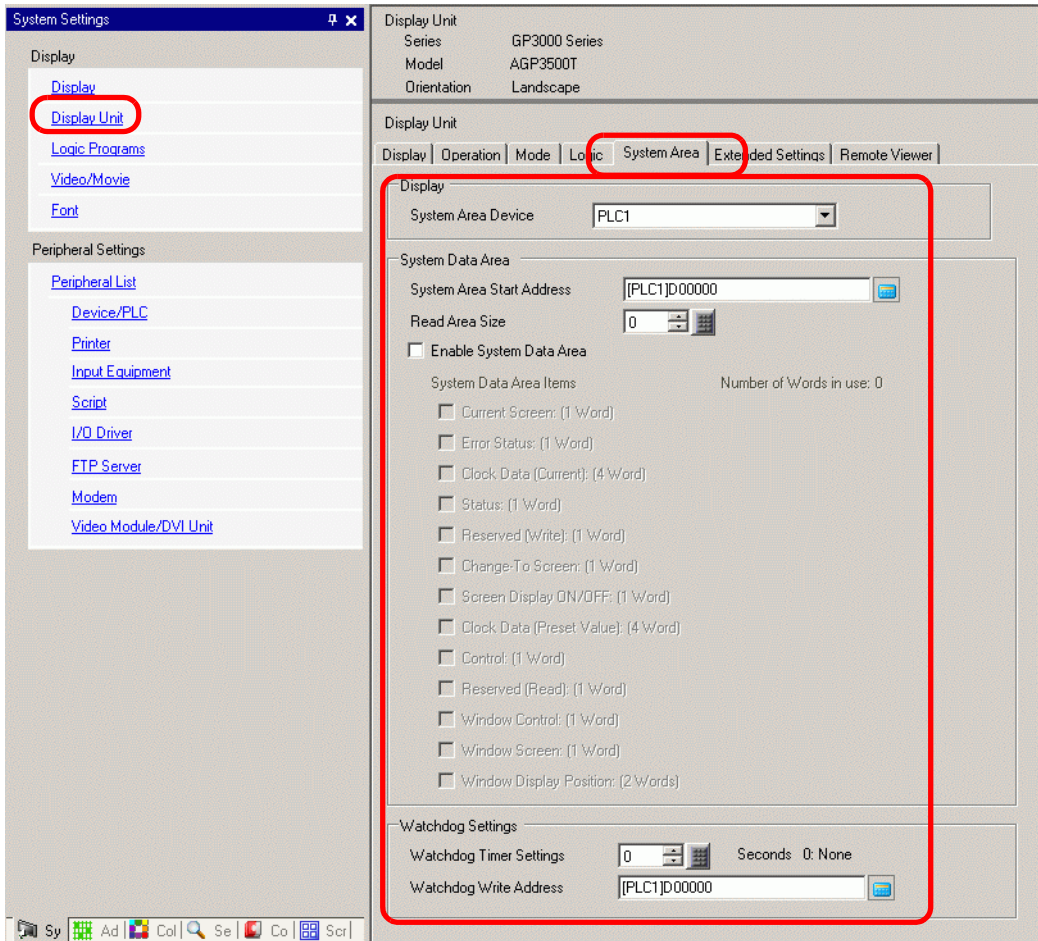

- 2 Assign the addresses in the device/PLC you will communicate with. In [System Area Device], select the device/PLC where you will assign addresses and set the start address of an area that has 16 words or more of continuous addresses in [System Area Start Address]. (For example, [PLC1] D00000)

NOTE

- Data used in all common screens and Line Charts' block display data is stored in the "Read Area." According to the needed capacity, set a [Read Area Size] of up to 256 words. Use the LS area exclusively as the read area starting from the address on the right (example: [PLC1]D00000) and continuing for the designated number of words.

3 Select the [Enable System Data Area] check box. Sixteen words are allocated from the start address.

☞ "A.1.5.2 System Data Area" (page A-30)

<input checked="" type="checkbox"/> Enable System Data Area	
System Data Area Items	Number of Words in use: 16
<input checked="" type="checkbox"/> Current Screen: (1 Word)	[PLC1]D00000
<input checked="" type="checkbox"/> Error Status: (1 Word)	[PLC1]D00001
<input checked="" type="checkbox"/> Clock Data (Current): (4 Word)	[PLC1]D00002
<input checked="" type="checkbox"/> Status: (1 Word)	[PLC1]D00006
<input checked="" type="checkbox"/> Reserved (Write): (1 Word)	[PLC1]D00007
<input checked="" type="checkbox"/> Change-To Screen: (1 Word)	[PLC1]D00008
<input checked="" type="checkbox"/> Screen Display ON/OFF: (1 Word)	[PLC1]D00009
<input checked="" type="checkbox"/> Clock Data (Preset Value): (4 Word)	[PLC1]D00010
<input checked="" type="checkbox"/> Control: (1 Word)	[PLC1]D00014
<input checked="" type="checkbox"/> Reserved (Read): (1 Word)	[PLC1]D00015
<input type="checkbox"/> Window Control: (1 Word)	
<input type="checkbox"/> Window Screen: (1 Word)	
<input type="checkbox"/> Window Display Position: (2 Words)	

NOTE

- When using a Global Window, 4 Words are used for the [Window Control], [Window Screen], and [Window Display Position].

☞ "12.6 Changing the Displayed Window on All Screens" (page 12-18)

4 The settings are complete.

A.1.5 System Area (Memory Link Area)

When communicating inside the GP using the Memory Link Method, the System Area is secured. This area is used for exchanging with the host.

A.1.5.1 System Area List

Memory Link Method System Area

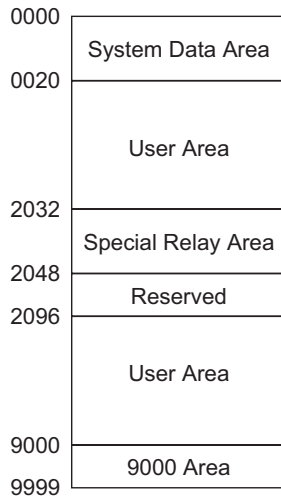

IMPORTANT

- When setting addresses for Parts in the System Data Area, set the data length as 16 bit.

Area Name	Description
System Data Area	This area stores data required for system operations, such as the GP screen control data and error information. The write data is fixed. ☞ "A.1.5.2 System Data Area" (page A-30)
User Area	This area is used for exchanging data between the GP and host computer. On the host, decide which GP address data to write and create a program to write the data. In the GP, configure settings for special Parts to display data written in the addresses. For the host to read written data by means of Switches, Data Displays, and keypads, you need to create a program in the host to read the GP's data.
Special Relay	This area stores each type of status information that occurs when the GP communicates. ☞ "A.1.5.3 Special Relay" (page A-38)
Reserved	Used inside the GP. Do not use this area. It will not operate normally.
9000 Area	Stores the GP's internal operating information such as a Trend Graph's historical data and the communication scan time. There is also an adjustable portion.

NOTE

- When the address has a bit designation, add a bit position after the Word device. (Designate from 00 to 15.)

<>When bit 02 of the user area's 0020 address is defined

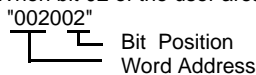

A.1.5.2 System Data Area

This shows the contents of write data in each address of the System Data Area.

IMPORTANT

- Normally, when turning OFF the Screen Display, do not use 11 (Control)'s "Backlight OFF" bit. Use 12 [Screen Display ON/OFF].

NOTE

- The Word Addresses in this table appear when you select the [Enable System Data Area] check box and all of the items.

Word Address	Description	Bit	Details
0	Reserved	-	Reserved
1	Status	0 to 1	Reserved
		2	Printing
		3	Data Display Part Write Setting Value
		4 to 7	Reserved
		8	Data Display Part Input Error
		9	Display ON/OFF 0:ON, 1:OFF
		10	Detect Backlight Burnout
		11 to 15	Reserved
2	Reserved	-	Reserved
3	Error Status	0 to 2	Unused
		3	Screen Memory Checksum
		4	SIO Framing
		5	SIO Parity
		6	SIO Overrun
		7 to 9	Unused
		10	Backup Battery Low Voltage
		11 to 15	Unused
4	Clock's current "Year" value	0 to 7	Last digits of year (2 BCD digits)
		8 to 15	Unused
5	Clock's current "Month" value	0 to 7	01 to 12 (2 BCD digits)
		8 to 15	Unused
6	Clock's current "Day" value	0 to 7	01 to 31 (2 BCD digits)
		8 to 15	Unused
7	Clock's current "Hour" value	0 to 7	00 to 23 (2 BCD digits)
		8 to 15	Unused

Continued

Word Address	Description	Bit	Details
8	Clock's current "Minute" value	0 to 7	00 to 59 (2 BCD digits)
		8 to 15	Unused
9	Reserved	-	Reserved
10	Interrupt Output (When touch is OFF)	-	If writing to a Word Switch (16 bit), when you take your finger off the Switch, the bottom 8 bits are output as an interrupt code.*1
11	Control	0	Backlight OFF
		1	Buzzer ON
		2	Print Started
		3	Reserved
		4	Buzzer
		5	AUX Output
		6	Writes "FFh" when you touch a screen and return to the screen (from "Display OFF" to "Display ON"). 0: Do not output interrupt 1: Output interrupt
		7 to 10	Reserved
		11	Print Canceled
		12 to 15	Reserved
12	Screen Display ON/OFF	-	Turn Screen Display OFF with FFFFh Display screen with 0h
13	Interrupt Output (When touch is ON)	-	When writing to a Word Switch (16 bit), the bottom 8 bits are output as an interrupt code.*1
14	Reserved	-	Reserved
15	Current Screen Number	-	1 to 9999 (BIN) 1 to 7999 (BCD)*2
16	Window Control	0	Window Display 0: OFF, 1: ON
		1	Change Window overlap order 0: Permitted, 1: Not permitted
		12 to 15	Reserved
17	Window Number	-	Global Window's registration number selected indirectly: 1 to 2000 (BIN/BCD).

Continued

Word Address	Description	Bit	Details
18	Window Display Position (X Coordinate)	-	Global Window's top-left display position, selected indirectly (BIN/BCD).
19	Window Display Position (Y Coordinate)	-	

- *1 When you write data 0x00 to 0x1F, communications problem may occur. This is unaffected by [System Settings] workspace, [Display Unit] screen's [Touch Panel Detection] setting. Word address 10 interrupts output on release (when touch is OFF) and word address 13 interrupts outputs on touch (when touch is ON). The buzzer on the switch sounds to inform the operator the operation is executing. Therefore, by setting up addresses 10 and 13 to one switch using the [Multifunction List], the buzzer sounds whenever touch turns ON and touch turns OFF.
- *2 When you do not specify [Reflect in Device/PLC] from the [System Settings] [Display Unit] [Display] tab, you cannot return to the screen number from which you switched by touch from the host. To force the screen to switch, turn ON bit 15 of the address, specify the screen number to which you want to switch from bits 0 -14. (Input the 8000h + the value of screen number to which you want to switch in the address.

For example, to enable forced screen switching:



8000(h)+1999(h)=9999(h) write "9999" to the address.

Caution:

- While forced screen switching is enabled (Bit 15 is ON), screen switching by touch is not
- When the data format is BCD, you cannot change to screens numbered 2000 or higher.

Description	Details		
Reserved	Addresses "0", "2", "9", and "14" are reserved.  Because they are used by the GP, please do not write data to these addresses. It may not work properly.		
Status	Monitor only the necessary bits. Reserved bits are sometimes used for GP system maintenance, so do NOT turn them ON/OFF.		
	Bit	Description	Details
	0,1	Reserved	-
	2	Printing	Turns ON during printing. While this bit is ON, there are cases when the offline screen appears or when output is disturbed.
	3	Write Setting Value	This bit is reversed each time a write occurs from a Data Display (Setting Value Input).
	4 to 7	Reserved	-
	8	Data Display Part Input Error	When Alarms are set for the Data Display where you enter a value outside of the alarm range, this bit turns ON. When you input a value inside the alarm range or change screens, this bit turns OFF.
	9	Display ON/OFF (0: ON, 1: OFF)	This can detect whether to turn the GP's screen display ON/OFF from the device/PLC. This bit changes in the following cases. When FFFFh is written to the System Data Area's Display ON/OFF, the display turns OFF. When the standby time passes, the display turns OFF If the screen changes or is touched after the display turns OFF, the display turns back ON.
	10	Detect Backlight Burnout	When an expired backlight is detected, this bit turns ON.
	11 to 15	Reserved	-







Continued

Description	Details																											
Error Status	<p>When an error occurs in the GP, the corresponding bit turns ON. After the bit turns ON and the power turns OFF, the status is maintained until the GP changes from offline mode back to active mode.</p> <table border="1" data-bbox="388 285 1256 681"> <thead> <tr> <th>Bit</th> <th>Description</th> <th>Details</th> </tr> </thead> <tbody> <tr> <td>0 to 2</td> <td>Unused</td> <td></td> </tr> <tr> <td>3</td> <td>Screen Memory Checksum</td> <td>There is an error in the project file. Transfer it again.</td> </tr> <tr> <td>4</td> <td>SIO Framing</td> <td></td> </tr> <tr> <td>5</td> <td>SIO Parity</td> <td></td> </tr> <tr> <td>6</td> <td>SIO Overrun</td> <td></td> </tr> <tr> <td>7 to 9</td> <td>Unused</td> <td></td> </tr> <tr> <td>10</td> <td>Backup Battery Low Voltage</td> <td>This turns ON when the voltage of the backup lithium battery is low. The backup battery is used by the clock and SRAM.</td> </tr> <tr> <td>11 to 15</td> <td>Unused</td> <td></td> </tr> </tbody> </table> <p> Because the addresses are used for system control, do not display them by means of a Data Display.</p>	Bit	Description	Details	0 to 2	Unused		3	Screen Memory Checksum	There is an error in the project file. Transfer it again.	4	SIO Framing		5	SIO Parity		6	SIO Overrun		7 to 9	Unused		10	Backup Battery Low Voltage	This turns ON when the voltage of the backup lithium battery is low. The backup battery is used by the clock and SRAM.	11 to 15	Unused	
Bit	Description	Details																										
0 to 2	Unused																											
3	Screen Memory Checksum	There is an error in the project file. Transfer it again.																										
4	SIO Framing																											
5	SIO Parity																											
6	SIO Overrun																											
7 to 9	Unused																											
10	Backup Battery Low Voltage	This turns ON when the voltage of the backup lithium battery is low. The backup battery is used by the clock and SRAM.																										
11 to 15	Unused																											
Clock Data (Current)	<p>Whatever the value, it will be stored in BCD, in the highest-order bit to bit 7. [Year] is the 2 final digits of the year, [Month] is 2 digits from 01 to 12, [Day] is 2 digits from 01 to 31, [Hours] is 2 digits from 00 to 23 and [Minutes] is 2 digits from to 59.</p> <p>■ For example, < October 19, 2005, 21:57 ></p> <ul style="list-style-type: none"> - "Year" - Write "0005" Word Address "4" - "Month" - Write "0010" Word Address "5" - "Day" - Write "0019" Word Address "6" - "Hour" - Write "0021" Word Address "7" - "Minute" - Write "0057" Word Address "8" 																											
Interrupt Output (When touch is OFF)	<p>If writing to a Word Switch (16 bit), when you take your finger off the Switch, the bottom 8 bits are output as an interrupt code. (Control code "FFh" will not be outputted.)</p> <p> Do not write control codes in the "00 to 1F" range. It can cause a communication problem.</p>																											





Continued

Description	Details		
Control	<p>NOTE</p> <ul style="list-style-type: none"> • Please make sure to write this address in bit units. In some cases, writing with word data can change the value. • "Reserved" bits are sometimes used for maintenance of the GP's system. Turn them OFF. 		
	Bit	Description	Details
	0	Backlight OFF	When ON, the backlight turns OFF. When OFF, the backlight turns ON. (The parts placed on the screen function while the LCD is lit.) <p>NOTE</p> <ul style="list-style-type: none"> • Normally, when turning OFF the screen display, use Word Address "12" (Screen Display ON/OFF).
	1	Buzzer ON	0:Do not sound, 1: Sound
	2	Print Started	0:Do not sound, 1: Sound When the bit turns ON, the printing screen data starts. <p>NOTE</p> <ul style="list-style-type: none"> • When Status "Bit 2" (Printing) turns ON, turn it OFF manually.
	3	Reserved	0 Fixed
	4	Buzzer	The following action occurs only when Control "Bit 1" (Buzzer ON) is ON. 0:Sound, 1: Do not sound To stop the buzzer sound, turn this bit ON.
	5	AUX Output	The following action occurs only when Control "Bit 1" (Buzzer ON) is ON. 0:Sound, 1: Do not sound To stop the AUX output, turn this bit ON.
	6	Interrupt output for when a screen is changed from OFF to ON by touching a touch panel	(Interrupt code: FFh) 0: Do not output interrupt, 1: Output interrupt
	7 to 10	Reserved	0 Fixed
	11	Print Canceled	0:Sound, 1: Do not sound When the bit turns ON, all current printing is canceled. <p>NOTE</p> <ul style="list-style-type: none"> • After printing stops and Status "Bit 2" (Printing) turns OFF, turn it OFF manually. • Even when the Print Canceled bit turns ON, data previously sent to the printer is printed.
	12 to 15	Reserved	0 Fixed

Continued

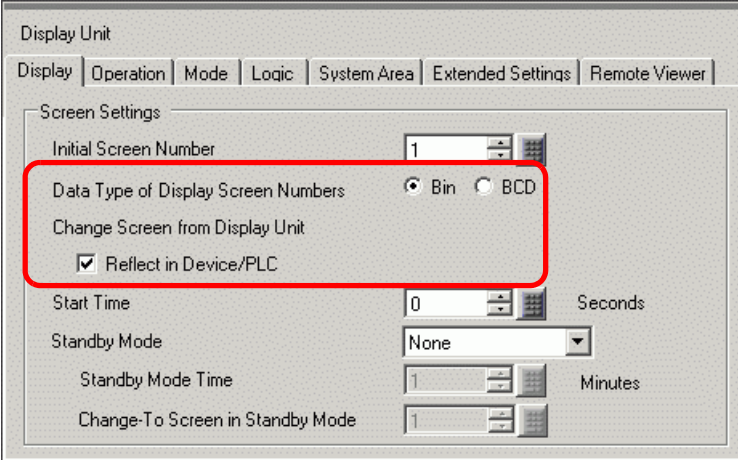
Description	Details
Screen Display ON/OFF	<p>Shows the screen when the value is "0h" and hides the screen when the value is "FFFFh". Values other than "0h" and "FFFFh" are reserved. When the screen display is hidden, the next touch on the screen will turn the display back ON.</p> <ul style="list-style-type: none">  Because the addresses are used for system control, do not display them by means of a Data Display.  Because the addresses are controlled in Words, you cannot write Bits.  When you write "FFFFh," the displayed screen disappears momentarily. If you want the screen display to disappear for the standby mode time designated in the GP offline mode's initial settings, write "0000h."
Interrupt Output (When touch is ON)	<p>When writing to a Word Switch (16 bit), the lower 8 bits are output from the GP to the host as an interrupt code.</p> <ul style="list-style-type: none">  Do not write control codes in the "00 to 1F" range. It can cause a communication problem.  Because the addresses are used for system control, do not display them by means of a Data Display.  Because the addresses are controlled in Words, you cannot write Bits. <p>NOTE</p> <ul style="list-style-type: none"> • When you write data with a Word Switch (16 bit), they are output as interrupt data. Retrieve this byte of interrupt input in the host (with the INPUT\$ in BASIC, for example), and you can simplify the program by using the retrieved interrupt output to jump to each subroutine.

Continued

Description	Details																		
<p>Current Screen Number</p>	<p>Set the Change-to Screen Number. The setting range differs depending on whether or not [Data Type of Display Screen Numbers] and [Change Screen from Display Unit - Reflect in Device/PLC] are set on the [System Settings] [Display Unit] [Display] tab.</p>  <p>When [Data Type of Display Screen Numbers] is [Bin]:</p> <table border="1" data-bbox="400 865 1173 996"> <thead> <tr> <th>Reflect in Device/PLC</th> <th>Screen Change from Device/PLC</th> <th>Screen Change from Display Unit</th> </tr> </thead> <tbody> <tr> <td>Enable</td> <td>1 to 9999</td> <td>1 to 9999</td> </tr> <tr> <td>Disable</td> <td>1 to 9999</td> <td>1 to 9999</td> </tr> </tbody> </table> <p>When [Data Type of Display Screen Numbers] is [BCD]:</p> <table border="1" data-bbox="400 1072 1173 1203"> <thead> <tr> <th>Reflect in Device/PLC</th> <th>Screen Change from Device/PLC</th> <th>Screen Change from Display Unit</th> </tr> </thead> <tbody> <tr> <td>Enable</td> <td>1 to 7999</td> <td>1 to 7999</td> </tr> <tr> <td>Disable</td> <td>1 to 1999</td> <td>1 to 7999</td> </tr> </tbody> </table> <ul style="list-style-type: none">  Because the addresses are used for system control, do not display them by means of a Data Display.  Because the addresses are controlled in Words, you cannot write Bits. 	Reflect in Device/PLC	Screen Change from Device/PLC	Screen Change from Display Unit	Enable	1 to 9999	1 to 9999	Disable	1 to 9999	1 to 9999	Reflect in Device/PLC	Screen Change from Device/PLC	Screen Change from Display Unit	Enable	1 to 7999	1 to 7999	Disable	1 to 1999	1 to 7999
Reflect in Device/PLC	Screen Change from Device/PLC	Screen Change from Display Unit																	
Enable	1 to 9999	1 to 9999																	
Disable	1 to 9999	1 to 9999																	
Reflect in Device/PLC	Screen Change from Device/PLC	Screen Change from Display Unit																	
Enable	1 to 7999	1 to 7999																	
Disable	1 to 1999	1 to 7999																	
<p>Window Screen Control</p>	<p>Controls the window display.  "12.7.2 Word Action" (page 12-24)</p>																		
<p>Window Number</p>	<p>Stores the Global Window's registration number selected indirectly: 1 to 2000 (BIN/BCD).</p>																		
<p>Window Display Position</p>	<p>Stores the Global Window's top-left display position, selected indirectly. "+18" shows the X coordinate, "+19" shows the Y coordinate. The data type is BIN or BCD.</p>																		

A.1.5.3 Special Relay

- ⊘ The Special Relay is not write-protected. Do not turn it ON/OFF with Parts or write Words.

The Special Relay has the following structure.

Memory Link Method

Address	Description
2032	Common Relay Information
2033	Base Screen Information
2034	Reserved
2035	1-Second Binary Counter
2036	Display Scan Time
2037	Reserved
2038	Display scan counter
2039	Reserved
2040	Reserved
2041	
2042	
2043	
2044	
2045	
2046	
2047	

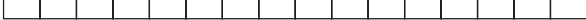
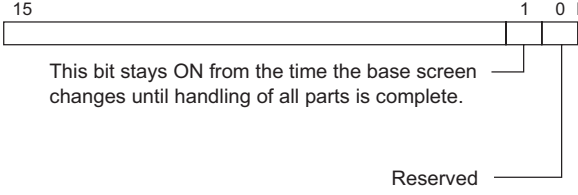
Description	Details																																		
<p>Common Relay Information</p>	<div style="text-align: center;"> <p>15 14 13 12 11 10 9 8 7 6 5 4 3 2 1 0 Bit</p>  </div> <table border="1" data-bbox="392 305 1252 1367"> <thead> <tr> <th>Bit</th> <th>Description</th> </tr> </thead> <tbody> <tr> <td>0</td> <td>Reserved</td> </tr> <tr> <td>1</td> <td>After a screen (Base, Window) changes, turns ON until the Part handling is complete.</td> </tr> <tr> <td>2</td> <td>Reserved</td> </tr> <tr> <td>3</td> <td>Turns ON while the initial screen displays at power ON.</td> </tr> <tr> <td>4</td> <td>Normally ON.</td> </tr> <tr> <td>5</td> <td>Normally OFF.</td> </tr> <tr> <td>6</td> <td>Turns ON when backup SRAM data is erased. (Only onboard backup SRAM)</td> </tr> <tr> <td>7</td> <td>When using D-Scripts, turns ON when a BCD error occurs.</td> </tr> <tr> <td>8</td> <td>When using D-Scripts, turns ON when a zero error occurs.</td> </tr> <tr> <td>9</td> <td>Turns ON when a recipe could not be transferred to backup SRAM.</td> </tr> <tr> <td>10</td> <td>Turns ON when filing data transferred according to the Control Word Address could not be transferred from PLC*1. Also, if transferring between the PLC by means of a Special Data Display, when there is a Transfer Complete Bit Address, turns ON when data could not be transferred from PLC*1 Area, or PLC*1 SRAM.</td> </tr> <tr> <td>11</td> <td>Turns ON while transferring filing data between SRAM LS Area*1 by means of a Special Data Display (Filing).</td> </tr> <tr> <td>12</td> <td>When using D-Scripts, turns ON when a communication error occurs from a memcpy () or address offset designation read. Turns OFF when data finishes reading normally.</td> </tr> <tr> <td>13</td> <td>In the [System Settings] [Script I/O] page, when no [D-Script/Global D-Script] is set in the project, turns ON when the readout of the Send function, Receive function, Control, Status variable, and Received Data Size is executed in [SIO Port Operation]'s Label Settings.</td> </tr> <tr> <td>14</td> <td>In the [System Settings] [Script I/O] page, when [D-Script/Global D-Script] is set in the project, turns ON when an extended script's [Text Operation] function is executed. Also, in the [System Settings] [Script I/O] page, when [Extended Script] is set in the project, turns ON even when a D-Script/Global D-Script [SIO Port Operation]'s I/O function (IO_WRITE, IO_READ) is executed.</td> </tr> <tr> <td>15</td> <td>Reserved</td> </tr> </tbody> </table> <p>*1 For the Memory Link Method, represents the "User Area" inside the System Area.</p>	Bit	Description	0	Reserved	1	After a screen (Base, Window) changes, turns ON until the Part handling is complete.	2	Reserved	3	Turns ON while the initial screen displays at power ON.	4	Normally ON.	5	Normally OFF.	6	Turns ON when backup SRAM data is erased. (Only onboard backup SRAM)	7	When using D-Scripts, turns ON when a BCD error occurs.	8	When using D-Scripts, turns ON when a zero error occurs.	9	Turns ON when a recipe could not be transferred to backup SRAM.	10	Turns ON when filing data transferred according to the Control Word Address could not be transferred from PLC*1. Also, if transferring between the PLC by means of a Special Data Display, when there is a Transfer Complete Bit Address, turns ON when data could not be transferred from PLC*1 Area, or PLC*1 SRAM.	11	Turns ON while transferring filing data between SRAM LS Area*1 by means of a Special Data Display (Filing).	12	When using D-Scripts, turns ON when a communication error occurs from a memcpy () or address offset designation read. Turns OFF when data finishes reading normally.	13	In the [System Settings] [Script I/O] page, when no [D-Script/Global D-Script] is set in the project, turns ON when the readout of the Send function, Receive function, Control, Status variable, and Received Data Size is executed in [SIO Port Operation]'s Label Settings.	14	In the [System Settings] [Script I/O] page, when [D-Script/Global D-Script] is set in the project, turns ON when an extended script's [Text Operation] function is executed. Also, in the [System Settings] [Script I/O] page, when [Extended Script] is set in the project, turns ON even when a D-Script/Global D-Script [SIO Port Operation]'s I/O function (IO_WRITE, IO_READ) is executed.	15	Reserved
Bit	Description																																		
0	Reserved																																		
1	After a screen (Base, Window) changes, turns ON until the Part handling is complete.																																		
2	Reserved																																		
3	Turns ON while the initial screen displays at power ON.																																		
4	Normally ON.																																		
5	Normally OFF.																																		
6	Turns ON when backup SRAM data is erased. (Only onboard backup SRAM)																																		
7	When using D-Scripts, turns ON when a BCD error occurs.																																		
8	When using D-Scripts, turns ON when a zero error occurs.																																		
9	Turns ON when a recipe could not be transferred to backup SRAM.																																		
10	Turns ON when filing data transferred according to the Control Word Address could not be transferred from PLC*1. Also, if transferring between the PLC by means of a Special Data Display, when there is a Transfer Complete Bit Address, turns ON when data could not be transferred from PLC*1 Area, or PLC*1 SRAM.																																		
11	Turns ON while transferring filing data between SRAM LS Area*1 by means of a Special Data Display (Filing).																																		
12	When using D-Scripts, turns ON when a communication error occurs from a memcpy () or address offset designation read. Turns OFF when data finishes reading normally.																																		
13	In the [System Settings] [Script I/O] page, when no [D-Script/Global D-Script] is set in the project, turns ON when the readout of the Send function, Receive function, Control, Status variable, and Received Data Size is executed in [SIO Port Operation]'s Label Settings.																																		
14	In the [System Settings] [Script I/O] page, when [D-Script/Global D-Script] is set in the project, turns ON when an extended script's [Text Operation] function is executed. Also, in the [System Settings] [Script I/O] page, when [Extended Script] is set in the project, turns ON even when a D-Script/Global D-Script [SIO Port Operation]'s I/O function (IO_WRITE, IO_READ) is executed.																																		
15	Reserved																																		
<p>Base Screen Information (2033)</p>	<div style="text-align: center;"> <p>15 1 0 Bit</p>  <p>This bit stays ON from the time the base screen changes until handling of all parts is complete.</p> <p>Reserved</p> </div>																																		

Continued

Description	Details
Reserved (2034 - 2037) (2040 - 2047)	Values are undefined in reserved addresses. Do not use.
1-Second Binary Counter	Increments once every second immediately after the power is turned ON. The data is binary.
Display Scan Time (2036)	The display time starts from the first Part set on the display screen to the end of the last Part. Data is stored in binary format, with units in milliseconds. The data is updated when the targeted Parts' pre-processing completes. The data's initial value is "0". There is an error of ± 10 milliseconds.
Display Scan Counter	The counter increments each time the Part set on the display screen processes. The data is binary.

A.1.6 Restrictions

A.1.6.1 GP Internal Device Restrictions

- Data stored in the GP internal device, including Memory Link's System Area are deleted when the GP enters offline mode. However, you can copy the User Area's data to backup SRAM.
☞ "5.17.6 [System Settings] Setting Guide ■ [Display Unit] Settings Guide • Backup Internal Device" (page 5-165)

A.1.6.2 Special Relay Restrictions

- ⊘ A System Error may occur if a communication error continues for a long time. In this case, reset the GP.
- ⊘ When you use the value of a 1-Second Binary Counter or Display Scan Counter as the trigger bit for a Triggered Action part's Monitoring Bit or for the Script feature, a System Error may occur if a communication error continues for a long time. In this case, reset the GP.
- ⊘ The Special Relay is not write-protected. Do not turn it ON/OFF with Parts or write Words.

A.1.6.3 Restrictions when Using Direct Access and Memory Link Together

Using Direct Access Method and Memory Link Method, and Communicating with a Device/PLC

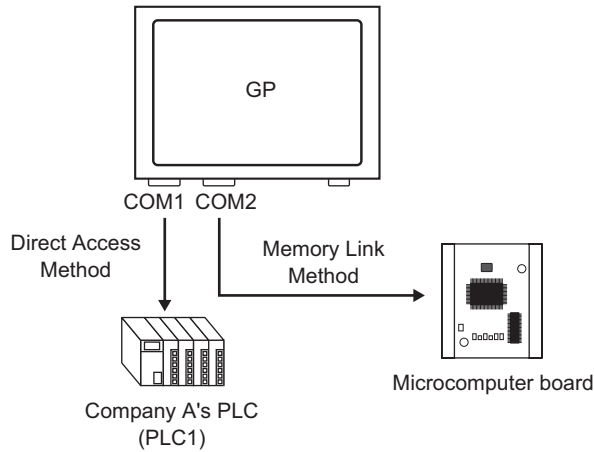

- When setting addresses with Parts or the Script feature, use the GP internal devices to distinguish between them.
For example, when setting a Word switch's [Word Address], when using GP internal devices you can select the 2 device code types below, but the supported communication methods differ depending on the address area.

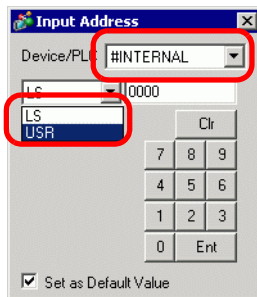

- [#INTERNAL]LS
The User Area allocated in the Device/PLC with the Direct Access Method. You cannot use the Memory Link Method to communicate.
- [#INTERNAL]USR
An area that can be arbitrarily set as a work area. Can be used with both the Direct Access Method and Memory Link Method.
- [#MEMLINK]
The User Area used only for communication by Memory Link Method. You cannot use the Direct Access Method to communicate.



- The Direct Access Method LS Area and the Memory Link Area (System Area) are mutually linked, with the exception of some addresses.

	Direct Access Method LS Area		Memory Link Method LS Area	
LS0000	System Data Area	Partly Linked	System Data Area	0000
LS0020	Read Area		User Area	0020
(LS0276)	User Area			
LS2032	Special Relay Area	Linked	Special Relay Area	2032
LS2048	Reserved Area		Reserved Area	2048
LS2096	User Area		User Area	2096
LS8192	User Area		User Area	8192
LS9000	LS9000 Area	Linked	LS9000 Area	9000
LS9999				

- The System Data Area in the Direct Access Method (LS Area) and the System Data Area in the Memory Link Area are partially linked. Please confirm the details in the corresponding table.

Description	Direct Access Method	Memory Link Method
Current Screen Number	LS0000	0015 (Read)
Error Status	LS0001	0003
Clock Data Current Value (Year)	LS0002	0004 (Read)
Clock Data Current Value (Month)	LS0003	0005 (Read)
Clock Data Current Value (Day)	LS0004	0006 (Read)
Clock Data Current Value (Time)	LS0005	0007, 0008 (Read)
Status	LS0006	0001
Reserved	LS0007	None
Change-To Screen	LS0008	0015 (Write)
Screen Display ON/OFF	LS0009	0012
Clock Data Preset Value (Year)	LS0010	0004 (Write)
Clock Data Preset Value (Month)	LS0011	0005 (Write)
Clock Data Preset Value (Day)	LS0012	0006 (Write)
Clock Data Preset Value (Time)	LS0013	0007, 0008 (Write)
Control	LS0014	0011
Reserved	LS0015	None
Window Control	LS0016	0016
Window Number	LS0017	0017
Window Display Position (X Coordinate)	LS0018	0018
Window Display Position (Y Coordinate)	LS0019	0019
Interrupt Output Data (When touch is OFF)	None	0010
Interrupt Output Data (When touch is ON)	None	0013

NOTE

- Some LS areas communicate with the device/PLC. For example, if [Change-To Screen Number] is changed to 3 (Memory Link Method address 0015) from a microcomputer board or other host, 3 is stored in Direct Access Method address LS0008, linked within the GP. Make sure the LS areas' operation will not be affected by these changes.

A.1.6.4 Restrictions when Using the USR Area

- The storage order for text data is as follows. You cannot change the order.

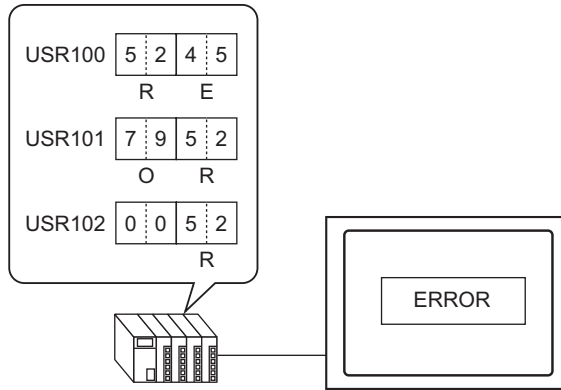

A.2 Monitoring the Value of Device Addresses (Device Monitor)

A.2.1 Introduction

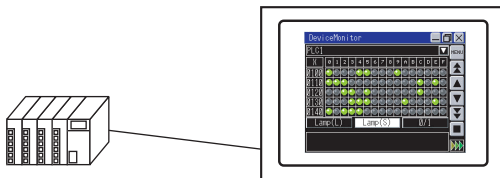

You can monitor the arbitrary device of a specified device/PLC on the GP screen and change the arbitrary address value from the GP screen. This is useful for debugging.

The screen for the monitor is provided, therefore you do not need to create the base screens.

The following devices/PLCs can use the device monitor feature.

Manufacturer	Device/PLC Name
Mitsubishi Electric Corporation	A Series CPU Direct
	A Series Ethernet
	A Series Calculator Link
	Q series CPU Direct
	Q/QnA Series Ethernet
	Q/QnA Serial Communication
	QnA Series CPU Direct
	FX Series CPU Direct
	FX Series Calculator Link
	QUTE Series CPU Direct
Omron Corporation	C/CV Series Upper Link
	CS/CJ Series Upper Link
	CS/CJ Series Ethernet
	Adjuster CompoWay/F
PROFIBUS International	PROFIBUS DP Slave
Siemens AG	SIMATIC S7 MPI Direct
	SIMATIC S7 3964(R)/RK512
	SIMATIC S7 Ethernet
	SIMATIC S5 CPU Direct
Rockwell Automation	DF1
	EtherNet/IP (Not including ControlLogix/ CompactLogix Series Native)
	DH-485

Continued

Manufacturer	Device/PLC Name
Yaskawa Electric Corporation	MEMOBUSSIO
	MEMOBUS Ethernet
	MP Series SIO (Extended)
	MP Series Ethernet (Extended)
Yokogawa Electric Corporation	PC Link SIO
	PC link Ethernet
JTEKT Corporation	TOYOPUC CMP-LINKSIO
	TOYOPUC CMP-LINK Ethernet
KEYENCE Corporation	KV-700/1000 Series CPUDirect
	KV-1000 Series Ethernet
	QnA Series CPU Direct
Schneider Electric Industries	MODBUS SIO Master
	MODBUS TCP Master
	Uni-Telway
	MODBUS Slave
	MODBUS Plus
Matsushita Electric Works, Ltd.	FP Series Computer Link SIO
Fuji Electric FA Components & Systems Co., Ltd.	MICREX-F Series SIO
	MICREX-SX Series SIO
	MICREX-SX Series Ethernet
Hitachi Industrial Equipment Systems Co., Ltd.	H Series SIO
	H Series Ethernet
Sharp MS Corporation	JW Series PC Link SIO
	JW Series PC Link Ethernet
RKC Instrument Inc.	Controller MODBUS SIO
	Temperature controller
Yamatake Corporation	Digital Controller SIO
GE Fanuc Automation	Series90 Ethernet
	Series 90-30/70 SNP
	Series 90-30/70 SNP-X
Mitsubishi Heavy Industries, Ltd.	DIASYS Netmation MODBUS TCP
	UP/V
LS Industrial Systems Co., Ltd.	MASTER-K Series Cnet
	XGT Series Fnet
Saia-Burgess Controls Ltd.	Saia S-Bus SIO
Meidensha Corporation., Ltd.	UNISEQUE Series Ethernet

Continued

Manufacturer	Device/PLC Name
FANUC Ltd.	Power Mate Series
ODVA	DeviceNet Slave
Hitachi, Ltd.	S10V Series Ethernet
	S10 series SIO
Shinko Technos Co., Ltd.	Controller SIO
Toshiba Machine Co., Ltd.	PROVISOR TC200
Toshiba Corporation	PC Link SIO
	Computer Link Ethernet
Koyo Electronics Industries Co., Ltd.	KOSTAC/DL Series CCM SIO
	KOSTAC/DL Series MODBUS TCP
CC-Link Partner Association	CC-Link Intelligent Device
IAI	ROBO Cylinder MODBUS SIO
FATEK AUTOMATION Corporation	FB Series SIO
CHINO	Controller MODBUS SIO
Modbus-IDA	General-purpose MODBUS RTU SIO Master
Hyundai Heavy Industries Co., Ltd.	Hi4 Robot

NOTE

- A ladder monitor tool is available for reading the PLC ladder program and monitoring on the GP screen. Please confirm whether your display model supports the ladder model features and purchase the ladder monitor tool for your PLC. Please refer to the "PLC Ladder Monitor Operation Manual" for the ladder monitor operating instructions.

☞ "1.3 Supported Features" (page 1-5)

A.2.2 Setup Procedure

Configure the following settings for the GP-Pro EX.

- 1 In the System Settings Window, click [Display Unit].



NOTE

- If the [System Settings] tab does not display on the work space, select the [View (V)] menu, point to [Work Space (W)], and then select [System Settings (S)].

- 2 Open the [Extended Settings] tab and select the [Device Monitor] check box.

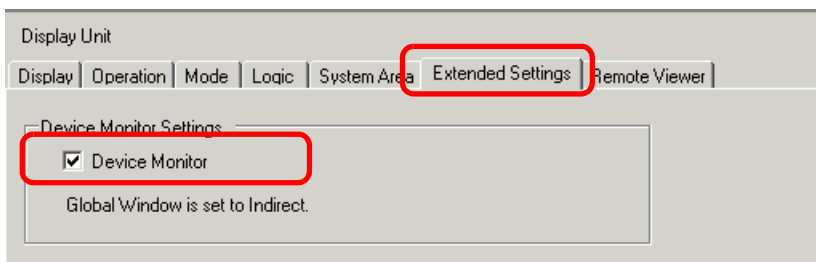

- 3 Transfer a project file to the GP.

NOTE

- The device monitor screen displays using a global window on the GP screen. Therefore, other global windows do not display while the device monitor executes.
- Enable [Device Monitor] to automatically specify [Global Window Operation] on the [Mode] tab as [Indirect].

A.2.3 Operating Procedure

■ Start the Device Monitor Screen

There are three ways to start the device monitor screen:

Start from the System Menu

- 1 Touch the top right corner, and then the bottom left corner (or bottom left corner top right corner) on the GP screen within 0.5 seconds.

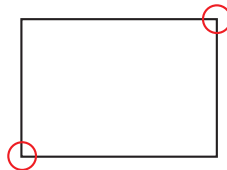

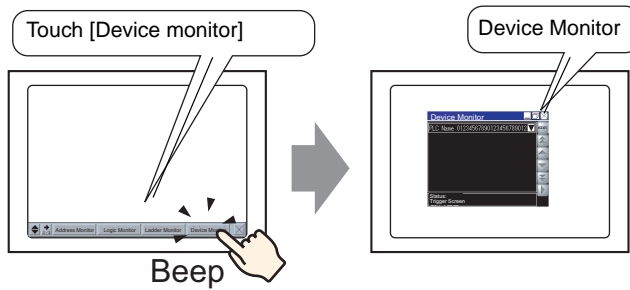

- 2 The system menu displays. Touch [Device Monitor] to display the device monitor screen.

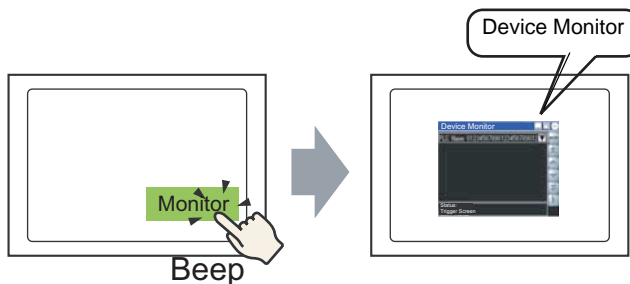

Start with a Switch to start the device monitor.

- 1 Create and place the switch for device monitor start in advance.



2 From the [Parts (P)] menu, point to [Switch/Lamp (C)] and select [Special Switch (P)] or click  to place the switch on the screen, and then set as follows.

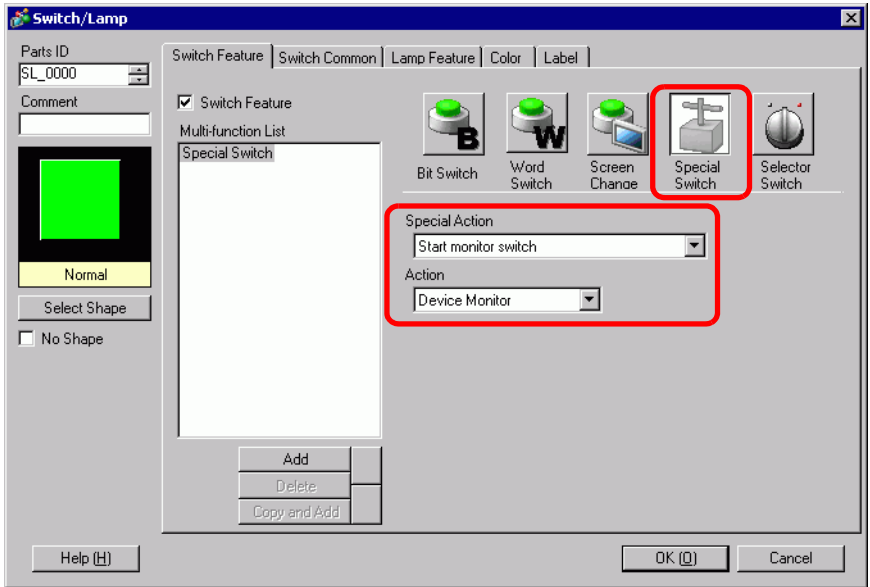

Triggering with System Variables

Turn ON the system variable #H_DeviceMonitor.

■ Monitor an Arbitrary Device

1 Select the monitoring method, and touch [Close Menu] or in the [Menu] bar touch .

The device monitor window becomes minimized.

Change the window size.

NOTE

- For models that support only QVGA resolution, you cannot change the window size.

Select a monitoring method.

Exit the device monitor.

Exit the menu screen.

Exit the device monitor.

Exit the menu screen.

Select to display/hide the device name.

Write the value to the arbitrary address. (page A-56)

2 The device monitor screen appears.

List of connectable device/PLCs is displayed.

Display the menu screen.

Previous page scrolling

Top line scrolling

Bottom line scrolling

Next page scrolling

Switches between monitor start and monitor stop

NOTE



- If text that is unusable on the GP is included in the device name, it will not display correctly.
- For changing which device to monitor, next to the device/PLC name touch . The names of devices you can monitor appears. Select the device to monitor.

◆ **Bit Block Monitor**

Displays all address states of the specified bit device in a list. You can select the display format for the bit state from either lamp display or 0/1 display.

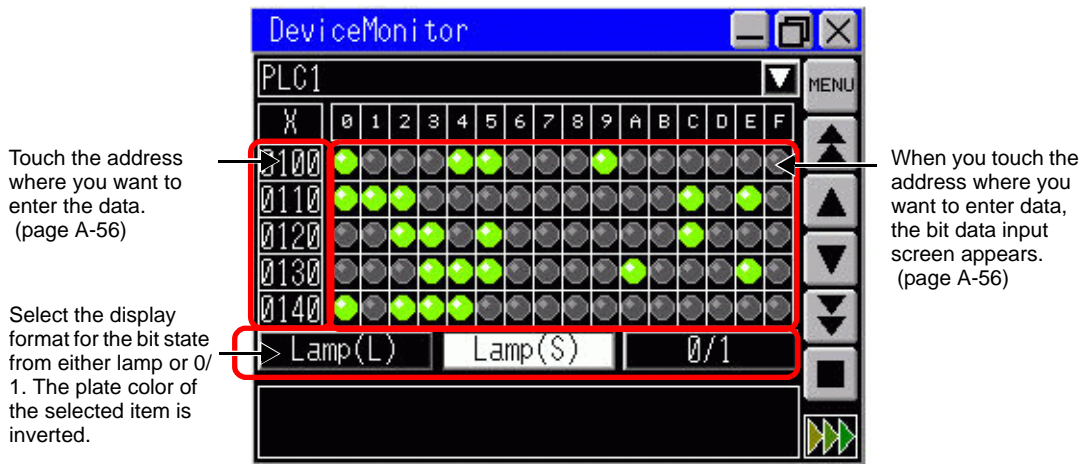
- 1 Touch [Bit Block Monitor] in the menu.
- 2 Touch the Exit menu or touch .
The Bit Block Monitor screen appears.



- 3 Select the display method from [Big Lamp], [Small Lamp] or [0/1]. When you select lamp display,  indicates ON and  indicates OFF.

◆ **Word Block Monitor**

Displays the current value of the selected word device.

- 1 Touch [Word Block Monitor] in the menu.
- 2 Touch the Exit menu or touch .
The Word Block Monitor screen appears.

- 3 Select the display format. The default setting is decimal. You can select from [Hexadecimal/BCD], [Unsigned],[Signed] or [Octal]. For a 32-bit device, you can also select [Float].

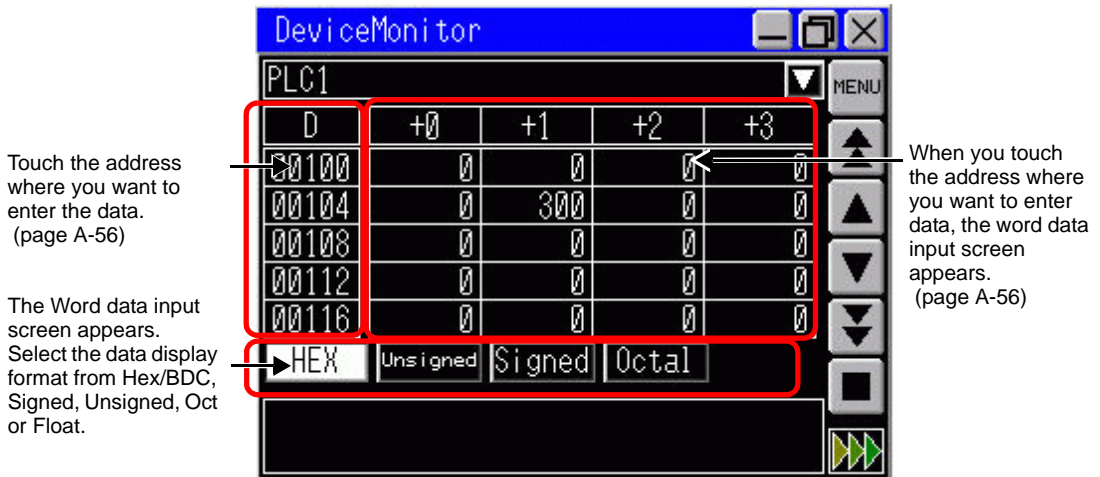

◆ Random Monitor

You can select and display the address that you want to monitor and the address that you want to view from the bit address.

NOTE

- In the random monitor, you can only view addresses that can display on one video. The address numbers that can display depend on the size of the display screen or device monitor screen.
- There is a limit to the number of characters you can display for the address. This limit is dependent on the screen size.

Window Size	Maximum Number of Single-Byte Characters
Small (320x240)	12
Medium (480x360)	34
Large (640x480)	14

- The address selected in the random monitor will be discarded when you turn off the power of the unit.

- 1 Touch [Random Monitor] in the menu screen.
- 2 Touch the Exit menu or touch . The Random Monitor screen appears.

3 Touch the any area of Type, Address or Format.

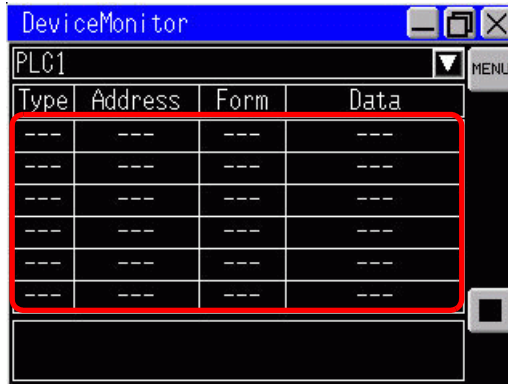

Touch the line to which you want to input the data.

4 Touch [Change] to move to the address input screen.

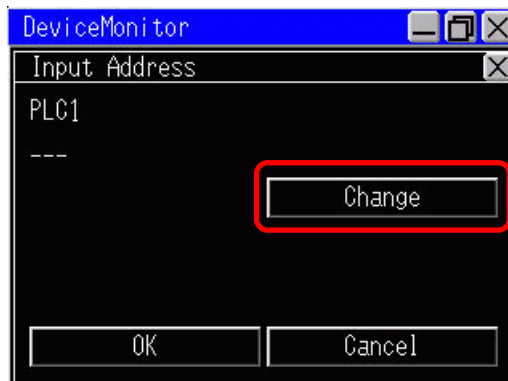

5 Enter the address you want to display and touch [ENT]. The screens will switch. Touch [OK] to display the input address on the random monitor screen.



◆ **Write to an Arbitrary Address**

You can write the value directly to an arbitrary address on the GP. The following procedure describes an example of writing the value "100" to the Word Address D100.

1 Touch [Write to Optional Address] on the menu screen. The address input screen displays.

NOTE • You can display the address input screen by touching the arbitrary address on each monitor screen.

2 Select [Word] from Type, specify the address as "D00000", and touch [ENT].

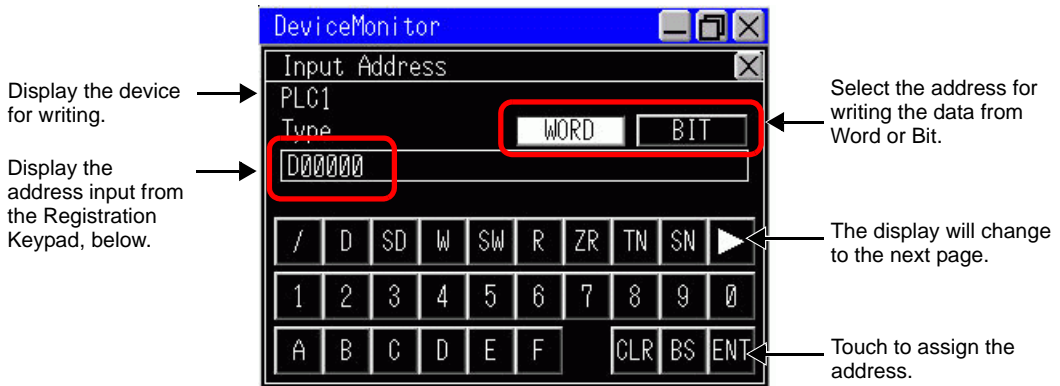

3 Select the display method for data, set the value "100" that you want to write, and touch [ENT].

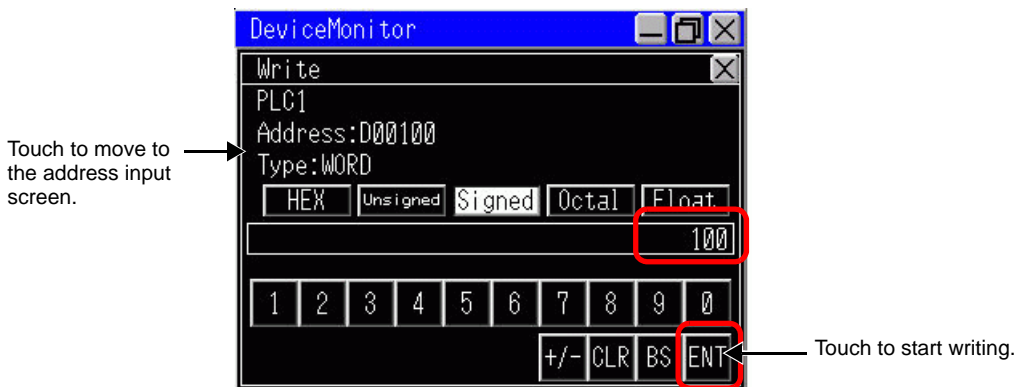

NOTE • When you write to a bit address, select [ON] or [OFF] and touch [ENT].

◆ **Minimize the Device Monitor Screen**

Touch  on the title bar to minimize and display on the bottom of the screen.

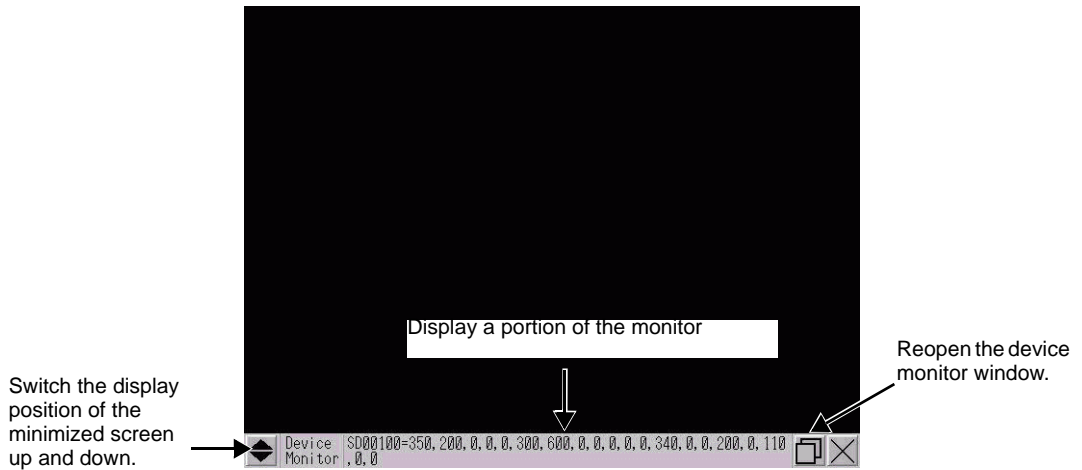

◆ **Moving the Display Position of the Display Monitor Screen**

NOTE

- You cannot use this feature when the display is the same size as the device monitor.

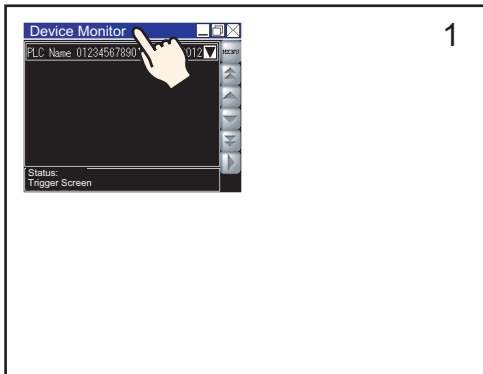

- 1 Touch the upper part of the device monitor screen.
- 2 Touch the desired position on the screen where you want the display to move.
- 3 The device monitor screen moves to the touched location.

NOTE

- If the device monitor screen runs off the screen in the selected location, the window is adjusted so that the entire window displays.

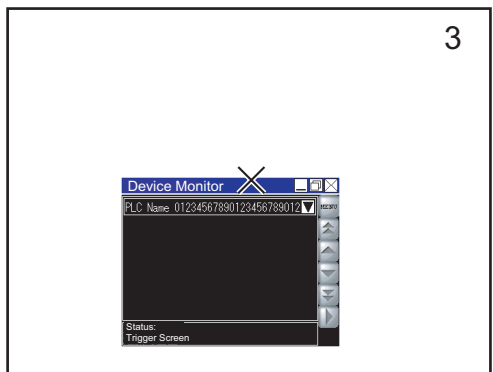
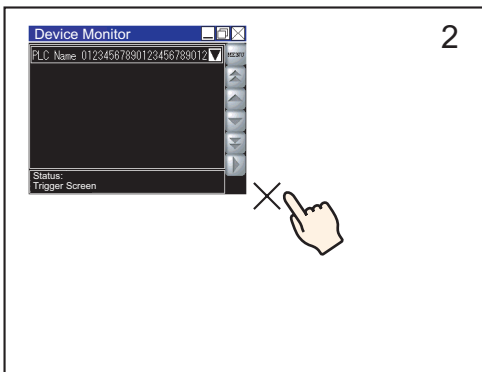

A.2.4 Restrictions

- The device monitor screen displays using a global window. You cannot display other global windows while the device monitor displays.
- When you turn off the power on the display unit, the display position and size settings for the device monitor or displayed items are lost.
- The bit display of a 32-bit device cannot display.
- The Word device cannot display binary.
- Do not write a value outside the range of the address. Doing so results in an error.
- The display language of the device monitor depends on the system language. If a language other than Japanese is specified, it is displayed in English. If an unusable language is set in the system language, the device/PLC name will not be displayed correctly.
- While using the device monitor, depending on the protocol or current screen size, screen updates could take longer than usual.
- For models that support only QVGA resolution, you cannot change the window size.

A.3 Executing Multiple Actions (Programs) with a Switch Operation

A.3.1 Trigger Action Parts Settings Guide

From the [Parts (P)] menu, select [Trigger Action]. The [Trigger Action List] dialog box appears. Click [Create] or [Edit] to display the following settings dialog box.

NOTE

- The component tray displays registered trigger action parts in the order they are created. To change the order of D-script parts in the component tray, change the ID number for registered parts, then from the [Edit] menu select [Auto-Align Trays]. You can change ID settings by double-clicking parts in the component tray to display the edit dialog box.

■ Bit Action

Operate the specified bit address according to the change of state of the trigger bit address.

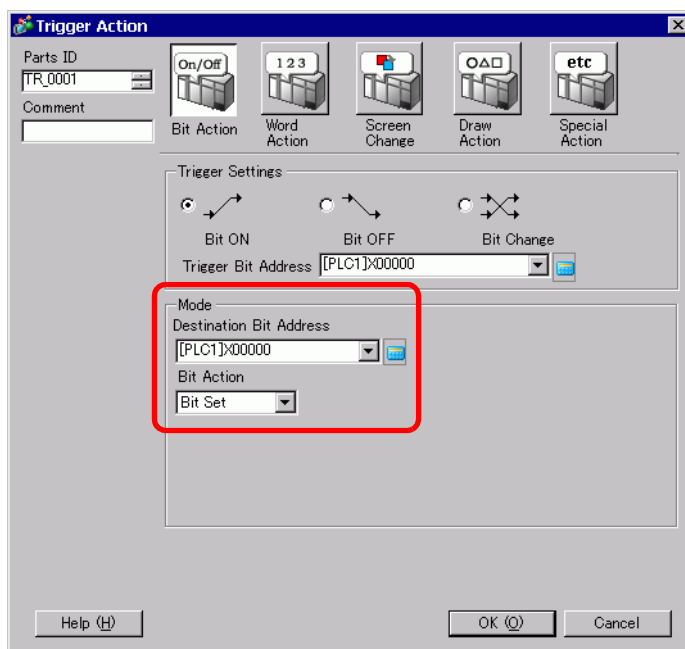

Setting		Description
Trigger Settings	Bit ON	Executes the action designated in [Mode] when the [Trigger Bit Address] changes from OFF ON.
	Bit OFF	Executes the action designated in [Mode] when the [Trigger Bit Address] changes from ON OFF.
	Bit Change	Executes the action designated in [Mode] when the [Trigger Bit Address] changes from ON to OFF or from OFF to ON.
	Trigger Bit Address	Designate the bit address that triggers the action set in [Mode].

Continued

Setting		Description													
Mode	Destination Bit Address	Designate the bit address to run the action.													
	Bit Action	Bit Set	Turns ON the [Destination Bit Address] and maintains the ON state.												
		Bit Reset	Turns OFF the [Destination Bit Address] and maintains the OFF state.												
		Bit Invert	Changes the ON/OFF state of the [Destination Bit Address].												
		Comparison	When the comparison condition is satisfied, turns ON the [Destination Bit Address]. Compares the Word Address data and a constant. <div data-bbox="510 517 1210 672" style="border: 1px solid gray; padding: 5px; width: fit-content; margin: 10px auto;"> <table style="width: 100%; border-collapse: collapse;"> <tr> <td style="border-bottom: 1px solid gray;">Comparison Word Address</td> <td style="border-bottom: 1px solid gray;">Condition</td> <td style="border-bottom: 1px solid gray;">Constant</td> </tr> <tr> <td style="border-bottom: 1px solid gray;">[PLC1]D00000</td> <td style="border-bottom: 1px solid gray;"><=</td> <td style="border-bottom: 1px solid gray;">300</td> </tr> <tr> <td colspan="2"></td> <td style="border-bottom: 1px solid gray;">Data Type</td> </tr> <tr> <td colspan="2" style="text-align: center;">D00000 <= 300</td> <td style="border-bottom: 1px solid gray;">Dec</td> </tr> </table> </div>	Comparison Word Address	Condition	Constant	[PLC1]D00000	<=	300			Data Type	D00000 <= 300		Dec
		Comparison Word Address	Condition	Constant											
	[PLC1]D00000	<=	300												
			Data Type												
D00000 <= 300		Dec													
Comparison Word Address	Define the Word Address to be compared.														
Condition	Select the comparison condition.														
Constant	Define the constant to be compared.														
Data Type	Choose the constant's data type from [Dec], [BCD], or [Hex].														

■ **Word Action**

Operate the specified bit address according to the change of state of the trigger bit address.

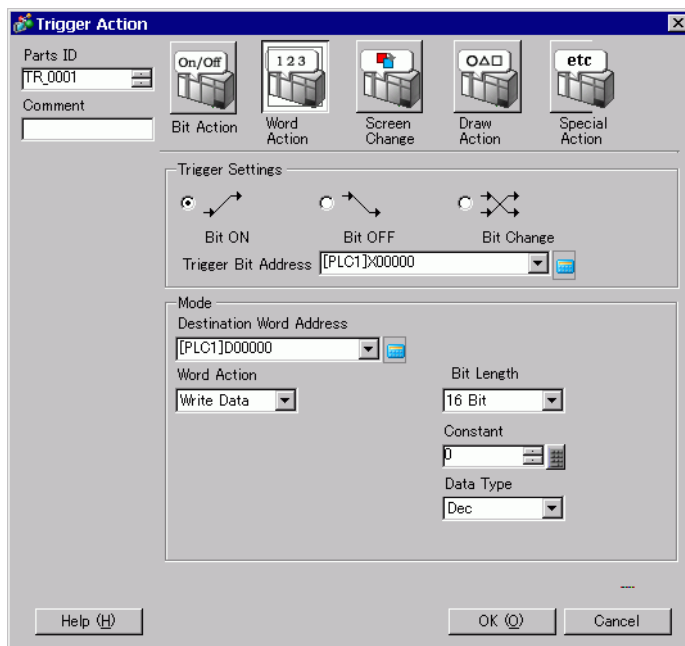

Setting		Description
Trigger Settings	Bit ON	Executes the action designated in [Mode] when the [Trigger Bit Address] changes from OFF to ON.
	Bit OFF	Executes the action designated in [Mode] when the [Trigger Bit Address] changes from ON to OFF.
	Bit Change	Executes the action designated in [Mode] when the [Trigger Bit Address] changes from ON to OFF or from OFF to ON.
	Trigger Bit Address	Designate the bit address that triggers the action set in [Mode].
Action	Destination Word Address	Designate the word address to run the action.

Continued

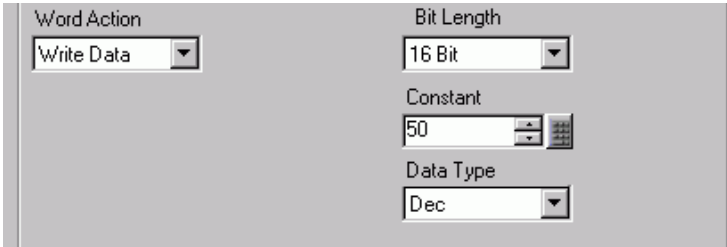
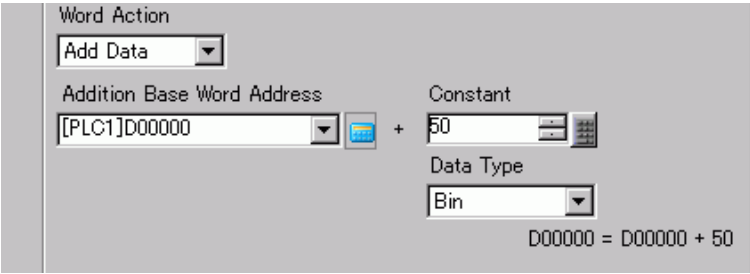
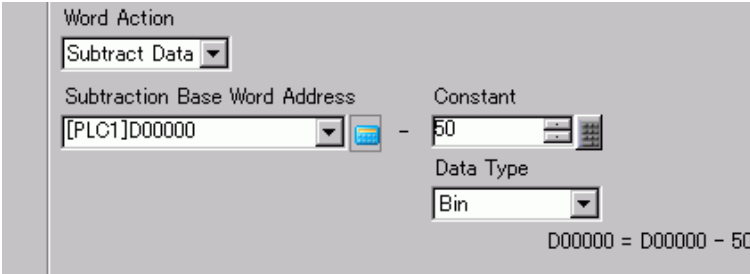
Setting		Description
Action	Word Action	Write Data Writes the constant in [Destination Word Address]. 
		Bit Length Set the data length for the Word address to 16 bit or 32 bit.
		Constant Designate the constant to write.
		Data Type Designate the constant's data type.
	Word Action	Add Data Writes the value of the constant added to the [Addition Base Word Address] into the [Destination Word Address]. 
		Addition Base Word Address Designate the Word Address to be added to the constant.
		Constant Designate the constant to add.
		Data Type Designate the constant's data type.
	Word Action	Subtract Data Writes the value of the [Subtraction Base Word Address] minus the constant into the [Destination Word Address]. 
		Subtraction Base Word Address Designate the Word Address from which the constant is subtracted.
		Constant Designate the constant to subtract.
		Data Type Designate the constant's data type.

■ Screen Change

Screen Change is executed according to the change of state of the trigger bit address.

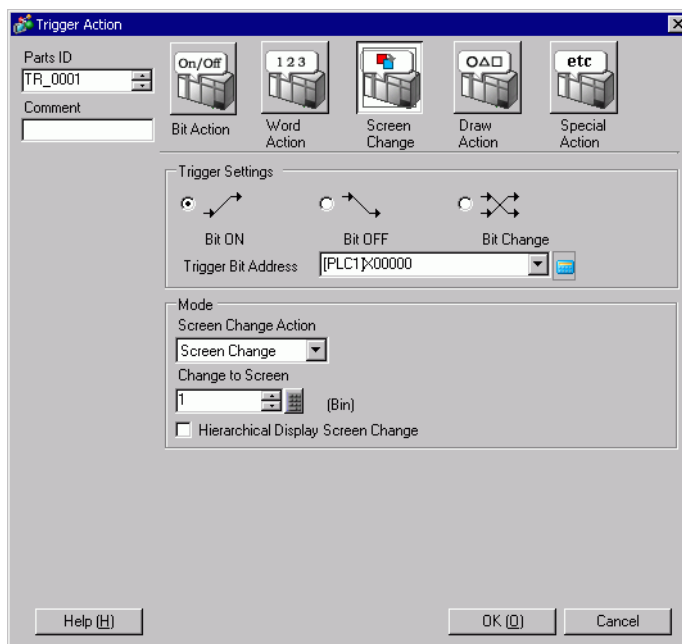

Setting		Description	
Trigger Settings	Bit ON	Executes the action designated in [Mode] when the [Trigger Bit Address] changes from OFF to ON.	
	Bit OFF	Executes the action designated in [Mode] when the [Trigger Bit Address] changes from ON to OFF.	
	Bit Change	Executes the action designated in [Mode] when the [Trigger Bit Address] changes from ON to OFF or from OFF to ON.	
	Trigger Bit Address	Designate the bit address that triggers the action set in [Mode].	
Action	Screen Change Action	Screen Change	The displayed screen changes to the specified screen.
		Change to Screen	Specify the number of the Screen you want to display from 1 to 9999. This can only be set when [Screen Change Action] is set to [Screen Change].
		Hierarchical Screen Change	You can set a level hierarchy to the Screen Change. When [Screen Change Action] is set to [Screen Change], can you define this setting. A maximum of 32 levels can be set.
	Previous Screen	Returns to the previously displayed screen. For screens that are organized hierarchically, the screen one level up (the parent screen) will reappear.	

■ Draw Action

When the trigger bit address turns ON, drawing action is executed.

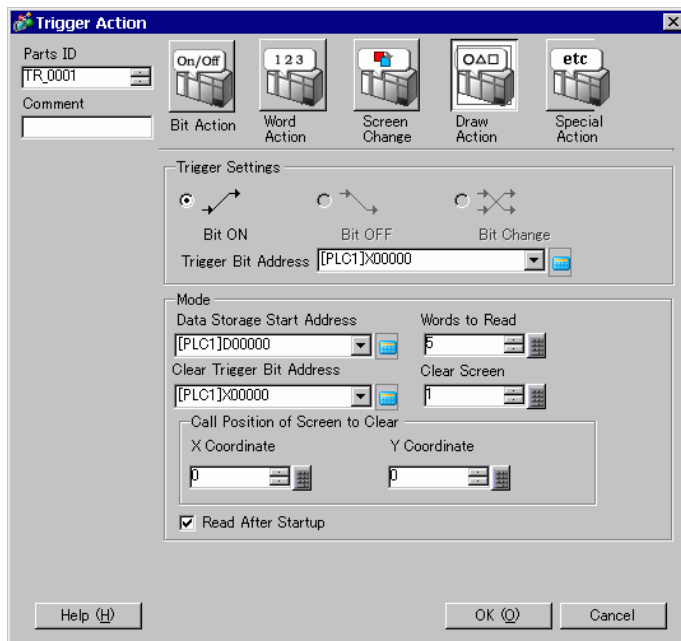

Setting		Description
Trigger Settings	Bit ON	Executes the action designated in [Mode] when the [Trigger Bit Address] changes from OFF to ON.
	Trigger Bit Address	Select the bit address that triggers the drawing of the image. NOTE <ul style="list-style-type: none"> • When the image displays, this turns OFF. • Please maintain graphical data while drawing.
Action	Data Storage Start Address	Stores the image and properties as graphical data in a Word address. Set this Word address' start address. ⚡ "◆ Draw Data" (page A-65)
	Words to Read	Specify the draw data words from 5 to 7.
	Clear Trigger Bit Address	Set a trigger bit to clear the drawn image. When the clearing bit turns ON, a Clearing Screen will overwrite the displayed screen. NOTE <ul style="list-style-type: none"> • When the Clearing Screen appears, this turns OFF.
	Clear Screen	Designate a Base screen to clear the drawn image. A Clearing Screen must first exist in the project.
	Clear Screen Calling Coordinate	Designate the Clearing Screen's call position using an X coordinate and a Y coordinate. NOTE <ul style="list-style-type: none"> • The top-left of the screen becomes coordinate (0, 0).

Continued

Setting		Description
Action	Read After Startup	<p>Reads the draw data when the conditions in [Trigger Settings] are satisfied.</p> <p>NOTE</p> <ul style="list-style-type: none"> This action cannot be used when the [Data Storage Word Address] is an internal device.

◆ Draw Data

Graphical data starting from the Data Storage Start Address is as follows.

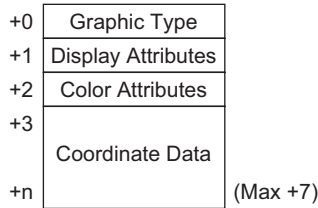

- Graphic Type (+0)

You can display a line, rectangle, circle, or dot. The following corresponding values will be stored.

Line: 1; Rectangle: 2; Circle: 3; Dot: 5

- Display Attributes (+1)

The display attributes, such as Line Type and Pattern, differ depending on each graphic. When drawing a dot, the display attributes (+1) data are ignored.



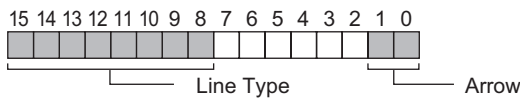







To draw a line

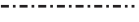

Arrow

Stored Value	Arrow
0	None
1	One Side
2	Both Ends

Line Type

Stored Value	Line Type	
0		(Solid Line: 1-dot thickness)
1		(Dashed Line: 1-dot thickness)
2		(Chain Line: 1-dot thickness)
3		(Two-Dot Chain Line: 1-dot thickness)
4		(Solid Line: 2-dot thickness)
5		(Dashed Line: 2-dot thickness)
6		(Chain Line: 2-dot thickness)
7		(Two-Dot Chain Line: 2-dot thickness)
8		(Solid Line: 3-dot thickness)
9		(Solid Line: 5-dot thickness)



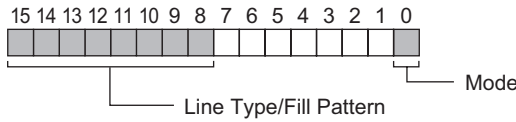











To draw a rectangle



Mode

Stored Value	Mode
0	Draw Line
1	Fill

Line Type/Fill Pattern

Stored Value	Line Type	Fill Pattern
0	 (Solid Line: 1-dot thickness)	
1	 (Dashed Line: 1-dot thickness)	
2	 (Chain Line: 1-dot thickness)	
3	 (Two-Dot Chain Line: 1-dot thickness)	
4		
5		
6		
7		
8		
9	 (Solid Line: 5-dot thickness)	



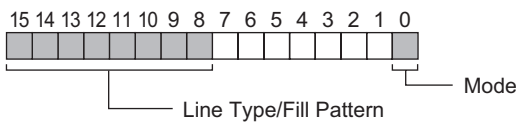









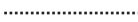



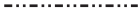



To draw a circle



Mode

Stored Value	Mode
0	Draw Line
1	Fill

Line Type/Fill Pattern

Stored Value	Line Type	Fill Pattern
0	 (Solid Line: 1-dot thickness)	
1	 (Dashed Line: 1-dot thickness)	
2	 (Chain Line: 1-dot thickness)	
3	 (Two-Dot Chain Line: 1-dot thickness)	
4		
5		
6		
7		
8	 (Solid Line: 3-dot thickness)	
9	 (Solid Line: 5-dot thickness)	

- Color Attributes (+2)

You can set the display color, background color, and blink settings. As shown below, display color data is stored in bit 0 to 7, and background color data are stored in bit 8 to 15.

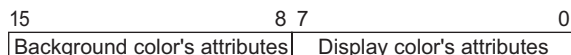

The format used to store attribute data differs depending on the following display colors and whether or not blink is set.

- 256 Color Display (No Blink)
- 64 Color Display + 3 Speed Blink
- Monochrome 16 Levels + 3 Speed Blink

For 256 Color Display (No Blink)

As shown below, display color data is stored in bits 0 to 7, and background color data are stored in bits 8 to 15. See the following for information about color codes.

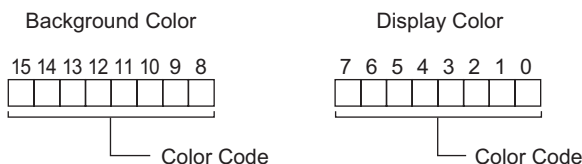

Color Code Table

Color Code	RGB Code	Color Code	RGB Code	Color Code	RGB Code	Color Code	RGB Code
0	00h	64	6Eh	128	CCh	192	A2h
1	01h	65	7Eh	129	DCh	193	B2h
2	02h	66	7Fh	130	DDh	194	B3h
3	03h	67	6Fh	131	CDh	195	A3h
4	04h	68	2Eh	132	C4h	196	AAh
5	05h	69	3Eh	133	D4h	197	BAh
6	06h	70	3Fh	134	D5h	198	BBh
7	07h	71	2Fh	135	C5h	199	ABh
8	10h	72	82h	136	8Ch	200	E2h
9	11h	73	92h	137	9Ch	201	F2h
10	20h	74	93h	138	9Dh	202	F3h
11	30h	75	83h	139	8Dh	203	E3h
12	31h	76	8Ah	140	84h	204	EAh
13	21h	77	9Ah	141	94h	205	FAh
14	22h	78	9Bh	142	95h	206	FBh
15	32h	79	8Bh	143	85h	207	EBh
16	33h	80	C2h	144	28h	208	EEh
17	23h	81	D2h	145	38h	209	FEh
18	12h	82	D3h	146	39h	210	FFh
19	13h	83	C3h	147	29h	211	EFh
20	40h	84	CAh	148	68h	212	E6h
21	50h	85	DAh	149	78h	213	F6h
22	51h	86	DBh	150	79h	214	F7h
23	41h	87	CBh	151	69h	215	E7h
24	60h	88	CEh	152	6Ch	216	A Eh
25	70h	89	DEh	153	7Ch	217	BEh
26	71h	90	DFh	154	7Dh	218	BFh
27	61h	91	CFh	155	6Dh	219	AFh
28	62h	92	C6h	156	2Ch	220	A6h
29	72h	93	D6h	157	3Ch	221	B6h
30	73h	94	D7h	158	3Dh	222	B7h
31	63h	95	C7h	159	2Dh	223	A7h
32	42h	96	8Eh	160	A0h	224	2Ah
33	52h	97	9Eh	161	B0h	225	3Ah
34	53h	98	9Fh	162	B1h	226	3Bh
35	43h	99	8Fh	163	A1h	227	2Bh
36	44h	100	86h	164	A8h	228	6Ah
37	54h	101	96h	165	B8h	229	7Ah
38	55h	102	97h	166	B9h	230	7Bh
39	45h	103	87h	167	A9h	231	6Bh
40	64h	104	0Ah	168	E0h	232	08h
41	74h	105	1Ah	169	F0h	233	18h
42	75h	106	1Bh	170	F1h	234	19h
43	65h	107	0Bh	171	E1h	235	09h
44	66h	108	4Ah	172	E8h	236	48h
45	76h	109	5Ah	173	F8h	237	58h
46	77h	110	5Bh	174	F9h	238	59h
47	67h	111	4Bh	175	E9h	239	49h
48	46h	112	4Eh	176	ECh	240	4Ch
49	56h	113	5Eh	177	FCh	241	5Ch
50	57h	114	5Fh	178	FDh	242	5Dh
51	47h	115	4Fh	179	EDh	243	4Dh
52	14h	116	0Eh	180	E4h	244	0Ch
53	15h	117	1Eh	181	F4h	245	1Ch
54	24h	118	1Fh	182	F5h	246	1Dh
55	34h	119	0Fh	183	E5h	247	0Dh
56	35h	120	C0h	184	ACH	248	90h
57	25h	121	D0h	185	BCh	249	91h
58	26h	122	D1h	186	BDh	250	81h
59	36h	123	C1h	187	ADh	251	88h
60	37h	124	C8h	188	A4h	252	98h
61	27h	125	D8h	189	B4h	253	99h
62	16h	126	D9h	190	B5h	254	89h
63	17h	127	C9h	191	A5h	255	80h

For 64 Colors + 3-Speed Blink

As shown below, display color data is stored in bits 0 to 5, and background color data are stored in bits 8 to 13. For information on color codes, refer to the 256-Color Code Table.

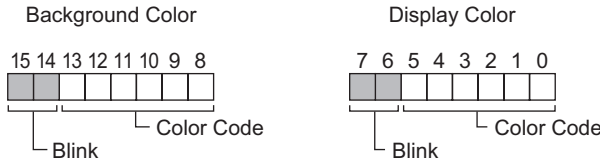

Blink Storage Values

Bit 7 Bit 15	Bit 6 Bit 14	Blink State
0	0	None
0	1	High Speed Blink
1	0	Medium Speed Blink
1	1	Low Speed Blink

For Monochrome 16 Levels + 3-Speed Blink

As shown below, display color data is stored in bits 0 to 3, and background color data are stored in bits 8 to 11. See the following for information about color codes.

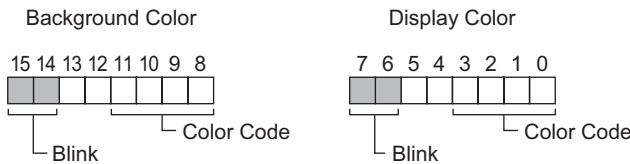

Color Code Table

Color Code	0	1	2	3	...	12	13	14	15	
Display Color	Black	→								White

Blink Storage Values

Bit 7 Bit 15	Bit 6 Bit 14	Blink State
0	0	None
0	1	High Speed Blink
1	0	Medium Speed Blink
1	1	Low Speed Blink

- Coordinate Data (+3)

For coordinate data, the top-left of the screen is coordinate (0, 0). For graphics in a window, the top-left of the screen registered as a window is coordinate (0, 0).

To draw a line

+3	Start Point X Coordinate
+4	Start Point Y Coordinate
+5	End Point X Coordinate
+6	End Point Y Coordinate

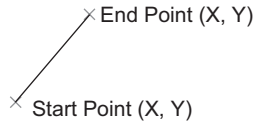

To draw a rectangle

+3	Start Point X Coordinate
+4	Start Point Y Coordinate
+5	End Point X Coordinate
+6	End Point Y Coordinate

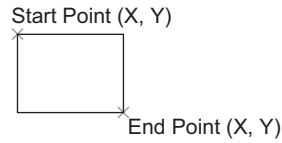

To draw a circle

+3	Center X Coordinate
+4	Center Y Coordinate
+5	Radius

Radius: 0 is invalid

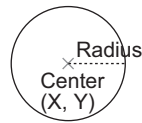

To draw a dot

+3	Center X Coordinate
+4	Center Y Coordinate



■ Special Action

Starts the application or exits WinGP depending on the change of state of the trigger bit address when using WinGP.

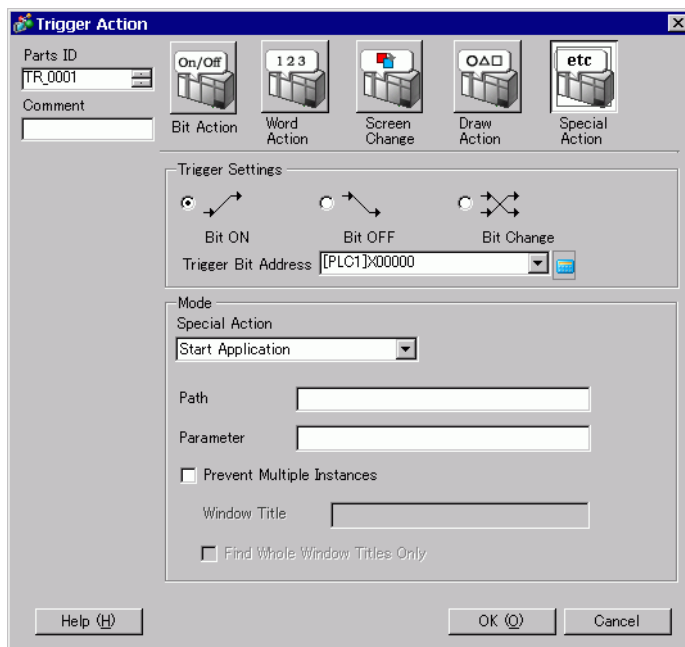

Setting		Description
Trigger Settings	Bit ON	Executes the action designated in [Mode] when the [Trigger Bit Address] changes from OFF to ON.
	Bit OFF	Executes the action designated in [Mode] when the [Trigger Bit Address] changes from ON to OFF.
	Bit Change	Executes the action designated in [Mode] when the [Trigger Bit Address] changes from ON to OFF or from OFF to ON.
	Trigger Bit Address	Designate the bit address that triggers the action set in [Mode].

Continued

Setting		Description
Action	Special Action	Select the action from [Start Application] or [Exit WinGP].
	Application Trigger	Specify the start up application on the WinGP.
	EXE path	Input the absolute path of the executable file (.EXE) you want to start. You can input up to 255 characters.
	Parameter	Input the argument of the executable file on start up. You can input up to 255 characters.
	Prevent multiple instances	If the specified application has already started, enable so application will not execute again if trigger conditions re-occur while the application is running. NOTE <ul style="list-style-type: none"> • If the specified application has already started, nothing will execute regardless of the settings you make.
	Window Title	Set [Window Title] to watch multiple instances. You can input up to 63 characters. When a window the same as [Window Title] is found, the specified application will not start. [Window Title], if there are no settings in this field, multiple starts are allowed.
	Find whole window titles only	When a window exactly the same as the title specified in [Window Title] is found, the specified application will not start.
	Exit WinGP	Display a confirmation dialog when exiting WinGP.
Display Confirmation Dialog Box		

NOTE

- When you select a series other than the IPC Series, the trigger action in [Special Action] will not operate regardless of your settings. [Special Action], to execute this operation, you need to start WinGP.

A.3.2 Trigger Action Restrictions

- For the trigger bit's ON/OFF, leave an interval longer than the communication cycle time^{*1} or display scan time^{*2}, whichever is longer.
- After you turn ON the Trigger Bit Address, if a screen change occurs before the drawing or erasing is complete, the Trigger Bit Address does not turn OFF.
- The only graphic data that can be stored is Bin data. BCD data cannot be used.
- If the graphical data to be stored is outside the range, it will default to zero.
- For coordinate data, the top-left of the screen is coordinate (0, 0). For graphics in a window, the top-left of the screen registered as a window is coordinate (0, 0).
- For the color attribute's background color, if you designate "Black + Medium Speed Blink" or color code 255, the background color will become transparent.
- The following shows actions which occur immediately after a screen is changed or power is turned ON.

Trigger Condition	Direct Access Method		Memory Link Method	
	Bit Value "0"	Bit Value "1"	Bit Value "0"	Bit Value "1"
0 to 1 (Bit Rising)	X	O	X	X
1 to 0 (Bit Falling)	O	X	X	X
0 to 1 (Bit State Change)	O	O	X	X

O: The operation is performed immediately after the screen is changed, or the power is turned ON.

X: The operation is not performed immediately after the screen is changed, or the power is turned ON.

*1 The Communication Cycle Time is the time from when the display unit requests data from the device/PLC, until the display unit receives the data. It is stored in the internal device LS2037 as binary data. The unit is milliseconds (ms). There is an error of ±10 ms.

*2 Display Scan Time is the time required to process one screen. It is stored in the internal device LS2036 as binary data. The unit is milliseconds (ms). There is an error of ±10 ms.

A.4 Drawing in Other Languages

A.4.1 Introduction

This section provides an example of how to create a switch label using a Chinese (Simplified) stroke font.

In addition to Chinese (Simplified), GP-Pro EX supports languages that use the ASCII character set, Chinese (traditional), Korean, Cyrillic, and Thai.



A.4.2 Setup Procedure

NOTE

- This procedure shows you how to use Chinese (Simplified) to enter a label for the screen change switch described in Section 12.2, "Changing the Display Screen by Touch". See that section for how to specify the settings for screen change switches.
 - ☞ "11.2 Changing Screens by Touch" (page 11-4)
- For more information on stroke fonts, see Section, "Stroke Font, Standard Font".
 - ☞ "6.2 Defining Stroke Font and Standard Font" (page 6-3)

For example, draw a switch label in Chinese (PRC).

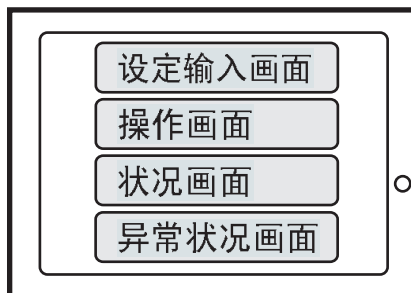

Run the following three types of settings. For each item, click the page number to read that section.

1. In the Windows Regional and Language Options, display the [Add Input language] dialog box and add the Chinese (PRC) keyboard

- " ◆ When using Windows®XP" (page A-75)
- " ◆ When using Windows®2000" (page A-77)

2. " ■ Adding Chinese (Simplified) Stroke Fonts to the Project" (page A-79)

3. " ■ Inputting Chinese (Simplified) into a Change Screen Switch Label" (page A-80)

■ In the Windows® Regional and Language Options, display the [Add Input language] dialog box and add the Chinese (PRC) keyboard

◆ When using Windows®XP

1 From the Windows XP [Control Panel], point to [Date, Time, Language, and Regional Options], and open the [Regional and Language Options] dialog box.

2 On the [Languages] tab, in [Text services and input languages], click the [Extended] button.

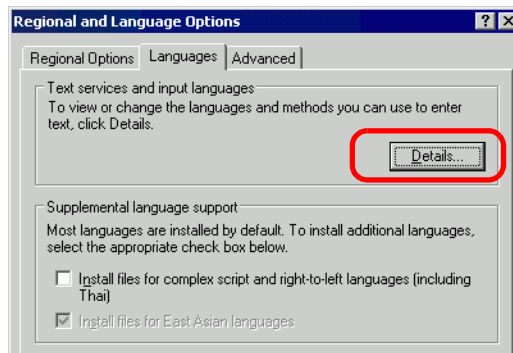

3 The [Text Services and Input Languages] dialog box appears. On the [Settings] tab, click [Add...].

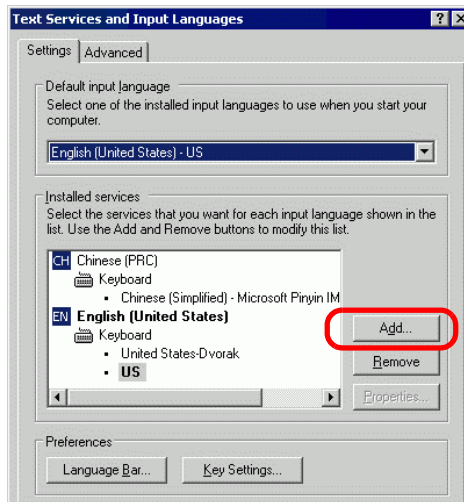

- 4 In the [Add Input language] dialog box, set the [Input language] to [Chinese (PRC)]. In [Keyboard layout/IME], select [Chinese (Simplified) - Microsoft Pinyin IME 3.0]. Click [OK].

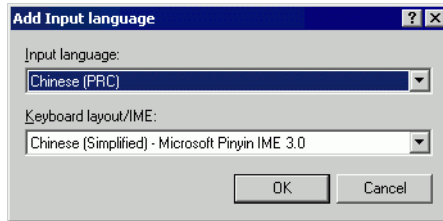

- 5 You will return to the [Text Services and Input Languages] dialog box. After confirming "Chinese (PRC)" is added to the [Installed services] area, click [Apply], then [OK] to close the dialog box.

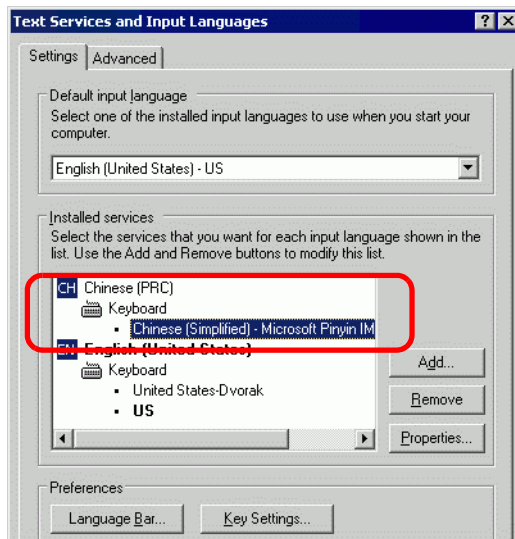

- 6 Click [OK] in the [Regional and Language Options] dialog box to complete the set up.

◆ **When using Windows®2000**

- 1 In the [Control Panel], open the [Regional Options] dialog box.
- 2 On the [General] tab, under [Language settings for the system], select [Simplified Chinese]. Click [OK].

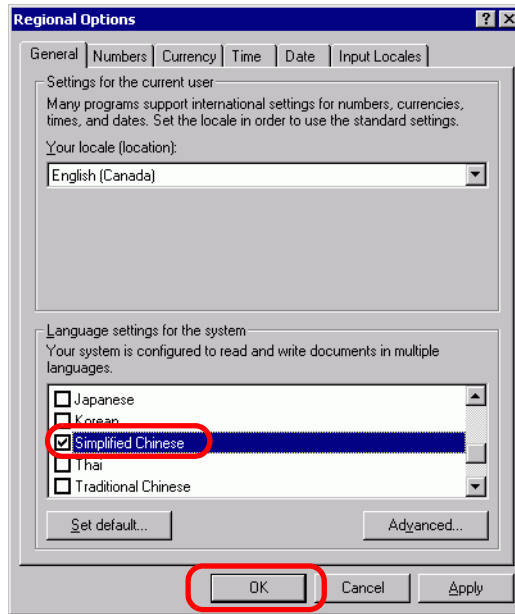

NOTE

- The dialog box below appears when adding Simplified Chinese for the first time. Insert the Windows2000 CD-ROM into the PC and click [OK].

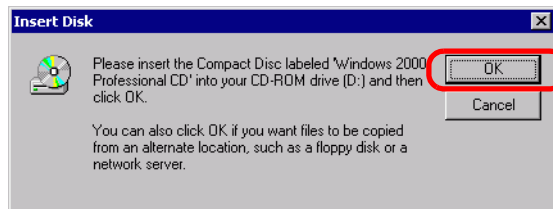

- 3 When the data has finished being copied from the CD-ROM, you must restart the PC. The dialog box below appears. Click [Yes].

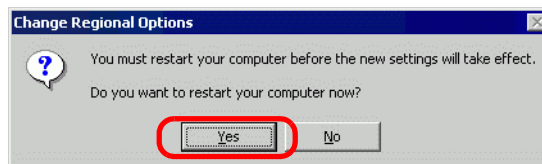

- 4 After restarting, from the [Control Panel] select [Keyboard] to open the [Keyboard Properties] dialog box.

5 From the [Input Locales] tab, in the [Installed input locales] area, click [Add...].

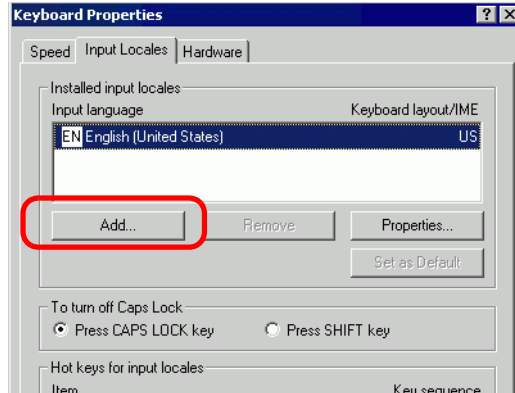

6 The [Add Input Locale] dialog box appears. Select the language to add from the [Input locale] drop-down menu and click [OK].

For example, use [Chinese (PRC)] for [Input locale] and [Chinese (Simplified) - MS-PinYin98] for [Keyboard layout/IME].

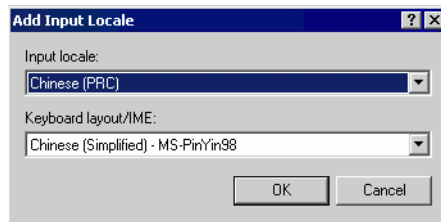

7 In the [Installed input locales], confirm "Chinese (PRC)" is added. Click [Apply] then [OK].

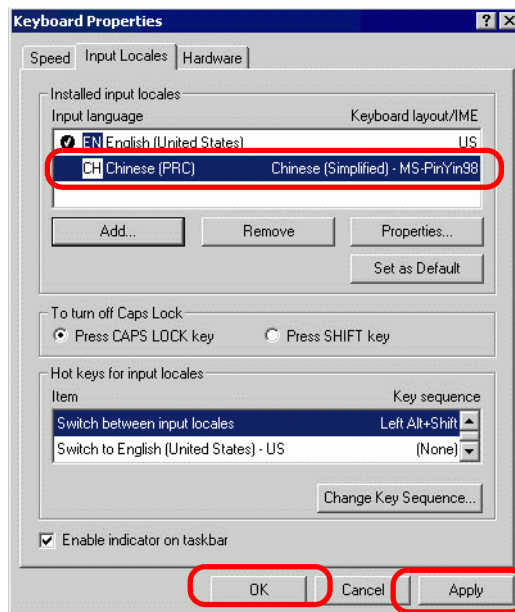

■ Adding Chinese (Simplified) Stroke Fonts to the Project

NOTE

- Please refer to the following for details about the Stroke Font.
 "6.2 Defining Stroke Font and Standard Font" (page 6-3)

1 In GP-Pro EX, in the [System Settings] window click [Font] to display the [Font] workspace.

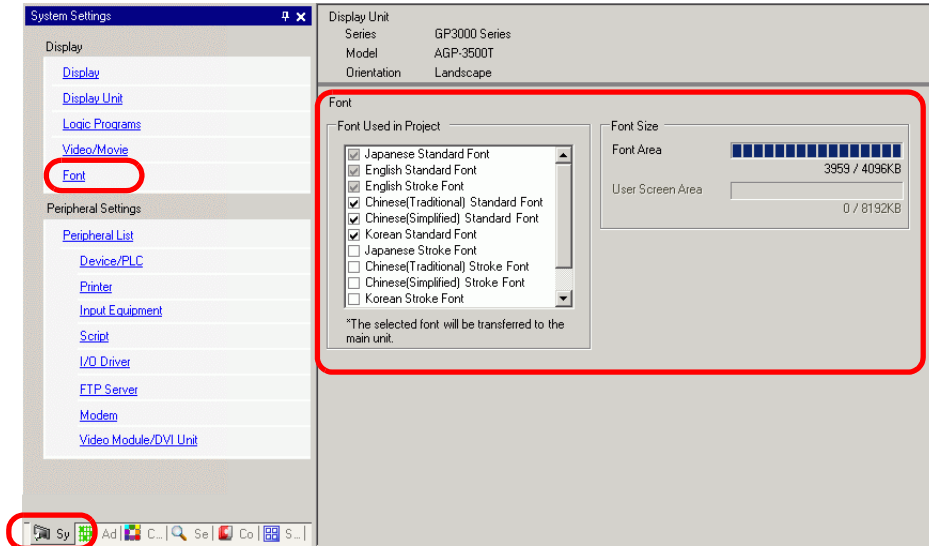

NOTE

- If the [System Settings] tab is not displayed in the workspace, on the [View (V)] menu, point to [Workspace (W)], and then click [System Settings (S)].

2 From [Font Used in Project], select the [Chinese (Simplified) Stroke Font] check box.

3 The following message appears.

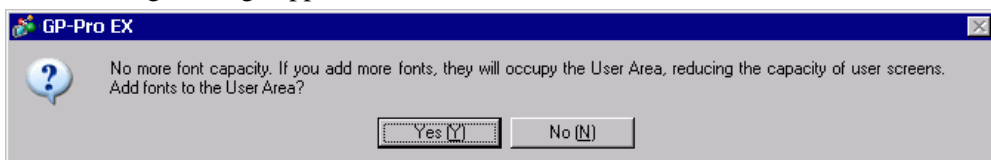

Click [Yes]. This will confirm the User Screen Area is also used for fonts.

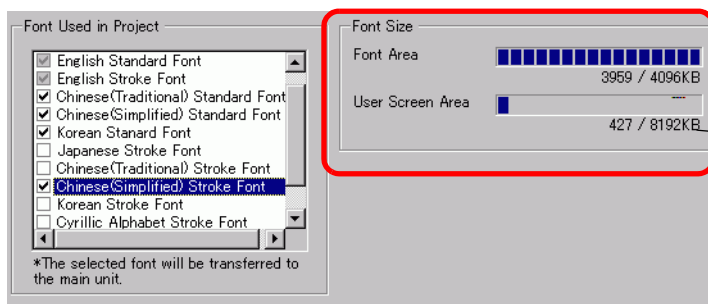

Some font data will be saved in the same area as screen data.

If you click [No], adding the font is canceled.

4 Clear check boxes for fonts you will not use. This allows more free space in the Font Area.

NOTE

- Japanese Standard Font, English Standard Font, and English Stroke Font are fixed. You cannot remove these fonts.

■ Inputting Chinese (Simplified) into a Change Screen Switch Label

- 1 In the task bar click the keyboard input system icon (for WindowsXP it's Language), and start the Chinese (PRC) keyboard input system.

For WindowsXP



For Windows2000



- 2 Launch GP-Pro EX. Double-click on the Change Screen Switch created in the process described in "11.2 Changing Screens by Touch" (page 11-4). Select the [Label] tab, set the [Font Type], [Display Language], and enter the label using pin yin.

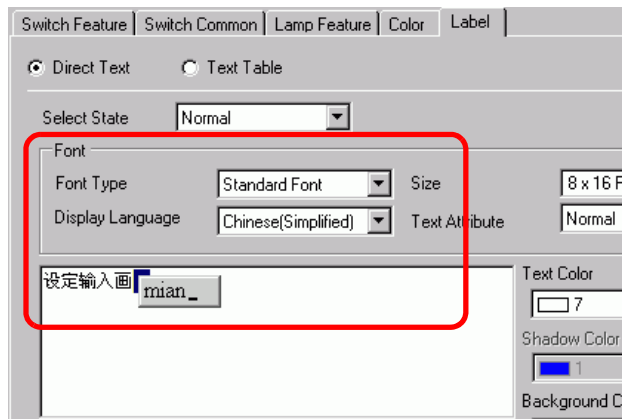

NOTE

- When you select the [Stroke Font] in [Font Type] or change the [Display Language], the following dialog box may appear. This confirms to add the font type since a switch has been set before adding the font to the system.

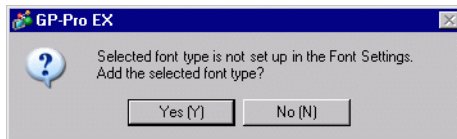

To add the font, click [Yes].

If you click [Cancel], adding the font is canceled. The entered text cannot display properly on the GP.

- 3 Click [OK] to close the [Switch/Lamp] dialog box. The Change Screen Switch's label changes to Chinese (Simplified).

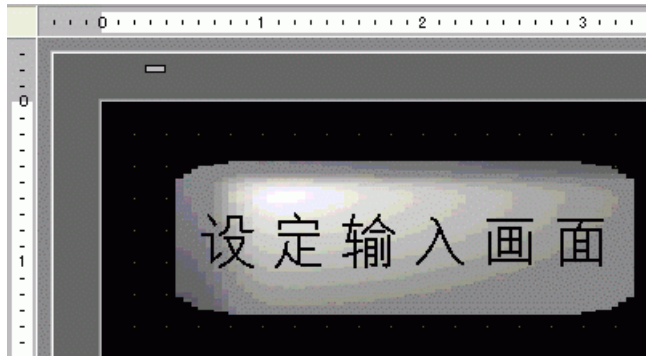

A.5 Transferring Data Between a CF Card and a USB Memory Device

A.5.1 Introduction

You can use the Special Data Display [File Manager] on the GP screen to copy or move data from the CF Card to USB memory, or from USB memory to the CF card.

This function can be used for securing available space by transferring data not immediately required in the CF Card to a USB memory device when the CF Card has limited available space, or for making a backup of the data.

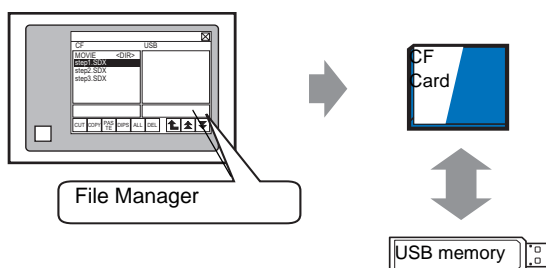

A.5.2 Setup Procedure

NOTE

- Please refer to the Settings Guide for details.
 ☞ "25.10.2 [Special Data Display] Settings Guide ■ File Manager" (page 25-83)

By using Special Data Display [File Manager], the data in the CF card inserted in the GP can be moved to the USB memory device.

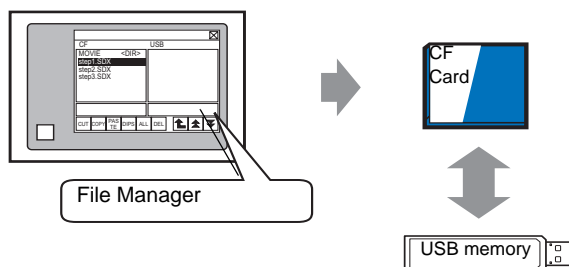

- 1 From the [Parts (P)] menu, point to [Special Data Display (P)] and select [File Manager (M)]. Place the File Manager on the screen.

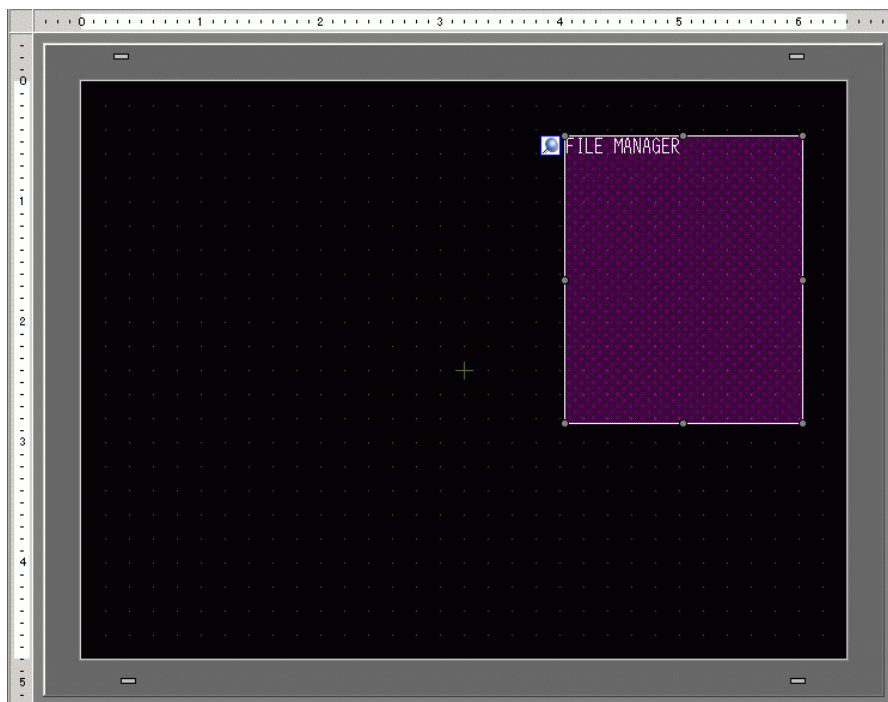

- 2 Double-click the Special Data Display [File Manager]. The following dialog box appears.

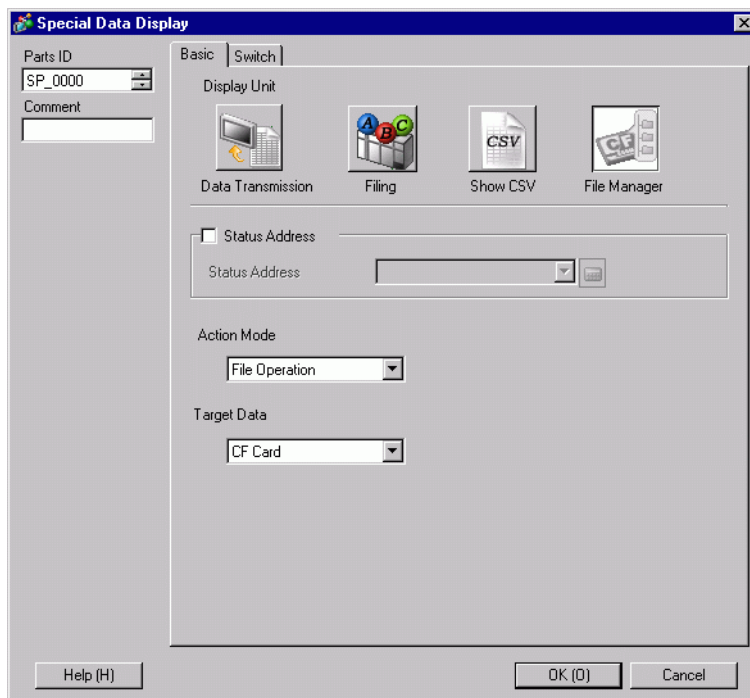

- 3 From [Action Mode], point to [File Operation], select [Target Data], and select [CF<-->USB Storage].

- 4 Click the [Switch] tab and select the [Display] check box. In [Select Shape], select the shape of the switch, specify the label and color and then click [OK].

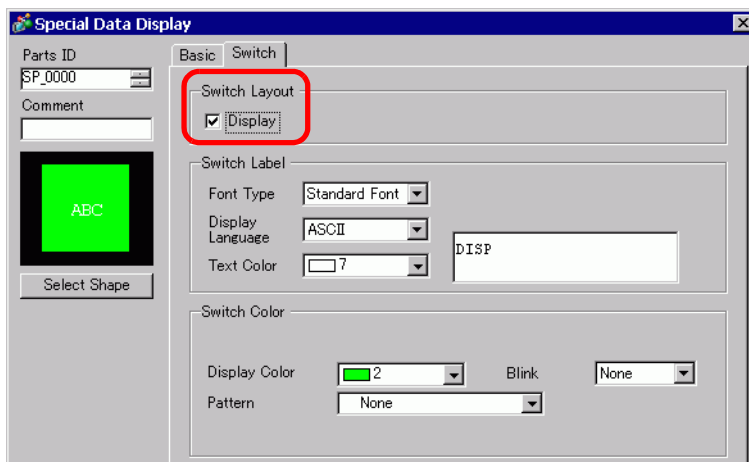

- NOTE**
- You can check the approximate available space of the CF card and the USB memory device by specifying the settings for [CF Card Available Space] and [External Memory Available Space]. To access these options, from [System Settings], point to [Display Unit] and select [Mode].

A.5.3 Operating Procedure

- 1 Insert the CF card and the USB memory into the GP.
- 2 Touch the File Manager Display Switch to call up [File Manager] on the GP screen.

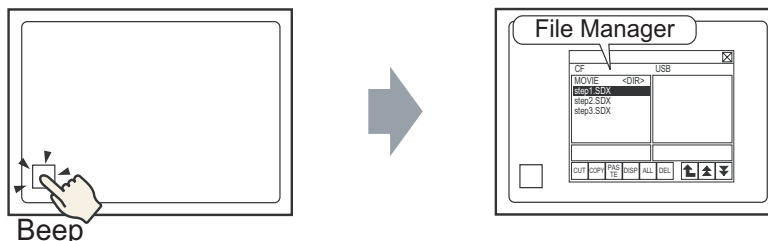

If you touch the display switch again, [File Manager] will close.

The contents of the CF card are shown on the left and the contents of the USB memory are shown on the right.

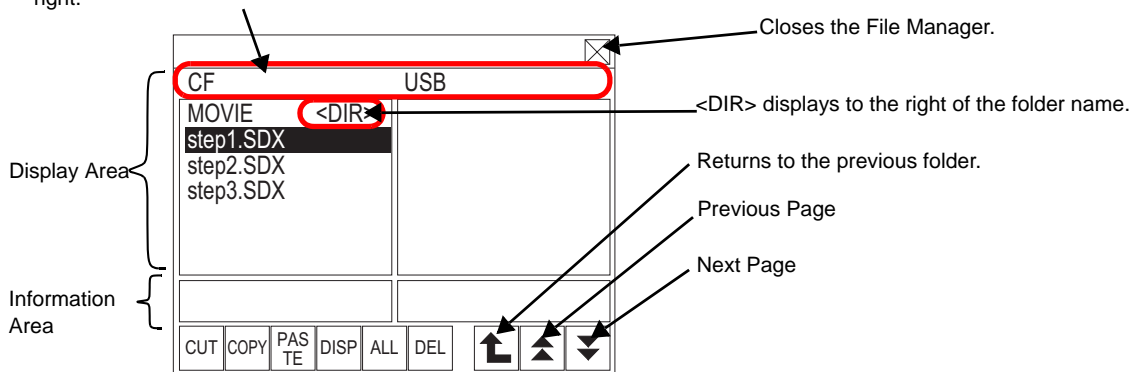

- [DEL] : Deletes the selected file or folder.
- [ALL] : Selects all the files in the displayed folder.
- [DISP] : Displays the files in the selected folder.
If you select a CSV file, it will be displayed in [CSV Display]. If you select a JPEG file, it will be displayed in [Picture Display].
- [PASTE] : Pastes the file that was cut or copied.
- [COPY] : Copies the selected file or folder.
- [CUT] : Cuts the selected file or folder.

- **Display Area**

Displays up to 19 characters of the file name. If the file name contains more than 19 characters, the file name appears as "...". (For example, "ZR12345678901234...")

Displays up to 14 characters of the folder name. If the folder name contains more than 14 characters, the folder name appears as "...". (For example, "ABCDEFGHJKLMN...<DIR>").

The full-path name can contain up to 100 characters (folder name + file name).

- **Information Area**

When you select a folder, the folder creation date displays. Selecting a file displays the creation date and size of the file.

NOTE

- Do not connect more than one USB storage device. If you do so, the USB devices may not be recognized properly.
- If a CF Card or USB memory device is not inserted, File Manager will still be displayed, however nothing appears in the Display Area. Immediately after a CF Card or USB memory is inserted in the GP, first the root folder is displayed.

- 3 Select a file in "CF". To open a file in a child folder, touch the folder name then touch [DISP]. This displays the files in the folder.

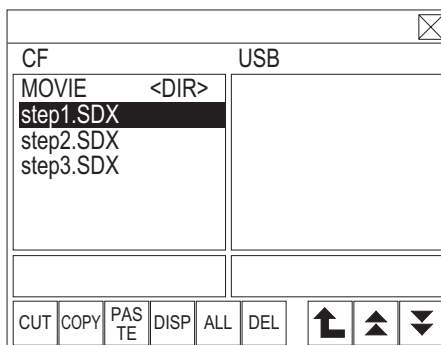

NOTE

- Touch the selected file again to clear the selection.
- Multiple files can be selected in the displayed area. If you switch the page, the selection is cleared. Up to seven folders or files can be displayed on one page.
- The files is displayed in the order in which they were created. It is not possible to sort the files by file name or time stamp.

- 4 Once the files are selected, touch [CUT]. The [USB] destination is highlighted.
- 5 Touch [PASTE]. The message, "If a file already exists, it will be overwritten" is displayed. Touch [OK] to paste the file to [USB].

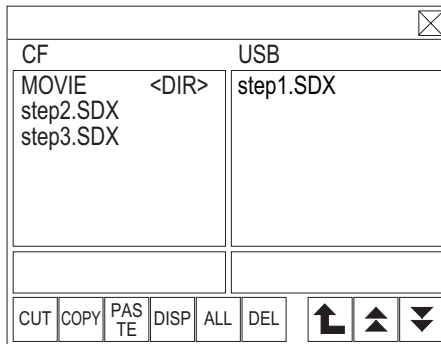

The file is transferred from the CF Card to the USB memory device.

IMPORTANT

- While accessing a CF Card or a USB memory device, do not reset the display unit or remove the CF Card or USB memory device.

NOTE

- You cannot change the size of the File Manager Window.
- A file cannot be copied or transferred in the following cases: CF Card→CF Card, and USB device→USB device.
- If you switch pages while [CUT] or [COPY] is selected, the selection is not cleared.
- The CSV file open in the [CSV Display] cannot be cut or deleted.
- If you switch the screen while a file is being copied, cut, or deleted, the process continues while the screen is switched.
- An error occurs if you transfer a file to a folder that is not displayed correctly in File Manager or if you try to perform a file operation in that folder.

Moving a File Manager

The screen position of Special Data Display [File Manager] can be changed.

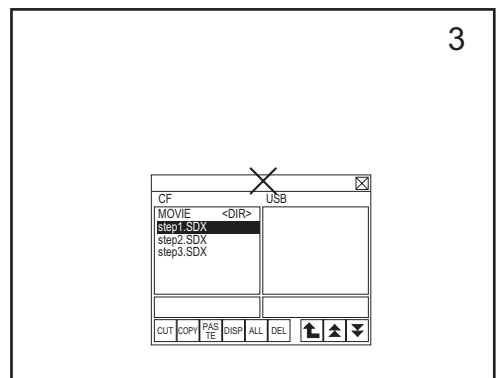
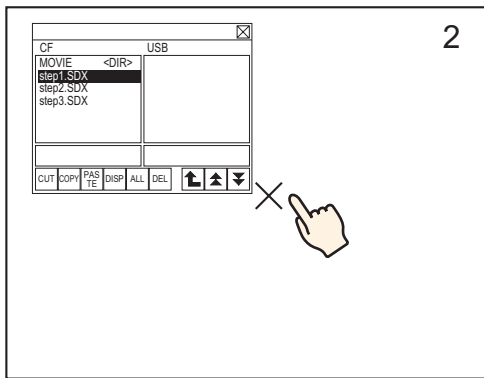
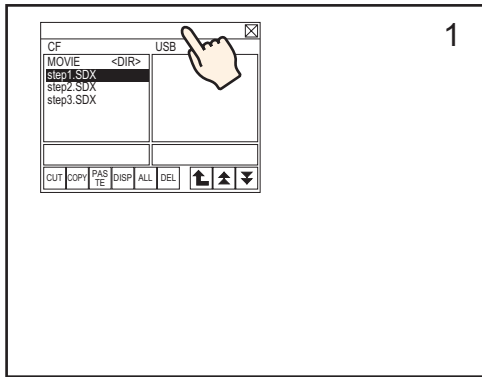

- 1 Touch the top of the [File Manager] Display.
- 2 Touch the desired position on the screen where you want the display to move.
- 3 The [File Manager] moves to the specified location.

NOTE

- If the [File Manager] Display runs off the screen at a specified position, the coordinates adjust so that the entire window displays.

A.6 System Variables

The predefined variables in GP-Pro EX are called system variables.

System variables are either logic system variables (#L system variables) or HMI system variables (#H system variables). System variables indicate the state of the GP and affect operation. Similar to symbol variables, system variables have variable types (integer/bit) and operate in the same way as symbol variables.

IMPORTANT

- You cannot add or delete system variables.
 - The names of system variables is the same regardless of [Variable Format] and [Address Format].
 - #L system variables are retentive variables. Even if you turn off the GP, their current values are saved. #H system variables are volatile variables. You can confirm if a variable is retentive or volatile in the Properties window's [Detail Settings].
 - #H system variables are not synchronized with logic programs. Therefore, correct values may not be designated at a certain timing.
-

A.6.1 Logic System Variables (#L System Variables)

For models that support logic, you can use the Logic System Variables when in the [System Settings] workspace, [Logic Programs] screen, the [Logic Program] option is enabled.

For models that support logic programs, see the following.

☞ "1.3 Supported Features" (page 1-5)

■ Bit Logic System Variables

Variable Name	Description	Read	Write
Ladder Reference Flag			
#L_RunMonitorA	ON while in RUN mode	O	X
#L_AlwaysON	Always ON	O	X
Calculation Flag			
#L_CalcZero	Zero flag	O	X
#L_CalcCarry	Carry flag	O	X
System Settings			
#L_ScanModeSW	Logic Mode Setting	O	X
#L_AutoRunSW	Mode setting at startup	O	X
#L_InOutSW	Enabling external input and output enable setting	O	X
#L_FaultStopSW	Continue on error switch setting	O	X
#L_SyncRunSW	Synchronous Communication with External Devices/PLCs	O	X
Operation Information			
#L_UnlatchClear	Reset to zero for volatile areas	O	O
#L_LatchClear	Reset to zero for retentive areas	O	O
Time			
#L_Clock100ms	100 millisecond clock pulse	O	X
#L_Clock1sec	1 second clock pulse	O	X
#L_Clock1min	1 minute clock pulse	O	X
Address Refresh			
#L_RefreshEnable	Address Refresh Enable Flag	O	X
Error information			
#L_BatteryErr	Battery malfunction	O	X
#L_Error	Logic error	O	X
#L_StopPending	Logic stop wait flag	O	X
#L_Fault	Error handler stop flag	O	O
#L_IOFault	I/O error flag	O	X

◆ #L_RunMonitorA (ON while in RUN mode)

ON when the logic program is running, and OFF when the logic program is not running. Because this is a read-only area, writing is not possible. If you write in this area, the operation may fail.

◆ #L_AlwaysON (Always ON)

On at the beginning of a logic scan, regardless of whether or not the logic program is used. Because this is a read-only area, if OFF is written, in the program below the #L_AlwaysON bit is turned OFF.

ON is rewritten at the beginning of the next scan. Do not perform a write operation for #L_AlwaysON.

◆ #L_CalcZero (Zero flag)

#L_CalcZero turns ON only when the operation result is zero (0).

Every time an operation is executed, the contents of #L_CalcZero are rewritten.

After the execution of an operation, #L_CalcZero rewrites OFF or ON. Because this is a read-only area, writing is not possible.

◆ #L_CalcCarry (Carry flag)

Depending on the result after the execution of an operation, #L_CalcCarry turns ON only when a carry occurs.

Every time an operation is executed, the contents of #L_CalcCarry are rewritten.

After the execution of an operation, #L_CalcCarry rewrites OFF or ON. Because this is a read-only area, writing is not possible.

◆ #L_ScanModeSW (Logic Mode Setting)

You can check the operation mode of the logic program currently being executed.

When #L_ScanModeSW is ON, operation is in CPU Scan Percentage mode. When

#L_ScanModeSW is OFF, operation is in Fixed Scan Time mode. Because this is a read-only area, writing is not possible.

◆ #L_AutoRunSW (Mode setting at startup)

When the action setting at power ON is set to RUN, #L_AutoRunSW turns ON.

When the action setting at power ON is set to STOP, #L_AutoRunSW turns OFF.

Because this is a read-only area, writing is not possible.

◆ **#L_InOutSW (Setting of external input and output enable)**

If the external input and output settings are enabled in the action settings at power ON, #L_InOutSW turns ON.

If the external input and output settings are disabled in the action settings at power ON, #L_InOutSW turns OFF.

Because this is a read-only area, writing is not possible.

◆ **#L_FaultStopSW (Continue on error switch setting)**

When [Minor Errors] is set to STOP, operation stops when a minor error occurs and #L_FaultStopSW turns ON.

When the [Minor Errors] is set to RUN, operation continues when a minor error occurs and #L_FaultStopSW turns OFF.

Because this is a read-only area, writing is not possible.

◆ **#L_SyncRunSW (Synchronous Communication with External Devices/PLCs)**

If communication with external devices/PLCs is synchronized in the action settings when powering ON, #L_SyncRunSW turns ON.

If communication with external devices/PLCs is not synchronized in the action settings when powering ON, #L_SyncRunSW turns OFF.

Because this is a read-only area, writing is not possible.

◆ **#L_UnLatchClear (Reset to zero volatile areas)**

By turning ON #L_UnLatchClear, zero clear of the clear area is requested. (An up edge is detected and the area is cleared to zero.)

This variable operates only when the logic program is in STOP.

The setting value and time base of the timer and the setting value of the counter cannot be cleared to zero. The system variables and addresses of the connection devices cannot be cleared to zero.

Reading and writing is possible in this area.

◆ **#L_LatchClear (Reset to zero retentive areas)**

By turning ON #L_LatchClear, zero clear of a retentive area is requested. (A rising edge is detected and the area is cleared to zero.)

This bit operates only when the logic program is in STOP.

The setting value and time base of the timer and the setting value of the counter cannot be cleared to zero. The system variables and addresses of the connection devices cannot be cleared to zero.

Reading and writing is possible in this area.

◆ **#L_Clock100ms (100 millisecond clock pulse)**

The variable turns ON and OFF repeatedly with a frequency of 50 milliseconds OFF time and 50 milliseconds ON time.

Because this is a read-only area, writing is not possible.

When the Scan Time is longer than the clock pulse, ON and OFF are not repeated. Confirm and set the Scan Time.

◆ **#L_Clock1sec (1 second clock pulse)**

The variable turns ON and OFF repeatedly with a frequency of 500 milliseconds OFF time and 500 milliseconds ON time.

Because this is a read-only area, writing is not possible.

When the Scan Time is longer than the clock pulse, ON and OFF are not repeated. Confirm and set the Scan Time.

◆ **#L_Clock1min (1 minute clock pulse)**

The variable turns ON and OFF repeatedly, with a frequency of 30 seconds OFF time and 30 seconds ON time.

Because this is a read-only area, writing is not possible.

When the Scan Time is longer than the clock pulse, ON and OFF are not repeated. Confirm and set the Scan Time.

◆ **#L_RefreshEnable**

When the address refresh is enabled, the bit is turned ON.

Enable Condition: (1) First PLC communication scan is complete. (When more than one PLC is connected, all first communication scans are complete.)
(2) PLC communication is normal.

Disable Condition: (1) First PLC communication scan is not complete. (When more than one PLC is connected, all first communication scans are not complete.)
(2) PLC communication failure occurred. (When you connect more than one, more than one of PLC communication failure has occurred.)

◆ **#L_BatteryErr (Battery error)**

Turns on when battery malfunction information is detected on the GP.

If this bit turns ON, the #L_BatteryErr bit does not turn OFF until the GP is reset or the power turns OFF.

Because this is a read-only area, writing is not possible.

◆ **#L_Error (Logic error)**

Turns ON if an error occurs in the logic operation.

If this bit turns ON, the #L_Error bit does not turn OFF until the GP display unit is reset or the power turns OFF.

Because this is a read-only area, writing is not possible.

◆ **#L_StopPending (Logic stop wait flag)**

The #L_StopPending bit remains ON Until #L_StopScans reaches 0.

Until #L_StopScans is zero, the #L_StopPending bit remains ON for the duration of the scans until the logic stops.

Because this is a read-only area, writing is not possible.

◆ #L_Fault (Error handler stop flag)

This flag is referenced at the end of the "error handler" subroutine to determine whether to stop or continue the execution of the logic program.

The execution of the logic program on the GP will stop at the end of ERRH routine if the #L_Fault bit is ON.

Reading and writing is possible in this area.

#L_Fault is not used without an "error handler" subroutine.

◆ #L_IOFault (I/O error flag)

#L_IOFault turns ON if an I/O error occurs on the I/O driver.

The flag remains until another error occurs or until the GP is reset.

■ Integer Logic System Variables

Variable Name	Description	Read	Write
Scan Time			
#L_ScanTime	The time from the start of step 0 of the current scan to the start of step 0 of the next scan	O	X
#L_AvgScanTime	The average of 64 #L_ScanTime cycles	O	X
#L_MinScanTime	The minimum scan time for #L_ScanTime	O	X
#L_MaxScanTime	The maximum scan time for #L_ScanTime	O	X
#L_ScanCount	Number of scans	O	X
#L_LogicTime	The time from the start of step 0 to the END instruction	O	X
#L_AvgLogicTime	The average of 64 #L_LogicTime cycles	O	X
#L_MinLogicTime	The minimum logic time for #L_LogicTime	O	X
#L_MaxLogicTime	The maximum logic time for #L_LogicTime	O	X
Status			
#L_Status	Logic status information	O	X
#L_Platform	Code number of the GP platform	O	X
#L_Version	Logic firmware version	O	X
#L_EditCount	Number of online edits	O	X
#L_ForceCount	Cumulative count of variables that are forcedly changed	O	X
#L_IOInfo	I/O driver information	O	X
#L_LogicInfo	Logic Information	O	X
#L_IOMasterDrv* ¹	Master I/O Driver Extended Information	Depends on the I/O Driver	Depends on the I/O Driver
System Settings			
#L_ConstantScan	Logic startup frequency	O	X
#L_PercentScan	Logic operation rate	O	X
#L_WatchdogTime	Logic WDT value	O	X
#L_AddressRefreshTime	Connection device address refresh time	O	X
Time			
#L_Time	Time information	O	X

Continued

Variable Name	Description	Read	Write
Operation Information			
#L_Command	Changes the logic operation mode	O	O
#L_LogicMonitor	The logic monitor startup switch	O	O
#L_LogicMonStep	Indicates the steps for displaying the logic monitor	O	O
I/O Status			
#L_IOStatus	Status of the built-in I/O driver	O	X
Error information			
#L_CalcErrCode	Storage area for calculation error codes	O	X
#L_FaultStep	Storage area for the step Number of the calculation error	O	X
#L_FaultLogicScreen	Storage area for the logic screen number of the calculation error	O	X
Logic Stop			
#L_StopScans	Number of logic stop scans	O	O
Retentive Variable Backup			
#L_BackupCmd	Backup Command	O	O
LT Common^{*2*3}			
#L_ExIOFirmVer	Extended I/O port firmware version	O	X
#L_ExIOSpCtrl	Special I/O control	O	O
#L_ExIOSpOut	Special output	O	X
#L_ExIOSpParmChg	Change Special I/O parameter	O	O
#L_ExIOSpParmErr	Special I/O parameter error	O	X
#L_ExIOAccelPIsTbl	Acceleration/deceleration pulse table	O	O
#L_ExIOCntInCtrl	Counter input control	O	O
#L_ExIOCntInExtCtrl	Counter input external control	O	O
#L_PWM*_WHZ	Ch* output frequency	O	O
#L_PWM*_DTY	Ch* ON duty value	O	O
#L_PLS*_LHZ	Ch* output frequency	O	O
#L_PLS*_NUM	Ch* output pulse	O	O
#L_PLS*_SHZ	Ch* initial output frequency	O	O
#L_PLS*_ACC	Ch* acceleration/deceleration time	O	O
#L_PLS*_CPC	Ch* pulse output current value	O	X
#L_HSC*_MOD	Ch* count system	O	O
#L_HSC*_PLV	Ch* preload value	O	O

Continued

Variable Name	Description	Read	Write
#L_HSC*_PSV	Ch* pre-strobe value	O	X
#L_HSC*_ONP	Ch* ON preset value	O	O
#L_HSC*_OFF	Ch* OFF preset value	O	O
#L_HSC*_HCV	Ch* counter current value	O	X

1 [] = 0 to 255.

*2 For details, see "30.5 Controlling External I/O in LT" (page 30-25).

3 [] = Channel Number (1 to 4).

◆ **#L_ScanTime (time from the start of step 0 of the current scan to the start of step 0 of the next scan)**

Stores the scan time of the previous scan just before the execution of the next scan.

Scan time is the time required for I/O reading, execution of the logic program, I/O output, and display processing.

The unit is 0.1 ms.

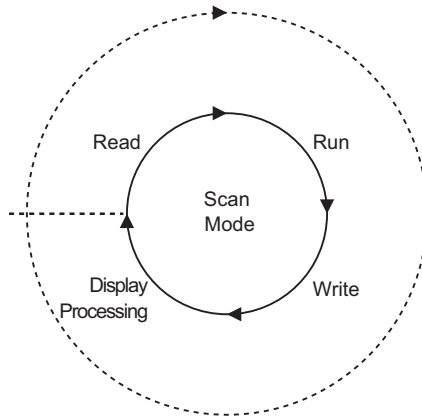

◆ **#L_AvgScanTime (Average of 64 #L_ScanTime cycles)**

Stores the average scan time.

Average scan time is the average time required for I/O reading, execution of the logic program, I/O writing, and display processing in one scan.

The variable is updated with each completion of 64 scan cycles.

The unit is 0.1 ms.

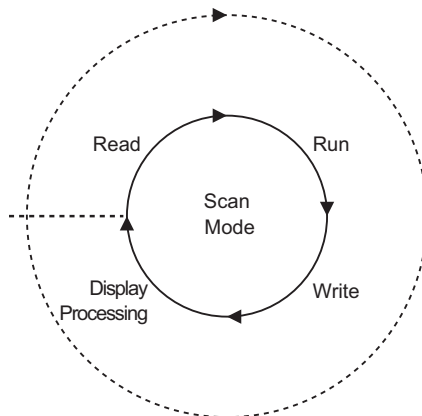

◆ **#L_MinScanTime (Minimum scan time of #L_ScanTime)**

Stores the minimum scan time of the logic program.

When #L_ScanTime is updated, the minimum scan check is performed and the variable is updated with every scan.

The unit is 0.1 ms.

◆ **#L_MaxScanTime (Maximum scan time of #L_ScanTime)**

Stores the maximum scan time of the logic program.

When #L_ScanTime is updated, the maximum scan check is performed and the variable is updated with every scan.

The unit is 0.1 ms.

◆ **#L_ScanCount (Number of scans)**

Upon completion of each logic program scan, the counter increments the variable.

The value in #L_ScanCount ranges from 0 to 16#FFFFFFFF. When the maximum value (16#FFFFFFFF) is exceeded, the variable is incremented again from 0.

You can confirm whether the logic program is being executed by checking #L_ScanCount.

◆ **#L_LogicTime (Time from the start of step 0 to the END instruction)**

Stores the logic time of the previous scan execution.

Logic time is the time required for I/O reading, execution of the logic program, and I/O writing in one scan. The display processing time is not included. The unit is 0.1 ms.

◆ **#L_AvgLogicTime (Average of 64 #L_ScanTime cycles)**

Stores the average logic time.

Average logic time is the average time required for I/O reading, execution of the logic program, and I/O writing in one scan.

The variable is updated with each completion of 64 scan cycles. The unit is 0.1 ms.

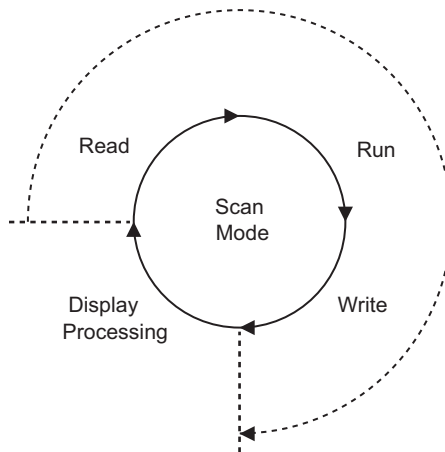

◆ **#L_MinLogicTime (Minimum logic time of #L_LogicTime)**

Stores the minimum logic time of the logic program.

When updating #L_LogicTime, the minimum logic time is checked and the variable is updated with every scan.

The unit is 0.1 ms.

◆ **#L_MaxLogicTime (Maximum logic time of #L_LogicTime)**

Stores the maximum logic time of the logic program.

When updating #L_LogicTime, the maximum logic time is checked and the variable is updated with every scan.

The unit is 0.1 ms.

◆ **#L_Status (Logic status information)**

Displays the state of the GP. Bytes and bits are defined as follows:

Byte 0: Displays the current error state on the GP.

Byte 1: Displays the error state history. This byte resets to 0 only when the GP is reset.

Byte 2: Displays the current operation state.

Byte 3: Reserved area.

Byte 3 Reserved	Byte 2 Current state	Byte 1 Error state history	Byte 0 Current error state
--------------------	-------------------------	-------------------------------	-------------------------------

Byte 0 (latch)

Total Error	Scan Error	Reserved	Read Error	Over flow	I/O error	Minor Error	Major Error
-------------	------------	----------	------------	-----------	-----------	-------------	-------------

Bit

7	6	5	4	3	2	1	0
---	---	---	---	---	---	---	---

Byte 1 (latch)

Total Error	Scan Error	Reserved	Read Error	Over flow	I/O error	Minor Error	Major Error
-------------	------------	----------	------------	-----------	-----------	-------------	-------------

Bit

15	14	13	12	11	10	9	8
----	----	----	----	----	----	---	---

Byte 2 (latch)

Reserved	Awaiting Communication	Standby	Stopped	Pause	Force change Enable/	I/O available	In RUN mode
----------	------------------------	---------	---------	-------	----------------------	---------------	-------------

Bit

23	22	21	20	19	18	17	16
----	----	----	----	----	----	----	----

Byte 3 (latch)

Reserved	Reserved	Reserved	Reserved	Reserved	Reserved	Reserved	Reserved
----------	----------	----------	----------	----------	----------	----------	----------

Bit

31	30	29	28	27	26	25	24
----	----	----	----	----	----	----	----

◆ **#L_Platform (GP platform code number)**

Stores the GP platform code number.

H	Stores the GP platform code number.
L	

Format	Code
AGP-3302B	0x00020404
AGP-3301	0x00020504
AGP-3300	0x00020514
AGP-3400	0x00020614
AGP-3500	0x00020714
AGP-3600	0x00020814
AGP-3450	0x00020634
AGP-3550	0x00020734
AGP-3650	0x00020834
AGP-3750	0x00020934
AGP-3510	0x00020A14
AGP-3560	0x00020A34
LT-3201A	0x00030204
LT-3301	0x00030504
LT-3300	0x00030514

◆ **#L_Version (Logic firmware version)**

Stores the logic firmware version.

◆ **#L_EditCount (Number of online edits)**

Stores the number of online edits. (This variable cannot be executed while writing in RUN.)

◆ **#L_ForceCount (Cumulative count of variables that are forcedly changed)**

Stores cumulative count of variables that are forcedly changed

◆ **#L_IOInfo (I/O driver information)**

Stores information on the I/O driver.

◆ **#L_LogicInfo (Logic Information)**

Reserved by the System.

◆ **#L_IOMasterDrv* (Master I/O Driver Extended Information)**

[*] = 0 to 255.

Stores Master I/O Driver Extended Information.

☞ "30.7.4 Using I/O Driver Instructions" (page 30-158)

◆ **#L_ConstantScan (Logic startup frequency)**

Sets the scan time in units of 10 ms in Fixed Scan Time mode.

When logic time is constant, the display processing time can be extended by increasing the value of #L_ConstantScan. By decreasing the value, the display processing time can be reduced. This is because most of the processing time is used by logic functions.

Set this as a default setting.

NOTE

☞ "29.13.3 Adjusting Logic Scan Time ◆ Fixed Scan" (page 29-121)

◆ **#L_PercentScan (Logic operation rate)**

Sets the usage rate of the logic function compared to the total logic processing time in CPU Scan Percentage mode. Specify this variable in units of 10 ms.

Set this as a default setting.

NOTE

☞ "29.13.3 Adjusting Logic Scan Time ◆ CPU Percentage Scan" (page 29-122)

◆ **#L_WatchdogTime (WDT value of the logic)**

Sets the WDT value (watch dog timer) in ms.

When #L_ScanTime exceeds this value, a major error occurs.

Set this as a default setting.

◆ **#L_AddressRefreshTime (Connection device address refresh time)**

Stores the address refresh time for the connection device addresses used in the logic program. The unit is 100 microseconds.

NOTE

☞ "29.13.3 Adjusting Logic Scan Time ■ Address Refresh" (page 29-124)

◆ **#L_Time (Time information)**

Indicates the "time" set in the logic in 4-digit BCD.

The time is stored in the following state:

For example, 11:19 PM

	Hours (ten's column)	Hours (one's column)	Minutes (ten's column)	Minutes (one's column)
Value	2	3	1	9

◆ **#L_Command (Changes the logic operation mode)**

This is an integer variable used as a logic control command.

After the logic acknowledges #L_Command, bits other than bit 7 are reset to 0. If multiple bits are ON, the least significant bit takes priority.

Byte 3 Reserved	Byte 2 Reserved	Byte 1 Reserved	Byte 0
--------------------	--------------------	--------------------	--------

Byte 0

I/O Enable/ disable	Reserved	Pause	Continue	1 scan	Reset	Run	Stop
---------------------------	----------	-------	----------	--------	-------	-----	------

Bit 7 6 5 4 3 2 1 0

◆ **#L_LogicMonitor (Startup switch of the logic monitor)**

Starts up and operates the logic program monitor function on the GP.

The following shows each operation.

Byte 3	Byte 2	Byte 1	Byte 0
--------	--------	--------	--------

Byte 0

Reserved	Reserved	Reserved	Reserved	Reserved	Reserved	Logic monitor Trigger: 1	Address Monitor Trigger: 1
----------	----------	----------	----------	----------	----------	-----------------------------	----------------------------------

Bit 7 6 5 4 3 2 1 0

Byte 1

Reserved	Reserved	Reserved	Reserved	Reserved	Reserved	Reserved	Reserved
----------	----------	----------	----------	----------	----------	----------	----------

Bit 15 14 13 12 11 10 9 8

Byte 2

Reserved	Reserved	Reserved	Reserved	Reserved	Reserved	Reserved	Reserved
----------	----------	----------	----------	----------	----------	----------	----------

Bit 23 22 21 20 19 18 17 16

Byte 3

Starting: 1 Stopped: 0	Reserved	Reserved	Reserved	Reserved	Reserved	Reserved	Reserved
---------------------------	----------	----------	----------	----------	----------	----------	----------

Bit 31 30 29 28 27 26 25 24

◆ **#L_LogicMonStep (Indicates the steps for displaying the logic monitor)**

Stores the starting rung number to be displayed when the logic monitor is running.

If the logic monitor is not running, write the rung number in #L_LogicMonStep to start up the logic monitor with the specified rung number as the first rung when the logic monitor trigger bit (bit 0 of #L_LogicMonitor) turns OFF ON.

This variable is used when the logic monitor function is enabled.

◆ #L_IOStatus (Status of the built-in I/O driver)

Stores the error codes for the built-in I/O driver.

The error codes can be confirmed by checking the error messages displayed in #L_IOStatus and on the screen.

The detailed error code classifications are defined as follows:

Error Code	Description
001-049	Project data error
050-099	Hardware error
100-199	Application error
200-254	Internal error

The stored error codes are as shown below.

H		Model Number Storage Area							
L	Major Fault	0	0	0	0	0	Settings	Verification	Error Code Storage Area

Model Number Storage Area

Model number of the unit where the error occurred is stored. This will be reserved bits depending on the I/O driver used.

Verification

When the I/O attribute of the specified unit is the same as that of the actually connected unit, but the points differ, "1" is set. This will be reserved bits depending on the I/O driver used.

Settings

When the I/O attribute of the specified unit is different from that of the actually connected unit, "1" is set. This will be reserved bits depending on the I/O driver used.

Major Fault

When a failure that stops the logic such as an auxiliary board ID conflict or project data failure is found, "1" is set.

Error Message

Error Code Classification	Description
RGEA***	Built-in I/O driver

*** indicates the error codes for each driver (0 - 255).

For details, see the error information of each I/O Driver.

◆ #L_CalcErrCode

The calculation error state can be identified in #L_CalcErrCode. The area is cleared to 0 when reset.

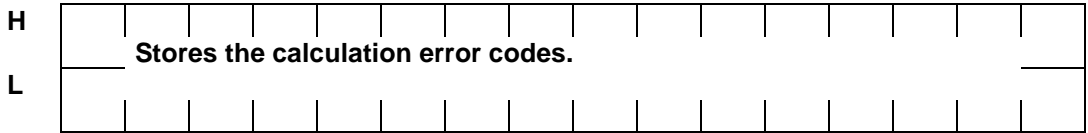

Error Code List

Error Code	Description	
0000	- No error.	
0001	Minor error (continue) An overflow occurs when converting numbers, from real integer, or a 64-bit real 32-bit real.	
0002	Major error (stop)	A reference exceeded the array size.
0003		A reference exceeded the range of an integer.
0004		Stack overflow.
0005		An invalid instruction code is used.
0006		An error occurred during error handler processing.
0007		The scan time exceeded the WDT.
0008		Major error (stop)
0009	Software error	
0010	An invalid operand is used.	
0011	- Reserved	
0012	Minor error (continue)	BCD/BIN conversion error
0013		ENCO/DECO conversion error
0014	- Reserved	
0015	Minor error (continue)	The SRAM data (user program) is read from a destroyed FROM.
0016		The shift bit value exceeded the range.
0100	Major error (stop)	Major error occurred on I/O driver instruction
0105	Minor error (continue)	Minor error occurred on I/O driver instruction
6701	Continue on error	<ul style="list-style-type: none"> The CJ and CALL instructions have no jump destination. The index has been modified so that the address is outside of the P0 to P4095 range where a label is not defined. P63 was executed in a CALL instruction. P63 cannot be used in a CALL instruction that branches to END.

Continued

Error Code	Description
6702	The CALL instruction has a nesting level of 6 or higher.
6703	The interrupt has a nesting level of 3 or higher.
6704	The FOR and NEXT instructions have a nesting level of 6 or higher.
6705	The application instruction operand is outside the target device.
6706	The device Number and data value of the application instruction operand have exceeded the range.
6707	The final register was accessed without specifying the parameter settings.
6708	FROM/TO instruction error
6709	Other (invalid branch)
6710	Parameter incompatibility
6730	The sampling time (Ts) is out of range ($T_s \leq 0$).
6731	
6732	The input filter constant (α) is out of range ($\alpha < 0$ or $100 \leq \alpha$).
6733	The proportion gain (Kp) is out of range ($K_p < 0$).
6734	The integral calculus time (Ti) is out of range ($T_i < 0$).
6735	The differential gain (Kd) is out of range ($K_d < 0$ or $201 \leq K_d$).
6736	The differential calculus time (Td) is out of range ($T_d < 0$).
6740	Sampling time (Ts) \leq sampling frequency
6742	The change in measurement value is out of range ($\Delta PV < -32768$ or $32767 < \Delta PV$).
6743	The deviation is out of range ($EV < -32768$ or $32767 < EV$).
6744	The integral calculated value is out of range (other than -32768 to 32767).
6745	The differential value is out of range because the differential gain (Kd) is out of range.
6746	The differential calculated value is out of range (other than -32768 to 32767).
6747	The PID calculation result is out of range (-32768 to 32767).
6748	The PID output upper limit setting value $<$ Output lower limit setting value
6749	PID input/output change alarm settings error.
6750	Step response method. Auto-tuning result failure
6751	Step response method. Incompatibility of auto-tuning direction
6752	Step response method. Auto-tuning failure

Continued

Error Code	Description
6753	Limit cycle method. Incompatibility of auto-tuning output settings values [ULV (upper limit) <= LLV (lower limit)]
6754	Limit cycle method. Incompatibility of auto-tuning PV threshold (hysteresis) settings values (SHpv < 0)
6755	Limit cycle method. Auto-tuning transition state error.(The data in the device managing the transition state was not successfully rewritten.)
6756	Limit cycle method. Result error caused by exceeding the auto-tuning measurement time. ($t > t$, $t < t$, $t < 0$)
6757	Limit cycle method. The proportion gain of the auto-tuning result is out of range. (Kp = other than 0 to 32767)
6758	Limit cycle method. The integral calculus time of the auto-tuning result is out of range. (Ti = other than 0 to 32767)
6759	Limit cycle method. The differential calculus time of the auto-tuning result is out of range. (Td = other than 0 to 32767)
6760	The sum of ABS data from the server is inconsistent.
6762	The port specified by the inverter communication instruction is already being used.
6765	Application instruction usage time error
6770	Writing to the FLASH memory board failed
6771	The FLASH memory board is disconnected.
6772	The write error that occurs when writing to the FLASH memory board is prohibited.

◆ #L_FaultStep

Stores the program step Number when abnormal processing occurs.

◆ #L_FaultLogicScreen

Stores the logic screen Number when abnormal processing occurs.

INIT :1

MAIN :2

ERRH :3

SUB-01: 32 to SUB-32:63

◆ #L_StopScans

Enter a numeric value to execute scanning for the specified number of times. The logic scan continues until the setting reaches 0. Meanwhile, the #L_StopPending bit is ON. When this bit turns OFF, the logic stops.

◆ #L_BackupCmd

When you backup the data of the variables specified to be kept, it triggers backup and restore.

Bit 0: When backup is executing, the lower 16 bits are turned OFF automatically.

Bit 1: When restore is executing, the lower 16 bits are turned OFF automatically.

Bit 8: When backup is complete (normal completion), it is turned ON. When an error occurs, it is turned OFF.

Bit 9: When restore is complete (normal completion), it is turned ON. When an error occurs, it is turned OFF.

The other bits are reserved.

H	0	0	0	0	0	0	0	0	0	0	0	0	0	0	0	0
L	0	0	0	0	Keep Variable Backup Completion Bit	0	0	0	0	Keep Variable Backup Request Bit						

Keep Variable Backup Request Bit

0	0	Restore Execution	Backup Execution
---	---	-------------------	------------------

Bit	OFF	ON
Backup Execution	None	Request (Backup of variable)
Restore Execution	None	Request (Restore of variable)

After execution, it is turned OFF automatically.

When the request bits are simultaneously turned ON, restore is executed after the backup.

Keep Variable Backup Completion Bit

0	0	Restore Completion	Backup Completion
---	---	--------------------	-------------------

Bit	OFF	ON
Backup Completion	None	Completion Notice
Restore Completion	None	Completion Notice

- NOTE**
- You cannot backup in offline mode or transfer mode.
 - You can only restore the same project that you backed up. If it is a different project, restore will not execute.
 - When you execute backup and restore sequentially, the screen display speed may slow, or the online logic monitor may discontinue. Also, depending on the project, communication may be affected. When you allocate #L_BackupCmd to the switch parts, specify the [Bit Set] and do not touch continuously. Do not backup or restore on the D-Script using #L_BackupCmd.
 - You can back up only when Logic is stopped.

A.6.2 HMI system variables (#H system variables)

■ Bit type

Variable Name	Description	Read	Write
#H_Alarm_Trigger	The alarm is triggered (regardless of the particulars that occurred)	O	O
#H_Control_Buzzer	Buzzer Output	O	O
#H_Control_BuzzerEnable	Enable the Buzzer Output	O	O
#H_Control_HardcopyPrint	Print Control for Screen Hard Copy	O	O
#H_Control_JpegCaptureEnable	Enable Screen Capture	O	O
#H_Control_JpegCaptureTrigger	Control of Screen Capture	O	O
#H_Control_PrintCancel	Control of Print Cancel	O	O
#H_Control_USBDetachTrigger	USB Removal Control ^{*1}	O	O
#H_Control_SecureWriteTrigger	Starts writing security data ^{*2}	O	O
#H_Control_SecureWriteMode	Security Data Write Mode	O	O
#H_Control_SecureDeleteMode	Security Data Delete Mode	O	O
#H_Control_SecureReadDevice	Location where security data is read from	O	O
#H_Status_SecureWriteProcess	Writing security data	O	X
#H_Status_SecureWriteCompletion	Writing security data completed	O	X
#H_DeviceMonitor	Device Monitor Start	O	O
[PLC*]#H_ErrorStatus	Communication error status of PLC (Device*)	O	X
#H_Expression_BCD_Err ^{*3}	BCD error during animation operation	O	O
#H_Expression_Division_Err ^{*3}	Zero operation error during animation operation	O	O
#H_Expression_Overflow	Status when storing 64-bit signed values as 32-bit signed values	O	O
#H_IsLockedState	Operation locked	O	X
#H_IsLockOwner	Operation Lock resides in the operating Server/Viewer or Master/Slave	O	X
#H_IsAutoUnlockTimerMoved	Operational check of Auto Unlock Timer.	O	X
#H_LadderMonitor	Ladder Monitor Start ^{*4} (None cache start)	O	O
#H_LadderMonitorCache	Ladder Monitor Start ^{*4} (Enable cache start)	O	O
#H_IsMasterDispUnit	Master station of Ethernet Multilink	O	X
#H_IsSlaveDispUnit	Slave station of Ethernet Multilink	O	X
H_Reset	Resets the unit.	O	X

Continued

Variable Name	Description	Read	Write
#H_Status_DispOnOff	Display ON/OFF	O	X
#H_Status_JpegCaptureCompletion	Screen Capture Status (Completed)	O	X
#H_Status_JpegCaptureProcess	Screen Capture Status (Processing in Progress)	O	X
#H_Status_Print	Printer Status	O	X
#H_Status_SecureWriteProcess	Writing security data	O	X
#H_Status_SecureWriteCompletion	Writing security data completed	O	X
#H_Status_USBUUsing	Status while USB is in use ^{*1}	O	X
[PLC*]#H_ScanOffStatus ^{*5}	Scanning status of PLC (Device*)	O	X
[PLC*]#H_ScanOffControl ^{*5}	Scanning control of PLC (Device*)	O	X

*1 WinGP does not operate. #H_Status_USBUUsing is in the OFF state at all times. When #H_Control_USBDetachTrigger is turned ON, nothing operates.

The operation to insert and remove a USB storage device is as follows.

When you connect a USB storage device to the display, #H_Status_USBUUsing is ON.

When you remove a USB storage device, turn ON #H_Control_USBDetachTrigger.

When the USB storage device can be removed, #H_Status_USBUUsing turns OFF automatically.

When #H_Control_USBDetachTrigger is ON while writing the data from the USB storage device, #H_Status_USBUUsing does not turn OFF until data writing is complete.

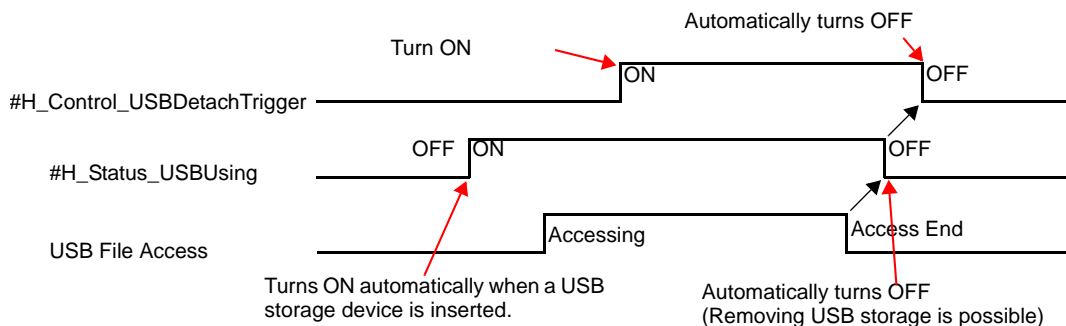

When #H_Status_USBUUsing is OFF, you cannot access the USB storage device. Remove the USB storage device and insert again.

Do not transfer to offline mode, transfer data to the display, or insert and remove the USB storage device while writing data to the USB storage. This may result in an incomplete file or damage to the USB storage device.

*2 For writing security data, refer to the following.

" Writing Security Data" (page A-111)

*3 If an error occurs right after changing screens, animation operates as follows.

Visibility Animation: Objects are hidden.

Position/Rotation Animation: Displays objects in original screen position.

Color Animation: When using Word Address or Numeric Expression, displays in the selected color. When using Bit Address or Bool Expression, displays the OFF color.

If an error occurs after drawing the front layer, the display remains in the same condition although drawings of other parts may erase all or a part of the display.

*4 To start the ladder monitor, refer to the "PLC Ladder Monitor Operation Manual" provided with your PLC's ladder monitor product (sold separately).

5 Name of the device is entered in [].

■ Integer type

Variable Name	Description	Read	Write
#H_BackLightColor	2-color Backlight Switching *1	O	O
#H_ChangeScreenNo	Change To Screen Number	O	O
#H_CounterbySecond	1-Second Binary Counter	O	X
#H_CurrentDay	Day Data (Current Value)	O	X
#H_CurrentDayofTheWeek	Day (Current Value) *2	O	X
#H_CurrentHour	Hours (Current Value)	O	X
#H_CurrentMinute	Minutes (Current Value)	O	X
#H_CurrentMonth	Month (Current Value)	O	X
#H_CurrentScreenNo	Current Screen Number	O	X
#H_CurrentSecond	Seconds (Current Value)	O	X
#H_CurrentYear	Years (Current Value)	O	X
#H_DisScanCounter	Display scan counter	O	X
#H_DisScanTime	Display Scan Time	O	X
#H_EtherLink_ConstCommuniMemInfo	Registration of constant communication between master and slave is displayed.	O	X
#H_EtherLink_ConstItemCount	Constant communication traffic is displayed that has been actually registered in the master.	O	X
#H_Expression_Err_Status	Error status during animation operation	O	O
#H_GlobalWindowControl	Window Control	O	O
#H_GlobalWindowNo	Window Number	O	O
#H_GlobalWindowPosX	Window Display Position (X)	O	O
#H_GlobalWindowPosY	Window Display Position (Y)	O	O
#H_JpegCaptureFileNo	Screen Capture File	O	O
#H_LockElapsedTime	Elapsed time (second) since Operation Lock is started.	O	X
#H_LockRemainderTime	Remaining time (second) for Operation Lock	O	X
#H_LockOwnerIPAddr	IP address of the location of Operation Lock	O	X
#H_LoginUserID	User ID for current user	O	X

Continued

Variable Name	Description	Read	Write
#H_MachineNo	Model number set through a conversion adapter	O	X
#H_SecurityWriteControl	Writes security data ^{*3}	O	O
#H_SecurityWriteStatus	Security data writing status	O	X
#H_SetDay	Day (Preset Value)	O	O
#H_SetHour	Hours (Preset Value)	O	O
#H_SetMinute	Minutes (Preset Value)	O	O
#H_SetMonth	Month (Preset Value)	O	O
#H_SetSecond	Seconds (Preset Value)	O	O
#H_SetYear	Year (Preset Value)	O	O
[PLC*]#H_DriverCycleTime ^{*4}	Cycle time of PLC (Device*)	O	X
[PLC*]#H_IsLockedState ^{*4}	Error code of PLC (Device*)	O	X
[PLC*]#H_IsLockedCount ^{*4}	The number of errors of PLC (Device*)	O	X
[PLC*]#H_DriverErrorDate	Date of errors of PLC (Device*)	O	X

- *1 It operates only on models that support 2-color backlight switching. See "1.3 Supported Features" (page 1-5). When you write "0", it is amber and "1" is red. Do not set other colors.
- *2 The current value for the day is stored in LS9310. See A.1.4.2 System Data Area , Clock Data (Current) on (page A-18) for the stored value.
- *3 For details on writing security data, refer to the following.
- *4 Name of the device is entered in [*].

Writing Security Data

Passwords can be reflected on the display unit using integer-type or bit-type system variables for writing security data.

Completion of this operation (writing) can be detected by system variables for status.

- Starts Writing Security Data (#H_Control_SecureWriteTrigger)

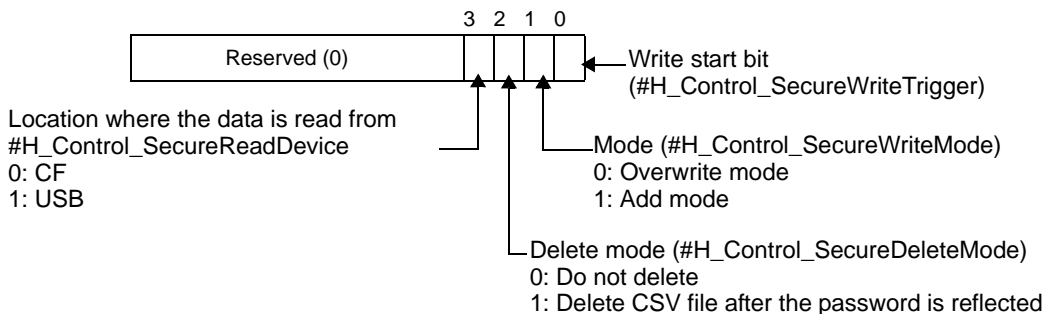

The password of the CSV file is reflected on the display unit by turning the bit 0 to ON from OFF.

- Write error check

When writing to the display unit, check the following items for Level Mode/User ID Mode and Write Mode.

O: Check errors X: Do not check errors

Contents to be checked	Level Mode		User ID Mode	
	Overwrite	Add	Overwrite	Add
CF/USB is mounted on the display unit.	O	O	O	O
CSV file has a designated path and file name.	O	O	O	O
CSV file is in a designated format.	O	O	O	O
Password data of the CSV file is free of the following error.	-	-	-	-
• Password (including the level and user ID) is described using up to eight single-byte characters.	O	O	O	O
• Password (including the level and user ID) does not include a space.	O	O	O	O
• Level, password and user ID have no errors (if they are described with spaces only, they are regarded as being deleted, instead of being an error).	X	X	O	O
• Levels are within a range of 1 - 15.	X	X	O	O
The number of set user IDs is not more than 64.*1	X	X	O	O
Level Mode /User ID Mode of the CSV file is consistent with that on the display unit.	O	O	O	O
User ID (password) is not duplicated.*2	O	O	O	O

The contents to be checked are different depending on Write Mode.

*1 Checking the number of set User IDs

Overwrite	Check the number of settings in the file for writing.
Add	Check the sum of the number of settings in the data to write and the existing data.

*2 Checking data duplication

Level Mode	Overwrite	Check that the password is not duplicated within the file for writing.
	Add	Check above and that the password is not duplicated between the data to write and the existing data.

User ID Mode	Over-write	Check that the ID is not duplicated within the file for writing.
	Add	Check above and that the ID is not duplicated between the data to write and the existing data.

- Security Data Writing Status (#H_SecurityWriteStatus)

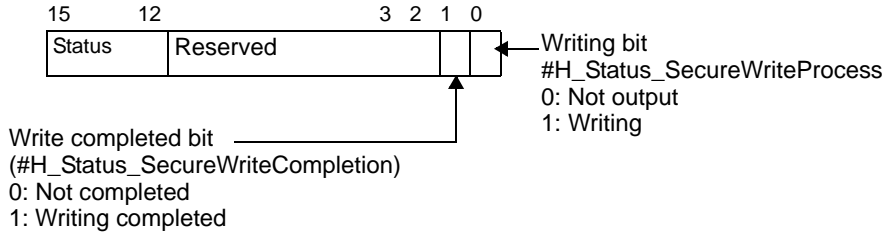

Details of status

Bit 12 to 15	Description	Details
0000	Completed Successfully	Writing to the display unit is successfully completed
0001	Reserved	
0010	Reserved	
0011	Reserved	
0100	CF Card or USB Storage is absent	When writing to the display unit, a CF Card/USB storage is not inserted or the CF Card hatch is open.
0101	Delete Error	Failed to delete the CSV file.
0110	Reserved	
0111	Reserved	
1000	User IDs out of range	The number of user IDs exceeded 64 when writing to the display unit.
1001	Write data error	Failed to write data to NAND.
1010	CSV file name or path error	CSV file does not have a designated path or file name.
1011	CSV file format error	CSV file is not in a designated format.
1100	CSV data error	There is an error in the password data.
1101	Mode error	Level Mode or User ID Mode does not match that on the display unit.
1110	Duplication error	Password is duplicated (Level PS Mode). User ID is duplicated (User ID Mode).

- When writing is completed, the writing bit automatically turns OFF and the write completed bit turns ON at the same time.
When the user turns OFF the write start bit, the completed bit automatically turns OFF.
- Even when you turn OFF the write start bit before the write completed bit turns ON, the write completed bit is automatically turned OFF.
- When an error has occurred when writing, the completed bit does not turn ON. The writing bit turns OFF, and an error status is stored in HMI system variable #H_SecurityWriteStatus. Even if the write start bit is turned OFF, the status is not cleared automatically. It will be cleared next time the process is completed successfully.