



Hi4 Robot Driver

1	System Configuration.....	3
2	Selection of External Device	7
3	Example of Communication Setting	8
4	Setup Items	16
5	Cable Diagram	21
6	Supported Device.....	29
7	Device Code and Address Code.....	31
8	Error Messages	32

Introduction

This manual describes how to connect the Display and the External Device (target PLC).

In this manual, the connection procedure will be described by following the below sections:

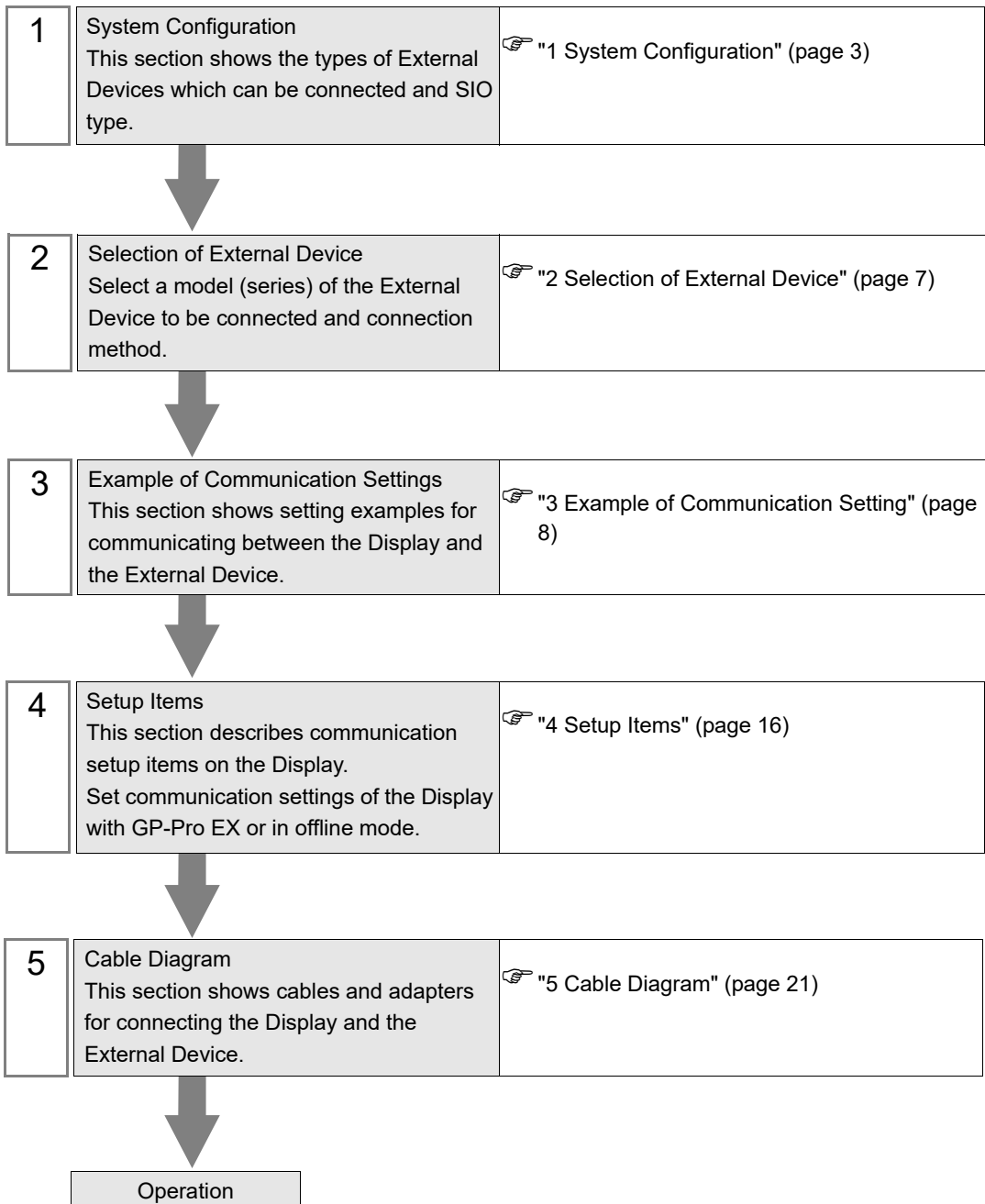

1 System Configuration

The system configuration in the case when the External Device of Hyundai Heavy Industries and the Display are connected is shown.

Series	CPU	Link I/F	SIO Type	Setting Example	Cable Diagram
Hi4 Robot	BD412 board	CNSIO port on CPU	RS-232C	"Setting Example 1" (page 8)	"Cable Diagram 1" (page 21)
		OPSIO port on CPU	RS-232C	"Setting Example 2" (page 10)	"Cable Diagram 2" (page 23)
			RS422/485 (4 wire)	"Setting Example 3" (page 13)	"Cable Diagram 3" (page 24)

■ Connection Configuration

- 1:1 connection

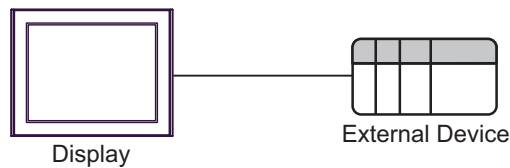

■ IPC COM Port

When connecting IPC with an External Device, the COM port used depends on the series and SIO type. Please refer to the IPC manual for details.

Usable port

Series	Usable Port		
	RS-232C	RS-422/485(4 wire)	RS-422/485(2 wire)
PS-2000B	COM1 ^{*1} , COM2, COM3 ^{*1} , COM4	-	-
PS-3450A, PS-3451A, PS3000-BA, PS3001-BD	COM1, COM2 ^{*1*2}	COM2 ^{*1*2}	COM2 ^{*1*2}
PS-3650A (T41 model), PS-3651A (T41 model)	COM1 ^{*1}	-	-
PS-3650A (T42 model), PS-3651A (T42 model)	COM1 ^{*1*2} , COM2	COM1 ^{*1*2}	COM1 ^{*1*2}
PS-3700A (Pentium®4-M) PS-3710A	COM1 ^{*1} , COM2 ^{*1} , COM3 ^{*2} , COM4	COM3 ^{*2}	COM3 ^{*2}
PS-3711A	COM1 ^{*1} , COM2 ^{*2}	COM2 ^{*2}	COM2 ^{*2}
PS4000 ^{*3}	COM1, COM2	-	-
PL3000	COM1 ^{*1*2} , COM2 ^{*1} , COM3, COM4	COM1 ^{*1*2}	COM1 ^{*1*2}
PE-4000B Atom N270	COM1, COM2	-	-
PE-4000B Atom N2600	COM1, COM2	COM3 ^{*4} , COM4 ^{*4} , COM5 ^{*4} , COM6 ^{*4}	COM3 ^{*4} , COM4 ^{*4} , COM5 ^{*4} , COM6 ^{*4}
PS5000 (Slim Panel Type Core i3 Model) ^{*5*6}	COM1, COM2 ^{*4}	COM2 ^{*4}	COM2 ^{*4}
PS5000 (Slim Panel Type Atom Model) ^{*5*6}	COM1, COM2 ^{*7}	COM2 ^{*7}	COM2 ^{*7}
PS5000 (Enclosed Panel Type) ^{*8}	COM1	-	-
PS5000 (Modular Type PFXPU/PFXPP) ^{*5*6} PS5000 (Modular Type PFXPL2B5-6)	COM1 ^{*7}	COM1 ^{*7}	COM1 ^{*7}
PS5000 (Modular Type PFXPL2B1-4)	COM1, COM2 ^{*7}	COM2 ^{*7}	COM2 ^{*7}
PS6000 (Advanced Box) PS6000 (Standard Box)	COM1 ^{*9}	*10	*10
PS6000 (Basic Box)	COM1 ^{*9}	COM1 ^{*9}	COM1 ^{*9}

*1 The RI/5V can be switched. Use the IPC's switch to change if necessary.

*2 Set up the SIO type with the DIP Switch. Please set up as follows according to SIO type to be used.

- *3 When making communication between an External Device and COM port on the Expansion slot, only RS-232C is supported. However, ER (DTR/CTS) control cannot be executed because of the specification of COM port.
For connection with External Device, use user-created cables and disable Pin Nos. 1, 4, 6 and 9. Please refer to the IPC manual for details of pin layout.
- *4 Set up the SIO type with the BIOS. Please refer to the IPC manual for details of BIOS.
- *5 When setting up communication between an External Device and the RS-232C/422/485 interface module, use the IPC (RS-232C) or PS5000 (RS-422/485) cable diagrams. However, when using PFXZPBMPR42P2 in a RS-422/485 (4-wire) configuration with no flow control, connect 7.RTS+ and 8.CTS+, and connect 6.RTS- and 9.CTS-.
When using RS-422/485 communication with External Devices, you may need to reduce the transmission speed and increase the TX Wait time.
- *6 To use RS-422/485 communication on the RS-232C/422/485 interface module, the DIP Switch setting is required. Please refer to "Knowledge Base" (FAQs) on the support site. (<http://www.pro-face.com/trans/en/manual/1001.html>)

Settings	FAQ ID
PFXZPBMPR42P2, RS422/485 change method	FA263858
PFXZPBMPR42P2 termination resistor setting	FA263974
PFXZPBMPR44P2, RS422/485 change method	FA264087
PFXZPBMPR44P2 termination resistor setting	FA264088

- *7 Set up the SIO type with the DIP Switch. Please refer to the IPC manual for details of DIP Switch. The BOX Atom has not a switch to set the RS-232C, RS-422/485 mode. Use the BIOS for the setting.
- *8 For the connection with the External Device, on the user-created cable read as if the connector on the Display-side is a M12 A-coding 8 pin socket. The pin assignment is the same as described in the cable diagram. For the M12 A-coding connector, use PFXZPSCNM122.
- *9 In addition to COM1, you can also use the COM port on the optional interface.
- *10 Install the optional interface in the expansion slot.

DIP Switch settings (PL3000 / PS3000 Series)

RS-232C

DIP Switch	Setting	Description
1	OFF*1	Reserved (always OFF)
2	OFF	SIO type: RS-232C
3	OFF	
4	OFF	Output mode of SD (TXD) data: Always output
5	OFF	Terminal resistance (220Ω) insertion to SD (TXD): None
6	OFF	Terminal resistance (220Ω) insertion to RD (RXD): None
7	OFF	Short-circuit of SDA (TXA) and RDA (RXA): Not available
8	OFF	Short-circuit of SDB (TXB) and RDB (RXB): Not available
9	OFF	RS (RTS) Auto control mode: Disabled
10	OFF	

*1 When using PS-3450A, PS-3451A, PS3000-BA and PS3001-BD, turn ON the set value.

RS-422/485 (4 wire)

DIP Switch	Setting	Description
1	OFF	Reserved (always OFF)
2	ON	SIO type: RS-422/485
3	ON	
4	OFF	Output mode of SD (TXD) data: Always output
5	OFF	Terminal resistance (220Ω) insertion to SD (TXD): None
6	OFF	Terminal resistance (220Ω) insertion to RD (RXD): None
7	OFF	Short-circuit of SDA (TXA) and RDA (RXA): Not available
8	OFF	Short-circuit of SDB (TXB) and RDB (RXB): Not available
9	OFF	RS (RTS) Auto control mode: Disabled
10	OFF	

RS-422/485 (2 wire)

DIP Switch	Setting	Description
1	OFF	Reserved (always OFF)
2	ON	SIO type: RS-422/485
3	ON	
4	OFF	Output mode of SD (TXD) data: Always output
5	OFF	Terminal resistance (220Ω) insertion to SD (TXD): None
6	OFF	Terminal resistance (220Ω) insertion to RD (RXD): None
7	ON	Short-circuit of SDA (TXA) and RDA (RXA): Available
8	ON	Short-circuit of SDB (TXB) and RDB (RXB): Available
9	ON	RS (RTS) Auto control mode: Enabled
10	ON	

2 Selection of External Device

Select the External Device to be connected to the Display.

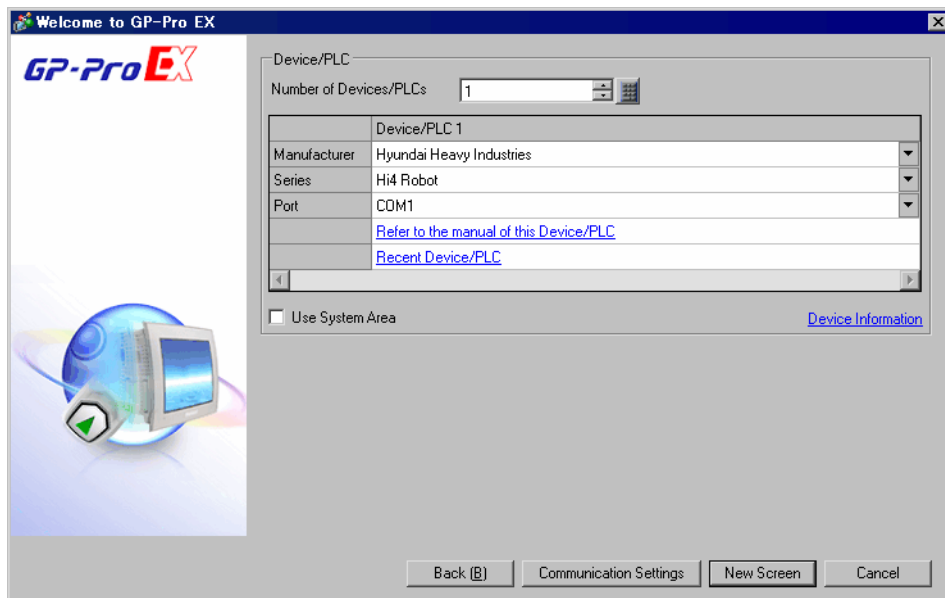

Setup Items	Setup Description
Number of Devices/PLCs	Enter an integer from 1 to 4 to define the number of Devices/PLCs to connect to the display.
Manufacturer	Select the manufacturer of the External Device to connect. Select "Hyundai Heavy Industries".
Series	Select the External Device model (series) and the connection method. Select "Hi4 Robot". In System configuration, make sure the External Device you are connecting is supported by "Hi4 Robot".  "1 System Configuration" (page 3)
Port	Select the Display port to be connected to the External Device.
Use System Area	Check this option to synchronize the system data area of the Display and the device (memory) of the External Device. When synchronized, you can use the External Device's ladder program to switch the display or display the window on the Display. Cf. GP-Pro EX Reference Manual "LS Area (Direct Access Method Area)" This feature can also be set in GP-Pro EX or in the Display's offline mode. Cf. GP-Pro EX Reference Manual "System Settings [Display Unit] - [System Area] Settings Guide" Cf. Maintenance/Troubleshooting Guide "Main Unit - System Area Settings"

3 Example of Communication Setting

The following shows examples of communication settings of the Display and the External Device, which is recommended by Pro-face.

3.1 Setting Example 1

■ Settings of GP-Pro EX

◆ Communication Settings

To display the setup screen, from the [Project] menu, point to [System Settings] and select [Device/PLC].

◆ Device Setting

To display the [Individual Device Settings] dialog box, from [Device-Specific Settings] in the [Device/PLC] window, select the external device and click [Settings] .

To connect multiple External Devices, from [Device-Specific Settings] in the [Device/PLC] window, click [Add Device] to add another External Device.

■ Settings of External Device

Communication setting of External Device using DIP switches and Teach Pendant of External Device.

Please refer to the manual of the External Device for more details.

◆ DIP Switch Setting

Set the DIP switch for built-in PLC.

DIP switches	Settings
SW01	OFF
SW02	OFF
SW03	OFF
SW04	OFF
SW05	ON
SW06	OFF
SW07	OFF
SW08	OFF

◆ Teach Pendant Setting

- 1 Press [PF2].
- 2 Select [2: Controller parameter]-[2: Serial ports]-[3: Serial Port #1(CNSIO)] in order from the displayed menu so as to display [Serial Port 1].
- 3 Set the setup items as follows.

Setup Items	Setting Value
Baudrate	38400
Character length	8
Stop bit	1
Parity bit	Disable
Echo	Disable
Port Usage	MODBUS

- 4 Press [PF2].
- 5 Select [2: Controller parameter]-[18: MODBUS environment setting] to displayed [MODBUS setting].
- 6 Set the setup items as follows.

Setup Items	Setting Value
Transmission mode	RTU
Slave Address	1

- 7 Press [SET].

3.2 Setting Example 2

■ Settings of GP-Pro EX

◆ Communication Settings

To display the setup screen, from the [Project] menu, point to [System Settings] and select [Device/PLC].

Device/PLC 1

Summary [Change Device/PLC](#)

Manufacturer Series Port

Text Data Mode [Change](#)

Communication Settings

SIQ Type RS232C RS422/485(2wire) RS422/485(4wire)

Speed

Data Length 7 8

Parity NONE EVEN ODD

Stop Bit 1 2

Flow Control NONE ER(DTR/CTS) XON/XOFF

Timeout (sec)

Retry

Wait To Send (ms)

RI / VCC RI VCC

In the case of RS232C, you can select the 9th pin to RI (Input or VCC (5V Power Supply). If you use the Digital's RS232C Isolation Unit, please select it to VCC.

Device-Specific Settings

Allowable Number of Devices/PLCs [Add Device](#)

No.	Device Name	Settings
<input type="button" value="1"/>	<input type="text" value="PLC1"/>	<input type="text" value="Slave Address=1"/>

◆ Device Setting

To display the [Individual Device Settings] dialog box, from [Device-Specific Settings] in the [Device/PLC] window, select the external device and click [Settings] .

To connect multiple External Devices, from [Device-Specific Settings] in the [Device/PLC] window, click [Add Device] to add another External Device.

Individual Device Settings

PLC1

Slave Address

■ Settings of External Device

Communication setting of External Device using DIP switches and Teach Pendant of External Device.

Please refer to the manual of the External Device for more details.

◆ DIP Switch Setting

Set DIP switch for built-in PLC and DIP switch for OPSIO port

- DIP switch for built-in PLC

DIP switches	Settings
SW01	OFF
SW02	OFF
SW03	OFF
SW04	OFF
SW05	ON
SW06	OFF
SW07	OFF
SW08	OFF

- DIP switch for OPSIO port

DIP switch	Settings
SW01	ON
SW02	ON
SW03	OFF
SW04	OFF

◆ Teach Pendant Setting

- 1 Press [PF2].
- 2 Select [2: Controller parameter]-[2: Serial ports]-[3: Serial Port #1 (CNSIO)] in order from the displayed menu so as to display [Serial Port 1].
- 3 Set anything other than [MODBUS] to [Port Usage].
- 4 Select [4: Serial Port #2 (OPSIO)] in the same procedure so as to display [Serial Port 2].
- 5 Set the setup items as follows.

Setup Items	Setting Value
Baudrate	38400
Character length	8
Stop bit	1
Parity bit	Disable
Echo	Disable
Conv. RS422-RS485	Disable
Port Usage	MODBUS

- 6 Press [PF2].

7 Select [2: Controller parameter]-[18: MODBUS environment setting] to display [MODBUS setting].

8 Set the setup items as follows.

Setup Items	Setting Value
Transmission mode	RTU
Slave Address	1

9 Press [SET].

3.3 Setting Example 3

■ Settings of GP-Pro EX

◆ Communication Settings

To display the setup screen, from the [Project] menu, point to [System Settings] and select [Device/PLC].

Device/PLC 1

Summary [Change Device/PLC](#)

Manufacturer Series Port

Text Data Mode [Change](#)

Communication Settings

SIO Type RS232C RS422/485(2wire) RS422/485(4wire)

Speed

Data Length 7 8

Parity NONE EVEN ODD

Stop Bit 1 2

Flow Control NONE ER(DTR/CTS) XON/XOFF

Timeout (sec)

Retry

Wait To Send (ms)

RI / VCC RI VCC

In the case of RS232C, you can select the 9th pin to RI (Input or VCC (5V Power Supply). If you use the Digital's RS232C Isolation Unit, please select it to VCC.

Device-Specific Settings

Allowable Number of Devices/PLCs [Add Device](#)

No.	Device Name	Settings
<input type="button" value="1"/>	<input type="text" value="PLC1"/>	<input type="text" value="Slave Address=1"/>

◆ Device Setting

To display the [Individual Device Settings] dialog box, from [Device-Specific Settings] in the [Device/PLC] window, select the external device and click [Settings] .

To connect multiple External Devices, from [Device-Specific Settings] in the [Device/PLC] window, click [Add Device] to add another External Device.

Individual Device Settings

PLC1

Slave Address

■ Settings of External Device

Communication setting of External Device using DIP switches and Teach Pendant of External Device.

Please refer to the manual of the External Device for more details.

◆ DIP Switch Setting

Set DIP switch for built-in PLC and DIP switch for OPSIO port.

- DIP switch for built-in PLC

DIP switches	Settings
SW01	OFF
SW02	OFF
SW03	OFF
SW04	OFF
SW05	ON
SW06	OFF
SW07	OFF
SW08	OFF

- DIP switch for OPSIO port

DIP switch	Settings
SW01	OFF
SW02	OFF
SW03	ON
SW04	ON

◆ Teach Pendant Setting

- 1 Press [PF2].
- 2 Select [2: Controller parameter]-[2: Serial ports]-[3: Serial Port #1(CNSIO)] in order from the displayed menu so as to display [Serial Port 1].
- 3 Set anything other than [MODBUS] to [Port Usage].
- 4 Select [4: Serial Port #2 (OPSIO)] in the same procedure so as to display [Serial Port 2].
- 5 Set the setup items as follows.

Setup Items	Setting Value
Baudrate	38400
Character length	8
Stop bit	1
Parity bit	Disable
Echo	Disable
Conv. RS422-RS485	Disable
Port Usage	MODBUS

- 6 Press [PF2].

7 Select [2: Controller parameter]-[18: MODBUS environment setting] to display [MODBUS setting].

8 Set the setup items as follows.

Setup Items	Setting Value
Transmission mode	RTU
Slave Address	1

9 Press [SET].

4 Setup Items

Set communication settings of the Display with GP-Pro EX or in offline mode of the Display.

The setting of each parameter must be identical to that of External Device.

☞ "3 Example of Communication Setting" (page 8)

4.1 Setup Items in GP-Pro EX

■ Communication Settings

To display the setup screen, from the [Project] menu, point to [System Settings] and select [Device/PLC].

Device/PLC 1

Summary [Change Device/PLC](#)

Manufacturer Series Port

Text Data Mode [Change](#)

Communication Settings

SIO Type RS232C RS422/485(2wire) RS422/485(4wire)

Speed

Data Length 7 8

Parity NONE EVEN ODD

Stop Bit 1 2

Flow Control NONE ER(DTR/CTS) XON/XOFF

Timeout (sec)

Retry

Wait To Send (ms)

RI / VCC RI VCC

In the case of RS232C, you can select the 9th pin to RI (Input) or VCC (5V Power Supply). If you use the Digital's RS232C Isolation Unit, please select it to VCC.

Device-Specific Settings

Allowable Number of Devices/PLCs [Add Device](#)

No.	Device Name	Settings	Add Indirect Device
1	PLC1	Slave Address=1	<input type="button" value="+"/>

Setup Items	Setup Description
SIO Type	Select the SIO type to communicate with the External Device.
Speed	Select speed between the External Device and the Display.
Data Length	Display data length.
Parity	Select how to check parity.
Stop Bit	Select stop bit length.
Flow Control	Select the communication control method to prevent overflow of transmission and reception data.
Timeout	Use an integer from 1 to 127 to enter the time (s) for which the Display waits for the response from the External Device.
Retry	In case of no response from the External Device, use an integer from 0 to 255 to enter how many times the Display retransmits the command.
Wait To Send	Use an integer from 0 to 255 to enter standby time (ms) for the Display from receiving packets to transmitting next commands.

Continues to the next page.

Setup Items	Setup Description
RI/VCC	You can switch RI/VCC of the 9th pin when you select RS232C for SIO type. It is necessary to change RI/5V by changeover switch of IPC when connect with IPC. Please refer to the manual of the IPC for more detail.

NOTE

- Refer to the GP-Pro EX Reference Manual for Indirect Device.

Cf. GP-Pro EX Reference Manual "Changing the Device/PLC at Runtime (Indirect Device)"

■ Device Setting

To display the [Individual Device Settings] dialog box, from [Device-Specific Settings] in the [Device/PLC] window, select the external device and click [Settings] .

To connect multiple External Devices, from [Device-Specific Settings] in the [Device/PLC] window, click [Add Device] to add another External Device.

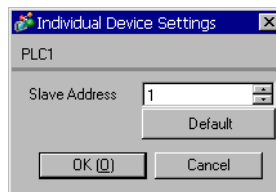

Setup Items	Setup Description
Slave Address	Use an integer from 1 to 247 to enter the address of the External Device.

4.2 Setup Items in Offline Mode

NOTE

- Refer to the Maintenance/Troubleshooting guide for information on how to enter offline mode or about the operation.

Cf. Maintenance/Troubleshooting Guide "Offline Mode"

- The number of the setup items to be displayed for 1 page in the offline mode depends on the Display in use. Please refer to the Reference manual for details.

■ Communication Settings

To display the setting screen, touch [Device/PLC Settings] from [Peripheral Settings] in offline mode. Touch the External Device you want to set from the displayed list.

Comm.	Device	Option		
Hi4 Robot			[COM1]	Page 1/1
SIO Type		RS232C		
Speed		38400		
Data Length		8		
Parity		<input checked="" type="radio"/> NONE <input type="radio"/> EVEN <input type="radio"/> ODD		
Stop Bit		<input checked="" type="radio"/> 1 <input type="radio"/> 2		
Flow Control		NONE		
Timeout(s)		3	▼ ▲	
Retry		2	▼ ▲	
Wait To Send(ms)		0	▼ ▲	
	Exit		Back	2007/11/01 16:44:41

Setup Items	Setup Description
SIO Type	Select the SIO type to communicate with the External Device. IMPORTANT To make the communication settings correctly, confirm the serial interface specifications of Display unit for [SIO Type]. We cannot guarantee the operation if a communication type that the serial interface does not support is specified. For details concerning the serial interface specifications, refer to the manual for Display unit.
Speed	Select speed between the External Device and the Display.
Data Length	Display data length.
Parity	Select how to check parity.
Stop Bit	Select stop bit length.
Flow Control	Select the communication control method to prevent overflow of transmission and reception data.

Continues to the next page.

Setup Items	Setup Description
Timeout (s)	Use an integer from 1 to 127 to enter the time (s) for which the Display waits for the response from the External Device.
Retry	In case of no response from the External Device, use an integer from 0 to 255 to enter how many times the Display retransmits the command.
Wait To Send (ms)	Use an integer from 0 to 255 to enter standby time (ms) for the Display from receiving packets to transmitting next commands.

■ Device Settings

To display the setting screen, touch [Device/PLC Settings] from [Peripheral Settings]. Touch the External Device you want to set from the displayed list, and touch [Device Settings].

Setup Items	Setup Description
Device/PLC name	Select the External Device to set. Device name is a title of the External Device set with GP-Pro EX. (Initial value [PLC1])
Slave Address	Use an integer from 1 to 247 to enter the address of the External Device.

■ Option

To display the setting screen, touch [Device/PLC Settings] from [Peripheral Settings]. Touch the External Device you want to set from the displayed list, and touch [Option].

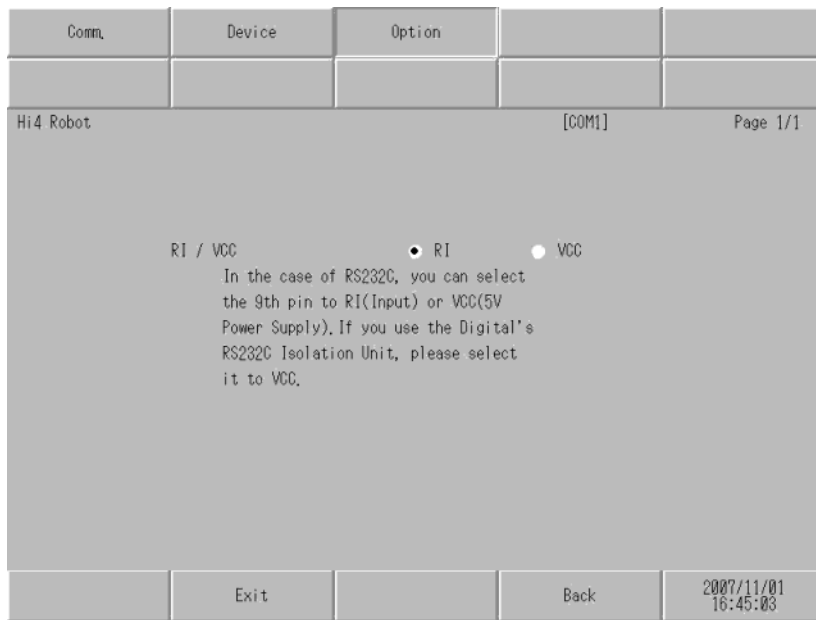

Setup Items	Setup Description
RI/VCC	Switches RI/VCC of the 9th pin. It is necessary to change RI/5V by changeover switch of IPC when connect with IPC. Please refer to the manual of the IPC for more detail.

NOTE

- GP-4100 series, GP-4*01TM and GP-Rear Module do not have the [Option] setting in the offline mode.

5 Cable Diagram

The cable diagram shown below may be different from the cable diagram recommended by Hyundai Heavy Industries. Please be assured there is no operational problem in applying the cable diagram shown in this manual.

- The FG pin of the External Device body must be D-class grounded. Please refer to the manual of the External Device for more details.
- SG and FG are connected inside the Display. When connecting SG to the External Device, design the system not to form short-circuit loop.
- Connect the isolation unit, when communication is not stabilized under the influence of a noise etc.

Cable Diagram 1

Display (Connection Port)	Cable		Notes
GP3000 (COM1) GP4000* ¹ (COM1) SP5000* ² (COM1/2) SP-5B00 (COM1) ST (COM1) LT3000 (COM1) IPC* ³ PC/AT	1A	Your own cable	Cable length: 15m or less
GP-4115T (COM1) GP-4115T3 (COM1)	1B	Your own cable	Cable length: 15m or less

*1 All GP4000 models except GP-4100 Series and GP-4203T

*2 Except SP-5B00

*3 Only the COM port which can communicate by RS-232C can be used.
☞ "■ IPC COM Port" (page 4)

1A)

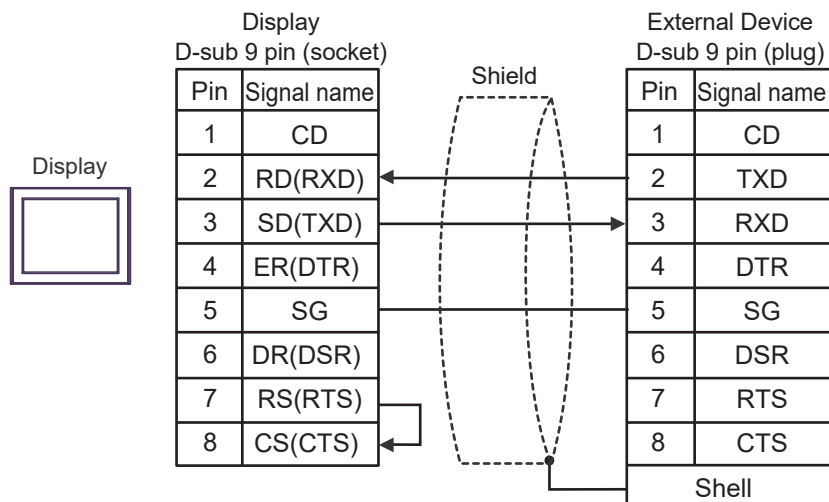

1B)

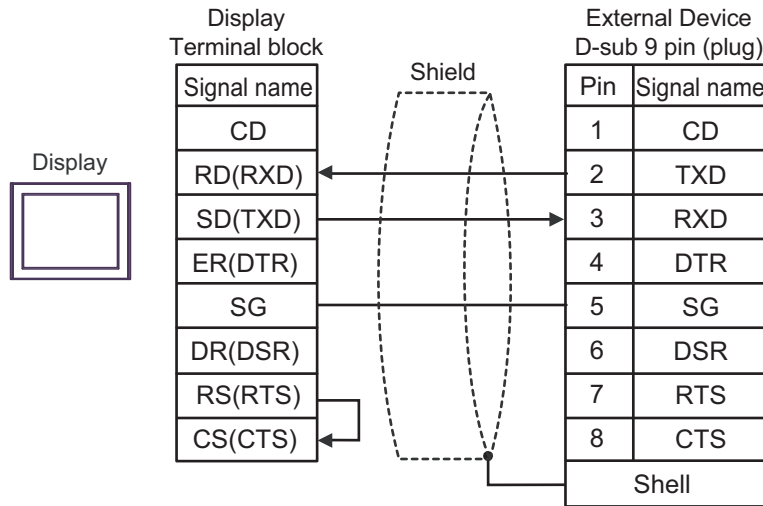

Cable Diagram 2

Display (Connection Port)	Cable		Notes
GP3000 (COM1) GP4000* ¹ (COM1) SP5000* ² (COM1/2) SP-5B00 (COM1) ST (COM1) LT3000 (COM1) IPC* ³ PC/AT	2A	Your own cable	Cable length: 15m or less
GP-4115T (COM1) GP-4115T3 (COM1)	2B	Your own cable	Cable length: 15m or less

*1 All GP4000 models except GP-4100 Series and GP-4203T

*2 Except SP-5B00

*3 Only the COM port which can communicate by RS-232C can be used.

☞ "■ IPC COM Port" (page 4)

2A)

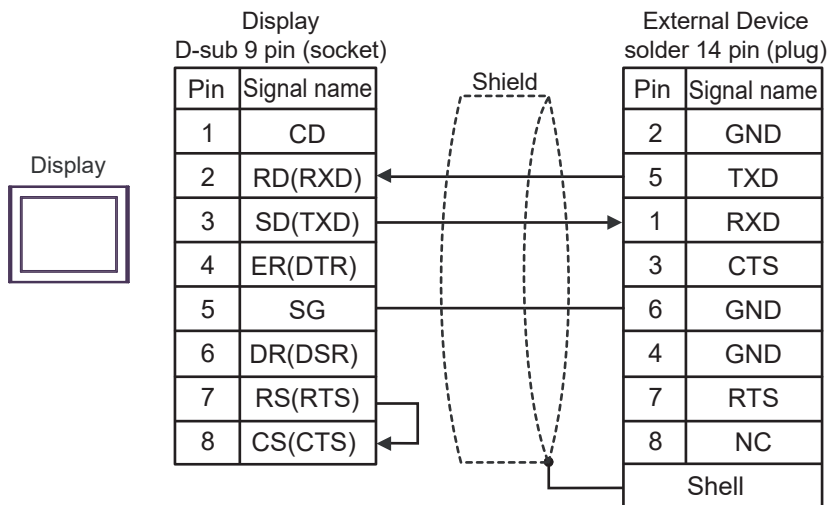

2B)

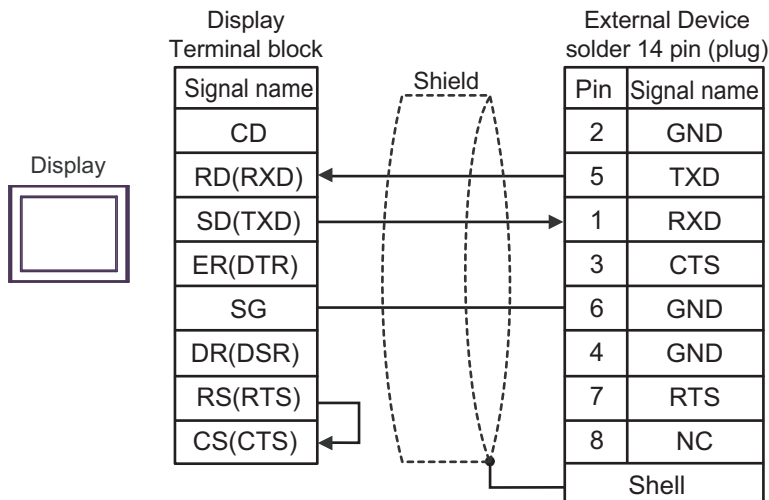

Cable Diagram 3

Display (Connection Port)	Cable		Notes
GP3000* ¹ (COM1) AGP-3302B (COM2) GP-4*01TM (COM1) GP-Rear Module (COM1) ST* ² (COM2) LT3000 (COM1) IPC* ³	3A	COM port conversion adapter by Pro-face CA3-ADPCOM-01 + Terminal block conversion adapter by Pro-face CA3-ADPTRM-01 + Your own cable	Cable length: 500m or less
	3B	Your own cable	
GP3000* ⁴ (COM2)	3C	Online adapter by Pro-face CA4-ADPONL-01 + Terminal block conversion adapter by Pro-face CA3-ADPTRM-01 + Your own cable	Cable length: 500m or less
	3D	Online adapter by Pro-face CA4-ADPONL-01 + Your own cable	
GP-4116T (COM1)	3G	Your own cable	Cable length: 500m or less
GP4000* ⁵ (COM2) GP-4201T (COM1) SP5000* ⁶ (COM1/2) SP-5B00 (COM2) PS6000 (Basic Box) (COM1/2)	3E	RS-422 Terminal Block Conversion Adapter by Pro-face PFXZCBADTM1* ⁷ + Your own cable	Cable length: 500m or less
	3B	Your own cable	
PE-4000B* ⁸ PS5000* ⁸ PS6000 (Optional Interface)* ⁸	3F	Your own cable	Cable length: 500m or less

*1 All GP models except AGP-3302B

*2 All ST models except AST-3211A and AST-3302B

*3 Only the COM port which can communicate by RS-422/485 (4 wire) can be used. (Except PE-4000B, PS5000, and PS6000)

 "■ IPC COM Port" (page 4)

*4 All GP models except GP-3200 series and AGP-3302B

*5 All GP4000 models except GP-4100 Series, GP-4*01TM, GP-Rear Module, GP-4201T and GP-4*03T

*6 Except SP-5B00

*7 When using a Terminal Block Conversion Adapter (CA3-ADPTRM-01) instead of the RS-422 Terminal Block Conversion Adapter, refer to Cable Diagram 3A.

*8 Only the COM port which can communicate by RS-422/485 (4 wire) can be used.

 "■ IPC COM Port" (page 4)

3A)

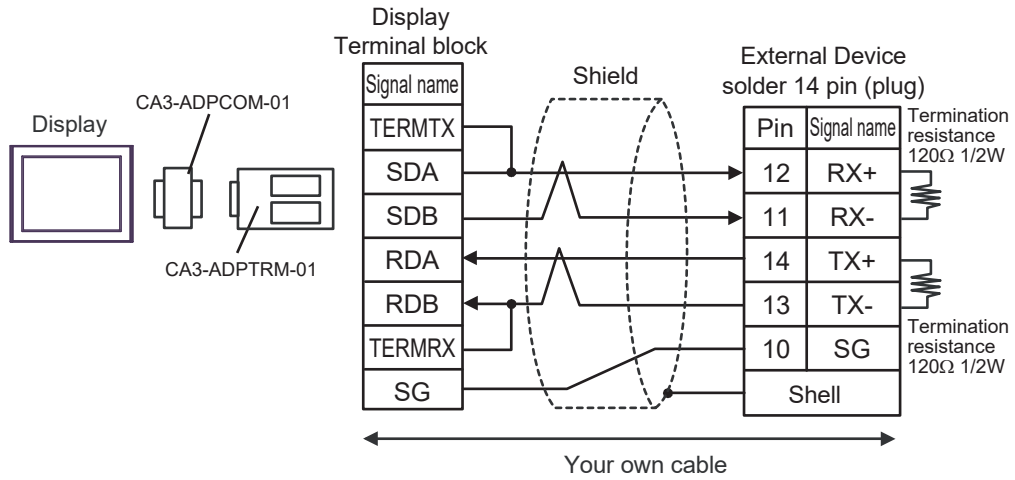

3B)

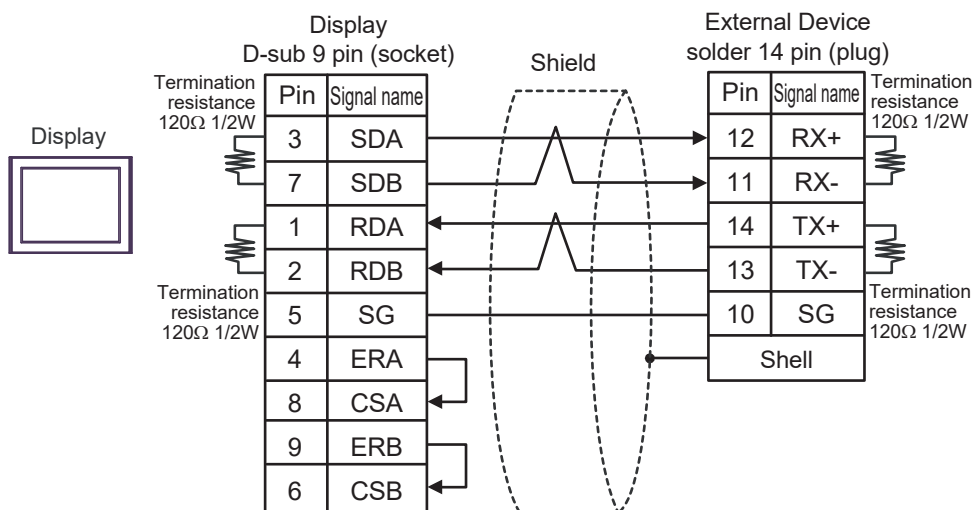

3C)

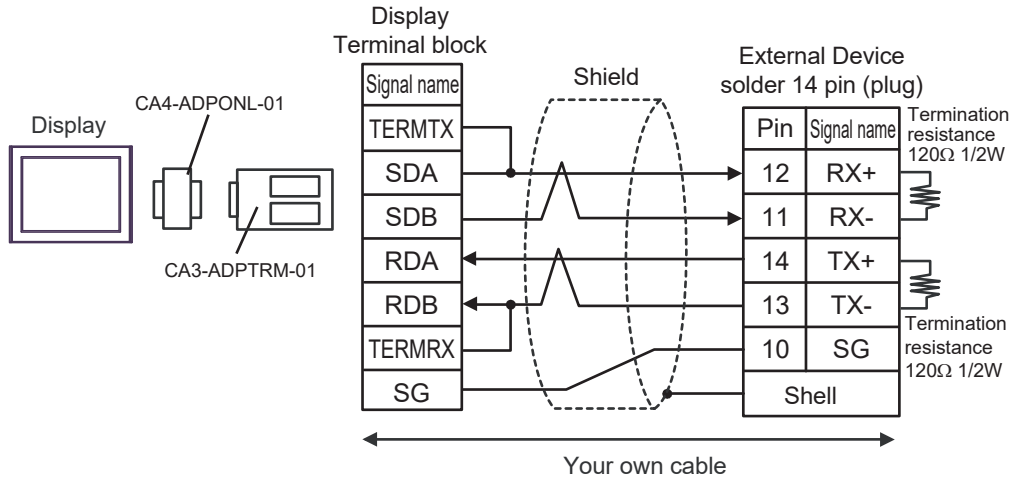

3D)

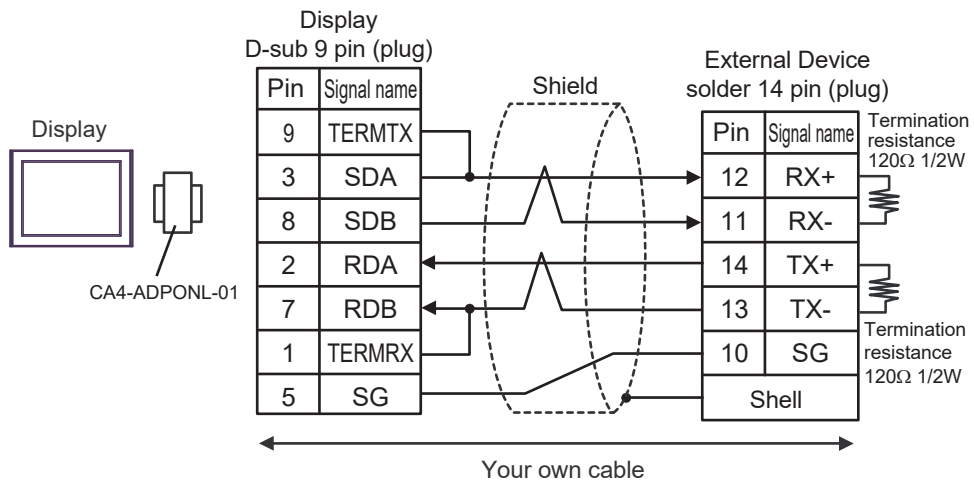

3E)

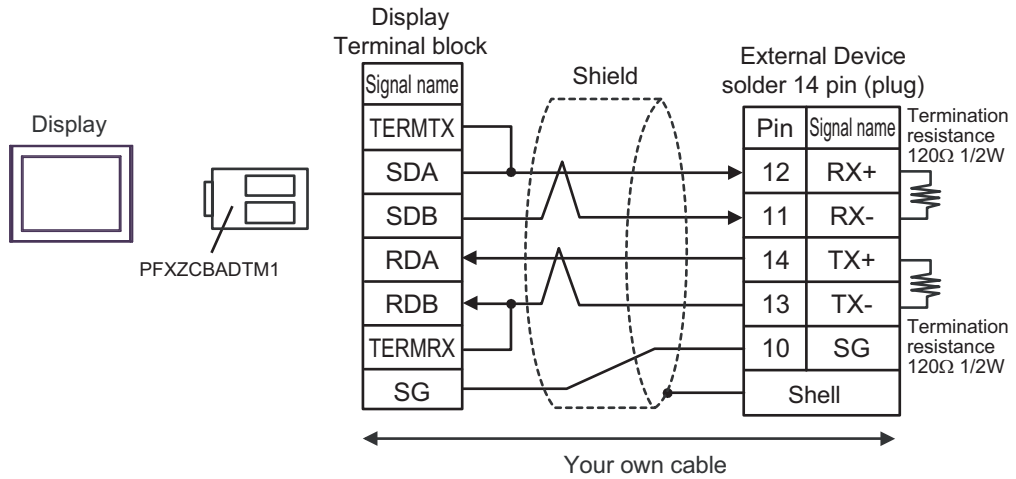

3F)

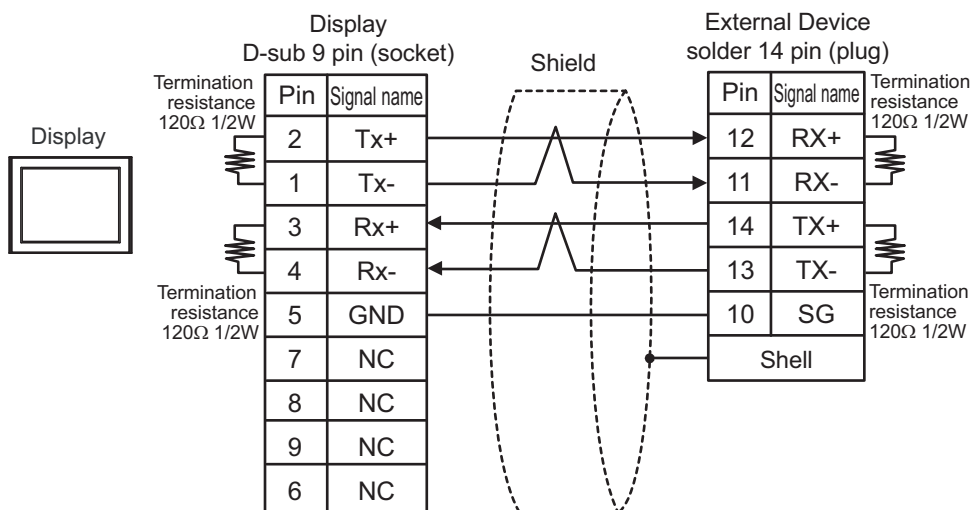

3G)

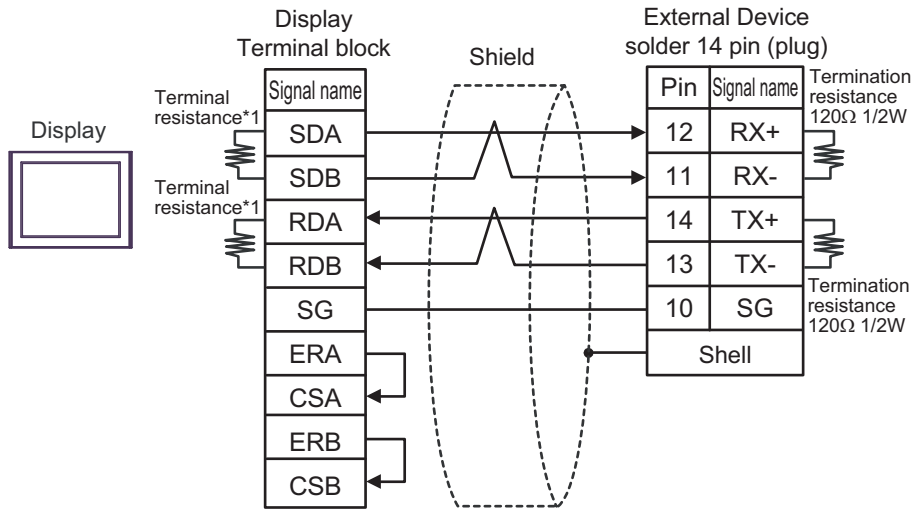



*1 The resistance in the Display is used as the termination resistance. Set the value of the DIP Switch on the rear of the Display as shown in the table below.

DIP Switch No.	Set Value
1	ON
2	ON
3	ON
4	ON

6 Supported Device

Range of supported device address is shown in the table below.

 This address can be specified as system data area.

Device	Bit Address	Word Address	32bits	Notes
External Input	X001 - X256	XW01 - XW16	H/L	*1, *2
PLC Input	DO001 - DO256	DOW01 - DOW16		*1, *2
Fieldbus Input #1	FB1.X001 - FB1.X960	FB1.XW01 - FB1.XW60		*1, *2
Fieldbus Input #2	FB2.X001 - FB2.X960	FB2.XW01 - FB2.XW60		*1, *2
Fieldbus Input #3	FB3.X001 - FB3.X960	FB3.XW01 - FB3.XW60		*1, *2
Fieldbus Input #4	FB4.X001 - FB4.X960	FB4.XW01 - FB4.XW60		*1, *2
Timer(Contact)	T001 - T256	-		*1, *2
Counter(Contact)	C001 - C256	-		*1, *2
Analog Input	-	AI1 - AI4		*2, *3, *4
External Output	Y001 - Y256	YW01 - YW16		*1
PLC Output	DI001 - DI256	DIW01 - DIW16		*1
Fieldbus Output #1	FB1.Y001 - FB1.Y960	FB1.YW01 - FB1.YW60		*1
Fieldbus Output #2	FB2.Y001 - FB2.Y960	FB2.YW01 - FB2.YW60		*1
Fieldbus Output #3	FB3.Y001 - FB3.Y960	FB3.YW01 - FB3.YW60		*1
Fieldbus Output #4	FB4.Y001 - FB4.Y960	FB4.YW01 - FB4.YW60		*1
Special	SP01 - SP32	SPW1 - SPW2		*1
Auxiliary	R0001 - R1024	RW01 - RW64		*1
Keep	K0001 - K1024	KW01 - KW64		*1
Timer(Current Value)	-	TW001 - TW256		*1
Counter(Current Value)	-	CW001 - CW256		*1
Analog Output	-	AO1 - AO4		*3, *4
System Memory	-	SW001 -SW256		 *1
Shared Register	-	MW0001 - MW5000		 *1
HRBASIC V% Variable	-	V%001 - V%400		*1
RN Register for M-code	-	RN01 - RN16		*1
HRBASIC V\$ Variable	-	V\$01.00 - V\$40.17		*5, *6
HRBASIC V! Variable	-	V!001 - V!400		*4, *7

*1 Writing is enabled when ROM version of External Device is Hi4 ROM version 2007.01.26 or higher.

*2 Write disable

*3 AI/AO device uses real number of 12 bit of Hi4 Robot.

Data range is between -12.000 and +12.000, but figure between -12000 and 12000 is used on Display.

- *4 Can be used when ROM version of External Device in use is Hi4 ROM version 2007.02.06 or higher.
- *5 Writing cannot be executed when ROM version of External Device in use is Hi4 ROM version 2007.02.06 or lower.
- *6 Since the size of the HRBASIC V\$ variable is equivalent to 18 words, the HRBASIC V\$ variable is treated as an aggregate of 18 points of a 1 word device in the GP-Pro EX. When specifying the address in the GP-Pro EX, the device address in the word order is displayed.

V\$01.00

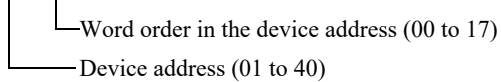

- *7 HRBASIC V! is a 32bit floating point.

NOTE

- Please refer to the GP-Pro EX Reference Manual for system data area.
Cf. GP-Pro EX Reference Manual "LS Area (Direct Access Method Area)"
- Please refer to the precautions on manual notation for icons in the table.

 "Manual Symbols and Terminology"

7 Device Code and Address Code

Use device code and address code when you select "Device Type & Address" for the address type in data displays.

Device	Device Name	Device Code (HEX)	Address Code
External Input	X / XW	0080	Word Address
PLC Input	DO / DOW	0082	Word Address
Fieldbus Input #1	FB1.X / FB1.XW	0083	Word Address
Fieldbus Input #2	FB2.X / FB2.XW	0084	Word Address
Fieldbus Input #3	FB3.X / FB3.XW	0085	Word Address
Fieldbus Input #4	FB4.X / FB4.XW	0086	Word Address
Analog Input	AI	0066	Word Address
External Output	Y / YW	0081	Word Address
PLC Output	DI / DIW	0087	Word Address
Fieldbus Output #1	FB1.Y / FB1.YW	0088	Word Address
Fieldbus Output #2	FB2.Y / FB2.YW	0089	Word Address
Fieldbus Output #3	FB3.Y / FB3.YW	008A	Word Address
Fieldbus Output #4	FB4.Y / FB4.YW	008B	Word Address
Special	SP / SPW	008C	Word Address
Auxiliary	R / RW	008D	Word Address
Keep	K / KW	008E	Word Address
Timer(Current Value)	TW	0060	Word Address
Counter(Current Value)	CW	0061	Word Address
Analog Output	AO	0067	Word Address
System Memory	SW	0001	Word Address
Shared Register	MW	0000	Word Address
HRBASIC V% Variable	V%	0062	Word Address
RN Register for M-code	RN	0063	Word Address
HRBASIC V\$ Variable	V\$	0064	Word Address
HRBASIC V! Variable	V!	0065	Word Address

8 Error Messages

Error messages are displayed on the screen of Display as follows: "No. : Device Name: Error Message (Error Occurrence Area)". Each description is shown below.

Item	Description
No.	Error No.
Device Name	Name of External Device where error occurs. Device name is a title of External Device set with GP-Pro EX. (Initial value [PLC1])
Error Message	Displays messages related to the error which occurs.
Error Occurrence Area	<p>Displays IP address or device address of External Device where error occurs, or error codes received from External Device.</p> <p>NOTE</p> <ul style="list-style-type: none"> • IP address is displayed such as "IP address (Decimal): MAC address (Hex)". • Device address is displayed such as "Address: Device address". • Received error codes are displayed such as "Decimal [Hex]".

Display Examples of Error Messages

"RHAA035:PLC1: Error has been responded for device write command (Error Code: 2 [02H])"

NOTE

- Refer to your External Device manual for details on received error codes.
- Refer to "Display-related errors" in "Maintenance/Troubleshooting Guide" for details on the error messages common to the driver.

■ Error Codes Unique to External Device

Error codes unique to External Device are shown below.

Error Code	Description
02H	Illegal data address.
03H	Illegal data value.