



# MICREX-SX Series SIO Driver

1	System Configuration.....	3
2	Selection of External Device .....	7
3	Example of Communication Setting.....	8
4	Setup Items.....	15
5	Cable Diagram .....	20
6	Supported Device.....	38
7	Device Code and Address Code.....	56
8	Error Messages.....	57

## Introduction

This manual describes how to connect the Display and the External Device (target PLC).

In this manual, the connection procedure will be described by following the below sections:

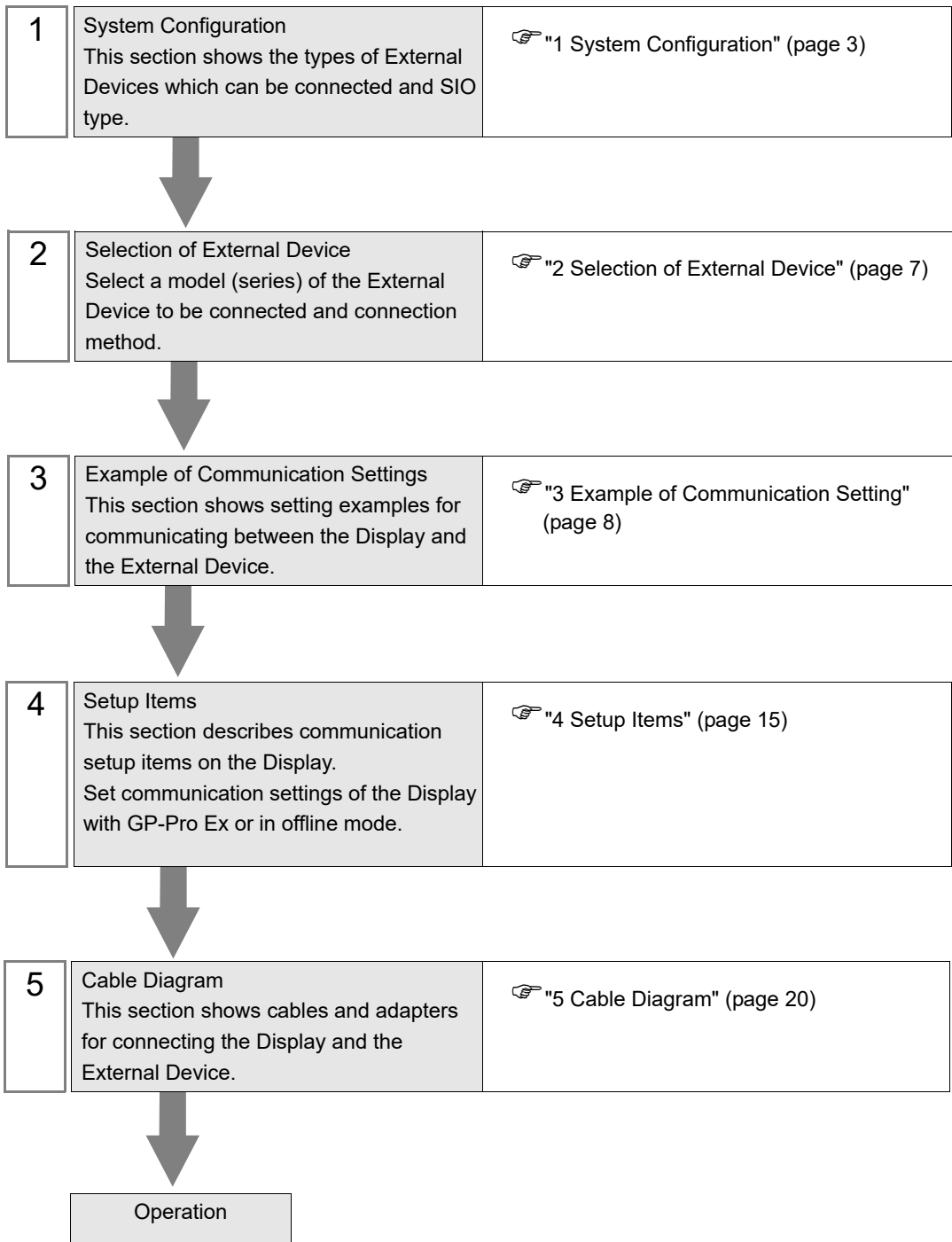

# 1 System Configuration

The system configuration in the case when the External Device of Fuji Electric Co., Ltd. and the Display are connected is shown.

Series	CPU	Link I/F	SIO Type	Setting Example	Cable Diagram
SPH	SPH200 (NP1PH-08 / NP1PH-16)  SPH300 (NP1PS-32 / NP1PS-32R / NP1PS-74 / NP1PS-74R / NP1PS-117 / NP1PS-117R)  SPH2000 (NP1PM-48E)	Loader Connection Connector on CPU unit	RS232C	"Setting Example 1" (page 8)	"Cable Diagram 1" (page 20)
		NP1L-RS1	RS232C	"Setting Example 2" (page 9)	"Cable Diagram 2" (page 22)
			RS422/485 (4wire)	"Setting Example 3" (page 10)	"Cable Diagram 3" (page 24)
		NP1L-RS2	RS232C	"Setting Example 2" (page 9)	"Cable Diagram 2" (page 22)
		NP1L-RS4	RS422/485 (4wire)	"Setting Example 3" (page 10)	"Cable Diagram 3" (page 24)
		NP1L-TL1 + FFK120A-C10 (RS232C interface)*1	RS232C	"Setting Example 4" (page 11)	"Cable Diagram 4" (page 30)
		NP1L-TL1 + FFK120A-C10 (RS485 interface)*1	RS422/485 (4wire)	"Setting Example 5" (page 13)	"Cable Diagram 5" (page 32)

\*1 Version 0604 or later interface is required.

## ■ Connection Configuration

- 1:1 Connection

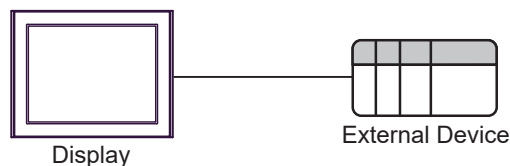

### NOTE

- Only one Display can be connected to one CPU or one Link I/F's SIO port.
- When 2 or more displays are connected to 2 or more CPUs and Link I/F's SIO ports, the error below may be displayed when 2 or more Displays are activated simultaneously.  
"Error has been responded for initial communication command (Error Code: [Hex])"  
If an error occurs, wait for 5 or more seconds to activate the Display.

## ■ IPC COM Port

When connecting IPC with an External Device, the COM port used depends on the series and SIO type. Please refer to the IPC manual for details.

### Usable port

Series	Usable Port		
	RS-232C	RS-422/485(4 wire)	RS-422/485(2 wire)
PS-2000B	COM1 <sup>*1</sup> , COM2, COM3 <sup>*1</sup> , COM4	-	-
PS-3450A, PS-3451A, PS3000-BA, PS3001-BD	COM1, COM2 <sup>*1*2</sup>	COM2 <sup>*1*2</sup>	COM2 <sup>*1*2</sup>
PS-3650A (T41 model), PS-3651A (T41 model)	COM1 <sup>*1</sup>	-	-
PS-3650A (T42 model), PS-3651A (T42 model)	COM1 <sup>*1*2</sup> , COM2	COM1 <sup>*1*2</sup>	COM1 <sup>*1*2</sup>
PS-3700A (Pentium®4-M) PS-3710A	COM1 <sup>*1</sup> , COM2 <sup>*1</sup> , COM3 <sup>*2</sup> , COM4	COM3 <sup>*2</sup>	COM3 <sup>*2</sup>
PS-3711A	COM1 <sup>*1</sup> , COM2 <sup>*2</sup>	COM2 <sup>*2</sup>	COM2 <sup>*2</sup>
PS4000 <sup>*3</sup>	COM1, COM2	-	-
PL3000	COM1 <sup>*1*2</sup> , COM2 <sup>*1</sup> , COM3, COM4	COM1 <sup>*1*2</sup>	COM1 <sup>*1*2</sup>
PE-4000B Atom N270	COM1, COM2	-	-
PE-4000B Atom N2600	COM1, COM2	COM3 <sup>*4</sup> , COM4 <sup>*4</sup> , COM5 <sup>*4</sup> , COM6 <sup>*4</sup>	COM3 <sup>*4</sup> , COM4 <sup>*4</sup> , COM5 <sup>*4</sup> , COM6 <sup>*4</sup>
PS5000 (Slim Panel Type Core i3 Model) <sup>*5*6</sup>	COM1, COM2 <sup>*4</sup>	COM2 <sup>*4</sup>	COM2 <sup>*4</sup>
PS5000 (Slim Panel Type Atom Model) <sup>*5*6</sup>	COM1, COM2 <sup>*7</sup>	COM2 <sup>*7</sup>	COM2 <sup>*7</sup>
PS5000 (Enclosed Panel Type) <sup>*8</sup>	COM1	-	-
PS5000 (Modular Type PFXPU/PFXPP) <sup>*5*6</sup> PS5000 (Modular Type PFXPL2B5-6)	COM1 <sup>*7</sup>	COM1 <sup>*7</sup>	COM1 <sup>*7</sup>
PS5000 (Modular Type PFXPL2B1-4)	COM1, COM2 <sup>*7</sup>	COM2 <sup>*7</sup>	COM2 <sup>*7</sup>
PS6000 (Advanced Box) PS6000 (Standard Box)	COM1 <sup>*9</sup>	*10	*10
PS6000 (Basic Box)	COM1 <sup>*9</sup>	COM1 <sup>*9</sup>	COM1 <sup>*9</sup>

\*1 The RI/5V can be switched. Use the IPC's switch to change if necessary.

\*2 Set up the SIO type with the DIP Switch. Please set up as follows according to SIO type to be used.

- \*3 When making communication between an External Device and COM port on the Expansion slot, only RS-232C is supported. However, ER (DTR/CTS) control cannot be executed because of the specification of COM port.  
For connection with External Device, use user-created cables and disable Pin Nos. 1, 4, 6 and 9. Please refer to the IPC manual for details of pin layout.
- \*4 Set up the SIO type with the BIOS. Please refer to the IPC manual for details of BIOS.
- \*5 When setting up communication between an External Device and the RS-232C/422/485 interface module, use the IPC (RS-232C) or PS5000 (RS-422/485) cable diagrams. However, when using PFXZPBMPR42P2 in a RS-422/485 (4-wire) configuration with no flow control, connect 7.RTS+ and 8.CTS+, and connect 6.RTS- and 9.CTS-.  
When using RS-422/485 communication with External Devices, you may need to reduce the transmission speed and increase the TX Wait time.
- \*6 To use RS-422/485 communication on the RS-232C/422/485 interface module, the DIP Switch setting is required. Please refer to "Knowledge Base" (FAQs) on the support site. (<http://www.pro-face.com/trans/en/manual/1001.html>)

Settings	FAQ ID
PFXZPBMPR42P2, RS422/485 change method	FA263858
PFXZPBMPR42P2 termination resistor setting	FA263974
PFXZPBMPR44P2, RS422/485 change method	FA264087
PFXZPBMPR44P2 termination resistor setting	FA264088

- \*7 Set up the SIO type with the DIP Switch. Please refer to the IPC manual for details of DIP Switch. The BOX Atom has not a switch to set the RS-232C, RS-422/485 mode. Use the BIOS for the setting.
- \*8 For the connection with the External Device, on the user-created cable read as if the connector on the Display-side is a M12 A-coding 8 pin socket. The pin assignment is the same as described in the cable diagram. For the M12 A-coding connector, use PFXZPSCNM122.
- \*9 In addition to COM1, you can also use the COM port on the optional interface.
- \*10 Install the optional interface in the expansion slot.

## DIP Switch settings (PL3000 / PS3000 Series)

### RS-232C

DIP Switch	Setting	Description
1	OFF*1	Reserved (always OFF)
2	OFF	SIO type: RS-232C
3	OFF	
4	OFF	Output mode of SD (TXD) data: Always output
5	OFF	Terminal resistance (220Ω) insertion to SD (TXD): None
6	OFF	Terminal resistance (220Ω) insertion to RD (RXD): None
7	OFF	Short-circuit of SDA (TXA) and RDA (RXA): Not available
8	OFF	Short-circuit of SDB (TXB) and RDB (RXB): Not available
9	OFF	RS (RTS) Auto control mode: Disabled
10	OFF	

\*1 When using PS-3450A, PS-3451A, PS3000-BA and PS3001-BD, turn ON the set value.

## RS-422/485 (4 wire)

DIP Switch	Setting	Description
1	OFF	Reserved (always OFF)
2	ON	SIO type: RS-422/485
3	ON	
4	OFF	Output mode of SD (TXD) data: Always output
5	OFF	Terminal resistance (220Ω) insertion to SD (TXD): None
6	OFF	Terminal resistance (220Ω) insertion to RD (RXD): None
7	OFF	Short-circuit of SDA (TXA) and RDA (RXA): Not available
8	OFF	Short-circuit of SDB (TXB) and RDB (RXB): Not available
9	OFF	RS (RTS) Auto control mode: Disabled
10	OFF	

## RS-422/485 (2 wire)

DIP Switch	Setting	Description
1	OFF	Reserved (always OFF)
2	ON	SIO type: RS-422/485
3	ON	
4	OFF	Output mode of SD (TXD) data: Always output
5	OFF	Terminal resistance (220Ω) insertion to SD (TXD): None
6	OFF	Terminal resistance (220Ω) insertion to RD (RXD): None
7	ON	Short-circuit of SDA (TXA) and RDA (RXA): Available
8	ON	Short-circuit of SDB (TXB) and RDB (RXB): Available
9	ON	RS (RTS) Auto control mode: Enabled
10	ON	

## 2 Selection of External Device

Select the External Device to be connected to the Display.

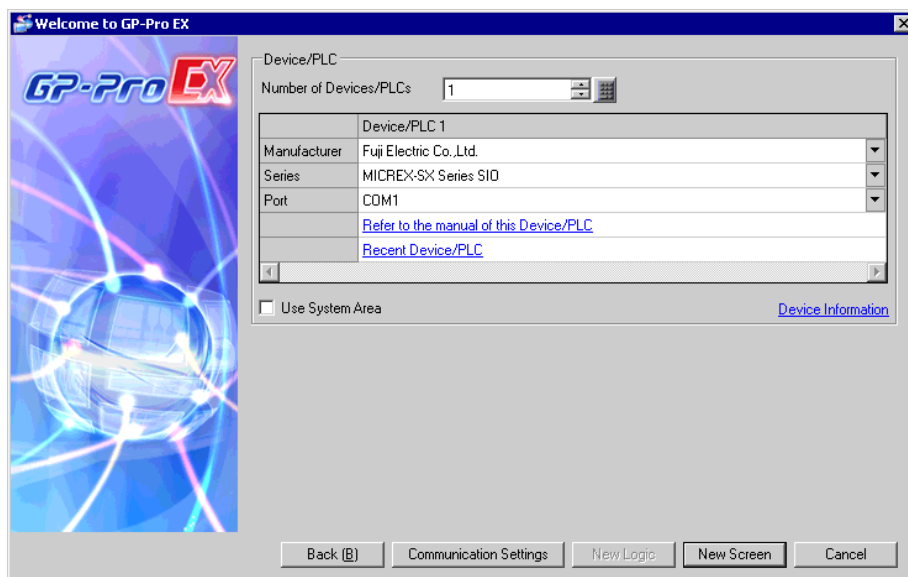

Setup Items	Setup Description
Number of Devices/PLCs	Enter an integer from 1 to 4 to define the number of Devices/PLCs to connect to the display.
Manufacturer	Select the manufacturer of the External Device to connect. Select "Fuji Electric Co., Ltd.".
Series	Select the External Device model (series) and the connection method. Select "MICREX-SX Series SIO". In System configuration, make sure the External Device you are connecting is supported by "MICREX-SX Series SIO" in system configuration. ☞ "1 System Configuration" (page 3)
Port	Select the Display port to be connected to the External Device.
Use System Area	Check this option to synchronize the system data area of the Display and the device (memory) of the External Device. When synchronized, you can use the External Device's ladder program to switch the display or display the window on the Display. Cf. GP-Pro EX Reference Manual "LS Area (Direct Access Method Area)" This feature can also be set in GP-Pro EX or in the Display's offline mode. Cf. GP-Pro EX Reference Manual "System Settings [Display Unit] - [System Area] Settings Guide" Cf. Maintenance/Troubleshooting Guide "Main Unit - System Area Settings"

### 3 Example of Communication Setting

Examples of communication settings of the Display and the External Device, recommended by Pro-face, are shown.

#### 3.1 Setting Example 1

##### ■ Settings of GP-Pro EX

##### ◆ Communication Settings

To display the setup screen, from the [Project] menu, point to [System Settings] and select [Device/PLC].

##### ◆ Device Setting

To display the [Individual Device Settings] dialog box, from [Device-Specific Settings] in the [Device/PLC] window, select the external device and click [Settings] .

##### ■ Settings of External Device

Communication setting of External Device is fixed, so setting is not necessary.



## 3.2 Setting Example 2

### ■ Settings of GP-Pro EX

#### ◆ Communication Settings

To display the setup screen, from the [Project] menu, point to [System Settings] and select [Device/PLC].

Device/PLC 1

Summary [Change Device/PLC](#)

Manufacturer  Series  Port

Text Data Mode  [Change](#)

Communication Settings

SIO Type  RS232C  RS422/485(2wire)  RS422/485(4wire)

Speed

Data Length  7  8

Parity  NONE  EVEN  ODD

Stop Bit  1  2

Flow Control  NONE  ER(DTR/CTS)  XON/XOFF

Timeout  (sec)

Retry

Wait To Send  (ms)

RI / VCC  RI  VCC

In the case of RS232C, you can select the 9th pin to RI (Input) or VCC (5V Power Supply). If you use the Digital's RS232C Isolation Unit, please select it to VCC.

Device-Specific Settings

Allowable Number of Devices/PLCs  [Add Device](#)

No.	Device Name	Settings	Add Indirect Device
<input type="button" value="1"/>	<input type="text" value="PLC1"/>	<input type="text" value="Connected to FFK120A=OFF"/>	<input type="button" value="Add Indirect Device"/>

#### ◆ Device Setting

To display the [Individual Device Settings] dialog box, from [Device-Specific Settings] in the [Device/PLC] window, select the external device and click [Settings] .

Individual Device Settings

PLC1

Connected to FFK120A

In case of Connected to FFK120A, %I and %Q devices cannot be used.

Variable Data

Use Variable Data

### ■ Settings of External Device

Communication setting of External Device is fixed, so setting is not necessary.

Set the [Mode] switch of the link I/F unit to "1" (loader mode).

### 3.3 Setting Example 3

#### ■ Settings of GP-Pro EX

##### ◆ Communication Settings

To display the setup screen, from the [Project] menu, point to [System Settings] and select [Device/PLC].

Device/PLC 1

Summary [Change Device/PLC](#)

Manufacturer  Series  Port

Text Data Mode  [Change](#)

Communication Settings

SID Type  RS232C  RS422/485(2wire)  RS422/485(4wire)

Speed

Data Length  7  8

Parity  NONE  EVEN  ODD

Stop Bit  1  2

Flow Control  NONE  ER(DTR/CTS)  XON/XOFF

Timeout  (sec)

Retry

Wait To Send  (ms)

RI / VCC  RI  VCC

In the case of RS232C, you can select the 9th pin to RI (Input) or VCC (5V Power Supply). If you use the Digital's RS232C Isolation Unit, please select it to VCC.

Device-Specific Settings

Allowable Number of Devices/PLCs  [Add Device](#)

No.	Device Name	Settings	Add Indirect Device
<input type="button" value="1"/>	<input type="text" value="PLC1"/>	<input type="text" value="Connected to FFK120A=OFF"/>	<input type="button" value="Add Indirect Device"/>

##### ◆ Device Setting

To display the [Individual Device Settings] dialog box, from [Device-Specific Settings] in the [Device/PLC] window, select the external device and click [Settings] .

Individual Device Settings

PLC1

Connected to FFK120A

In case of Connected to FFK120A, %I and %Q devices cannot be used.

Variable Data

Use Variable Data

#### ■ Settings of External Device

Communication setting of External Device is fixed, so setting is not necessary.

Set the [Mode] switch of the link I/F unit to "2" (loader mode).

## 3.4 Setting Example 4

### ■ Settings of GP-Pro EX

#### ◆ Communication Settings

To display the setup screen, from the [Project] menu, point to [System Settings] and select [Device/PLC].

The screenshot shows the 'Device/PLC 1' configuration window. The 'Summary' section includes:
 

- Manufacturer: Fuji Electric Co.,Ltd.
- Series: MICREX-SX Series SIO
- Port: COM1
- Text Data Mode: 1 (Change)

 The 'Communication Settings' section includes:
 

- SIO Type:  RS232C,  RS422/485(2wire),  RS422/485(4wire)
- Speed: 19200
- Data Length:  7,  8
- Parity:  NONE,  EVEN,  ODD
- Stop Bit:  1,  2
- Flow Control:  NONE,  ER(DTR/CTS),  XON/XOFF
- Timeout: 3 (sec)
- Retry: 2
- Wait To Send: 0 (ms)
- RI / VCC:  RI,  VCC

 A note states: 'In the case of RS232C, you can select the 9th pin to RI (Input) or VCC (5V Power Supply). If you use the Digital's RS232C Isolation Unit, please select it to VCC.' A 'Default' button is present.
   
 The 'Device-Specific Settings' section shows:
 

- Allowable Number of Devices/PLCs: 1 (Add Device)
- Table:
 

No.	Device Name	Settings	Add Indirect Device
1	PLC1	Connected to FFK120A=ON	[Add]

#### ◆ Device Setting

To display the [Individual Device Settings] dialog box, from [Device-Specific Settings] in the [Device/PLC] window, select the external device and click [Settings] .

The 'Individual Device Settings' dialog box for PLC1 shows:
 

- Checked checkbox: Connected to FFK120A
- Note: In case of Connected to FFK120A, %I and %Q devices cannot be used.
- Variable Data section:
  - Use Variable Data:
  - Dropdown menu: [ ]
  - Buttons: New, Edit
- Buttons: OK (O), Cancel

## ■ Settings of External Device

Turn ON the DIP switch No.8 "Initialization method" on the rear panel of general-purpose interface module of the External Device. Use the rotary switch for MODE setting. Refer to your External Device manual for details.

### ◆ Settings of Character Configuration Switch

No.	Setup Value	Setup Description
1	OFF	Unused
2	OFF	
3	OFF	
4	ON	Stop bit length = 1
5	OFF	Data bit length = 8
6	ON	Parity bit = Even
7	ON	Parity bit = Enable
8	ON	Switch setting effective

### ◆ Baud Rate Setting Switch

No.	Setup Value	Setup Description
1	OFF	Always set to OFF.
2	OFF	
3	OFF	
4	OFF	
5	OFF	
6	OFF	
7	ON	Baud rate = 19200
8	OFF	Unused

Setup Items	Setup Value	Notes
MODE switch	1	RS-232C 1:1
T-LINK No.	1	Station No. 1
T-LINK Termination Resistance	ON	Termination resistance: ON

## 3.5 Setting Example 5

### ■ Settings of GP-Pro EX

#### ◆ Communication Settings

To display the setup screen, from the [Project] menu, point to [System Settings] and select [Device/PLC].

#### ◆ Device Setting

To display the [Individual Device Settings] dialog box, from [Device-Specific Settings] in the [Device/PLC] window, select the external device and click [Settings] .

## ■ Settings of External Device

Turn ON the DIP switch No.8 "Initialization method" on the rear panel of general-purpose interface module of the External Device. Use the rotary switch for MODE setting. Refer to your External Device manual for details.

### ◆ Settings of Character Configuration Switch

No.	Setup Value	Setup Description
1	OFF	Unused
2	OFF	
3	OFF	
4	ON	Stop bit length = 1
5	OFF	Data bit length = 8
6	ON	Parity bit = Even
7	ON	Parity bit = Enable
8	ON	Switch setting effective

### ◆ Baud Rate Setting Switch

No.	Setup Value	Setup Description
1	OFF	Always set to OFF.
2	OFF	
3	OFF	
4	OFF	
5	OFF	
6	OFF	
7	ON	Baud rate = 19200
8	OFF	Unused

Setup Items	Setup Value	Notes
MODE switch	3	RS-485 1:N
T-LINK No.	1	Station No. 1
T-LINK Termination Resistance	ON	Termination resistance: ON
RS-485 No.	0	Station No. 0
RS-485 Termination Resistance	ON	Termination resistance: ON

## 4 Setup Items

Set communication settings of the Display with GP-Pro EX or in offline mode of the Display.

The setting of each parameter must be identical to that of External Device.

 "3 Example of Communication Setting" (page 8)

### 4.1 Setup Items in GP-Pro EX

#### ■ Communication Settings

To display the setup screen, from the [Project] menu, point to [System Settings] and select [Device/PLC].

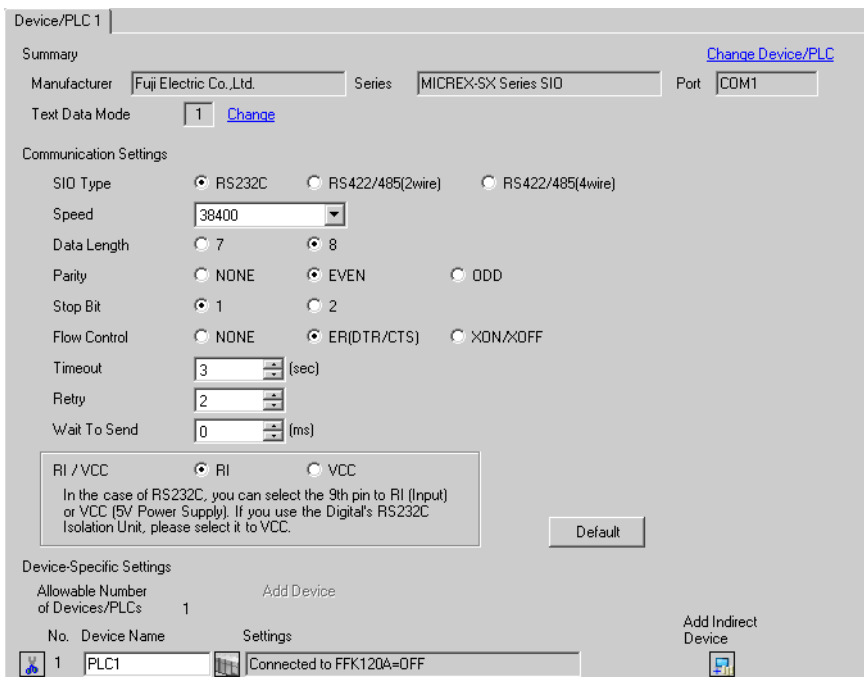

Setup Items	Setup Description
SIO Type	Select the SIO type to communicate with the External Device.
Speed	Select speed between the External Device and the Display.
Data Length	Select data length.
Parity	Select how to check parity.
Stop Bit	Select stop bit length.
Flow Control	Select the communication control method to prevent overflow of transmission and reception data.
Timeout	Use an integer from 1 to 127 to enter the time (s) for which the Display waits for the response from the External Device.
Retry	In case of no response from the External Device, use an integer from 0 to 255 to enter how many times the Display retransmits the command.
Wait To Send	Use an integer from 0 to 255 to enter standby time (ms) for the Display from receiving packets to transmitting next commands.

Setup Items	Setup Description
RI/VCC	You can switch RI/VCC of the 9th pin when you select RS232C for SIO type. It is necessary to change RI/5V by changeover switch of IPC when connect with IPC. Please refer to the manual of the IPC for more detail.

**NOTE**

- Refer to the GP-Pro EX Reference Manual for Indirect Device.

Cf. GP-Pro EX Reference Manual "Changing the Device/PLC at Runtime (Indirect Device)"

### ■ Device Setting

To display the [Individual Device Settings] dialog box, from [Device-Specific Settings] in the [Device/PLC] window, select the external device and click [Settings] .

Set [Individual Device Settings] when using variable data.

 "6.4 When Using a Variable" (page 47)

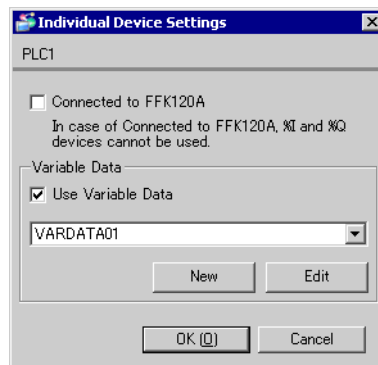

Setup Items	Setup Description
Connected to FFK120A	Put a check in the box when connecting FFK120A.
Use Variable Data	Put a check in the box when using variable data.
Variable Data	Select variable data.



## 4.2 Setup Items in Offline Mode

**NOTE**

- Refer to the Maintenance/Troubleshooting Guide for information on how to enter offline mode or about the operation.

Cf. Maintenance/Troubleshooting Guide "Offline Mode"

- The number of the setup items to be displayed for 1 page in the offline mode depends on the Display in use. Please refer to the Reference manual for details.

### ■ Communication Settings

To display the setting screen, touch [Device/PLC Settings] from [Peripheral Settings] in offline mode. Touch the External Device you want to set from the displayed list.

Comm.	Device	Option		
MICREX-SX Series SIO			[COM1]	Page 1/1
SIO Type		RS232C		
Speed		38400		
Data Length		<input type="radio"/> 7 <input checked="" type="radio"/> 8		
Parity		<input type="radio"/> NONE <input checked="" type="radio"/> EVEN <input type="radio"/> ODD		
Stop Bit		<input checked="" type="radio"/> 1 <input type="radio"/> 2		
Flow Control		ER(DTR/CTS)		
Timeout(s)		3		
Retry		2		
Wait To Send(ms)		0		
	Exit		Back	2012/01/19 21:23:55

Setup Items	Setup Description
SIO Type	Select the SIO type to communicate with the External Device. <b>IMPORTANT</b> To make the communication settings correctly, confirm the serial interface specifications of Display unit for [SIO Type]. We cannot guarantee the operation if a communication type that the serial interface does not support is specified. For details concerning the serial interface specifications, refer to the manual for Display unit.
Speed	Select speed between the External Device and the Display.
Data Length	Select data length.
Parity	Select how to check parity.
Stop Bit	Select stop bit length.
Flow Control	Select the communication control method to prevent overflow of transmission and reception data.

Setup Items	Setup Description
Timeout	Use an integer from 1 to 127 to enter the time (s) for which the Display waits for the response from the External Device.
Retry	In case of no response from the External Device, use an integer from 0 to 255 to enter how many times the Display retransmits the command.
Wait To Send	Use an integer from 0 to 255 to enter standby time (ms) for the Display from receiving packets to transmitting next commands.

## ■ Device Setting

To display the setting screen, touch [Device/PLC Settings] from [Peripheral Settings]. Touch the External Device you want to set from the displayed list, and touch [Device].

Comm.	Device	Option		
MICREX-SX Series SIO		[COM1]	Page 1/1	
Device/PLC Name		[PLC1]		
Connected to FFK120A		OFF		
Exit		Back		2012/01/19 21:24:01

Setup Items	Setup Description
Device/PLC Name	Select the External Device for device setting. Device name is a title of External Device set with GP-Pro EX.(Initial value [PLC1])
Connected to FFK120A	Displays the connection state with FFK120A.

## ■ Option

To display the setting screen, touch [Device/PLC Settings] from [Peripheral Equipment Settings]. Touch the External Device you want to set from the displayed list, and touch [Option].

Comm.	Device	Option		
MICREX-SX Series SIO		[COM1]	Page 1/1	
RI / VCC                      ● RI                      ● VCC In the case of RS232C, you can select the 9th pin to RI(Input) or VCC(5V Power Supply). If you use the Digital's RS232C Isolation Unit, please select it to VCC.				
	Exit		Back	2012/01/19 21:24:05

Setup Items	Setup Description
RI/VCC	Switches RI/VCC of the 9th pin. It is necessary to change RI/5V by changeover switch of IPC when connect with IPC. Please refer to the manual of the IPC for more detail.

### NOTE

- GP-4100 series, GP-4\*01TM and GP-Rear Module do not have the [Option] setting in the offline mode.

## 5 Cable Diagram

The cable diagram shown below may be different from the cable diagram recommended by Fuji Electric Co., Ltd.. Please be assured there is no operational problem in applying the cable diagram shown in this manual.

- The FG pin of the External Device body must be D-class grounded. Please refer to the manual of the External Device for more details.
- SG and FG are connected inside the Display. When connecting SG to the External Device, design the system not to form short-circuit loop.
- Connect the isolation unit, when communication is not stabilized under the influence of a noise etc.

Cable Diagram 1

Display (Connection Port)	Cable		Notes
GP3000 (COM1) GP4000* <sup>1</sup> (COM1) SP5000* <sup>2</sup> (COM1/2) SP-5B00 (COM1) ST3000 (COM1) ST6000 (COM1) STM6000 (COM1) STC6000 (COM1) ET6000 (COM1) LT3000 (COM1) IPC* <sup>3</sup> PC/AT	1A	Connection adapter by Fuji Electric Co., Ltd. NW0H-CNV + Connection cable by Fuji Electric Co., Ltd.* <sup>4</sup> NP4H-CB2 (2m)	
GP-4105 (COM1) GP-4115T (COM1) GP-4115T3 (COM1)	1B	User-created cable + Connection adapter by Fuji Electric Co., Ltd. NW0H-CNV + Connection cable by Fuji Electric Co., Ltd.* <sup>4</sup> NP4H-CB2 (2m)	

\*1 All GP4000 models except GP-4100 Series and GP-4203T

\*2 Except SP-5B00

\*3 Only the COM port which can communicate by RS-232C can be used.  
☞ "■ IPC COM Port" (page 4)

\*4 CPU versions that support NP4H-CB2 are as follows:  
SPH200  
NP1PH-08 / NP1PH-16: lower than V22  
SPH300  
NP1PS-32: lower than V22  
NP1PS-32R / NP1PS-74R / NP1PS-117R: lower than V26  
NP1PS-74 / NP1PS-117: All versions  
SPH2000  
NP1PM-48E: lower than V25

1A)

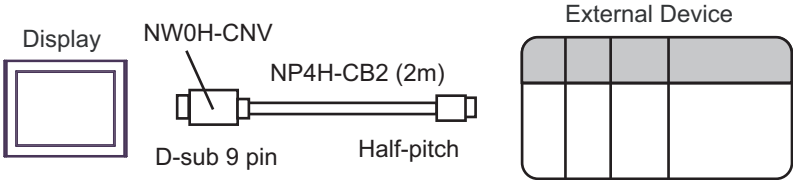

1B)

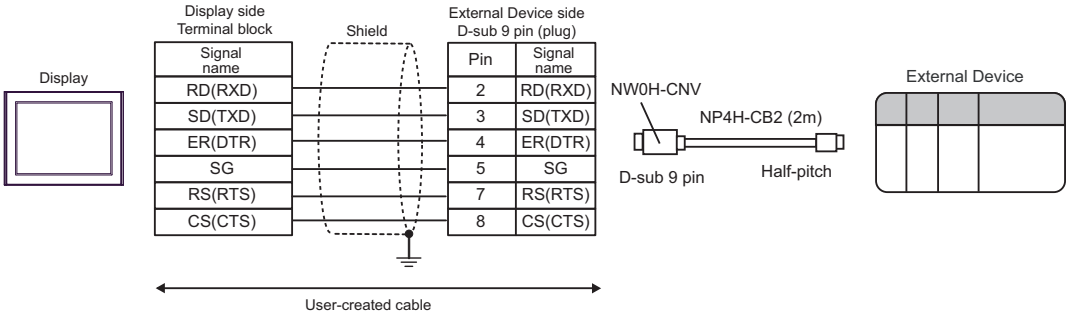

Cable Diagram 2

Display (Connection Port)	Cable		Notes
GP3000 (COM1) GP4000* <sup>1</sup> (COM1) SP5000* <sup>2</sup> (COM1/2) SP-5B00 (COM1) ST3000 (COM1) ST6000 (COM1) STM6000 (COM1) STC6000 (COM1) ET6000 (COM1) LT3000 (COM1) IPC* <sup>3</sup> PC/AT	2A	User-created cable	The cable length must be 15m or less.
GP-4105 (COM1) GP-4115T (COM1) GP-4115T3 (COM1)	2B	User-created cable	The cable length must be 15m or less.

- \*1 All GP4000 models except GP-4100 Series and GP-4203T
- \*2 Except SP-5B00
- \*3 Only the COM port which can communicate by RS-232C can be used.  
 "■ IPC COM Port" (page 4)

2A)

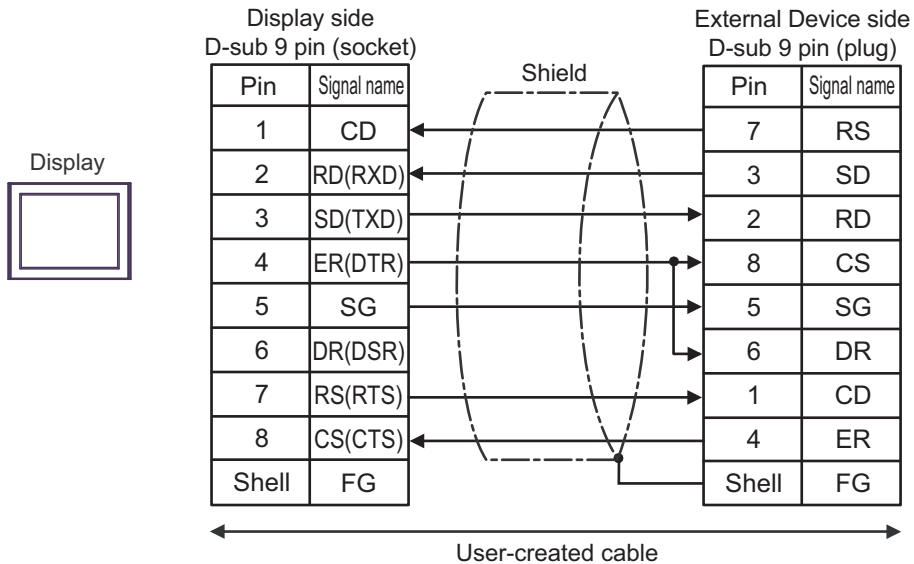

2B)

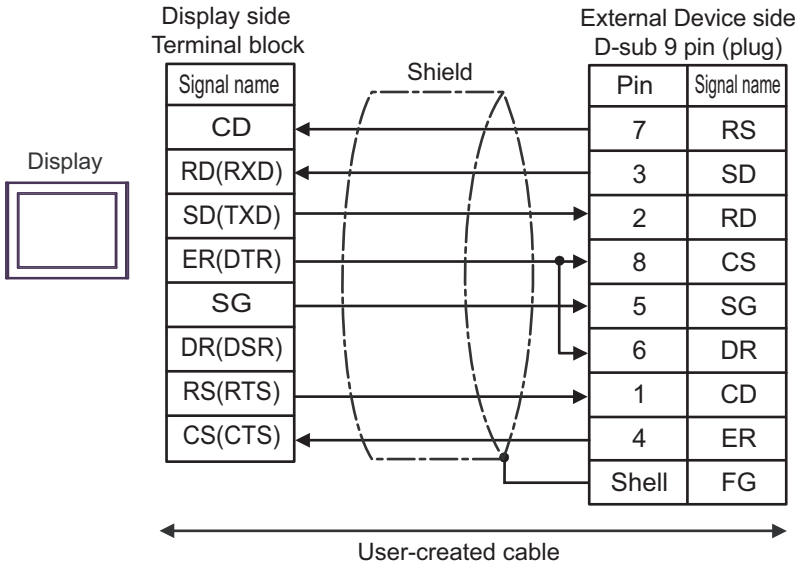

Cable Diagram 3

Display (Connection Port)	Cable		Notes
GP3000 <sup>*1</sup> (COM1) AGP-3302B (COM2) GP-4*01TM (COM1) GP-Rear Module (COM1) ST3000 <sup>*2</sup> (COM2) LT3000 (COM1) IPC <sup>*3</sup>	3A	COM port conversion adapter by Pro-face CA3-ADPCOM-01 + Terminal block conversion adapter by Pro-face CA3-ADPTRM-01 + User-created cable	The cable length must be 1000m or less.  Termination resistance switch on the communication module should be set "3".
	3B	User-created cable	
GP3000 <sup>*4</sup> (COM2)	3C	Online adapter by Pro-face CA4-ADPONL-01 + Terminal block conversion adapter by Pro-face CA3-ADPTRM-01 + User-created cable	The cable length must be 1000m or less.  Termination resistance switch on the communication module should be set "3".
	3D	Online adapter by Pro-face CA4-ADPONL-01 + User-created cable	
GP-4106 (COM1) GP-4116T (COM1)	3E	User-created cable	The cable length must be 1000m or less.  Termination resistance switch on the communication module should be set "3".
GP4000 <sup>*5</sup> (COM2) GP-4201T (COM1) SP5000 <sup>*6</sup> (COM1/2) SP-5B00 (COM2) ST6000 <sup>*7</sup> (COM2) ST-6200 (COM1) STM6000 (COM1) STC6000 (COM1) ET6000 <sup>*8</sup> (COM2) PS6000 (Basic Box) (COM1/2)	3F	RS-422 Terminal Block Conversion Adapter by Pro-face PFXZCBADTM1 <sup>*9</sup> + User-created cable	The cable length must be 1000m or less.  Termination resistance switch on the communication module should be set "3".
	3B	User-created cable	
PE-4000B <sup>*10</sup> PS5000 <sup>*10</sup> PS6000 (Optional Interface) <sup>*10</sup>	3G	User-created cable	The cable length must be 1000m or less.  Termination resistance switch on the communication module should be set "3".

\*1 All GP3000 models except AGP-3302B

\*2 Except AST-3211A and AST-3302B



- \*3 Only the COM port which can communicate by RS-422/485 (4 wire) can be used. (Except PE-4000B, PS5000, and PS6000)  
☞ "■ IPC COM Port" (page 4)
- \*4 All GP3000 models except GP-3200 series and AGP-3302B
- \*5 All GP4000 models except GP-4100 Series, GP-4\*01TM, GP-Rear Module, GP-4201T and GP-4\*03T
- \*6 Except SP-5B00
- \*7 Except ST-6200
- \*8 Due to the COM port specifications, flow control is not possible. Omit wiring the control pins on the Display side of the cable diagram.
- \*9 When using a Terminal Block Conversion Adapter (CA3-ADPTRM-01) instead of the RS-422 Terminal Block Conversion Adapter, refer to Cable Diagram 3A.
- \*10 Only the COM port which can communicate by RS-422/485 (4 wire) can be used.  
☞ "■ IPC COM Port" (page 4)

3A)

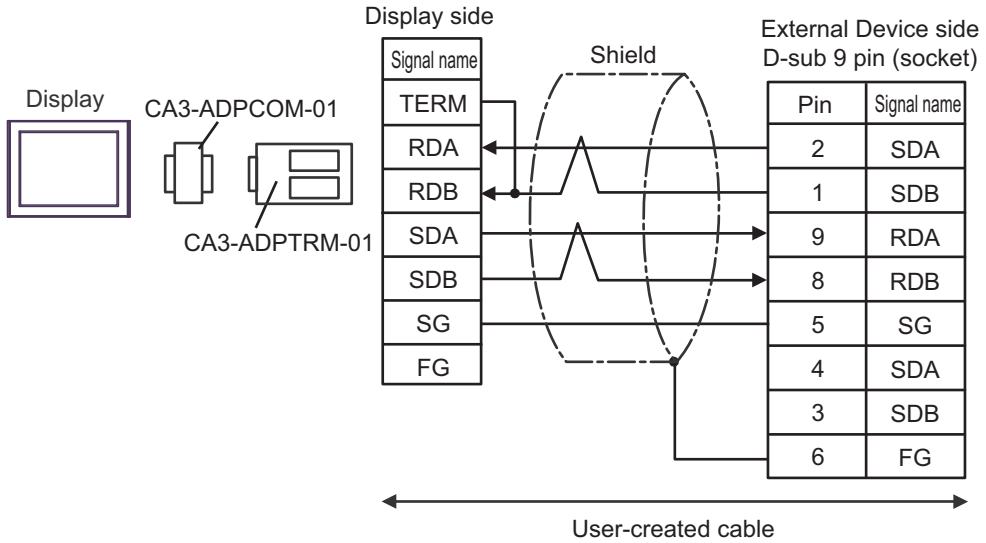

\* Termination resistance switch on the communication module should be set "3".

3B)

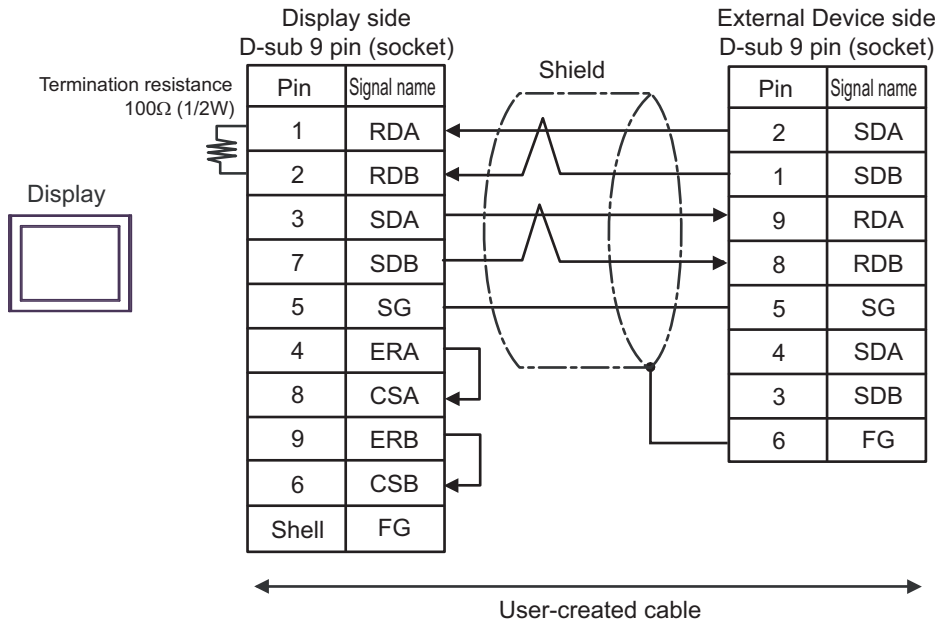

\* Termination resistance switch on the communication module should be set "3".

3C)

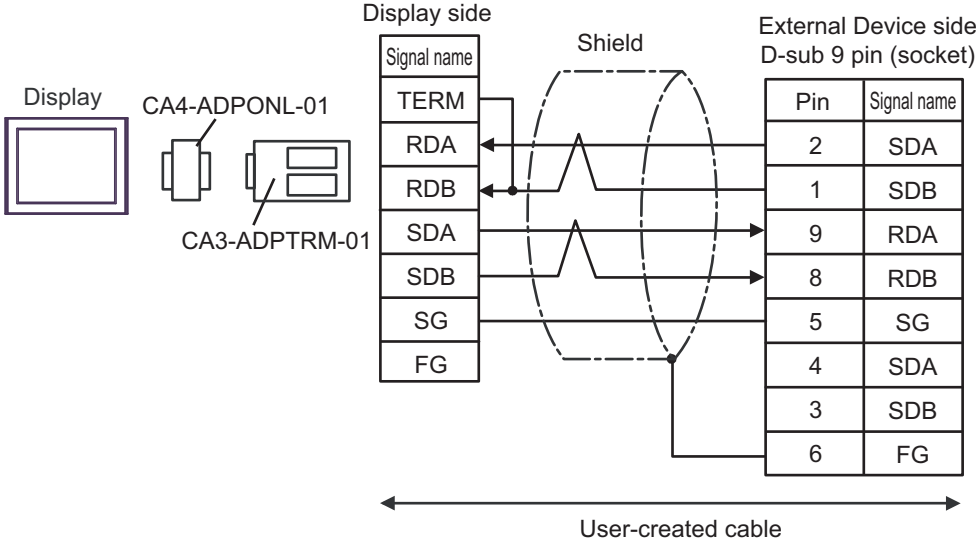

\* Termination resistance switch on the communication module should be set "3".

3D)

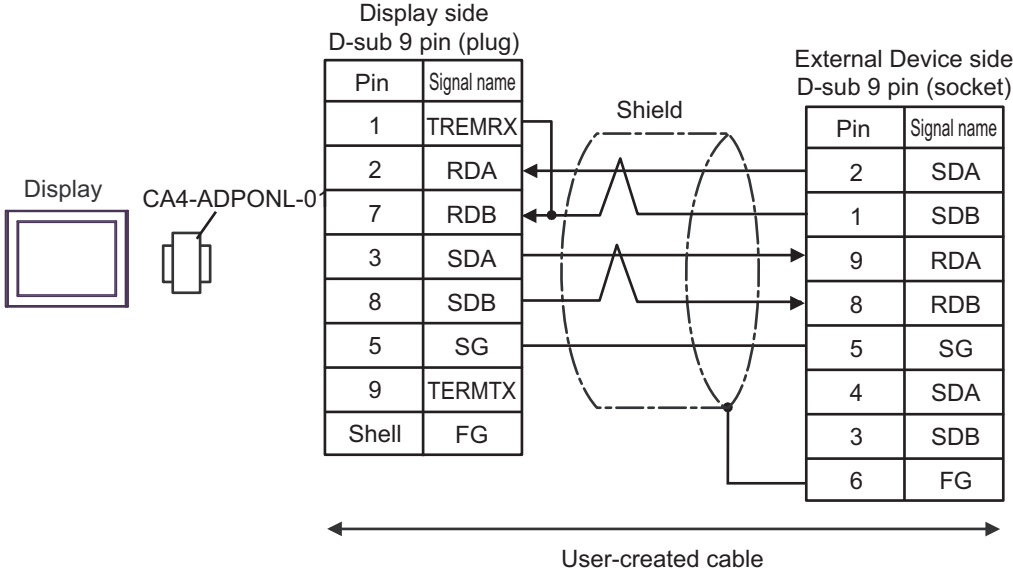

\* Termination resistance switch on the communication module should be set "3".

3E)

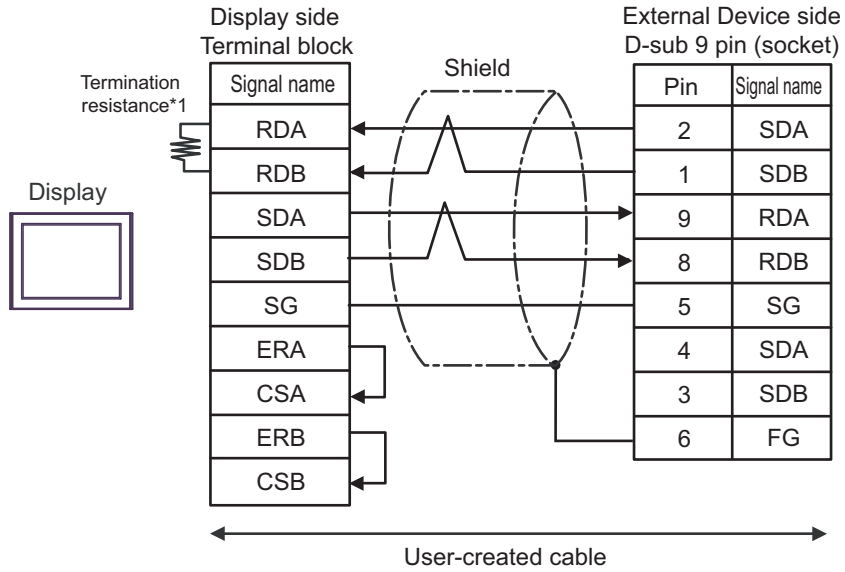

\* Termination resistance switch on the communication module should be set "3".

\*1 The resistance in the Display is used as the termination resistance. Set the value of the DIP Switch on the rear of the Display as shown in the table below.

DIP Switch No.	Set Value
1	OFF
2	OFF
3	ON
4	ON

3F)

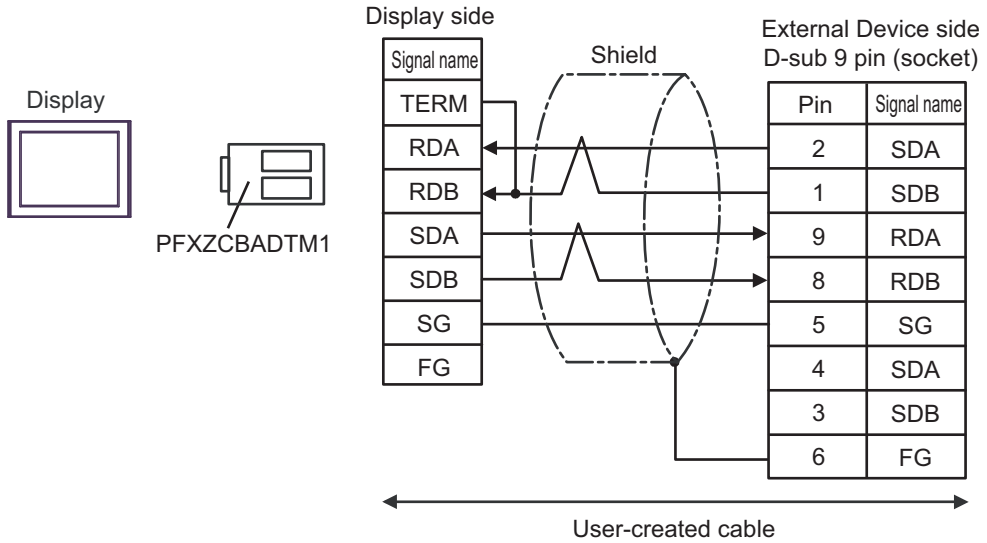

\* Termination resistance switch on the communication module should be set "3".

3G)

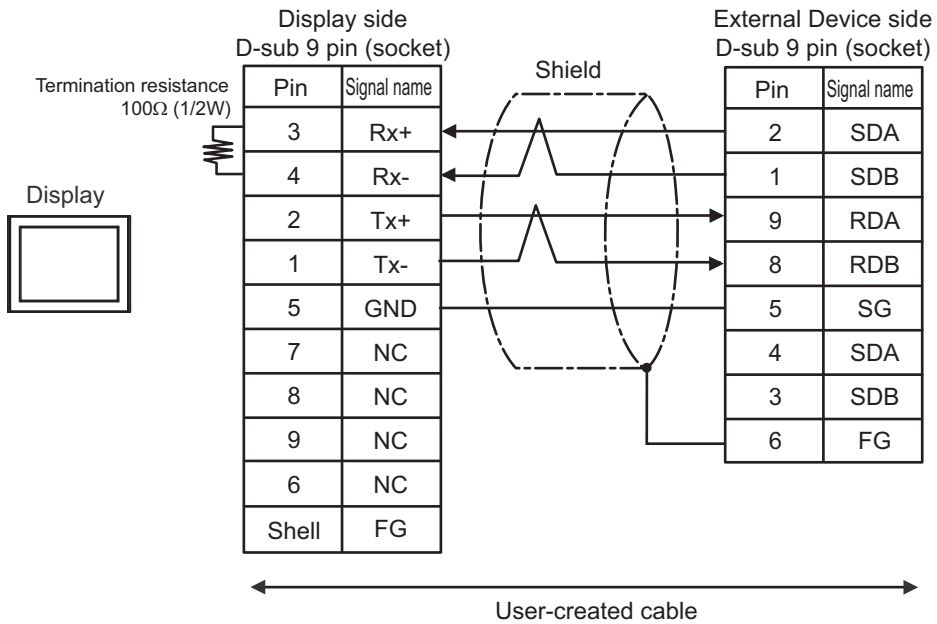

\* Termination resistance switch on the communication module should be set "3".

Cable Diagram 4

Display (Connection Port)	Cable		Notes
GP3000 (COM1) GP4000* <sup>1</sup> (COM1) SP5000* <sup>2</sup> (COM1/2) SP-5B00 (COM1)	4A	RS232C cable by Pro-face CA3-CBL232/5M-01 (5m)	Set the operation mode on the interface to 1.
ST3000 (COM1) ST6000 (COM1) STM6000 (COM1) STC6000 (COM1) ET6000 (COM1) LT3000 (COM1) IPC* <sup>3</sup> PC/AT	4B	User-created cable	
GP-4105 (COM1) GP-4115T (COM1) GP-4115T3 (COM1)	4C	User-created cable	Set the operation mode on the interface to 1.

\*1 All GP4000 models except GP-4100 Series and GP-4203T

\*2 Except SP-5B00

\*3 Only the COM port which can communicate by RS-232C can be used.  
"■ IPC COM Port" (page 4)

4A)



\* Set the operation mode on the External Device interface to 1.

4B)

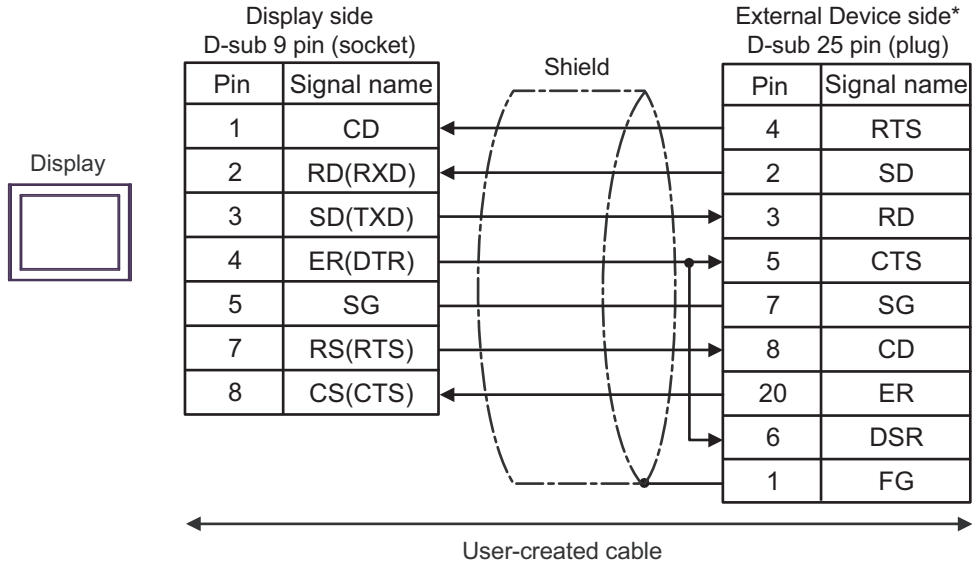

\* Set the operation mode on the External Device interface to 1.

4C)

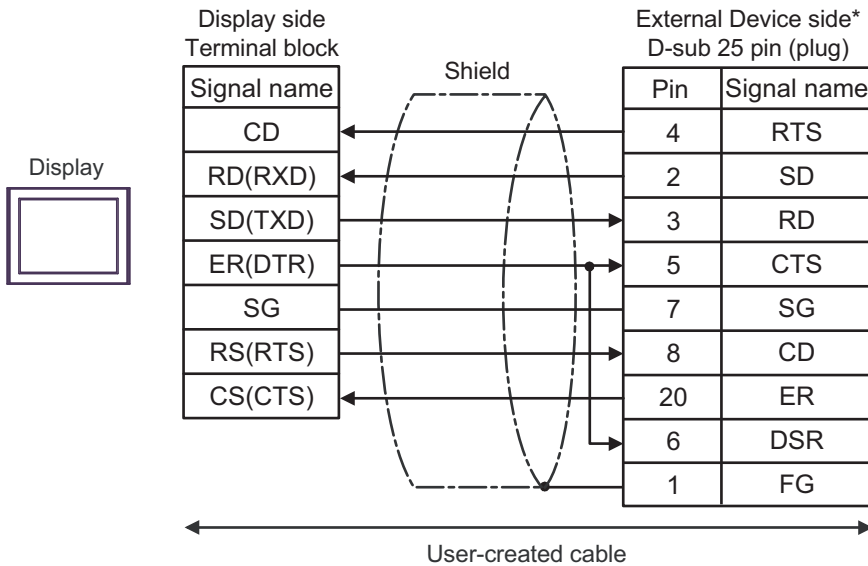

\* Set the operation mode on the External Device interface to 1.

Cable Diagram 5

Display (Connection Port)	Cable		Notes
GP3000* <sup>1</sup> (COM1) AGP-3302B (COM2) GP-4*01TM (COM1) GP-Rear Module (COM1) ST3000* <sup>2</sup> (COM2) LT3000 (COM1) IPC* <sup>3</sup>	5A	RS422 cable by Pro-face CA3-CBL422/5M-01 (5m)	Turn ON the termination resistance switch on the External Device.  Set the operation MODE to 3.
	5B	COM port conversion adapter by Pro-face CA3-ADPCOM-01 + Terminal block conversion adapter by Pro-face CA3-ADPTRM-01 + User-created cable	
	5C	COM port conversion adapter by Pro-face CA3-ADPCOM-01 + 422 cable for GP by Pro-face CA3-CBL422-01 (5m)	
	5D	User-created cable	
GP3000* <sup>4</sup> (COM2)	5E	Online adapter by Pro-face CA4-ADPONL-01 + Terminal block conversion adapter by Pro-face CA3-ADPTRM-01 + User-created cable	Turn ON the termination resistance switch on the External Device.  Set the operation MODE to 3.
	5F	Online adapter by Pro-face CA4-ADPONL-01 + 422 cable by Pro-face CA3-CBL422-01 (5m)	
	5G	Online adapter by Pro-face CA4-ADPONL-01 + User-created cable	
GP-4106 (COM1) GP-4116T (COM1)	5H	User-created cable	Turn ON the termination resistance switch on the External Device.  Set the operation MODE to 3.



Display (Connection Port)	Cable		Notes
GP4000* <sup>5</sup> (COM2) GP-4201T (COM1) SP5000* <sup>6</sup> (COM1/2) SP-5B00 (COM2) ST6000* <sup>7</sup> (COM2) ST-6200 (COM1) STM6000 (COM1) STC6000 (COM1) ET6000* <sup>8</sup> (COM2) PS6000 (Basic Box) (COM1/2)	5I	RS-422 Terminal Block Conversion Adapter by Pro-face PFXZCBADTM1* <sup>9</sup> + User-created cable	Turn ON the termination resistance switch on the External Device.  Set the operation MODE to 3.
	5A	RS422 cable by Pro-face CA3-CBL422/5M-01 (5m)	
	5C	COM port conversion adapter by Pro-face CA3-ADPCOM-01 + 422 cable for GP by Pro-face CA3-CBL422-01 (5m)	
	5D	User-created cable	
PE-4000B* <sup>10</sup> PS5000* <sup>10</sup> PS6000 (Optional Interface)* <sup>10</sup>	5J	User-created cable	Turn ON the termination resistance switch on the External Device.  Set the operation MODE to 3.

\*1 All GP3000 models except AGP-3302B

\*2 Except AST-3211A and AST-3302B

\*3 Only the COM port which can communicate by RS-422/485 (4 wire) can be used. (Except PE-4000B, PS5000, and PS6000)

"■ IPC COM Port" (page 4)

\*4 All GP3000 models except GP-3200 series and AGP-3302B

\*5 All GP4000 models except GP-4100 Series, GP-4\*01TM, GP-Rear Module, GP-4201T and GP-4\*03T

\*6 Except SP-5B00

\*7 Except ST-6200

\*8 Due to the COM port specifications, flow control is not possible. Omit wiring the control pins on the Display side of the cable diagram.

\*9 When using a Terminal Block Conversion Adapter (CA3-ADPTRM-01) instead of the RS-422 Terminal Block Conversion Adapter, refer to Cable Diagram 5B.

\*10 Only the COM port which can communicate by RS-422/485 (4 wire) can be used.

"■ IPC COM Port" (page 4)

5A)

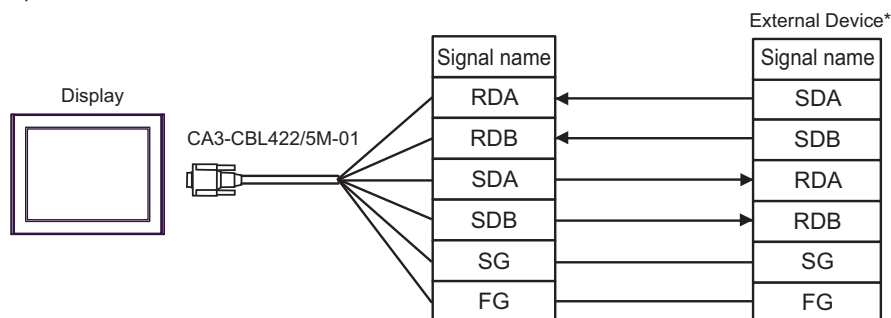

\* Turn On the termination resistance switch of the External Device, and set the operation mode to 3.

5B)

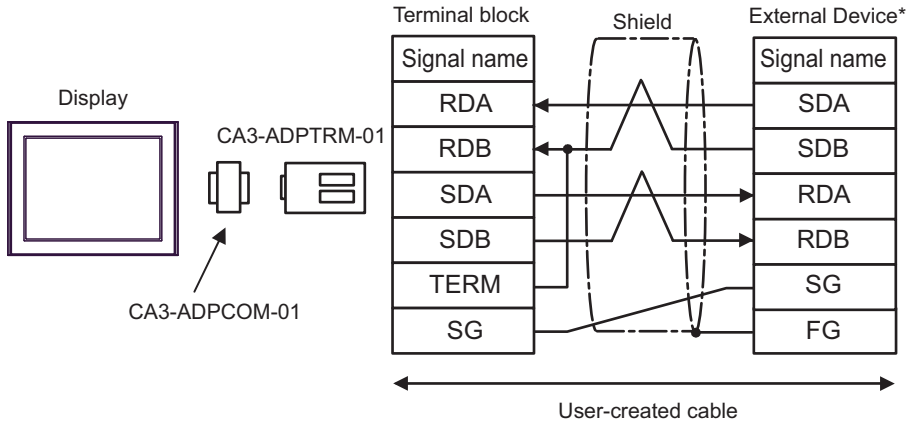

\* Turn On the termination resistance switch of the External Device, and set the operation mode to 3.

5C)

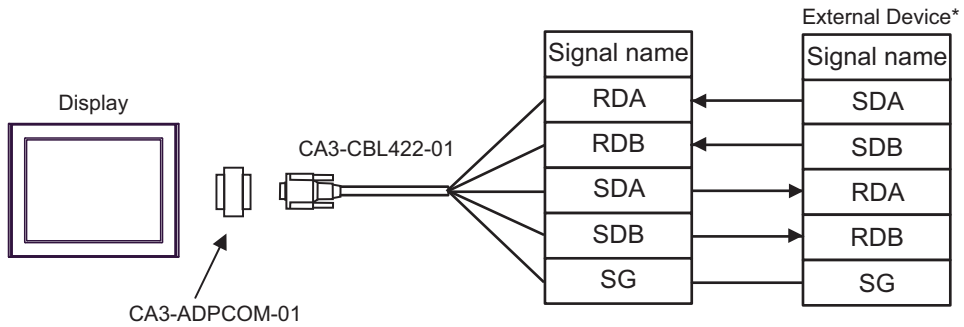

Do not connect the FG terminal of CA3-CBL422-01 to the External Device.

\* Turn On the termination resistance switch of the External Device, and set the operation mode to 3.

5D)

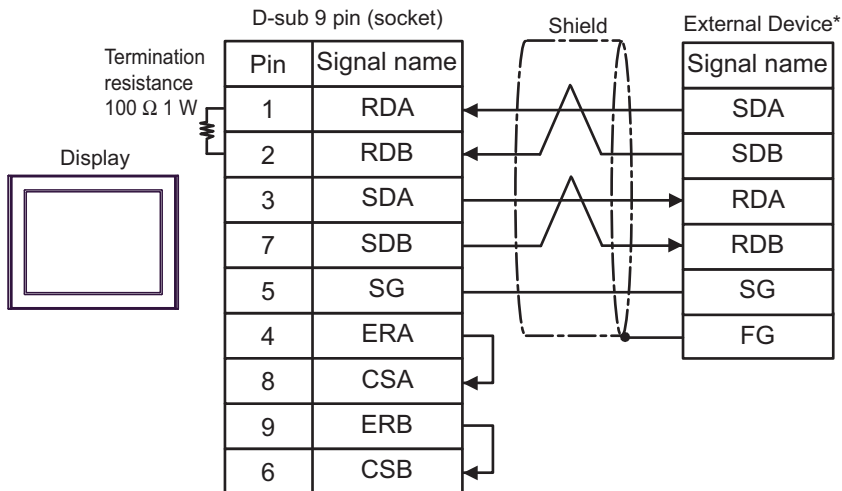

\* Turn On the termination resistance switch of the External Device, and set the operation mode to 3.

5E)

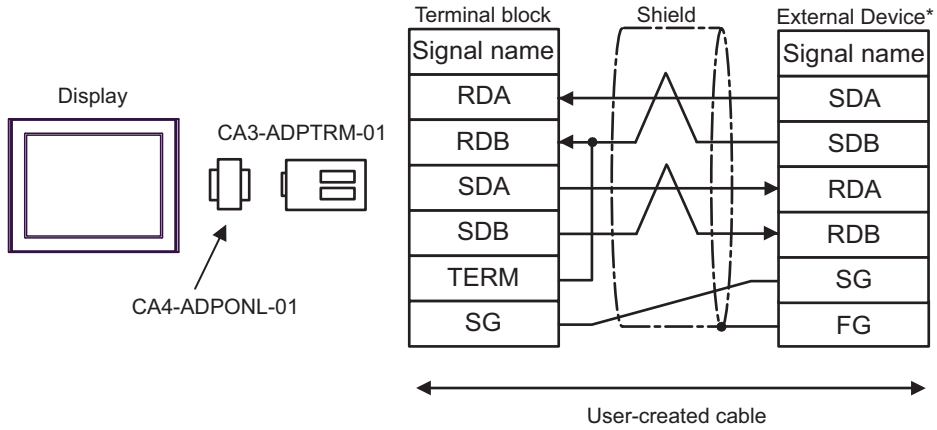

\* Turn On the termination resistance switch of the External Device, and set the operation mode to 3.

5F)

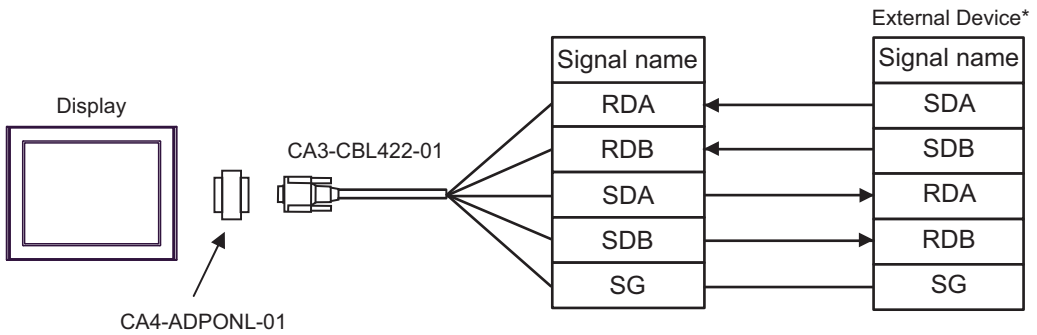

Do not connect the FG terminal of CA3-CBL422-01 to the External Device.

\* Turn On the termination resistance switch of the External Device, and set the operation mode to 3.

5G)

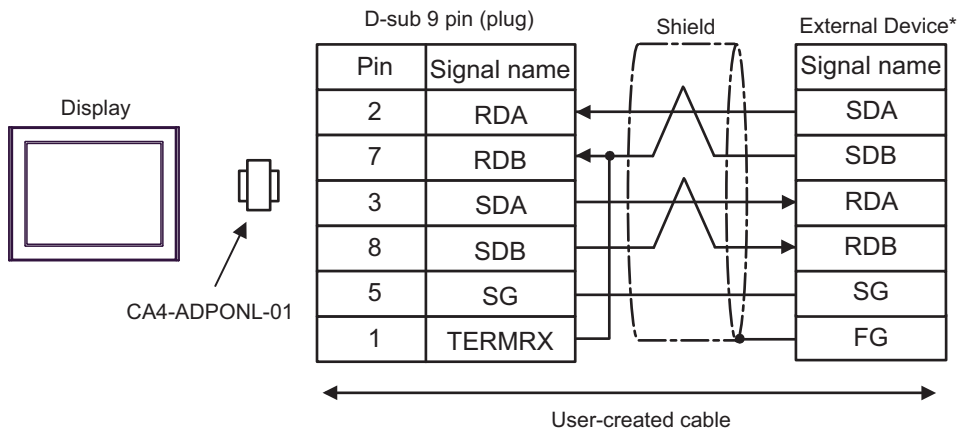

\* Turn On the termination resistance switch of the External Device, and set the operation mode to 3.

5H)

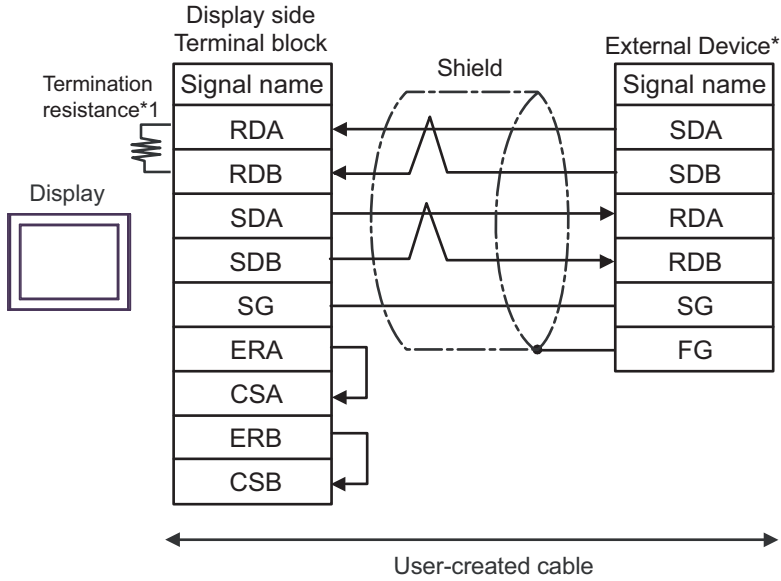

\* Turn On the termination resistance switch of the External Device, and set the operation mode to 3.

\*1 The resistance in the Display is used as the termination resistance. Set the value of the DIP Switch on the rear of the Display as shown in the table below.

DIP Switch No.	Set Value
1	OFF
2	OFF
3	ON
4	ON

5I)

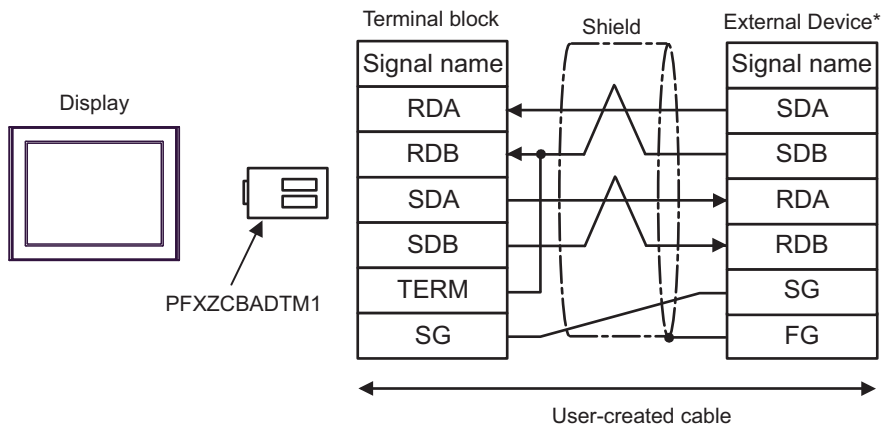

\* Turn On the termination resistance switch of the External Device, and set the operation mode to 3.

5J)

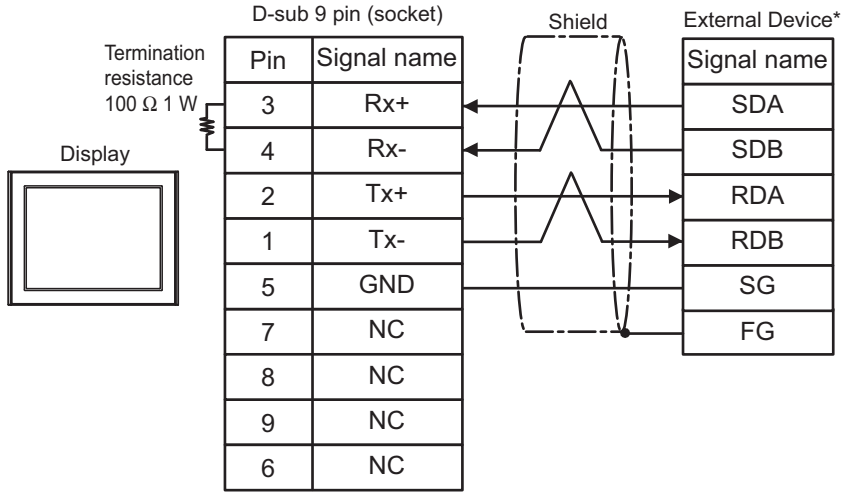

\* Turn On the termination resistance switch of the External Device, and set the operation mode to 3.

## 6 Supported Device

Range of supported device address is shown in the table below. Please note that the actually supported range of the devices varies depending on the External Device to be used. Please check the actual range in the manual of your External Device.

Enter the External Device address in the dialog below.

### NOTE

- When the communication unit and the Input/Output unit are used at the same time, Input/Output Memory cannot be used.

For address settings in GP-Pro EX, use Standard Memory and synchronize the Standard Memory address with Input/Output Memory address in External Device.

### ■ When [Addressing Mode] is "Direct"

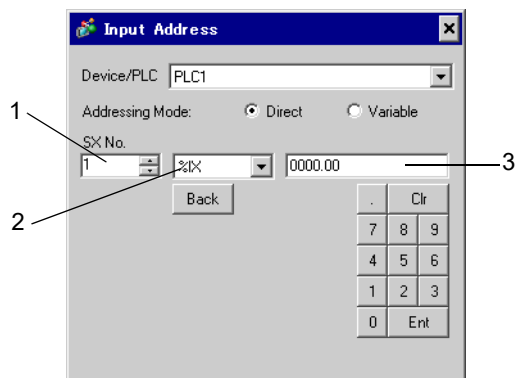

- 1 Enter [SX No.] (Input/Output Memory) or [CPU NO.] (Standard/Retain/System Memory).
- 2 Select a device.
- 3 Enter the address.

## ■ When [Addressing Mode] is "Variable"

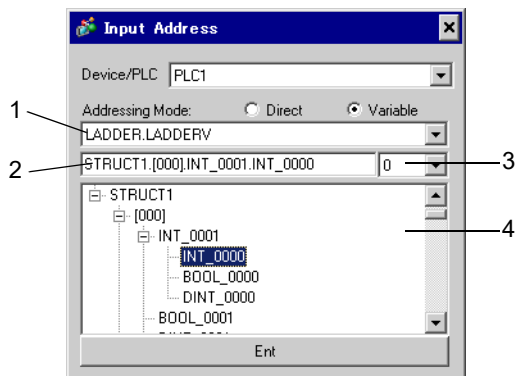

- 1 Select a worksheet.
  - 2 Enter the address.
  - 3 When inputting a bit address, select the bit position of bit address.
  - 4 Variable data is displayed. The address can be entered by double-clicking the displayed variable.
- ☞ " ■ Making New Variable Data" (page 52)

### NOTE

- The variables where derived data type of 3 or more hierarchies are defined will not be displayed.

## ■ Ladder Software

There are SX-Programmer Expert (D300win) and SX-Programmer Standard in the ladder software to be used for setting the External Device. The device name differs respectively as follows.

Device Name		SX-Programmer Expert (D300win)	SX-Programmer Standard
I/O Memory	Input	%I	X
	Output	%Q	Y
Standard Memory (fast)		%MW1.0 - %MW1.2047	WM0 - WM2047
Standard Memory <sup>*1</sup>		%MW1.2048 - %MW1.262143	WM2048 - WM262143
Retain Memory <sup>*1</sup>		%MW3.0 - %MW3.260095	WL0 - WL260095
System Memory		%MW10.0 - %MW10.511	WSM0 - WSM511

\*1 The number of device items can be increased or decreased by the ladder tool. This table shows the number of default items.



## 6.1 SPH200

**▬▬▬** This address can be specified as system data area.

Device	Bit Address	Word Address	32bits	Remarks
Input Memory	%IX□.0000.00 - %IX□.0511.15	%IW□.0000 - %IW□.0511	<b>[L/H]</b>	*1 *2
Output Memory	%QX□.0000.00 - %QX□.0511.15	%QW□.0000 - %QW□.0511		*1 *2
Standard Memory	%MX□.1.0000000.00 - %MX□.1.0008191.15	%MW□.1.0000000 - %MW□.1.0008191		*3 *4 *5
Retain Memory	%MX□.3.000000.00 - %MX□.3.004095.15	%MW□.3.000000 - %MW□.3.004095		*3 *4 *5
System Memory	%MX□.10.000000.00 - %MX□.10.008191.15	%MW□.10.000000 - %MW□.10.008191		*3 *5

\*1 Input/Output Memory Address Designation is as shown below.

• Bit Designation

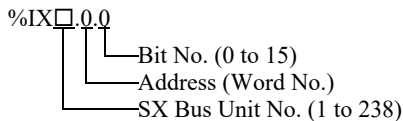

• Word Designation

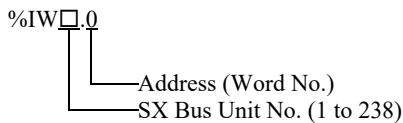

**NOTE**

- Please refer to the SX Bus Unit No. details in the manual of External Device.

\*2 In Case of “Connected to FFK120A”, This device is not supported.

\*3 Standard/Retain/System Memory Address Designation is as shown below.

• Bit Designation

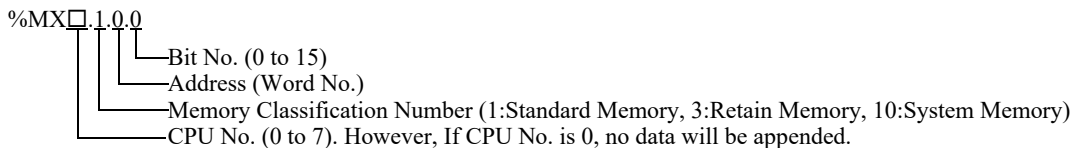

• Word Designation

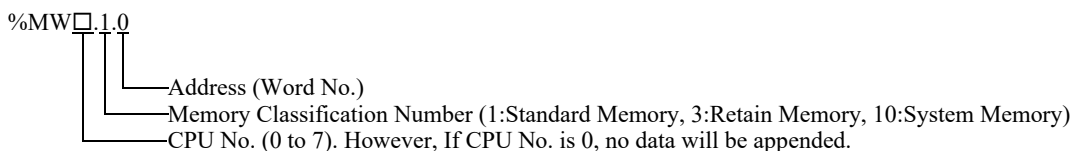

\*4 Standard and Retain Memory sizes can be changed. However, the total memory size is fixed. (For details, refer to the manual of External Device).

- \*5 In Case of "Connected to FFK120A",  
When you write the bit address, the Display reads the word address corresponding to that of the External Device first. Then, it changes the target bit address among the word data once read and returns the word data to the External Device. Note that the correct data may not be written if you change the word address value in the ladder program while the Display reads the data of the External Device and returns it to the External Device.

**NOTE**

- When specifying the address of the External Device directly, always use a setting within the specified AT range of the ladder software. We recommend using an AT-specified- variable for the External Device used on the Display. Please refer to the Micrex-SX Series D300Win <Reference> Users Manual by Fuji Electric Co., Ltd. for details of specifying the AT range and how to set it. When using a variable that is not AT-specified, variable needs to be imported again and screen transfer needs to be executed if ladder program or variable is changed.
- Always use a system area and reading area within the specified AT range.
- Use high performance CPU system area with an address of %MW1.2048 or later.
- Please refer to the GP-Pro EX Reference Manual for system data area.  
Cf. GP-Pro EX Reference Manual "LS Area (Direct Access Method Area)"
- Please refer to the precautions on manual notation for icons in the table.  
 "Manual Symbols and Terminology"

## 6.2 SPH300

**▬▬▬** This address can be specified as system data area.

Device	Bit Address	Word Address	32bits	Remarks
Input Memory	%IX□.0000.00 - %IX□.0511.15	%IW□.0000 - %IW□.0511	<b>[L/H]</b>	*1 *2
Output Memory	%QX□.0000.00 - %QX□.0511.15	%QW□.0000 - %QW□.0511		*1 *2
Standard Memory	%MX□.1.0000000.00 - %MX□.1.0262143.15	%MW□.1.0000000 - %MW□.1.0262143		*3 *4 *5
Retain Memory	%MX□.3.000000.00 - %MX□.3.130047.15	%MW□.3.000000 - %MW□.3.130047		*3 *4 *5
System Memory	%MX□.10.000000.00 - %MX□.10.065535.15	%MW□.10.000000 - %MW□.10.065535		*3 *5

\*1 Input/Output memory Address Designation is as shown below.

- Bit Designation

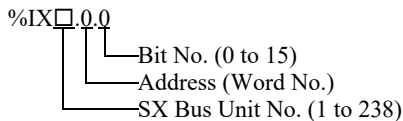

- Word Designation

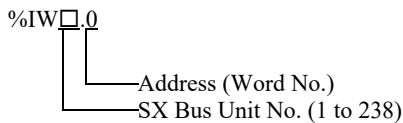
**NOTE**

Please refer to the SX Bus Unit No. details in the manual of External Device.

\*2 In Case of “Connected to FFK120A”, This device is not supported.

\*3 Standard/Retain/System Memory Address Designation is as shown below.

- Bit Designation

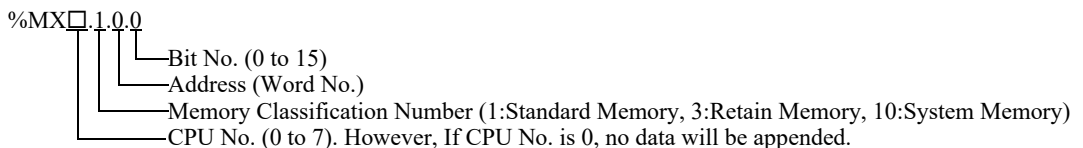

- Word Designation

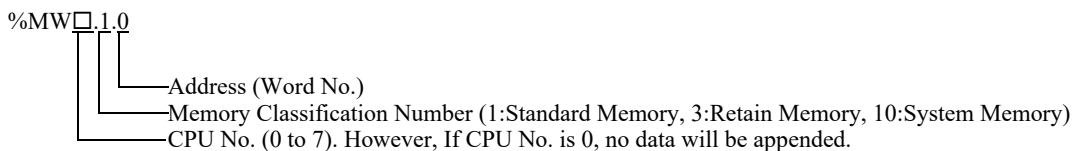

\*4 Standard and Retain Memory sizes can be changed. However, the total memory size is fixed. (For details, refer to the manual of External Device).

- \*5 In Case of “Connected to FFK120A”,  
When you write the bit address, the Display reads the word address corresponding to that of the External Device first. Then, it changes the target bit address among the word data once read and returns the word data to the External Device. Note that the correct data may not be written if you change the word address value in the ladder program while the Display reads the data of the External Device and returns it to the External Device.

**NOTE**

- When specifying the address of the External Device directly, always use a setting within the specified AT range of the ladder software. We recommend using an AT-specified- variable for the External Device used on the Display. Please refer to the Micrex-SX Series D300Win <Reference> Users Manual by Fuji Electric Co., Ltd. for details of specifying the AT range and how to set it. When using a variable that is not AT-specified, variable needs to be imported again and screen transfer needs to be executed if ladder program or variable is changed.
- Always use a system area and reading area within the specified AT range.
- Use high performance CPU system area with an address of %MW1.2048 or later.
- Please refer to the GP-Pro EX Reference Manual for system data area.  
Cf. GP-Pro EX Reference Manual "LS Area (Direct Access Method Area)"
- Please refer to the precautions on manual notation for icons in the table.  
 "Manual Symbols and Terminology"

## 6.3 SPH2000

**▬▬▬** This address can be specified as system data area.

Device	Bit Address	Word Address	32bits	Remarks
Input Memory	%IX□.0000.00 - %IX□.0511.15	%IW□.0000 - %IW□.0511	<b>[L/H]</b>	*1 *2
Output Memory	%QX□.0000.00 - %QX□.0511.15	%QW□.0000 - %QW□.0511		*1 *2
Standard Memory	%MX□.1.0000000.00 - %MX□.1.1703935.15	%MW□.1.0000000 - %MW□.1.1703935		*3 *4 *5
Retain Memory	%MX□.3.000000.00 - %MX□.3.262143.15	%MW□.3.000000 - %MW□.3.262143		*3 *4 *5
System Memory	%MX□.10.000000.00 - %MX□.10.065535.15	%MW□.10.000000 - %MW□.10.065535		*3 *5

\*1 Input/Output memory Address Designation is as shown below.

- Bit Designation

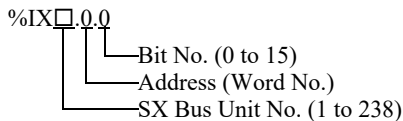

- Word Designation

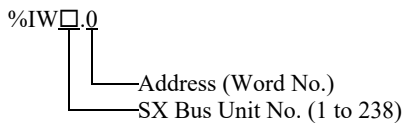
**NOTE**

Please refer to the SX Bus Unit No. details in the manual of External Device.

\*2 In Case of “Connected to FFK120A”, This device is not supported.

\*3 Standard/Retain/System Memory Address Designation is as shown below.

- Bit Designation

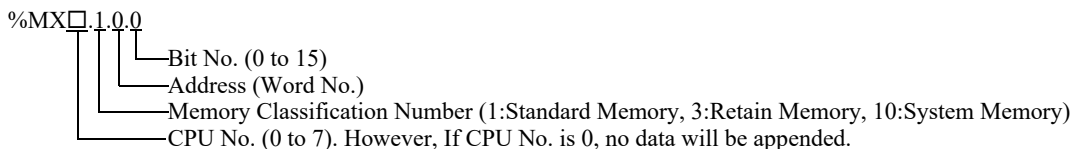

- Word Designation

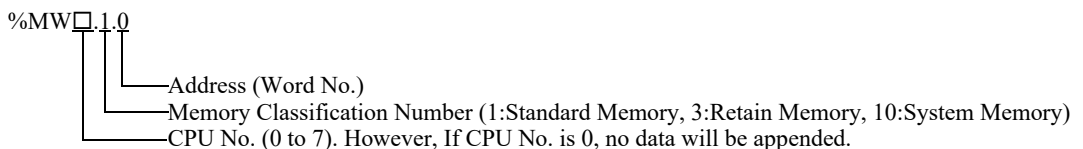

\*4 Standard and Retain Memory sizes can be changed. However, the total memory size is fixed. (For details, refer to the manual of External Device).

- \*5 In Case of “Connected to FFK120A”,  
When you write the bit address, the Display reads the word address corresponding to that of the External Device first. Then, it changes the target bit address among the word data once read and returns the word data to the External Device. Note that the correct data may not be written if you change the word address value in the ladder program while the Display reads the data of the External Device and returns it to the External Device.

**NOTE**

- When specifying the address of the External Device directly, always use a setting within the specified AT range of the ladder software. We recommend using an AT-specified- variable for the External Device used on the Display. Please refer to the Micrex-SX Series D300Win <Reference> Users Manual by Fuji Electric Co., Ltd. for details of specifying the AT range and how to set it. When using a variable that is not AT-specified, variable needs to be imported again and screen transfer needs to be executed if ladder program or variable is changed.
  - Always use a system area and reading area within the specified AT range.
  - Use high performance CPU system area with an address of %MW1.2048 or later.
  - Please refer to the GP-Pro EX Reference Manual for system data area.
- Cf. GP-Pro EX Reference Manual "LS Area (Direct Access Method Area)"
- Please refer to the precautions on manual notation for icons in the table.



 "Manual Symbols and Terminology"

## 6.4 When Using a Variable

### ■ Usable Device

The table below shows the Base Data Types of usable Variables.

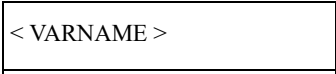
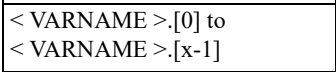
 This address can be specified as system data area.

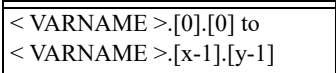
Data Type		Bit Address	Word Address	32bits	Remarks
BOOL	Single Var	<VARNAME>			
	1D Array	<VARNAME>.[0] to <VARNAME>.[x-1]	-	-	*1 *2 *3
	2D Array	< VARNAME >.[0].[0] to < VARNAME >.[x-1].[y-1]			
INT UINT WORD	Single Tag	< VARNAME >.00 to < VARNAME >.15	 < VARNAME >		
	1D Array	< VARNAME >.[0].00 to < VARNAME >.[x-1].15	 < VARNAME >.[0] to < VARNAME >.[x-1]		*1 *2 *4 *5
	2D Array	< VARNAME >.[0].[0].00 to < VARNAME >.[x-1].[y-1].15	 < VARNAME >.[0].[0] to < VARNAME >.[x-1].[y-1]		
DINT UDINT DWORD REAL TIME	Single Tag	< VARNAME >.00 to < VARNAME >.31	< VARNAME >		
	1D Array	< VARNAME >.[0].00 to < VARNAME >.[x-1].31	< VARNAME >.[0] to < VARNAME >.[x-1]	-	*1 *2
	2D Array	< VARNAME >.[0].[0].00 to < VARNAME >.[x-1].[y-1].31	< VARNAME >.[0].[0] to < VARNAME >.[x-1].[y-1]		
STRING	Single Tag	-	<VARNAME>	-	*1 *6

\*1 <VARNAME>: This is the complete "Variable" name including "Worksheet" name and "Structure" name if it is a sub element of a structure. Maximum 255 characters including delimiters ('.') and address part (e.g. bit position and array information).

e.g. BOOL type single tag in a Global Worksheet:

"CONF.MainResource.Global\_Variables.BOOLVAR"

e.g. INT type single tag in a Local Worksheet:

"MainProgram.MainProgramV.INTVAR"

e.g. DINT type bit address:

"MainProgram.MainProgramV.DINTVAR.30"

e.g. REAL type 2D array:

"MainProgram.MainProgramV.REALARRAY[1].[2]"

e.g. DINT from a TIMER structure:

"MainProgram.MainProgramV.TIMERVAR.PRE"

e.g. BOOL from a User Defined Structure :

"CONF.MainResource.Global\_Variables.USERSTRUCTURE\_A.MYTIMER.EN"

- You cannot start names with any of the following text:

LS, USR, SCR, PRT

\*2 Array dimensions: Up to 2D arrays can be created. When a "Variable" is an array, the size is defined.

Range of array elements: -32728 to 32767

Number of array elements: 32768

Usable memory size for 1 variable: Less than 65535 words

\*3 BOOL type arrays: The External Device address must start on bit 0. e.g. %MX1.100.0

\*4 The system data area is initially set up with 16 words of items. If you set up less than 16 words of items, after allocating a 16 word or larger array of tags in the system data area, select only the necessary items.

- \*5 You can only set variables assigned to addresses %MW□.1 or %MW□.3 to the system area.
- \*6 STRING type: Array access is not possible. Also the "STRING" cannot be used as part of a structure.

**NOTE**

- The following derived data types are available for address input with GP-Pro EX.
  - Array data type
    - One-dimensional array
    - Two-dimensional array (an array of arrays)
  - Structural data type
    - Structure
    - Array of structure
    - Structure of array
    - Structure of structure
- When specifying the address of the External Device directly, always use a setting within the specified AT range of the ladder software. We recommend using an AT-specified- variable for the External Device used on the Display. Please refer to the Micrex-SX Series D300Win <Reference> Users Manual by Fuji Electric Co., Ltd. for details of specifying the AT range and how to set it. When using a variable that is not AT-specified, variable needs to be imported again and screen transfer needs to be executed if ladder program or variable is changed.
- Always use a system area and reading area within the specified AT range.
- Use high performance CPU system area with an address of %MW1.2048 or later.
- Please refer to the GP-Pro EX Reference Manual for system data area.

 "Manual Symbols and Terminology"

To use a variable and Derived Data Type that were set by D300win with the GP-Pro EX, CSV file and IEC file need to be imported.

CSV file and IEC file are exported by D300win.

Imported data is saved as variable data.

**NOTE**

- Defined variable data can be used only with this driver. Therefore, variable data defined with other drivers cannot be used with this driver. In the same way, variable data defined with this driver cannot be used with other drivers.
- When IEC file meets any of the following conditions, it cannot be imported. Correct inappropriate conditions and then import the file.
  - There are two or more definitions or keywords (e.g. TYPE and END\_TYPE) in 1 row.  
(When a line break is inserted in the comment, the case is recognized that there are two or more definitions or keywords in 1 row.)
  - There is a structure where array variables are defined.
  - There is an Alias of basic data type.



## ■ Setting Items of [Variable] List Dialog Box

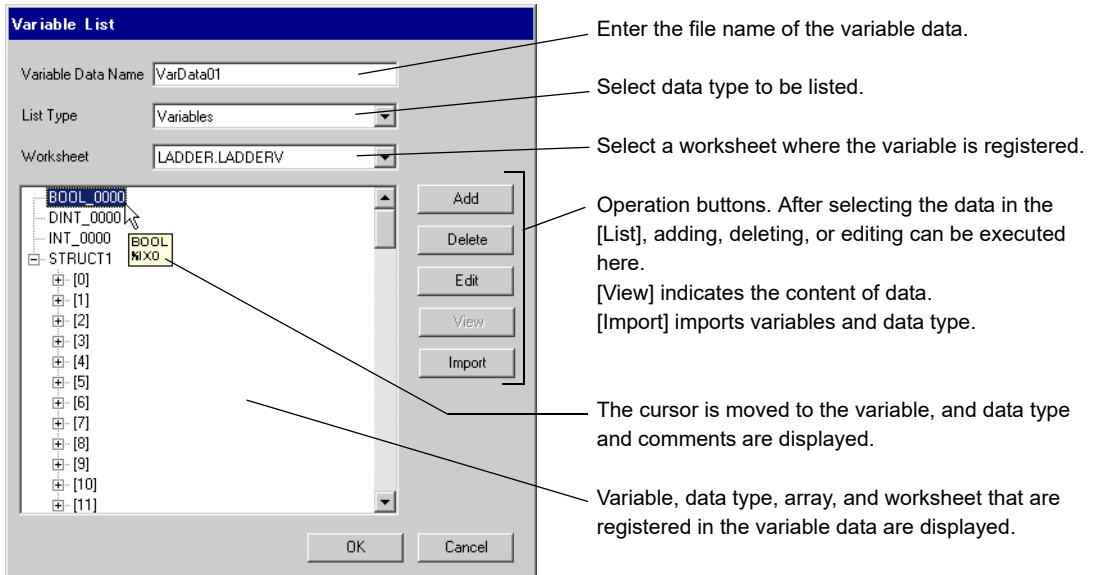

## ■ Importing Variable and Data Type

- 1 Set variable, data type, array, and worksheet with D300win.

Version of D300win that is supported is V3.1.0.0 or later.

- 2 Select [Export] from the [File] menu and select the data to be exported.

Data below needs to be exported.

Data to be exported	Description	File type
Cross reference	Variable and worksheet	CSV
IEC 61131-3	Data type and array	IEC

- 3 Make [Individual Device Settings] dialog box displayed with the GP-ProEX, and put a check to [Use Variable Data]. Then click [New].

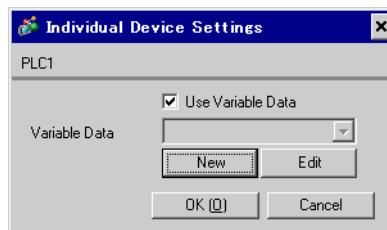

- 4 Enter the name of variable data to save the setting in the [Variable Data Name].

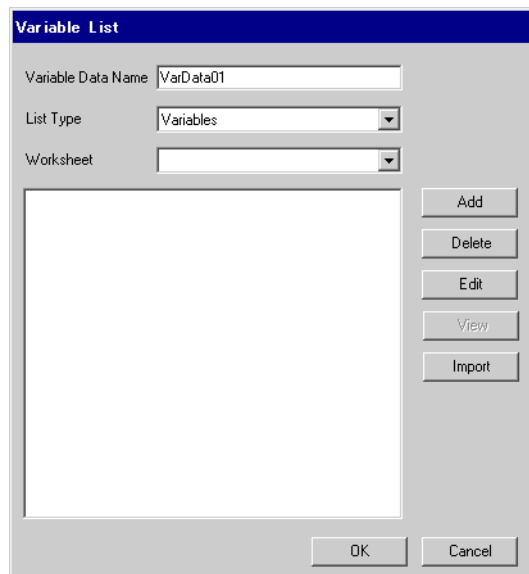

5 Click [Import] to import CSV file and IEC file that were exported in the Procedure 2.

Import IEC file first followed by CSV file.

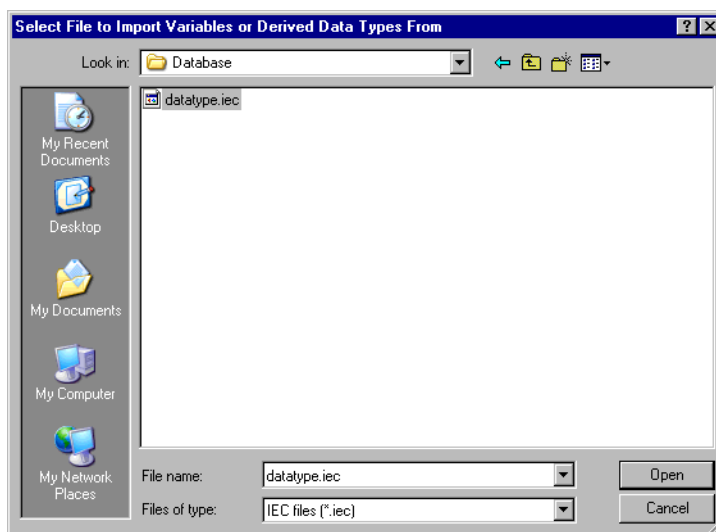

**NOTE**

- When CSV file including variable with the user-defined data type is imported prior to IEC file, an error, "Unknown Data Type was found" is displayed and variable is not imported. Import IEC file first in order to register the user-defined data type.
- Arrays, structures and parameters whose name length exceeds 30 single-byte characters cannot be imported. Set the name length to 30 single-byte characters or less and then import them.

6 Confirm the registered data and click [OK].

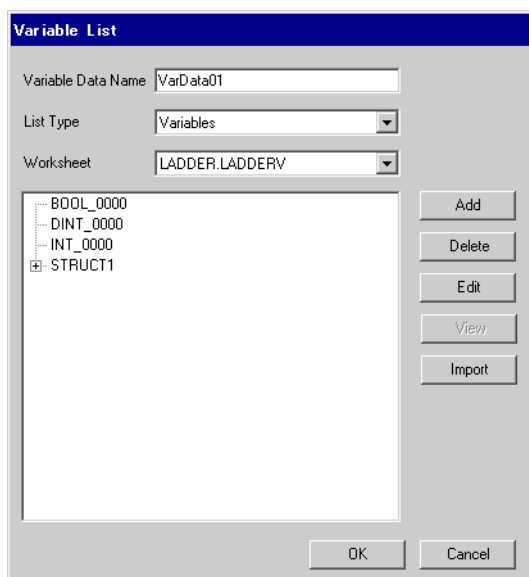

## ■ Making New Variable Data

If variable data is not imported, make variable data using the following procedures.

### ◆ Making Variable

- 1 Select "Variables" from the [List Type] of the [Variable List] dialog box.

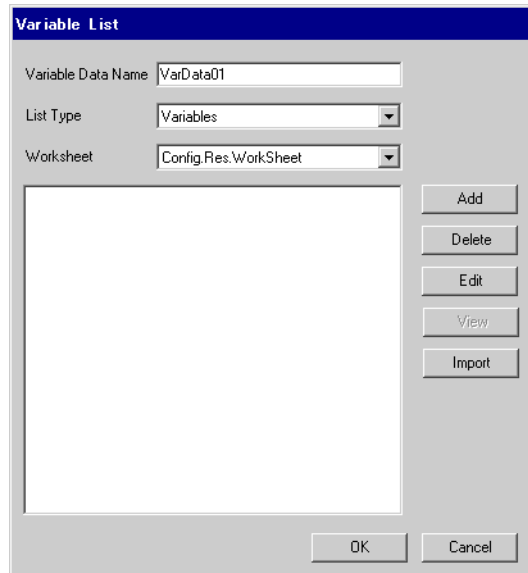

- 2 Click [Add] to display [Variable] dialog box.

#### NOTE

- To add a variable, the worksheet needs to be set. Make the worksheet before making the variable.

☞ "◆ Making a Worksheet" (page 55)

- 3 Enter "Name", "Data Type", "Address" and "Comment" and click [OK].

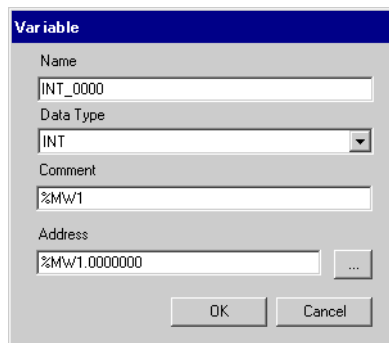

### ◆ Making Derived Data Type

1 Select "Structures" from the [List Type] of the [Variable List] dialog box.

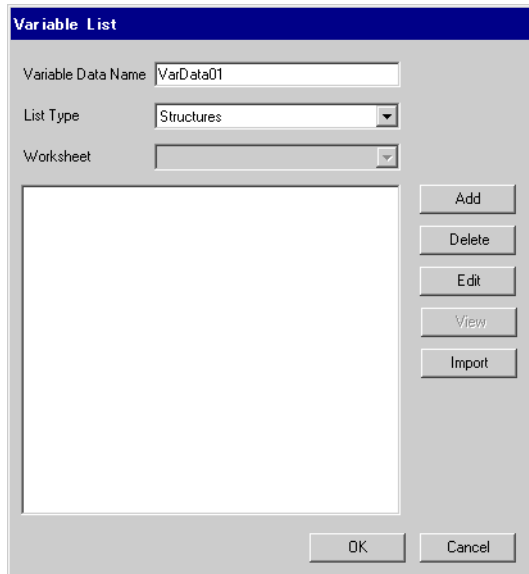

2 Click [Add] to display [Derived Data Type (Structure)] dialog box.

3 Enter the "Name" of the member and "Data Type" to be included in "Derived Data Type Name" and data type and click [OK].

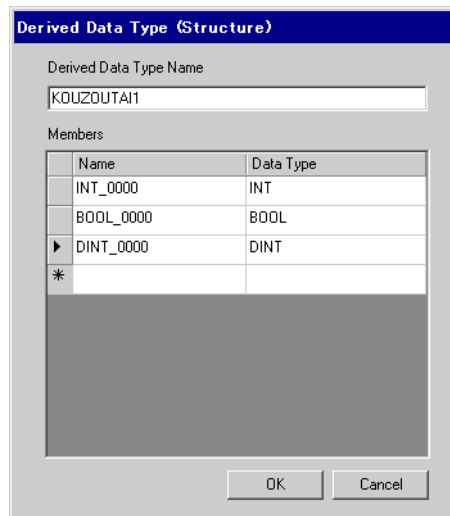

**◆ Making an Array**

1 Select "Arrays" from the [List Type] of the [Variable List] dialog box.

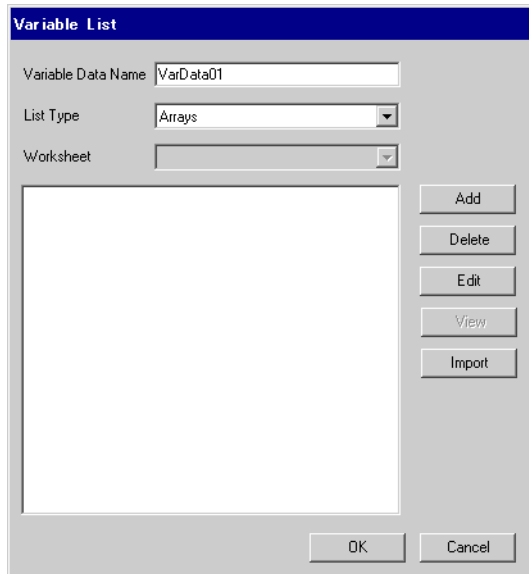

2 Click [Add] to display [Derived Data Type (Array)] dialog box.

3 Enter "Array Name", "Data Type", "Start Element" and "End Element" and click [OK].

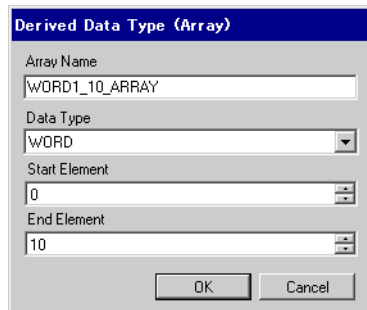

**◆ Making a Worksheet**

1 Select "Worksheets" from the [List Type] of the [Variable List] dialog box.

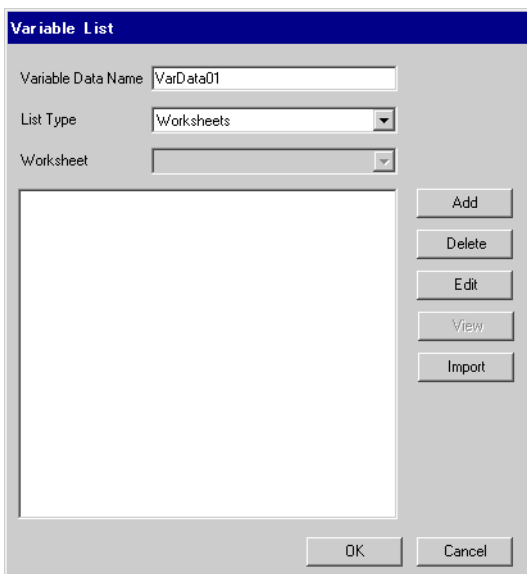

2 Click [Add] to display [Worksheet] dialog box.

3 Enter "Configuration", "Resource/Program" and "Worksheet" and click [OK].

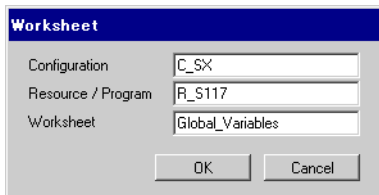

## 7 Device Code and Address Code

Use device code and address code when you select "Device Type & Address" for the address type in data displays.

**NOTE**

- When using a variable, device code and address code cannot be used.

Device	Device Name	Device Code (HEX)	Address Code
Input Memory	%IX/%IW	0083	SX Bus Unit No. × 0x1000000 + Word Address
Output Memory	%QX/%QW	0084	SX Bus Unit No. × 0x1000000 + Word Address
Standard Memory	%MX1./%MW1.	0080	CPU No. × 0x1000000 + Word Address
Retain Memory	%MX3./%MW3.	0081	CPU No. × 0x1000000 + Word Address
System Memory	%MX10./%MW10.	0082	CPU No. × 0x1000000 + Word Address



## 8 Error Messages

Error messages are displayed on the screen of Display as follows: "No. : Device Name: Error Message (Error Occurrence Area)". Each description is shown below.

Item	Description
No.	Error No.
Device Name	Name of External Device where error occurs. Device name is a title of External Device set with GP-Pro EX. (Initial value [PLC1])
Error Message	Displays messages related to the error which occurs.
Error Occurrence Area	<p>Displays IP address or device address of External Device where error occurs, or error codes received from External Device.</p> <p><b>NOTE</b></p> <ul style="list-style-type: none"> <li>• IP address is displayed such as "IP address (Decimal): MAC address (Hex)".</li> <li>• Device address is displayed such as "Address: Device address".</li> <li>• Received error codes are displayed such as "Decimal [Hex]".</li> </ul>

Display Examples of Error Messages

"RHAA035: PLC1: Error has been responded for device write command (Error Code: 2 [02H])"

**NOTE**

- Refer to your External Device manual for details on received error codes.
- Please refer to "Display-related errors" of "Maintenance/Troubleshooting Guide" for a common error message to the driver.

### ■ Error Code Unique for Driver

Error Code	Description	Comment
0x10	CPU Error	An error occurs in the CPU and a command cannot be executed.
0x12	Command cannot be executed.	Due to CPU's key switch condition, a command cannot be executed.
0x23	During transmission interlocking	Transmission is interlocked due to a loader command from another device.
0x28	During command processing	Requested command cannot be executed because other command is in process.
0x2B	During other loader processing	Request command cannot be executed because D300win loader is in process.
0x2F	Initialization incomplete	Requested command cannot be executed because system is initializing.
0x44	Memory addressing error	Specified address exceeds effective area.
0x45	Memory size over	Address + reading/the number of written words exceeds the effective area.

**■ Error Message Unique for Driver**

Error Code	Error Message	Description
RHxx128	"(Node Name):The number of specified destination module is not existed.(Error Code: [Hex])"	Command destination specification error. Check module is present / online and that the configuration is correct.