

Power Mate Series Driver

1	System Configuration.....	3
2	Selection of External Device	8
3	Example of Communication Setting.....	9
4	Setup Items.....	14
5	Cable Diagram	17
6	Supported Device.....	42
7	Device Code and Address Code.....	47
8	Error Messages.....	48

Introduction

This manual describes how to connect the Display and the External Device (target PLC).

In this manual, the connection procedure will be described by following the below sections:

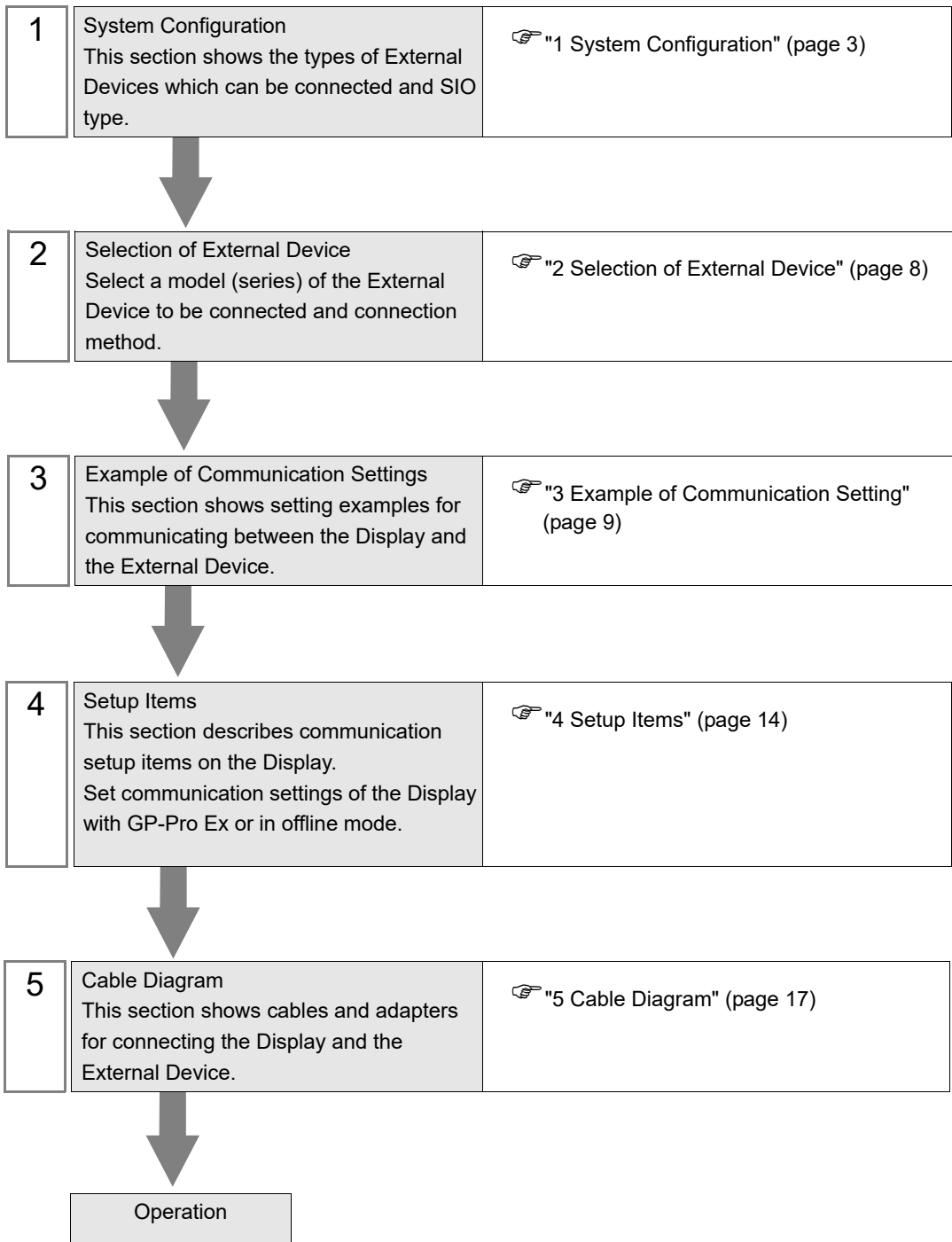

1 System Configuration

The system configuration in the case when the External Device and the Display are connected is shown.

IMPORTANT

- Be sure to inform the Fanuc Corporation clearly that the system will be connected with Display.

Series	CPU	Link I/F	SIO Type	Setting Example	Cable Diagram
Fanuc Power Mate Series	Power Mate-MODEL D	Port on CPU Unit*1	RS422/485 (4wire)	Setting Example 1 (page 9)	Cable Diagram 1 (page 17)
Fanuc Power Mate i Series	Power Mate i-MODEL D Power Mate i-MODEL H	Port on CPU Unit*1	RS422/485 (4wire)	Setting Example 1 (page 9)	Cable Diagram 4 (page 33)
Fanuc Series*2	16-Model C	Port2 on CPU Unit*1	RS232C	Setting Example 2 (page 10)	Cable Diagram 2 (page 26)
	16-Model C 18-Model C 16i-Model A 16i-Model B 18i-Model A 18i-Model B 21i-Model A 21i-Model B 30i-Model A 31i-Model A 32i-Model A	Port2 on CPU Unit*1	RS232C	Setting Example 2 (page 10)	Cable Diagram 3 (page 29)
	35i-Model B	Port2 on CPU Unit*1	RS232C	Setting Example 3 (page 12)	Cable Diagram 3 (page 29)

*1 The serial port used for the connection is different according to CPU. The serial port that can be used is as follows.

CPU	Serial port
PowerMate-MODEL D	JD14
16-Model C	JD5B
18-Model C 16i-Model A 16i-Model B 18i-Model A 18i-Model B 21i-Model A 21i-Model B	JD36B
30i-Model A 31i-Model A 32i-Model A 35i-Model B	JD36A or JD54
i-Model D i-Model H	JD40

*2 The touch panel function on the LCD of the CNC cannot be used simultaneously with the Display.

■ Connection Configuration

- 1:1 Connection



■ IPC COM Port

When connecting IPC with an External Device, the COM port used depends on the series and SIO type. Please refer to the IPC manual for details.

Usable port

Series	Usable Port		
	RS-232C	RS-422/485(4 wire)	RS-422/485(2 wire)
PS-2000B	COM1 ^{*1} , COM2, COM3 ^{*1} , COM4	-	-
PS-3450A, PS-3451A, PS3000-BA, PS3001-BD	COM1, COM2 ^{*1*2}	COM2 ^{*1*2}	COM2 ^{*1*2}
PS-3650A (T41 model), PS-3651A (T41 model)	COM1 ^{*1}	-	-
PS-3650A (T42 model), PS-3651A (T42 model)	COM1 ^{*1*2} , COM2	COM1 ^{*1*2}	COM1 ^{*1*2}
PS-3700A (Pentium®4-M) PS-3710A	COM1 ^{*1} , COM2 ^{*1} , COM3 ^{*2} , COM4	COM3 ^{*2}	COM3 ^{*2}
PS-3711A	COM1 ^{*1} , COM2 ^{*2}	COM2 ^{*2}	COM2 ^{*2}
PS4000 ^{*3}	COM1, COM2	-	-
PL3000	COM1 ^{*1*2} , COM2 ^{*1} , COM3, COM4	COM1 ^{*1*2}	COM1 ^{*1*2}
PE-4000B Atom N270	COM1, COM2	-	-
PE-4000B Atom N2600	COM1, COM2	COM3 ^{*4} , COM4 ^{*4} , COM5 ^{*4} , COM6 ^{*4}	COM3 ^{*4} , COM4 ^{*4} , COM5 ^{*4} , COM6 ^{*4}
PS5000 (Slim Panel Type Core i3 Model) ^{*5*6}	COM1, COM2 ^{*4}	COM2 ^{*4}	COM2 ^{*4}
PS5000 (Slim Panel Type Atom Model) ^{*5*6}	COM1, COM2 ^{*7}	COM2 ^{*7}	COM2 ^{*7}
PS5000 (Enclosed Panel Type) ^{*8}	COM1	-	-
PS5000 (Modular Type PFXPU/PFXPP) ^{*5*6} PS5000 (Modular Type PFXPL2B5-6)	COM1 ^{*7}	COM1 ^{*7}	COM1 ^{*7}
PS5000 (Modular Type PFXPL2B1-4)	COM1, COM2 ^{*7}	COM2 ^{*7}	COM2 ^{*7}
PS6000 (Advanced Box) PS6000 (Standard Box)	COM1 ^{*9}	*10	*10
PS6000 (Basic Box)	COM1 ^{*9}	COM1 ^{*9}	COM1 ^{*9}

*1 The RI/5V can be switched. Use the IPC's switch to change if necessary.

*2 Set up the SIO type with the DIP Switch. Please set up as follows according to SIO type to be used.

- *3 When making communication between an External Device and COM port on the Expansion slot, only RS-232C is supported. However, ER (DTR/CTS) control cannot be executed because of the specification of COM port.
For connection with External Device, use user-created cables and disable Pin Nos. 1, 4, 6 and 9. Please refer to the IPC manual for details of pin layout.
- *4 Set up the SIO type with the BIOS. Please refer to the IPC manual for details of BIOS.
- *5 When setting up communication between an External Device and the RS-232C/422/485 interface module, use the IPC (RS-232C) or PS5000 (RS-422/485) cable diagrams. However, when using PFXZPBMPR42P2 in a RS-422/485 (4-wire) configuration with no flow control, connect 7.RTS+ and 8.CTS+, and connect 6.RTS- and 9.CTS-.
When using RS-422/485 communication with External Devices, you may need to reduce the transmission speed and increase the TX Wait time.
- *6 To use RS-422/485 communication on the RS-232C/422/485 interface module, the DIP Switch setting is required. Please refer to "Knowledge Base" (FAQs) on the support site. (<http://www.pro-face.com/trans/en/manual/1001.html>)

Settings	FAQ ID
PFXZPBMPR42P2, RS422/485 change method	FA263858
PFXZPBMPR42P2 termination resistor setting	FA263974
PFXZPBMPR44P2, RS422/485 change method	FA264087
PFXZPBMPR44P2 termination resistor setting	FA264088

- *7 Set up the SIO type with the DIP Switch. Please refer to the IPC manual for details of DIP Switch. The BOX Atom has not a switch to set the RS-232C, RS-422/485 mode. Use the BIOS for the setting.
- *8 For the connection with the External Device, on the user-created cable read as if the connector on the Display-side is a M12 A-coding 8 pin socket. The pin assignment is the same as described in the cable diagram. For the M12 A-coding connector, use PFXZPSCNM122.
- *9 In addition to COM1, you can also use the COM port on the optional interface.
- *10 Install the optional interface in the expansion slot.

DIP Switch settings (PL3000 / PS3000 Series)

RS-232C

DIP Switch	Setting	Description
1	OFF*1	Reserved (always OFF)
2	OFF	SIO type: RS-232C
3	OFF	
4	OFF	Output mode of SD (TXD) data: Always output
5	OFF	Terminal resistance (220Ω) insertion to SD (TXD): None
6	OFF	Terminal resistance (220Ω) insertion to RD (RXD): None
7	OFF	Short-circuit of SDA (TXA) and RDA (RXA): Not available
8	OFF	Short-circuit of SDB (TXB) and RDB (RXB): Not available
9	OFF	RS (RTS) Auto control mode: Disabled
10	OFF	

*1 When using PS-3450A, PS-3451A, PS3000-BA and PS3001-BD, turn ON the set value.

RS-422/485 (4 wire)

DIP Switch	Setting	Description
1	OFF	Reserved (always OFF)
2	ON	SIO type: RS-422/485
3	ON	
4	OFF	Output mode of SD (TXD) data: Always output
5	OFF	Terminal resistance (220Ω) insertion to SD (TXD): None
6	OFF	Terminal resistance (220Ω) insertion to RD (RXD): None
7	OFF	Short-circuit of SDA (TXA) and RDA (RXA): Not available
8	OFF	Short-circuit of SDB (TXB) and RDB (RXB): Not available
9	OFF	RS (RTS) Auto control mode: Disabled
10	OFF	

RS-422/485 (2 wire)

DIP Switch	Setting	Description
1	OFF	Reserved (always OFF)
2	ON	SIO type: RS-422/485
3	ON	
4	OFF	Output mode of SD (TXD) data: Always output
5	OFF	Terminal resistance (220Ω) insertion to SD (TXD): None
6	OFF	Terminal resistance (220Ω) insertion to RD (RXD): None
7	ON	Short-circuit of SDA (TXA) and RDA (RXA): Available
8	ON	Short-circuit of SDB (TXB) and RDB (RXB): Available
9	ON	RS (RTS) Auto control mode: Enabled
10	ON	

2 Selection of External Device

Select the External Device to be connected to the Display.

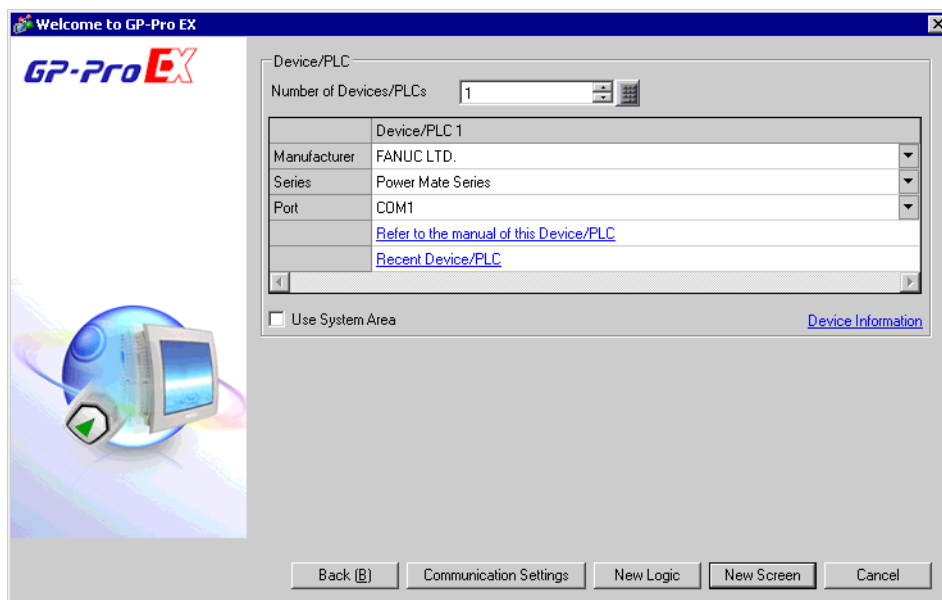

Setup Items	Setup Description
Number of Devices/PLCs	Enter an integer from 1 to 4 to define the number of Devices/PLCs to connect to the display.
Manufacturer	Select the manufacturer of the External Device to connect. Select "FANUC LTD.".
Series	Select the External Device model (series) and the connection method. Select "Power Mate Series". In System configuration, make sure the External Device you are connecting is supported by "Power Mate Series". ☞ "1 System Configuration" (page 3)
Port	Select the Display port to connect to the External Device.
Use System Area	Check this option to synchronize the system data area of the Display and the device (memory) of the External Device. When synchronized, you can use the External Device's ladder program to switch the display or display the window on the Display. Cf. GP-Pro EX Reference Manual "LS Area (Direct Access Method Area)" This feature can also be set in GP-Pro EX or in the Display's offline mode. Cf. GP-Pro EX Reference Manual "System Settings [Display Unit] - [System Area] Settings Guide" Cf. Maintenance/Troubleshooting Guide "Main Unit - System Area Settings"

3 Example of Communication Setting

Examples of communication settings of the Display and the External Device, recommended by Pro-face, are shown.

3.1 Setting Example 1

■ Settings of GP-Pro EX

◆ Communication Settings

To display the setup screen, from the [Project] menu, point to [System Settings] and select [Device/PLC].

Device/PLC 1

Summary [Change Device/PLC](#)

Manufacturer Series Port

Text Data Mode [Change](#)

Communication Settings

SIO Type RS232C RS422/485(2wire) RS422/485(4wire)

Speed

Data Length 7 8

Parity NONE EVEN ODD

Stop Bit 1 2

Flow Control NONE ER(DTR/CTS) XON/XOFF

Timeout (sec)

Retry

Wait To Send (ms)

RI / VCC RI VCC

In the case of RS232C, you can select the 9th pin to RI (Input) or VCC (5V Power Supply). If you use the Digital's RS232C Isolation Unit, please select it to VCC.

Device-Specific Settings

Allowable Number of Devices/PLCs [Add Device](#)

No.	Device Name	Settings
1	PLC1	

[Add Indirect Device](#)

■ Settings of External Device

Communication setting of External Device is as follows, and cannot be changed.

Setup Items	Setup Description
SIO Type	RS422/485 (4wire)
Data Rate	19200 bps
Data Length	8 bits
Parity	Even
Stop Bits	1 bit
Flow Control	None

3.2 Setting Example 2

■ Settings of GP-Pro EX

◆ Communication Settings

To display the setup screen, from the [Project] menu, point to [System Settings] and select [Device/PLC].

Device/PLC 1

Summary [Change Device/PLC](#)

Manufacturer Series Port

Text Data Mode [Change](#)

Communication Settings

RS232C
 RS422/485(2wire)
 RS422/485(4wire)

Speed

Data Length 7 8

Parity NONE EVEN ODD

Stop Bit 1 2

Flow Control NONE ER(DTR/CTS) XON/XOFF

Timeout (sec)

Retry

Wait To Send (ms)

RI VCC

In the case of RS232C, you can select the 9th pin to RI (Input) or VCC (5V Power Supply). If you use the Digital's RS232C Isolation Unit, please select it to VCC.

Device-Specific Settings

Allowable Number of Devices/PLCs [Add Device](#)

No.	Device Name	Settings
<input type="button" value="1"/>	<input type="text" value="PLC1"/>	<input type="button" value="Settings"/>

■ Settings of External Device

Speed is set up by setting up the parameter by which a monitor is carried out by display of External Device. Other setup is fixed values and cannot be changed.

Setup Items	Setup Description
SIO Type	RS232C
Speed	Sets up with a parameter (refer to procedure).
Data Length	8 bits
Parity	Even
Stop Bits	1 bit
Flow Control	None

◆ Procedure

The setting method of speed is explained to an example for 30i-Model A.

1 Permit the parameter writing.

Press the [OFFSET] key of an External Device operation board, and select the [Stting].

Change "0" of parameter writing into "1", and press the [INPUT] key.

2 Setting the parameter for display connection.

Press the [MDI] key of External Device operation board, and shift to MDI mode.

Press the [SYSTEM] key in MDI mode and the parameter screen is displayed.

Press the [Next page] and the parameter input screen is displayed.

Input the "3119" into parameter No. and the 3rd (3119. 3) bit is set to 0.

3 Setting the speed.

Setting the 1st (13101. 1) bit of parameter No.13101 to 1, and the setting value is written in parameter No.123.

Setup Description (Dec)	Data Rate (bps)
9	2400
10	4800
11	9600
12	19200

NOTE • When the 1st bit of parameter No.13101 is 0, a transfer rate is 19200bps fixation. When communicating by 19200bps, operation of Procedure 3 is unnecessary.

4 Turn off the power supply of External Device, and turn on the power supply again.

3.3 Setting Example 3

■ Settings of GP-Pro EX

◆ Communication Settings

To display the setup screen, from the [Project] menu, point to [System Settings] and select [Device/PLC].

Device/PLC 1

Summary [Change Device/PLC](#)

Manufacturer Series Port

Text Data Mode [Change](#)

Communication Settings

RS232C
 RS422/485(2wire)
 RS422/485(4wire)

Speed

Data Length 7 8

Parity NONE EVEN ODD

Stop Bit 1 2

Flow Control NONE ER(DTR/CTS) XON/XOFF

Timeout (sec)

Retry

Wait To Send (ms)

RI
 VCC

In the case of RS232C, you can select the 9th pin to RI (Input) or VCC (5V Power Supply). If you use the Digital's RS232C Isolation Unit, please select it to VCC.

Device-Specific Settings

Allowable Number of Devices/PLCs [Add Device](#)

No.	Device Name	Settings
<input type="button" value="1"/>	<input type="text" value="PLC1"/>	<input type="button" value="Settings"/>

[Add Indirect Device](#)

■ Settings of External Device

Use the CNC Screen Display Function software for setting up communication with the External Device. Refer to your External Device manual for details.

◆ Procedure

- 1 Set the IP address of the personal computer to "192.168.1.200".
- 2 Set the IP address of the External Device to "192.168.1.10 +N".
The value of N is set with the rotary switch.
- 3 Connect an Ethernet cable to the CD38A Ethernet port and start the CNC Screen Display Function software.
- 4 Set the IP address of the HOST to "192.168.1.10".
- 5 From the [View] menu, select [Function key].
- 6 Click the [SYS] button until the parameter screen appears.
- 7 Enter the parameter number at command prompt A> and click [NO. SEARCH].
- 8 Enter the setting value at command prompt A> and click [Enter].

Setup Items	Parameter Number	Setting Value
I/O Channel	00020	2: RS-232C Serial Port 2 (JD-36A)
NFD / ASI / SB2	00121	0: 1Bit
IO SELECT CH2	00122	4: RS-232C
BAUDRATE CH2	00123	12: 19200bps

- 9 Turn off the power supply of External Device, and turn on the power supply again.

4 Setup Items

Set communication settings of the Display with GP-Pro EX or in offline mode of the Display.

The setting of each parameter must be identical to that of External Device.

☞ "3 Example of Communication Setting" (page 9)

4.1 Setup Items in GP-Pro EX

■ Communication Settings

To display the setup screen, from the [Project] menu, point to [System Settings] and select [Device/PLC].

Device/PLC 1

Summary [Change Device/PLC](#)

Manufacturer Series Port

Text Data Mode [Change](#)

Communication Settings

SIO Type RS232C RS422/485(2wire) RS422/485(4wire)

Speed

Data Length 7 8

Parity NONE EVEN ODD

Stop Bit 1 2

Flow Control NONE ER(DTR/CTS) XON/XOFF

Timeout (sec)

Retry

Wait To Send (ms)

RI / VCC RI VCC

In the case of RS232C, you can select the 9th pin to RI (Input) or VCC (5V Power Supply). If you use the Digital's RS232C Isolation Unit, please select it to VCC.

Device-Specific Settings

Allowable Number of Devices/PLCs [Add Device](#)

No.	Device Name	Settings
1	PLC1	<input type="button" value="Settings"/>

Setup Items	Setup Description
SIO Type	Select the SIO type to communicate with the External Device.
Speed	Select speed between the External Device and the Display.
Data Length	Display data length.
Parity	Select how to check parity.
Stop Bit	Select stop bit length.
Flow Control	Select the communication control method to prevent overflow of transmission and reception data.
Timeout	Use an integer from 1 to 127 to enter the time (s) for which the Display waits for the response from the External Device.
Retry	In case of no response from the External Device, use an integer from 0 to 255 to enter how many times the Display retransmits the command.
Wait To Send	Use an integer from 0 to 255 to enter standby time (ms) for the Display from receiving packets to transmitting next commands.
RI/VCC	You can switch RI/VCC of the 9th pin when you select RS232C for SIO type. It is necessary to change RI/5V by changeover switch of IPC when connect with IPC. Please refer to the manual of the IPC for more detail.

NOTE

- Refer to the GP-Pro EX Reference Manual for Indirect Device.
Cf. GP-Pro EX Reference Manual "Changing the Device/PLC at Runtime (Indirect Device)"

4.2 Setup Items in Offline Mode

NOTE

- Refer to the Maintenance/Troubleshooting Guide for information on how to enter offline mode or about the operation.

Cf. Maintenance/Troubleshooting Guide "Offline Mode"

- The number of the setup items to be displayed for 1 page in the offline mode depends on the Display in use. Please refer to the Reference manual for details.

◆ Communication Settings

To display the setting screen, touch [Device/PLC Settings] from [Peripheral Settings] in offline mode. Touch the External Device you want to set from the displayed list.

Comm.	Option			
Power Mate Series		[COM1]	Page 1/1	
SIO Type	RS232C			
Speed	19200			
Data Length	8			
Parity	<input type="radio"/> NONE <input checked="" type="radio"/> EVEN <input type="radio"/> ODD			
Stop Bit	<input checked="" type="radio"/> 1 <input type="radio"/> 2			
Flow Control	NONE			
Timeout(s)		3	▼▲	
Retry		2	▼▲	
Wait To Send(ms)		0	▼▲	
Exit		Back		2006/09/29 13:50:16

Setup Items	Setup Description
SIO Type	Select the SIO type to communicate with the External Device. IMPORTANT To make the communication settings correctly, confirm the serial interface specifications of Display unit for [SIO Type]. We cannot guarantee the operation if a communication type that the serial interface does not support is specified. For details concerning the serial interface specifications, refer to the manual for Display unit.
Speed	Select speed between the External Device and the Display.
Data Length	Display data length.
Parity	Select how to check parity.

Setup Items	Setup Description
Stop Bit	Select stop bit length.
Flow Control	Select the communication control method to prevent overflow of transmission and reception data.
Timeout	Use an integer from 1 to 127 to enter the time (s) for which the Display waits for the response from the External Device.
Retry	In case of no response from the External Device, use an integer from 0 to 255 to enter how many times the Display retransmits the command.
Wait To Send	Use an integer from 0 to 255 to enter standby time (ms) for the Display from receiving packets to transmitting next commands.

■ Option

To display the setting screen, touch [Device/PLC Settings] from [Peripheral Settings]. Touch the External Device you want to set from the displayed list, and touch [Option].

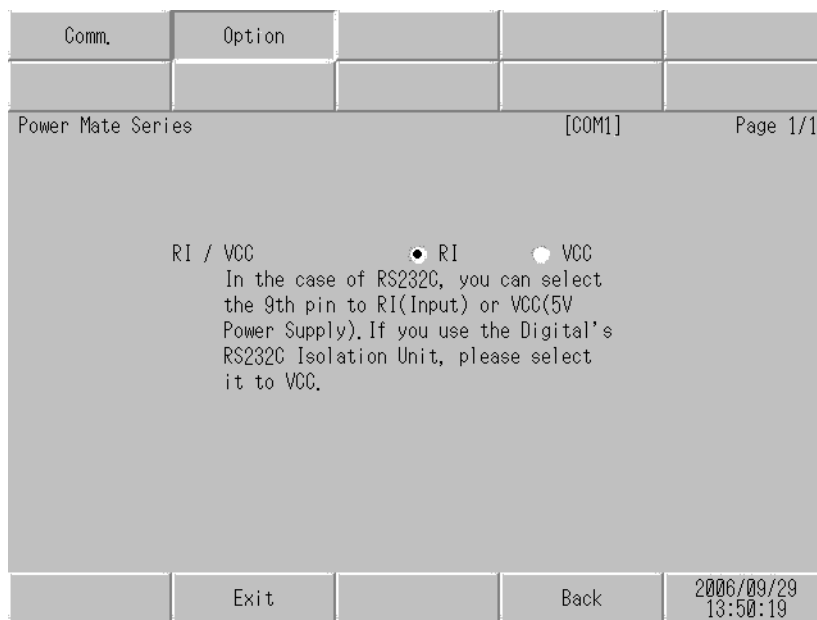

Setup Items	Setup Description
RI/VCC	You can switch RI/VCC of the 9th pin when you select RS232C for SIO type. It is necessary to change RI/5V by changeover switch of IPC when connect with IPC. Please refer to the manual of the IPC for more detail.

NOTE

- GP-4100 series, GP-4*01TM, GP-Rear Module, LT-4*01TM and LT-Rear module do not have the [Option] setting in the off-line mode.

5 Cable Diagram

The following cable diagrams may be different from cable diagrams recommended by External Device Manufacturer.

Please be assured there is no operational problem in applying the cable diagram shown in this manual.

- The FG pin of the External Device body must be grounded according to your country's applicable standard. Refer to your External Device manual for details.
- SG and FG are connected inside the Display. When connecting the External Device to SG, design your system to avoid short-circuit loops.
- Connect an isolation unit if the communication is not stable due to noise or other factors.

5.1 Cable Diagram 1

Display (Connection Port)	Cable		Notes
GP3000* ¹ (COM1) AGP-3302B (COM2) GP-4*01TM (COM1) GP-Rear Module (COM1) ST3000* ² (COM2) LT3000 (COM1) IPC* ³	1A	COM port conversion adapter by Pro-face CA3-ADPCOM-01 + Terminal block conversion adapter by Pro-face CA3-ADPTRM-01 + User-created cable	*4 *5
	1B	User-created cable	
GP3000* ⁶ (COM2)	1C	Online adapter by Pro-face CA4-ADPONL-01 + Terminal block conversion adapter by Pro-face CA3-ADPTRM-01 + User-created cable	*4 *5
	1D	Online adapter by Pro-face CA4-ADPONL-01 + User-created cable	
GP-4106 (COM1) GP-4116T (COM1)	1E	User-created cable	*4 *5
GP4000* ⁷ (COM2) GP-4201T (COM1) SP5000* ⁸ (COM1/2) SP-5B00 (COM2) ST6000* ⁹ (COM2) ST-6200 (COM1) STM6000 (COM1) STC6000 (COM1) PS6000 (Basic Box) (COM1/2)	1F	RS-422 terminal block conversion adapter by Pro-face PFXZCBADTM1 * ¹⁰ + User-created cable	*4 *5
	1B	User-created cable	

Display (Connection Port)	Cable		Notes
PE-4000B ^{*11} PS5000 ^{*11} PS6000 (Optional Interface) ^{*11}	1G	User-created cable	*4 *5

*1 All GP3000 models except AGP-3302B

*2 Except AST-3211A and AST-3302B

*3 Only the COM port which can communicate by RS-422/485 (4 wire) can be used. (Except PE-4000B, PS5000, and PS6000)

■ IPC COM Port (page 5)

*4 Check the cable length with Fanuc Motion Controller PLC's users manual.

*5 Connect a Termination Unit to the Motion Controller's JD15. The Termination Unit, with a resistance of 100Ω is connected to the RDB and RDA points.

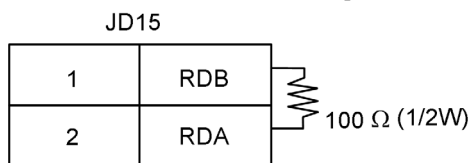

*6 All GP3000 models except GP-3200 series and AGP-3302B

*7 All GP4000 models except GP-4100 series, GP-4*01TM, GP-Rear Module, GP-4201T and GP-4*03T

*8 Except SP-5B00

*9 Except ST-6200

*10 When using a Terminal Block Conversion Adapter (CA3-ADPTRM-01) instead of the RS-422 Terminal Block Conversion Adapter, refer to Cable Diagram 1A.

*11 Only the COM port which can communicate by RS-422/485 (4 wire) can be used.

■ IPC COM Port (page 5)

1A)

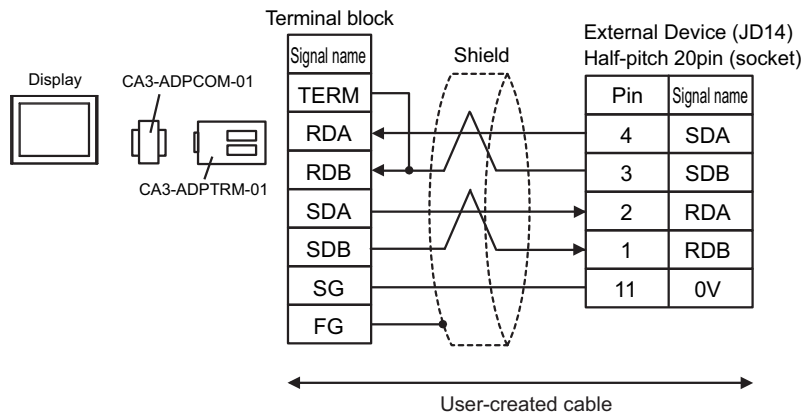

1B)

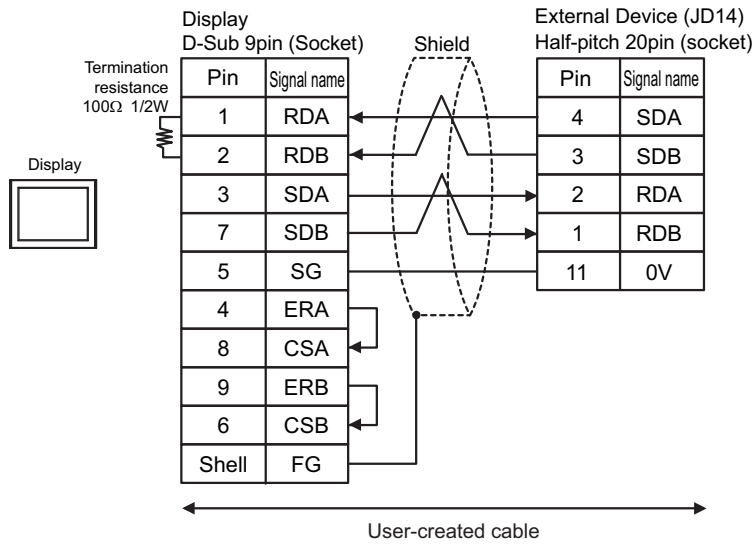

1C)

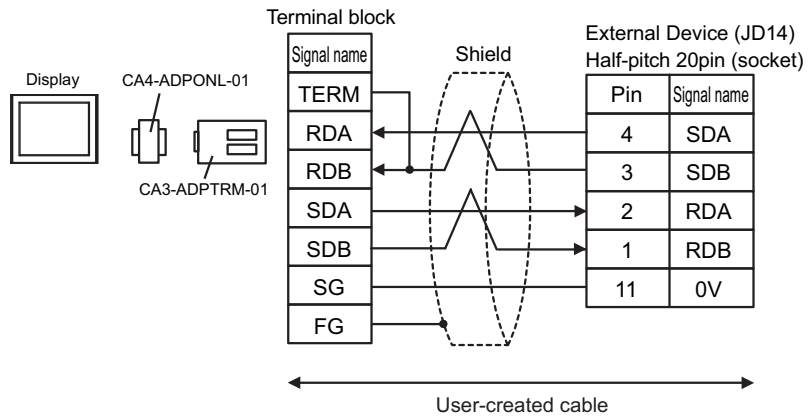

1D)

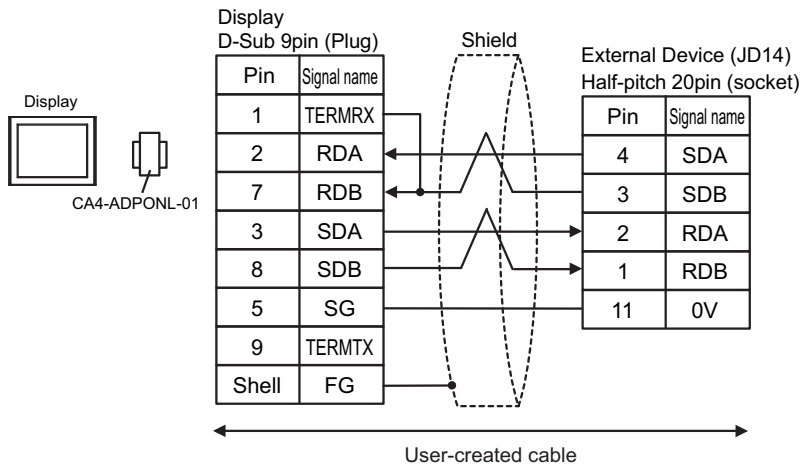

1E)

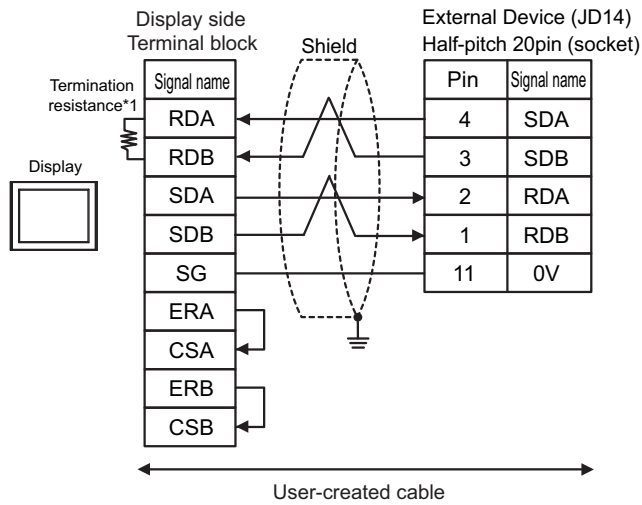

- *1 The resistance in the Display is used as the termination resistance. Set the value of the DIP Switch on the rear of the Display as shown in the table below.

DIP Switch No.	Set Value
1	OFF
2	OFF
3	ON
4	ON

1F)

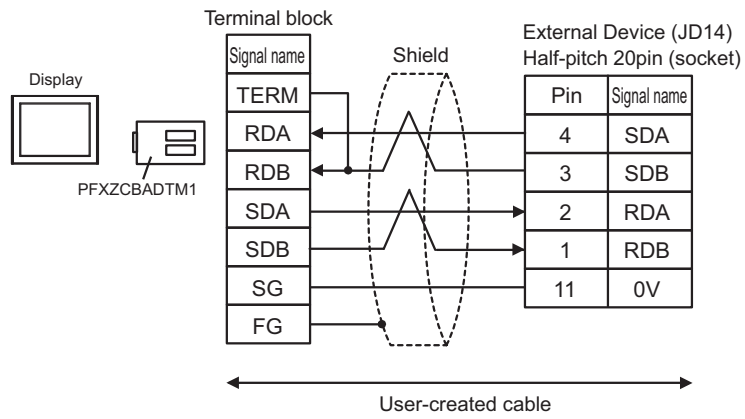

1G)

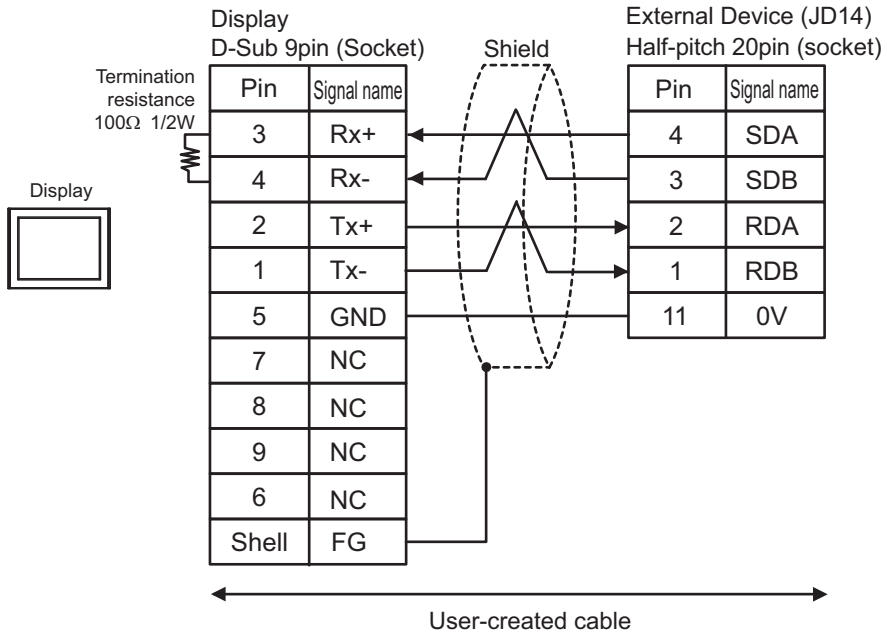

5.2 Cable Diagram 2

Display (Connection Port)	Cable		Notes
GP3000 (COM1) GP4000* ¹ (COM1) SP5000* ² (COM1/2) SP-5B00 (COM1) ST3000 (COM1) ST6000 (COM1) STM6000 (COM1) STC6000 (COM1) LT3000 (COM1) IPC* ³ PC/AT	2A	User-created cable + Fanuc's converting cable A02B-0120-C19	The cable length must be 15m or less.
GP-4105 (COM1) GP-4115T (COM1) GP-4115T3 (COM1)	2B	User-created cable + Fanuc's converting cable A02B-0120-C19	The cable length must be 15m or less.

*1 All GP4000 models except GP-4100 series and GP-4203T

*2 Except SP-5B00

*3 Only the COM port which can communicate by RS-232C can be used.

■ IPC COM Port (page 5)

2A)

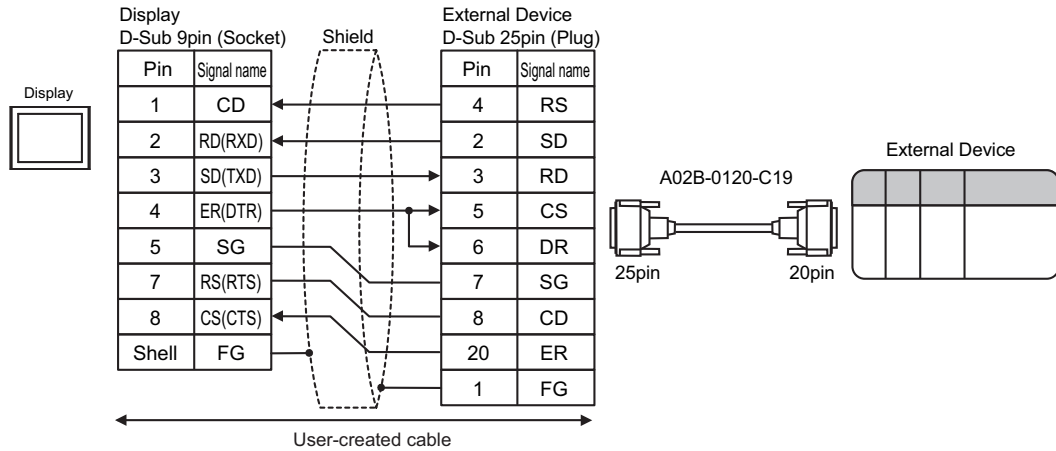
**NOTE**

- The cable length must be 15m maximum.

2B)

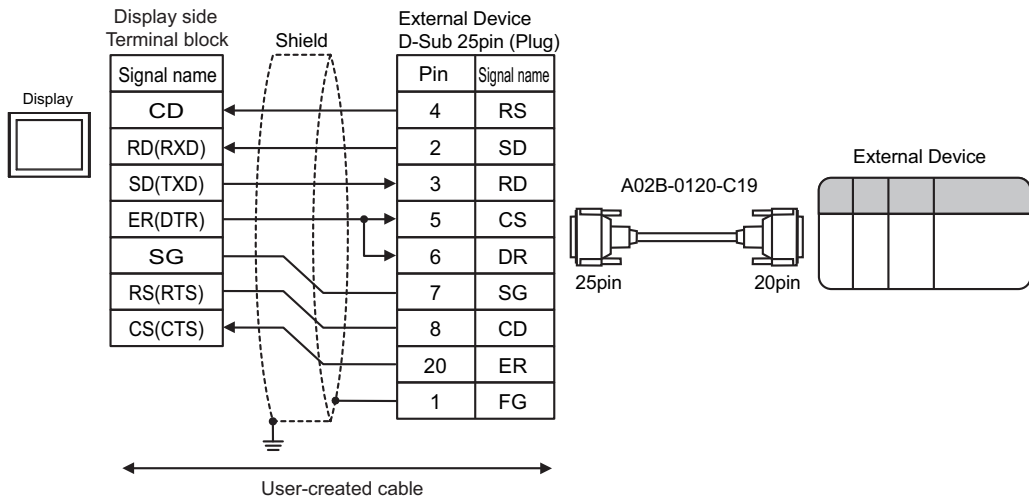
**NOTE**

- The cable length must be 5m maximum.

5.3 Cable Diagram 3

Display (Connection Port)	Cable		Notes
GP3000 (COM1) GP4000* ¹ (COM1) SP5000* ² (COM1/2) SP-5B00 (COM1) ST3000 (COM1) ST6000 (COM1) STM6000 (COM1) STC6000 (COM1) LT3000 (COM1) IPC* ³ PC/AT	3A	User-created cable	The cable length must be 15m or less.
GP-4105 (COM1) GP-4115T (COM1) GP-4115T3 (COM1)	3B	User-created cable	The cable length must be 15m or less.
LT-4*01TM (COM1) LT-Rear Module (COM1)	3C	RJ45 RS-232C Cable (5m) by Pro-face PFXZLMCBRJ21	The cable length must be 5m or less.

*1 All GP4000 models except GP-4100 series and GP-4203T

*2 Except SP-5B00

*3 Only the COM port which can communicate by RS-232C can be used.

■ IPC COM Port (page 5)

3A)

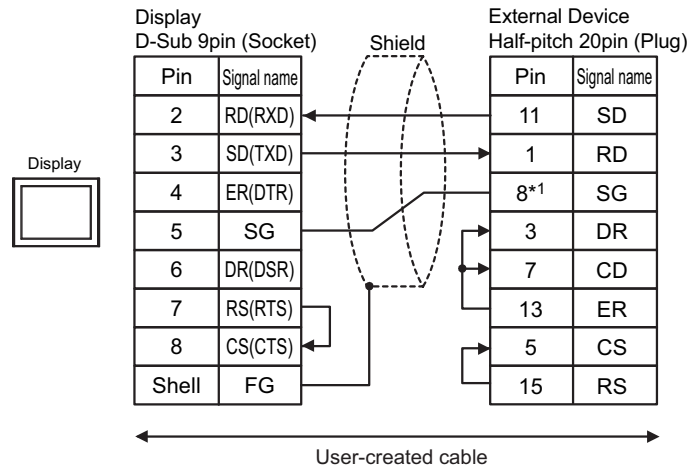
**NOTE**

- The cable length must be 15m maximum.

*1 When connecting with 30i-Model A, 31i-Model A or 32i-Model A, The pin number of SG changes with ports to be used.

Use port	Pin No. of SG
JD36A	8
JD54	4

3B)

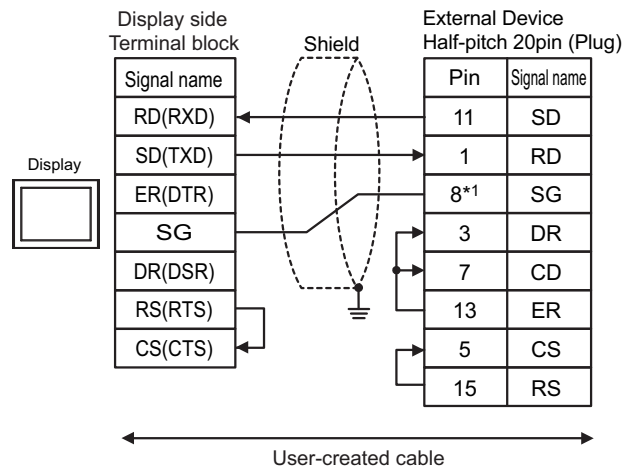
**NOTE**

- The cable length must be 15m maximum.

*1 When connecting with 30i-Model A, 31i-Model A or 32i-Model A, The pin number of SG changes with ports to be used.

Use port	Pin No. of SG
JD36A	8
JD54	4

3C)

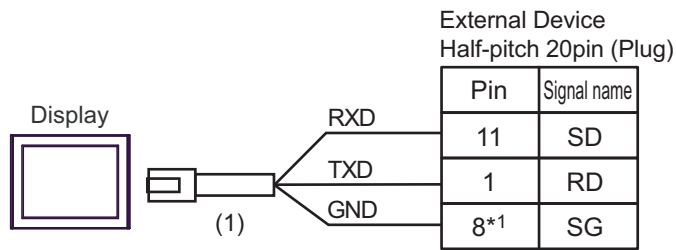

Number	Name	Notes
(1)	RJ45 RS-232C Cable (5m) by Pro-face PFXZLMCBJR21	

NOTE

- The cable length must be 5m maximum.

*1 When connecting with 30i-Model A, 31i-Model A or 32i-Model A, The pin number of SG changes with ports to be used.

Use port	Pin No. of SG
JD36A	8
JD54	4

5.4 Cable Diagram 4

Display (Connection Port)	Cable		Notes
GP3000* ¹ (COM1) AGP-3302B (COM2) GP-4*01TM (COM1) GP-Rear Module (COM1) ST3000* ² (COM2) LT3000 (COM1) IPC* ³	4A	COM port conversion adapter by Pro-face CA3-ADPCOM-01 + Terminal block conversion adapter by Pro-face CA3-ADPTRM-01 + User-created cable	Cable length: 1200m or less
	4B	User-created cable	
GP3000* ⁴ (COM2)	4C	Online adapter by Pro-face CA4-ADPONL-01 + Terminal block conversion adapter by Pro-face CA3-ADPTRM-01 + User-created cable	Cable length: 1200m or less
	4D	Online adapter by Pro-face CA4-ADPONL-01 + User-created cable	
GP-4106 (COM1) GP-4116T (COM1)	4E	User-created cable	Cable length: 1200m or less
GP4000* ⁵ (COM2) GP-4201T (COM1) SP5000* ⁶ (COM1/2) SP-5B00 (COM2) ST6000* ⁷ (COM2) ST-6200 (COM1) STM6000 (COM1) STC6000 (COM1) PS6000 (Basic Box) (COM1/2)	4F	RS-422 terminal block conversion adapter by Pro-face PFXZCBADTM1* ⁸ + User-created cable	Cable length: 1200m or less
	4B	User-created cable	
PE-4000B* ⁹ PS5000* ⁹ PS6000 (Optional Interface)* ⁹	4G	User-created cable	Cable length: 1200m or less

*1 All GP3000 models except AGP-3302B

*2 Except AST-3211A and AST-3302B

*3 Only the COM port which can communicate by RS-422/485 (4 wire) can be used. (Except PE-4000B, PS5000, and PS6000)

■ IPC COM Port (page 5)

*4 All GP3000 models except GP-3200 series and AGP-3302B

*5 All GP4000 models except GP-4100 series, GP-4*01TM, GP-Rear Module, GP-4201T and GP-4*03T

*6 Except SP-5B00

*7 Except ST-6200

*8 When using a Terminal Block Conversion Adapter (CA3-ADPTRM-01) instead of the RS-422 Terminal Block Conversion Adapter, refer to Cable Diagram 4A.

- *9 Only the COM port which can communicate by RS-422/485 (4 wire) can be used.
- IPC COM Port (page 5)

4A)

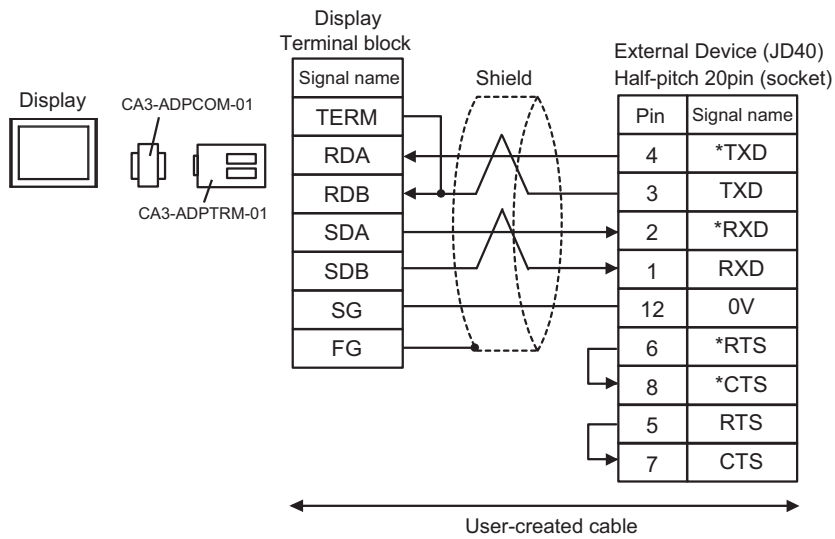
**NOTE**

- The cable length must be 1200m maximum.

4B)

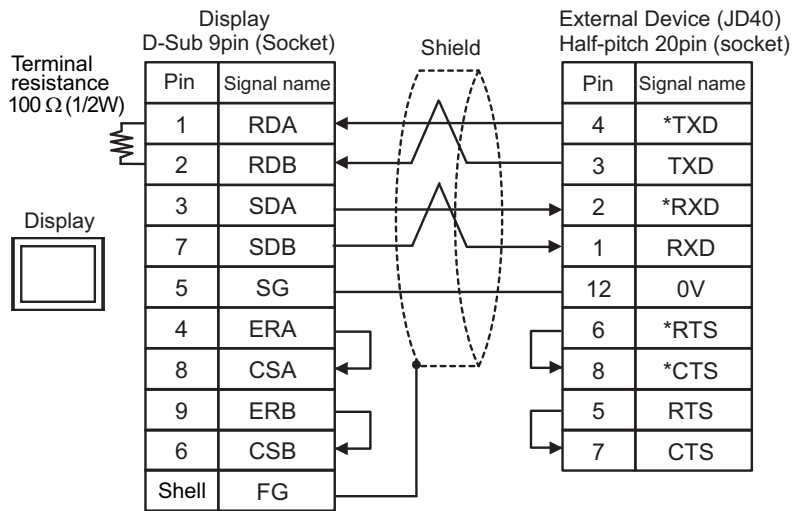
**NOTE**

- The cable length must be 1200m maximum.

4C)

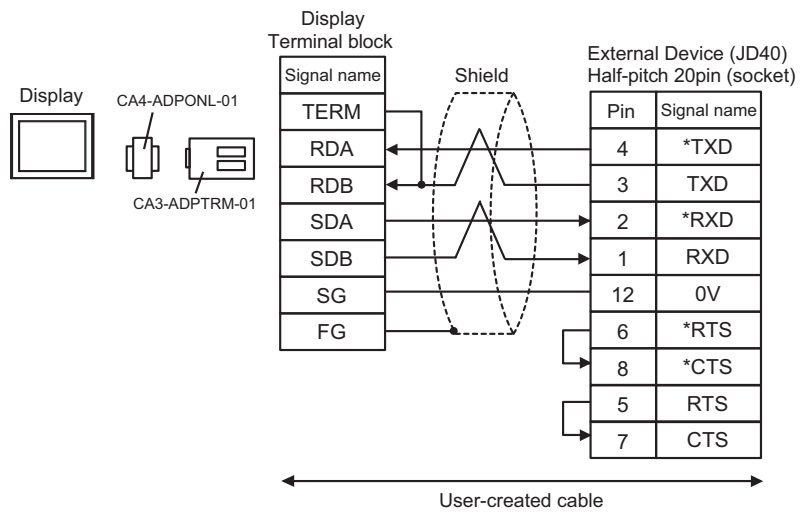
**NOTE**

- The cable length must be 1200m maximum.

4D)

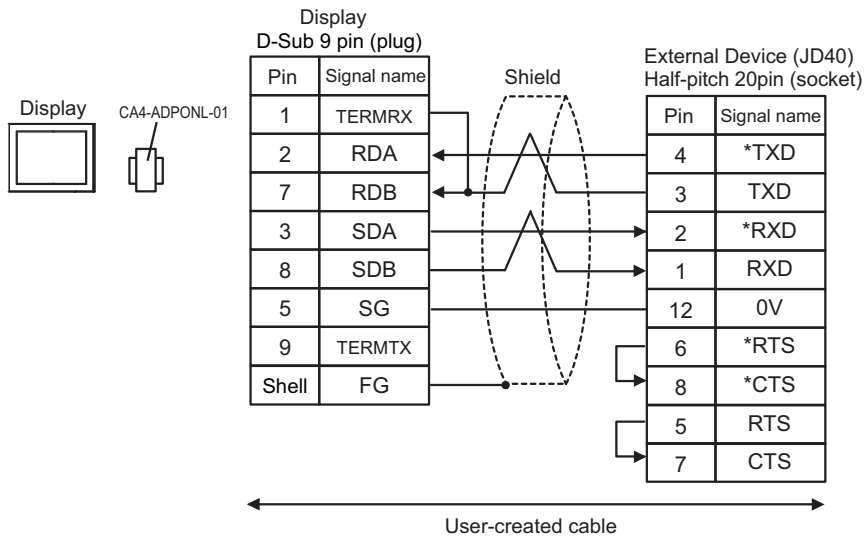
**NOTE**

- The cable length must be 1200m maximum.

4E)

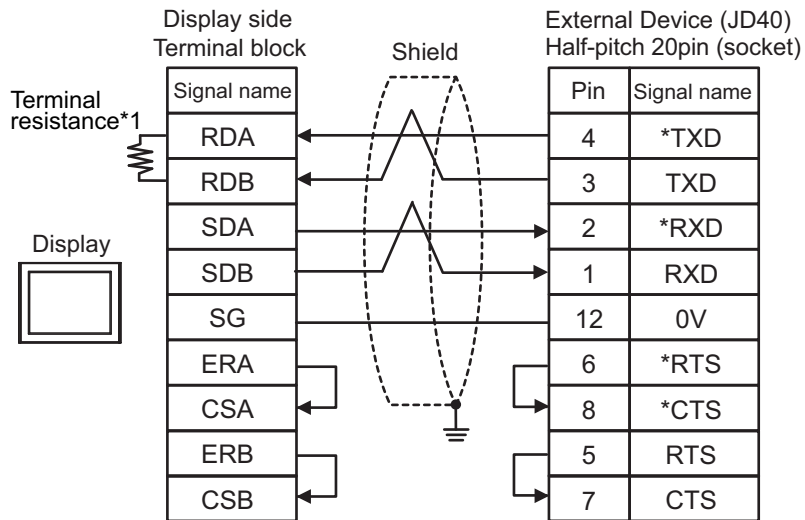

*1 The resistance in the Display is used as the termination resistance. Set the value of the DIP Switch on the rear of the Display as shown in the table below.

DIP Switch No.	Set Value
1	OFF
2	OFF
3	ON
4	ON

NOTE

- The cable length must be 1200m maximum.

4F)

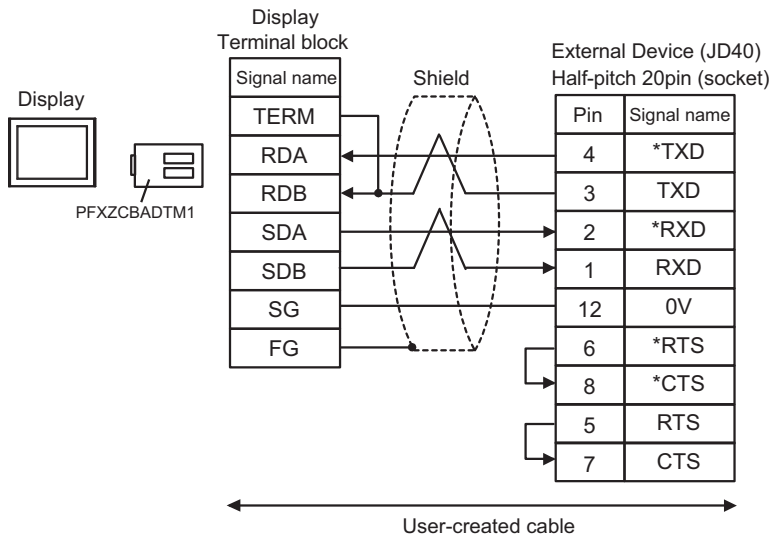
**NOTE**

- The cable length must be 1200m maximum.

4G)

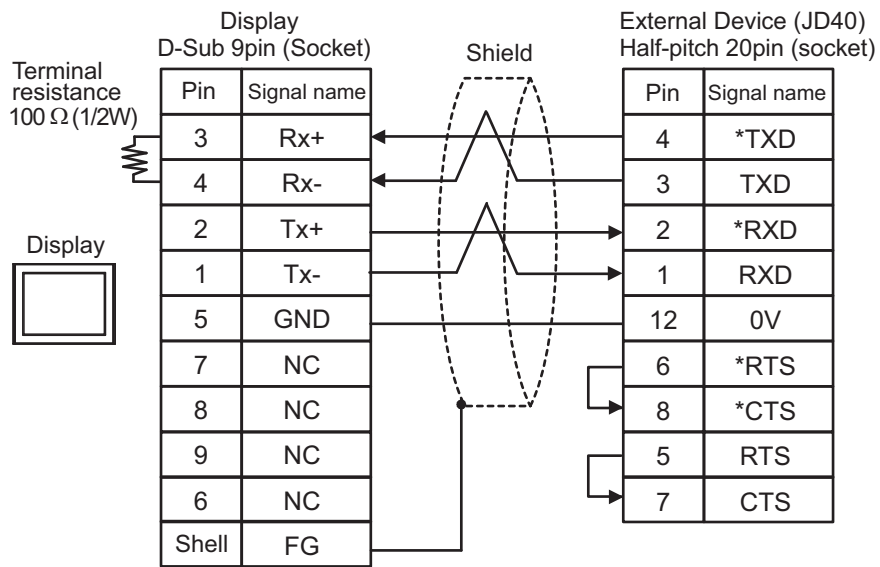
**NOTE**









- The cable length must be 1200m maximum.

6 Supported Device

Range of supported device address is shown in the table below. Please note that the actually supported range of the devices varies depending on the External Device to be used. Please check the actual range in the manual of your External Device.



6.1 Fanuc Power Mate Series

 This address can be specified as system data area.

Device	Bit Address	Word Address	32 bits	Notes
Input relay	X00000.0-X00127.7 X01000.0-X01063.7	X00000-X00126 X01000-X01062	[L/H]	
Output relay	Y00000.0-Y00127.7 Y01000.0-Y01063.7	Y00000-Y00126 Y01000-Y01062		
Internal relay	R00000.0-R00999.7	R00000-R00998		
Keep relay	K0000.0-K0019.7	K0000-K0018		
Timer	-----	T0000-T0078		
Counter	-----	C0000-C0078		
Data table	-----	D00000-D01858		  *1









*1 The maximum address available for bit access is D01859.7.

NOTE

- Please refer to the GP-Pro EX Reference Manual for system data area.
Cf. GP-Pro EX Reference Manual "LS Area (Direct Access Method Area)"
- Please refer to the precautions on manual notation for icons in the table.
 -  Supported Devices Symbol and Terms
- Please refer to the precautions on manual notation for icons in the table.
 -  "Manual Symbols and Terminology"

6.2 Fanuc Power Mate i Series

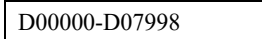
 This address can be specified as system data area.



Device	Bit Address	Word Address	32 bits	Notes
Input relay	X00000.0-X00127.7 X01000.0-X01003.7 X01020.0-X01051.7	X00000-X00126 X01000-X01002 X01020-X01050		
Output relay	Y00000.0-Y00127.7 Y01000.0-Y01002.7 Y01020.0-Y01051.7	Y00000-Y00126 Y01000 Y01020-Y01050		
Internal relay	R00000.0-R02999.7 R09000.0-R09199.7	R00000-R02998 R09000-R09198		 *1
Keep relay	K0000.0-K0039.7 K0900.0-K0909.7	K0000-K0038 K0900-K0908		 *2
Timer	-----	T0000-T0298		
Counter	-----	C0000-C0198		
Data table	-----	 D00000-D07998		 *3

*1 Bit Address "R09000.0-R09199.7" and Word Address "R09000-R09198" are the system control areas. Do not write the data in these addresses.

*2 Bit Address "K0900.0-K0909.7" and Word Address "K0900-K0908" are the system control areas. Do not write the data in these addresses.









*3 The maximum address available for bit access is D07999.7.

NOTE

- Please refer to the GP-Pro EX Reference Manual for system data area.
Cf. GP-Pro EX Reference Manual "LS Area (Direct Access Method Area)"
- Please refer to the precautions on manual notation for icons in the table.
 -  Supported Devices Symbol and Terms
- Please refer to the precautions on manual notation for icons in the table.
 -  "Manual Symbols and Terminology"

6.3 Fanuc Series (16-Model C / 18-Model C / 16i-Model A / 16i-Model B / 18i-Model A / 18i-Model B / 21i-Model A / 21i-Model B)

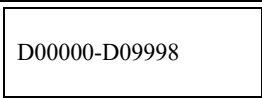

 This address can be specified as system data area.

Device	Bit Address	Word Address	32 bits	Notes
Input relay	X00000.0-X00127.7 X00200.0-X00327.7 X00400.0-X00527.7 X00600.0-X00727.7 X01000.0-X01127.7	X00000-X00126 X00200-X00326 X00400-X00526 X00600-X00726 X01000-X01126	[L/H]	 *1
Output relay	Y00000.0-Y00127.7 Y00200.0-Y00327.7 Y00400.0-Y00527.7 Y00600.0-Y00727.7 Y01000.0-Y01127.7	Y00000-Y00126 Y00200-Y00326 Y00400-Y00526 Y00600-Y00726 Y01000-Y01126		
Internal relay	R00000.0-R07999.7	R00000-R07998		
Keep relay	K00000.0-K00099.7	K0000-K00098		
Timer	-----	T0000-T0498		
Counter	-----	C0000-C0398 C5000-C5198		
Data table	-----	 D00000-D09998	  *2	

*1 Write disable

*2 The maximum address available for bit access is D09999.7.

NOTE

- Please refer to the GP-Pro EX Reference Manual for system data area.
Cf. GP-Pro EX Reference Manual "LS Area (Direct Access Method Area)"
- Please refer to the precautions on manual notation for icons in the table.
 -  Supported Devices Symbol and Terms
- Please refer to the precautions on manual notation for icons in the table.
 -  "Manual Symbols and Terminology"

6.4 Fanuc Series (30i-Model A / 31i-Model A / 32i-Model A)

 This address can be specified as system data area.

Device	Bit Address	Word Address	32 bits	Notes
Input relay	X00000.0-X00127.7 X00200.0-X00327.7 X00400.0-X00527.7 X00600.0-X00727.7 X01000.0-X01127.7	X00000-X00126 X00200-X00326 X00400-X00526 X00600-X00726 X01000-X01126	L/H	÷ 2 *1
Output relay	Y00000.0-Y00127.7 Y00200.0-Y00327.7 Y00400.0-Y00527.7 Y00600.0-Y00727.7 Y01000.0-Y01127.7	Y00000-Y00126 Y00200-Y00326 Y00400-Y00526 Y00600-Y00726 Y01000-Y01126		÷ 2
Internal relay	R00000.0-R07999.7	R00000-R07998		÷ 2
Keep relay	K00000.0-K00099.7	K0000-K00098		÷ 2
Enhancing Relay	E0000.0-E09999.7	E00000-E09998		÷ 2
Timer	-----	T0000-T0498		÷ 2
Counter	-----	C0000-C0398 C5000-C5198		÷ 2
Data table	-----	D00000-D09998		÷ 2 Bit 7 *2

*1 Write disable

*2 The maximum address available for bit access is D09999.7.

NOTE

- Please refer to the GP-Pro EX Reference Manual for system data area.
Cf. GP-Pro EX Reference Manual "LS Area (Direct Access Method Area)"
- Please refer to the precautions on manual notation for icons in the table.
 - ☞ Supported Devices Symbol and Terms
- Please refer to the precautions on manual notation for icons in the table.
 - ☞ "Manual Symbols and Terminology"

6.5 Fanuc Series (35i-Model B)

 This address can be specified as system data area.

Device	Bit Address	Word Address	32 bits	Notes
Input relay	X00000.0-X00127.7 X00200.0-X00327.7 X00400.0-X00527.7 X00600.0-X00727.7 X01000.0-X01127.7	X00000-X00126 X00200-X00326 X00400-X00526 X00600-X00726 X01000-X01126	L/H	÷ 2 *1
Output relay	Y00000.0-Y00127.7 Y00200.0-Y00327.7 Y00400.0-Y00527.7 Y00600.0-Y00727.7 Y01000.0-Y01127.7	Y00000-X00126 Y00200-Y00326 Y00400-Y00526 Y00600-Y00726 Y01000-X01126		÷ 2
Internal relay	R00000.0-R07999.7 R09000.0-R09499.7	R00000-R07998 R09000-R09498		÷ 2
Keep relay	K00000.0-K00099.7 K00900.0-K00999.7	K00000 -K00098 K00900 -K00998		÷ 2
Enhancing Relay	E0000.0-E09999.7	E00000-E09998		÷ 2
Timer	-----	T0000-T0498 T9000-T9498		÷ 2
Counter	-----	C0000-C0398 C5000-C5198		÷ 2
Data table	-----	D00000-D09998		÷ 2 Bit 7 *2

*1 Write disable

*2 The maximum address available for bit access is D09999.7.

NOTE

- Please refer to the GP-Pro EX Reference Manual for system data area.
Cf. GP-Pro EX Reference Manual "LS Area (Direct Access Method Area)"
- Please refer to the precautions on manual notation for icons in the table.
 - ☞ Supported Devices Symbol and Terms
- Please refer to the precautions on manual notation for icons in the table.
 - ☞ "Manual Symbols and Terminology"

7 Device Code and Address Code

Use device code and address code when you select "Device Type & Address" for the address type in data displays.

Device	Device Name	Device Code (HEX)	Address Code
Input relay	X	0080	Word address / 2
Output relay	Y	0081	Word address / 2
Internal relay	R	0082	Word address / 2
Keep relay	K	0083	Word address / 2
Enhancing Relay	E	0089	Word address / 2
Timer	T	0060	Word address / 2
Counter	C	0061	Word address / 2
Data table	D	0000	Word address / 2

8 Error Messages

Error messages are displayed on the screen of Display as follows: "No. : Device Name: Error Message (Error Occurrence Area)". Each description is shown below.

Item	Description
No.	Error No.
Device Name	Name of External Device where error occurs. Device name is a title of External Device set with GP-Pro EX. (Initial value [PLC1])
Error Message	Displays messages related to the error which occurs.
Error Occurrence Area	Displays IP address or device address of External Device where error occurs, or error codes received from External Device. <div style="border: 1px solid black; padding: 2px; margin: 5px 0;">NOTE</div> <ul style="list-style-type: none"> • IP address is displayed such as "IP address (Decimal): MAC address (Hex)". • Device address is displayed such as "Address: Device address". • Received error codes are displayed such as "Decimal [Hex]".

Display Examples of Error Messages

"RHAA036: PLC1: Error has been responded for device write command (Error Code: 2 [02H])"

NOTE

- Refer to your External Device manual for details on received error codes.
- Refer to "Display-related errors" in "Maintenance/Troubleshooting Guide" for details on the error messages common to the driver.

■ Error Message Peculiar to External Device

Message ID	Error Message	Description
RHxx128	(Node Name): Error has been responded for device read command (Major: [Hex], Minor: [Hex])	Error has been responded for device read command.
RHxx129	(Node Name): Error has been responded for device write command (Major: [Hex], Minor: [Hex])	Error has been responded for device write command.