

Pro-face

by Schneider Electric

GP3000H Conversion Adapter Installation Guide



Safety Information

Important Information	5
-----------------------------	---

Overview

Package Contents	7
About the Manual	7
Global Code	7

Part Names and Functions

Part Names and Functions	8
LED Indications	9

Specifications

Electrical Specifications	10
Environmental Specifications	11
Structural Specifications	12

Interface

Interface	13
Serial Interface	13
Ethernet Interface	14
24-Pole Terminal Block	15
Circuit Diagram of External Interface	19

Safety Circuit

Safety Circuit	22
----------------------	----

Dimensions

Dimensions	25
------------------	----

Installation

Installation to the panel	26
Installation and Removal from DIN rail	27

Connection

Connection with the Display Unit	29
--	----

Maintenance

Replacing the Installation Gasket	32
---	----

Cleaning this product 33

Standards

Standards..... 34

Important Information

Notice

Read these instructions carefully, and look at the equipment to become familiar with the device before trying to install, operate, or maintain it. The following special messages may appear throughout this documentation or on the equipment to warn of potential hazards or to call attention to information that clarifies or simplifies a procedure.



The addition of this symbol to a "Danger" or "Warning" safety label indicates that an electrical hazard exists which will result in personal injury if the instructions are not followed.



This is the safety alert symbol. It is used to alert you to potential personal injury hazards. Obey all safety messages that follow this symbol to avoid possible injury or death.

DANGER

DANGER indicates a hazardous situation which, if not avoided, **will result in** death or serious injury.

WARNING

WARNING indicates a hazardous situation which, if not avoided, **could result in** death or serious injury.

CAUTION

CAUTION indicates a hazardous situation which, if not avoided, **could result in** minor or moderate injury.

NOTICE

NOTICE is used to address practices not related to physical injury.

PLEASE NOTE

Electrical equipment should be installed, operated, serviced, and maintained only by qualified personnel. No responsibility is assumed by Pro-face for any consequences arising out of the use of this material.

A qualified person is one who has skills and knowledge related to the construction and operation of electrical equipment and its installation, and has received safety training to recognize and avoid the hazards involved.

If the equipment is used in a manner not specified by the manufacturer, the protection provided by the equipment may be impaired.

Product Related Information **DANGER****HAZARD OF ELECTRIC SHOCK, EXPLOSION OR ARC FLASH**

- Remove all power from the device prior to installing or removing this product and any cables.
- Use only the specified voltage when operating this product. This product designed to use 24 Vdc power. Always check whether your device is DC powered before applying power.
- Do not modify this product.

Failure to follow these instructions will result in death or serious injury.

 **CAUTION****EQUIPMENT DAMAGE**

Do not expose this product to direct sunlight.

Failure to follow these instructions can result in injury or equipment damage.

 **CAUTION****INOPERATIVE EQUIPMENT**

Do not allow water, liquids, and metal to contact this product.

Failure to follow these instructions can result in injury or equipment damage.

Unit Disposal

- When disposing this product, dispose it in a manner appropriate to, and in accordance with, your country's industrial machinery disposal/recycling standards.

Package Contents

The following items are included in the package. Before using this product, please confirm that all items listed here are present.

- 1 GP3000H Conversion Adapter (model number: AGP3000H-ADPCOM-01): 1
- 2 Installation Gasket: 1 (attached to this product)
- 3 Connector Cover: 1 (attached to this product)
- 4 M4 Screws (3 types): 4 of each type
- 5 Installation Guide (this guide): 1

This product has been carefully packed, with special attention to quality. However, should you find anything damaged or missing, please contact your local distributor immediately.

About the Manual

This document describes wiring and installation procedures.

For details on the display unit, refer to the corresponding hardware manual or installation guide that comes with this product.

You can download the manual from our support site at

<http://www.pro-face.com/trans/en/manual/1001.html>

NOTE: The original document is in English, the documents in the other languages are translations from the English.

Global Code

A global code is assigned to every Pro-face product as a universal model number.

For more information on product models and their matching global codes, please refer to the following URL.

<http://www.pro-face.com/trans/en/manual/1003.html>

Part Names and Functions

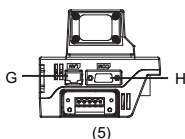

- 1: Front
- 2: Left Side
- 3: Rear
- 4: Right Side
- 5: Bottom

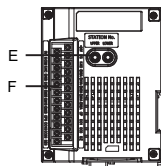
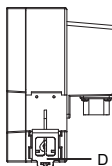
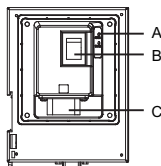
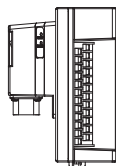

	Name	Description
A	LED	(see page 9)
B	Power switch	I: Power ON O: Power OFF
C	External interface	Connect the direct-connected cable (with connector) to the display unit. The connector cover is attached.
D	Hook	For mounting to a DIN rail (35 mm [1.38 in])
E	Rotary switch	Use the [UPPER] and [LOWER] rotary switches to set the ID number*1 for this product. The [UPPER] rotary switch sets digit 2 of the hexadecimal number, and the [LOWER] rotary switch sets digit 1 of the hexadecimal number, for an ID number range of 0 to 255 (00H to FFH). Example: For 95 (5FH), set the [UPPER] rotary switch to 5, and the [LOWER] rotary switch to F.
F	24-pole terminal block	Connect DOUT signals and other external outputs, power supply lines, etc. Customer to provide connection cable.
G	Ethernet interface	(see page 14)
H	Serial interface	(see page 13)

*1 Support of ID numbers, and how the ID number is used, differs depending on the screen editing software. For details, refer to your screen editing software manual.

LED Indications

POWER LED

Color	Indicaor	Status
Green	ON	Power is ON.
-	Not lit	Power is OFF.

STATUS LED

Color	Indicaor	Status
Green	ON	Connected with the display unit (Handshake established)
Orange	ON	Disconnected from the display unit (Handshake not established)
Red	ON	Communication error with the display unit. This product is reset.
-	Not lit	Power is OFF.

Electrical Specifications

Power supply	Rated input voltage	24 Vdc
	Input voltage limits	19.2...28.8 Vdc
	Voltage drop	10 ms or less
	Power consumption	6.3 W or less* ¹
	In-rush current	30 A or less
Voltage endurance	500 Vac, 20 mA for 1 minute (between charging and FG terminals)	
Insulation resistance	500 Vdc, 10 MΩ or more (between charging and FG terminals)	

*1 When the display unit is powered ON, the power consumption is the total of the display unit and this product.

Environmental Specifications

Physical environment	Surrounding air temperature	0...50 °C (32...122 °F) ^{*1}
	Storage temperature	-20...60 °C (-4...140 °F)
	Surrounding air and storage humidity	10...90% RH (non-condensing, wet bulb temperature 39 °C [102.2 °F] or less)
	Dust	0.1 mg/m ³ (10 ⁻⁷ oz/ft ³) or less (non-conductive levels)
	Pollution degree	For use in Pollution Degree 2 environment
	Corrosive gases	Free of corrosive gases
	Atmospheric pressure (operating altitude)	800...1,114 hPa (2,000 m [6,561 ft] or lower)
Mechanical environment	Vibration resistance	IEC/EN 61131-2 compliant 5...9 Hz single-amplitude 3.5 mm (0.14 in) 9...150 Hz fixed acceleration: 9.8 m/s ² X,Y,Z directions for 10 cycles (approx. 100 min.)
	Shock resistance	IEC/EN 61131-2 compliant 147 m/s ² , X, Y, Z directions for 3 times
Electrical environment	Noise immunity	Noise voltage: 1,000 Vp-p Pulse duration: 1 µs Rise time: 1 ns (via noise simulator)
	Electrostatic discharge immunity	Contact discharge method: 6 kV (IEC/EN 61000-4-2 Level 3)

*1 Surrounding air temperature of the display unit is 0 to 40 °C (32 to 104 °F).

Structural Specifications

Grounding	Functional grounding: Grounding resistance of 100 Ω , 2 mm ² (AWG 14) or thicker wire, or your country's applicable standard. (same for FG and SG terminals)
Structure	Rating: Equivalent to IP65F (When mounted to the panel) Installation configuration: 35 mm (1.38 in) DIN rail or panel mounted
Cooling method	Natural air circulation
Weight	600 g (1.32 lb) or less.
External dimensions (W x H x D)	113 x 144 x 100 mm (4.45 x 5.67 x 3.94 in)
Panel cut dimensions (W x H)	64.5 x 90.5 mm (2.54 x 3.56 in) ^{*1} Panel board thickness: 1.6...10.0 mm (0.06...0.39 in)

*1 For dimensional tolerance, everything +1/-0 mm (+0.04/-0 in) and R in angle are below R3 (R0.12 in).

Interface

Use only the SELV (Safety Extra-Low Voltage) circuit to connect the serial and Ethernet interfaces.

Serial Interface



ELECTRIC SHOCK AND FIRE

When using the SG terminal to connect an external device to this product:

- Verify that a short-circuit loop is not created when you set up the system.
- Connect the SG terminal to remote equipment when the external device is not isolated.
- Connect the SG terminal to a known reliable ground connection to reduce the risk of damaging the circuit.

Failure to follow these instructions will result in death or serious injury.

You can switch the communication method between RS-232C and RS-422/RS-485 via the software.

The serial interface is not isolated.

NOTE:

- For information on how to connect controllers and other types of equipment, refer to the corresponding device driver manual of your screen editing software.
- When isolation is necessary, you can use the RS-232C isolation unit (model number: CA3-ISO232-01) on the serial interface.

Asynchronous transmission	RS-232C/422/485
Data length	7 or 8 bits
Stop bit	1 or 2 bits
Parity	None, odd, or even
Data transmission speed	2,400...115,200 bps, 187,500 bps (MPI)
Maximum transmission distance* ¹	15 m (49.2 ft) (RS-232C), 1,200 m (3,937 ft) (RS-422, 115,200 bps)
Connector	D-Sub 9 pin (plug) x 1

*1 Includes length of connection cable between the display unit and this product.

Interface

Recommendations:

- Cable Connector: XM3D-0921 manufactured by OMRON Corporation
- Cable Cover: XM2S-0913 manufactured by OMRON Corporation.
- Jack Screw (#4-40 UNC): XM2Z-0073 manufactured by OMRON Corporation.

Pin #	RS-232C		RS-422/RS-485	
	Signal name	Description	Signal name	Description
1	CD	Carrier detect	RDA	Receive data A(+)
2	RD(RXD)	Receive data	RDB	Receive data B(-)
3	SD(TXD)	Send data	SDA	Send data A(+)
4	ER(DTR)	Data terminal ready	ERA	Data terminal ready A(+)
5	SG	Signal ground	SG	Signal ground
6	DR(DSR)	Data set ready	CSB	Clear to send B(-)
7	RS(RTS)	Request to send	SDB	Send data B(-)
8	CS(CTS)	Clear to send	CSA	Clear to send A(+)
9	CI(RI)/VCC	Called status display/+5V±5% output 0.25 A ^{*1}	ERB	Data terminal ready B(-)
Shell	FG	Frame ground (common with SG)	FG	Frame ground (common with SG)

*1 The RI/VCC selection for Pin #9 is switched via software. The VCC output is not protected against overcurrent. To prevent damage or unit malfunctions, use only the rated current.

Ethernet Interface

Standard	IEEE802.3u, 10BASE-T/100BASE-TX
Maximum transmission distance ^{*1}	100 m (328.1 ft)
Connector	Modular jack (RJ-45) x 1

*1 Includes length of the connection cable between the display unit and this product.

24-Pole Terminal Block

DANGER

HAZARD OF ELECTRIC SHOCK, EXPLOSION OR ARC FLASH

- Remove all power from the device prior to installing or removing this product and any cables.
- Always use terminal blocks covers on terminal blocks.

Failure to follow these instructions will result in death or serious injury.

CAUTION

EQUIPMENT DAMAGE

- Use the designated torque to tighten this product's terminal block screws.
- Remove this product from the panel before connecting cables with the terminal block.

Failure to follow these instructions can result in injury or equipment damage.

- Do not touch this product's contact terminals with your bare hands.
- When constructing your own cable, check the pin numbers indicated on the terminal block cover before wiring the cable.
- Wrap shield wires with tape or cover with insulation tubes.
- The tightening torque for terminal screws is 0.79 N·m [7.0 lb-in].
- Connect no more than 2 wires to each terminal.
- Normally, unplugging or plugging the direct-connected cable (with connector) from this product will trigger an emergency stop at the connected device. However, the cable can be plugged or unplugged without causing an emergency stop by providing an external safety circuit. Read the section, "Safety Circuit (see page 22)".

Interface

This product side	Pin No.	Signal name	Description
	1	DC24V	Power input 24 Vdc
	2	0V	Power input 0 Vdc
	3	FG	Functional ground (common with SG)
	4	KEY_COM* ¹	Key switch common. When this product's power on, 24 Vdc is output. Rating: 24 Vdc \pm 20%, 200 mA
	5	KEY_NO	Key switch (a-contact: normally open)
	6	KEY_NC	Key switch (b-contact: normally closed)
	7	ENB0A	3-position operation switch 0A (a-contact) Rating: 30 Vdc, 700 mA (Minimum applicable load: 3 Vdc, 5 mA)
	8	ENB0B	3-position operation switch 0B (a-contact)
	9	ENB1A	3-position operation switch 1A (a-contact) Rating: 30 Vdc, 700 mA (Minimum applicable load: 3 Vdc, 5 mA)
	10	ENB1B	3-position operation switch 1B (a-contact)
	11	EMG0A	Emergency stop switch / Stop switch 0A (a-contact) Rating: 30 Vdc, 1 A (Minimum applicable load: 5 Vdc, 1 mA)
	12	EMG0B	Emergency stop switch / Stop switch 0B (a-contact)
	13	EMG1A	Emergency stop switch / Stop switch 1A (b-contact) Rating: 30 Vdc, 1 A (Minimum applicable load: 5 Vdc, 1 mA)
	14	EMG1B	Emergency stop switch / Stop switch 1B (b-contact)
	15	EMG2A	Emergency stop switch / Stop switch 2A (b-contact) Rating: 30 Vdc, 1 A (Minimum applicable load: 5 Vdc, 1 mA)
	16	EMG2B	Emergency stop switch / Stop switch 2B (b-contact)
	17	OP	OP. output, open collector: 24 Vdc, 300 mA
	18	OP_GND	OP. ground
	19	DOUT1	DOUT1 output, open collector: 24 Vdc, 300 mA
	20	DOUT1_GND	DOUT1 ground
	21	DOUT0	DOUT0 output, open collector: 24 Vdc, 300 mA
	22	DOUT0_GND	DOUT0 ground
	23	BUZZ	Buzzer output, open collector: 24 Vdc, 300 mA
	24	BUZZER_GND	Buzzer ground

*1 [KEY_COM] terminal is used as a power source for the external safety circuit when developing the external safety circuit using display unit's Key Switch. When this product's power on, 24 Vdc is output. Do not connect pin #4 [KEY_COM] to touch any other terminals. For the details, "Safety Circuit (see page 22)".

Wiring terminals

Use crimp-type terminals that meet these conditions.

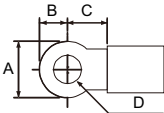
	A	6.0 mm (0.24 in) or less
	B	3.8 mm (0.15 in) or less
	C	5.2 mm (0.20 in) or more
	D	ϕ 3.2 mm (0.13 in) or more

Use crimp-type terminals with an insulated sleeve. Wrap with tape or cover with a tube if using non-insulated crimp-type terminals.

Power supply input

DC power cord preparation

- Use the thickest wire size possible (AWG 18 to AWG 14) and be sure to twist the wires from the ends.
- Use copper wire rated for 75 °C (167 °F).

Improving noise/surge resistance

- This product's power supply cord should not be bundled with or kept close to main circuit lines (high voltage, high current), power lines, or input/output lines, and their various systems should be kept separate. When power lines cannot be wired via a separate system, use shielded cables for input/output lines.
- Make the power cord as short as possible, and be sure to twist the ends of the wires together (i.e. twisted pair cabling) from close to the power supply unit.
- If there is an excess amount of noise on the power supply line, connect a noise reducing transistor before turning on the power.
- Connect a surge protection device to handle power surges.
- To increase noise resistance, attach a ferrite core to the power cable.

Power supply connections

- Use SELV (Safety Extra-Low Voltage) circuit and LIM (Limited Energy circuit) for DC input.
- The following shows a lightning surge absorber connection:

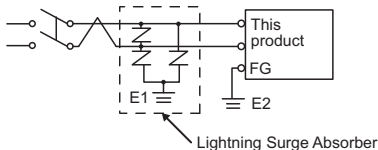

- Ground the surge absorber (E1) separately from this product (E2).
- Select a surge absorber that has a maximum circuit voltage greater than that of the peak voltage of the power supply.
- If the voltage variation is outside the prescribed range, connect a regulated power supply.
- Select a power supply low in noise for between the line and ground. If there is an excessive amount of noise, connect an insulating transformer. Use isolating transformers with capacities exceeding the maximum power consumption (see page 10).

Grounding

- Always ground the FG (functional ground) terminal.
- Check that the grounding resistance is 100Ω or less.*1
- The FG wire should have a cross sectional area greater than 2 mm^2 (AWG 14)*1. Create the connection point as close to this product as possible, and make the wire as short as possible. When using a long grounding wire, replace the thin wire with a thicker wire, and place it in a duct.

*1 Observe local codes and standards.

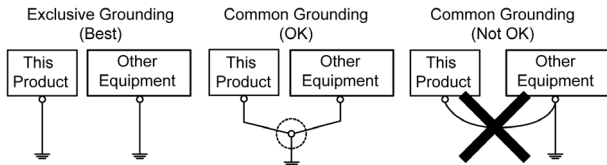

Short circuit prevention

- The SG (signal ground) and FG (functional ground) terminals are connected internally in this product. When connecting the SG line to another device, be sure that no shorting loops are formed.

Circuit Diagram of External Interface

DOUT output, Buzzer output

Sink Type

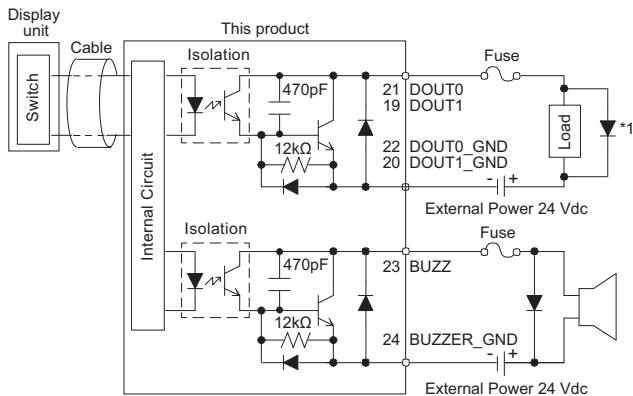

*1 When connecting inductive loads, provide surge protection on the load side.

Source Type

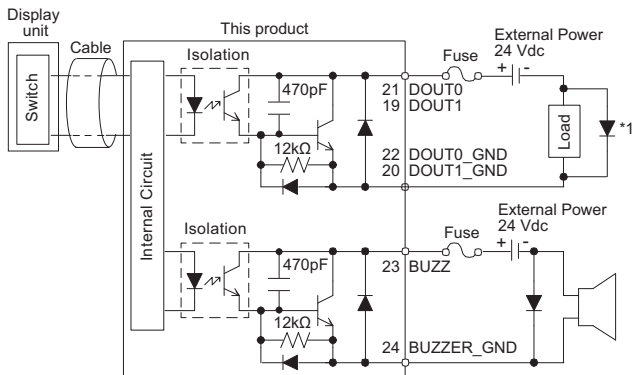

*1 When connecting inductive loads, provide surge protection on the load side.

Operation switch output

Sink Type

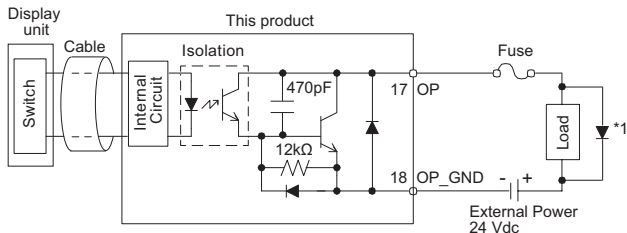

*1 When connecting inductive loads, provide surge protection on the load side.

Source Type

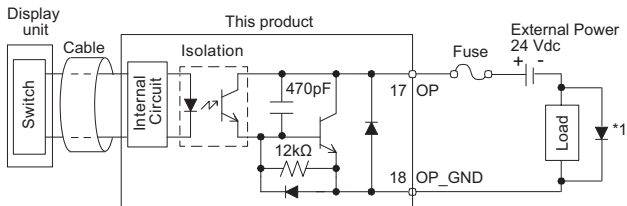

*1 When connecting inductive loads, provide surge protection on the load side.

3-Position enable switch output

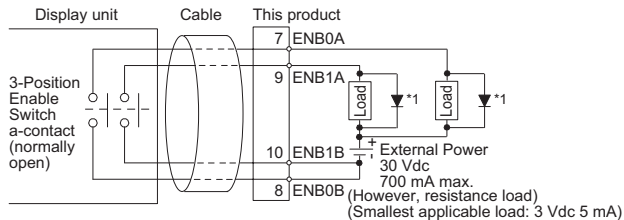

*1 When connecting inductive loads, provide surge protection on the load side.

Emergency stop switch / Stop switch output

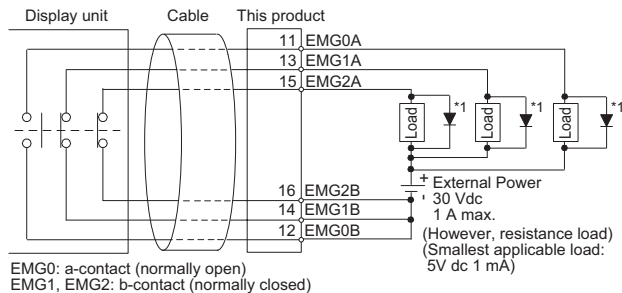

*1 When connecting inductive loads, provide surge protection on the load side.

Safety Circuit

Normally, unplugging and plugging the direct-connected cable (with connector) from this product will trigger an emergency stop at the connected device. By providing an external "safety circuit", the cable can be unplugged or plugged without triggering the emergency stop under the conditions described in the followings; "Conditions to Disable Emergency Stop When External Safety Circuit is Used". Read this section carefully.

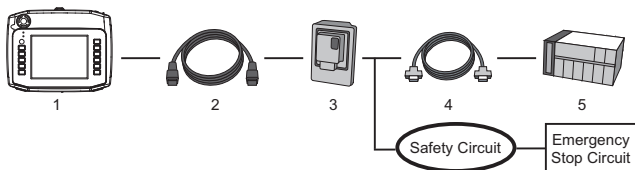

- 1 Display unit
- 2 Direct-connected cable (with connector)
- 3 This product
- 4 Connection cable (ex. RS-232C cable)
- 5 Host controller, PLC, etc.

- Connect all wires correctly and test the operation thoroughly after wiring is complete.
- If the several failures should be occurred at the same time such as the damage of the cables or display unit's Key Switch or relays to be deposited or failed to open, it may cause the safety feature deterioration. Be careful to use. The periodic checking of operations would be recommended.
- This safety circuit complies safety category 1 (ISO13849-1).

Recommended safe Relay	G7SA-2A2B <made by OMRON Corp.>	8 required
Recommended safe relay socket	P7SA-10F-ND <made by OMRON Corp.>	8 required
Diode	Reverse voltage greater than 250 Vdc, low forward voltage type recommended	4 required
Cable	AWG 26 (UL1061) recommended	
Power cord diameter	AWG 22 to 14 recommended	

a-contact: 33, 34, 43, 44

b-contact: 11, 12, 21, 22

□: Load

K1 to K8: Relay

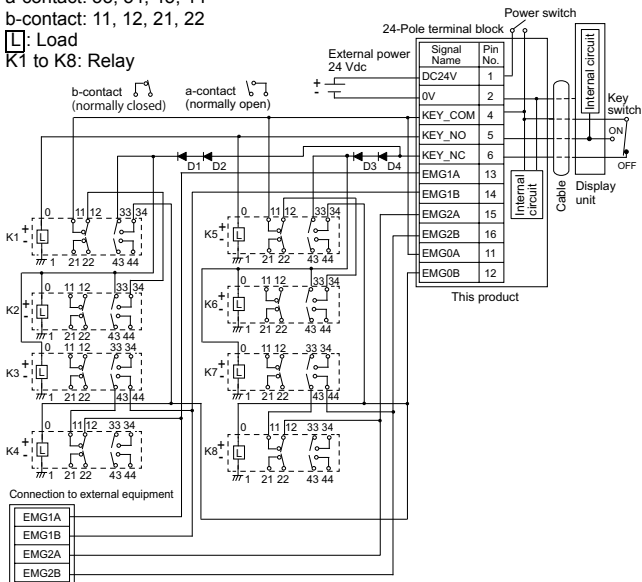

When turning this product ON, the terminal block pin #1 [DC24V (input)] and #4 [KEY_COM (24 Vdc output)] are connected internally. If pin #4 [KEY_COM] touches other terminals, especially pin #2 [0V] or pin #3 [FG], it will cause a short circuit and blow an internal fuse in this product. Do not connect pin #4 [KEY_COM] to touch any other terminals.

NOTE: When pin #4 (KEY_COM) is not in use, or when you use a display unit without a key switch, keep the pin terminal disconnected.

Conditions to Disable Emergency Stop When External Safety Circuit is Used

Under the following conditions, the emergency stop will not affect the connected device when the direct-connected cable is unplugged or plugged from this product.

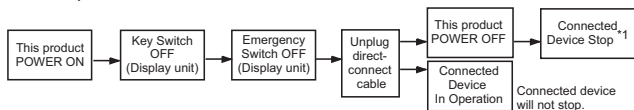

- *1 To disable the emergency stop, be sure to rewire #11 pins of the Relay K1 and K5 and [#11 EMG0A] of the 24-Pole Terminal Block in the above Security Circuit to [#1 DC24V]. Do not connect on [#4 KEY_COM].

Dimensions

NOTE: External view is shown using first angle projection method.

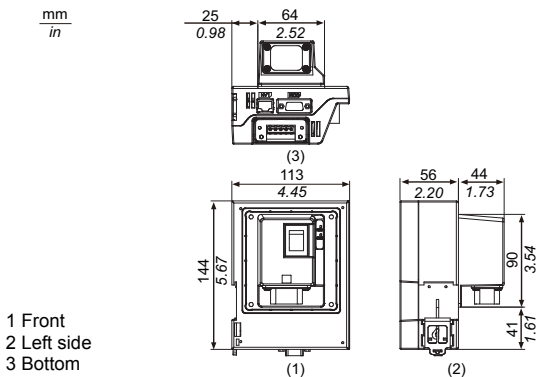

Cable Attached Dimensions

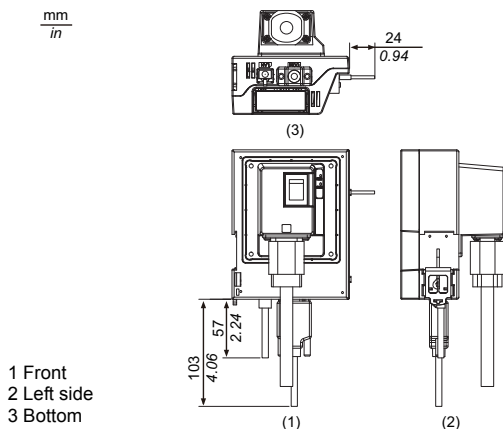

NOTE: All the above values are designed with cable bending in mind. The dimensions given here are representative values depending on the type of connection cable in use. Therefore, these values are intended for reference only.

Installation to the panel

This product is designed for use on flat surfaces of Type 1 Enclosure or IP65F. Be aware of the following when building this product into an end-use product:

- This product is approved as an open-type unit.
- This product is not designed for outdoor use. UL certification obtained is for indoor use only.
- Install this product in an enclosure with mechanical rigidity.
- This product's front surface is not approved as an enclosure. Therefore, provide a fireproof enclosure (metal barrier) that entirely covers this product's rear and lateral faces.

NOTE: IP65F is not part of the UL certification.

Panel cut dimensions

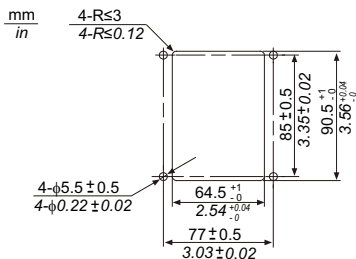

Step	Action
1	As shown in the illustration, confirm the location of the opening and four screw holes, then create installation holes on the panel.
2	Check that the installation gasket is seated securely into the gasket's groove, which runs around the perimeter of this product's frame. NOTE: Always use the installation gasket, since it absorbs vibration in addition to repelling water. For the procedure on replacing the installation gasket, refer to "Replacing the Installation Gasket (see page 32)".
3	Insert the front of this product through the panel from the rear.
4	Tighten the four M4 screws to attach this product. A torque of only 0.5 to 0.6 N·m (4.4 to 5.3 lb-in) is sufficient.

NOTE: The following shows the appropriate M4 screws to use for installation, depending on the panel thickness.

Panel thickness = t	Screws
$1.6 \leq t \leq 4.0$ mm (0.06 \leq t \leq 0.16 in)	M4 x 6
$4.0 < t < 8.0$ mm (0.16 < t < 0.31 in)	M4 x 12
$8.0 \leq t \leq 10.0$ mm (0.31 \leq t \leq 0.39 in)	M4 x 15

NOTICE

BROKEN ENCLOSURE

Do not exert more than 0.5 to 0.6 N•m (4.4 to 5.3 lb-in) of torque when tightening the screws.

Failure to follow these instructions can result in equipment damage.

Installation and Removal from DIN rail

Installation

Step	Action
1	Place this product's curved, top lip over the top of the DIN rail (35 mm [1.38 in]), and then tilt this product down until the bottom face DIN rail clip clicks into place.
2	Be sure to push and secure the hook in the direction indicated by the arrow.

1 DIN rail
2 Hook

Installation

NOTE:

- Be sure that the top and bottom faces of this product are facing the correct direction and this product is installed in a vertical position.
- The hook can be set to remain open. When attaching this product to the DIN rail, be sure the hook is completely closed and confirm that this product is held securely on the DIN rail.
- When attaching this product to a DIN rail, be sure to fix the cable in place so that the cable connected is supported and does not place a weight load on the connector.

Removal

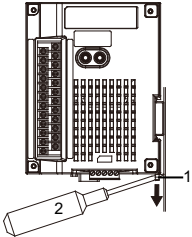
Step	Action
1	<p data-bbox="222 393 927 473">Use a slot screwdriver to force this product's hook down until the bottom of this product is freed from the rail. Next, tilt this product up and remove.</p>  <p data-bbox="222 793 429 844">1 Hook 2 Slot screwdriver</p>

Connection with the Display Unit

Prepare one of the following direct-connected cables (with connector) to connect with the display unit.

Model number	Description
GP3000H-CBLHD-10M	Hard-type cable. Heavy-duty type.
GP3000H-CBLSD-3M	Soft-type cable. Standard type.
GP3000H-CBLSD-5M	
GP3000H-CBLSD-10M	

▲ CAUTION

EQUIPMENT DAMAGE

Do not make the cable's connector fall down or hit it against something hard.

Failure to follow these instructions can result in injury or equipment damage.

Attaching the Direct-connected Cable

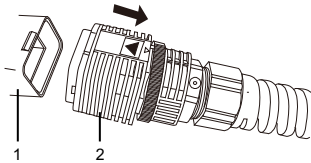
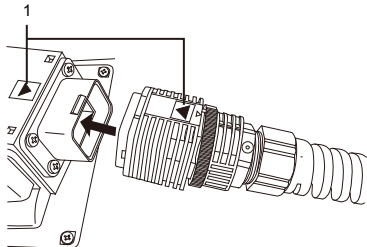
Step	Action
1	<p>Before connection, remove the cable's connector cap and this product's connector cover. To remove the cable's connector cap, pull out the cable by holding the cable connector.</p>  <p>1 Cable's connector cap 2 Cable connector</p> <p>NOTE: To disconnect this cable from the connector cap, be sure to hold the cable connector and pull it out. If you hold other parts of this cable (lock ring, etc.), the cable cannot be disconnected.</p>
2	<p>As illustrated, line up the arrow on this product with the arrow on the cable. Insert the cable's connector to this product's external interface until it clicks.</p>  <p>1 Arrows</p> <p>NOTE:</p> <ul style="list-style-type: none"> • Be sure to insert the cable connector as shown. • Connect the tagged end of the cable to this product, and the untagged end to the display unit.

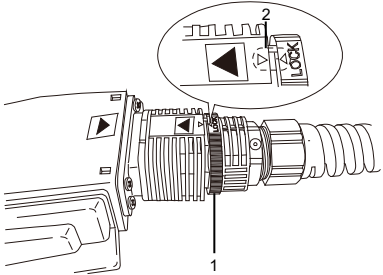
3	<p>Turn the cable connector lock ring to lock the connector, so that the small arrow (for LOCK) on the lock ring is aligned with the small arrow on the cable connector.</p>  <p>1 Lock ring 2 Small arrows</p>
---	--

Removing the Direct-connected Cable

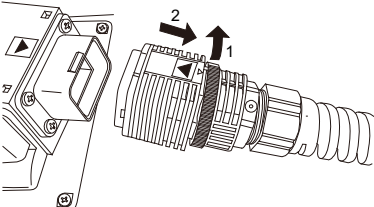
Step	Action
1	<p>Turn the lock ring so that the small arrow on the lock ring is displaced from the small arrow on the cable connector. Then, pull out the cable by holding the cable connector.</p>  <p>1 Turn the lock ring 2 Pull out the cable</p> <p>NOTE: To disconnect the cable, be sure to hold the cable connector and pull it out. If you hold other parts of the cable (lock ring, etc.), the cable cannot be disconnected.</p>

NOTE: Whenever the cable is removed, you cover the connector with a connector cover.

Replacing the Installation Gasket

The installation gasket provides protection against dust and moisture. Gaskets used for a long time, and gaskets detached from a panel, will not be water resistant if re-installed.

NOTICE

GASKET AGING

- Inspect the gasket periodically as required by your operating environment to keep the initial IP level.
- Change the gasket at least once a year, or as soon as scratches or dirt become visible.

Failure to follow these instructions can result in equipment damage.

Step	Action
1	Place this product on a flat, level surface facing the rear face downwards.
2	Remove the gasket from this product.
3	Be sure to insert the new gasket (model number: GP3000H-WPGADP-01) into this product's groove so that the gasket's groove sides are vertical. The upper surface of the gasket should protrude approximately 2.0 mm (0.08 in) out from the groove.

1 Gasket
2 Installation groove
3 Gasket seam

NOTE: The gasket must be inserted correctly into the groove for moisture resistance for this product.

▲ CAUTION**EQUIPMENT DAMAGE**

- Since the gasket is flexible but not elastic, be careful not to stretch it unnecessarily.
- Insert the gasket so the seam is at the bottom of this product. Do not insert the gasket's seam into any of the product's corners. Inserting the gasket seam into a corner may lead to its eventual tearing.

Failure to follow these instructions can result in injury or equipment damage.

Cleaning this product**NOTICE****EQUIPMENT DAMAGE**

- Power off this product before cleaning it.
- Do not use paint thinner, organic solvents, or a strong acid compound to clean the unit.

Failure to follow these instructions can result in equipment damage.

When this product gets dirty, soak a soft cloth in water with a neutral detergent, wring the cloth tightly and wipe this product.

Standards

The following unit is UL/c-UL listed product: (UL File No.E220851)

Registration Model No.	
AGP3000H-ADPCOM-01	3610006-01

For information on certifications and standards, such as certified models and certificates, see the product markings or the following URL:

<http://www.pro-face.com/trans/en/manual/1002.html>

Inquiry

Do you have any questions about difficulties with your unit?

Please access our site any time that you need help with a solution.

[**http://www.pro-face.com/trans/en/manual/1001.html**](http://www.pro-face.com/trans/en/manual/1001.html)

Note

Please be aware that Digital Electronics Corporation shall not be held liable by the user for any damages, losses, or third party claims arising from the uses of this product.

中国 RoHS 相关资料

(本资料是中国 RoHS 的必备资料。)
 (この情報は、中国 RoHS に対して必要な情報です。)
 (This information is essential for China RoHS.)

 部件名称 (Parts)	有毒有害物质或元素 (Toxic and Hazardous Substances or Elements)					
	铅 (Pb)	汞 (Hg)	镉 (Cd)	六价铬 (Cr6+)	多溴联苯 (PBB)	多溴二苯醚 (PBDE)
电子线路板 (Electronic board)	×	○	○	○	○	○
显示器 (LCD)	×	○	○	○	○	○
底座 & 罩盖 (Base & Cover)	○	○	○	○	○	○

本表格依据 SJ/T 11364 的规定编制。

This table is made according to SJ/T 11364.

○：表示该有毒有害物质在该部件所有均质材料中的含量均在 GB/T 26572 标准规定的限量要求以下。
 Indicates that the concentration of the hazardous substance in all homogeneous materials in the parts is below the relevant threshold of the GB/T 26572 standard.

×：表示该有毒有害物质至少在该部件的某一均质材料中的含量超出 GB/T 26572 标准规定的限量要求。
 Indicates that the concentration of the hazardous substance of at least one of all homogeneous materials in the parts is above the relevant threshold of the GB/T 26572 standard.

(企业可在此处，根据实际情况对上表中打“X”的技术原因进行进一步说明。)

(Corporate may provide further technical explanation to the 'X' in the table based on their own needs.)