

# GP-4201TM/4301TM/4000M

## Hardware Manual

GP42\_43TM-MM01-ENG-PDF\_L  
10/2020

---

The information provided in this documentation contains general descriptions and/or technical characteristics of the performance of the products contained herein. This documentation is not intended as a substitute for and is not to be used for determining suitability or reliability of these products for specific user applications. It is the duty of any such user or integrator to perform the appropriate and complete risk analysis, evaluation and testing of the products with respect to the relevant specific application or use thereof. Neither Schneider Electric nor any of its affiliates or subsidiaries (hereinafter, referred to as Schneider Electric) shall be responsible or liable for misuse of the information that is contained herein. If you have any suggestions for improvements or amendments or have found errors in this publication, please notify us.

You agree not to reproduce, other than for your own personal, noncommercial use, all or part of this document on any medium whatsoever without permission of Schneider Electric, given in writing. You also agree not to establish any hypertext links to this document or its content. Schneider Electric does not grant any right or license for the personal and noncommercial use of the document or its content, except for a non-exclusive license to consult it on an "as is" basis, at your own risk. All other rights are reserved.

All pertinent state, regional, and local safety regulations must be observed when installing and using this product. For reasons of safety and to help ensure compliance with documented system data, only the manufacturer should perform repairs to components.

When devices are used for applications with technical safety requirements, the relevant instructions must be followed.

Failure to use Schneider Electric software or approved software with our hardware products may result in injury, harm, or improper operating results.

Failure to observe this information can result in injury or equipment damage.

Copyright © 2019 Schneider Electric Japan Holdings Ltd. All Rights Reserved.

# Table of Contents



	<b>Safety Information</b> .....	<b>5</b>
	<b>About the Book</b> .....	<b>7</b>
<b>Chapter 1</b>	<b>General Overview</b> .....	<b>9</b>
	Package Contents .....	10
	Parts Identification and Functions .....	13
	Certifications and Standards .....	16
<b>Chapter 2</b>	<b>Device Connectivity</b> .....	<b>19</b>
	System Design .....	20
	Accessories .....	24
<b>Chapter 3</b>	<b>Specifications</b> .....	<b>27</b>
3.1	General Specifications .....	28
	General Specification .....	28
3.2	Functional Specifications .....	30
	Display .....	31
	Memory, Clock, and Touch Panel .....	32
3.3	Interface Specifications .....	33
	Interface Specifications .....	34
	Specifications of Serial Interface COM1 .....	35
3.4	Dimensions .....	37
	Display Module GP-4201TM .....	37
	Display Module GP-4301TM .....	38
	Rear Module (for all GP units) .....	39
	Display and Rear Modules GP-4201TM .....	40
	Display and Rear Modules GP-4301TM .....	41
	Cable Attached Dimensions .....	42
	Separation Cable Attached Dimension .....	43
	DIN Rail Attached Dimension .....	43
<b>Chapter 4</b>	<b>Installation and Wiring</b> .....	<b>45</b>
4.1	Installation .....	46
	Panel Cut-out Dimensions and Installation .....	47
	Installation Procedures .....	51
4.2	Wiring Principles .....	57
	Connecting the Power Cord .....	58
	Connecting the Power Supply .....	60
	Grounding .....	62
4.3	USB Interface .....	64
	Important Considerations When Using the USB interface .....	65
	USB Data Transfer Cable (ZC9USCBMB1) - USB Driver Installation .....	66
	USB (Type A) interface .....	67
	USB (mini-B) interface .....	70
<b>Chapter 5</b>	<b>Maintenance</b> .....	<b>73</b>
	Regular Cleaning .....	74

Periodic Check Points ..... 74  
After-sales service ..... 74

## Safety Information

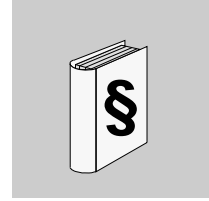

---

### Important Information

#### NOTICE

Read these instructions carefully, and look at the equipment to become familiar with the device before trying to install, operate, or maintain it. The following special messages may appear throughout this documentation or on the equipment to warn of potential hazards or to call attention to information that clarifies or simplifies a procedure.



The addition of this symbol to a Danger or Warning safety label indicates that an electrical hazard exists which will result in personal injury if the instructions are not followed.



This is the safety alert symbol. It is used to alert you to potential personal injury hazards. Obey all safety messages that follow this symbol to avoid possible injury or death.

### **DANGER**

**DANGER** indicates a hazardous situation which, if not avoided, will result in death or serious injury.

### **WARNING**

**WARNING** indicates a hazardous situation which, if not avoided, could result in death or serious injury.

### **CAUTION**

**CAUTION** indicates a hazardous situation which, if not avoided, could result in minor or moderate injury.

### **NOTICE**

**NOTICE** is used address practices not related to physical injury.

**PLEASE NOTE**

Electrical equipment should be installed, operated, serviced, and maintained only by qualified personnel. No responsibility is assumed by Schneider Electric for any consequences arising out of the use of this material.

A qualified person is one who has skills and knowledge related to the construction and operation of electrical equipment and the installation, and has received safety training to recognize and avoid the hazards involved.

## About the Book

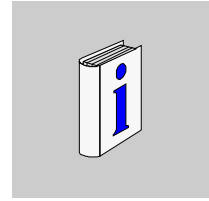

---

### At a Glance

Thank you for purchasing GP-4201TM/4301TM/4000M (Hereafter referred to as the "GP unit").

### Document Scope

This manual describes how to use the GP unit.

### Validity Note

This documentation is valid for the GP unit when used with GP-Pro EX version 4.02 or later.

The technical characteristics of the device(s) described in this manual appear online. To access this information online, please go to our site <http://www.pro-face.com/>.

The characteristics presented in this manual should be constantly improved for clarity and accuracy. In the event that you see a difference between the manual in your PC and online information, use the online information as your reference.

### Product Related Information

<b>⚠ WARNING</b>
<b>UNINTENDED EQUIPMENT OPERATION</b>
The application of this product requires expertise in the design and programming of control systems. Only persons with such expertise should be allowed to program, install, alter, and apply this product.
Follow all local and national safety codes and standards.
<b>Failure to follow these instructions can result in death, serious injury, or equipment damage.</b>

### Related Documents

Title of Documentation
GP-Pro EX Reference Manual
GP-Pro EX Device/PLC Connection Manual
GP-Pro EX Maintenance/Troubleshooting

You can download these technical publications and other technical information from our website at <http://www.pro-face.com/trans/en/manual/1001.html>.

**Model Name Indication**

Model name

**PFXGM4** <sup>\*</sup> <sup>\*\*</sup> <sup>\*</sup> **T** **A** **D**  
<sub>A</sub> <sub>B</sub> <sub>C</sub> <sub>D</sub> <sub>E</sub>

A	2	GP-4200 series (3.5-inch): QVGA (320 x 240 dots)
	3	GP-4300 series (5.7-inch): QVGA (320 x 240 dots)
	B	No display (Rear Module)
B	01	RS-232C/RS-422/RS-485
C	T	TFT color LCD
	-	No display (Rear Module)
D	A	Analog Touch Panel
	-	No display (Rear Module)
E	D	DC type power supply is used.

**GP-4201TM/4301TM/4000M Model Names**

	Series	Names	Models
GP4000 Series	GP-4200 Series	GP-4201TM (Modular Type)	PFXGM4201TAD
	GP-4300 Series	GP-4301TM (Modular Type)	PFXGM4301TAD
	GP-Rear Module	GP-4000M (Rear Modular Type)	PFXGM4B01D

**Global Code**

A global code is assigned to every Pro-face product as a universal model number. For more information on product models and their matching global codes, please refer to the following URL.

<http://www.pro-face.com/trans/en/manual/1003.html>



# General Overview



---

## Overview

This chapter describes the GP unit's General Overview.

## What's in this Chapter?

This chapter contains the following topics:

Topic	Page
Package Contents	10
Parts Identification and Functions	13
Certifications and Standards	16

## Package Contents

### Package Contents

Verify all items listed here are present in your package:

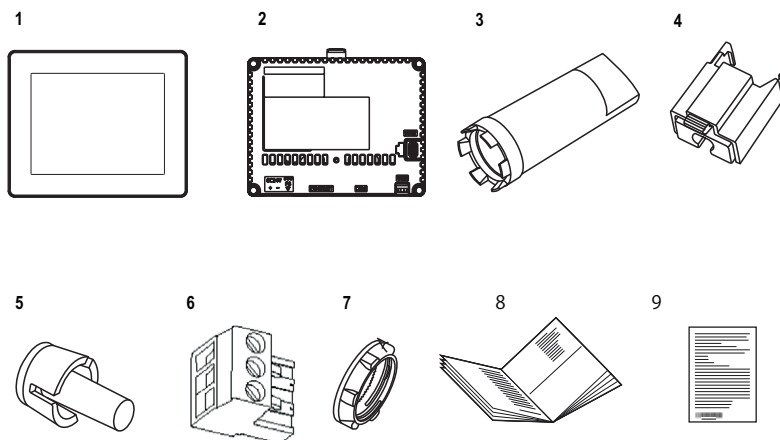

Legend	Description	Package Type		
		GP *1	Display Module	Rear Module
1	Display Module	Yes	Yes	No
2	Rear Module	Yes	No	Yes
3	Socket Wrench	Yes	No	No
4	USB Clamp Type A (1Port)	Yes	No	Yes
5	Anti-rotation Tee	Yes	Yes	No
6	DC Power Supply Connector	Yes	No	Yes
7	Display Installation Nut (Attached to the Display Module)	Yes	Yes	No
8	GP-4201TM/4301TM/4000M Installation Guide	Yes	Yes	Yes
9	Warning/Caution Information	Yes	Yes	Yes

\*1. Display Module and Rear Module

### Product Label Sticker

You can identify the product version (PV), revision level (RL) and software version (SV) from the product label.

The following diagram is a representation of a typical label:

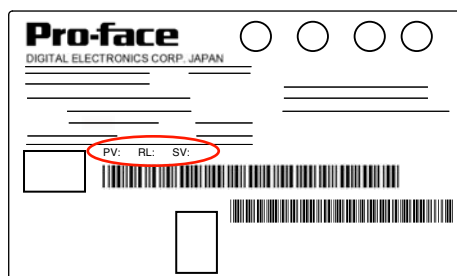

When PV is 03 or later and SV is 3.0 or later, GP can also be used as a rear module.

### Critical systems, Detected Alarms and Handling Requirements

Critical detected alarm indicators and system functions require independent and redundant protection hardware and/or mechanical interlocks.

If the unit for any reason becomes inoperative (for example, an inoperative backlight) it may be difficult or impossible to identify a function. Functions that may present a hazard if not immediately executed, such as emergency stop, must be provided independently of the unit. The design of the control system must take into account an inoperative unit (backlight) and that the operator is unable to control the machine or respond to detected errors using the unit.

When the power is cycled, wait at least 10 seconds before restoring the power to the GP Unit. Switching the power OFF and ON quickly can damage the unit.

#### **WARNING**

##### **LOSS OF CONTROL**

- Consider the potential failure modes of control paths in the machine control system design, such as:
  - The possibility of backlight failure,
  - Unanticipated link transmission delays or failures,
  - The operator being unable to control the machine,
  - The operator making errors in the control of the machine.
- Provide a means to achieve a safe state during and after a path failure for critical control functions such as emergency stop and overtravel stop.
- Provide separate or redundant control paths for critical control functions.
- Test individually and thoroughly each implementation of the GP unit for correct operation before service.

**Failure to follow these instructions can result in death, serious injury, or equipment damage.**

#### **WARNING**

##### **UNINTENDED EQUIPMENT OPERATION**

- Do not use the unit as the only means of control for critical system functions such as motor start/stop or power control.
- Do not use the unit as the only notification device for critical alarms, such as device overheating or overcurrent.

**Failure to follow these instructions can result in death, serious injury, or equipment damage.**

## Handling the LCD Panel

The following characteristics are specific to the LCD unit and are considered normal behavior:

- LCD screen may show unevenness in the brightness of certain images or may appear different when seen from outside the specified viewing angle. Extended shadows, or cross-talk, may also appear on the sides of screen images.
- LCD screen pixels may contain black and white colored spots and color display may seem to have changed over time.
- When the same image is displayed on the screen for a long period, an after-image may appear when the image is changed.

**NOTE:** Do not display the same image for a long time, change the screen image periodically.

### CAUTION

#### SERIOUS EYE AND SKIN INJURY

The liquid present in the LCD panel contains an irritant:

- Avoid direct skin contact with the liquid.
- Wear gloves when you handle a broken or leaking unit.
- Do not use sharp objects or tools in the vicinity of the LCD touch panel.
- Handle the LCD panel carefully to prevent puncture, bursting, or cracking of the panel material.

If the panel is damaged and any liquid comes in contact with your skin, immediately rinse the area with running water for at least 15 min.

If the liquid gets in your eyes, immediately rinse your eyes with running water for at least 15 minutes and consult a doctor.

**Failure to follow these instructions can result in injury or equipment damage.**

## Using Touch Panel Correctly

### WARNING

#### UNINTENDED EQUIPMENT OPERATION

- Operate the GP unit touch panel with only one finger.
- Do not activate two or more points of the touch panel simultaneously.

**Failure to follow these instructions can result in death, serious injury, or equipment damage.**

Use only one finger to select an object on the touch panel.

If the touch panel receives pressure at two or more points at the same time, an unintended object could be selected.

## Cybersecurity Best Practices

To help keep your Pro-face products secure and protected, we recommend that you implement the cybersecurity best practices. Following the recommendations may help significantly reduce your company's cybersecurity risk. For the recommendations, refer to the following URL:

<https://www.pro-face.com/trans/en/manual/1087.html>

## Parts Identification and Functions

### Display Module

Front:

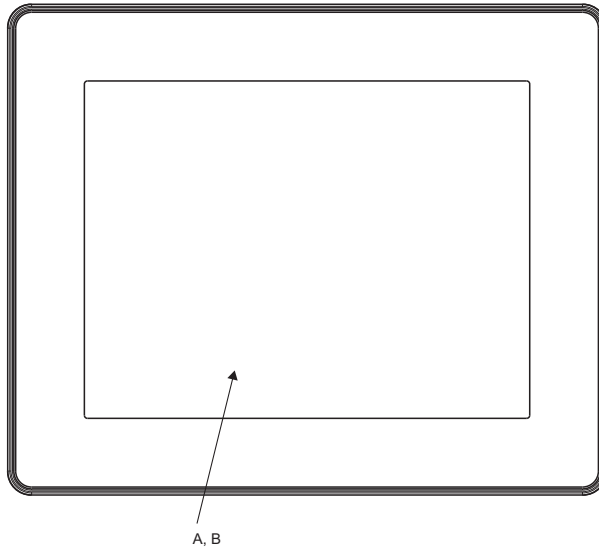

- A** Display: displays user created screens and remote equipment variables.
- B** Touch panel: performs screen change operations and sends data to the host (PLC).

Rear:

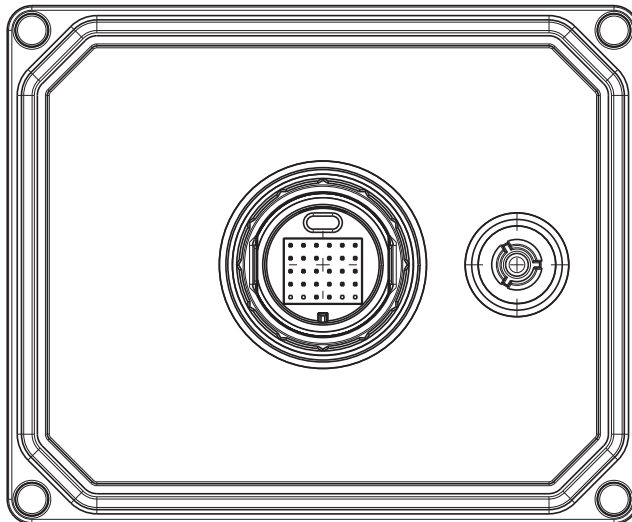

Rear Module

Front:

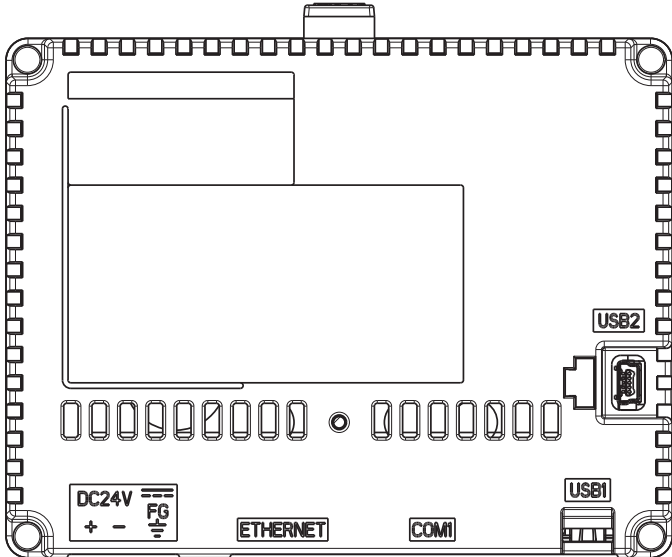

Rear:

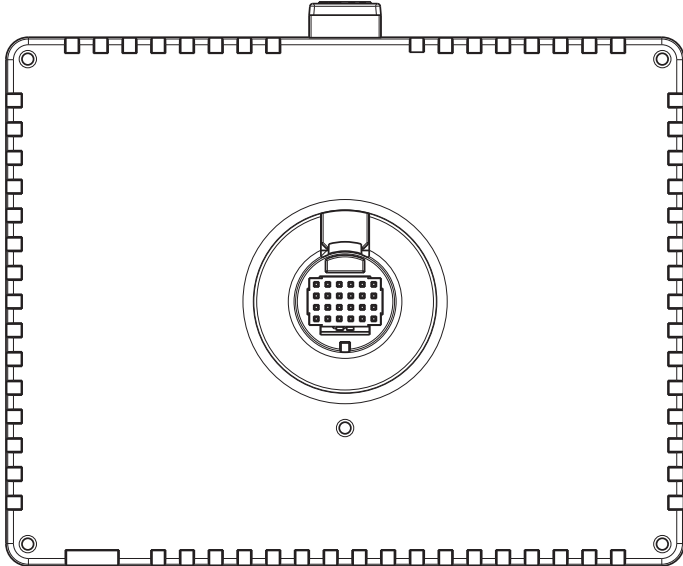

**Connectors:**

Bottom:

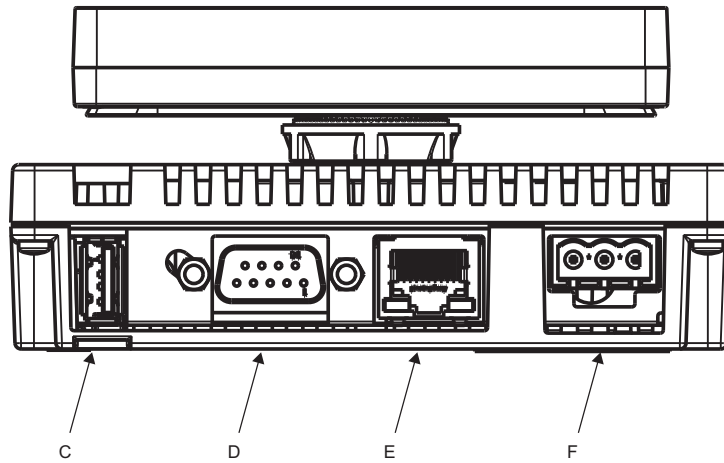

- C** USB (Type A) interface connector: connects the memory stick to the unit.
- D** Serial I/F (host I/F): connects a RS232C/RS422/RS485 cable (from the host/PLC) to the GP unit. D-Sub 9-pin plug type connector.
- E** Ethernet Interface (LAN): connects an Ethernet cable (from the host/PLC) to the unit.
- F** DC Power Supply Connector: connects the power input and ground wires to the unit.

Side:

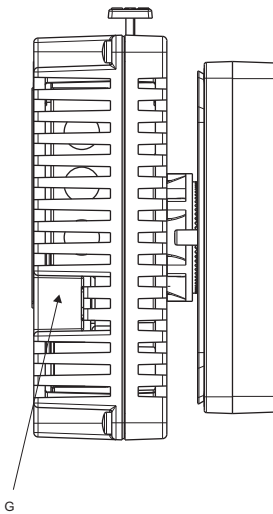

- G** USB (mini-B) interface connector: connects the data transfer PC cable to the unit.

## Certifications and Standards

### Introduction

Schneider Electric submitted this product for independent testing and qualification by third-party listing agencies. These agencies have certified this product as meeting the following standards.

For information on Standards and Regulations, such as certified models and certificates, see the following.

*<http://www.pro-face.com/trans/en/manual/1002.html>*

### Agency Certifications for GP Unit

GP unit is certified by the Underwriters Laboratory according to:

- UL 508 and CSA C22.2 n°142 for Industrial Control Equipment
- ANSI/ISA 12.12.01 and CSA C22.2 n°213 for Electrical Equipment for Use in Class I, Division 2 Groups A, B, C and D Hazardous (classified) Locations

**NOTE:**

- For use in Pollution Degree 2 environments.
- For use on a flat surface of Type 4X Enclosure.

### Hazardous Substances

GP unit is designed for compliance with:

- WEEE, Directive 2012/19/EU
- RoHS, Directive 2011/65/EU and 2015/863/EU
- RoHS China, Standard (GB/T 26572)



### UL Conditions of Acceptability and Handling Cautions for GP Unit

The GP unit is suitable for use in hazardous locations in accordance with Class I, Division 2 Groups A, B, C and D standards. All relevant local, state, and regional codes must be followed.

## **WARNING**

### **RISK OF EXPLOSION IN HAZARDOUS LOCATIONS**

- Verify that the power, input and output (I/O) wiring are in accordance with Class I, Division 2 wiring methods.
- Substitution of any components may impair suitability for Class I, Division 2.
- Do not disconnect equipment unless power has been switched off or the area is known to be Non-Hazardous.
- Securely lock externally connected units and each interface before turning on the power supply.
- Do not disconnect while circuit is live unless area is known to be Non-Hazardous.
- USB mini-B connector is for temporary connection only. Do not use, connect, or disconnect unless area is known to be non-hazardous. Connection or disconnection in an explosive atmosphere could result in an explosion.
- Potential electrostatic charging hazard: wipe the front panel of the terminal with a damp cloth before turning ON.
- Do not substitute a rear module labeled GP-4201TM/4301TM by a rear module labeled PFXGM4B01D when installed in Hazardous Locations.

**Failure to follow these instructions can result in death, serious injury, or equipment damage.**

**CE Markings**

This product conforms to the necessary requirements of the following Directives for applying the CE label:

- Directive 2014/35/EU (Low Voltage)
- Directive 2014/30/EU (EMC)

This conformity is based on compliance with EN 61131-2.

**KC Markings**사용자안내문

기종별	사 용 자 안 내 문
A급 기기 (업무용 방송통신기자재)	이 기기는 업무용(A급) 전자파적합기기로서 판매자 또는 사용자는 이 점을 주의하시기 바라며, 가정외의 지역에서 사용하는 것을 목적으로 합니다.

# Device Connectivity

# 2

---

## Introduction

This chapter presents the equipment connectable to GP unit.

## What's in this Chapter?

This chapter contains the following topics:

Topic	Page
System Design	20
Accessories	24

# System Design

## Introduction

The following diagrams represent equipment that can be connected to the unit.

## RUN Mode Peripherals - Serial Communication

NOTE:

For instructions on how to connect to other devices, always refer to the “GP-Pro EX Device/PLC Connection Manual”.

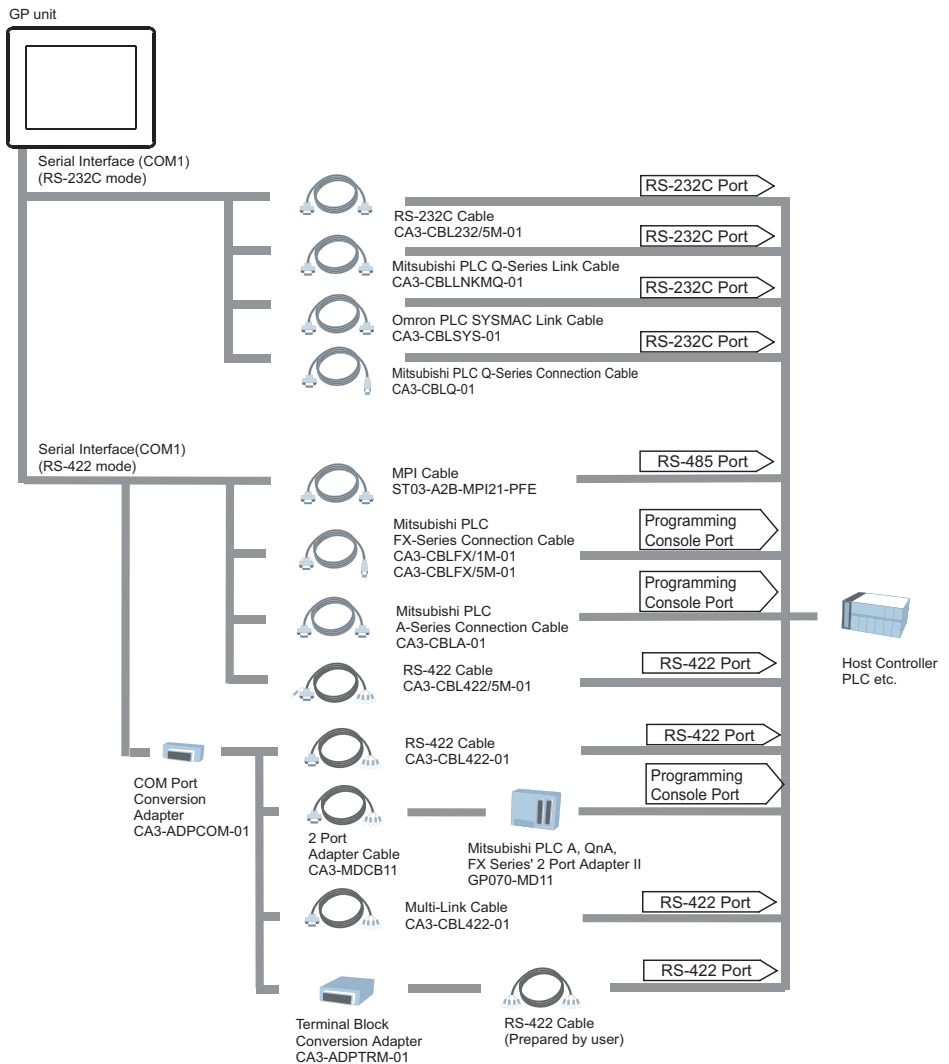

## RUN Mode Peripherals - Ethernet Communication

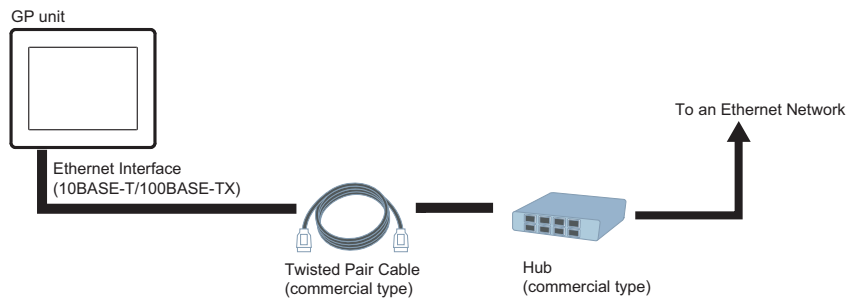

## RUN Mode Peripherals - USB Interface

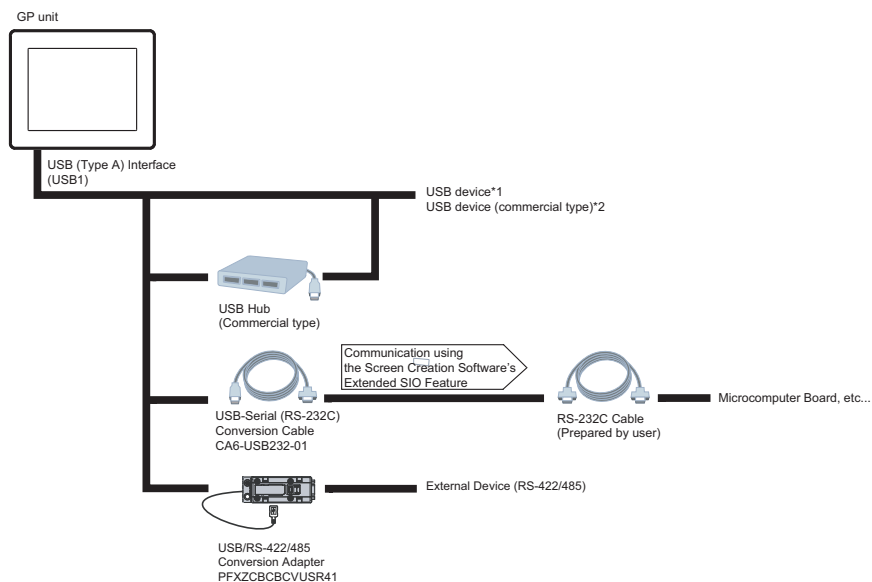

\*1 Refer to the System Design (see page 20)

\*2 For supported models, refer to our support site (<http://www.pro-face.com/trans/en/manual/1001.html>).

You can connect to this site by clicking the GP-Pro EX's [Help (H)] menu-[Connect to Support Site "Otasuke Pro!" (C)] command.

### **CAUTION**

#### **GP UNIT RESET**

- If connecting a bus-powered bar code reader or EZ Illuminated Switch and so on to the GP unit, be sure to supply power from an external source (such as a self-powered hub). If you supply power from the GP unit, the GP unit may reset itself because the GP unit cannot supply enough power.

**Failure to follow these instructions can result in injury or equipment damage.**

## Edit Mode Peripherals

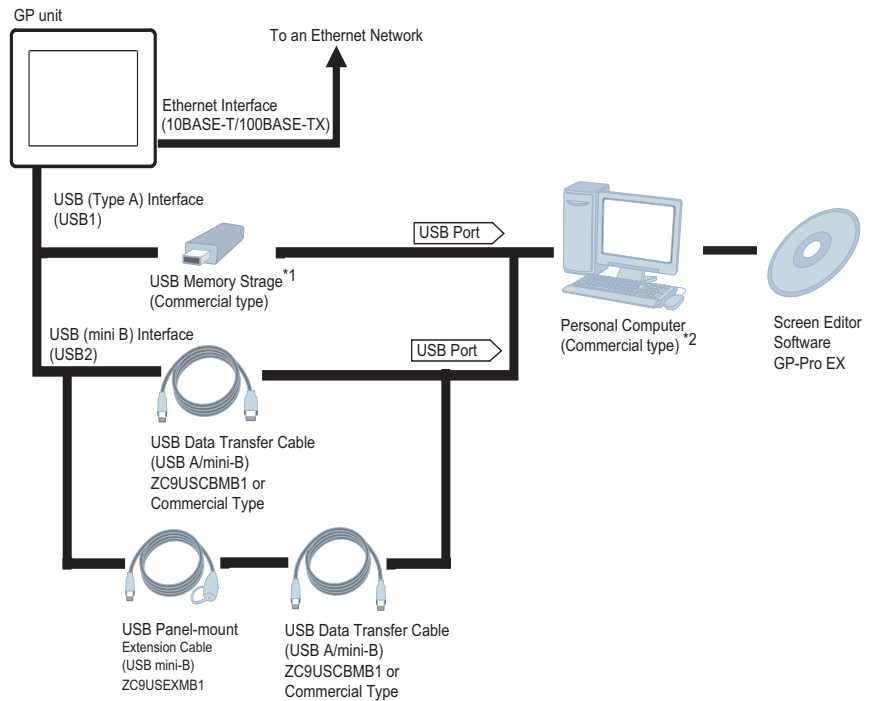

\*1 For supported models, refer to our support site (<http://www.pro-face.com/trans/en/manual/1001.html>).

You can connect to this site by clicking the GP-Pro EX's [Help (H)] menu-[Connect to Support Site "Otasuke Pro!" (C)] command.

\*2 Certain types and models of PCs cannot be used. Refer to GP-Pro EX Reference Manual.

## Accessories

### Serial Interface Item

Product Name	Model No.	Description
RS-232C Cable (5m)	CA3-CBL232/5M-01	Connects a host controller to the GP unit. (RS-232C)
RS-422 Cable (5m)	CA3-CBL422/5M-01	Connects a host controller to the GP unit. (RS-422 / Socket Type)
Mitsubishi PLC Q-Series Link Cable (5m)	CA3-CBLLNKM-01	Connects Mitsubishi PLC Q-Series (or other host controller) to the GP unit. (RS-232C)
Omron PLC SYSMAC Link Cable (5m)	CA3-CBLSYS-01	Connects Omron PLC SYSMAC Series unit (or other host controller) to the GP unit. (RS-232C)
Mitsubishi PLC A-Series Connection Cable (5m)	CA3-CBLA-01	Connects Mitsubishi PLC A, QnA Series programming console I/F to GP unit. (Simultaneous use of programming console is not possible.)
Mitsubishi PLC Q-Series Connection Cable (5m)	CA3-CBLQ-01	Connects Mitsubishi PLC Q-Series programming console I/F to GP unit. (Simultaneous use of programming console is not possible.)
Mitsubishi PLC FX-Series Connection Cable	CA3-CBLFX/1M-01 (1m) CA3-CBLFX/5M-01 (5m)	Connects Mitsubishi PLC FX-Series programming console I/F and GP unit. (Simultaneous use of programming console is not possible.)
RS-422 Cable (5m)	CA3-CBL422-01	Connects a host controller to the GP unit. (RS-422 / Plug Type)
2 Port Adapter Cable (5m)	CA3-MDCB11	Connects Mitsubishi PLC to the GP unit using 2 port adapter II (RS-422).
Mitsubishi PLC A, QnA, FX Series 2 Port Adapter II	GP070-MD11	Allows simultaneous use of an GP unit Series unit and a Mitsubishi PLC A, QnA, FX Series peripheral device.
Terminal Block Conversion Adapter	CA3-ADPTRM-01	Connects output from a serial interface with an RS-422 terminal block.
COM Port Conversion Adapter	CA3-ADPCOM-01	Connects optional RS-422 communication items to GP unit's COM1 port.
Multi-Link Cable	CA3-CBLMLT-01 (5m)	Connects a host controller to the GP for multi-link (n:1) communication.
9-pin-to-25-pin RS-232C Conversion Cable	CA3-CBLCBT232-01 (0.2m)	Connects a standard RS-232C cable (GP Connector, D-Sub 25-pin) to the GP.
9-pin-to-25-pin RS-422 Conversion Cable	CA3-CBLCBT422-01 (0.2m)	Connects a standard RS-422 cable (GP Connector, D-Sub 25-pin) to the GP.
MPI Cable (3.5m)	ST03-A2B-MPI21-PFE	Connects a host controller to the GP unit for MPI communication.



**USB Interface Item**

<b>Product Name</b>	<b>Model No.</b>	<b>Description</b>
USB Front Cable (1m)	CA5-USBEXT-01	Extension cable attaching USB interface to front panel.
USB-Serial (RS-232C) Conversion Cable (0.5m)	CA6-USB232-01	Cable for converting a GP unit's USB interface into a serial interface (RS-232C). Can be used to transfer project data created with the Screen Editor&Logic Program Software via a serial interface.*1
USB Transfer Cable (USB Type A/mini-B) (1.8 m)	ZC9USCBMB1	Cable for transferring screen data from a PC (USB Type A) to the GP unit (USB mini-B).
USB Panel-mount Extension Cable (USB mini-B) (1 m)	ZC9USEXMB1	Extension cable attaching to the USB (mini-B) interface on the front side of the operation panel.
USB/RS-422/485 Conversion Adapter	PFXZCBCBCVUSR41	Adapter for connecting this product (USB Type A) to an external device (RS-422/RS-485).
EZ Illuminated Switch	PFXZCCEUSG1	A unit of 5 illuminated switches with multiple color LED easily connected with GP unit via USB.
EZ Fingerprint Recognition Unit	PFXZCCEUSS1	Fingerprint recognition unit easily connected with GP unit via USB.
EZ Tower Light tube mounting with fixing plate	PFXZCETWHA1	USB Connection Type Monolithic EZ Tower Light tube mounting with fixing plate 3 tiers, É"60, lighting and flashing with a buzzer.
EZ Tower Light with base mounting	PFXZCETWW1	USB Connection Type Monolithic EZ Tower with base mounting 3 tiers, É"60, lighting and flashing with a buzzer.
EZ Numpad	PFXZCCEUKB1	Numpad connected to this product via USB.

\*1 Requires an RS-232C cable (prepared by user) for connection. For details regarding system design, refer to "RUN Mode Peripherals - USB Interface" (page 22).

## Option Items

Product Name	Model No.	Description
3.5 inch Screen Protection Sheet	CA6-DFS4-01	Disposable, dirt-resistant sheet for the GP unit's screen. (5 sheets/set) (Hard type)
5.7 inch Screen Protection Sheet	PFXZCBDS61	
3.5 inch UV Protection Sheet	PFXZCFUV41	Sheet to protect the display from dirt and ultraviolet light (1 piece)
5.7 inch UV Protection Sheet	PFXZCFUV61	
3.5 inch display module	PFXXM4200TP	Display module for GP4000 Series
5.7 inch display module	PFXXM4300TP	
Display module/Rear module separation cable (3m)	PFXZXMADSM31	Cable with hook to install a rear module on a DIN rail while connecting the rear module to a separated display module. *1
Display module/Rear module separation cable (5m)	PFXZXMADSM51	
Rear module installation adapter	PFXZXMADSA1	DIN rail installation adapter for rear modules in non-display operation.

\*1Available for the product which meets the requirements below.

Names	PV	RL	SV
GP-4201TM (Modular Type)	03 or later	07 or later	4.0 or later
GP-4301TM (Modular Type)	03 or later	08 or later	4.0 or later
GP-4000M (Rear Modular Type)	All revisions		

You can identify the product version (PV), revision level (RL) and software version (SV) from the Product Label Sticker (page 10).

## Maintenance Items

Product Name	Model No.	Description
Display Installation Nut	PFXZGMNT1	Nut to install the display module (10 pcs/set)
Socket Wrench	PFXZGMSW1	Socket wrench to tighten and loosen the display installation nut
Accessories Kit	PFXZGMAK1	Anti-rotation Tee, USB cable clamp to prevent disconnection (Type A, Mini-B, for 1 port), 2mm-high spacer to adjust installation panel thickness (1pcs/each)
DC Power Supply Connector	PFXZGMCNDC1	Connector to connect DC power supply cables (5 pcs/set)

# Specifications

# 3

---

## Overview

This chapter presents the GP unit specifications.

## What's in this Chapter?

This chapter contains the following sections:

Section	Topic	Page
3.1	General Specifications	28
3.2	Functional Specifications	30
3.3	Interface Specifications	33
3.4	Dimensions	37

## 3.1 General Specifications

### General Specification

#### Electrical Specifications

	Rated Input Voltage	Input Voltage Limits	Voltage Drop	Power Consumption	In-Rush Current	Voltage Endurance	Insulation Resistance
GP-4201TM	24 Vdc *1	20.4...28.8 Vdc	10 ms or less	6.8 W or less *2	30 A or less	1,000 Vac 20 mA for 1 min (between charging and FG terminals)	500 Vdc, 10 MΩ or more (between charging and FG terminals)
GP-4301TM			7 ms or less				
GP-4000M			7 ms or less				

\*1 You must use DC input with a Class 2 power supply.

\*2 Display Module: 1.6 W or less / Rear Module: 5.2 W or less.

#### Environmental Specifications

		GP-4201TM	GP-4301TM
Physical Environment	Surrounding Air Temperature	0...50 °C (32...122 °F)	0...50 °C (32...122 °F)
	Storage Temperature	-20...60 °C (-4...140 °F)	-20...60 °C (-4...140 °F)
	Surrounding Air and Storage Humidity	85% RH (Wet bulb temperature: 39 °C (102.2 °F) or less - no condensation.)	85% RH (Wet bulb temperature: 39 °C (102.2 °F) or less - no condensation.)
	Dust	0.1 mg/m <sup>3</sup> (10 <sup>-7</sup> oz/ft <sup>3</sup> ) or less (non-conductive levels)	0.1 mg/m <sup>3</sup> (10 <sup>-7</sup> oz/ft <sup>3</sup> ) or less (non-conductive levels)
	Pollution Degree	For use in Pollution Degree 2 environment	For use in Pollution Degree 2 environment
	Corrosive Gases	Free of corrosive gases	Free of corrosive gases
	Atmospheric Pressure (Operating Altitude)	800...1,114 hPa (2,000 m (6,561 ft) or lower)	800...1,114 hPa (2,000 m (6,561 ft) or lower)
Mechanical Environment	Vibration Resistance	EN 61131-2 compliant 5...9 Hz Single amplitude: 3.5 mm (0.14 in)	EN 61131-2 compliant 5...9 Hz Single amplitude: 3.5 mm (0.14 in)
	Shock Resistance	IEC/EN 61131-2 compliant 147 m/s <sup>2</sup> , X, Y, Z 3directions	IEC/EN 61131-2 compliant 147 m/s <sup>2</sup> , X, Y, Z 3directions
Electrical Environment	Electrical fast transient/burst	IEC 61000-4-4 2 kV Power port 1 kV Signal ports	IEC 61000-4-4 2 kV Power port 1 kV Signal ports
	Electrostatic Discharge Immunity	IEC 61000-4-2 6 kV Contact discharge 8 kV Air discharge	IEC 61000-4-2 6 kV Contact discharge 8 kV Air discharge

**Structural Specifications**

	<b>GP-4201TM</b>	<b>GP-4301TM</b>	<b>GP-4000M</b>
Structure	NEMA#250 TYPE 4X (indoor, installed in an enclosure) Front panel: IP 65f Rear panel: IP 20	NEMA#250 TYPE 4X (indoor, installed in an enclosure) Front panel: IP 65f Rear panel: IP 20	IP 20
Cooling Method	Natural air circulation	Natural air circulation	Natural air circulation
Weight	0.36 kg (0.79 lb.) or less	0.62 kg (1.36 lb) or less	0.21 kg (0.46 lb) or less
Grounding	Functional grounding: Grounding resistance of 100 $\Omega$ , 2 mm <sup>2</sup> (AWG 14) or thicker wire, or your country's applicable standard.		

**⚠ CAUTION**

**EQUIPMENT DAMAGE**

Do not expose the device in direct sunlight.

**Failure to follow these instructions can result in injury or equipment damage.**

---

## 3.2 Functional Specifications

---

### Overview

This section presents the unities functional specifications of the display, memory and interfaces.

### What's in this Section?

This section contains the following topics:

Topic	Page
Display	31
Memory, Clock, and Touch Panel	32

## Display

### Display Specifications

	<b>GP-4201TM</b>	<b>GP-4301TM</b>
Display Type	TFT Color LCD	TFT Color LCD
Display Size	3.5"	5.7"
Resolution	320 x 240 pixels (QVGA)	320 x 240 pixels (QVGA)
Effective Display Area	W70.56 x H52.92 mm (W2.78 x H2.08 in)	W115.2 x H86.4 mm (W4.53 x H3.40 in)
Display Colors	65,536 colors	65,536 colors
Backlight	White LED (User nonreplaceable parts.)	White LED (User nonreplaceable parts.)
Backlight Service Life	50,000 hrs. or more (continuous operation at 25 °C (77 °F) before backlight brightness decreases to 50%)	50,000 hrs. or more (continuous operation at 25 °C (77 °F) before backlight brightness decreases to 50%)
Brightness Control	16 Levels (Adjusted with the touch panel or the software)	16 Levels (Adjusted with the touch panel or the software)
Language Fonts*1	Japanese, ASCII, Chinese (Simplified), Chinese (Traditional), Korean, Cyrillic, Thai	Japanese, ASCII, Chinese (Simplified), Chinese (Traditional), Korean, Cyrillic, Thai
Character Sizes	Standard font: 8 x 8, 8 x 16, 16 x 16 and 32 x 32 pixel fonts Stroke font: 6...127 pixel fonts Image font: 8...72 pixel fonts	Standard font: 8 x 8, 8 x 16, 16 x 16 and 32 x 32 pixel fonts Stroke font: 6...127 pixel fonts Image font: 8...72 pixel fonts
Font Sizes	Standard font: Width can be expanded up to 8 times. Height can be expanded up to 8 times.	Standard font: Width can be expanded up to 8 times. Height can be expanded up to 8 times.
Text	8 x 8 pixels	40 characters x 30 rows
	8 x 16 pixels	40 characters x 15 rows
	16 x 16 pixels	20 characters x 15 rows
	32 x 32 pixels	10 characters x 7 rows

\*1. Please refer to the GP-Pro EX Reference Manual for details on font types and character codes.

## Memory, Clock, and Touch Panel

### Memory

		GP-Pro EX Ver.3.01 or earlier	GP-Pro EX Ver.3.1 or later
Application Memory	Screen Area <sup>*1</sup>	FLASH EPROM 8 MB	FLASH EPROM 8 MB (including a logic program area)
	Logic Program Area	None	FLASH EPROM 132 KB <sup>*2</sup> (Equivalent to 15,000 steps)
	Font Area	None	FLASH EPROM 8 MB (when limit exceeded, uses application memory)
Backup Memory	Data Backup	FLASH EPROM 128 KB <sup>*3</sup>	NVSRAM 128 KB
	Variable Area	None	None

\*1. Capacity available for user application (internal memory).

\*2. Up to 60,000 steps can be converted in software. However, this reduces application memory capacity (for screen data) by 1 MB.

\*3. Stores the Alarm History Data, Recipe Data, and Brightness/Contrast Control Settings.

**NOTE:** For details on the memory, refer to the following URL.

<https://www.pro-face.com/trans/en/manual/1082.html>

### Clock

Uses the clock of an external device.

Set up the "Clock Updates" feature with the Editor software. Please refer to the GP-Pro EX Reference Manual "Common" - "Clock Update Settings" for details.

### Touch Panel

Touch Panel Type	Resistive Film (analog)
Touch Panel Service Life	1 million times or more

The touch panel does not support multi-touch (two point touch / multiple point touch). If you touch multiple points on the touch panel, it will operate as if you touched the center-point of the multiple touches.

For example, if you touch two or more points on the touch panel and at the center of the touches is a switch for a drive system, even though you did not directly touch that switch, it may function as if you did.

## WARNING

### UNINTENDED OPERATION

Do not touch two or more points on the touch panel.

**Failure to follow these instructions can result in death, serious injury, or equipment damage.**



## 3.3 Interface Specifications

---

### Overview

This section presents the interface specifications of the GP unit.

### What's in this Section?

This section contains the following topics:

Topic	Page
Interface Specifications	34
Specifications of Serial Interface COM1	35

## Interface Specifications

### Serial Interface COM1

Asynchronous Transmission	RS-232C / RS-422 / RS-485
Data Length	7 or 8 bits
Stop Bit	1 or 2 bits
Parity	None, odd or even
Data Transmission Speed	2,400...115,200 kbps, 187,500 bps
Connector	D-Sub 9 pin (plug)

### USB Interface

	Connector	Power Supply Voltage	Maximum Current Supplied	Maximum Transmission Distance
USB (Type A) Interface	USB2.0 (Type A) x 1	5 Vdc $\pm$ 5%	200 mA	3 m (9.84 ft)
USB (mini-B) Interface	USB2.0 (mini-B) x 1	-	-	5 m (16.40 ft)

### Ethernet Interface

Ethernet (LAN)	IEEE802.3i/ IEEE802.3u, 10BASE-T/100BASE-TX
Connector	Modular jack (RJ-45) x 1

**NOTE:** Ethernet networks must be installed by a trained and qualified person.

When connecting the external device directly to the GP unit with an Ethernet cable, depending on the external device, communication may not be possible. Please connect over a network hub.

The following table describes the LED colors and status:

LED		Contents
Green	lit	Data transmission is available.
	blinking	Data transmission is occurring.

## Specifications of Serial Interface COM1

### Introduction

**NOTE:** For instructions on how to connect to other devices, always refer to the “GP-Pro EX Device/PLC Connection Manual”.

The serial port is not isolated. The SG (signal ground) and the FG (frame ground) terminals are connected inside the unit.

### **DANGER**

#### **ELECTRIC SHOCK**

When using the SG terminal to connect an external device to the unit:

- Verify that a short-circuit loop is not created when you set up the system.
- Connect the #5 SG terminal to remote equipment when the host (PLC) unit is not isolated. Connect the #5 SG terminal to a known reliable ground connection to reduce the risk of damaging the circuit.

**Failure to follow these instructions will result in death or serious injury.**

## Serial Interface COM1

**⚠ CAUTION****LOSS OF COMMUNICATION**

- All connections to the communication ports must not put excessive stress on the ports.
- Securely attach communication cables to the panel or cabinet.

**Failure to follow these instructions can result in injury or equipment damage.**

GP-4201TM/4301TM: D-Sub 9 pin plug connector via an RS-232C/RS-422/RS-485 cable.

Interfit bracket is #4-40 (UNC).

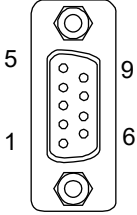
Pin Arrangement	Pin No.	RS-232C		
		Signal Name	Direction	Meaning
 <p>(GP unit side)</p>	1	CD	Input	Carrier Detect
	2	RD(RXD)	Input	Receive Data
	3	SD(TXD)	Output	Send Data
	4	ER(DTR)	Output	Data Terminal Ready
	5	SG	-	Signal Ground
	6	DR(DSR)	Input	Data Set Ready
	7	RS(RTS)	Output	Request to Send
	8	CS(CTS)	Input	Send Possible
	9	CI(RI)	Input	Called status display
	Shell	FG	-	Frame Ground (Common with SG)

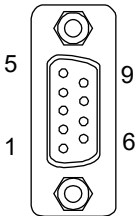
Pin Arrangement	Pin No.	RS-422/RS-485		
		Signal Name	Direction	Meaning
 <p>(GP unit side)</p>	1	RDA	Input	Receive Data A(+)
	2	RDB	Input	Receive Data B(-)
	3	SDA	Output	Send Data A(+)
	4	ERA	Output	Data Terminal Ready A(+)
	5	SG	-	Signal Ground
	6	CSB	Input	Send Possible B(-)
	7	SDB	Output	Send Data B(-)
	8	CSA	Input	Send Possible A(+)
	9	ERB	Output	Data Terminal Ready B(-)
	Shell	FG	-	Frame Ground (Common with SG)

### 3.4 Dimensions

#### Display Module GP-4201TM

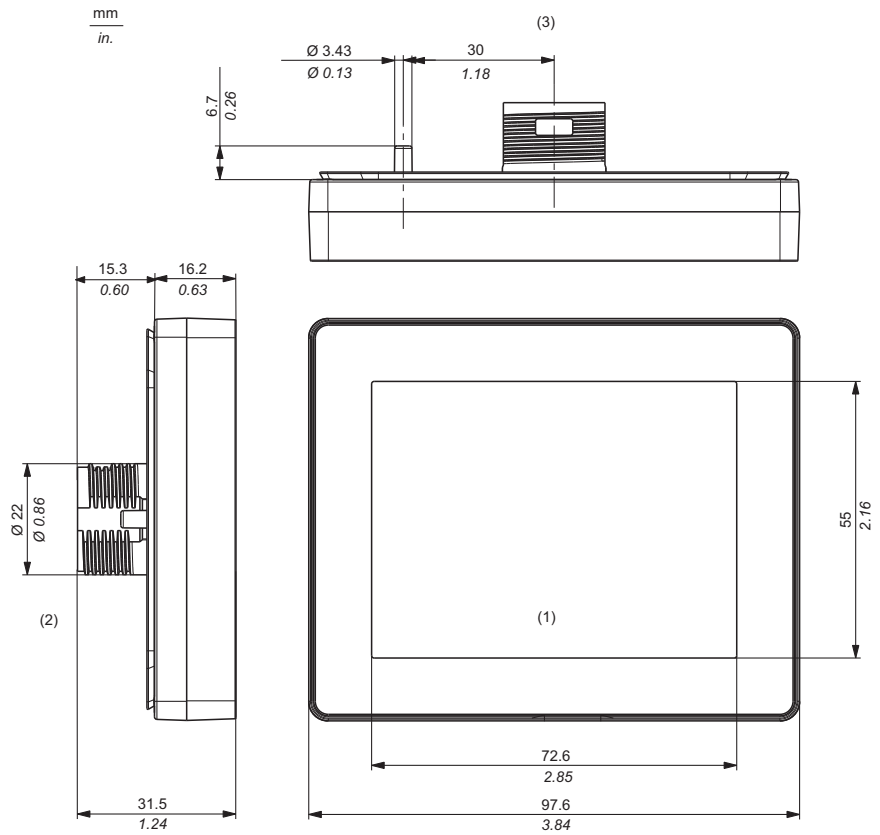

- (1) Front
- (2) Left Side
- (3) Top

# Display Module GP-4301TM

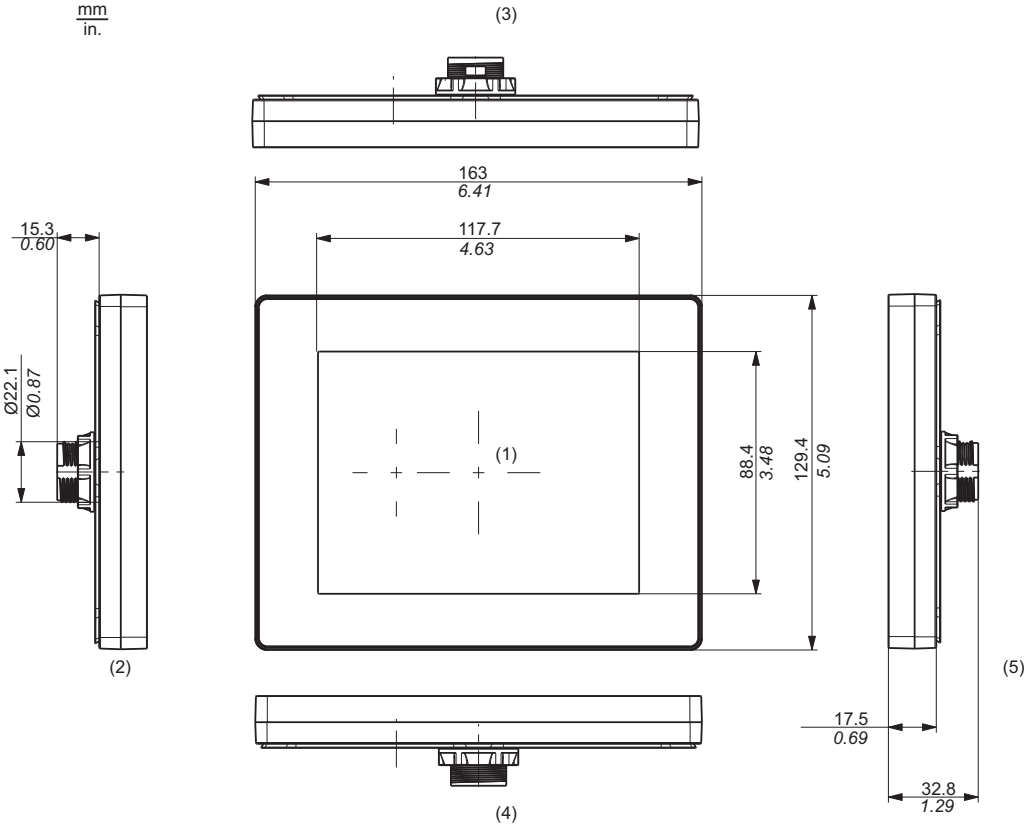

- (1) Front
- (2) Left Side
- (3) Top
- (4) Bottom
- (5) Right Side

### Rear Module (for all GP units)

mm  
in.

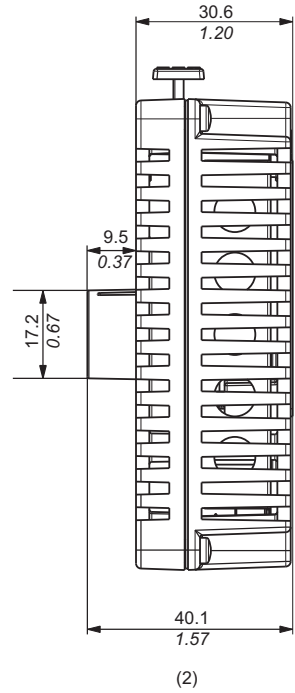
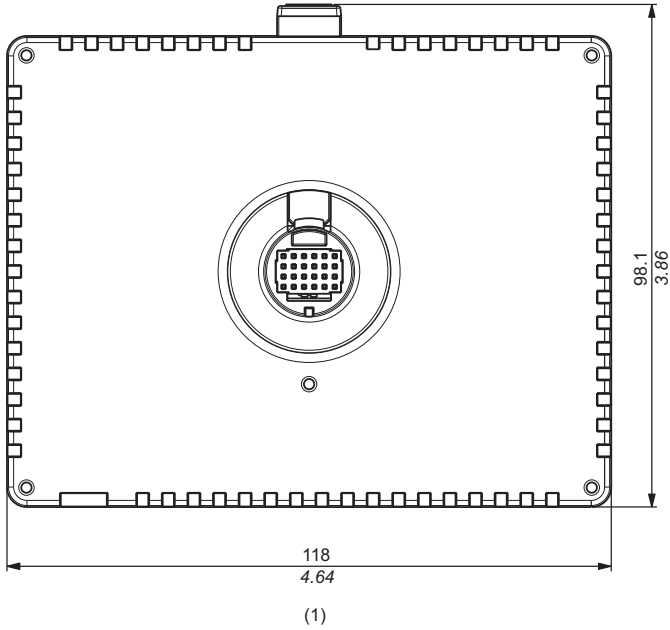

- (1) Front
- (2) Right Side

# Display and Rear Modules GP-4201TM

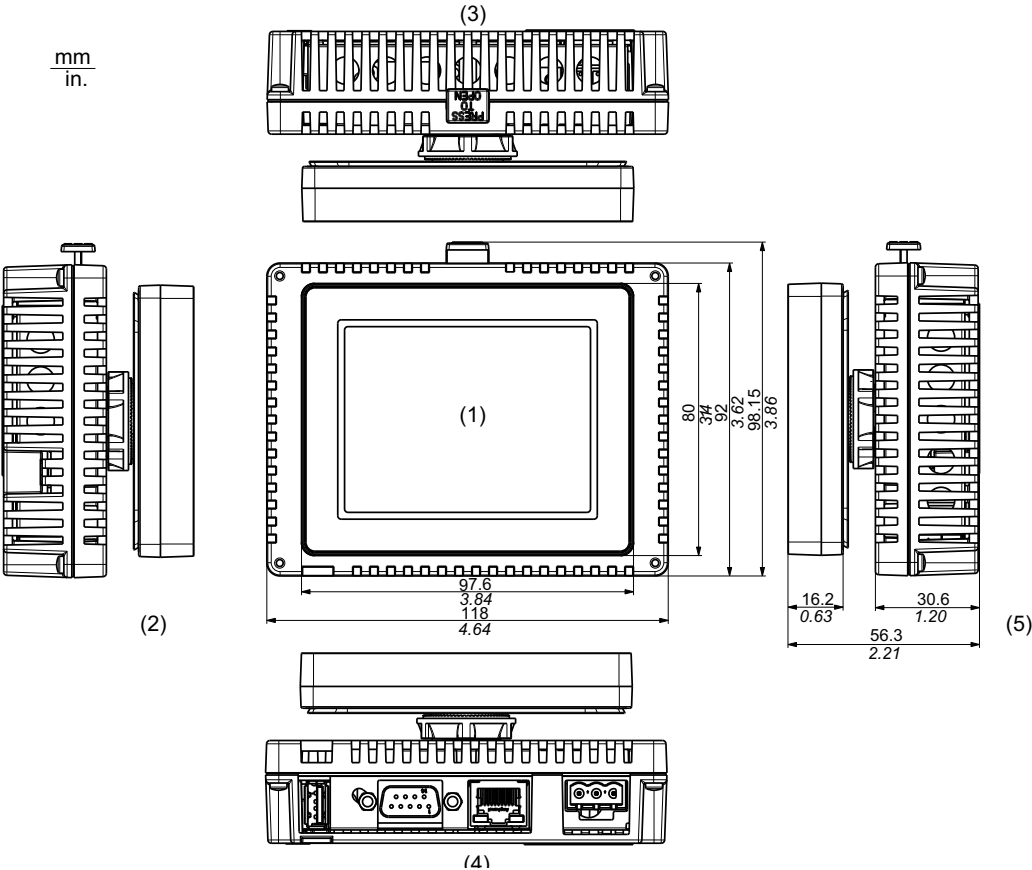

- (1) Front
- (2) Left Side
- (3) Top
- (4) Bottom
- (5) Right Side



## Display and Rear Modules GP-4301TM

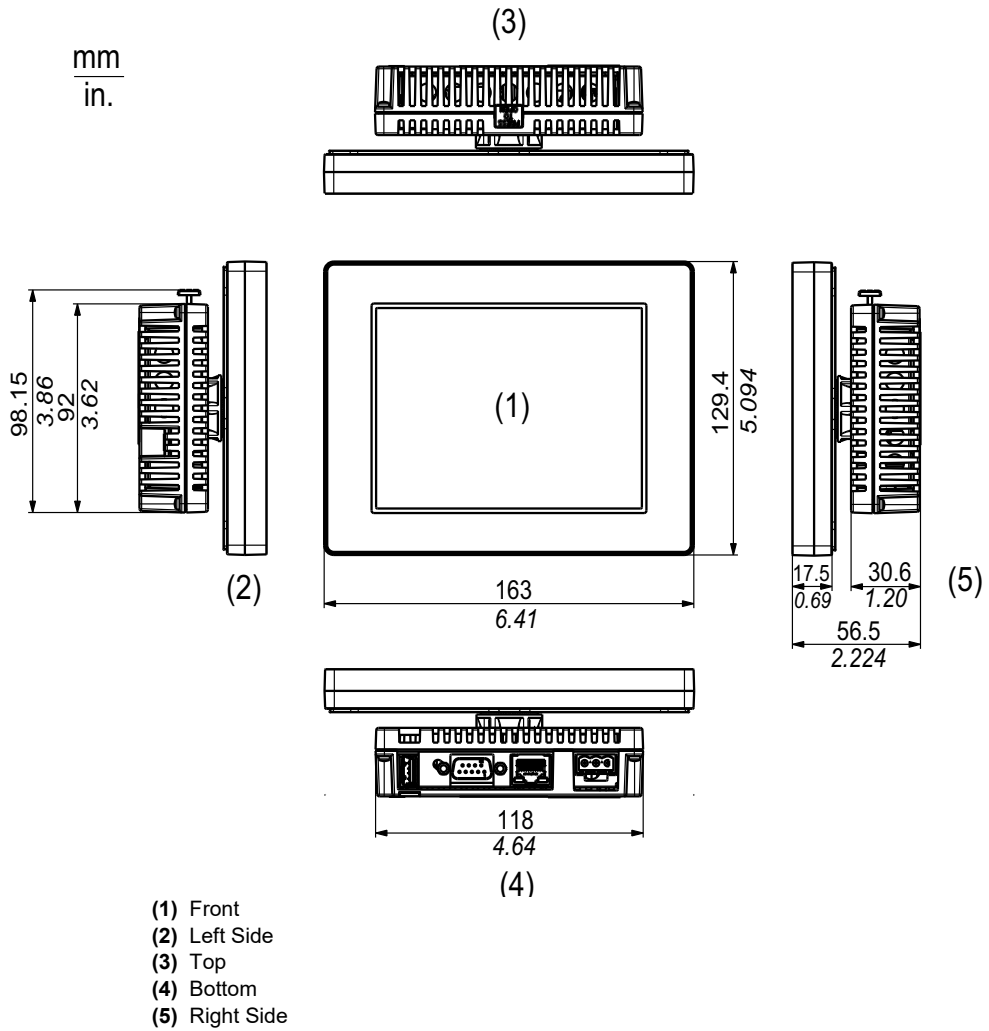

### Cable Attached Dimensions

mm  
in.

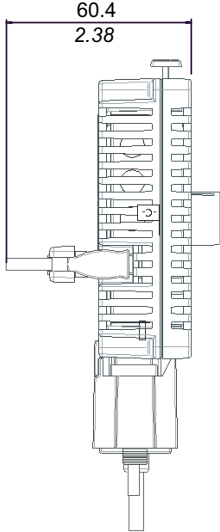

(2)

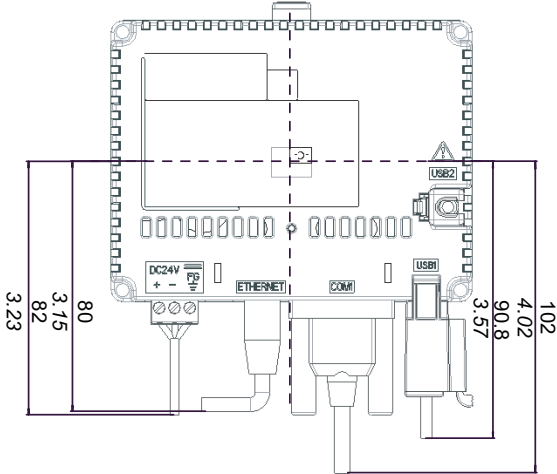

(1)

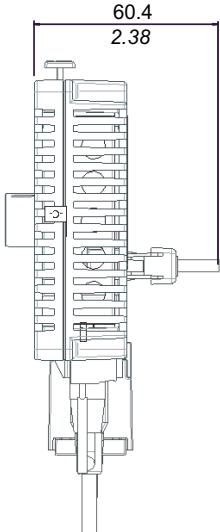

(3)

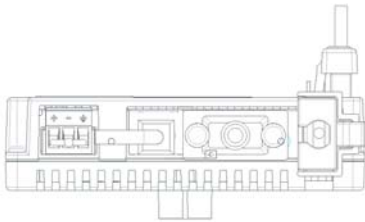

(4)

- (1) Rear
- (2) Left Side
- (3) Right Side
- (4) Bottom

**NOTE:**

All the above values are designed in case of cable bending. The dimensions given here are representative values depending on the type of connection cable used. Therefore, they are all intended for reference only.

## Separation Cable Attached Dimension

$\frac{\text{mm}}{\text{in.}}$

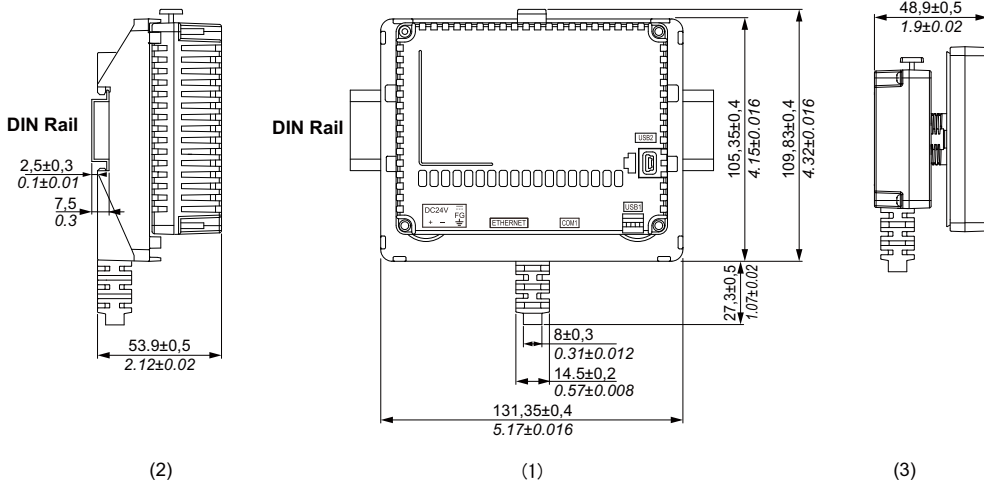

- (1) Rear
- (2) Left Side
- (3) Right Side

**NOTE:**

Use this display module/rear module separation cable when the rear module is installed on a DIN rail:

- The outer diameter of the cable is 8 mm (0.31 in).
- There are 2 types of cable: 3 m (9.84 ft) and 5 m (16.4 ft).
- To assemble this product, you need 20 mm (0.78 in) more space to bend the cable in the end of the rubber.

## DIN Rail Attached Dimension

$\frac{\text{mm}}{\text{in.}}$

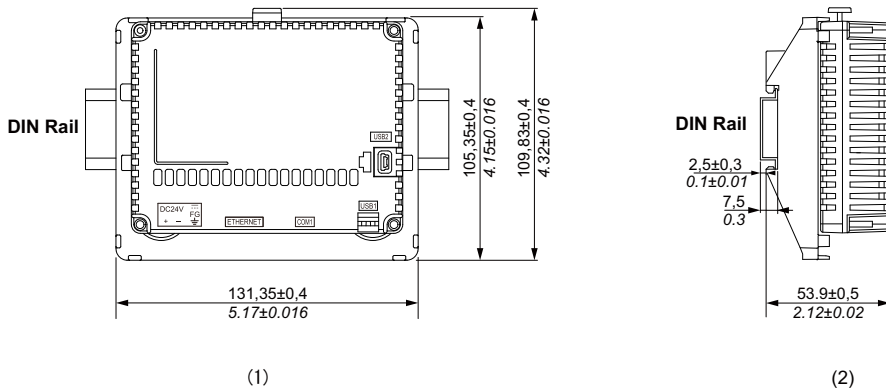

- (1) Rear
- (2) Left Side



# Installation and Wiring

# 4

---

## Overview

This chapter describes the installation procedures and the wiring principles for GP unit.

## What's in this Chapter?

This chapter contains the following sections:

Section	Topic	Page
4.1	Installation	46
4.2	Wiring Principles	57
4.3	USB Interface	64

---

# 4.1 Installation

---

## Overview

This section describes the installation Procedures for GP unit.

## What's in this Section?

This section contains the following topics:

Topic	Page
Panel Cut-out Dimensions and Installation	47
Installation Procedures	51

## Panel Cut-out Dimensions and Installation

### Inserting a GP unit Without an Anti-rotation Tee

Create a panel cut-out and insert the display module of the unit into the panel from the front. The following illustration shows the panel cut-out for a GP unit without a tee:

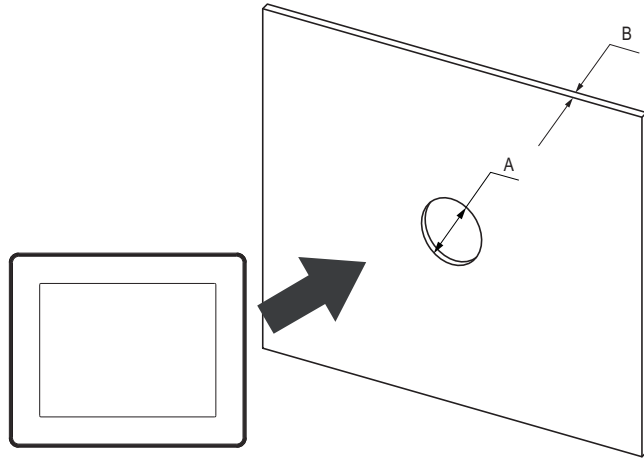

#### Dimensions

Unit	A (mm)	A (in)	B (mm) (1)	B (in) (1)	B (mm) (2)	B (in) (2)
GP-4201TM	+0	+0				
GP-4301TM	22.50	0.88	1.5 to 6	0.06 to 0.23	3 to 6	0.11 to 0.23
	-0.30	-0.01				
<b>The Material of the panel</b>						
(1) Steel sheet						
(2) Glass fiber reinforced plastics (minimum GF30)						

**NOTE:** Without the tee option, the rotating torque that can be supported by the display module is 2.5 N•m (22.12 in-lb).

## Inserting a GP unit With an Anti-rotation Tee

### NOTE:

An Anti-rotation Tee is included in the package. It's appropriate for installing the GP unit horizontally into the panel.

Create a panel cut-out and insert the display module of the unit into the panel from the front. The following illustration shows the panel cut-out for a GP unit using a tee:

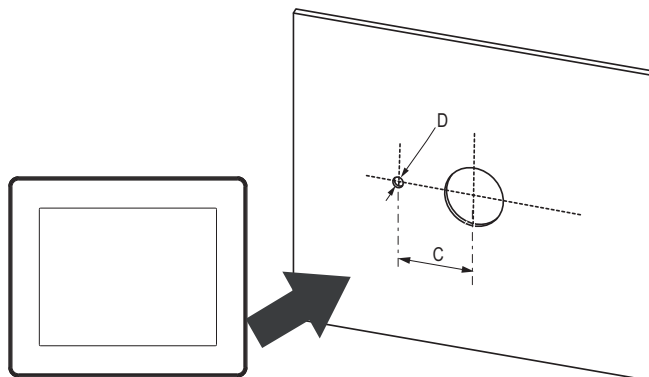

### Dimensions

Unit	C (mm)	C (in)	D (mm)	D (in)
GP-4201TM	+0	+0	+0	+0
GP-4301TM	30.00	1.18	4.00	0.15
	-0.20	-0.007	-0.20	-0.007

**NOTE:** With the tee option, the rotating torque is 6 N•m (53.10 in-lb).



**Illustration**

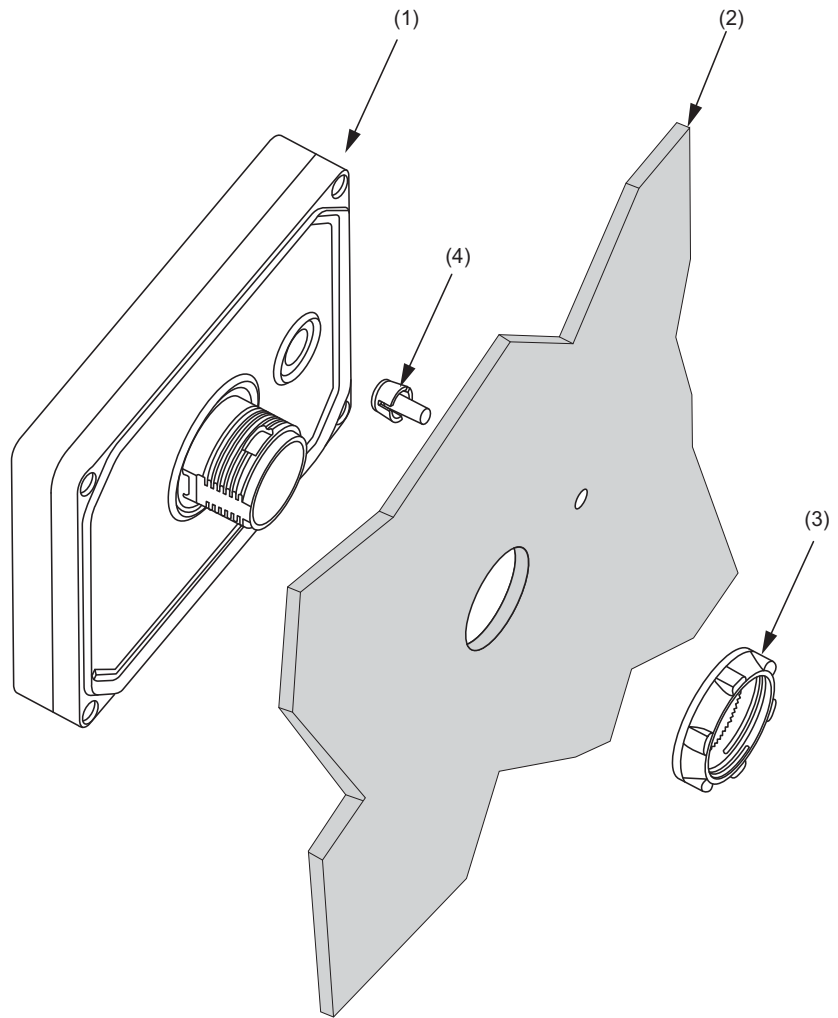

- (1) Display module
- (2) Panel
- (3) Display Installation Nut
- (4) Anti-rotation tee

**2mm-high spacer**

The Spacer, supplied in the *Accessories kit (sold separately)* (see page 26), allows mounting the product on a following panel.

Material	GP-4201TM	GP-4301TM
Steel sheet	1 to 1.5 mm (0.04 and 0.06 in)	1 to 1.5 mm (0.04 and 0.06 in)
Glass fiber reinforced plastics (minimum GF30)	1 to 3 mm (0.04 to 0.12 in)	2 to 3 mm (0.08 to 0.12 in)
Other plastic	1 to 3 mm (0.04 to 0.12 in)	not possible

The following illustration shows the assembly with the panel adaptor:

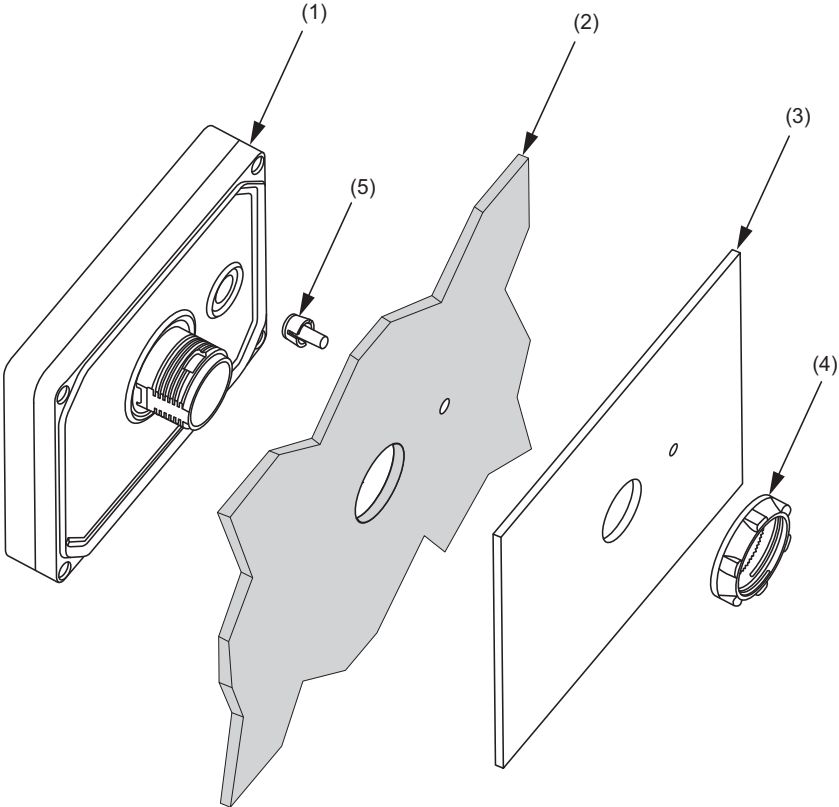

- (1) Display module
- (2) Panel
- (3) Panel adaptor
- (4) Display Installation Nut
- (5) Anti-rotation tee

## Installation Procedures

**NOTE:**

When transporting a panel with a GP installed, remove its rear module. The stress from cables connecting peripheral equipment may cause damage to GP connectors.

Even though the GP may still be under warranty, damage caused by transporting a panel with the GP rear module installed can be repaired for a fee.

### Panel Setup Procedure

Mount the unit in an enclosure that provides a clean, dry, robust and controlled environment (IP65f enclosure or UL508 4x, if indoors.) (see page 28)

Before installing the GPunit verify that:

- The gasket is flat and not damaged.
- The installation panel or cabinet surface is flat (planarity tolerance: 0.5 mm (0.019 in), in good condition and has no jagged edges. Metal reinforcing strips may be attached to the inside of the panel, near the panel cut-out, to increase the rigidity.
- The panel must be designed to avoid any induced vibration resonance on the rear module exceeding a punctual factor of 10 and to avoid any induced permanent vibration resonance.

To reduce the resonance use the spacer supplied in the Accessories kit (sold separately).

- The ambient operating temperature and the ambient humidity are within their specified ranges (see page 28).
- The heat from surrounding equipment does not cause the unit to exceed its specified operating temperature (see page 28).
- The panel face is not inclined more than 30° when installing the unit in a slanted panel:

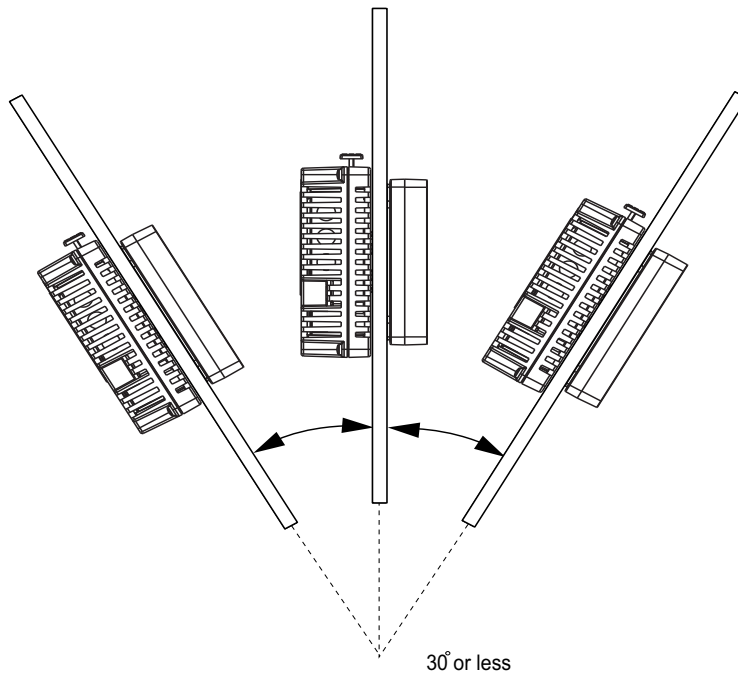

- When mounting the GP unit vertically, ensure that the right side of the unit faces up (i.e. the yellow button should be at the left).

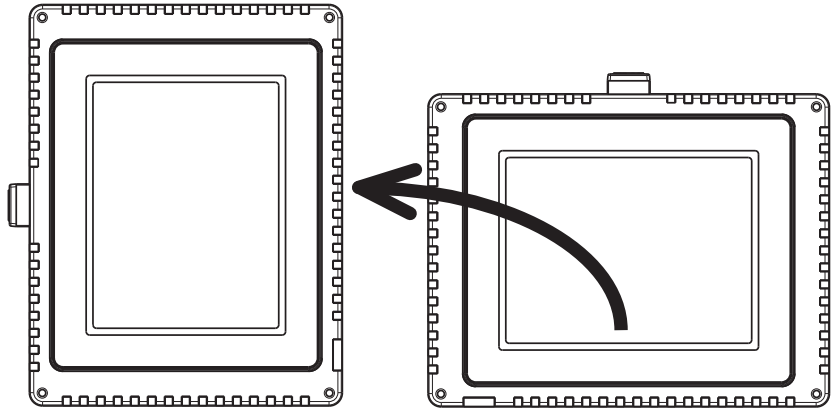

- The unit is at least 100 mm (3.94 in) away from adjacent structures and other equipment for easier maintenance, operation and improved ventilation:

$\frac{\text{mm}}{\text{in.}}$

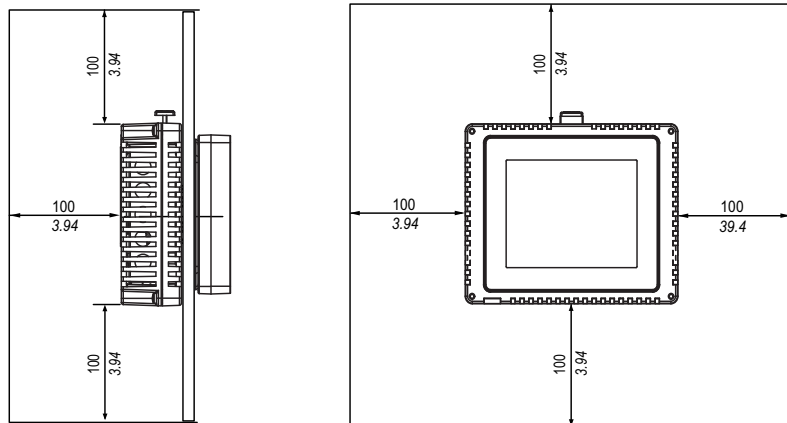

### Pressure Differences

When applying and installing this product, it is important that steps are taken to eliminate any pressure difference between the inside and the outside of the enclosure in which this product is mounted. Higher pressure inside the enclosure can cause delamination of the front membrane of the display. Even a small pressure difference inside the enclosure will act on the large area of the membrane and can result in sufficient force to delaminate the membrane and thus cause failure of the touch capability. Pressure differences can often occur in applications where there are multiple fans and ventilators moving air at different rates in different rooms. Please follow these techniques to ensure that this product's function is not impacted by this mis-application:

1. Seal all conduit connections inside of the enclosure, especially those that lead to other rooms that may be at a different pressure.
2. Where applicable, install a small weep hole at the bottom of the enclosure to allow equalization of the internal and external pressure.

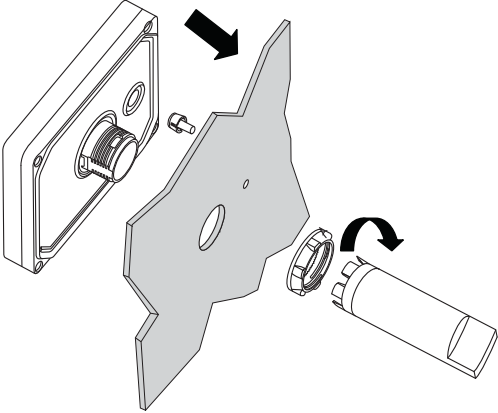
Step	Action
1	Place the unit on a clean and level surface with the display panel facing downward.
2	<p>The support thickness depends on the material:</p> <ul style="list-style-type: none"> <li>● Steel: 1.5 to 6 mm (0.06 to 0.23 in)</li> <li>● Glass fiber reinforced plastics (minimum GF30): 3 to 6 mm (0.11 to 0.23 in)</li> </ul> <p>If the panel thickness is less than the above values, use the spacer in Accessories kit (sold separately). For the panel thickness and materials when using the spacer, please refer to "2 mm-high spacer" (see page 50).</p>
3	<p>Create the correct sized holes required to install the unit, using the Panel Cut-out Dimension and Installation (see page 47).</p> <p><b>NOTE:</b> The field wiring opening for controller when mounted onto an enclosure shall have an area of not more than 775 mm<sup>2</sup> (1.2 in<sup>2</sup>).</p>
4	<p>Insert the display module (with Tee, if used) into the panel hole:</p>  <p>Screw the nut with the socket wrench with a torque between 1.2 and 2 N•m (10.62 and 17.70 in-lb).</p>

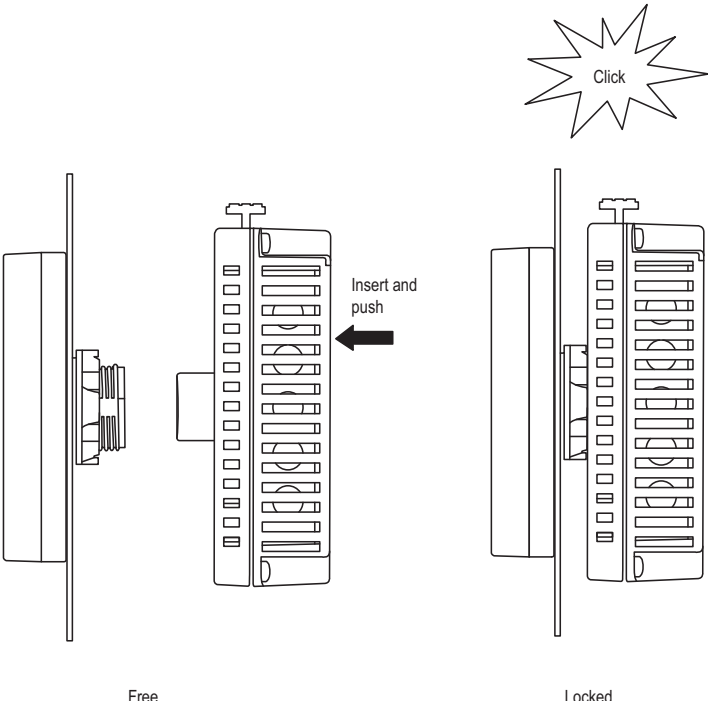
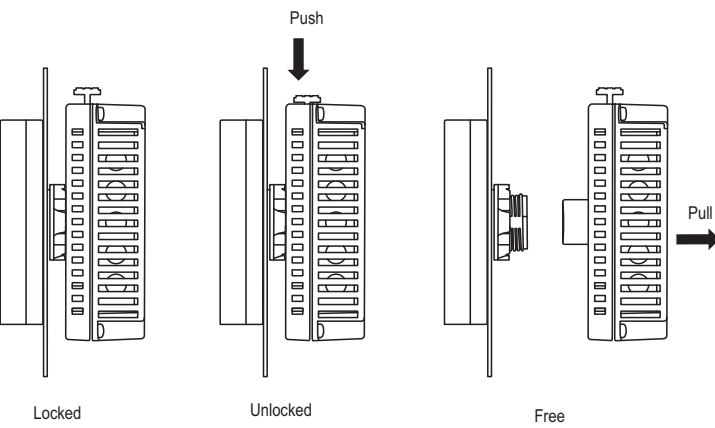
Step	Action
5	<p>Insert and push the rear module until it locks into place:  <b>NOTE:</b> Install the display module and the rear module in the orientation shown in the illustration. If either unit is installed incorrectly, the connector may be damaged.</p>  <p style="text-align: center;">Free <span style="margin-left: 200px;">Locked</span></p>
6	<p>To remove the rear module, push the yellow button to unlock it, then pull the rear module out:</p>  <p style="text-align: center;">Locked <span style="margin-left: 100px;">Unlocked</span> <span style="margin-left: 100px;">Free</span></p>

## **NOTICE**

### **EQUIPMENT DAMAGE**

Be sure to remove the rear module from the display module without twisting.

**Failure to follow these instructions can result in equipment damage.**

### Installing and Removing the Rear Module on a DIN Rail

This section describes how to install and remove the rear module on a DIN rail.

**NOTE:**

Attach front module and rear module both when you use a display module/rear module separation cable.

#### Installing the Rear Module on a DIN Rail

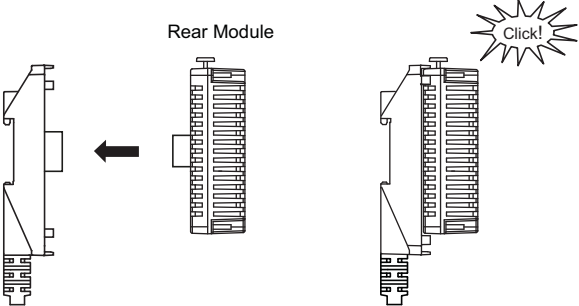
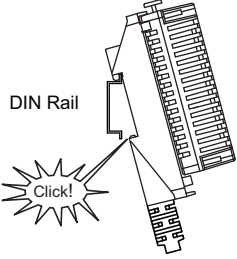
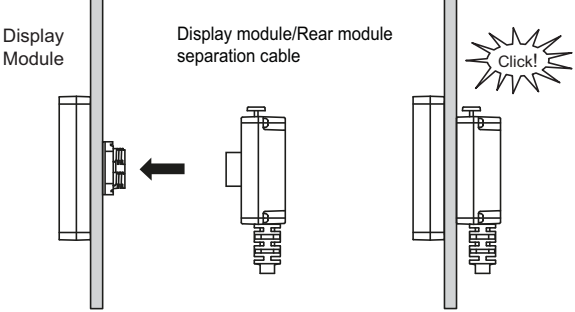
Step	Action
1	Using screws, to fasten the DIN rail to a panel surfaces.
2	<p>Affix the display module/rear module separation cable or the rear module installation adapter to the rear module.</p> 
3	<p>Position the top groove of the rear module on the top edge of the DIN rail and press the assembly against the DIN rail until you hear the DIN rail clip click into place.</p> 
4	<p>Install the display on the cabinet and affix the display module/rear module separation cable to the display.</p> 

**Removing the Rear Module from a DIN Rail**

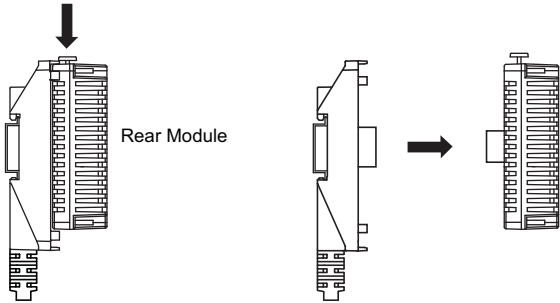
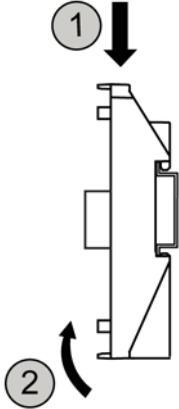
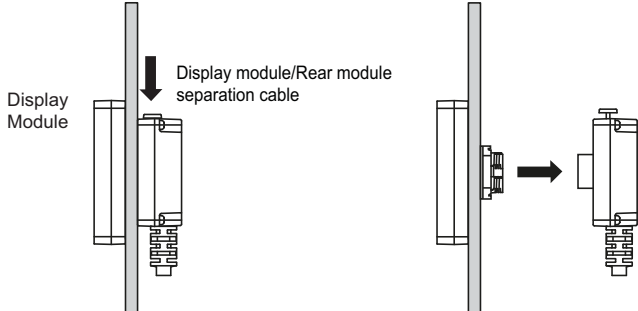
Step	Action
1	<p data-bbox="467 237 1237 285">To remove the rear module, push the yellow button to unlock it, then pull the rear module out.</p> 
2	
3	<p data-bbox="467 1136 1190 1193">Remove the display module/rear module separation cable and display module from a panel..</p> 



## 4.2 Wiring Principles

---

### Overview

This section presents GP unit wiring principles.

### What's in this Section?

This section contains the following topics:

Topic	Page
Connecting the Power Cord	58
Connecting the Power Supply	60
Grounding	62

## Connecting the Power Cord

### **⚠ WARNING**

#### **HAZARD OF ELECTRIC SHOCK**

- When the frame ground (FG) terminal is connected, verify the wire is grounded. Not grounding the unit can result in excessive Electromagnetic Interference (EMI). Grounding is required to meet EMC level immunity.
- Remove power before wiring to the power terminals of the unit.
- The unit uses only 24 Vdc power. Using any other level of power can damage both the power supply and the unit.
- Since there is no power switch on the GP unit, be sure to attach a breaker-type switch to its power cord.

**Failure to follow these instructions can result in death, serious injury, or equipment damage.**

#### **NOTE:**

The shield ground (SG) and FG terminals are connected internally in the unit.

### Power Cord Preparation

Before using your power cord:

- Verify the ground wire is the same gauge or heavier than the power wires.
- Do not use aluminum wires for the power cord for power supply.
- If the conductor end (individual) wires are not twisted correctly, the end wires may either short loop to each other or against an electrode. To avoid this, use D25CE/AZ5CE cable ends.
- Use wires that are 0.75 to 2.5 mm<sup>2</sup> (AWG 18 -12) for the power cord, and twist the wire ends before attaching the terminals.
- The conductor type is solid or stranded wire.
- To reduce electromagnetic noise, make the power cord as short as possible.

### DC Power Supply Connector Illustration

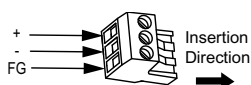

Connection	Wire
+	24 V
-	0 V
FG	Grounded terminal connected to the unit chassis

### How to connect the Power Cord

The following table explains how to connect the DC power supply connector:

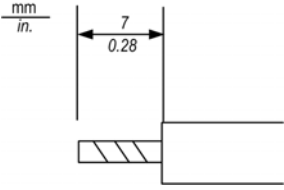
Step	Action
1	Remove the power cord from the power supply.
2	Remove the DC power supply connector from the unit.
3	Remove 7 mm (0.28 in) of the vinyl cover of each of the power cord wires. 
4	If using stranded wire, twist the ends. Tinning the ends with solder reduces the risk of fraying and enhances electrical transfer.
5	Connect the wires to the DC power supply connector by using a flat-blade screwdriver (Size 0.6 x 3.5).
6	Torque the mounting screws: 0.5 to 0.6 N•m (4.4 to 5.2 lb-in).
7	Replace the DC power supply connector to the power connector on the side of the unit.

**NOTE:**

- Do not solder the wire directly to the power receptable pin.
- The power supply cord must meet the specification shown above. Twist the power cords together, up to the DC power supply connector, for EMC cancellation. (See illustration as shown below).

### Power Connection

The following illustration displays a connection of the power cord:

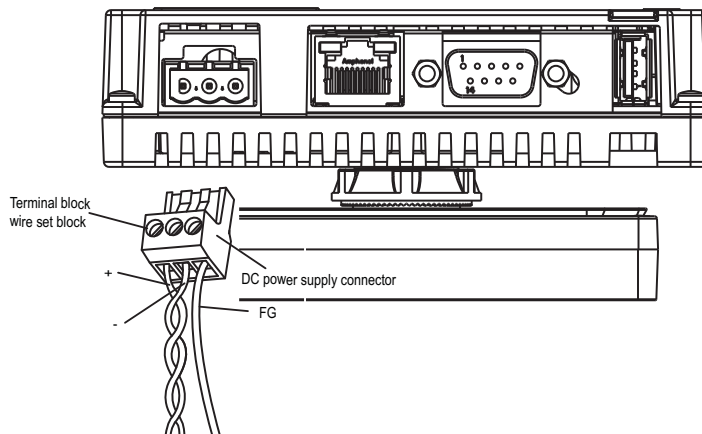

## Connecting the Power Supply

### Precautions

- Connect the power cord to the power connector on the side of the unit using the DC power supply connector.
- Use a regulated power supply with a Class 2 power supply between the line and the ground.
- Do not bundle the power supply cord with, or keep close to, main circuit lines (high voltage, high current), or input/output signal lines.
- Connect a lightning surge absorber to handle power surges.

Excessive stress on the power connection or attempting to install a unit with the power cables connected may disconnect or cause damage to the power connections. This can cause short circuits, fire or unintended equipment operation.

### **WARNING**

#### **SHORT CIRCUITS, FIRE, OR UNINTENDED EQUIPMENT OPERATION**

- Securely attach power cables to the panel or cabinet.
- Use the designated torque to tighten the unit terminal block screws.
- Install and fasten unit on installation panel or cabinet prior to connecting Power Supply and Communication lines.

**Failure to follow these instructions can result in death, serious injury, or equipment damage.**

### Power Supply Connections

For ease of maintenance, use the following optional connection diagram to set up your power supply connections.

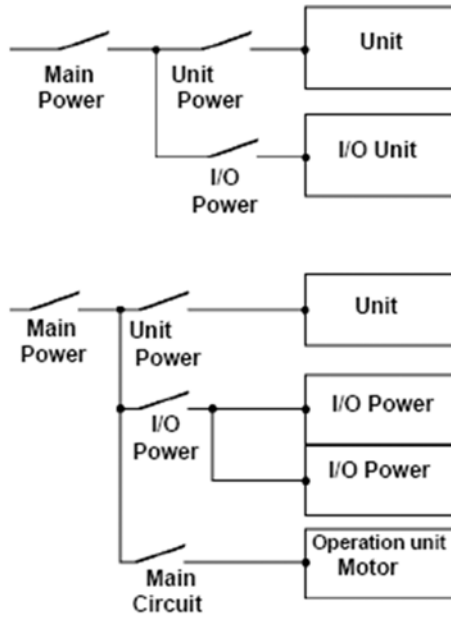

**NOTE:**

- Ground the surge absorber (E1) separately from the unit (E2).
- Select a surge absorber that has a maximum circuit voltage greater than the peak voltage of the power supply.

The following diagram displays a lightning surge absorber connection:

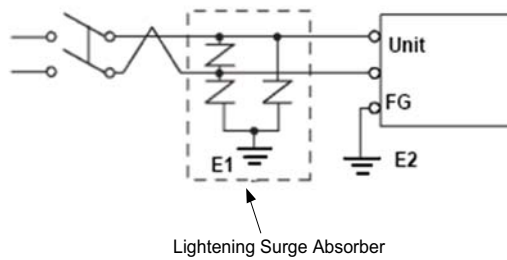

## Grounding

### Introduction

Take the following precautions for grounding the unit.

### Exclusive Grounding

Connect the frame ground (FG) terminal on the power plug to an exclusive ground.

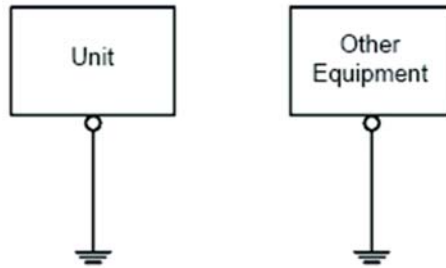

### Grounding Procedure

Step	Action
1	Check that the grounding resistance is less than 100 $\Omega$ .
2	Create the connection point as close to the unit as possible, and make the wire as short as possible. When using a long grounding wire, replace the thin wire with a thicker wire, and place it in a duct.

### Common Grounding

Precautions:

Electromagnetic Interference (EMI) can be created if the devices are improperly grounded. Electromagnetic Interference (EMI) can cause loss of communication.

Do not use common grounding, except for the authorized configuration described below.

If exclusive grounding is not possible, use a common connection point.

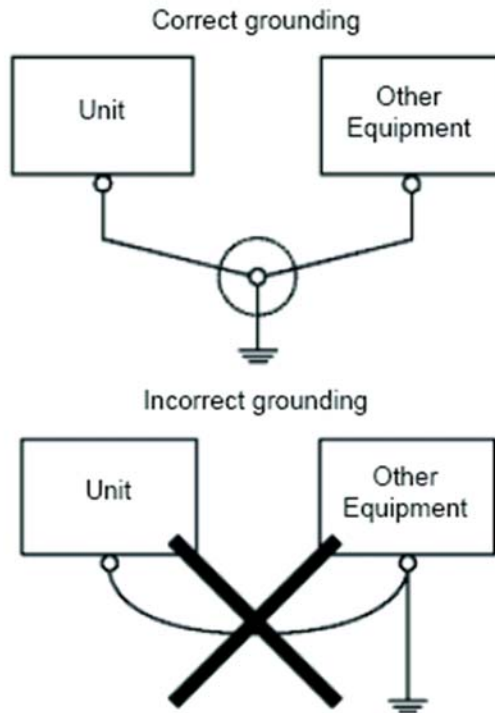

---

## 4.3 USB Interface

---

### Overview

This section presents the USB interface.

### What's in this Section?

This section contains the following topics:

Topic	Page
Important Considerations When Using the USB interface	65
USB Data Transfer Cable (ZC9USCBMB1) - USB Driver Installation	66
USB (Type A) interface	67
USB (mini-B) interface	70



## Important Considerations When Using the USB interface

### Introduction

Data transfer cable (ZC9USCBMB1) can be attached to the USB interface to allow data transfer from the computer to the unit.

### **WARNING**

#### **RISK OF EXPLOSION IN HAZARDOUS LOCATIONS**

In hazardous locations as described in ANSI/ISA - 12.12.01:

- Confirm that the USB cable has been attached with the USB cable clamp before using the USB host interface.
- Remove power before attaching or detaching any connector(s) to or from the unit.

**Failure to follow these instructions can result in death, serious injury, or equipment damage.**

## USB Data Transfer Cable (ZC9USCBMB1) - USB Driver Installation

### Important information

Follow the procedure described below to avoid damage to the cable connector or the unit:

- Do not connect the USB data transfer cable until told to do so in the instructions.
- Insert the connector at the correct angle when connecting the USB data transfer cable to the PC or to the unit.
- Hold the connector, not the cable itself when disconnecting the cable.
- Use the port designated during installation. If the cable is unplugged from the port designated during installation and connected to a different port, the OS (Operating System) will not recognize the new port.
- Restart the PC and quit all resident applications before re-installing the software if the installation does not complete successfully.

**NOTE:** For transfer methods, refer to the following manual: GP-Pro EX Reference Manual "Transferring Project Files via USB Transfer Cable".

## USB (Type A) interface

### Introduction

When using a USB device, you can attach a USB clamp to the USB interface to prevent the USB cable from being disconnected.

### **⚠ WARNING**

#### **RISK OF EXPLOSION IN HAZARDOUS LOCATIONS**

In hazardous locations as described in ANSI/ISA - 12.12.01:

- confirm that the USB cable has been attached with the USB cable clamp before using the USB host interface.
- remove power before attaching or detaching any connector(s) to or from the unit.

**Failure to follow these instructions can result in death, serious injury, or equipment damage.**

### Attaching the USB Clamp

Step	Action
1	<p>Attach the USB holder to the USB Host Interface on the rear module. Hook the upper pick of the USB holder to the attachment hole of the main unit, and insert the lower pick as shown below to fix the USB holder.</p>

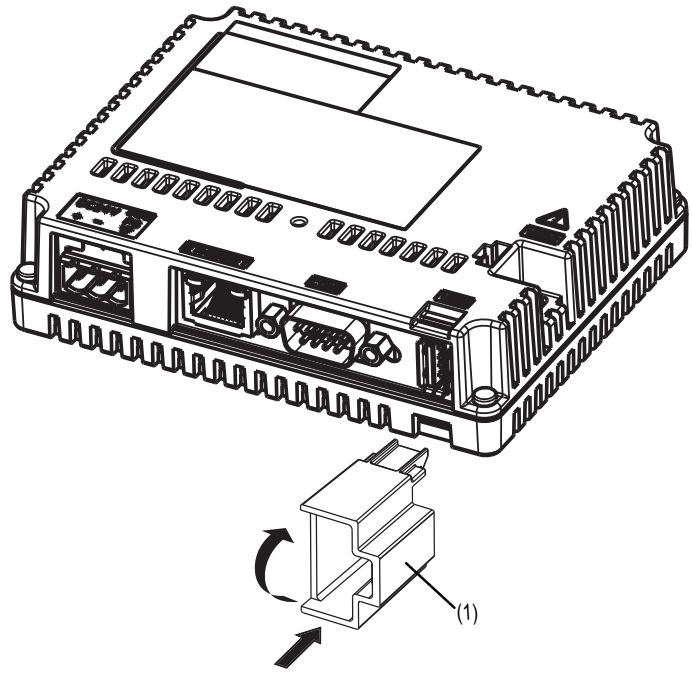

(1) USB Holder

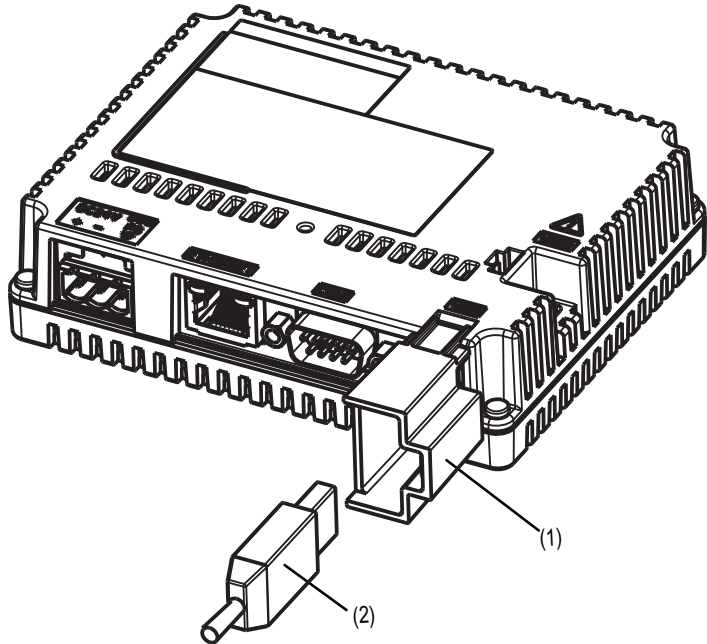
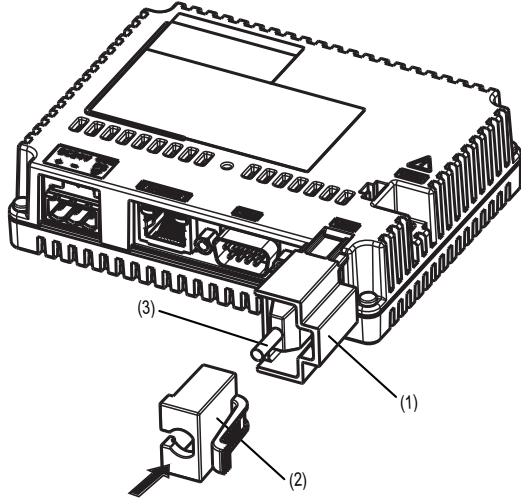
Step	Action
2	<p data-bbox="440 195 912 222">Insert the USB cable into the USB host interface.</p>  <p data-bbox="440 890 600 942">(1) USB Holder (2) USB Cable</p>
3	<p data-bbox="440 948 1238 1000">Attach the USB cover to fix the USB cable in place. Insert the USB cover into the tab of the USB holder.</p>  <p data-bbox="440 1512 600 1590">(1) USB Holder (2) USB Cover (3) USB Cable</p>

### Removing the USB Clamp

Push down the tab of the USB holder and then remove the USB cover.

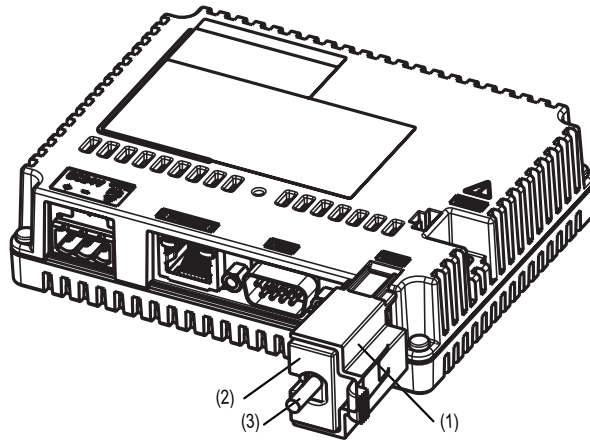

- (1) USB Holder
- (2) USB Cover
- (3) USB Cable

## USB (mini-B) interface

### Introduction

When using a USB device, you can attach a USB holder to the USB interface to prevent the USB cable from being disconnected.

### **WARNING**

#### **RISK OF EXPLOSION IN HAZARDOUS LOCATIONS**

In hazardous locations as described in ANSI/ISA - 12.12.01:

- The USB mini-B connector is for temporary connection only during maintenance and setup of the device. Do not use, connect, or disconnect USB mini-B cable unless area is known to be non-hazardous. Connection or disconnection in an explosive atmosphere could result in an explosion.
- Remove power before attaching or detaching any connector(s) to or from the unit.

**Failure to follow these instructions can result in death, serious injury, or equipment damage.**

## Attaching the USB Clamp

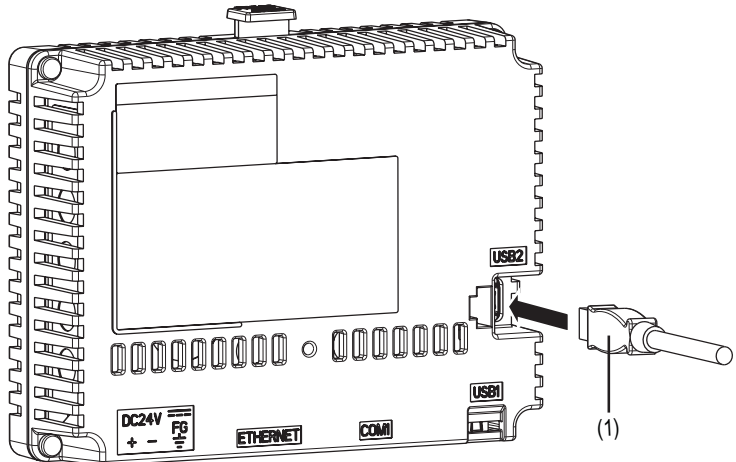
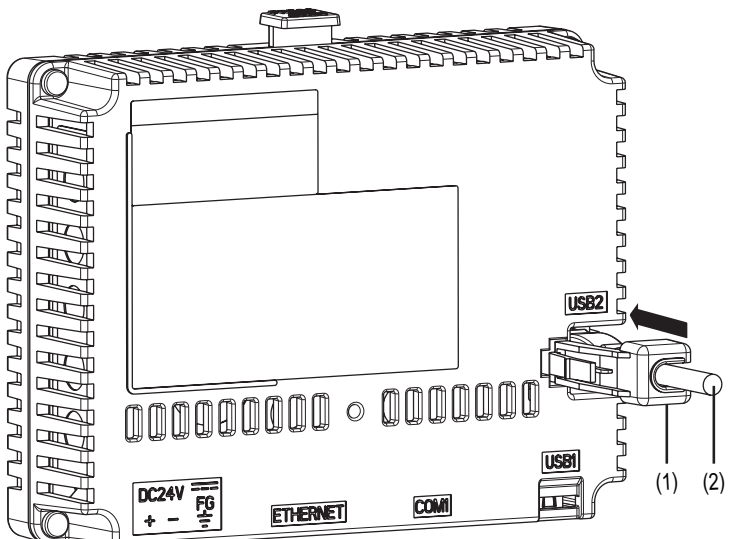
Step	Action
1	<p data-bbox="426 256 889 278">Insert the USB cable into the USB host interface.</p>  <p data-bbox="426 763 570 784">(1) USB Cable</p> <p>The diagram shows a side view of a device with a USB2 port on the right side. A USB cable is being inserted into the port. The cable is labeled (1). The device has several other ports labeled: DC24V, FG, ETHERNET, COM1, and USB1. The USB2 port is located above the COM1 port.</p>
2	<p data-bbox="426 797 916 819">Attach the USB holder to fix the USB cable in place.</p>  <p data-bbox="426 1381 577 1431">(1) USB Holder (2) USB Cable</p> <p>The diagram shows the same device as in step 1, but now a USB holder is attached to the USB2 port. The holder is labeled (1) and the USB cable is labeled (2). The holder is a small rectangular component that fits over the USB2 port and the cable. The device has several other ports labeled: DC24V, FG, ETHERNET, COM1, and USB1. The USB2 port is located above the COM1 port.</p>

**Removing the USB Clamp**

Push down the tab of the USB holder and then remove the USB holder.

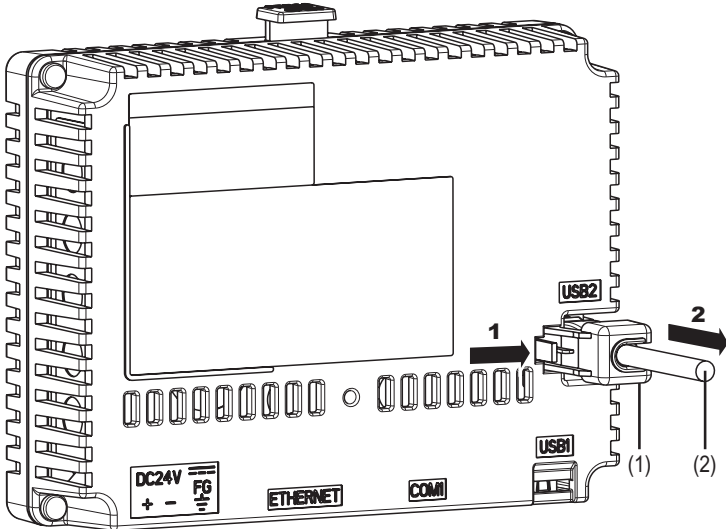

- (1) USB Holder
- (2) USB Cable



# Maintenance



---

## Overview

This chapter explains how to maintain your GP unit.

## What's in this Chapter?

This chapter contains the following topics:

Topic	Page
Regular Cleaning	74
Periodic Check Points	74
After-sales service	74

## Regular Cleaning

### Cleaning the display

#### **NOTICE**

##### **EQUIPMENT DAMAGE**

- Power off the unit before cleaning it.
- Do not use hard or pointed objects to operate the touch panel.
- Do not use paint thinner, organic solvents, or a strong acid compound to clean the unit.

**Failure to follow these instructions can result in equipment damage.**

When the surface or the frame of the display gets dirty, soak a soft cloth in water with a neutral detergent, wring the cloth tightly and wipe the display.

## Periodic Check Points

### Operation Environment

Refer to the Environmental Specifications (*see page 28*).

### Electrical Specifications

The input voltage must be within 20.4 to 28.8 Vdc.

### Related Items

- Are all power cords and cables connected properly? Are there any loose cables?
- Display Installation Nut holding the unit securely?
- Are there scratches or traces of dirt on the installation gasket?

**NOTE:** A gasket with scratches or dirt could have lost much of its water resistance. Be sure to change the gasket for water resistance equivalent to IP65f when scratches or dirt become visible.

## After-sales service

For details on after-sales service, refer to our website at <http://www.pro-face.com/trans/en/manual/1001.html>.