

GP-4402WW/GP-4502WW

Hardware Manual



The information provided in this documentation contains general descriptions and/or technical characteristics of the performance of the products contained herein. This documentation is not intended as a substitute for and is not to be used for determining suitability or reliability of these products for specific user applications. It is the duty of any such user or integrator to perform the appropriate and complete risk analysis, evaluation and testing of the products with respect to the relevant specific application or use thereof. Neither Pro-face nor any of its affiliates or subsidiaries shall be responsible or liable for misuse of the information that is contained herein. If you have any suggestions for improvements or amendments or have found errors in this publication, please notify us.

No part of this document may be reproduced in any form or by any means, electronic or mechanical, including photocopying, without express written permission of Pro-face.

All pertinent state, regional, and local safety regulations must be observed when installing and using this product. For reasons of safety and to help ensure compliance with documented system data, only the manufacturer should perform repairs to components.

When devices are used for applications with technical safety requirements, the relevant instructions must be followed.

Failure to use Pro-face software or approved software with our hardware products may result in injury, harm, or improper operating results.

Failure to observe this information can result in injury or equipment damage.

Copyright © 2015 Digital Electronics Corporation. All Rights Reserved.

Table of Contents



	Safety Information	5
	About the Book.	7
Chapter 1	GP-4402WW/GP-4502WW Panels	9
	Package Contents	10
	Parts Identification and Functions	11
	Certifications and Standards	13
	GP-4402WW/GP-4502WW	14
Chapter 2	Device Connectivity	17
	System Design	18
	Accessories	19
Chapter 3	Specifications	21
3.1	General Specifications	22
	Specifications	22
3.2	Functional Specifications	25
	Display Specifications	26
	Memory, Clock, and Touch Panel	27
3.3	Interface Specifications	28
	Interface Specifications	29
	Serial Interface Specifications RS-232C	31
	Serial Interface Specifications RS-422/485	32
	Ethernet Port	33
3.4	Dimensions	35
	GP-4402WW Dimensions	36
	GP-4502WW Dimensions	37
	Panel-cut Dimensions	38
	Installation Fasteners	39
Chapter 4	Installation and Wiring	41
4.1	Installation	42
	Installation Procedures	43
	Real Time Clock (RTC)	47
4.2	Wiring Principles	49
	Connecting the Power Cord	50
	Connecting the Power Supply	52
	Grounding	54
4.3	USB Port	55
	USB Type A Installation	55
Chapter 5	Maintenance	57
	Precaution	58
	Periodic Check Points	59
	Regular Cleaning	60
	After-sales Service	61

Safety Information



Important Information

NOTICE

Read these instructions carefully, and look at the equipment to become familiar with the device before trying to install, operate, or maintain it. The following special messages may appear throughout this documentation or on the equipment to warn of potential hazards or to call attention to information that clarifies or simplifies a procedure.



The addition of this symbol to a “Danger” or “Warning” safety label indicates that an electrical hazard exists which will result in personal injury if the instructions are not followed.



This is the safety alert symbol. It is used to alert you to potential personal injury hazards. Obey all safety messages that follow this symbol to avoid possible injury or death.

DANGER

DANGER indicates a hazardous situation which, if not avoided, **will result in death** or serious injury.

WARNING

WARNING indicates a hazardous situation which, if not avoided, **could result in death** or serious injury.

CAUTION

CAUTION indicates a hazardous situation which, if not avoided, **could result** in minor or moderate injury.

NOTICE

NOTICE is used to address practices not related to physical injury.

PLEASE NOTE

Electrical equipment should be installed, operated, serviced, and maintained only by qualified personnel. No responsibility is assumed by Pro-face for any consequences arising out of the use of this material.

A qualified person is one who has skills and knowledge related to the construction and operation of electrical equipment and its installation, and has received safety training to recognize and avoid the hazards involved.

About the Book



At a Glance

Document Scope

This manual describes how to use this product.

Validity Note

This documentation is valid for this product.

The technical characteristics of the device(s) described in this manual also appear online at <http://www.pro-face.com/otasuke/qa/gp4x02ww/>.

The characteristics presented in this manual should be the same as those that appear online. In line with our policy of constant improvement we may revise content over time to improve clarity and accuracy. In the event that you see a difference between the manual and online information, use the online information as your reference.

Registered Trademarks

Microsoft and Windows are registered trademarks of Microsoft Corporation in the United States and/or other countries.

Product names used in this manual may be the registered trademarks owned by the respective proprietors.

Related Documents

You can download the manuals related to this product, such as the software manual, from our website "Otasuke Pro" at <http://www.pro-face.com/otasuke/qa/gp4x02ww/>.

Product Related Information

DANGER

HAZARD OF ELECTRIC SHOCK, EXPLOSION OR ARC FLASH

- Disconnect all power from all equipment including connected devices before removing any covers or doors, or installing or removing any accessories, hardware, cables, or wires except under the specific conditions specified in the appropriate hardware guide for this equipment.
- Always use a properly rated voltage sensing device to confirm that the power is off.
- Unplug the power cable from both the equipment and the power supply.
- Replace and secure all covers, accessories, hardware, cables, and wires and confirm that a proper ground connection exists before applying power to the equipment.
- Use only the specified voltage when operating this equipment and any associated products.

Failure to follow these instructions will result in death or serious injury.

WARNING

LOSS OF CONTROL

- Consider the potential failure modes of control paths in the machine control system design, such as:
 - the possibility of backlight failure,
 - unanticipated link transmission delays or failures,
 - the operator being unable to control the machine,
 - the operator making errors in the control of the machine.
- Provide a means to achieve a safe state during and after a path failure for critical control functions such as emergency stop and overtravel stop.
- Provide separate or redundant control paths for critical control functions.
- Test individually and thoroughly each implementation of the panel for correct operation before service.

Failure to follow these instructions can result in death, serious injury, or equipment damage.

WARNING

UNINTENDED EQUIPMENT OPERATION

- Only use software approved by Pro-face for use with this equipment.
- Update your application program every time you change the physical hardware configuration.

Failure to follow these instructions can result in death, serious injury, or equipment damage.

Chapter 1

GP-4402WW/GP-4502WW Panels

Overview

This chapter describes the series of panels and connectable devices.

What Is in This Chapter?

This chapter contains the following topics:

Topic	Page
Package Contents	10
Parts Identification and Functions	11
Certifications and Standards	13
GP-4402WW/GP-4502WW	14

Package Contents

Overview

Make sure that all applicable items listed here are included in the panel package:

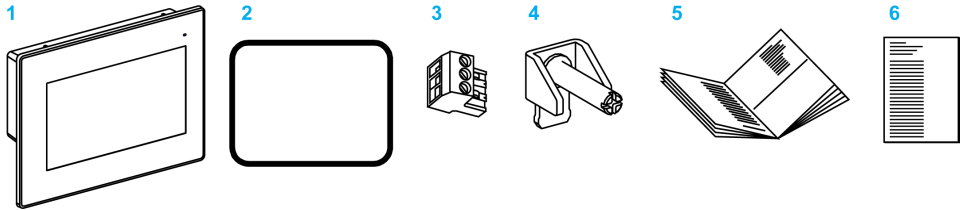

- 1 GP-4402WW (PFXGP4402WADW) or GP-4502WW (PFXGP4502WADW) x 1
- 2 Installation Gasket (attached to the panel)
- 3 DC power connector
- 4 Screw installation fasteners (GP-4402WW x 4, GP-4502WW x 6)
- 5 GP-4402WW/GP-4502WW Installation Guide
- 6 Warning/ Caution Information

Revision

You can identify the product version (PV), revision level (RL), and the software version (SV) from the product label on the panel.

This diagram is a representation of a typical label:

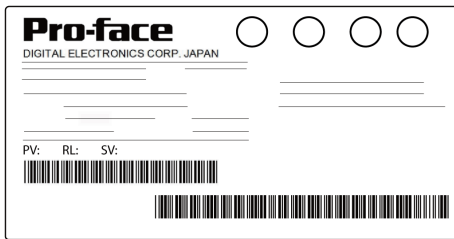

Parts Identification and Functions

Front View

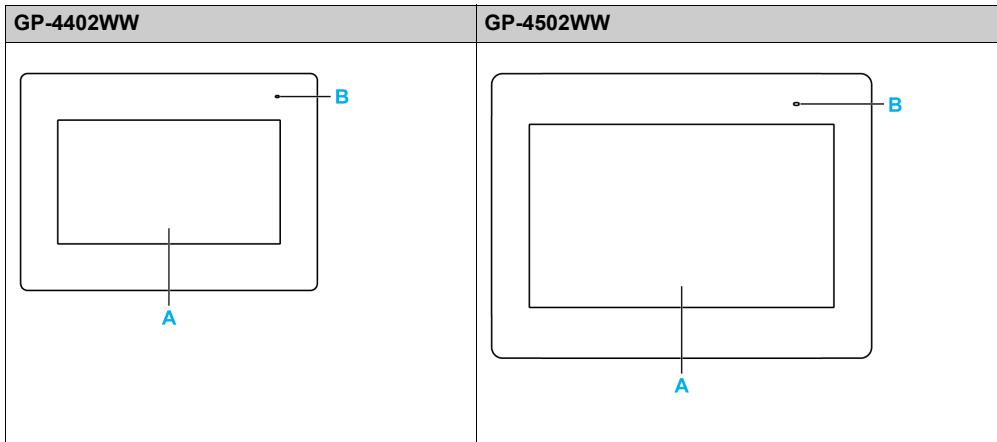

Part	Description
A	Touch panel
B	LED indicator

Rear View

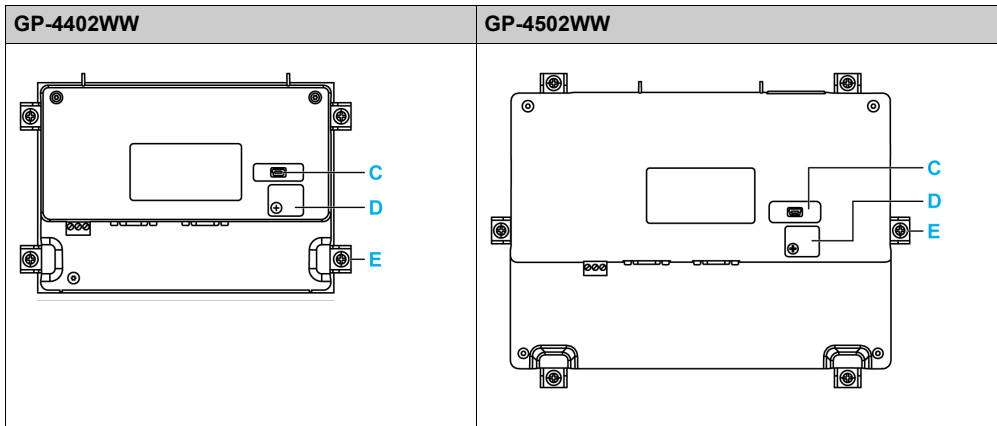

Part	Description
C	USB mini B
D	Locker USB Type A
E	Screw installation fasteners: <ul style="list-style-type: none"> ● GP-4402WW x 4 ● GP-4502WW x 6

Bottom View

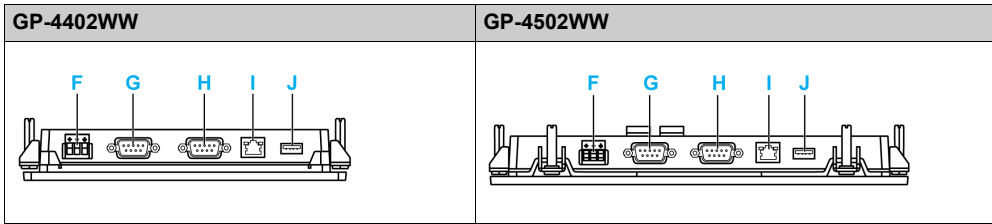

Part	Description
F	Power connector
G	Serial interface RS-232C
H	Serial interface RS-422/485
I	Ethernet
J	USB Type A

Certifications and Standards

Compliance Standards

Pro-face submitted this product for independent testing and qualification by third party listing agencies.

Pro-face and these agencies have certified this product as meeting the following standards:

- Directive 2006/95/EC (Low voltage)
- Directive 2004/108/EC (EMC).

The panels are CE marked.

- EMI: EN61000-6-4
- EMS: EN61000-6-2
- EN61131-2
- IP65 (front face) - IP20 (rear)

Qualification Standards

Pro-face voluntarily tested this product to additional standards. The additional tests performed, and the standards under which the tests were conducted, are specifically identified in Environmental Characteristics (*see page 22*).

Hazardous Substances

The GP-4402WW/GP-4502WW is designed for compliance with:

- REACH, Regulation N°1907/2006 on the Registration, Evaluation, Authorisation of Chemicals

This product is compliant with:

- RoHS European
- RoHS China

Hazardous Location



RISK OF EXPLOSION IN HAZARDOUS LOCATION

Do not use this product in hazardous location.

Failure to follow these instructions will result in death or serious injury.

GP-4402WW/GP-4502WW

Introduction

This topic presents the GP-4402WW/GP-4502WW human-machine interface (HMI) products. The features of the screen technology are color and TFT (Thin Film Transistors also known as active matrix) with WVGA pixel resolution. The operating voltage is 24 Vdc. The products offered in this series have various features and benefits listed below:

- Screen size
- RTC battery
- Communication interfaces

Model Number Configuration

The following describes the configuration of model numbers.

Digit Position	1	2	3	4	5	6	7	8	9	10	11	12	13
	P	F	X	(model)		(series)	(size)	(type)		(LCD)	(touch panel)	(power supply)	-
				GP	4	4: 7" 5: 10"	02: RS-232C and RS-422/485 are available		W: Wide TFT	A: Analog	D: DC	W: Entry model	

Model Numbers

Series	Model Names	Model Numbers
GP4000 Series	GP-4400 Series	GP-4402WW
	GP-4500 Series	GP-4502WW
		PFXGP4402WADW
		PFXGP4502WADW

Global Code

A global code is assigned to every Pro-face product as a universal model number. For more information on product models and their matching global codes, please refer to the following URL.

<http://www.pro-face.com/trans/en/manual/1003.html>

Critical Systems, Alarms, and Handling Requirements

Critical alarm indicators and system functions require independent and redundant protection for hardware and/or mechanical interlocks.

When you cycle power, wait at least 1 second before restoring the power to the panel after it has been turned off. Switching the power OFF and ON quickly can damage the panel.

In the event the screen cannot be properly read, for example, if the backlight is not functioning, it may be difficult or impossible to identify a function. Functions that may present a hazard if not immediately executed, such as a fuel shut-off, must be provided independently of the panel. The design of the control system of the machine must take into account the possibility of the backlight no longer functioning and the operator being unable to control the machine or making mistakes in the control of the machine.

WARNING

LOSS OF CONTROL

- Consider the potential failure modes of control paths in the machine control system design, such as:
 - the possibility of backlight failure,
 - unanticipated link transmission delays or failures,
 - the operator being unable to control the machine,
 - the operator making errors in the control of the machine.
- Provide a means to achieve a safe state during and after a path failure for critical control functions such as emergency stop and overtravel stop.
- Provide separate or redundant control paths for critical control functions.
- Test individually and thoroughly each implementation of the panel for correct operation before service.

Failure to follow these instructions can result in death, serious injury, or equipment damage.

WARNING

UNINTENDED EQUIPMENT OPERATION

- Do not use this equipment as the only means of control for critical system functions such as motor start/stop or power control.
- Do not use this equipment as the only notification device for critical alarms, such as device overheating or overcurrent.

Failure to follow these instructions can result in death, serious injury, or equipment damage.

Handling the LCD Panel

The following characteristics are specific to the LCD panel and are considered normal behavior:

- LCD screen may show unevenness in the brightness of certain images or may appear different when seen from outside the specified viewing angle. Extended shadows, or crosstalk may also appear on the edges of screen images.
- LCD screen pixels may contain black and white-colored spots and the color display may look as if it is changing.
- When the same image is displayed on the panel screen for a long period, an after-image may appear after changing the image. If this happens, turn OFF the panel, wait 1 second, and then restart the panel.
- The panel brightness may decrease when used for a long time in an environment continuously filled with inert gas. To prevent deterioration of panel brightness, regularly ventilate the panel. For more information, please contact your local distributor.

<http://www.pro-face.com/trans/en/manual/1015.html>

NOTE: Change the screen image periodically and try not to display the same image for a long period time.

 CAUTION
SERIOUS EYE AND SKIN INJURY
The liquid in the LCD panel contains an irritant: <ul style="list-style-type: none">● Avoid direct skin contact with the liquid.● Wear gloves when you handle a broken or leaking unit.● Do not use sharp objects or tools in the vicinity of the LCD touch panel.● Handle the LCD panel carefully to prevent puncture, bursting, or cracking of the panel material.
Failure to follow these instructions can result in injury or equipment damage.

If the panel is damaged and any liquid comes in contact with your skin, immediately rinse the area with running water for at least 15 minutes. If the liquid gets in your eyes, immediately rinse your eyes with running water for at least 15 minutes and consult a doctor.

Chapter 2

Device Connectivity

Overview

This chapter presents the equipment that you can connect to the GP-4402WW/GP-4502WW.

What Is in This Chapter?

This chapter contains the following topics:

Topic	Page
System Design	18
Accessories	19

System Design

Introduction

The following diagram presents the most common equipment you can connect to the panel.

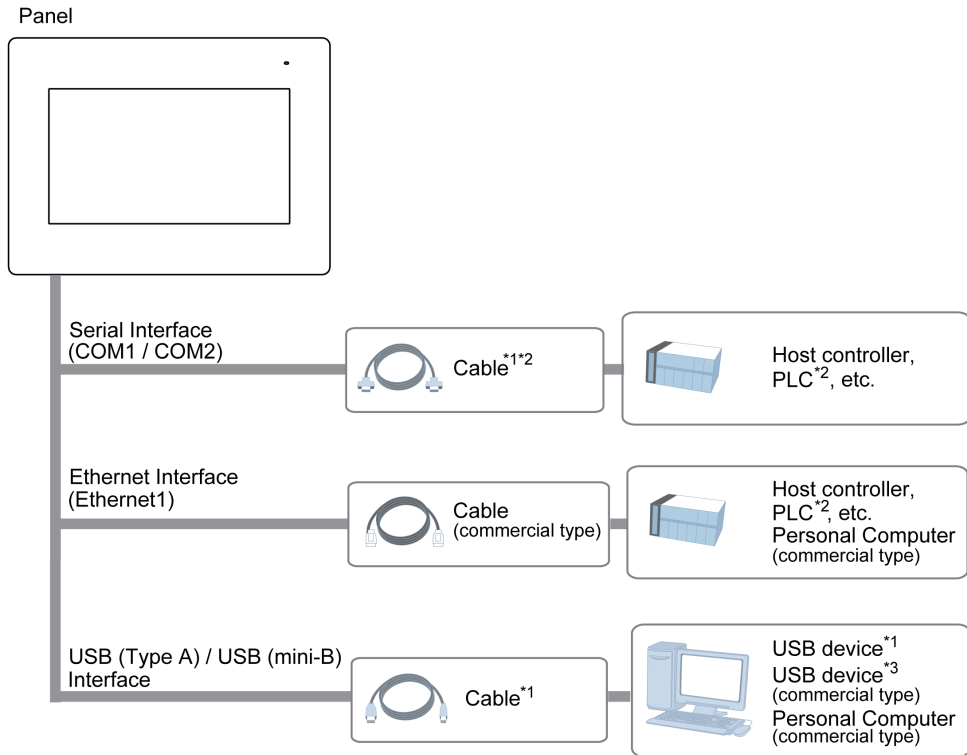

*1 Refer to Accessories (see page 19).

*2 For information on how to connect controllers and other types of equipment, refer to the corresponding device driver manual of your screen editing software.

*3 For supported models, refer to Pro-face's support site "Otasuke Pro!"
<http://www.pro-face.com/otasuke/qa/gp4x02ww/>

Accessories

Serial Interface Items

For host controllers and connection cables, refer to the corresponding device driver manual of your screen editing software.

USB Interface Items

Product name	Model number	Description
USB-Serial (RS-232C) Conversion Cable (0.5 m)	CA6-USB232-01	Cable for converting a USB interface into a serial interface (RS-232C). Allows connection to modems ^{*1} or bar code readers ^{*1} that support RS-232C.
USB Transfer Cable (USB Type A/mini-B) (1.8 m)	ZC9USCBMB1	Cable for transferring screen data from a PC (USB Type A) to this product (USB mini-B).
EZ Illuminated Switch	PFXZCCEUSG1	A unit of 5 illuminated switches with multiple color LED connected to this product via USB.
EZ Fingerprint Recognition Unit	PFXZCCEUSS1	Fingerprint recognition unit connected to this product via USB.
EZ Numpad	PFXZCCEUKB1	Numpad connected to this product via USB.
EZ Tower Light tube mounting with fixing plate	PFXZCETWHA1	USB Connection Type Monolithic EZ Tower Light tube mounting with fixing plate. 3 tiers, Ø60, lighting and flashing with a buzzer.
EZ Tower Light with base mounting	PFXZCETWW1	USB Connection Type Monolithic EZ Tower with base mounting. 3 tiers, Ø60, lighting and flashing with a buzzer.

*1 For supported models, refer to Pro-face's support site "Otasuke Pro!"
(<http://www.pro-face.com/otasuke/qa/gp4x02ww/>)

Option Items

Product name	Model number	Description
7.0-inch Wide Screen Protection Sheet	PFXZCBDS72	Disposable, dirt-resistant sheet for the display (5 sheets/set).
10.1-inch Wide Screen Protection Sheet	PFXZCBDS102	
7-inch Wide UV Protection Sheet	PFXZCFUV72	Ultraviolet protection for display (1 piece).
10-inch Wide UV Protection Sheet	PFXZCFUV102	

Maintenance Options

Product name	Model number	Description
Installation Fastener	PFXZCFAF1	Used to install this product into a solid panel (4 pieces/set).
DC Power Supply Connector	CA5-DCCNM-01	Connector to connect power supply cables (5 pieces/set).
7-inch Wide Installation Gasket	PFXZCCWG7W1	Provides dust and moisture resistance when this product is installed into a solid panel (1 piece).
10-inch Wide Installation Gasket	PFXZCCWG10W1	

Chapter 3

Specifications

Overview

This chapter presents the GP-4402WW/GP-4502WW specifications.

What Is in This Chapter?

This chapter contains the following sections:

Section	Topic	Page
3.1	General Specifications	22
3.2	Functional Specifications	25
3.3	Interface Specifications	28
3.4	Dimensions	35

Section 3.1

General Specifications

Specifications

Specification		Value
Power supply	Rated input voltage	24 Vdc
	Input voltage limits	20.4...28.8 Vdc
	Acceptable voltage drop	≤ 1 ms with lowest input voltage ≤ 10 ms with rated input voltage
	Power consumption	GP-4402WW: 9.2 W GP-4502WW: 10 W
	In-rush current	≤ 50 A ¹
	Voltage endurance between power terminal and functional ground (FG)	1000 Vac 5 mA for 1 min
	Insulation resistance between power terminal and FG.	10 MΩ or higher at 500 Vdc
Physical	Ambient operating temperature (cabinet interior and panel face)	0...50 °C (32...122 °F)
	Storage temperature	-20...60 °C (-4...140 °F)
	Relative humidity	90 % non-condensing
	Air purity (dust)	≤ 0.1 mg/m ³ (3.5 ⁻⁶ oz/ft ³) (non-conductive levels)
	Pollution degree	2
	Corrosive gases	Free of corrosive gases
	Atmospheric pressure	800...1,114 hPa (2,000 m (6,561 ft) or less)
Mechanical	Vibration immunity	IEC 61131-2 ed.3 (07) 5...150 Hz, 3.5 mm (0.38 in) max., 1 g on 3 axes.
	Shock immunity	IEC 61131-2 ed.3 (07) 1/2 sinusoidal pulse for 11 ms, 15 g on 3 axes
	Cooling method	Natural air circulation
Structural	Protection (front panel)	IP 65 - (IEC 60529) Enclosure type 4 indoor use only (UL 50) with screw installation fasteners
	Protection (rear panel)	IP 20 - (IEC 60529)

¹ For in-rush current, the FWHM (full-width, half maximum) value is approximately 50 μs (when exceeding 25 A).

Specification		Value
Electrical	Radiated radio frequency electromagnetic field	10 V/m / 80 MHz...1 GHz, 3 V/m / 1.4 MHz...2 GHz, 1 V/m / 2 GHz...3 GHz, sinus amplitude modulated 80 % / 1 kHz and internal clock frequency
	Electrical fast transient	EN/IEC 61131-2 zone B 2 kV power supply and 1 kV shielded cables
	High energy surges	IEC 61000 - 4 - 5 0.5 kV (Differential mode on power supply) 1 kV (Common mode on power supply)
	Electrostatic discharge immunity	EN/IEC 61131-2 4 kV contact, 8 kV air
¹ For in-rush current, the FWHM (full-width, half maximum) value is approximately 50 μ s (when exceeding 25 A).		

The front face of the panel, installed in a solid panel, has been tested using conditions equivalent to the standards shown in the specification.

CAUTION

EQUIPMENT DAMAGE

- Ensure that the panel is not in permanent and direct contact with oils.
- Do not expose the device to direct sunlight.

Failure to follow these instructions can result in injury or equipment damage.

NOTICE

STORAGE AND OPERATION OUTSIDE OF SPECIFICATIONS

- Store this product in areas where temperatures are within the product's specifications.
- Do not restrict or block this product's ventilation slots.

Failure to follow these instructions can result in equipment damage.

NOTICE

GASKET AGING

- Inspect the gasket periodically as required by your operating environment to keep the initial IP level.
- Change the gasket at least once a year, or as soon as scratches or dirt become visible.

Failure to follow these instructions can result in equipment damage.

Air Quality Requirements

Do not operate or store the panel where any of the following chemicals may evaporate or where these chemicals are present in the air:

- Corrosive chemicals such as acids, alkalines, and liquids containing salt.
- Flammable chemicals such as organic solvents.

 CAUTION
INOPERATIVE EQUIPMENT Do not allow water, liquids, metal, and wiring fragments to enter the panel case. Failure to follow these instructions can result in injury or equipment damage.

Section 3.2

Functional Specifications

Overview

This section presents the GP-4402WW/GP-4502WW functional specifications of the display, memory, and interfaces.

What Is in This Section?

This section contains the following topics:

Topic	Page
Display Specifications	26
Memory, Clock, and Touch Panel	27

Display Specifications

Displays

Specification	GP-4402WW	GP-4502WW
Type	TFT color LCD	
Display size	7"	10"
Resolution (pixels)	800 x 480 (WVGA)	800 x 480 (WVGA)
Active display area (W x H)	154.08 x 85.92 mm (6.066 x 3.382 in)	219.6 x 131.76 mm (8.645 x 5.187 in)
Colors	65,536 colors For details about display colors, refer to the manual for your screen editing software.	
Backlight	White LED (Not user replaceable. When replacement is required, contact your local distributor.)	
Backlight service life	20,000 hours or more (continuous operation at 25 °C [77 °F] before backlight brightness decreases to 50 %) NOTE: To extend the life of the backlight set the panel to standby mode, which automatically turns off the backlight when no touch input is detected within a set time.	
Brightness	16 levels available through the touch panel	

Memory, Clock, and Touch Panel

Memory

This table describes the memory parameters:

Specification	GP-4402WW/GP-4502WW
User application	32 MB
Backup memory	128 KB

Clock

Variations in operating conditions and battery life can cause a clock inaccuracy from -60 seconds to +60 seconds per month.

For systems where this level of precision is insufficient, the user should monitor and make adjustments when required.

Touch Panel

Specification	GP-4402WW/GP-4502WW
Type	Resistive Film (analog)
Resolution	1,024 x 1,024
Service life	1 million switch and 100 thousand slide operations

Multiple touch operations on models with analog-resistive touch panels may cause unexpected inputs around touched positions.

WARNING

UNINTENDED EQUIPMENT OPERATION

Do not simultaneously touch more than two points on the panel.

Failure to follow these instructions can result in death, serious injury, or equipment damage.

Section 3.3

Interface Specifications

Overview

This section presents the interface specifications of the panels.

What Is in This Section?

This section contains the following topics:

Topic	Page
Interface Specifications	29
Serial Interface Specifications RS-232C	31
Serial Interface Specifications RS-422/485	32
Ethernet Port	33

Interface Specifications

Introduction

GP-4402WW/GP-4502WW is provided with serial, USB, and Ethernet interfaces.

Serial Interface RS-232C

This table describes the RS-232C serial interface:

Interface	Description
Serial interface D-Sub9	
Asynchronous transmission	RS-232C
Data length	7 bits or 8 bits
Stop bit	1 bit or 2 bits
Parity	None, odd or even
Data transmission speed	2,400...115,200 bps

Serial Interface RS-422/485

This table describes the RS-422/485 serial interface:

Interface	Description
Serial interface D-Sub9	
Asynchronous transmission	RS-422/485
Data length	7 bits or 8 bits
Stop bit	1 bit or 2 bits
Parity	None, odd or even
Data transmission speed	2,400...115,200 bps, 187,500 bps (MPI)

USB Interface (USB Peripherals)

This table describes the USB Type A interface:

Interface	Description
Host interface	
Maximum current supplied	500 mA
Maximum transmission distance	3 m (9.84 ft) at 1.5/12/480 Mbps
Connector	USB Type A 2.0

USB Interface (Application Download)

This table describes the USB mini-B interface:

Interface	Description
USB interface is used for application download	
Maximum transmission distance	3 m (9.84 ft) at 12 Mbps, no long-term connections
Connector	USB mini-B 2.0
Isolated	None

Ethernet Interface

Refer to Ethernet Port (*see page 33*).

Serial Interface Specifications RS-232C

Introduction

This interface is used to connect GP-4402WW/GP-4502WW to remote equipment, via a RS-232C cable. The connector used is a D-Sub 9-pin male connector.

By using a long PLC cable to connect to the panel, it is possible that the cable can be at a different electrical potential than the panel, even if both are grounded.

The serial port of the panel is not isolated. The SG (signal ground) and the FG (functional ground) terminals are separated inside the panel.

DANGER

ELECTRIC SHOCK

- Make a direct connection between the functional ground (FG) terminal and ground.
- Do not connect other devices to ground through the functional ground (FG) terminal of this device.
- Install all cables according to local codes and requirements. If local codes do not require grounding, follow a reliable guide such as the US National Electrical Code, Article 800.

Failure to follow these instructions will result in death or serious injury.

Serial Interface RS-232C

This table describes COM1 with its D-Sub 9-pin connector for a RS-232C cable.

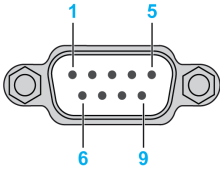
Pin connection	Pin	Signal name	Meaning
	1	CD	Carrier Detect
	2	RD(RXD)	Receive Data
	3	SD(TXD)	Send Data
	4	ER(DTR)	Data Terminal Ready
	5	SG	Signal Ground
	6	DR(DSR)	Data Set Ready
	7	RS(RTS)	Request to Send
	8	CS(CTS)	Send possible
	9	Reserved	–
	Shell	FG	Functional Ground

Any excessive weight or stress on communication cables disconnect communication with the equipment.

CAUTION

LOSS OF COMMUNICATION

- All connections to the communication ports must not put excessive stress on the ports.
- Securely attach communication cables to the panel or cabinet.
- Use only D-Sub 9-pin cables with a locking system in good condition.

Failure to follow these instructions can result in injury or equipment damage.

Serial Interface Specifications RS-422/485

Introduction

This interface is used to connect GP-4402WW/GP-4502WW to remote equipment, via a RS-422/485 cable. The connector used is a D-Sub 9-pin male connector.

By using a long PLC cable to connect to the panel, it is possible that the cable can be at a different electrical potential than the panel, even if both are grounded.

The serial port of the panel is not isolated. The SG (signal ground) and the FG (functional ground) terminals are separated inside the panel.

DANGER

ELECTRIC SHOCK

- Make a direct connection between the functional ground (FG) terminal and ground.
- Do not connect other devices to ground through the functional ground (FG) terminal of this device.
- Install all cables according to local codes and requirements. If local codes do not require grounding, follow a reliable guide such as the US National Electrical Code, Article 800.

Failure to follow these instructions will result in death or serious injury.

Serial Interface RS-422/485

This table describes COM2 with its D-Sub 9-pin connector for a RS-422/485 cable.

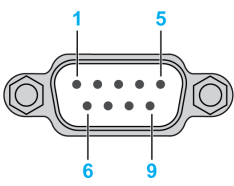
Pin connection	Pin	Signal name	Meaning
	1	RDA	Receive Data A (+)
	2	RDB	Receive Data B (-)
	3	SDA	Send Data A (+)
	4	–	
	5	SG	Signal Ground
	6	–	
	7	SDB	Send Data B (-)
	8	–	
	9	–	
	Shell	FG	Functional Ground

Any excessive weight or stress on communication cables may disconnect communication with the equipment.

CAUTION

LOSS OF COMMUNICATION

- All connections to the communication ports must not put excessive stress on the ports.
- Securely attach communication cables to the panel or cabinet.
- Use only D-Sub 9-pin cables with a locking system in good condition.

Failure to follow these instructions can result in injury or equipment damage.

Ethernet Port

Introduction

The GP-4402WW/GP-4502WW is equipped with an IEEE802.3 compliant Ethernet communication port that transmits and receives data at 10 Mbps or 100 Mbps.

NOTE:

- Ethernet networks must be installed by a trained and qualified person.
- One to one (1:1) connections must be made with a hub or a switch. You can use the 1:1 connection with a cross cable depending on the connected PCs and network cards.

Characteristics

The table describes the different Ethernet characteristics:

Characteristics	Description
Connector type	RJ45
Driver	<ul style="list-style-type: none"> • 10 M half duplex (auto negotiation) • 100 M full duplex (auto negotiation)
Cable type	Shielded
Automatic cross-over detection	Yes

Pin Assignment

The figure shows the RJ45 Ethernet connector pin assignment:

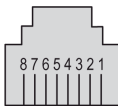

The table describes the RJ45 Ethernet connector pins:

Pin	Signal
1	TD+
2	TD-
3	RD+
4	–
5	–
6	RD-
7	–
8	–

NOTE: The GP-4402WW/GP-4502WW supports the MDI/MDIX auto-crossover cable function. You do not have to use special Ethernet crossover cables to connect devices directly to this port (connections without an Ethernet hub or switch).

Status LEDs

The figure shows the LEDs of the Ethernet connector:

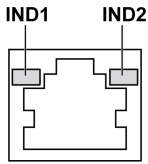

The table describes the Ethernet status LEDs operation:

Label	Description	LED		
		Color	Status	Description
IND1	Ethernet status	Green	Off	No connection or subsequent transmission failure.
			On	Data transmission is available.
IND2	Ethernet activity	Green	Off	No data transmission.
			On	Data transmission is occurring.

Section 3.4

Dimensions

Overview

This section presents the dimensions of GP-4402WW/GP-4502WW.

What Is in This Section?

This section contains the following topics:

Topic	Page
GP-4402WW Dimensions	36
GP-4502WW Dimensions	37
Panel-cut Dimensions	38
Installation Fasteners	39

GP-4402WW Dimensions

Panel Dimensions

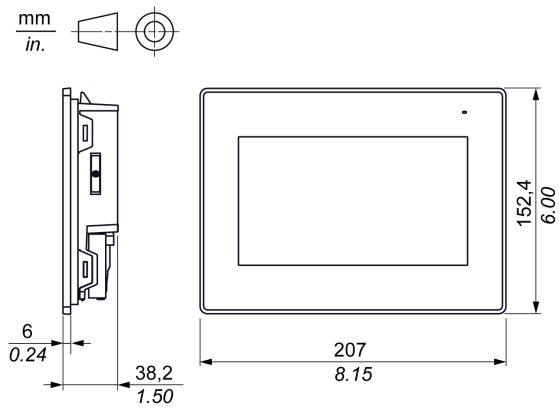

Dimensions with Cables

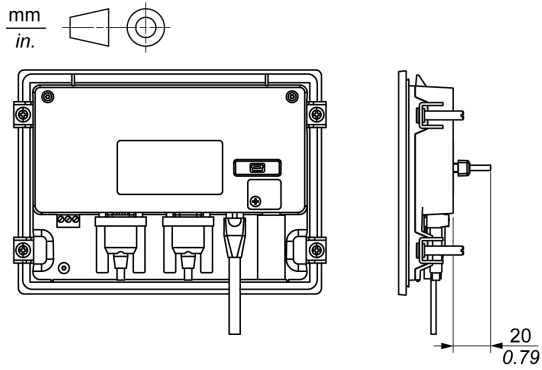

Dimensions with Installation Fasteners

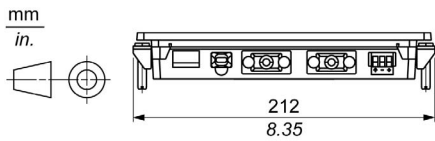

GP-4502WW Dimensions

Panel Dimensions

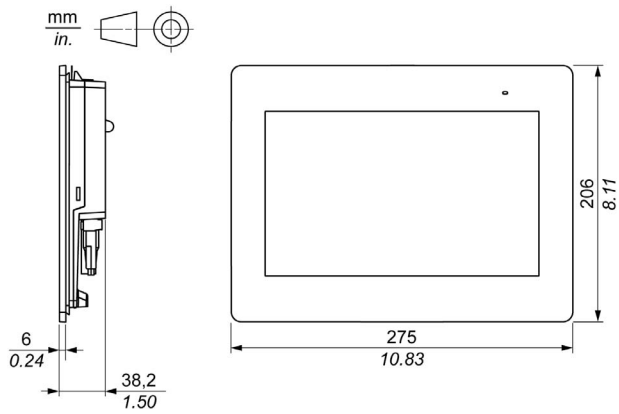

Dimensions with Cables

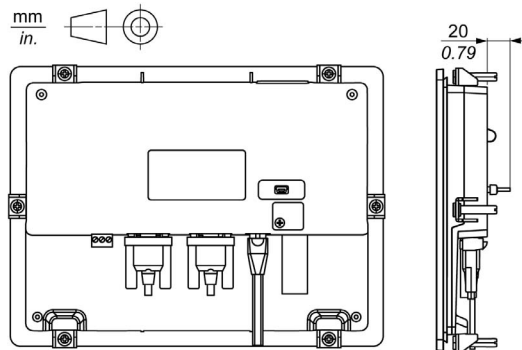

Dimensions with Installation Fasteners

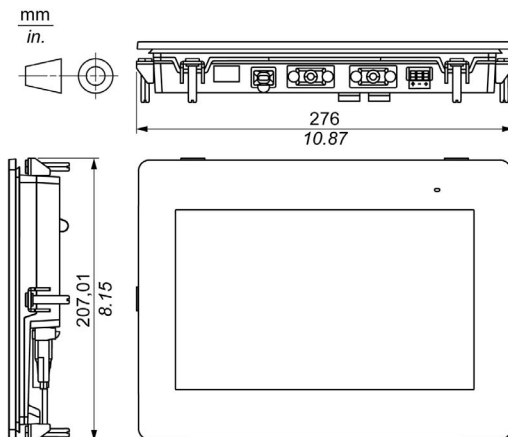

Panel-cut Dimensions

Inserting a GP-4402WW/GP-4502WW

Create a panel-cut and insert the panel from the front. This figure shows the panel-cut for the GP-4402WW/GP-4502WW:

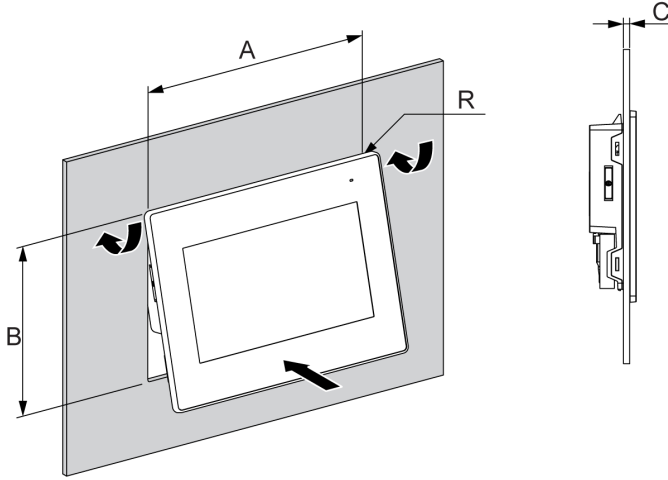

Dimensions

The following table shows the panel-cut dimensions for each panel:

Model	A	B	C (Panel thickness)	R
GP-4402WW	190 ^{±1} mm (7.48 ^{±0.04} in)	135 ^{±0.7} mm (5.31 ^{±0.03} in)	1...5 mm (0.04...0.19 in)	3 mm (0.12 in) max.
GP-4502WW	255 ^{±1} mm (10.04 ^{±0.04} in)	185 ⁺¹ mm (7.28 ^{+0.04} in)	1...5 mm (0.04...0.19 in)	3 mm (0.12 in) max.

Installation Fasteners

Introduction

The fasteners are used to mount the GP-4402WW/GP-4502WW:

Model	Screw installation fasteners
GP-4402WW	4
GP-4502WW	6

Dimensions

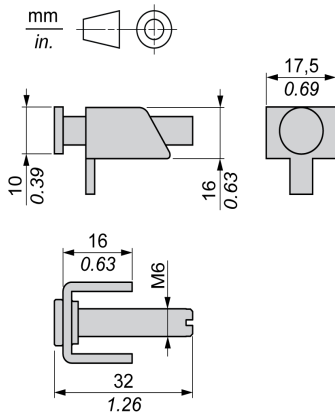

Chapter 4

Installation and Wiring

Overview

This chapter describes the installation procedures and wiring principles for GP-4402WW/GP-4502WW.

What Is in This Chapter?

This chapter contains the following sections:

Section	Topic	Page
4.1	Installation	42
4.2	Wiring Principles	49
4.3	USB Port	55

Section 4.1

Installation

Overview

This section describes the installation procedures for GP-4402WW/GP-4502WW.

What Is in This Section?

This section contains the following topics:

Topic	Page
Installation Procedures	43
Real Time Clock (RTC)	47

Installation Procedures

Introduction

The installation gasket and screw fasteners are required when installing the panel.

Mount the panel in an enclosure that provides a clean, dry, robust, and controlled environment (IP65 enclosure).

NOTE: The protection level of the product may vary from that shown on the label, as the value on the label considers product aging.

An old gasket can lose its dust and drip resistance. Changing the gasket once a year or when scratches or dirt become visible is recommended.

Gasket Setup Requirements

The gasket helps to maintain the protection ratings (IP65, IP20) of the panel, and provides additional protection from vibration.

Step	Action
1	Before installing the panel into a cabinet, check that the installation gasket is securely attached to the panel.
2	A gasket that has been used for a long period may have scratches or dirt on its surface, and could have lost much of its dust and drip resistance. Change the gasket once a year or when scratches or dirt become visible.
3	Make sure that the gasket is inserted into the bottom face of the panel.

Panel Setup Procedure

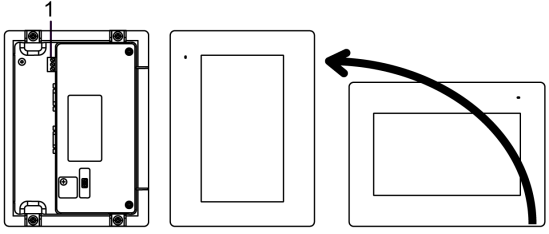
Step	Action
1	Check that the installation panel or the surface of the cabinet is flat, in good condition and has no jagged edges. Metal reinforcing strips may be attached to the inside of the panel wall, near the panel-cut, to increase the rigidity of the panel.
2	Decide on the installation of the thickness of the panel based on the level of panel strength required: 1 mm (0.04 in) to 5 mm (0.19 in).
3	Be sure that the ambient operation temperature and the ambient humidity are within their designated ranges. (When installing the panel in a cabinet or enclosure, the ambient operation temperature is the internal temperature of the cabinet or enclosure.)
4	Be sure that heat from surrounding equipment does not cause the panel to exceed its standard operating temperature (<i>see page 22</i>).
5	When mounting this product vertically, ensure that the right side of this product faces up. In other words, the DC power connector should be at the top. <div style="text-align: center;">  </div>

1 Power connector

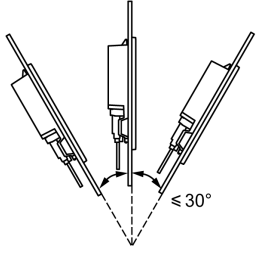
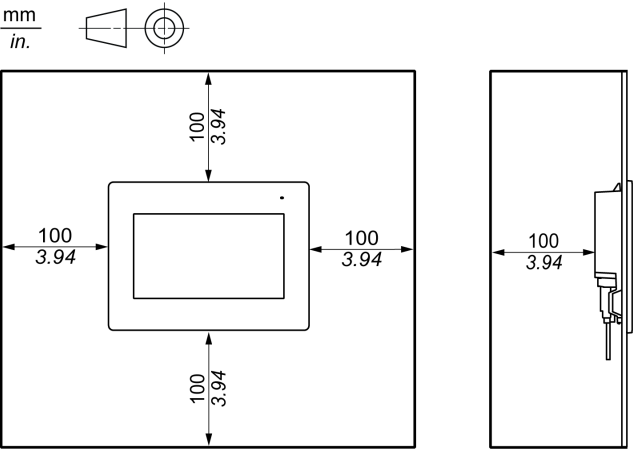
Step	Action
6	<p>When installing the panel in a slanted position, the panel face should not incline more than 30°:</p>  <p>When installing the panel in a slanted position, and the panel face inclines more than 30°, the ambient temperature must not exceed 40 °C (104 °F). You may need to use forced air cooling (fan, A/C) to ensure that the ambient operating temperature is 40 °C or below.</p>
7	<p>For easier maintenance, operation and improved ventilation, install the panel at least 100 mm (3.94 in) away from adjacent structures and other equipment:</p>  <p>mm in.</p>

Panel Mounting Procedure

NOTICE

PANEL UNSTEADY WHEN UNSECURED

Keep panel stabilized in the panel-cut while you are installing or removing the screw fasteners.

Failure to follow these instructions can result in equipment damage.

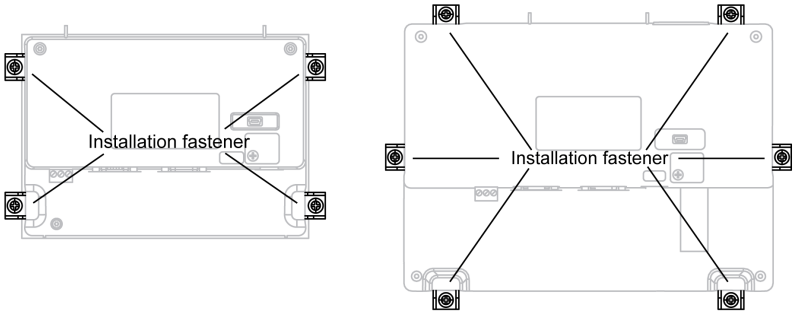
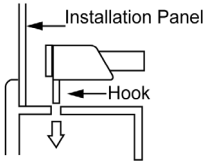
Step	Action
1	Place the panel on a clean and level surface with the display face pointing downward.
2	Check that the installation gasket of the panel is seated securely and runs all the way around the perimeter of the frame.
3	Create the correct sized opening required to install the panel, using the installation dimensions (see page 38).
4	Insert the panel into the panel-cut.
5	Insert the installation fasteners into the panel's insertion slots on the left and right sides (and on the top and bottom sides of the GP-4502WW):
	
6	Slide the fasteners flat against the panel. If the fasteners are not correctly attached, the panel may shift or fall out:
	

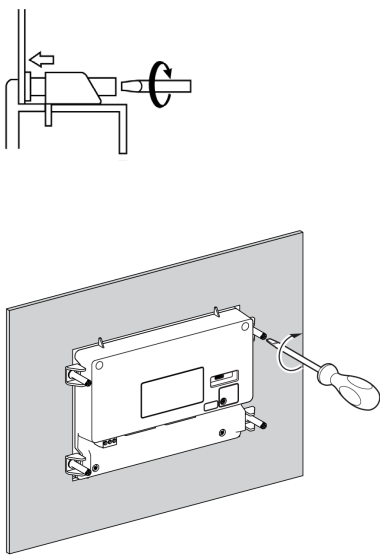
Step	Action
7	<p>Use a Phillips screwdriver to tighten each fastener and secure the panel in place. The necessary torque is 0.8 N·m (7.08 lb-in) maximum:</p> 

NOTICE

BROKEN ENCLOSURE

Do not exert more than 1 N·m (8.85 lb-in) of torque when tightening the fastener's screws.

Failure to follow these instructions can result in equipment damage.

Real Time Clock (RTC)

Overview

GP-4402WW/GP-4502WW includes a RTC to provide system date and time information, and to support related functions requiring a real-time clock. To keep time continuity when power is off, a non-rechargeable but replaceable battery is provided with GP-4402WW/GP-4502WW.

NOTE: After power is disconnected, the GP-4402WW/GP-4502WW cannot retain the time when you change the RTC battery.

Installing and Replacing the RTC Battery

While lithium batteries are preferred due to their slow discharge and long life, they can present hazards to personnel, equipment, and the environment, and must be handled properly.

⚠ DANGER

EXPLOSION, FIRE, OR CHEMICAL HAZARD

Follow these instructions for the lithium batteries:

- Replace with identical type.
- Follow all battery manufacturer's instructions.
- Remove all replaceable batteries before discarding panel.
- Recycle or properly dispose of used batteries.
- Protect battery from any potential short circuit.
- Do not recharge, disassemble, heat above 100 °C (212 °F), or incinerate.
- Use your hands or insulated tools to remove or replace the battery.
- Maintain proper polarity when inserting and connecting a new battery.

Failure to follow these instructions will result in death or serious injury.

NOTE: Replace battery only with identical type: Type BR2032.

To install or replace the RTC battery, follow these steps:

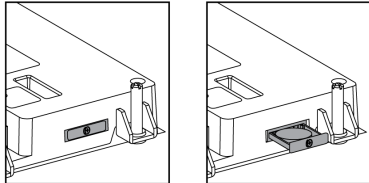
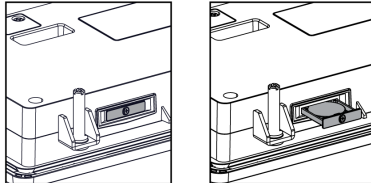
Step	Action
1	Power off your panel.
2	Open the cap to access the backup battery compartment as shown: <div style="display: flex; justify-content: space-around; margin-top: 10px;"> <div style="text-align: center;"> <p>GP-4402WW</p>  </div> <div style="text-align: center;"> <p>GP-4502WW</p>  </div> </div>
3	Remove the used battery from the compartment.
4	Insert the new battery in the compartment in accordance with the polarity markings in the compartment and on the battery.
5	Close the cap.
6	Power up your GP-4402WW/GP-4502WW. NOTE: If you do not power up your GP-4402WW/GP-4502WW immediately, the external backup battery life might be reduced.
7	Set the internal clock. For further details on the internal clock, refer to your screen editing software manual on how to set up the clock.

A lithium battery life is:

- 3 years when the battery's ambient temperature is ≤ 40 °C (104 °F).
- 3 years when the panel's ambient temperature is ≤ 25 °C (77 °F).

Section 4.2

Wiring Principles

Overview

This section presents GP-4402WW/GP-4502WW wiring principles.

What Is in This Section?

This section contains the following topics:

Topic	Page
Connecting the Power Cord	50
Connecting the Power Supply	52
Grounding	54

Connecting the Power Cord

Introduction

Follow these instructions when supplying power to the panel.

- When the functional ground (FG) terminal is connected, be sure that the wire is grounded. If not grounded, the panel can result in excessive Electromagnetic Interference (EMI). Grounding is required to meet EMC level immunity.
- The shield ground (SG) and FG terminals are connected internally in the panel.
- Disconnect the power before wiring the panel's power terminals.
- The panel uses only 24 Vdc power. Using any other level of power can damage both the power supply and the panel.
- Since the panel is not equipped with a power switch, be sure to connect a power switch to the panel's power supply.
- Be sure to ground the panel's FG terminal.

Power Cord Preparation

- Make sure that the ground wire is either the same or heavier gauge than the power wires.
- Do not use aluminum wires in the power supply's power cord.
- If the ends of the individual wires are not twisted correctly, the wires may create a short circuit. To avoid this, use D25CE/AZ5CE cable ends.
- Wherever possible, use wires that are 0.75 to 2.5 mm² (AWG 18 - 12) for the power cord, and twist the wire ends before attaching the terminals.
- The conductor type is solid or stranded wire.

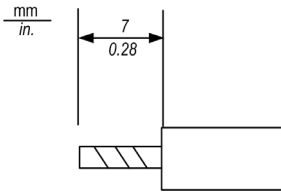

Power Plug Description

Pin connection	Pin	Wire
	+	24 Vdc
	-	0 Vdc
	FG	Grounded terminal connected to the panel chassis.

How to Connect the Power Cord

This figure shows a connection of the power cord:

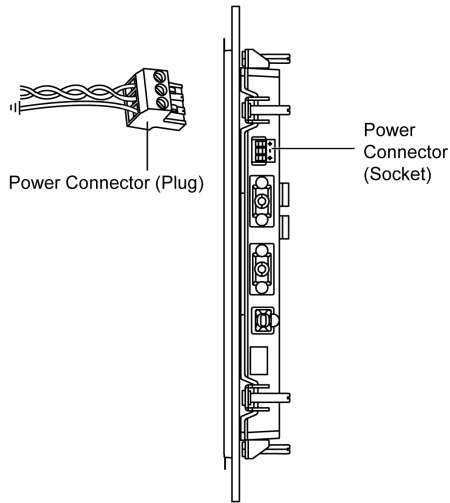

This table explains how to connect the power plug:

Step	Action
1	Remove the power cord from the power supply.
2	Remove the power plug from the panel.
3	Remove 7 mm (0.28 in) of the vinyl cover off the ends of the power cord wires.
4	If using stranded wire, twist the ends. Tinning the ends with solder reduces risk of fraying and ensures good electrical transfer.
5	Connect the wires to the power plug by using a flat-bladed screwdriver (size 0.6 X 3.5).
6	Tighten the mounting screws using the defined torque: 0.5...0.6 N·m (5...7 lb-in).
7	Replace the power plug with the power connector.

NOTE:

- Do not solder the wire directly to the power receptacle pin.
- The power supply cord should meet the specification mentioned above. Be sure to twist the power cords together, up to the power plug, for EMC cancellation.

Connecting the Power Supply

Precautions

Excessive stress on the power connection or attempting to install this product with the power cables connected may disconnect or cause damage to the power connections. This can cause short circuits, fire or unintended equipment operation.

⚡ ⚠ DANGER

SHORT CIRCUIT, FIRE, OR UNINTENDED EQUIPMENT OPERATION

Avoid excessive force on the power cable to prevent accidental disconnection

- Securely attach power cables to an installation panel or cabinet.
- Use the designated torque to tighten this product's terminal block screws.
- Install and fasten this product on installation panel or cabinet prior to connecting power supply and communication lines.

Failure to follow these instructions will result in death or serious injury.

Improving Noise/Surge

- This product's power supply cord should not be bundled with or kept close to main circuit lines (high voltage, high current), power lines, or input/output lines, and their various systems should be kept separate. When power lines cannot be wired via a separate system, use shielded cables for input/output lines.
- Make the power cord as short as possible, and be sure to twist the ends of the wires together (i.e. twisted pair cabling) from close to the power supply unit.
- If there is an excess amount of noise on the power supply line, connect a noise reducing transistor before turning on the power.
- Connect a surge protection device to handle power surges.
- To increase noise resistance, attach a ferrite core to the power cable.

Power Supply Connections

- When supplying power to this product, connect the power as shown below.

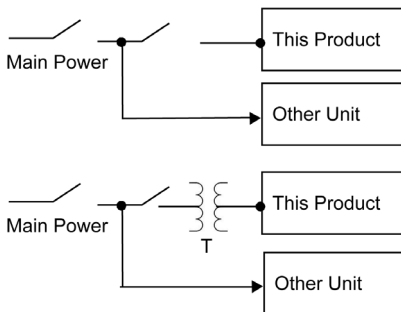

- You must use DC input with a Class 2 power supply for GP-4402WW/GP-4502WW.

- The following shows a surge protection device connection:

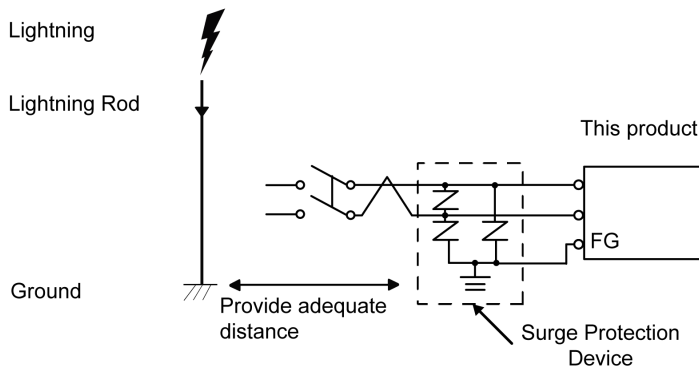

- Attach a surge protection device to prevent damage to this product as a result of a lightning-induced power surge from a large electromagnetic field generated from a direct lightning strike. We also strongly recommend to connect the crossover grounding wire of this product to a position close to the ground terminal of the surge protection device. It is expected that there will be an effect on this product due to fluctuations in grounding potential when there is a large surge flow of electrical energy to the lightning rod ground at the time of a lightning strike. Provide adequate distance between the lightning rod grounding point and the surge protection device grounding point.
- If the voltage variation is outside the prescribed range, connect a regulated power supply.

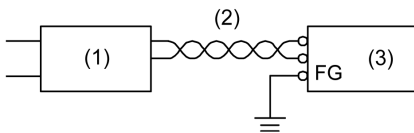

- 1 Regulated power supply
- 2 Twisted-pair cord
- 3 This product

- Select a power supply low in noise for between the line and ground. If there is an excessive amount of noise, connect an insulating transformer. Use isolating transformers with capacities exceeding the maximum power consumption. Refer to "Power consumption" in Specifications (see page 22).

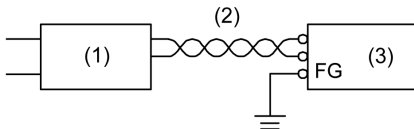

- 1 Insulating transformer
- 2 Twisted-pair cord
- 3 This product

Grounding

Exclusive Grounding

Always ground the FG (functional ground) terminal. Be sure to separate this product from the FG of other devices as shown below.

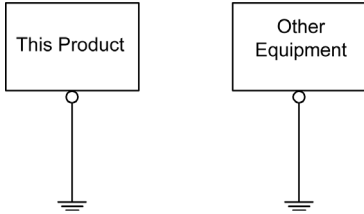

Precautions

- Check that the grounding resistance is $100\ \Omega$ or less.*1
- The FG wire should have a cross sectional area greater than $2\ \text{mm}^2$ (AWG14)*1. Create the connection point as close to this product as possible, and make the wire as short as possible. When using a long grounding wire, replace the thin wire with a thicker wire, and place it in a duct.

*1 Observe local codes and standards.

Common Grounding

Electromagnetic Interference (EMI) can be created if devices are improperly grounded. EMI can cause loss of communication. If exclusive grounding is not possible, use a common grounding point as shown in the configuration below. Do not use any other configuration for common grounding.

Correct grounding

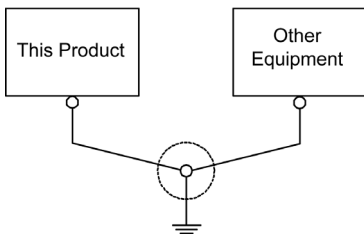

Incorrect grounding

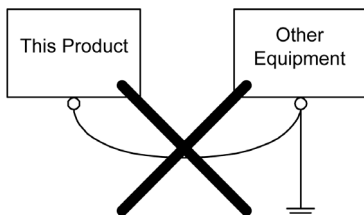

Section 4.3

USB Port

USB Type A Installation

Introduction

When using a USB device, locking the USB interface with the panel helps prevent the USB cable from being disconnected.

The USB locker does not work with the slim type USB memory stick.

Locking the USB

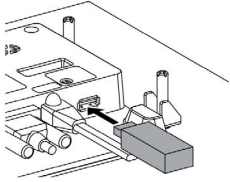
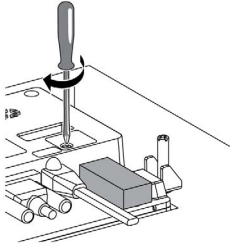
Step	Action
1	Insert the USB cable into the USB host interface: 
2	Lock the USB using a screw driver, torque is 0.5...0.8 N•m (4.42...7.07 lb-in): 

Releasing the USB

Unlock the USB and then remove the USB memory key.

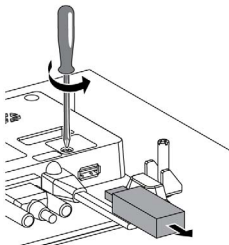

Chapter 5

Maintenance

Overview

This chapter explains how to maintain your GP-4402WW/GP-4502WW.

What Is in This Chapter?

This chapter contains the following topics:

Topic	Page
Precaution	58
Periodic Check Points	59
Regular Cleaning	60
After-sales Service	61

Precaution

Precaution for Long and Safe Use Without Any Breakdowns



Operating the screen with sharp objects may result in damage to the front sheet or the touch panel, and cause abnormal operation. (A switch in a different location from the one you touched may be activated.)



Dropping this product or impacting the screen with excessive pressure may result in breakage of the glass of the touch panel or liquid crystal display. In addition, when mounting this product with the installation fasteners, applying force exceeding the appropriate torque specified in the manual may result in breakage of the front panel.



Using HMI in sunlight or ultraviolet light may shorten the lifetime of the touch panel and may cause the failure of touch functions.



Cleaning the product with chemical agents or allowing penetration of liquids into the product may cause abnormal operation or breakdowns.

NOTICE

EQUIPMENT DAMAGE

- Power off the unit before cleaning it.
- Do not touch the screen with sharp objects when operating this product.
- Do not touch the screen with excessive pressure when operating this product.
- Avoid using HMI in sunlight or ultraviolet light.
- Avoid using chemical agents or allowing liquids to get into this product.

Failure to follow these instructions can result in equipment damage.

Periodic Check Points

Operation Environment

- The operating temperature should be within the allowable range (0...50 °C) (32...122 °F).
- The operating humidity should be within the specified range.
- The operating atmosphere should be free of corrosive gases.

Electrical Specifications

The input voltage should be within 20.4 to 28.8 Vdc.

Related Items

- Are all power cords and cables connected properly? Have any become loose?
- Are all mounting brackets holding the unit securely?
- Are there many scratches or traces of dirt on the installation gasket?

NOTICE

EQUIPMENT DAMAGE

- Do not use hard or pointed objects to operate the touch panel since it can damage the panel surface.
- Do not apply excessive pressure to the panel.
- Do not expose the panel to direct sunlight/ultraviolet rays.
- Do not use paint thinner, organic solvents, or a strong acid compound to clean the unit.

Failure to follow these instructions can result in equipment damage.

Regular Cleaning

Cleaning the Display

NOTICE

EQUIPMENT DAMAGE

- Power off the unit before cleaning it.
- Do not use hard or pointed objects to operate the touch panel, since it can damage the panel surface.
- Do not use paint thinner, organic solvents, or a strong acid compound to clean the unit.

Failure to follow these instructions can result in equipment damage.

When the surface or the frame of the display gets dirty, soak a soft cloth in water with a neutral detergent, wring the cloth tightly, and wipe the display.

Do not use paint thinner, organic solvents, or a strong acid compound to clean the unit.

Cleaning the Gasket

The gasket protects the panel and improves its water resistance.

NOTICE

GASKET AGING

- Inspect the gasket periodically as required by your operating environment to keep the initial IP level.
- Change the gasket at least once a year, or as soon as scratches or dirt become visible.

Failure to follow these instructions can result in equipment damage.

During normal maintenance and reinstallation, check the gasket for dirt and scratches.

Inserting the Gasket

Insert the gasket correctly into the groove to comply with IP65.

After-sales Service

Information

For details on after-sales service, refer to the Pro-face website at:

<http://www.pro-face.com/trans/en/manual/1001.html>

