

## **DANGERS**

### **When Designing your GLC System:**

- Be sure to design your GLC control system so that in the event of a main power supply failure or a GLC accident, the user system's overall safety integrity will be maintained. If this is not done, incorrect output signals or a GLC malfunction may cause an accident.
- (1) Interlock circuits, etc. designed to interrupt or oppose normal machine movement (i.e. Emergency Stop, General Protection, forward and reverse rotation, etc.), as well as those designed to prevent machine damage (i.e. for upper, lower and traverse movement limit positioning, etc.) should all be designed to be located outside of the GLC.
- (2) Whenever the GLC generates a "Watchdog Timer Error", GLC operation will halt. Also, when Errors occur in Input/Output control areas that the GLC cannot detect, it is possible for unexpected movement to occur in those areas. As a result, for the purpose of preventing unsafe machine movement, a "Failsafe Circuit" should be created which is completely external to the GLC.
- (3) If an problem arises with an external unit's relay or transistor, causing an output (coil) to remain either ON or OFF, a major accident can occur. To prevent this, be sure to set up external watchdog circuits that will monitor vital output signals.
- Design a circuit that will supply power to the GLC's I/O unit before starting up the GLC. If the GLC's internal program enters RUN mode prior to the I/O unit's load control power turning ON, an incorrect output (signal) or malfunction could cause an accident to occur.
- Design a user program that will ensure the safety of the user's system, in the event of a GLC display or control error, or in the event of either a data transmission error or power failure between the GLC and a connected unit. These types of problems can lead to an incorrect output (signal) or malfunction, which could thereby cause an accident to occur.
- Do NOT use GLC touch panel switches to perform life-related or important accident prevention operations. These operations should be performed by separate hardware switches to prevent operator injury and machine damage.

## **WARNINGS**

### **Wiring Warnings:**

- To prevent electric shock or equipment damage, prior to installing or wiring the GLC, confirm that the GLC's power cord is unplugged from the power supply.
- After completing any GLC wiring work, be sure the terminal block's protective plastic cover is reattached. If this cover is not reattached, an electric shock could easily occur.
- High voltage runs through the GLC. Except for changing the backlight, do NOT attempt to open the GLC, since there is a possibility of an electric shock.
- Do not use power levels with the GLC that are outside of the GLC's specified power range. Doing so may cause a fire, electric shock or damage the GLC.
- Do not operate or store the GLC in areas where flammable gasses are present, since operating the GLC may cause an explosion.

## **Operation and Maintenance Warnings:**

- Never touch a live power terminal. This could cause a shock or machine malfunction.
- Due to the danger of an electric shock, confirm that the GLC's power cord is unplugged before either cleaning the GLC or attaching/detaching the power terminal screws.
- When replacing the GLC's backlight, be sure to unplug the unit's power cord to prevent a shock, and wear gloves to prevent being burned.
- The GLC uses a lithium battery for backing up its internal clock and control memory data. If the battery is incorrectly replaced (i.e. the + and - sides are reversed), the battery may explode. Therefore, before changing the battery, Digital recommends that you contact your local GLC distributor for battery replacement instructions.
- Do not attempt to modify the GLC's internal parts or wiring in any way, since this may lead to either a shock or fire.

## **CAUTIONS**

### **Wiring Layout Cautions:**

Be sure that all GLC input/output signal lines are isolated from all power wiring or power cables, via a separate wiring duct. This is to prevent excessive noise, which can cause a unit malfunction.

### **Installation Cautions:**

- When attaching the I/O unit to the GLC, be sure that all the I/O unit's attachment screws are used and the unit is securely attached to the GLC. If the I/O unit is not attached securely in place, the I/O unit may be damaged if it falls off the back of the GLC, or a system-related malfunction or accident may occur due to I/O data signal problems.
- Be sure any data cable attached to the GLC's connector is securely attached. If the cable and connector pins do not all make complete contact, incorrect input or output signals can result.

### **General Wiring Cautions**

- To prevent shocks or malfunctions, GLC's FG (earth) wire should be grounded according to the following:
  - 1) A maximum grounding resistance of 100 W or less.
  - 2) A grounding wire of 2mm<sup>2</sup> or larger should be used.
- The GLC's wiring should be checked to confirm both that the operating voltage and wiring terminal locations are correct. If either the voltage or the wiring terminal locations are incorrect, it can cause a fire or accident.
- Be sure to secure all wiring terminal screws in place with the designated torque. Screws and terminals that become loose can cause a short circuit, fire or accident.
- Be sure that metal filings or wiring remnants do not fall inside the GLC, since they can cause a fire, accident, or malfunction.

### **GLC Operation and Maintenance Cautions**

- Be sure to read the GLC's manual and on-line help information carefully before performing program changes, forced output, or utilizing the RUN, STOP or PAUSE commands while the GLC is in operation. Mistakes concerning the use of these items can cause a machine accident or damage.

### **GLC Unit Disposal Cautions**

- The GLC unit should be disposed of in a manner appropriate to the user country's industrial machinery disposal standards.

# UL/c-UL(CSA) Approval

The GLC100-LG41-24V and GLC100-SC41-24V are UL/c-UL(CSA) recognized products. (UL file No.E182139)

■ GLC conforms as a component to the following standards:

- UL508  
Industrial Control Equipment
- UL1604  
Electrical Equipment for Use in Class I and II Division 2 and Class III Hazardous (Classified) Locations
- CAN/CSA-C22.2, Nos.142, and 213-M1987  
Standard for Safety of Information Technology Equipment, including Electrical Business Equipment

GLC100-LG41-24V (UL Registration Model : 0980017-01)

GLC100-SC41-24V (UL Registration Model : 0980017-02)

- The GLC should be installed in the front face of a metal panel.
- If the GLC is installed so as to cool itself naturally, be sure to install it in a vertical panel. Also, be sure that the GLC is mounted at least 100mm away from adjacent structures and other equipment, otherwise, the heat generated by the GLC's internal components may become higher than that allowed by UL standard requirements.

Installation and operation instructions are provided with each GLC. These installation instructions contain the following statements.

1. Power, input and output (I/O) wiring must all be in accordance with Class I, Division 2 wiring methods, Article 501-4 (b) of the National Electrical Code, NFPA 70, or as specified in Section 18-152 of the Canadian Electrical Code for units installed within Canada, and in accordance with that location's authority.
2. Suitable for use in Class I, Division 2, Groups A, B, C and D hazardous location, or nonhazardous locations only.
3. WARNING: Explosion hazard-substitution of components may impair suitability for Class I, Division 2.
4. WARNING: Explosion hazard-do not disconnect equipment unless power has been switched off or the area is known to be nonhazardous.
5. WARNING: Explosion hazard-when in hazardous locations, turn off power before replacing or wiring modules.

# CE Marking

GLC100-LG41-24V, GLC100-SC41-24V are CE marked, EMC compliant products. These units also conform to EN55011 class A, EN50082-2 directives.

# Package Contents

The following items are included in the GLC's package. Prior to using the GLC, be sure to confirm that all the parts shown below are present.

■ **GLC Unit**

( GLC100-LG41-24V / GLC100-SC41-24V )

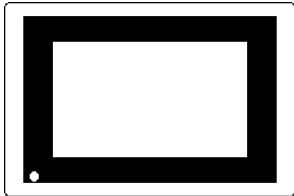

- **Installation fasteners ( 4 pcs )**   ■ **Operation Instructions ( 1 )**  
( this sheet )

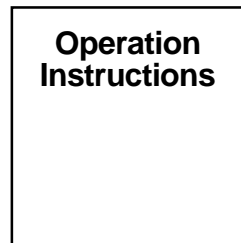
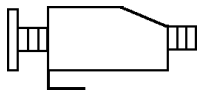

This unit has been carefully packed, with special attention to quality. However, should you find anything damaged or missing, please contact your local GLC distributor immediately.

# GLC Option Items

■ **User's Manual**

(Sold Separately)

GLC100 User's Manual

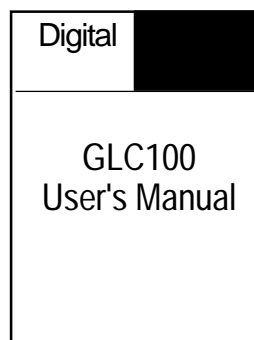

(GLC100-MU41)  
(Japanese Version Only)

■ **Logic Program Development software** (Sold Separately)

Pro-Control Editor



(GLCCNT-ED01J-V10)  
(Japanese Version Only)

# 1 Names and Functions of GLC Parts

The GLC's part names and their functions are explained below.

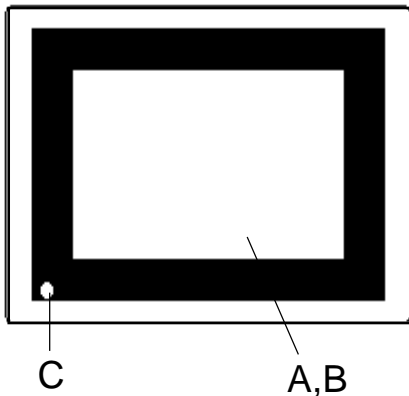

## A: Display

Shows display screens and Host data.  
GLC100-LG41-24V Monochrome LCD  
GLC100-SC41-24V STN-type color LCD

## B: Touch Panel

Performs screen change operations and triggers the sending of data to the PLC.

## C: Power Lamp

Lights when the GLC's power cord is connected to the power supply.

## D: Power Input Terminal Block

Provides power input and grounding terminals for GLC's AC power cord.

## E: Expansion Interface

Used for connecting expansion units to the GLC.

## F: Serial Interface

RS-232C, RS-422 (Serial) interface. Connects the GLC to the Host.

## G: Tool Connector

Connects the Screen Data Downloading Cable, or Bar Code Reader to the GLC.

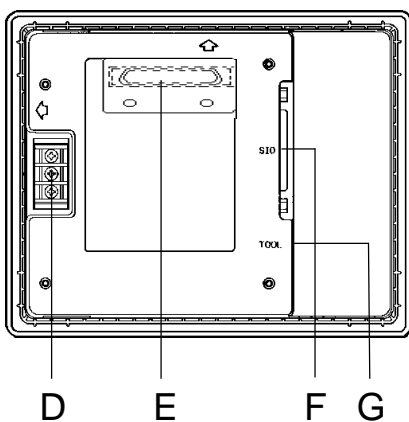

# 2 Dimensions

The GLC100-LG41-24V and GLC100-SC41-24V unit dimensions are as follows.

Unit:mm

## Top View

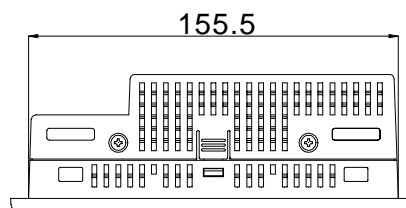

## Front View

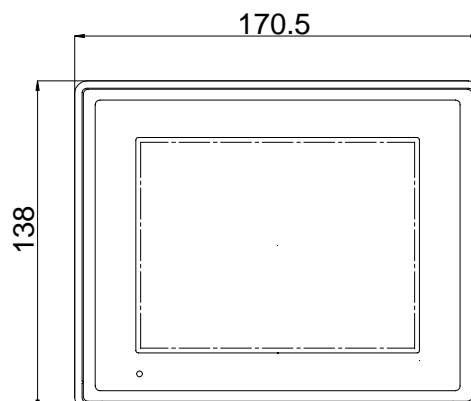

## Side View

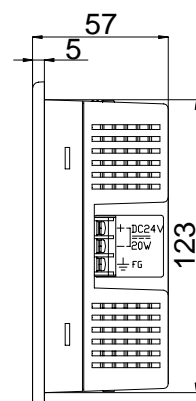

### 3 Serial Interface

This serial port is used for the GLC's RS-232C and RS-422 interface cables.

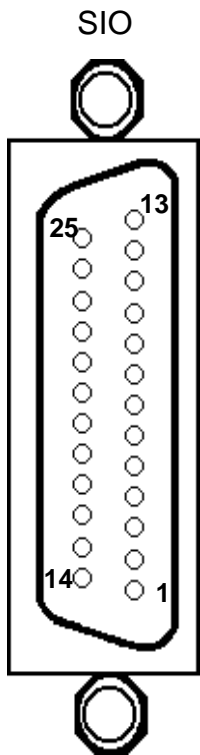

Pin #	Signal Name	Condition	Pin #	Signal Name	Condition
1	FG	Frame ground	14	VCC	5V±5% output 0.25A
2	SD	Send data (RS-232C)	15	SDB	Send data B (RS-422)
3	RD	Receive data (RS-232C)	16	RDB	Receive data B (RS-422)
4	RS	Request send (RS-232C)	17	NC	No connection
5	CS	Clear send (RS-232C)	18	CSB	Clear send B (RS-422)
6	NC	No connection	19	ERB	Enable receive B (RS-422)
7	GND	Signal ground	20	ER	Enable receive (RS-232C)
8	CD	Carrier detect (RS-232C)	21	CSA	Clear send A (RS-422)
9	TRMX	Termination (RS-422)	22	ERA	Enable receive A (RS-422)
10	RDA	Receive data A (RS-422)	23	BUZZER GND	External Buzzer Output
11	SDA	Send data A (RS-422)	24	NC	No connection
12	ALRM OUT	External Alarm Output	25	BUZZER OUT	External Buzzer Ground
13	ALRM GND	External Alarm Ground			

Recommended Connector : Dsub 25 pin plug XM2A-2501 <made by OMRON Corp.>

Recommended Cover : Dsub 25 pin Cover XM2S-2511 <made by OMRON Corp.>

Jack Screw XM2Z-0071 <made by OMRON Corp.>

Recommended Cable : CO-MA-VV-SB5P X 28AWG <made by HITACHI Cable Ltd.>



- When creating a cable, please be aware of the following:

#### <For RS-422 Connections>

- The following pairs of pin #'s must be connected to each other  
 ...#18 (CSB) <-> #19 (ERB)  
 ...#21 (CSA) <-> #22 (ERA)
- When connecting the RS-422 cable and the #9 (TRMX) and #10 (RDA) points, a termination resistance of 100Ω is added between RDA and RDB.
- When the GLC is set as a Memory Link type and the cable type is RS-422, a 4-line system must be used.

#### <For RS-232C connections>

- Do not connect #9 (TRMX), #10 (RDA), #11 (SDA), #15 (SDB), #16 (RDB), #18 (CSB), #19 (ERB), #21 (CSA), and #22 (ERA).



Be sure to connect this unit's SG/GND (Signal Ground) terminal to the other unit's Signal Ground terminal. If necessary, you may also need to connect the FG terminal to the other unit's FG terminal depending on the type of the other unit you use.

This unit's RS-485(RS-422) Port is not isolated, therefore, it is crucial that you connect the SG/GND (Signal Ground) terminals. If this is not done, the RS-485(RS-422) circuit may be damaged.

## 4 Installation



Before installing the GLC, be sure that the moisture resistant gasket is attached securely to the unit.

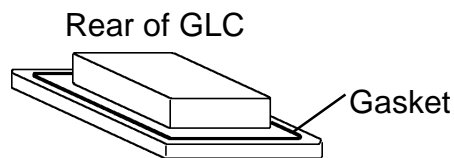

- Cut a hole in the panel, and install the GLC into the panel's front face.

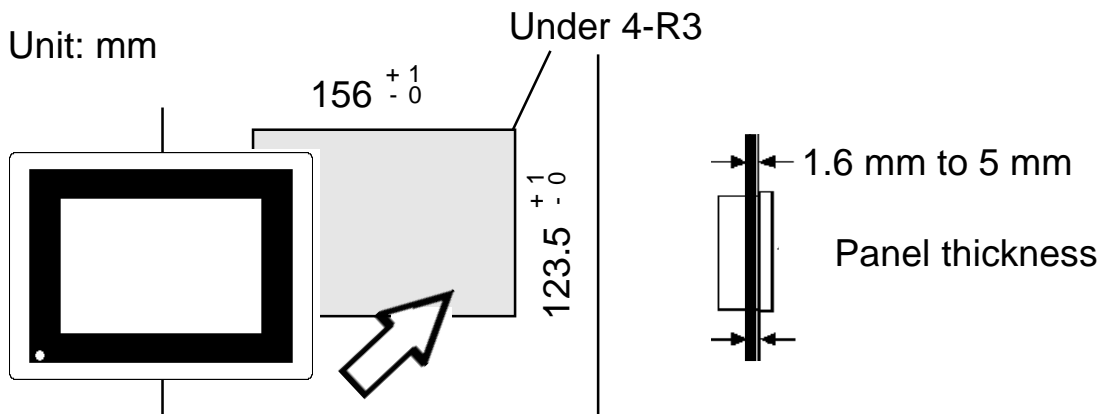

- Attach the Installation Fasteners from the inside of the panel. Tighten all installation fasteners with a screwdriver. To create a waterproof seal, a force of 0.5-0.6N•m is required.

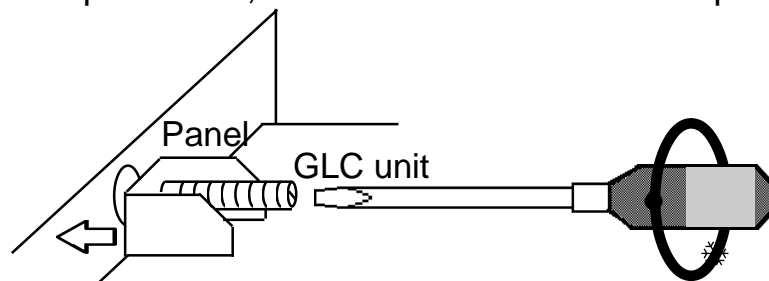

Tightening the screws with too much force can damage the GLC.

## 5 Wiring

### WARNING

- To avoid the possibility of an electric shock, be sure the Power Cord is unplugged from the power outlet prior to connecting the power cord's power terminals to the GLC.
- The GLC100-LG41-24V and GLC100-SC41-24V can only use DC24V input. Any other input voltage can damage the GLC and its power supply.
- Since the GLC has no power switch, be sure to use a breaker type switch.



**When the FG terminal is connected, be sure the wire is grounded. Not grounding the GLC unit will result in excess noise and vibration.**



- Wherever possible, use thick wires (max. 2 mm<sup>2</sup>) for power terminals, and twist the wire ends before attaching the ring terminals.
- Be sure to use the following size Ring Terminals.

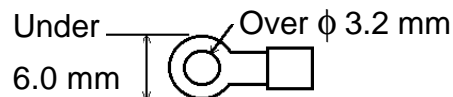

- To prevent a short from occurring when the ring terminals become loose, be sure to use sleeved ring terminals.

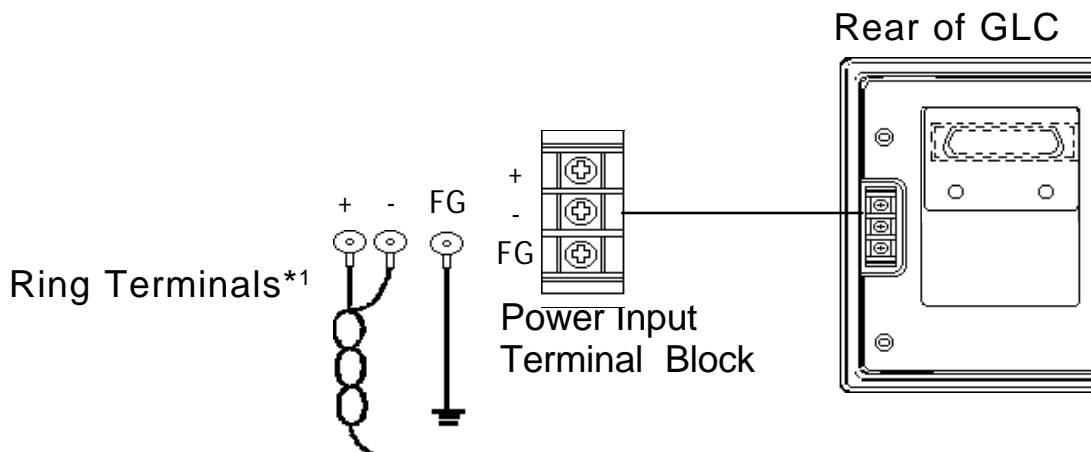

\*1 Recommended Ring Terminals: V2-MS3 (made by JST)

Use the following steps when connecting the Ring Terminals.

1. Confirm that the Power Cord is unplugged from the power supply.
2. Remove the Power Input Terminal Block's plastic cover.
3. Remove the screws from the 3 terminals to be used and align the terminals. Then, re-insert the screws and tighten them in place.

(Be sure the wires are correctly connected)



- The torque necessary for tightening the screws is from 0.5 - 0.6 N•m.



## 6 Grounding Precautions

- From the FG terminal at the rear side of GLC unit, be sure to use exclusive type grounding (resistance of less than 100  $\Omega$ ).
- When attaching an option unit to the GLC, be sure to follow the option unit's operation instructions.

## 7 Input/Output Signal Line Precautions

- GLC input and Output signal lines must be separated from the power control cables used for any and all operation circuits.
- If this is not possible, use a shielded, grounded cable.

## 8 Replacing the Backlight



### WARNING

- Before changing the Backlight, be sure the power cord has been disconnected from the power supply
- While the unit is still hot, be sure to use gloves to prevent burns.
- Do not touch the backlight area while the unit is still ON, since high voltage runs through that area.
- When the GLC's power cord has just been unplugged, the unit is still very hot. Be careful not to be burned.



- Check that you have the proper Backlight for your specific GLC-100 model.

GLC	Backlight Model
GLC100-LG**	GP370-BL00-MS
GLC100-SC**	

When changing the backlight, be sure to wear gloves and use the following steps.

1. Unplug the GLC's power cord from the power supply.
2. Detach the power cord from the GLC. (A)
3. With a screwdriver, unfasten the two screws on the top face of the unit. Press down the top center section to confirm that the cover's catch is released. (B)
4. Insert a screwdriver into the hole at the side of the unit. Then, hold the GLC with one hand and turn the screwdriver to open up the unit from the top. (C)
5. Unplug the Backlight's connector. Do not shift or remove the GLC's internal pad while pulling out the backlight. (D,E)

6. Push the connector clip to the right and pull out the backlight. (F)



- Do not move the clip to the left when removing the back light, since it may break off.

7. Insert the new Backlight, and attach its connector.

8. As shown in the diagram, insert the GLC case's positioning tabs into the alignment holes, close the covers, and fasten the two top-face attachment screws.(G)



- When reconnecting the GLC's covers, be careful not to pinch any of the backlight wiring between the covers.

