

Digital
Human Machine Interface

Pro-face[®]

Flat Panel Display
FP-790T
User Manual

Digital
Digital Electronics Corporation

Preface

Thank you for purchasing Digital's TFT type color display panel, the 'FP-790T'(hereafter referred to as "the FP").

The FP is a TFT type color liquid crystal display monitor for Windows[®] compatible personal computers (VGA, XGA and SVGA modes).

Please read this manual completely to insure the correct use and complete understanding of the FP's functions.

The FP's analog interface is designed to comply with VESA standards. Please be aware that this unit may not be able to be connected with devices using nonstandard VGA interfaces. For further information, please refer to this chapter's "PC Connection Notes" section.

<Note>

- 1) It is forbidden to copy the contents of this manual, in whole or in part, except for the user's personal use, without the express permission of the Digital Electronics Corporation of Japan.
- 2) The information provided in this manual is subject to change without notice.
- 3) This manual has been written with care and attention to detail; however, should you find any errors or omissions, please contact the Digital Electronics Corporation and inform them of your findings.
- 4) Please be aware that the Digital Electronics Corporation is not responsible for any damages resulting from the use of our products, regardless of article 3 above.

All Company/Manufacturer names used in this manual are the registered trademarks of their respective companies.

© Copyright 2001 Digital Electronics Corporation

Essential Safety Precautions

This section describes the safety precautions necessary for the correct use of the FP. Please keep this manual close at hand and refer to it when necessary.

Safety Icons

The following symbols are used throughout this manual to ensure the safe use of the FP. Please be sure to follow all instructions given since they explain important safety points.



This mark warns of a situation that could cause either serious or fatal injury if the instruction is ignored and/or the unit is used incorrectly.



This mark warns of a situation that could cause either personal injury or property damage if the instruction is ignored and/or the unit is used incorrectly.

WARNINGS

- To avoid the possibility of an electric shock, be sure to connect the power cord to the FP before connecting it to the main power supply.
- A fire or electrical shock may occur if voltages used with the FP are beyond the specified range. Be sure to use only the specified voltage.
- Before opening the FP's protective cover, be sure to turn the units power OFF. This is because the FP's internal parts carry high voltages.
- To avoid fires or electrical hazards, do not modify the FP in any way.
- Do not create touch panel switches that are used to either control or to ensure the safety of equipment and personnel. Mechanical switches, such as an emergency stop switch, a deadman (two-handed) start switch, etc., must be installed and operated via a separate control system.
- Do not create touch panel switches which could possibly endanger the safety of humans and equipment. This is due to the possibility of a malfunction in the FP or its cable(s), causing the output of a signal that could result in a major accident. All of a system's major, safety-related switches should be designed to be operated separately from the FP.

WARNINGS

- After the FP's backlight burns out, unlike the FP's "Standby Mode", the touch panel is still active. If the operator fails to notice that the backlight is burned out and touches the panel, a potentially dangerous machine operation mistake can occur.

If your FP's backlight suddenly turns OFF, use the following steps to determine if the backlight is actually burned out.

- 1) If your FP is not set to "Standby Mode" and the screen has gone blank, your backlight is burned out.
 - 2) Or, if your FP is set to Standby Mode, but touching the screen does not cause the display to reappear, your backlight is burned out.
- If metal particles, water or other types of liquids contact any of the FP's internal parts, immediately turn the units power OFF, unplug the power cord, and contact either your FP distributor or the Digital Electronics Corporation.
 - Read and understand Chapter 3 "Installation and Wiring" thoroughly in order to select an appropriate installation location for the FP.
 - Before either plugging in or unplugging a board or interface connector, be sure to turn the FP's power OFF.
 - To prevent a possible explosion, do not install the FP in areas containing flammable gases.
 - The FP is not appropriate for use with aircraft control devices, aerospace equipment, central trunk data transmission (communication) devices, nuclear power control devices, or medical life support equipment, due to these devices inherent requirements of extremely high levels of safety and reliability.
 - When using the FP with transportation vehicles (trains, cars and ships), disaster and crime prevention devices, various types of safety equipment, non-life support related medical devices, etc. redundant and/or failsafe system designs should be used to ensure the proper degree of reliability and safety.



CAUTIONS

- Do not push on the FP's screen too strongly, with either your finger or with a hard object. Excessive pressure can scratch, crack or damage the screen.
- Do not use a pointed object, such as a mechanical pencil or screw-driver, to press any of the touch panel's switches, since they can damage the display.
- If the screen becomes dirty or smudged, moisten a soft cloth with diluted neutral detergent, wring the cloth well, and wipe the display. Do not use thinner or organic solvents.
- Avoid exposing the FP to, or operating the FP in direct sunlight, high temperatures and humidity, and in areas where excessive dust and vibration will occur.
- Avoid using the FP in areas where sudden, extreme changes in temperature can occur. This may cause con-densation to form inside the unit, possibly leading to an accident.
- To prevent the FP from overheating, be sure its air circulation vents are clear and clean, and keep the unit's operation area well-ventilated.
- Avoid operating or storing the FP near chemicals, or where chemicals can come into contact with the unit.

■ About the FP's Display Panel

- The FP's currently displayed data, its voltage and brightness setting each affect the intensity of Contouring. (i.e, when some parts of the screen are brighter than others, creating a wavelike pattern)
- There are minute grid-points (dark and light) on the Display Panel's surface. This is part of the FP's design and not a defect.
- Shadows may appear at the top of the LCD. This is normal for an LCD display.
- Sometimes the display area may look as if the display colors have changed. This is a common attribute of LCD's and is not a defect.
- Displaying a single image for long periods can cause an afterimage to remain when the display is changed to another screen. To prevent this, periodically turn the FP OFF and then ON again to remove this afterimage.

Table of Contents

Preface	1
Essential Safety Precautions	2
Table of Contents	5
CE Marking Notes	7
PC Connection Notes	7
FP-790T Features	8
Package Contents	9
Symbol Information	10

Chapter 1—Introduction

1-1 Connecting the FP to a PC	1-1
1-2 Optional Equipment	1-3

Chapter 2—Specifications

2-1 General Specifications	2-1
2-1-1 Electrical Specifications	2-1
2-1-2 Structural Specifications	2-1
2-1-3 Environment Specifications	2-2
2-1-4 Touch Panel Specifications	2-2
2-1-5 External Interface Specifications	2-3
2-2 Functional Specifications	2-3
2-2-1 Display Specifications	2-3
2-3 Interface Specifications	2-4
2-3-1 Analog RGB Interface	2-4
2-3-2 RS-232C Interface	2-5
2-3-3 Mouse Connector	2-6
2-3-4 Mouse Type Host Connector	2-6
2-4 Option Cable Pin Diagrams	2-7
2-5 Parts Names and Functions	2-9
2-6 Dimensions	2-10
2-6-1 FP-790T External Dimensions	2-10
2-6-2 Installation Fasteners	2-11
2-6-3 Panel Cut Dimensions	2-10

Chapter 3—Installation and Wiring

3-1 Installation	3-1
3-1-1 Installation Procedures	3-1
3-2 Wiring	3-4
3-2-1 Power Cable Connection Precautions	3-4
3-2-2 FP Power Cable Connection Procedures	3-6
3-2-3 FP Power Supply Connection Procedures	3-7
3-2-4 FP Grounding Cautions	3-7
3-2-5 FP Input/Output Signal Line Cautions	3-7
3-3 Setup of Operation Mode and Positioning of Display	3-8
3-3-1 Operation Mode Setup and Adjustment	3-8
3-4 Screen Adjustment using OSD	3-10

Chapter 4—Touch Panel Commands

4-1 Command List	4-1
4-2 Touch Panel Data Input	4-3
4-3 Boot-up Initialization	4-7

Chapter 5—Troubleshooting

5-1 Troubleshooting	5-1
5-1-1 Possible Device Problems	5-1
5-1-2 No Display	5-2
5-1-3 The Touch Panel Does Not Function	5-4

Chapter 6—Maintenance

6-1 Cleaning the FP's Display	6-1
6-2 Periodic Check-Up	6-2
6-3 Changing the Backlight	6-3

CE Marking Notes

The FP-790T is a CE marked, EC compliant product.

<Complies with the following Standards>

- Safety (EN60950)
- EMI (EN55011 class A), EN61000-3-2, EN61000-3-3
- EMS (EN61000-6-2)

PC Connection Notes

The FP's analog RGB interface offers normal display performance within the following ranges:

VESA standard display mode	Size	Horizontal frequency	Vertical frequency	Dot clock frequency	Sync Logic V.H
VGA	640×480	31.469 kHz	59.992 Hz	25.175 MHz	-,-
		37.500 kHz	75.000 Hz	31.500 MHz	-,-
SVGA	800×600	37.879 kHz	60.317 Hz	40.000 MHz	+,+
		46.875 kHz	75.000 Hz	49.500 MHz	+,+
XGA	1024×768	48.363 kHz	60.004 Hz	65.000 MHz	-,-
		56.476 kHz	70.069 Hz	75.000 MHz	+,+
		60.023 kHz	75.029 Hz	78.750 MHz	+,+
US Text	720×400	31.469 kHz	70.087 Hz	28.322 MHz	+,-
		37.927 kHz	85.039 Hz	35.500 MHz	+,-



- **The allowable frequency fluctuation range in both the horizontal and vertical frequencies is +/- 1%. If fluctuations exceed these ranges, the FP will enter power save mode and the display will go blank.**
- **Be sure to turn FP-790T and PC ON at the same time, or before turning PC ON. If PC is turned ON first, a touch panel and an external mouse will not work.**

Since some commercially-available video interface equipment also accommodates tracking ranges in excess of those shown above, they may not offer normal display performance when used with the PC. Before using a video interface, be sure to check its specifications.

Also, even if the same type personal computer is used to transfer data to the PC, the above mentioned problems can also occur when the PC's video board is replaced.

While the FP('s OS) is starting up, please do not touch the screen's touch panel.

FP-790T Features

- **Large-sized, high-quality color LCD**

The monitor uses a 14.1 inch TFT type color LCD, and the 260,000 display colors allow a wide variety of screen designs. The features of this display are easy-to-read images and text, wide view angle, high contrast, and fast response.

- **FP's large-sized display is XGA mode compatible**

The FP is compatible with XGA mode, allowing a large variety of information to be displayed.

- **Display mode is automatically selected (Multi-scan)**

The FP's multi-scan feature automatically selects the display mode, according to the host's display mode (VGA, SVGA, XGA or US Text).

- **PC data can be displayed on the FP**

Since the FP is connected to the host through an analog RGB interface, it can also be easily connected to a personal computer and used as a display.

▼Reference▲ For the available display modes, see “*PC Connection Notes*”

- **Rear-mounting type is designed to be built into other equipment**

The slim and compact body is designed specifically to be built into machine cabinets and panels. Since the FP can be easily used with other equipment, it can be used as a monitor for your PC-based Industrial Automation system. Also, the FP front panel's installation gasket provides a dust and drip-resistant seal between the FP's front face and the installation panel. Thus, the FP can be used even in harsh industrial environments.

- **Touch panel can be operated while PLC data is monitored (Standard feature)**

The FP's touch panel is standard equipment and is suitable for monitoring systems that require touch operations.

Package Contents

The FP's packing box contains the items listed below. Please check to be sure each is included and is not damaged.

FP unit (FP790-T21)

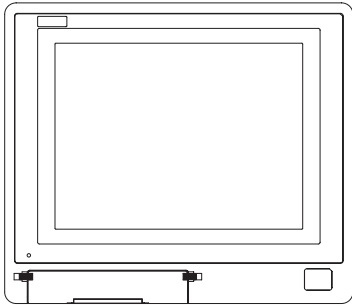

FP-790T Installation Guide

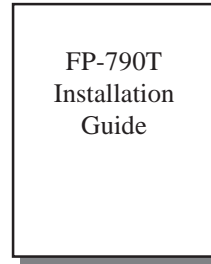

CD-ROM *1
(contains the PDF manuals)



Installation brackets (12)
<GP070-AT01>

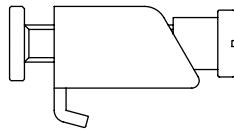

Installation gasket
<FP790-WP00>





These items have all been carefully packed with special attention to product quality. However, should you find any item(s) damaged or missing, please contact your local distributor immediately for prompt service.

*1 For description and usage of the application programs stored in the floppy disk, see that disk's English "READ_ME.DOC" file.

Symbol Information

The list below describes the symbols used in this manual.

Symbol	Meaning
	Used to indicate important information or procedures that must be followed for correct and risk-free software/device operation.
	Used to refer to useful or important supplemental information.
	Used to provide useful or important supplemental information.
*1	Used to provide useful or important supplemental information.
1) , 2)	Indicates steps in a procedure. Be sure to perform these steps in the order given.

Chapter 1

Introduction

1. Connecting the FP to a PC
2. Optional Equipment

The following diagram illustrates the connection options available between the FP and a PC.

1-1 Connecting the FP to a PC

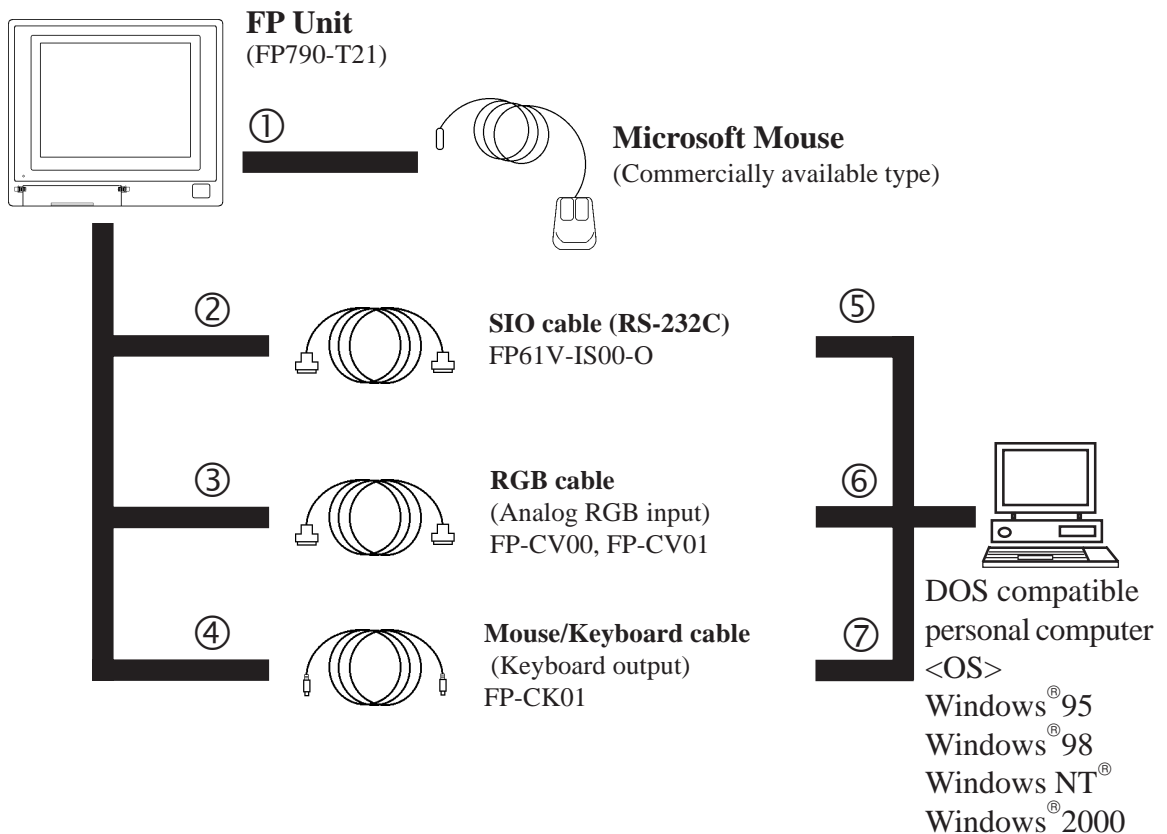

Reference For a description of each reference no. used (⑥, etc.) refer to the next page (page 1-2)





The interface connecting a touch panel to a host PC is only RS-232C. It cannot be communicated with the PS/2 interface.

Introduction

Optional Parts

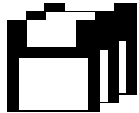
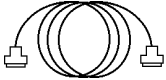
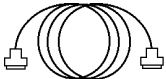
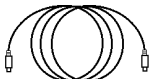

(Sold separately)

	FP-790 Mouse Emulator for Windows FP-ME000*1
	Analog RGB Cable FP-CV00/FP-CV01
	Serial I/F Cable FP61V-IS00-0
	Mouse/Keyboard Cable FP-CK01
	Display Protection Sheets (5 sheets/set) PL-CS500

*1 The FP-ME000 (Mouse Emulator) can only be used with a PC running the Japanese version of Windows. When an English version of Windows is used, the English version of the U-TP (Gunze Corporation) software is required. For purchasing information, contact your local Pro-face distributor.

Optional Maintenance Parts

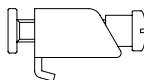
These parts are included in either the FP or its package as standard equipment, and are also optionally available for FP maintenance.

	Backlight (2 lights/set) FP790T-BL00-MS
	Installation Brackets (4 brackets/set) GP070-AT01
	Installation Gasket FP790-WP00

Page 1-1 Item Description

FP Interface

- ① Mouse Connector
- ② Serial I/F Connector
- ③ Analog RGB I/F Connector
- ④ Host Connector for Mouse

Personal Align Computer Interface

- ⑤ Mouse interface
- ⑥ Serial interface
- ⑦ Analog RGB interface

Reference 2-5 Names and Functions of FP Parts

1-2	Optional Equipment
------------	---------------------------

All optional equipment listed below are products of Digital Electronics Corp.

Item Name		Model No.	Description
Interfaces	SIO cable	FP61V-IS00-O	Serial interface cable used for transmission of touch panel data between the FP and various hosts (PCs), and for the transmission of commands to the FP. (5 m) Compatible with PC/AT (D-sub 9-pin female connector) computers
	RGB cable (2.5m)	FP-CV00	Analog RGB interface cable used to output image signals from various host (PCs) to the FP. (2.5 m) Compatible with analog RGB interface (D-sub 15-pin male connector).
	RGB cable (5m)	FP-CV01	Analog RGB interface cable used to output image signals from various host (PCs) to the FP. (5 m) Compatible with analog RGB interface (D-sub 15-pin male connector).
	Mouse/Keyboard cable	FP-CK01	Used to connect a mouse between the host and the FP. (2.5 m) Compatible with PS-2 (mini DIN 4-pin male connector) devices. A keyboard cannot be connected.
Optional Software	FP-790 Mouse Emulator	FP-ME000*1	Touch panel driver for Windows95, 98, NT, 2000
Maintenance Parts	Backlight	FP790T-BL00	Replacement Backlights (2 lights/set)
	Installation brackets	GP070-AT01	Used to secure the FP to its installation panel. (4 brackets/set)
	Installation gasket	FP790-WP00	Used to prevent moisture from entering the FP's chassis. Same gasket as originally included with the FP.
Optional Parts	Display protection sheets	FP77-COVER-5P	Disposable sheets that protect the display from dust and dirt. The touch panel can be used when one of these sheets is attached. (5 sheets/set)

*1 The FP-ME000 (Mouse Emulator) can only be used with a PC running the Japanese version of Windows. When an English version of Windows is used, the English version of the U-TP (Gunze Corporation) software is required. For purchasing information, contact your local Pro-face distributor.

MEMO

Chapter 2

Specifications

1. General Specifications
2. Functional Specifications
3. Interface Specifications
4. Option Cable Pin Diagrams
5. Names and Descriptions of FP Parts
6. Flat Panel (FP) Dimensions

This chapter includes general specifications, functional specifications, interface specifications, and part names and dimensions of the FP.

2-1 General Specifications

2-1-1 Electrical Specifications

Input Voltage	AC 100V to AC 240V 50/60Hz
Rated Voltage	AC 85V to AC 265V 50/60Hz
Allowable Voltage Drop	1 cycle or less
Power Consumption	65VA or less
In-Rush Current	30A (at normal temperature), 45A (at 40°C)
Voltage Endurance	AC 1500V 20mA 1 minute (between the live wire and grounding terminals)
Isolation Resistance	DC 500V 10M Ω greater (between the live wire and grounding terminals)

Specifications

2-1-2 Structural Specifications

Grounding	100Ω or less, or your country's applicable standard
Cooling Method	Natural air circulation
Weight	6.5kg [14.3lbs.] or less (Unit only)
External Dimensions	W405mm [15.94in.] x H350mm [13.78in.] x D75mm [2.95in.] (not including rear projections)
Ratings^{*1}	Equivalent to IP65f (JEM 1030)

**1 The front face of the FP unit, installed in a solid panel, has been tested using conditions equivalent to the standard shown in the specification. Even though the FP unit's level of resistance is equivalent to the standard, oils that should have no effect on the FP can possibly harm the unit. This can occur in areas where either vaporized oils are present, or where low viscosity cutting oils are allowed to adhere to the unit for long periods of time. If the FP's front face protection sheet becomes peeled off, these conditions can lead to the ingress of oil into the FP and separate protection measures are suggested. Also, if non-approved oils are present, it may cause deformation or corrosion of the front panel's plastic cover. Therefore, prior to installing the FP be sure to confirm the type of conditions that will be present in the FP's operating environment.*

If the installation gasket is used for a long period of time, or if the unit and its gasket are removed from the panel, the original level of the protection cannot be guaranteed. To maintain the original protection level, you need to replace the installation gasket regularly.

2-1-3 Environmental Specifications

Operating Temperature	0°C to 40°C
Storage Temperature	- 10°C to 60°C
Ambient Humidity	30%RH to 85%RH (non-condensing)
Dust	0.1mg/m ³ or less (non-conductive levels)
Atmosphere	Free of corrosive gases
Atmospheric Endurance	800hPa to 1114hPa (2000 meters or lower)
Vibration Resistance	10Hz to 25Hz (X, Y, Z directions: 30 minutes each, 19.6m/s ²)
Noise Immunity (via noise simulator)	Noise Voltage : 1500Vp-p Pulse Duration : 50ns, 500ns, 1μs Rise Time : 1 ns
Electrostatic Discharge Immunity	4kV IEC 61000-4-2

2-1-4 Touch Panel Specifications

Resolution (dot)	1024 X 1024
Method	Resistive Film (Analog)

2-1-5 Display Specifications

Analog RGB I/F (RGB IN)	Input Signal	Analog RGB
	Image Signal	Analog RGB
	Synchronous Signal	TTL Level, negative True or positive true
	Scanning Type	Non-interlaced
	Display Adjustment	Clock adjustment: -128 to 128
		Phase adjustment: 64 levels
	Contrast Control	via touch panel
	Brightness Control	via touch panel
	Color Control	via red, green, blue settings
Positioning control	Horizontal Display	
	Vertical Display	
Serial I/F (RS-232C)	Asynchronous Transmission, RS232C, Data Length: 8 bits, Stop Bit: 1, Parity: None, Odd or Even, Transfer Speed: 9600bps	
Mouse I/F	(MOUSE IN)	PS/2 Interface mini DIN 6-pin female
	(MOUSE OUT)	PS/2 Interface mini DIN 4-pin female

2-2 Functional Specifications

2-2-1 Display Specifications

Display Media	TFT color LCD
Display Colors	260,000
Contrast Adjustment	Possible via adjustment menu
Dot Pitch	W0.273mm x H0.273mm
Touch Panel Resolution	1024 x 1024
Display Area	285.7mm [11.25 in.] x 214.3mm [8.44 in.]
Display Mode (selected via switch)	640 x 480 (VGA) 720 x 400 (US Text) 800 x 600 (SVGA) 1024 x 768 (XGA)
Backlight	CFL (under continuous 24 hour operation, lifespan = 30,000 hours)

Specifications

2-3 Interface Specifications



Be sure to use Proface's optional cable. If any other cable is used, due to possible noise interference, Proface cannot guarantee the FP will perform as specified.

2-3-1 Analog RGB Interface (RGB IN)

Pin No.	Signal Name	Condition	Pin Location
1	ANALOG R	R Signal Input	
2	ANALOG G	G Signal Input	
3	ANALOG B	B Signal Input	
4	NC	No Connection	
5	GND	GND	
6	RETURN R	R Signal GND	
7	RETURN G	G Signal GND	
8	RETURN B	B Signal GND	
9	NC	No Connection	
10	GND	GND	
11	NC	No Connection	
12	NC	No Connection	
13	H. SYNC	Horizontal Synchronous Signal Input	
14	V. SYNC	Vertical Synchronous Signal Input	
15	NC	No Connection	

Recommended Connector: Mini Dsub 15 pin (JST Co.) KEY-15S-2A3F equivalent
Connector set screw: Inch type (4-40UNC)
Cable: Digital Electronics Corporation RGB cable (FP-CV00, FP-CV01)

VESA Standard Display Mode	Size	Horizontal Frequency	Vertical Frequency	Dot Clock Frequency	Sync Logic V.H
VGA	640×480	31.469 kHz	59.992 Hz	25.175 MHz	-,-
		37.500 kHz	75.000 Hz	31.500 MHz	-,-
SVGA	800×600	37.879 kHz	60.317 Hz	40.000 MHz	+,+
		46.875 kHz	75.000 Hz	49.500 MHz	+,+
XGA	1024×768	48.363 kHz	60.004 Hz	65.000 MHz	-,-
		56.476 kHz	70.069 Hz	75.000 MHz	+,+
		60.023 kHz	75.029 Hz	78.750 MHz	+,+
US Text	720×400	31.469 kHz	70.087 Hz	28.322 MHz	+, -
		37.927 kHz	85.039 Hz	35.500 MHz	+, -



The allowable frequency fluctuation range in both the horizontal and vertical frequencies is +/- 1%. If fluctuations exceed these ranges, the FP will enter power save mode and the display will go blank.

2-3-2 RS232C Interface (COM1/COM2/COM3)

Pin Assignments and Signal Names for Serial Interface Connector

Pin No.	Signal Name	Condition	Pin Location
1	CD	Carrier Detect (FP → Host)	
2	RD	Receive Data (FP → Host)	
3	TD	Send Data (FP ← Host)	
4	DTR	Data Terminal Ready (FP ← Host)	
5	GND	Ground	
6	DSR	Data Set Ready (FP → Host)	
7	RTS	Request to Send (FP ← Host)	
8	CTS	Clear to Send (FP → Host)	
9	RI	Not Used	

Recommended Connector: Mini Dsub 9-pin (JST Co.) JEY-9P-1A3F equivalent
Connector set screw: Inch type (4-40UNC)
Cable: Digital Electronics Corporation SIO cable (FP-61V-IS00-0)



- Since all serial interface signals are the same on the PC side, use a straight cable to connect the FP to the PC.
- The GND terminal is the signal ground. Be sure to connect the GND terminal to other unit's SG (signal ground).

Signal Names

Signal names used for the FP's serial interface are designed to match the pin order used on most PC serial interfaces, so that a straight cable can be used to connect the two. Therefore, connect each pin's signal to the same signal name on the PC connector.

For example, pin #2 'RD' should be connected to the 'RD' input terminal on the FP's connector.

Refer to section "2-4 Option Cable Pin Diagrams" for information about each signal's direction.

Specifications

2-3-3 Mouse Connector (MOUSE IN)

Mini DIN 6-pin (Female)

(Common to front and side)

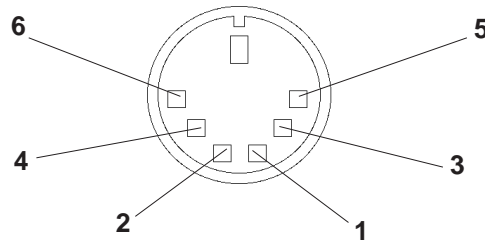

<Manufactured by Hoshi Electronics, Inc.:
TCS7568-43-201 or equivalent>

Pin No.	Signal name
1	MOUSE DATA
2	NC
3	GND
4	+5V (OUT)
5	MOUSE CLK
6	NC



- The mouse connection can be used for all equipment conforming to the PS/2 mouse standards. However, Pro-face cannot guarantee the FP will operate normally for all types of host and mouse combinations. This unit was developed using the Microsoft Mouse®. Microsoft's other mouse products, the "IntelliMouse" and the "3 Button" mouse cannot be used with this unit.
- When connecting the Mouse, be sure to use the Mouse Type Host connector (MOUSE OUT) and the Host PC Mouse/Keyboard cable (FP-CK01)
- Do not connect this cable when the power to the FP and the host (PC) are both ON.
- After connecting the mouse, please re-start the Host unit's OS.
- When Windows 95 or Windows NT is used, set the "Control panel - Mouse - Motion" feature to the standard pointer speed and hide the pointer trace.



2-3-4 Mouse Type Host Connector (MOUSE OUT)

Mini DIN 4-pin (Female)

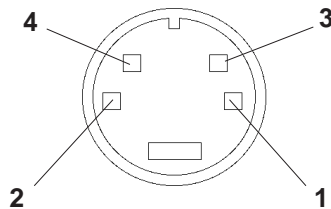

<Connector Maker: JST, JST/MD-S6100 or equivalent>

Pin No.	Signal name
1	GND
2	+ 5V
3	MOUSE CLK
4	DATA



- If the Host PC Mouse/Keyboard cable (FP-CK01) is not used with the Mouse Type Host connector (MOUSE OUT), the mouse cannot be used.
- Do not connect this cable when the power to the FP and the host (PC) are both ON.

2-4 Option Cable Pin Diagrams

RGB Interface Cable Pin (Optional cable: VGA specification) Assignments

FP Connector			RGB cable			PC Connector			
1	Analog R	Input	1	RED IN	RED VIDEO	1	Output	RED VIDEO	1
2	Analog G	Input	2	GRN IN	GRN VIDEO	2	Output	GRN VIDEO	2
3	Analog B	Input	3	BLU IN	BLU VIDEO	3	Output	BLU VIDEO	3
4	Reserved	-	4	NC	NC	4	-	NC	4
5	Digital ground	-	5	GND	GROUND	5	-	GROUND	5
6	Return R	-	6	RED	GROUND RED	6	-	GROUND RED	6
7	Return G	-	7	GRN	GROUND GRN	7	-	GROUND GRN	7
8	Return B	-	8	GND	GROUND BLU	8	-	GROUND BLU	8
9	Reserved	-	8	BLU	NC	9	-	NC	9
10	Digital ground	-	9	GND	GROUND	10	-	GROUND	10
11	Reserved	-	10	NC	MONITOR	11	-	MONITOR	11
12	Reserved	-	11	GND	SENSE(COLOR)	12	-	SENSE(COLOR)	12
13	H.SYNC	Input	12	NC	MONITOR	13	Output	MONITOR	13
14	V.SYNC	Input	13	HSYN	SENSE(MONO)	14	Output	SENSE(MONO)	14
15	Reserved	-	14	VSYN	HSYN	15	-	HSYN	15
FG	FG	-	15	NC	VSYN	-	-	VSYN	-
			FG	FG	NC			NC	
					FG	FG			

Signal names for the FP's RGB interface are designed to match the same pin order as the RGB interface on standard PCs. Since this cable is designed to use the same pin numbers for the FP and the PC, it can be connected in either direction. Since the PC connector's pitch is designated in "inch" units, the interface cable and the FP connector's pitch are also designated in "inch" units (4-40UNC).

Specifications

Pin Connections for the SIO Interface Cable (Optional cable: PC/AT specification)

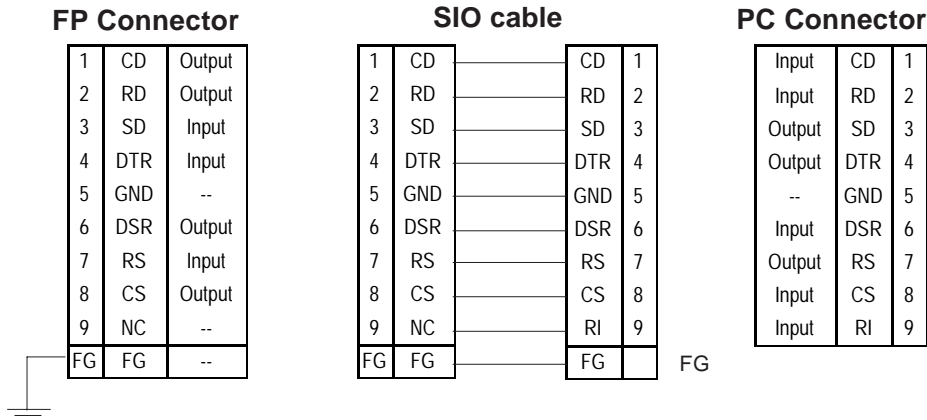

Signal names for the FP's SIO interface are designed to match the same pin order as the SIO interface on standard PCs. As a result, it can be connected in either direction. Since the PC connector's pitch is designated in "inch" units, the interface cable and the FP connector's pitch are also designated in "inch" (4-40UNC) units.

Mouse/Keyboard cable pin numbers

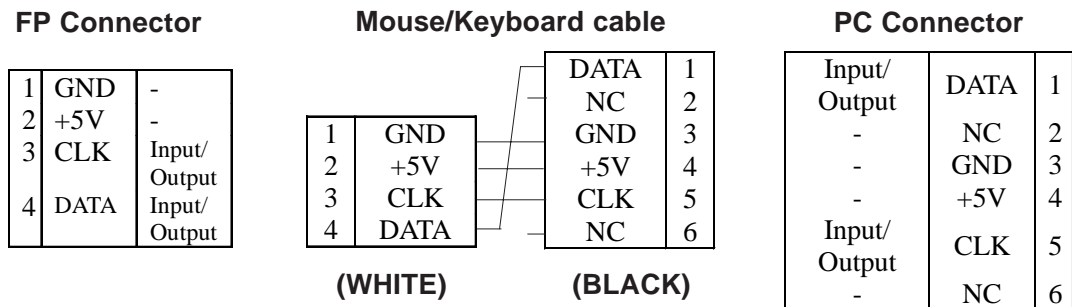

The signal names of the FP unit interface and the mouse/keyboard cable (FP-CK01) conform to those of the personal computer interface. To prevent accidents and connector damage, please be aware that the ends of this connector are different. Connect the 4 pin (white) connector to the FP, and the 6 pin (black) connector to the PC.

2-5 Parts Names and Functions

Front View

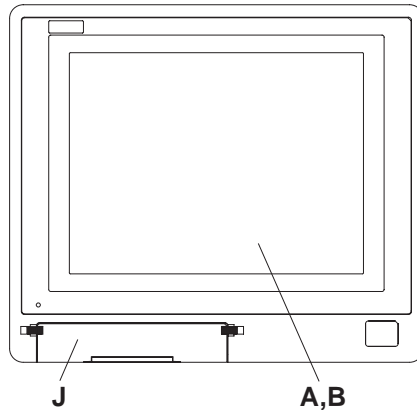

A: TFT type color LCD

The FP units' output display. Data from the host are displayed.

B: Touch panel

Used to switch screens and write data to the host.

C: Power input terminal block

Used to connect the power supply cable.

D: Status LED (Under development)

E: Setup switches (DIP switches)

Used to set the FP's operation mode.

F: MOUSE Connector (MOUSE IN)

Used to connect a mouse.

G: MOUSE Host connector (MOUSE OUT)

Sends mouse output data from the FP. Connects to the Host's PS/2 equivalent Mouse input connector.

H: Serial I/F Connector (RS-232C)

Serial RS-232C interface. This connects a serial cable to the FP, and sends FP touch panel data to the Host, and Host commands to the FP.

I: Analog RGB I/F connector

Analog RGB interface connector

J: Front Maintenance Cover (unused)

Rear View

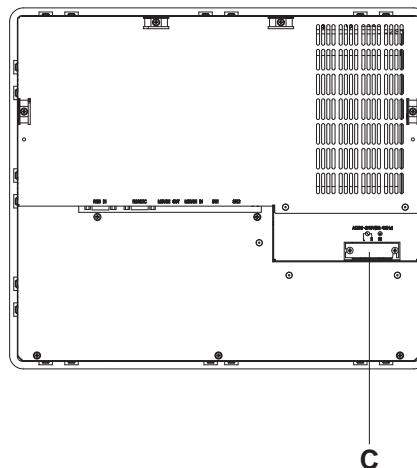

Bottom View

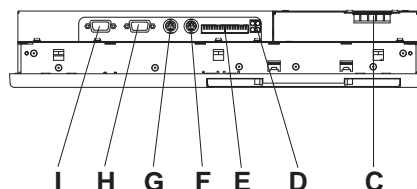

Be sure that all cables are connected correctly and that the FP is turned OFF before any cables are disconnected, since either of these can cause the FP to malfunction.

Specifications

2-6 Dimensions

2-6-1 FP-790T External Dimensions

Unit: mm [in.] (excluding projections)

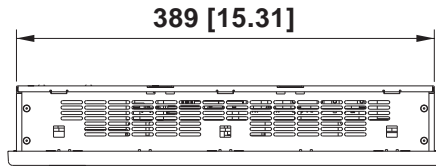

Top View

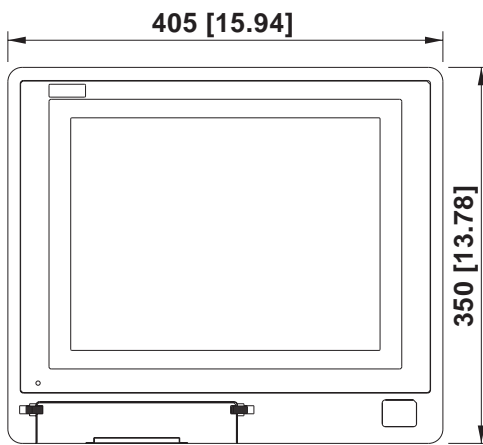

Front View

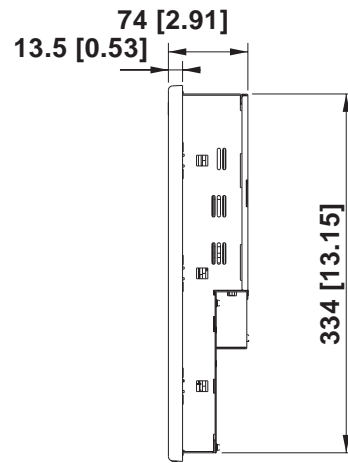

Side View

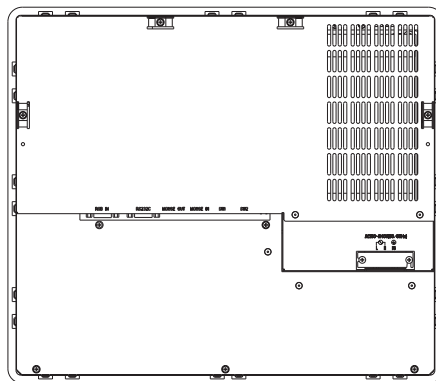

Rear View

2-6-2 Installation Fasteners

Unit: mm [in.] (excluding projections)

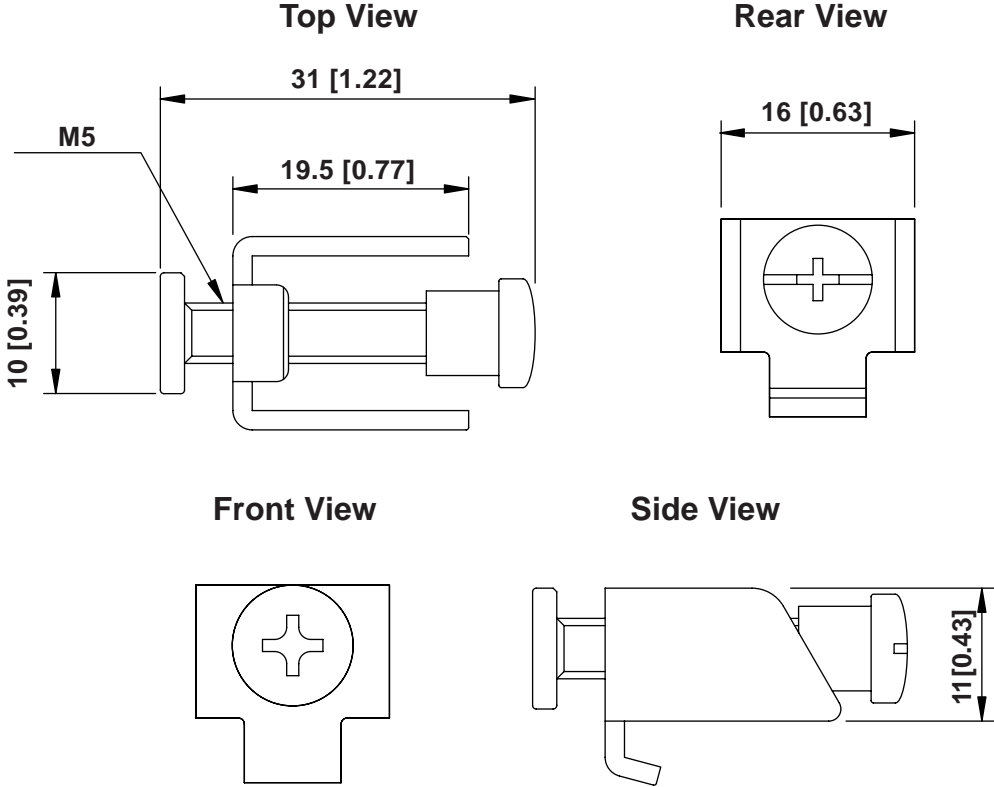

2-6-3 Panel Cut Dimensions

Unit: mm [in.] (excluding projections)

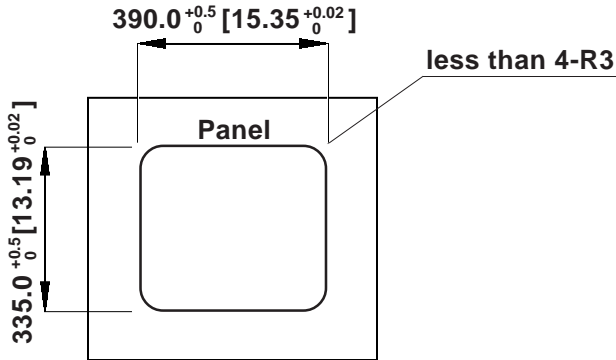

- If the FP's mounting panel is not sufficiently thick or strong, the specified level of moisture-resistance may not be possible.
- If the dimensions of the Panel Cut are larger than those given here, the panel can warp and distort the FP unit's display.

MEMO

Chapter 3

Installation and Wiring

1. Installation
2. Wiring
3. Setup of Operation Mode and Positioning of Display

3-1 Installation

3-1-1 Installation Procedures

Install the FP according to the following procedures.



- **Before mounting the FP into a cabinet or panel, check that the Installation Gasket is attached to the unit.**
- **A gasket which has been used for a long period of time may have scratches or dirt on it, and could have lost much of its dust and drip resistance. Be sure to change the gasket periodically, or when scratches or dirt become visible.**
- **The gasket must be inserted correctly into the groove for the FP's moisture resistance to be equivalent to IP65f.**
- **The upper surface of the gasket should protrude approximately 2mm out from the groove. Be sure to check that the gasket is correctly inserted before installing the FP into a panel.**

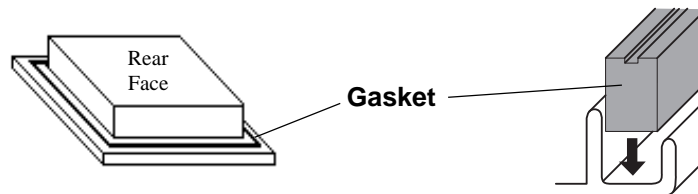

- **The gasket is flexible, but not elastic, and may tear if stretched too far. Do not stretch the gasket around the ribs, only push.**
- **Be sure the gasket's seam is not inserted into any of the unit's corners, only in the straight sections of the groove. Inserting it into a corner may lead to its eventually tearing.**

1. Create a Panel Cut

Using these FP installation dimensions as a guide, create (cut) the correct sized installation opening. The FP's seal, installation brackets and screws are all required when installing the FP. **Reference** 2-6-3 FP Panel Cut Dimensions

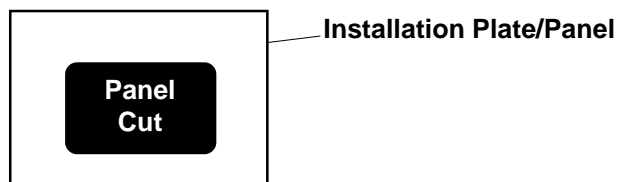

Installation and Wiring



- Note:**
- It is important that the plate/panel surface is flat, clean, and without any jagged edges. If the panel is thin and may warp, attach a reinforcing plate to the panel.
 - The Plate/Panel thickness should be between 1.6 and 10.0mm.

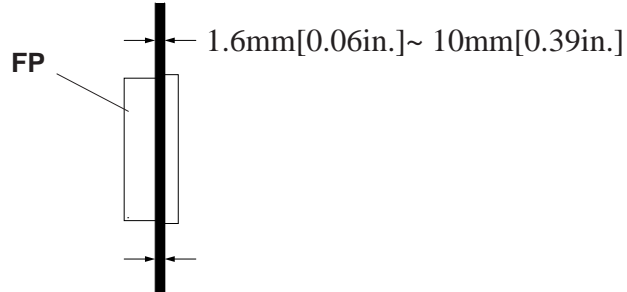

If the plate/panel used is too thin or weak, a satisfactory moisture-resistant seal may not be created.



- Note:**
- For easier maintenance and operation, and improved ventilation, be sure the FP is installed at least 100 mm away from any adjacent structures or objects.

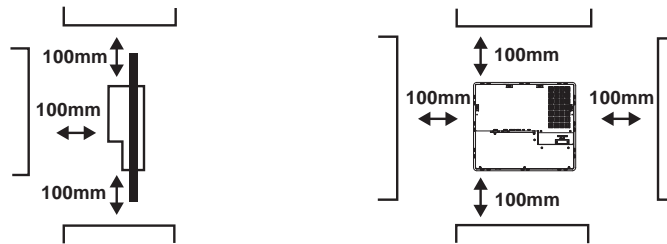

- The FP uses natural ventilation through its outer shell for cooling. When installing the unit horizontally or sideways (portrait style), use a fan or air conditioning unit to prevent overheating.

Horizontal Installation

(Landscape type)

Side View



Front View

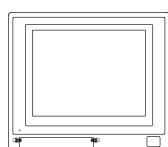

(Flat Type)
(Looking down at)



Vertical Installation

(Portrait Style)

Side View



Front View

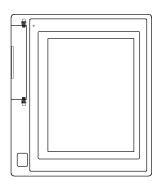

Installation and Wiring

- Check that heat from surrounding equipment will not cause the FP to overheat.
- Be sure this unit is located as far away as possible from electromagnetic circuits, non-fuse type breakers, and other equipment that can cause arcing.
- When installing the FP in a panel with an angled face, the face should not incline either backwards or forwards more than 30°.

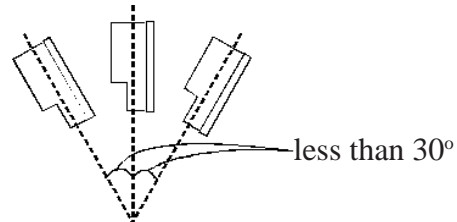

Insert the FP into the panel cut from the front of the panel.

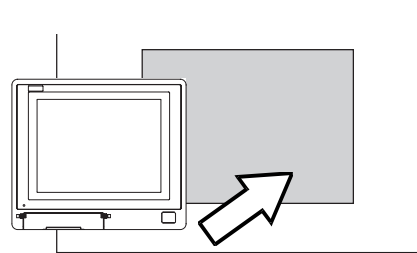

Side view



Panel



Installation and Wiring

2. Secure the FP in place using the installation fasteners.

Insert the installation fasteners hooks into the slots provided on the top, bottom and sides of the FP (three slots on the top and bottom and three slots in the right and left sides, respectively).

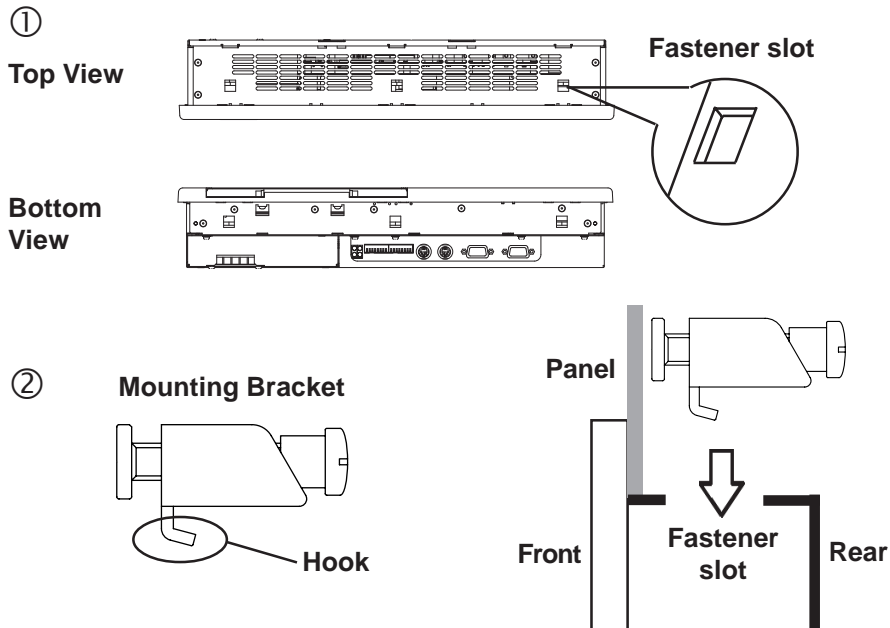

- ③ After inserting the hook into the slot, move the bracket backward. Then, use a screwdriver to tighten the screw and secure the FP in place.

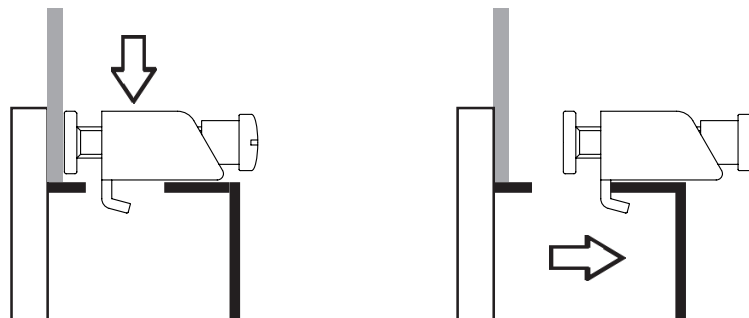

Tighten the installation fastener's screw with a screwdriver. To ensure the FP's front panel is sufficiently moisture-resistant, tighten the screw with no more than 0.5 to 0.6 N-m of torque.

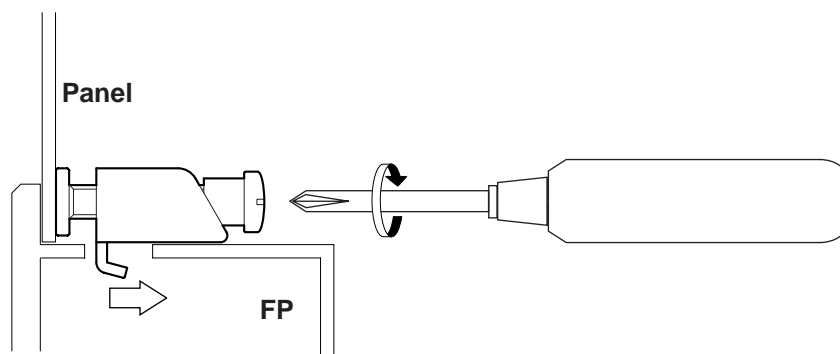

Excessive torque may cause damage to the unit.

3-2 Wiring

This section describes wiring installation precautions and the FP's power cord wiring procedure.

3-2-1 Power Cord Connection Precautions

⚠ WARNINGS

- When connecting the power cord, be sure that power is not supplied to the FP due to the danger of electric shock.
- If a voltage exceeding the FP's specified power range is applied, both the FP and the power supply units will be damaged.
- Since the FP has no power switch, set up a separate circuit breaker.



When the frame ground (FG) terminal is not connected, the FP is easily affected by noise interference. Be sure to ground the unit.



- Use thick wire (2 mm² max.) for the FP's power cable. Be sure that the cable is twisted near the ring terminals.
- Use ring terminals with the following dimensions:



- To prevent the power terminals from being short-circuited due to a loose screw, use ring terminals with insulating sleeves.

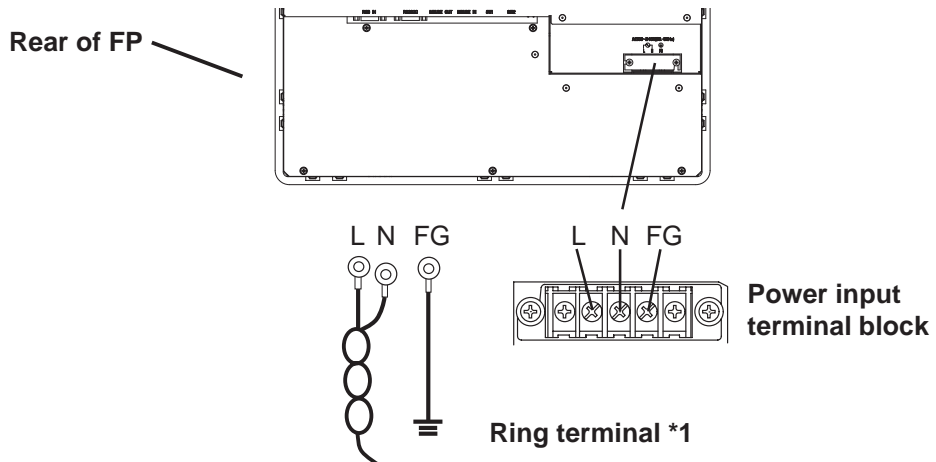

*1 L = Live line for AC input
 N = Neutral line for AC input
 FG = Ground terminal to be connected to the FP housing
 Recommended ring terminal: V2-MS3 or equivalent
 (Manufactured by JST Co.)

Installation and Wiring

3-2-2 FP Power Cord Connection Procedure

- 1) Connect the FP's power cord to the main power supply.
- 2) Check to make sure the FP's power cord is disconnected from the main power supply.
- 3) Remove the terminal block's transparent cover.
- 4) Remove the screws from the 3 middle terminals, align the ring terminals and re-attach the screws. (Check that each wire is securely connected)
- 5) Replace the terminal block's transparent plastic cover.



Note: Use no more than 0.5~0.6N•m of torque to tighten the screws.

3-2-3 FP Power Supply Connection Procedures

Please pay special attention to the following points when connecting the power cable to the FP-790T's Terminal Block.

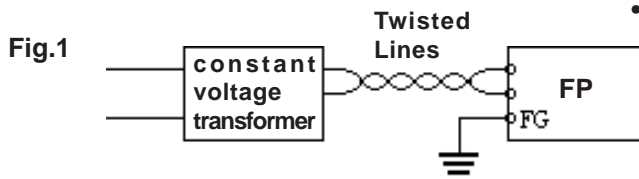

- If the voltage supplied exceeds the FP's designated range, connect a voltage transformer.

Reference Chapter 2, "Specifications", for the allowable voltage range.

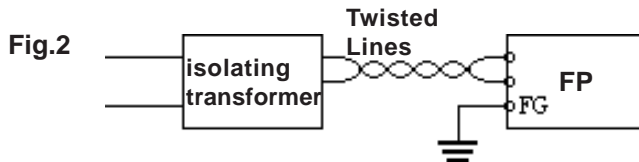

Between the line and ground, select a power supply that is low in noise. If there is an excessive amount of noise, connect a noise reducing transformer.

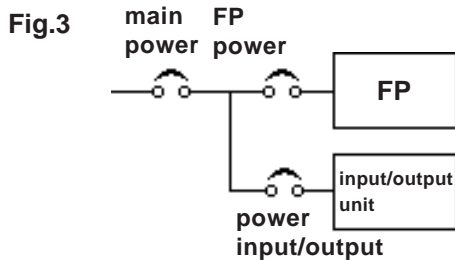

Note: Use Voltage and Noise Reducing transformers with capacities in excess of 100VA.

- When supplying power to the FP, separate the power input/output and operation signal lines as shown in figure 3.

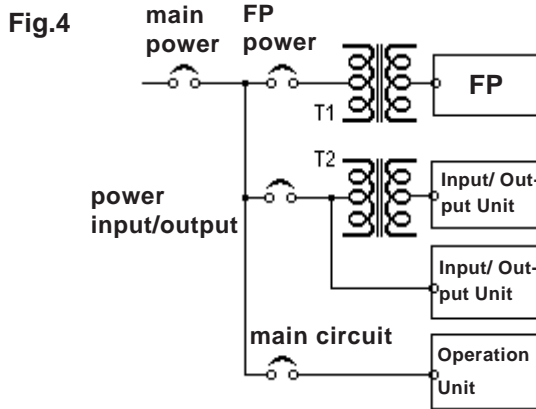

- To increase the FP's noise resistance, twist the power cable before connecting it to the FP.

- The power cord must not be bundled or kept close to the main circuit lines (high voltage, high current), or input/output signal lines.

- Connect a surge absorber, as shown in the diagram, to deal with power surges.

- To prevent noise, make the power cord as short as possible.

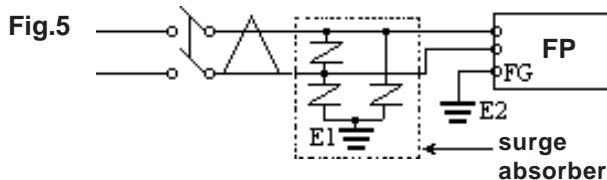

Note: Be sure the surge absorber (E1) is grounded separately from the FP (E2).

- Select a surge absorber that has a maximum circuit voltage greater than the power supply's peak voltage.

Installation and Wiring

3-2-4 FP Grounding Cautions

(a) Exclusive grounding (BEST)

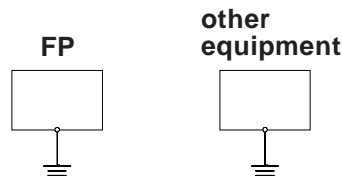

- Connect the FP's FG terminal to an exclusive ground. [Grounding resistance of under 100Ω.]

(b) Common grounding (OK)

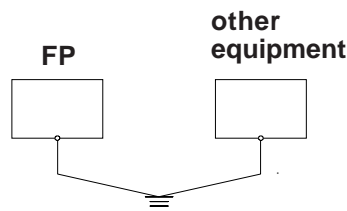

- If exclusive grounding is not possible, use a common grounding point.
- The grounding wire should have a cross section larger than 2mm². Make the connection point as close to the FP as possible, and make the wire as short as possible. When using a long grounding wire, use a thicker wire placed in a duct.

(c) Common grounding (BAD)

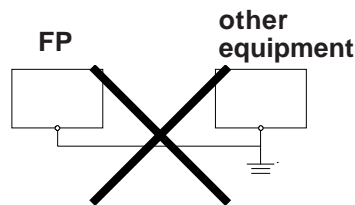

- If the FP does not function properly when grounded this way, disconnect the ground wire from the FP's FG terminal.

3-2-5 FP Input/Output Signal Line Cautions

- Input and output signal lines must be separated from power cables.
- If this is not possible, use a shielded cable and connect the shield to the FP chassis.

3-3 Setup of Operation Mode and Positioning of Display

3-3-1 Operation Mode Setup and Adjustment

The setup switches (dip-switches) are located in the rear of the FP.

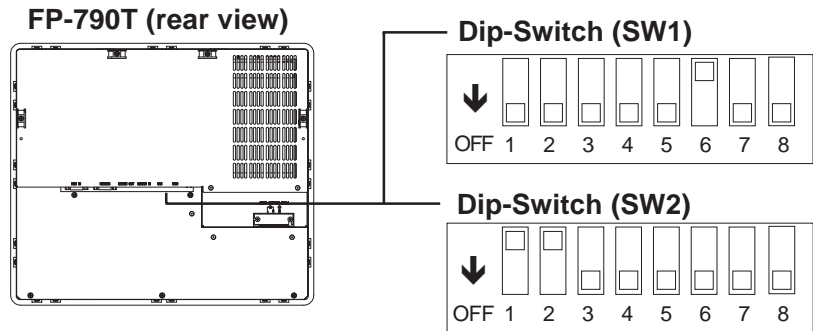

Prior to shipment, the FP's DIP switches have been set as shown above. These 8 bit DIP switches control the items listed below:

Dip Switch 1

No.	Function	OFF	ON
1	Reserved	Set this switch to OFF	
2			
3			
4			
5	Screen Display Setting	Normal Mode	OSD Starting Up
6	Backlight Setting	OFF when stating up	ON when stating up
		Choose to turn backlights ON when starting up, or keep OFF until operating the unit	
7	Reserved	Set this switch to OFF	
8	Automatic Backlight OFF	OFF	ON
		When not operating the unit for a specific period of time (5 min. Default setting), choose whether backlight OFF or not.	

Installation and Wiring

Dip Switch 2

No.	Function	OFF	ON
1	External Mouse Interface	NO	YES
2	Touch Data Transmission Mode Selection	(Reserved)	(RS232C when in use)
3	Touch and click sound	ON	OFF
4	Touch Panel Calibration Setting	Set this switch to OFF	
5	Screen Setting Mode Switch ^{*1}	Normal Mode	Screen Setting Mode (turn OFF when adjusting the screen)
6	Reserved	Set this switch to OFF	
7			
8			

*1 A menu display disappears after about 10 seconds, and when touching SELECT area (screen's lower left corner), the menu display reappears.

3-4 Screen Adjustment using OSD

Use the OSD (On Screen Display) to adjust the following items:

- 1) Brightness
- 2) Contrast
- 3) Horizontal Size Adjustment
- 4) Phase Adjustment
- 5) Horizontal Display Position
- 6) Vertical Display Position
- 7) All Reset (Default)

OSD Start Up by touching a panel (When DIPSW2-5 are OFF.)

Touching the left upper corner, right upper corner, and right lower corner of the touch panel within 5 seconds, will start up the OSD. Touching the left lower corner within 5 seconds, will also start up the OSD.

OSD Start Up by dip switches (When DIPSW2-5 are ON.)

Touching the left lower corner of the touch panel, will start up the OSD.
To exit Adjusting mode, turn DIPSW1-5 OFF.

How to Quit

To quit the OSD automatically, do not touch the touch panel for approximately 5 seconds.



- **The effective range area for each corner is 1/10 the length of the panel.**
- **Since touch panel input data is used for OSD screen adjustment until quitting the OSD, regular input data will not output from the FP.**

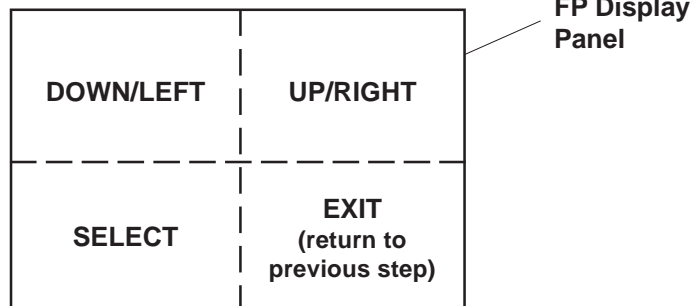

- | | |
|-----------|--|
| DOWN/LEFT | Used to increase /decrease the value of each setting item, or used to move downward when selecting an item in Menu mode. |
| UP/RIGHT | Used to increase /decrease the value of each setting item, or used to move upward when selecting an item in Menu mode. |
| SELECT | Used to select each setting item in the OSD menu. |
| EXIT | When EXIT is pressed, the changed value is saved, and the previous menu is displayed. |

Installation and Wiring

Adjustment Menu

This area displays the FP's adjustment menu. Every time you press this switch, the On Screen Display toggles between ON and OFF, and when one of adjustment items is selected and the switch is pressed, an adjustment screen will be called up.

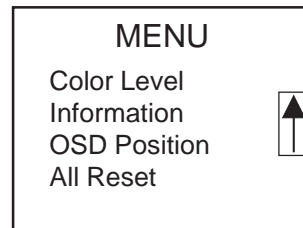
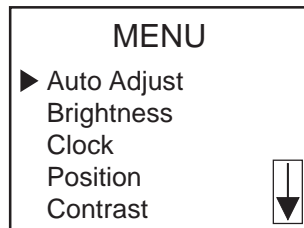

Auto Adjust	Adjust all the adjustment items.
Brightness	Adjust the brightness.
Clock	Adjust the dot clock frequency.
Position	Adjust the horizontal and vertical positions.
Contrast	Adjust the contrast
Color Level	Adjust RGB colors and white balance.
Information	Displays the current screen settings.
OSD Position	Used to adjust OSD display position.
All Reset	Reset all the setting data.

To perform display adjustments, follow the procedures given below:

- 1) Turn OSD (Main Menu) ON.
- 2) Use the [DOWN/LEFT] or [UP/RIGHT] switches to choose one of the adjustment items.
- 3) Press the [SELECT] switch to select a desired item, and that item's adjustment screen will be called up.
- 4) Use the [DOWN/LEFT] or [UP/RIGHT] switches to change the value of the selected item.
- 5) Press the [EXIT] switch to return to the OSD menu. (Control will return to the OSD menu after 5 seconds when no panel operation is performed.)

Chapter 4

Touch Panel Commands

1. Command List
2. Touch Panel Data Input
3. Boot-up Initialization

4-1 Command List

This section describes the serial commands available with the FP (command transmission from the host (PC) to the touch panel (FP)).

<Serial Command List>

Code	Function
65h	Turns on the backlight.
67h	Turns off the backlight. (Automatic reset)
69h	Turns on the click sound.
6Ah	Turns off the click sound.
71h	Turns on the buzzer.
72h	Turns off the buzzer.
73h	Turns on calibration mode.
74h	Turns off calibration mode.
75h	Turns on touch panel data output.
76h	Turns off touch panel data output.



- **All codes other than those shown here are reserved. These commands should never be issued when using the FP.**
- **The above commands cannot be used with the FP-ME000 Touch Panel Driver (Mouse Emulator) or the English version of the U-TP (Gunze Corporation) software. For details, contact your local Pro-face representative.**



Note: All data and command codes are expressed in hexadecimal numbers. (Example: 65h = 65HEX)

Touch Panel Commands

Backlight ON (High brightness) 65h

Turns on the backlight at high brightness.

Backlight OFF (Automatic reset) 67h

Turns off the backlight. When either SIO communication or touch operation is performed, the backlight is turned on.

Backlight OFF (Command reset) 68h

Turns off the backlight. After a different serial command (e.g. 65h, 66h) is received, the backlight is turned on.

Click sound ON 69h

Every time you touch the display panel a click will sound.

Click sound OFF 6Ah

Turns off the click sound.

Buzzer ON 71h

Turns on the buzzer output

Buzzer OFF 72h

Turns off the buzzer output.



Note: Priority is given to buzzer output over the click sound. Thus, when both the buzzer output and click sound are set to ON, the buzzer output is activated.

Buzzer	Click	Status
ON	ON	Buzzer ON
ON	OFF	Buzzer ON
OFF	ON	Click sound ON
OFF	OFF	Buzzer and click sound OFF

Calibration mode ON 73h

Starts touch panel calibration mode. (Same function as when SW1-5 is ON.)

Calibration mode OFF 74h

Ends touch panel calibration mode. (Same function as when SW1-5 is OFF.)

Touch data ON 75h

Enables touch panel data output.

Touch data OFF 76h

Disables touch panel data output.

4-2 Touch Panel Data Input

The following describes how to connect an RS-232C cable and send FP touch panel data to the host.

RS-232C connection (When SW1-1 is OFF)

Coordinate output data sent from the FP to the host is not exactly equal to the coordinates used on the display device. Therefore, an I/F program is necessary to convert the coordinates on the touch panel into those used on the display device. It is also necessary to calibrate individual panel differences, depending on the touch panel used.

The mouse emulation software listed below can automatically convert the coordinates with simple initial settings.

OS	I/F program		Calibration	Application
Windows [®] 95 Windows [®] 98	Using Japanese OS	FP-790 Mouse Emulator for Windows FP-ME000 (made by Digital Corp.)	Performed by internal program.	FIX-32 (PC data management software package) (Intellution Corp.), or similar application.
Windows NT [®] Windows [®] 2000	Using English OS	English version of U-TP Touch Panel Driver(Gunze Corp.)		

A separate conversion program is required when using a different OS. To create a conversion program for a different OS, please observe the following instructions:

(1) Resolution

The FP has “1024” resolution in both the X and Y axes. The origin point (0,0) is in the upper right corner.

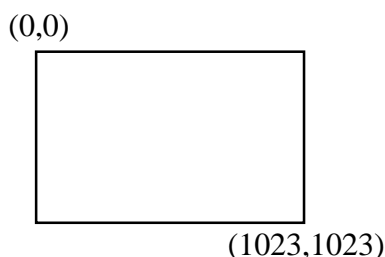

Touch Panel Commands

(2) Data Format

All data is in 8-bit ASCII format, and is structured in the following 11 byte strings.

Header: 1 byte (T = touched; R = released)
 X coordinate: 4 bytes (0000 ~ 1023)
 Separator: 1 byte (,)
 Y coordinate: 4 bytes (0000 ~ 1023)
 Termination code: 1 byte (CR = 0Dh)

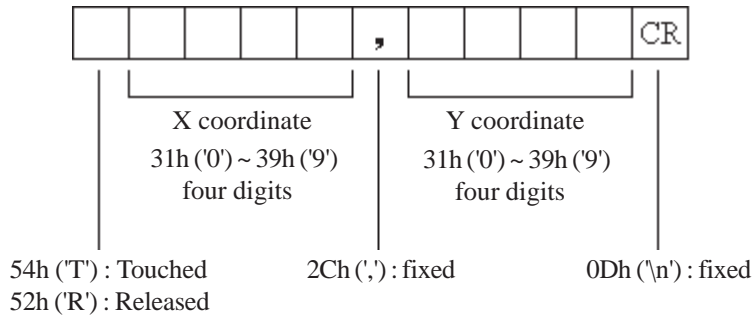

<Example> If the coordinate (X=23, Y=500) is touched.

- T0023, 0500CR — touched
 - T0023, 0500CR — continuous output at the same location
 - T0024, 0500CR — moving the finger without releasing touch
 - T0024, 0499CR
 - ⋮
 - ⋮
 - T0022, 0501CR
 - T0023, 0500CR
 - R0023, 0500CR — when released, only 1 unit of data is sent
- } continuous data output unless finger is released

(3) Sampling Rate

A maximum of 87 points per second.



The PL's touch panel provides a resolution of "1024" (10 bit). However, the resolution of the actual output data is only 20 to 990 (approx.). Therefore, all the coordinates of the pixels on the horizontal axis cannot be detected. According to this calculation, the FP's output data includes coordinates that cannot be displayed, since the touch panel is larger than the display device.

(4) Cable Connection

Connect the RS-232C connector provided at the rear of the FP to the host's serial interface through the optional SIO cable.

▼ **Reference** ▲ Chapter 1 Introduction

Connect the host (PLC) data cable to the FP's rear-mounted RS-232C connector. (Digital's optional SIO cable is recommended)

4-3 **Boot-up Initialization**

When the power is turned ON, the touch panel is initialized as follows.

- Clears its internal buffer.
- Initializes the serial communication mode.

Baud rate	9600bps
Data length	8 bits
Parity	None
Stop bit	1 bit

- Initializes the system default values.

Function	Default setting
Backlight	ON
Backlight condition	ON
Click sound	ON
Buzzer	OFF
Touch panel data output	ON

MEMO

Chapter 5

Troubleshooting

1. Troubleshooting

5-1 Troubleshooting

5-1-1 Possible Device Problems

Two possible types of trouble are as follows.

- **No display**
 - No display appears after the unit is switched on.
 - The screen disappears during RUN mode.
 - The screen display is not normal.

- **Touch panel doesn't respond**

The touch panel does not react when pressed, or its reaction time is abnormally slow.

Troubleshooting procedures for these problems are described in the flowcharts on the following pages.



WARNINGS

- **Because of the danger of an electric shock, be sure the power cord is not connected when wiring the unit.**
- **When changing the backlight, since there is a danger of an electric shock or burn, be sure to turn the FP off and wear gloves.**



This section assumes that the FP is the cause of a problem, not the host (PLC). When the host is the problem, please refer to that device's manual.

Troubleshooting

5-1-2 No Display

When the screen does not display when powering up, or if the screen turns OFF by itself, use the flowchart below to find an appropriate solution.

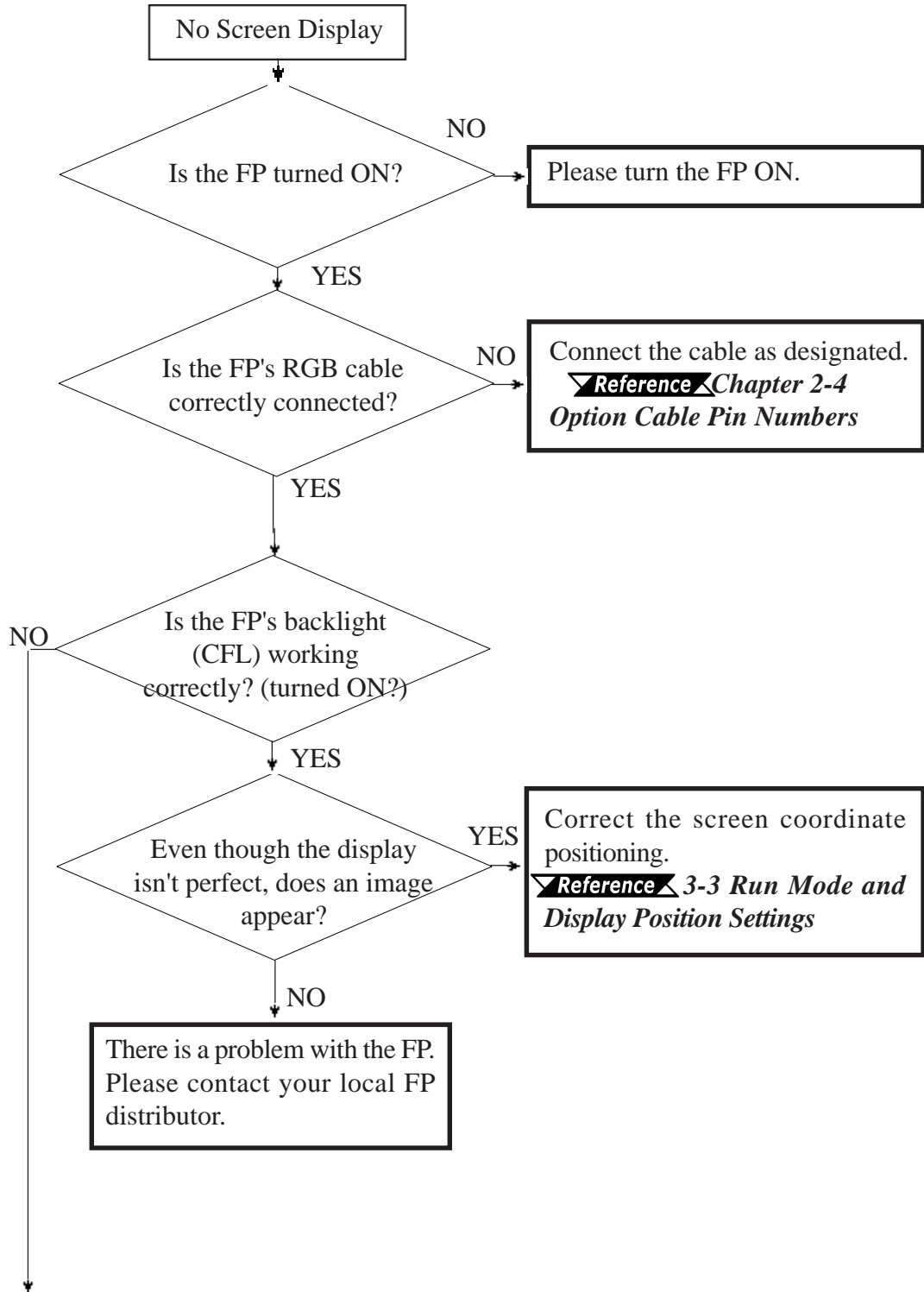

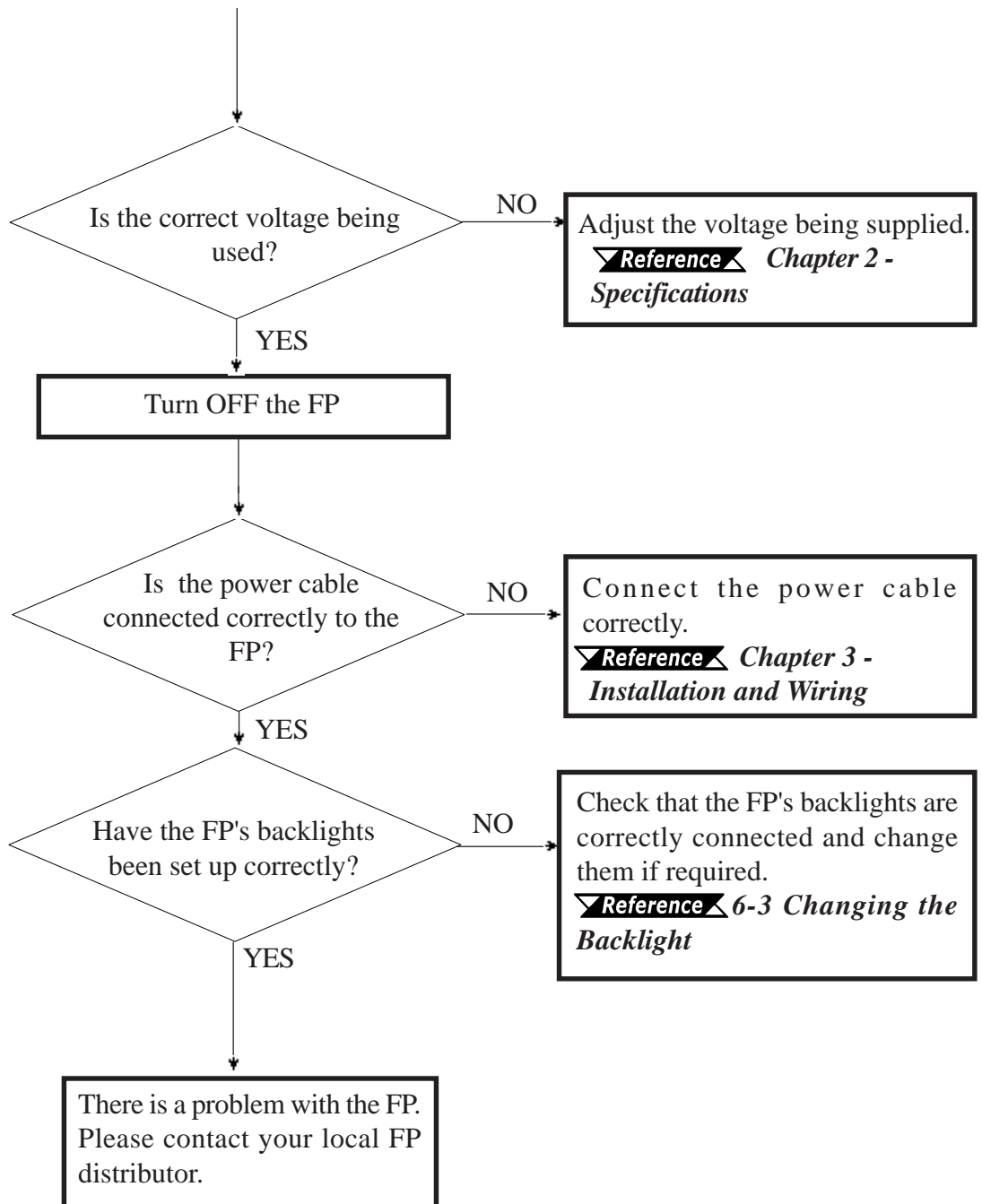

Troubleshooting

5-1-3 The Touch Panel Does Not Respond

When the touch panel does not react to your touch, use the flowchart below to find the origin of the problem and the appropriate solution.



- To use the SIO connection mode, a touch panel communication program is required.
- To use the mouse connection mode, it is necessary to set up the PS/2 mouse driver included in your OS.

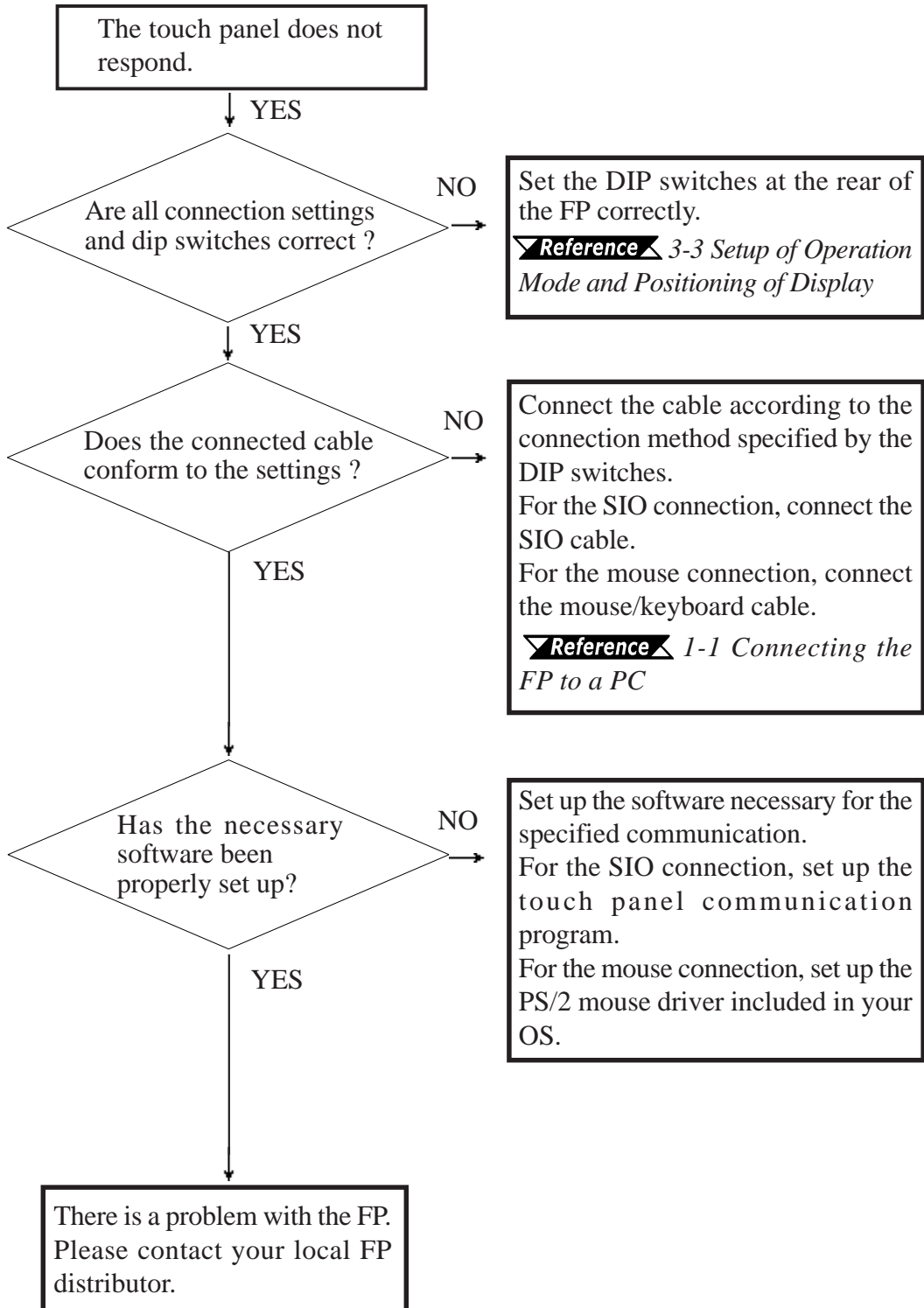

Chapter 6

Maintenance

1. Cleaning the FP's Display
2. Periodic Check-up
3. Changing the Backlight

This chapter describes the precautions and inspection procedures necessary to ensure satisfactory FP performance.

6-1 Cleaning the FP's Display



Neutral detergent

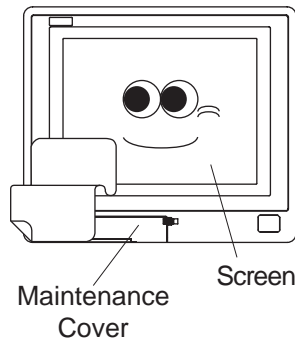

When the FP's display or case becomes dirty, use a neutral detergent applied to a damp soft cloth to clean the surface.



Paint thinner
Organic solvent
Acidic agents

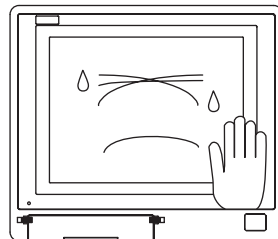

Do not use paint thinner, organic solvents, or highly-acidic agents to clean the unit.

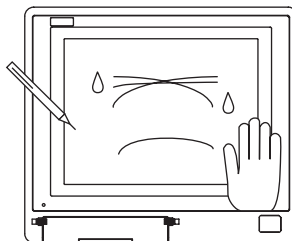

Do not press the touch panel display with sharp objects, such as a mechanical pencil; otherwise, the display may be damaged.

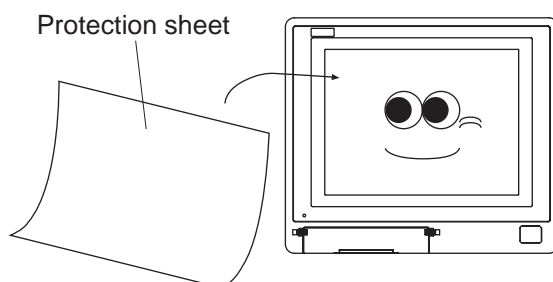

Attach the protection sheet when using the FP in a harsh environment.

To maintain your FP in its best condition, please check the unit periodically.

Inspection Items:

(When the FP is mounted into a cabinet, the conditions inside the cabinet are considered to be the environment)

Surrounding Environment

- Is the surrounding temperature within the allowable range? (0°C~40°C)
- Is the humidity within the specified range? (30% RH~85% RH)
- Is the atmosphere free of corrosive gas?

Electrical Specifications

- Is the input voltage appropriate? (AC85V TO AC265V)
- Is the power supply voltage stable ?
- Is the power supply frequency correct (50/60 Hz) ?

Attachments

- Is the cable connected properly? Is it loose?
- Are the mounting brackets holding the unit securely?
- Are there many scratches, cuts or traces of dirt on the installation gasket?

6-3 Changing the Backlight



Warning

- Be sure the FP's power cord has been disconnected prior to changing the backlight. When the FP's power cord is connected and the FP is ON, high voltage runs through the wires in the backlight area. Do not touch them!
- When the FP's power cord has just been disconnected, the backlight area is still very hot! Be sure to wear gloves to prevent being burned.
- The backlight is very fragile. Do not touch the glass tube directly or try to remove its power cord. If the glass tube breaks you may be injured.



Important

- *During replacement, be sure to protect the front surface of the FP's display so that it is not scratched or damaged.*
- *The FP has both an upper and a lower backlight bulb. Be sure to replace both at the same time.*
- *Since CFL is used for the backlights, they should be disposed of in a manner appropriate to your local government's laws or regulations.*

Replace the backlight according to the procedure below. (The following explanation assumes that the FP has already been removed from the panel)

- 1) Place the FP on a flat worktable with the front panel facing down.
- 2) Loosen the nine (9) rear cover attachment screws, and remove the rear cover.

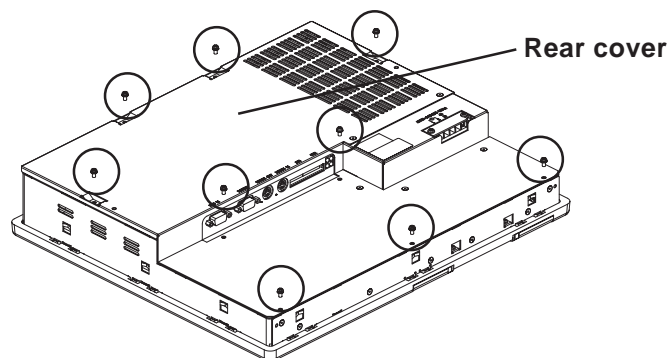

- 3) Remove the three (3) inner unit attachment screws.

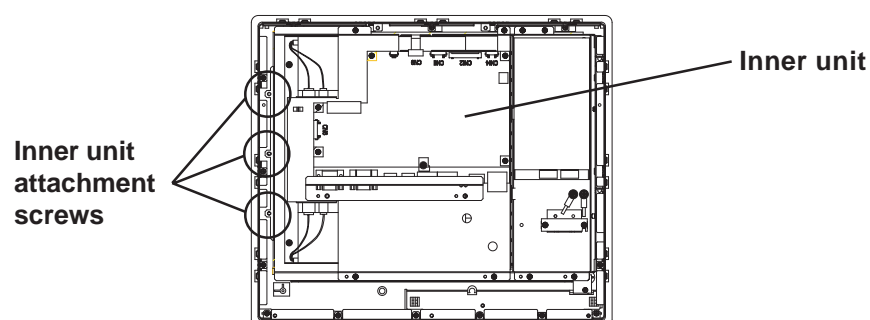

Maintenance

- 4) Free the backlight power cables from the cable clamps, and detach the four (4) backlight power connectors that connect the backlights to the inverter.

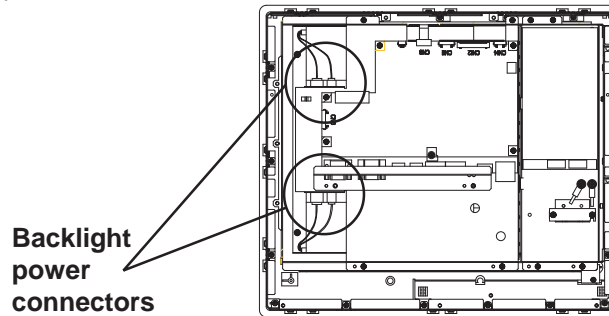

- 5) Lift up and hold one side of the inner unit (left or right).

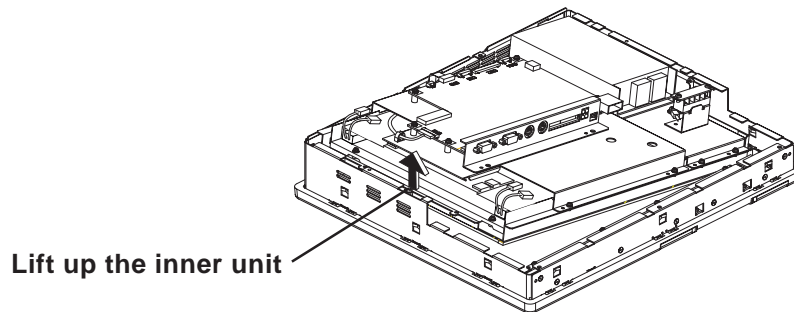

- 6) Carefully bend each backlight's Positioning Tab upwards until it is clear of the Positioning Pin. Then, slowly pull out each backlight horizontally from its holder.

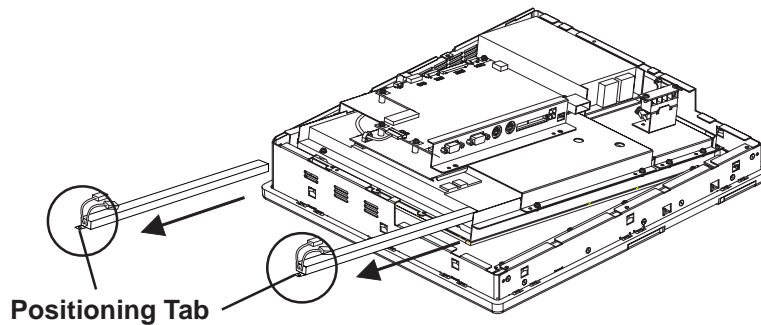

- **Be sure to pull out the backlights gently if they become stuck in their holders, or they can be damaged.**
- **When pulling out the backlight and holding the Positioning Tab, be sure not to cut or pinch your fingers.**

◆ Attach Replacement Backlight

- 1) Insert each replacement backlight completely into its holder, until the Positioning Tab's hole is over the Positioning Pin.

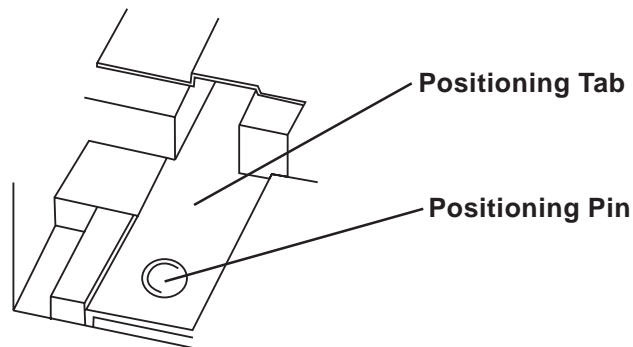

- 2) Secure each backlight cable in place by inserting it into its Cable Clamp.

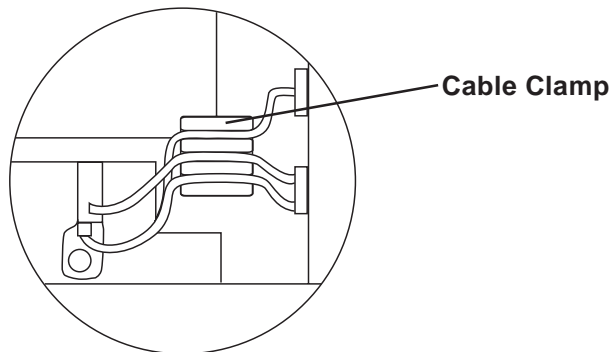

- 3) Connect all four (4) backlight power connectors.
- 4) Replace all three (3) inner unit attachment screws to secure the inner unit in place.
- 5) Reattach the rear cover, and replace the nine (9) rear cover attachment screws.



- **Be sure not to pinch or cut any of the FP unit's internal wiring when closing the rear cover.**
- **If any of the attachment screws becomes misplaced, check to be sure that they have not fallen inside the FP. If a screw has fallen inside the FP, do not connect the FP unit's power cord until the screw has been removed.**

After changing the backlight, be sure to check that your FP display operates correctly. If a problem occurs, contact your local FP distributor.

MEMO

Index

A

Analog RGB Interface (RGB IN) 2-3

B

Boot-up Initialization 4-5

C

CE Marking Notes vii

Changing the Backlight 7-3

Cleaning the FP's Display 7-1

Connecting the FP to a PC 1-1

E

Electrical Specifications 2-1

Environmental Specifications 2-2

Essential Safety Precautions ii

External Dimensions 2-9

F

FP Grounding Cautions 3-7

FP Input/Output Signal Line Cautions 3-7

FP Power Cable Connection Procedure 3-5

FP Power Supply Connection Procedures 3-6

FP-790T Features viii

Functional Specifications 2-2

H

Host Interface for Mouse (MOUSE OUT) 2-5

I

Installation Fasteners 2-10

Installation Procedures 3-1

M

Mouse Interface (MOUSE IN) 2-5

Mouse/Keyboard cable pin numbers 2-7

O

Optional Equipment 1-3

Optional Maintenance Parts 1-2

Optional Parts 1-2

P

Package Contents ix

Panel Cut Dimensions 2-10

Parts Names and Functions 2-8

PC Connection Notes vii

Periodic Check-Up 7-2

Pin Assignments and

 Signal Names for Serial Interf 2-4

Pin Connections for the SIO Interface Cable 2-7

Power Cable Connection Precautions 3-4

R

RGB Interface Cable Pin Assignments 2-6

S

Screen Adjustment using OSD 3-10

Serial Command List 4-1

Serial Interface (RS232C) 2-4

Setup of Operation Mode

 and Positioning of Display 3-8

Structural Specifications 2-1

Symbol Information x

T

Touch Panel Data Input 4-3

Touch Panel Specifications 2-2

Troubleshooting 6-1

MEMO